

Raytheon

**High Performance
Quad Operational Amplifier**

RC4156

Features

- Unity gain bandwidth —
3.5MHz typical; 2.8MHz guaranteed
- High slew rate —
1.6V/μS typical; 1.3V/μS guaranteed
- Low noise voltage —
1.4μV typical; 2.0μVRMS guaranteed
- Indefinite short circuit protection
- No crossover distortion
- Low input offset and bias parameters
- Internal compensation

Description

The 4156 is a monolithic integrated circuit, consisting of four independent high performance operational amplifiers constructed with an advanced epitaxial process.

These amplifiers feature guaranteed AC performance which far exceeds that of the 741 type amplifiers. Also featured are excellent input characteristics and guaranteed low noise, making this device the optimum choice for audio, active filter and instrumentation applications.

Mask Pattern

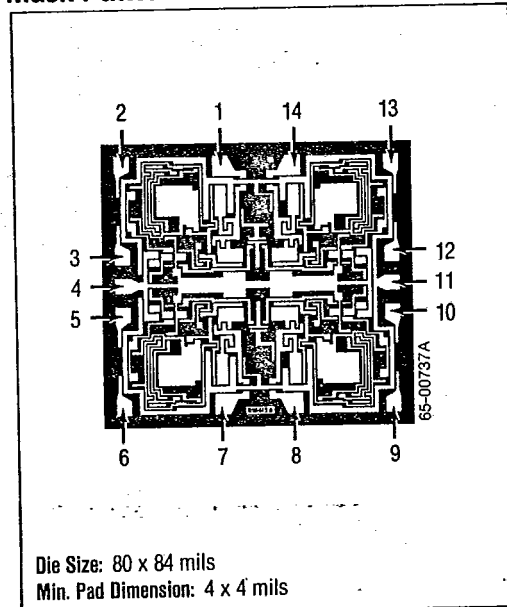

Schematic Diagram (1/4 Shown)

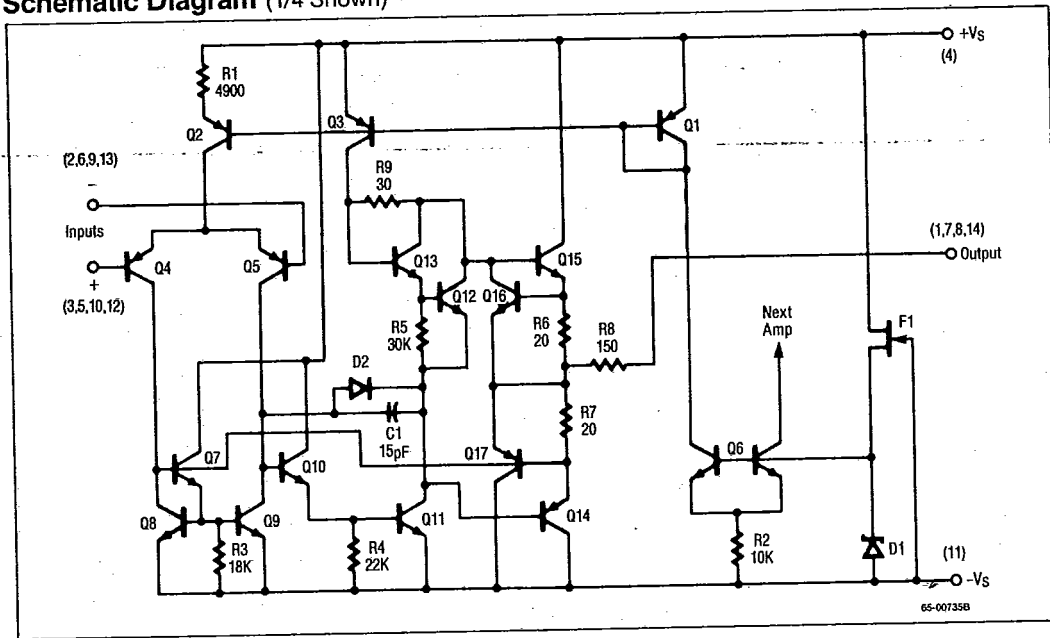

Connection Information

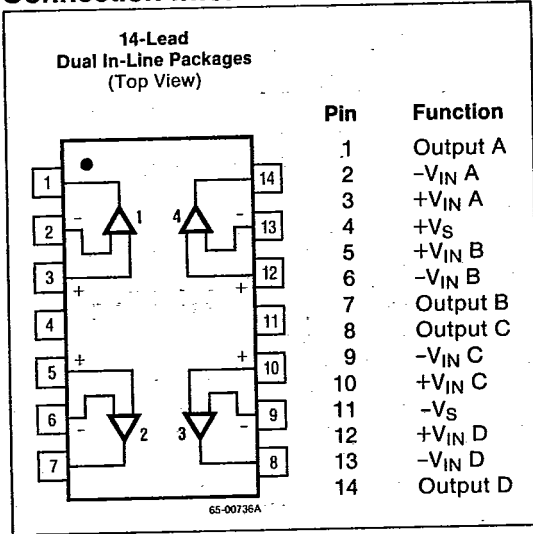

Thermal Characteristics

	14-Lead Plastic DIP	14-Lead Ceramic DIP
Max. Junction Temp.	125°C	175°C
Max. P _D T _A < 50°C	468mW	1042mW
Therm. Res. θ _{JC}	—	50°C/W
Therm. Res. θ _{JA}	160°C/W	120°C/W
For T _A > 50°C Derate at	6.25mW per °C	8.33mW per °C

Absolute Maximum Ratings

Supply Voltage	±20V
Differential Input Voltage	15V
Input Voltage ¹	±15V
Output Short Circuit Duration ²	Indefinite
Storage Temperature Range	-65°C to +150°C
Operating Temperature Range	
RM4156	-55°C to +125°C
RV4156	-40°C to +85°C
RC4156	0°C to +70°C
Lead Soldering Temperature (60 Sec)	+300°C

- Notes: 1. For supply voltages less than ±15V, the absolute maximum input voltage is equal to the supply voltage.
 2. Short circuit to ground on one amplifier only.

Ordering Information

Part Number	Package	Operating Temperature Range
RC4156DB	Plastic	0°C to +70°C
RC4156DC	Ceramic	0°C to +70°C
RM4156DC	Ceramic	-55°C to +125°C
RM4156DC/883C*	Ceramic	-55°C to +125°C

*MIL-STD-883, Level C Processing

The information contained in this data sheet has been carefully compiled; however, it shall not by implication or otherwise become part of the terms and conditions of any subsequent sale. Raytheon's liability shall be determined solely by its standard terms and conditions of sale. No representation as to application or use or that the circuits are either licensed or free from patent infringement is intended or implied. Raytheon reserves the right to change the circuitry and other data at any time without notice and assumes no liability for inadvertent errors.

Electrical Characteristics ($V_S = \pm 15V$ and $T_A = +25^\circ C$ unless otherwise specified)

Parameters	Test Conditions	RM4156			RC/RV4156			Units	
		Min	Typ	Max	Min	Typ	Max		
Input Offset Voltage	$R_S \leq 10k\Omega$		0.5	3.0		1.0	5.0	mV	
Input Offset Current			15	30		30	50	nA	
Input Bias Current			60	200		60	300	nA	
Input Resistance			0.5			0.5		M Ω	
Large Signal Voltage Gain	$R_L \geq 2k\Omega$, $V_{OUT} \pm 10V$	50	100		25	100		V/mV	
Output Voltage Swing	$R_L \geq 10k\Omega$	± 12	± 14		± 12	± 14		V	
	$R_L \geq 2k\Omega$	± 10	± 13		± 10	± 13		V	
Input Voltage Range		± 12	± 14		± 12	± 14		V	
Output Resistance			230			230		Ω	
Short Circuit Current			25			25		mA	
Common Mode Rejection Ratio	$R_S \leq 10k\Omega$	80			80			dB	
Power Supply Rejection Ratio	$R_S \leq 10k\Omega$	80			80			dB	
Supply Current (All Amplifiers)	$R_L = \infty$		4.5	5.0		5.0	7.0	mA	
Transient Response			50			75		nS	
			Rise Time	25			25		%
			Overshoot						
Slew Rate		1.3	1.6		1.3	1.6		V/ μ S	
Unity Gain Bandwidth		2.8	3.5		2.8	3.5		MHz	
Phase Margin	$R_L = 2k\Omega$, $C_L = 50pF$		50			50		Deg.	
Power Bandwidth	$V_O = 20V_{p-p}$	20	25		20	25		kHz	
Input Noise Voltage	$f = 20Hz$ to $20kHz$		1.4	2.0		1.4	2.0	μ V _{RMS}	
Input Noise Current	$f = 20Hz$ to $20kHz$		15			15		pA _{RMS}	
Channel Separation			108			108		dB	

Electrical Characteristics (Continued)

($-55^{\circ}\text{C} \leq T_A \leq +125^{\circ}\text{C}$ for RM4156, $-40^{\circ}\text{C} \leq T_A \leq +85^{\circ}\text{C}$ for RV4156, $0^{\circ}\text{C} \leq T_A \leq +70^{\circ}\text{C}$ for RC4156, $V_S = \pm 15\text{V}$)

Parameters	Test Conditions	RM4156			RC/RV4156			Units
		Min	Typ	Max	Min	Typ	Max	
Input Offset Voltage	$R_S \leq 10\text{k}\Omega$			5.0			6.5	mV
Input Offset Current				75			100	nA
Input Bias Current				320			400	nA
Large Signal Voltage Gain	$R_L \geq 2\text{k}\Omega$, $V_{OUT} \pm 10\text{V}$	25			15			V/mV
Output Voltage Swing	$R_L \geq 2\text{k}\Omega$	± 10			± 10			V
Supply Current			10			10		mA
Average Input Offset Voltage Drift			5.0			5.0		$\mu\text{V}/^{\circ}\text{C}$

Typical Performance Characteristics

Open Loop Frequency Response

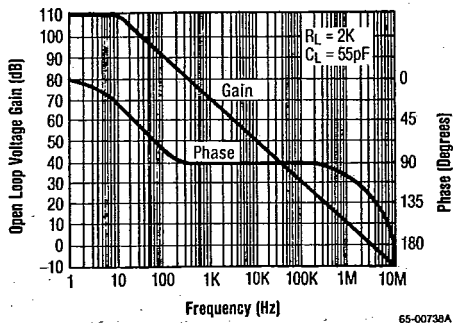

Power Supply Rejection Ratio vs. Temperature

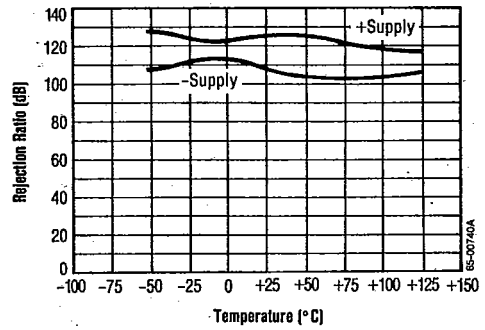

Channel Separation vs. Frequency

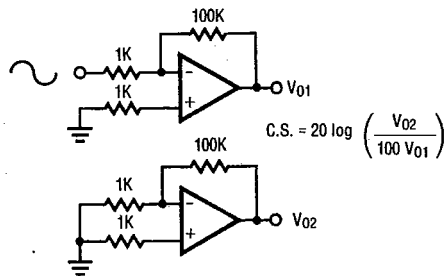
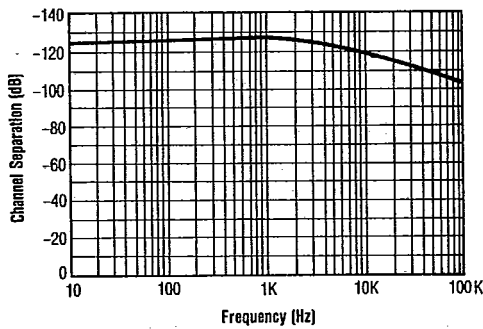

Transient Response vs. Temperature

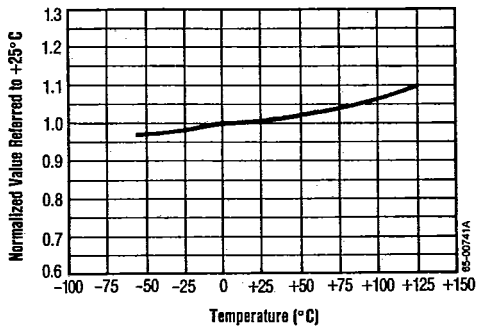

Input Noise vs. Frequency

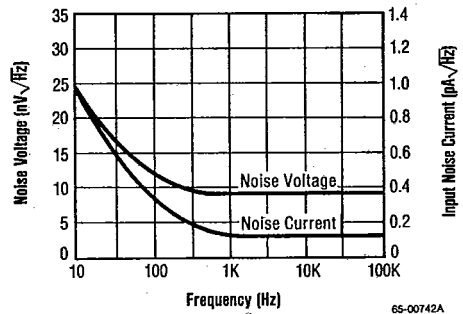

Typical Performance Characteristics (Continued)

Normalized AC Parameters vs. Temperature

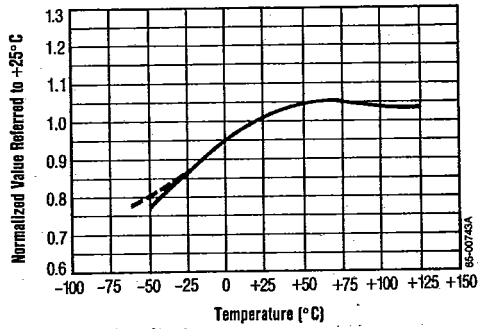

Slew Rate vs. Supply Voltage

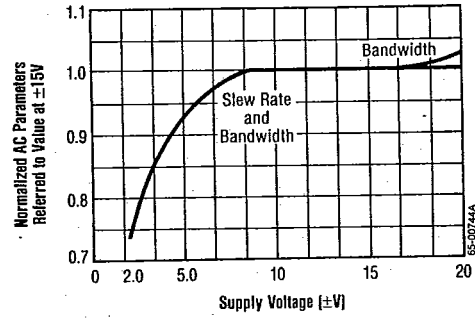

Output Voltage Swing vs. Frequency

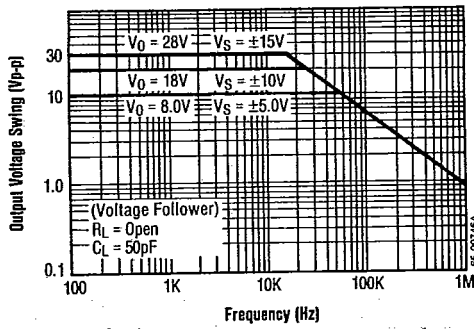

Output Voltage Swing vs. Load Resistance

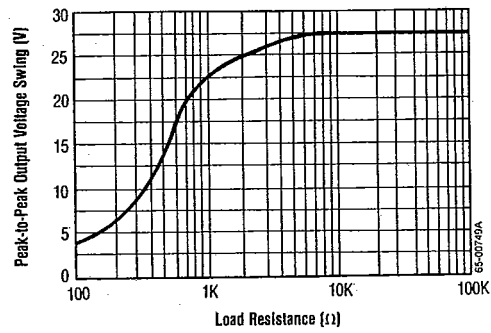

Small Signal Bandwidth and Phase Margin vs. Load Capacitance

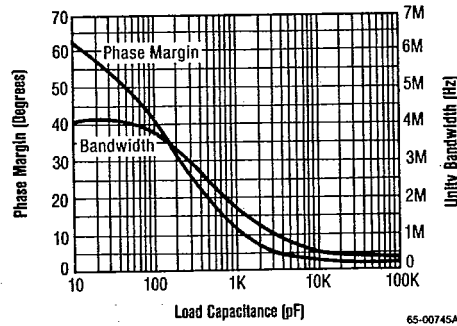

Typical Performance Characteristics (Continued)

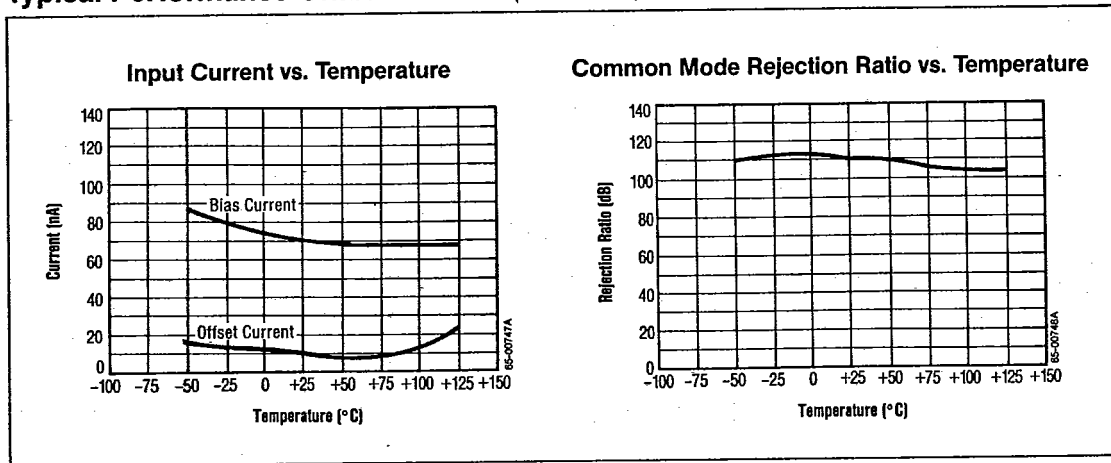

Applications

The 4156 quad operational amplifier can be used in almost any 741 application and will provide superior performance. The higher unity gain bandwidth and slew rate make it ideal for applications requiring good frequency response, such as active filter circuits, oscillators and audio amplifiers.

The following applications have been selected to illustrate the advantages of using the Raytheon 4156 quad operational amplifier.

Triangle and Square Wave Generator

The circuit of Figure 1 uses a positive feedback loop closed around a combined comparator

and integrator. When power is applied the output of the comparator will switch to one of two states, to the maximum positive or maximum negative voltage. This applies a peak input signal to the integrator, and the integrator output will ramp either down or up, opposite of the input signal. When the integrator output (which is connected to the comparator input) reaches a threshold set by R1 and R2, the comparator will switch to the opposite polarity. This cycle will repeat endlessly, the integrator charging positive then negative, and the comparator switching in a square wave fashion.

Amplitude of V_2 is adjusted by varying R1. For best operation, it is recommended that R1 and

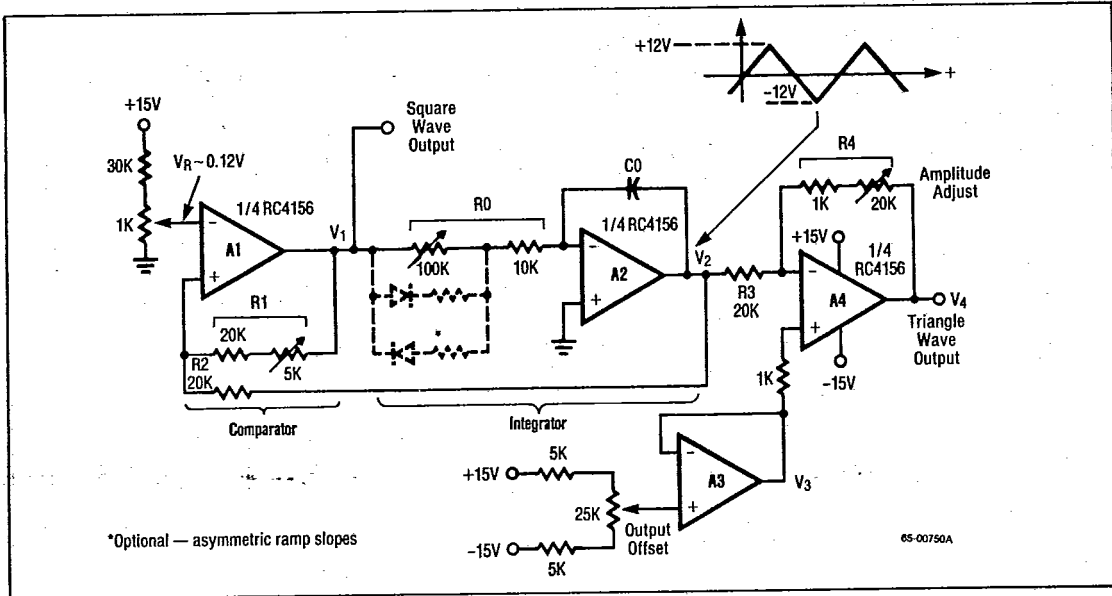

Figure 1. Triangle and Square Wave Generator

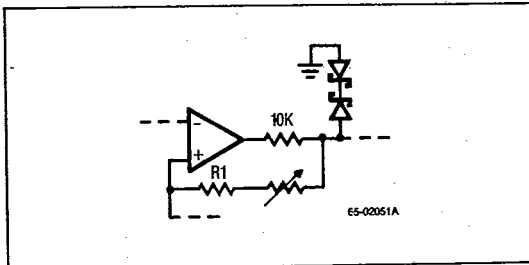

Figure 2. Triangle Generator — Symmetrical Output Option

V_R be set to obtain a triangle wave at V_2 with $\pm 12V$ amplitude. This will then allow A3 and A4 to be used for independent adjustment of output-offset and amplitude over a wide range.

The triangle wave frequency is set by C_0 , R_0 , and the maximum output voltages of the comparator. A more symmetrical waveform can be generated by adding a back-to-back zener diode pair as shown in Figure 2.

An asymmetric triangle wave is needed in some applications. Adding diodes as shown by the dashed lines is a way to vary the positive and negative slopes independently.

Frequency range can be very wide and the circuit will function very well up to about 10kHz. Transition time for the square wave at V_1 is less than $21\mu\text{s}$ when using the 4156.

Active Filters

The introduction of low-cost quad op amps has had a strong impact on active filter design. The complex multiple-feedback, single op amp filter circuits have been rendered obsolete for most applications. State-variable active-filter circuits using three to four op amps per section offer many advantages over the single op amp circuits. They are relatively insensitive to the passive-component tolerances and variations. The Q, gain, and natural frequency can be independently adjusted. Hybrid construction is very practical because resistor and capacitor values are relatively low and the filter parameters are determined by resistance ratios rather than by single resistors. A generalized circuit diagram of the 2-pole state-variable active filter is shown in Figure 3. The particular input

connections and component-values can be calculated for specific applications. An important feature of the state-variable filter is that it can be inverting or non-inverting and can simultaneously provide three outputs: lowpass, bandpass, and highpass. A notch filter can be realized by adding one summing op amp.

The Raytheon 4156 was designed and characterized for use in active filter circuits. Frequency response is fully specified with minimum values for unity-gain bandwidth, slew-rate, and full-power response. Maximum noise is specified. Output swing is excellent with no distortion or clipping. The Raytheon 4156 provides full, undistorted response up to 20kHz and is ideal for use in high-performance audio and telecommunication equipment.

In the state-variable filter circuit, one amplifier performs a summing function and the other two act as integrators. The choice of passive component values is arbitrary, but must be consistent with the amplifier operating range and input signal characteristics. The values shown for C1, C2, R4, R5 and R6 are arbitrary. Pre-selecting their values will simplify the filter tuning procedures, but other values can be used if necessary.

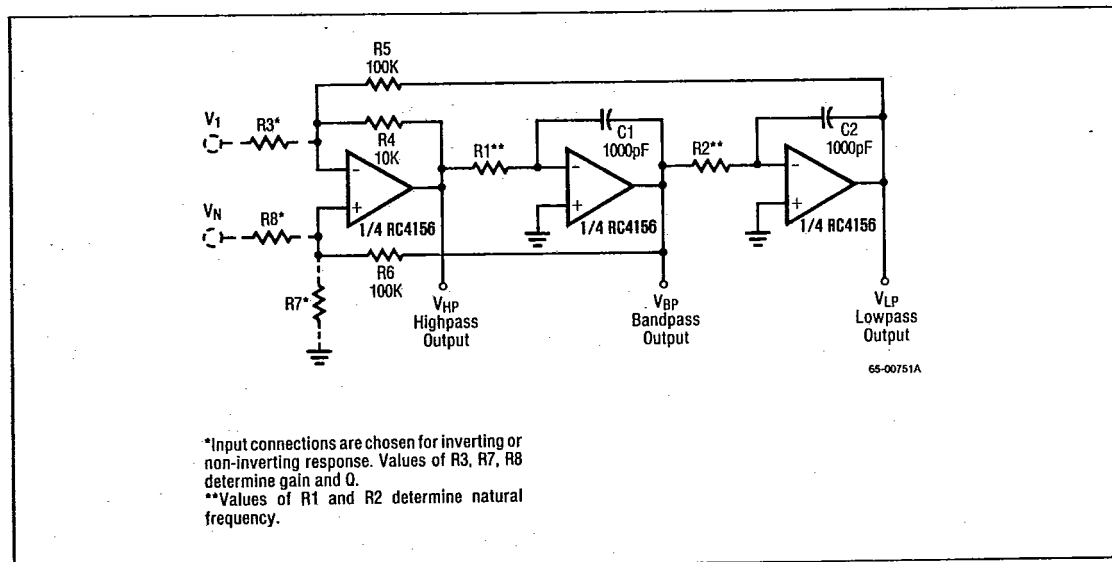

Figure 3. Generalized State-Variable Configuration for Active Filter

The generalized transfer function for the state-variable active filter is:

$$T(s) = \frac{a_2s^2 + a_1s + a_0}{s^2 + b_1s + b_0}$$

Filter response is conventionally described in terms of a natural frequency ω_0 in radians/sec, and Q, the quality of the complex pole pair. The filter parameters ω_0 and Q relate to the coefficients in T(s) as:

$$\omega_0 = \sqrt{b_0} \text{ and } Q = \frac{\omega_0}{b_1}$$

The input configuration determines the polarity (inverting or non-inverting), and the output selec-

tion determines the type of filter response (low-pass, bandpass, or highpass).

Notch and all-pass configurations can be implemented by adding another summing amplifier.

Bandpass filters are of particular importance in audio and telecommunication equipment. A design approach to bandpass filters will be shown as an example of the state-variable configuration.

Design Example — Bandpass Filter

In this example, the input signal is applied through R3 to the inverting input of the summing amplifier and the output is taken from the first integrator (V_{BP}). The summing amplifier will maintain equal voltage at the inverting and non-inverting inputs (see equation below).

$$\frac{\frac{R3R5}{R3 + R5} V_{HP}(s) + \frac{R3R4}{R3 + R4} V_{LP}(s) + \frac{R4R5}{R4 + R5} V_{IN}(s)}{R4 + \frac{R3R5}{R3 + R5}} = \frac{R7}{R6 + R7} V_{BP}(s)$$

These equations can be combined to obtain the transfer function:

$$V_{BP}(s) = -\frac{1}{R1C1S} V_{HP}(s) \text{ and } V_{LP}(s) = -\frac{1}{R2C2S} V_{BP}(s)$$

$$\frac{V_{BP}(s)}{V_{IN}(s)} = \frac{\frac{R4}{R3} \frac{1}{R1C1} s}{s^2 + \frac{R7}{R6 + R7} \left(1 + \frac{R4}{R5} + \frac{R4}{R3}\right) \left(\frac{1}{R1C1}\right) s + \frac{R4}{R5} \frac{1}{R1C1R2C2}}$$

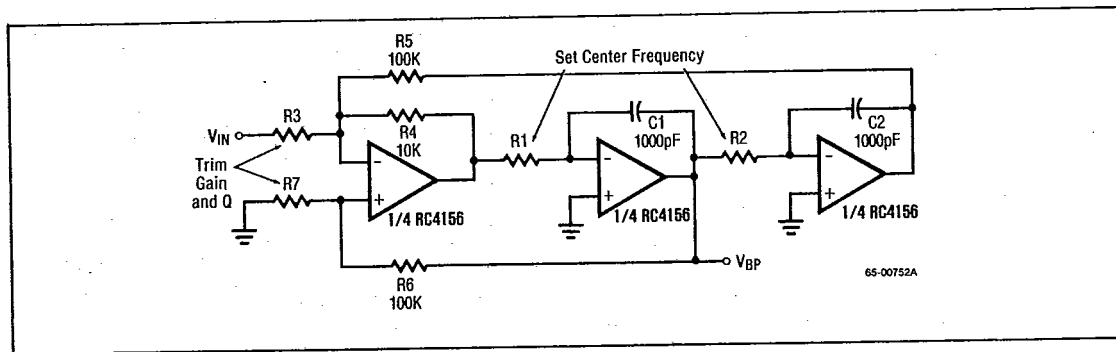

Figure 4. Bandpass Active Filter

Defining $1/R1C1$ as ω_1 , $1/R2C2$ as ω_2 , and substituting in the assigned values for R4, R5, and R6, then the transfer function simplifies to:

$$\frac{V_{BP}(s)}{V_{IN}(s)} = \frac{\frac{10^4}{R3} \omega_1 s}{s^2 + \frac{1.1 + \frac{10^4}{R3}}{1 + \frac{10^5}{R7}} \omega_1 s + \frac{0.1}{\omega_1 \omega_2}}$$

This is now in a convenient form to look at the center-frequency ω_0 and filter Q.

$$\omega_0 = \sqrt{0.1 \omega_1 \omega_2} \quad \text{and} \quad Q = \frac{1 + \frac{10^5}{R7}}{1.1 + \frac{10^4}{R3}} \omega_0$$

$$= 10^{-9} \sqrt{0.1 R1 R2}$$

The frequency response for various values of Q are shown in Figure 5.

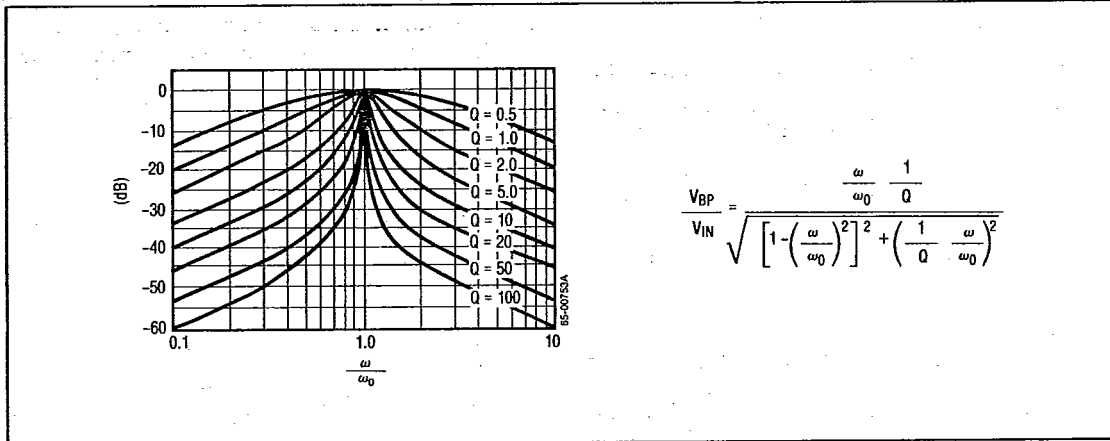

Figure 5. Bandpass Transfer Characteristics Normalized for Unity Gain and Frequency

These equations suggest a tuning sequence where ω is first trimmed via R1 or R2, then Q is trimmed by varying R7 and/or R3. An important advantage of the state-variable bandpass filter is that Q can be varied without affecting center frequency ω_0 .

This analysis has assumed ideal op amps operating within their linear range, which is a valid design approach for a reasonable range of ω_0 and Q. At extremes of ω_0 and at high values of Q, the op amp parameters become significant. A rigorous analysis is very complex, but some factors are particularly important in designing active filters.

1. The passive component values should be chosen such that all op amps are operating within their linear region for the anticipated range of input signals. Slew rate, output current rating, and common-mode input range must be considered. For the integrators, the current through the feedback capacitor

($I = C \text{ dV/dt}$) should be included in the output current computations.

2. From the equation for Q, it would seem that infinite Q could be obtained by making R7 zero. But as R7 is made small, the Q becomes limited by the op amp gain at the frequency of interest. The effective closed-loop gain is being increased directly as R7 is made smaller, and the ratio of open-loop gain to closed-loop gain is becoming less. The gain and phase error of the filter at high Q is very dependent on the op amp open-loop gain at ω_0 .
3. The attenuation at extremes of frequency is limited by the op amp gain and unity-gain bandwidth. For integrators, the finite open-loop op amp gain limits the accuracy at the low-end. The open-loop roll-off of gain limits the filter attenuation at high frequency.

RC4156

High Performance Quad Operational Amplifier

The Raytheon 4156 quad operational amplifier has much better frequency response than a conventional 741 circuit and is ideal for active filter use. Natural frequencies of up to 10kHz are readily achieved and up to 20kHz is practical for some configurations. Q can range up to 50 with very

good accuracy and up to 500 with reasonable response. The extra gain of the 4156 at high frequencies gives the Raytheon quad op amp an extra margin of performance in active-filter circuits.