

TOY CAR REMOTE CONTROLLER WITH FIVE FUNCTIONS

DESCRIPTION

The TX-2B/RX-2C is a pair of CMOS LSIs designed for remote controlled car applications. The TX-2B/RX-2C has five control keys for controlling the motions (i.e. forward, backward, rightward, leftward and the turbo function) of the remote controlled car.

FEATURES

- * Wide operating voltage range ($V_{CC}=1.8V\sim 5.0V$ when DC-DC is not used and $V_{CC}=1.0V\sim 5.0V$ when DC-DC is used)
- * Low stand-by current
- * In order to be used in the low voltage condition, the DC-DC is added in RX-2C; you can decide whether to use DC-DC; the voltage to turn on is 1.0V ; and the voltage to work is 0.8V ; and the output voltage is 3.0V ;
- * Auto-power-off function for TX-2B
- * Few external components are needed

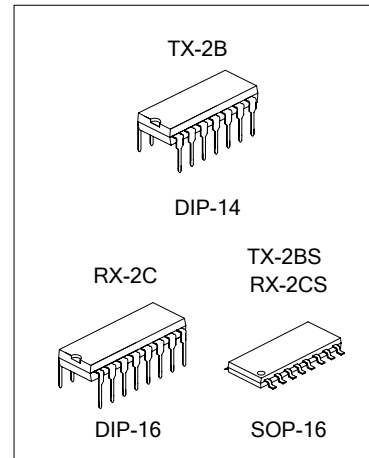

ORDERING INFORMATION

Device	Package
TX-2B	DIP-14-300-2.54
TX-2BS	SOP-16-225-1.27
RX-2C	DIP-16-300-2.54
RX-2CS	SOP-16-225-1.27

BLOCK DIAGRAM

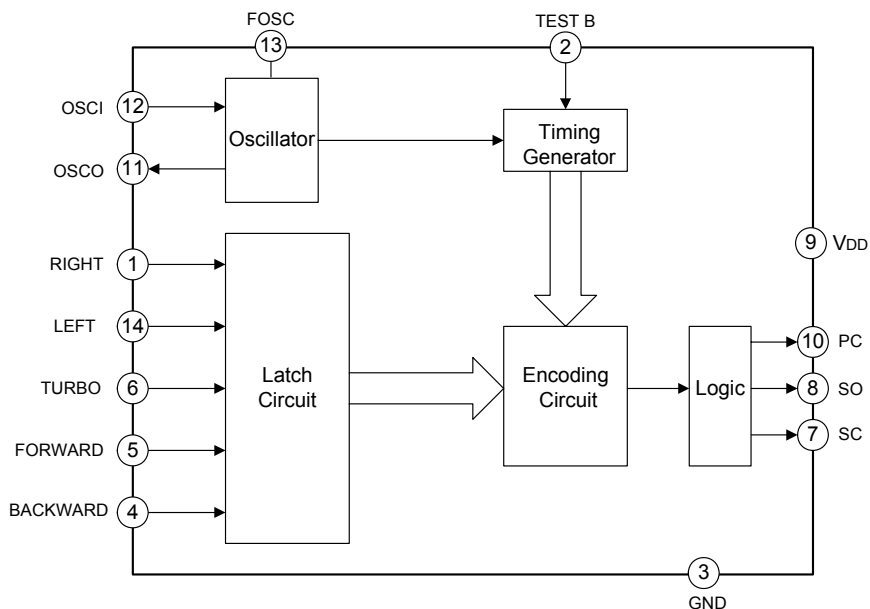

TRANSMITTER TX-2B Block Diagram

BLOCK DIAGRAM (continued)

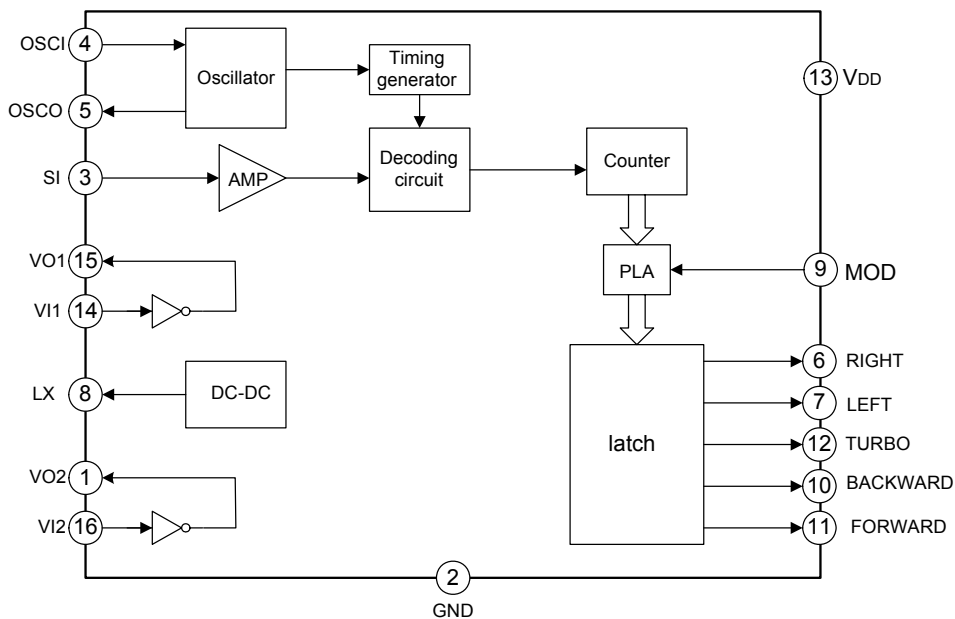

RECEIVER RX-2C Block Diagram

ABSOLUTE MAXIMUM RATINGS

Characteristics	Symbol	Value	Unit
Supply Voltage	VDC	0.3~6.0	V
Input / Output Voltage	V _{I/O}	GND-0.2~V _{DD} +0.2	V
Storage Temperature	T _{stg}	-10~60	°C
Operating Temperature	T _{opr}	-25~125	°C

ELECTRICAL CHARACTERISTICS

1. TX-2B(V_{DD}=4.5V, F_{osc}=128 KHz, T_{amb}=25°C, unless otherwise specified.)

Characteristics	Symbol	Test conditions	Min.	Typ.	Max.	Unit
Operating Voltage	V _{DD}		1.8	4.5	5.0	V
Low Voltage input	V _{IL}	Function input pin	--	--	2.3	V
Stand-By Current	I _{STB}	No input	--	--	3.0	μA
Operating Current	I _{DD}	Output without load	--	--	0.4	mA
SO Driving Current	I _{DRSO}	Load=0.7V	20			mA
SC Driving Current	I _{DRSC}	Load=0.7V	20			mA
PC Driving Current	I _{DRPC}	Load=0.7V	15			mA
Tolerance of frequency	F _{tolerance}	RX-2C oscillator 128KHz	-20		+20	%

2. RX-2C (VDD=4.0V, Fosc=128KHz, Tamb=25°C, DC-DC is not used, unless otherwise specified.)

Characteristics	Symbol	Test conditions	Min.	Typ.	Max.	Unit
Operating Voltage	VDD		1.8	4.5	5.0	V
Operating Current	IDD	Output without load	--	--	1.0	mA
Driving Current	I _{drive}	Load=0.7V	4.5	--	--	mA
Tolerance of frequency	F _{tolerance}	TX-2B 128KHz	-20		+20	%

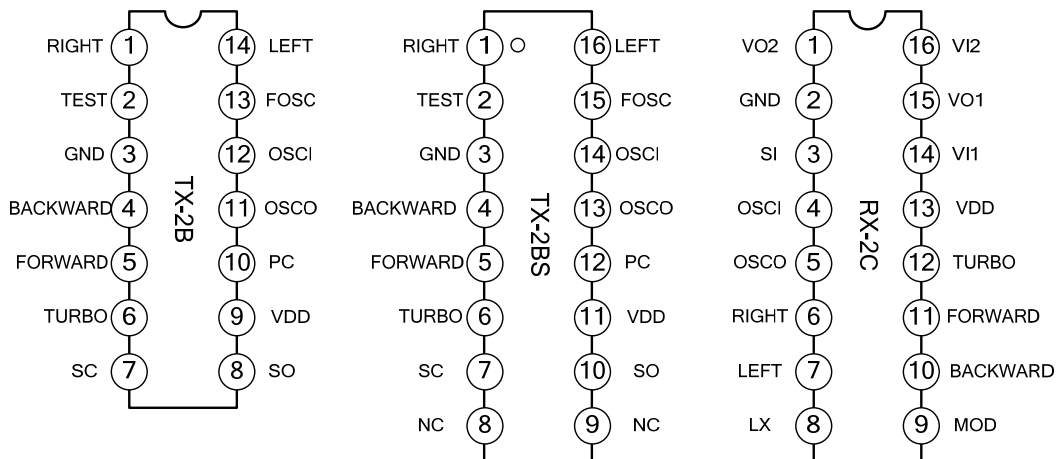
PIN CONFIGURATION

PIN DESCRIPTION
1. TX-2B/TX-2BS

Pin No.		Symbol	Description
TX-2B	TX-2BS		
1	1	RIGHT	The rightward function will be selected, if this pin is connected to GND
2	2	TEST	test pin
3	3	GND	Negative power supply
4	4	BACKWARD	The backward function will be selected, if this pin is connected to GND
5	5	FORWARD	The forward function will be selected, if this pin is connected to GND
6	6	TURBO	The turbo function will be selected if this pin is connected to GND
7	7	SC	Output pin of the encoding signal with carrier frequency
--	8, 9	NC	Not connect
8	10	SO	Output pin of the encoding signal without carrier frequency
9	11	VDD	Positive power supply
10	12	PC	Power control output pin
11	13	OSCO	Oscillator output pin
12	14	OSCI	Oscillator input pin
13	15	FOSC	Oscillate frequency output
14	16	LEFT	The leftward function will be selected, if this pin is connected to GND

2. RX-2C

Pin No.	Symbol	Description
1	VO2	Inverter 2 output pin for power amplify
2	GND	Negative power supply
3	SI	Input pin of the encoding signal
4	OSCI	Oscillator input pin
5	OSCO	Oscillator output pin
6	RIGHT	Rightward output pin
7	LEFT	Leftward output pin
8	LX	DC-DC output pin
9	MOD	Output pin (pull up) to decide the format of output sign, RX-2C is same with RX2 if the pin is high, and if the pin is low, RX-2C output another sign format.
10	BACKWARD	Backward output pin
11	FORWARD	Forward output pin
12	TURBO	TURBO output pin
13	VDD	Positive power supply
14	VI1	Inverter 1 input pin for power amplify
15	VO1	Inverter 1 output pin for power amplify
16	VI2	Inverter 2 input pin for power amplify

FUNCTION DESCRIPTION

CODE FORMAT

1. ENCODE RULE

(A).Bit Forma (W1 is used for function codes, W2 for start codes)

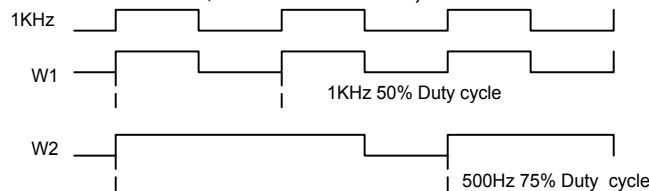

(B).DATE FORMAT

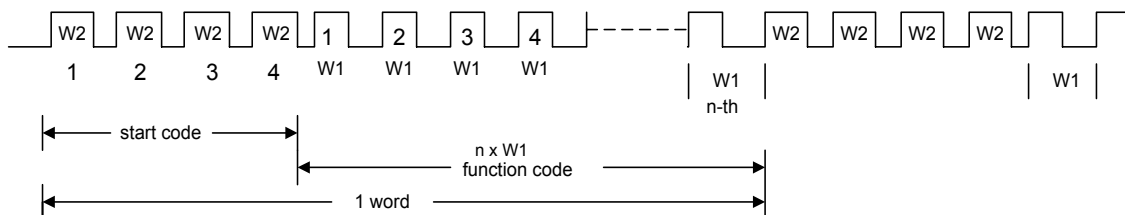
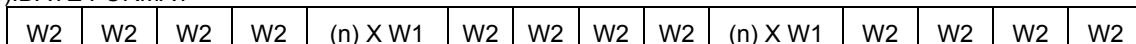

Number Of Function Code (N) W1	Function Key	Decode Result
4		End Code
10	Forward	Forward
16	Forward & Turbo	Forward
22	Turbo	Turbo
28	Turbo & Forward & Left	Forward & Left
34	Turbo & Forward & Right	Forward & Right
40	Backward	Backward
46	Backward & Right	Backward & Right
52	Backward & Left	Backward & Left
58	Left	Left
64	Right	Right

2. ENCODE/DECODE TIMING

(A)

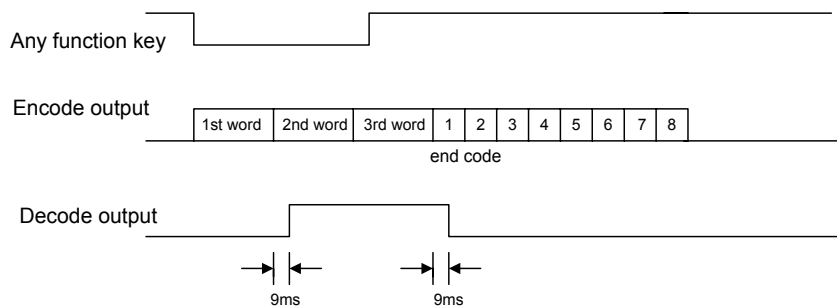

(B)

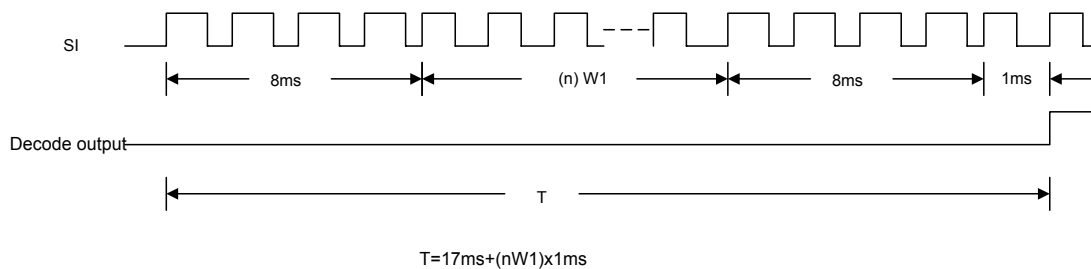

FUNCTION

Function key (TX-2B) ①	command (RX-2C,MOD=1) ②	Command(RX-2C,MOD=0) ③
	Over code	Over code
forward	forward	Forward pulse (50Hz 50%Duty)
Forward and turbo	forward	Forward and turbo
turbo	turbo	Forward and turbo
Forward and turbo and left	Forward and left	Forward and left Forward pulse (50Hz 50%Duty)

(To be continued)

(Continued)

Function key (TX-2B) ①	command (RX-2C,MOD=1) ②	Command(RX-2C,MOD=0) ③
Forward and turbo and right	Forward and right	Forward and right Forward pulse (50Hz 50%Duty)
Backward	Backward	Backward Backward pulse (50Hz 50%Duty)
Backward and right	Backward and right	Backward and right Backward pulse (50Hz 50%Duty)
Backward and left	Backward and left	Backward and left Backward pulse (50Hz 50%Duty)
Left	Left	Left
Right	Right	Right

Note: when a key is low voltage, it is an input key.

②,③ high voltage format is used when there is no output format.

TEST CIRCUIT

The oscillator frequency of TX-2B and RX-2C is 116 ~140 kHz

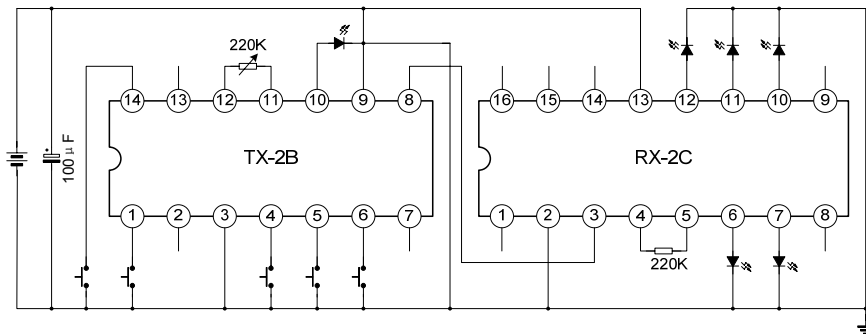

TYPICAL APPLICATION CIRCUIT

Transmitter (TX-2B $F_{osc}=116\sim140kHz$)

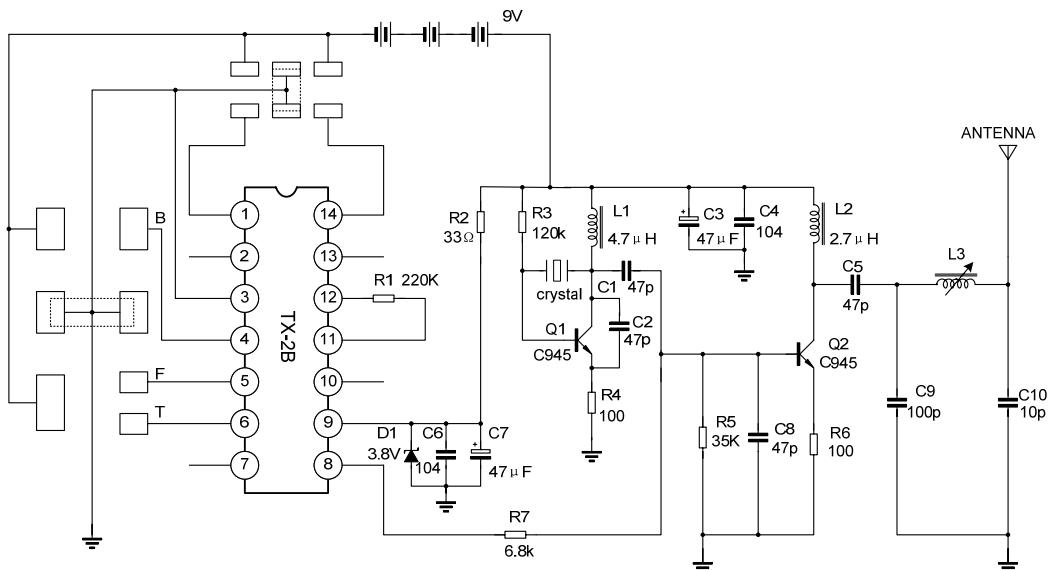

RECEIVER I (RX-2C Fosc=128 kHz)

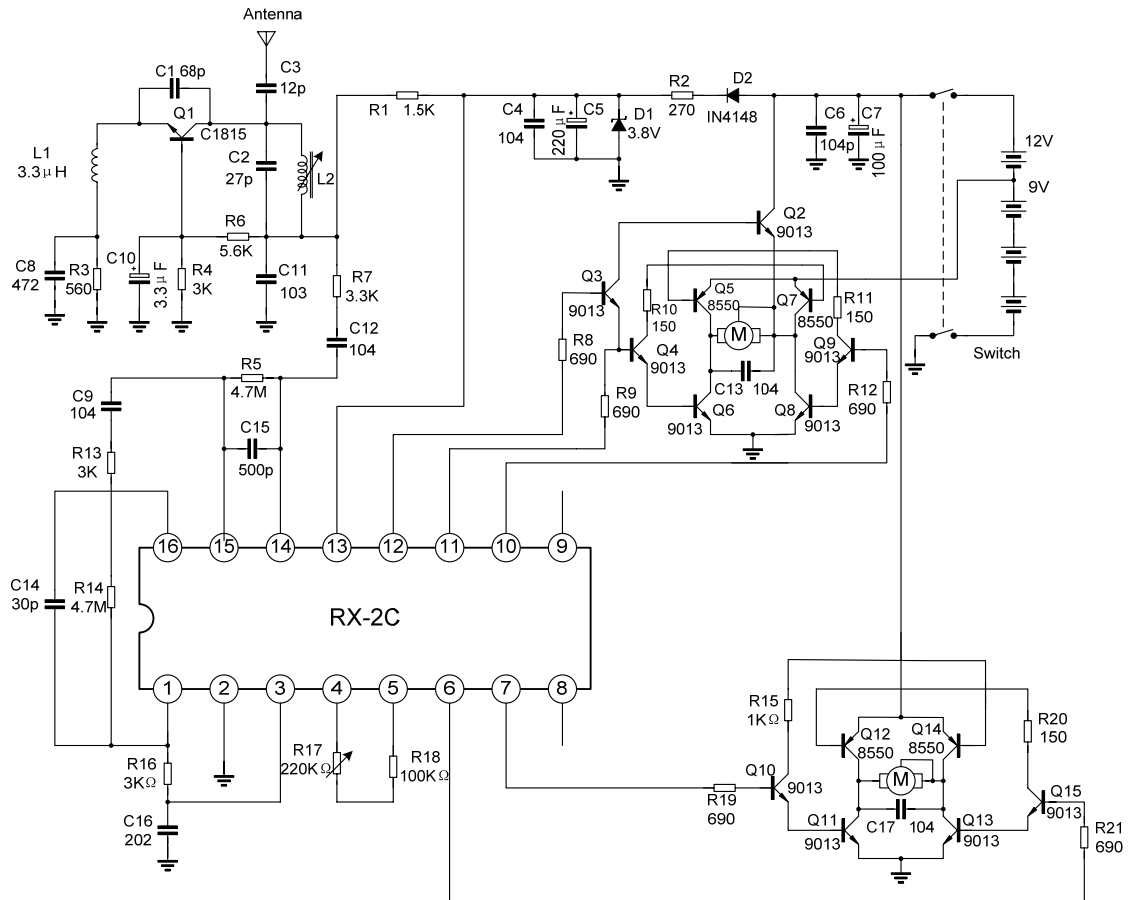

- Note:1. MOD=1(MOD pin opens)
 2. No using DC-DC converter because of higher supply voltage
 3. Two grade shift gears are realized.

RECEIVER II (RX-2C FOSC=116~140 kHz)

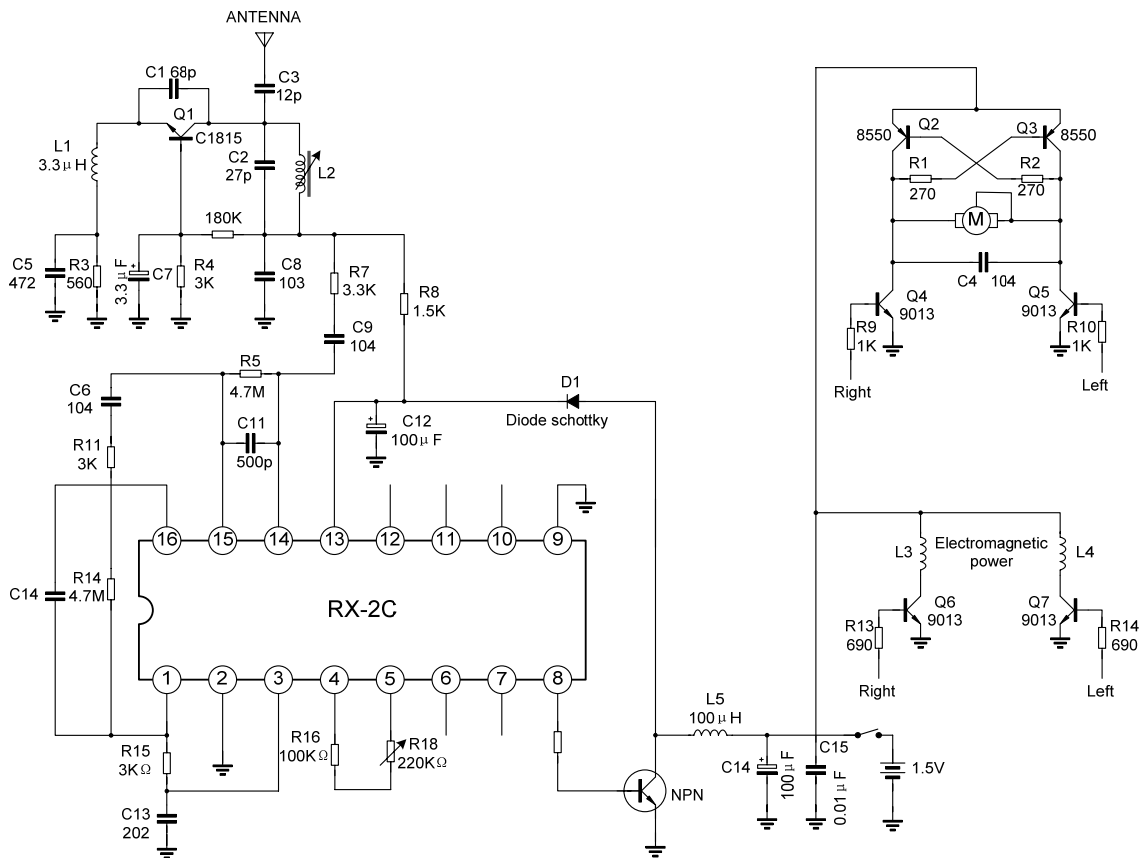

Note:1. MOD=0(pulled low)

2. Using DC-DC converter because of low supply voltage
3. Two grade shift gears are realized.

INFRARED APPLICATION CIRCUIT

Transmitter (TX-2B $F_{osc}=114\text{ kHz}$)

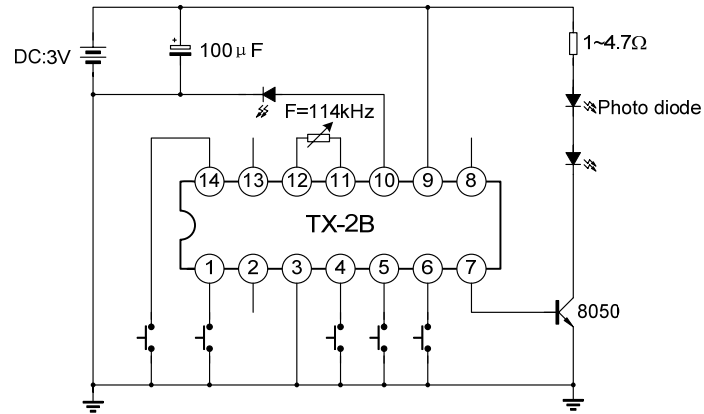

Receiver (RX-2C $F_{osc}=114\text{ kHz}$)

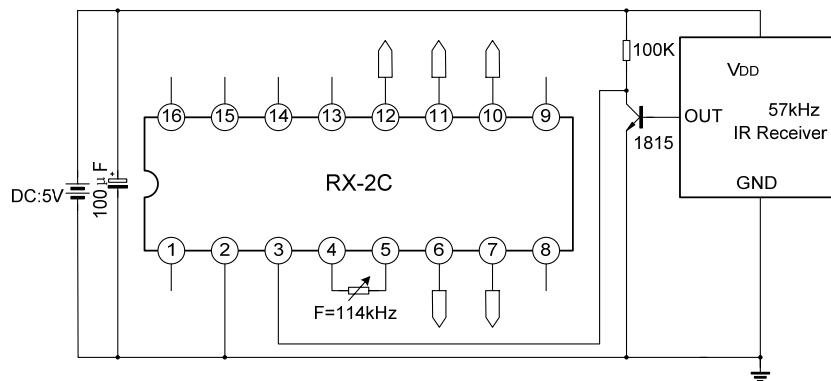

PACKAGE OUTLINE

DIP-14-300-2.54

UNIT: mm

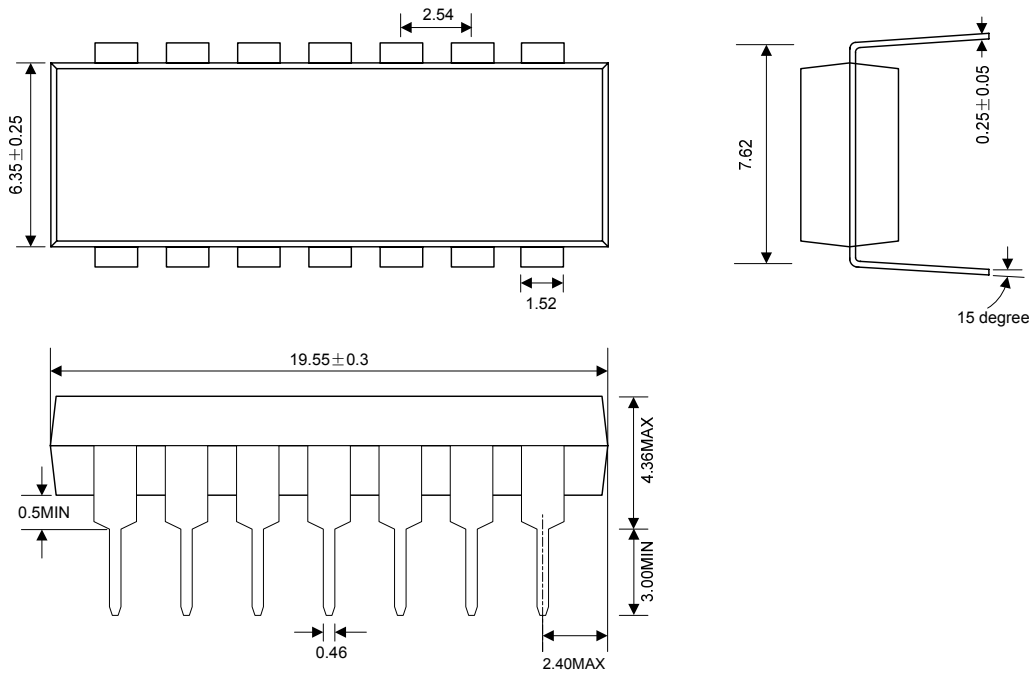

SOP-14-225-1.27

UNIT: mm

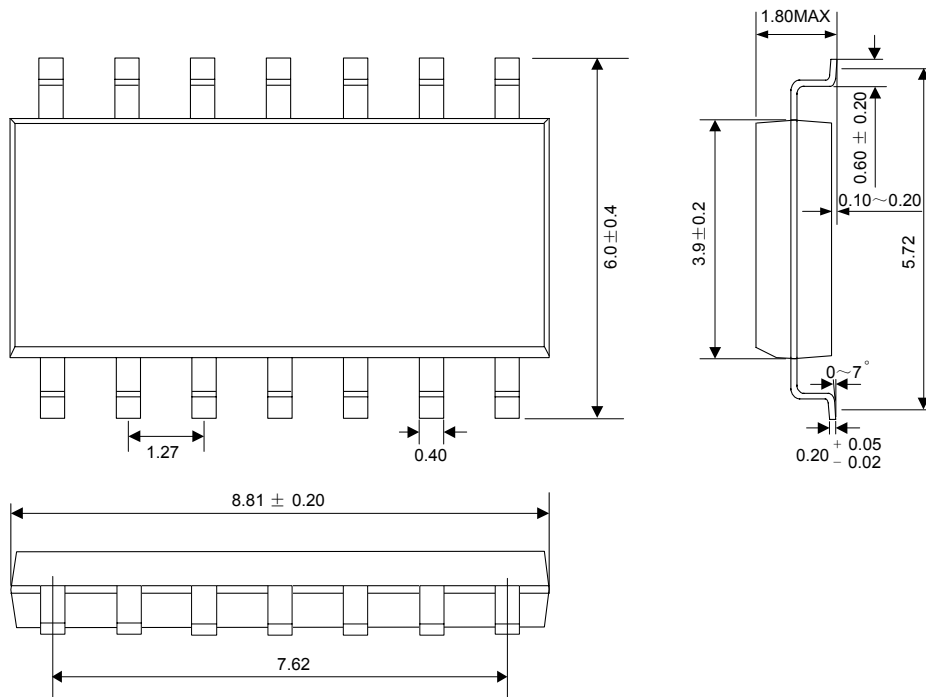

PACKAGE OUTLINE (continued)

DIP-16-300-2.54

UNIT: mm

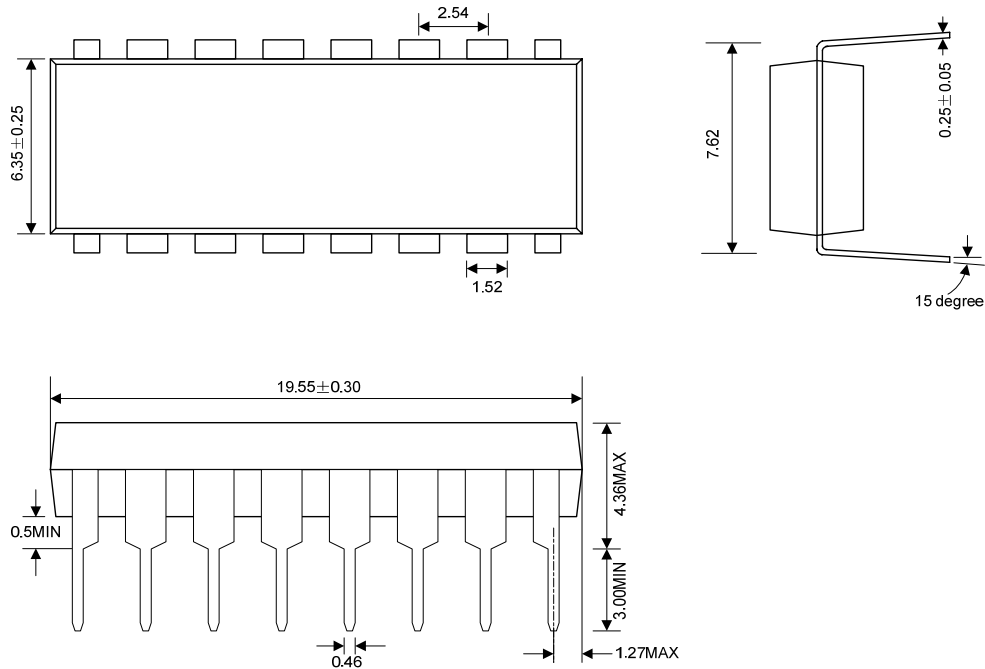

SOP-16-225-1.27

UNIT: mm

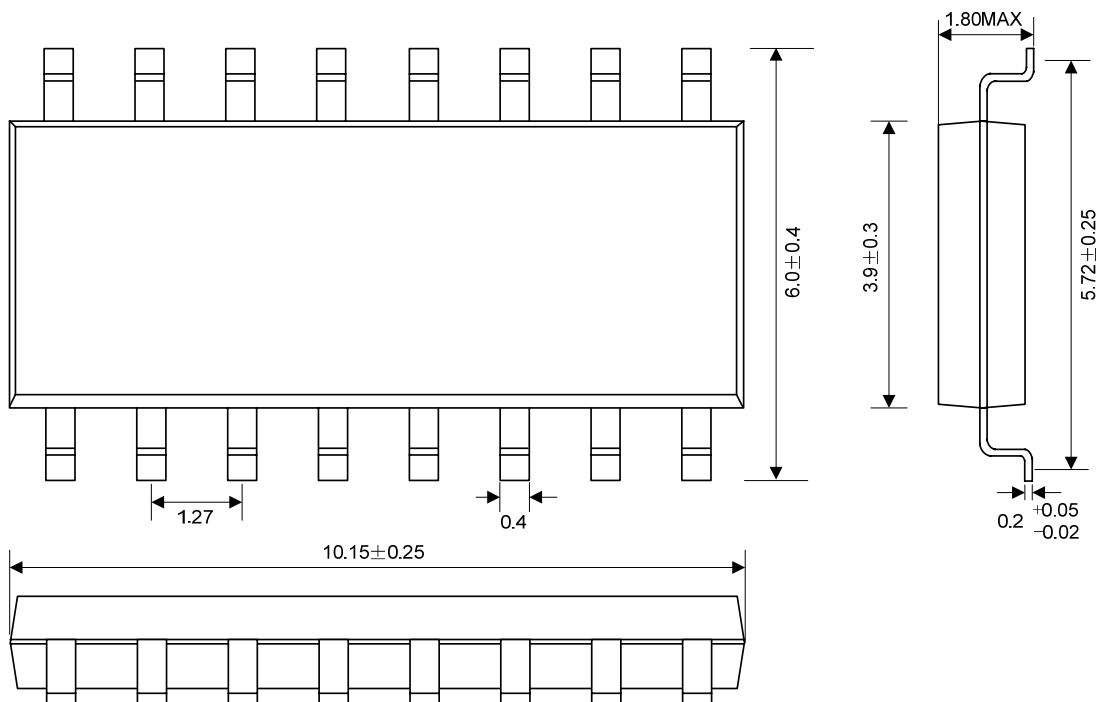



MOS DEVICES OPERATE NOTES:

Electrostatic charges may exist in many things. Please take following preventive measures to prevent effectively the MOS electric circuit as a result of the damage which is caused by discharge:

- The operator must put on wrist strap which should be earthed to against electrostatic.
- Equipment cases should be earthed.
- All tools used during assembly, including soldering tools and solder baths, must be earthed.
- MOS devices should be packed in antistatic/conductive containers for transportation.

Note: Silan reserves the right to make changes without notice in this specification for the improvement of the design and performance.
Silan will supply the best possible product for customers.