



**RAYSTAR**

# 曜凌光電股份有限公司

住址: 42878 台中市大雅区科雅路 25 號 5F  
5F., No.25, Keya Rd., Daya Dist., Taichung  
City 428, Taiwan

WEB: <http://www.Raystar-Optronics.com>  
E-mail: sales@raystar-optronics.com  
Tel:886-4-2565-0761 Fax : 886-4-2565-0760

## RX12864B-TIW

---

### SPECIFICATION

CUSTOMER:

APPROVED BY	
PCB VERSION	
DATE	

FOR CUSTOMER USE ONLY

SALES BY	APPROVED BY	CHECKED BY	PREPARED BY

ISSUED DATE:

# Contents

	Page
1. Revision History	3
2. General Specification	4
3. Module Coding System	5
4. Interface Pin Function	6
5. Outline dimension & Block Diagram	7
6. Timing Characteristics	8
7. Display Command	11
8. Optical Characteristics	12
9. Absolute Maximum Ratings	13
10. Electrical Characteristics	13
11. Backlight Information	14
12. Reliability	15
13. Inspection specification	16
14. Precautions in use of LCD Modules	20
15. Material List of Components for RoHs	21
16. Recommendable storage	21

## 1. Revision History

DATE	VERSION	REVISED PAGE NO.	Note
2012/11/28	1		First issue

RAYSTAR OPTRONICS

## 2. General Specification

The Features of the Module is description as follow:

- Module dimension: 89.7x 49.8 x 12.1 (max.) mm<sup>3</sup>
- View area: 69.0 x 36.5 mm<sup>2</sup>
- Active area: 63.97 x31.97 mm<sup>2</sup>
- Number of Dots: 128 x 64
- Dot size: 0.47 x0.47 mm<sup>2</sup>
- Dot pitch: 0.5 x 0.5 mm<sup>2</sup>
- LCD type: FSTN Negative Transmissive
- Duty: 1/65
- View direction: 6 o'clock
- Backlight Type: LED, White

### 3. Module Coding System

<b>R</b>	<b>X</b>	<b>12864</b>	<b>B</b>	<b>-</b>	<b>T</b>	<b>I</b>	<b>W</b>
1	2	3	4	-	5	6	7

Item	Description		
1	<b>R : Raystar Optronics Inc.</b>		
2	Display Type: COG		
3	Number of dots : <b>128 x64 Dots</b>		
4	Serials code		
5	LCD	P : TN Positive, Gray	
		N : TN Negative,	
		G : STN Positive, Gray	
		Y : STN Positive, Yellow Green	
		B : STN Negative, Blue	
		F : FSTN Positive	
		<b>T : FSTN Negative</b>	
6	Polarizer Type, Temperature range, View direction	A : Reflective, N.T, 6:00	K : Transflective, W.T,12:00
		D : Reflective, N.T, 12:00	1 : Transflective, U.T,6:00
		G : Reflective, W. T, 6:00	4 : Transflective, U.T.12:00
		J : Reflective, W. T, 12:00	C : Transmissive, N.T,6:00
		0 : Reflective, U. T, 6:00	F : Transmissive, N.T,12:00
		3 : Reflective, U. T, 12:00	<b>I : Transmissive, W. T, 6:00</b>
		B : Transflective, N.T,6:00	L : Transmissive, W.T,12:00
		E : Transflective, N.T.12:00	2 : Transmissive, U. T, 6:00
		H : Transflective, W.T,6:00	5 : Transmissive, U.T,12:00
7	Backlight	N : Without backlight	Y : LED, Yellow Green
		P : EL, Blue green	A : LED, Amber
		T : EL, Green	<b>W : LED, White</b>
		D : EL, White	O : LED, Orange
		F : CCFL, White	G : LED, Green

## 4. Interface Pin Function

Pin No.	Symbol	I/O	Description
1	/CS1B	I	This is the chip select signal.
2	/RES	I	When RES is set to "L", the setting are initialized.
3	A0	I	This is connect to the least significant bit of the Norman MPU address bus, and it determines whether the data bits are data or a command.
4	/WR(R/W)	I	The data bus are latched at the rising edge of the WR signal
5	/RD(E)	I	The data bus is in output status when this signal is "L"
6~13	D0~ D7	I/O	This is an 8-bit bi-directional data bus that connects to an 8-bit or 16-bit standard MPU data bus.
14	VDD	Power Supply	Power supply
15	VSS	Power Supply	Ground
16	VOUT	O	DC/DC voltage converter. Connect a capacitor between this terminal and vss or VDD
17	CAP3P	O	DC/DC voltage converter. Connect a capacitor between this terminal and the CAP1N terminal.
18	CAP1N	O	DC/DC voltage converter. Connect a capacitor between this terminal and the CAP1P terminal.
19	CAP1P	O	DC/DC voltage converter. Connect a capacitor between this terminal and the CAP1N terminal.
20	CAP2P	O	DC/DC voltage converter. Connect a capacitor between this terminal and the CAP2N terminal.
21	CAP2N	O	DC/DC voltage converter. Connect a capacitor between this terminal and the CAP2P terminal.
22~26	V4~ V0	Power Supply	This is a multi-level power supply for the liquid crystal drive.
27	VR	I	Output voltage regulator terminal. Provides the voltage between VSS and V0 through a resistive voltage divider.
28	C86	I	This is the MPU interface switch terminal.
29	P/S	I	This is the parallel data input/serial data input switch terminal.
30	NC	-	No connection.

# 5. Outline Dimension & Block Diagram

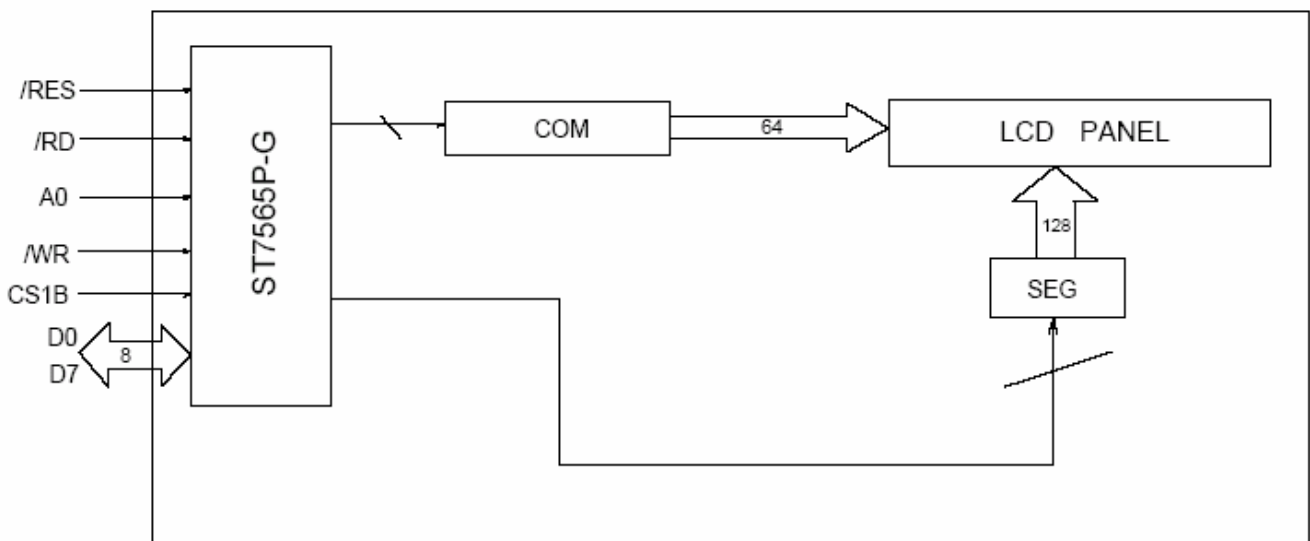
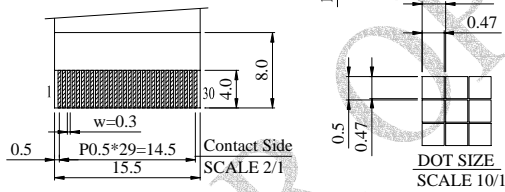
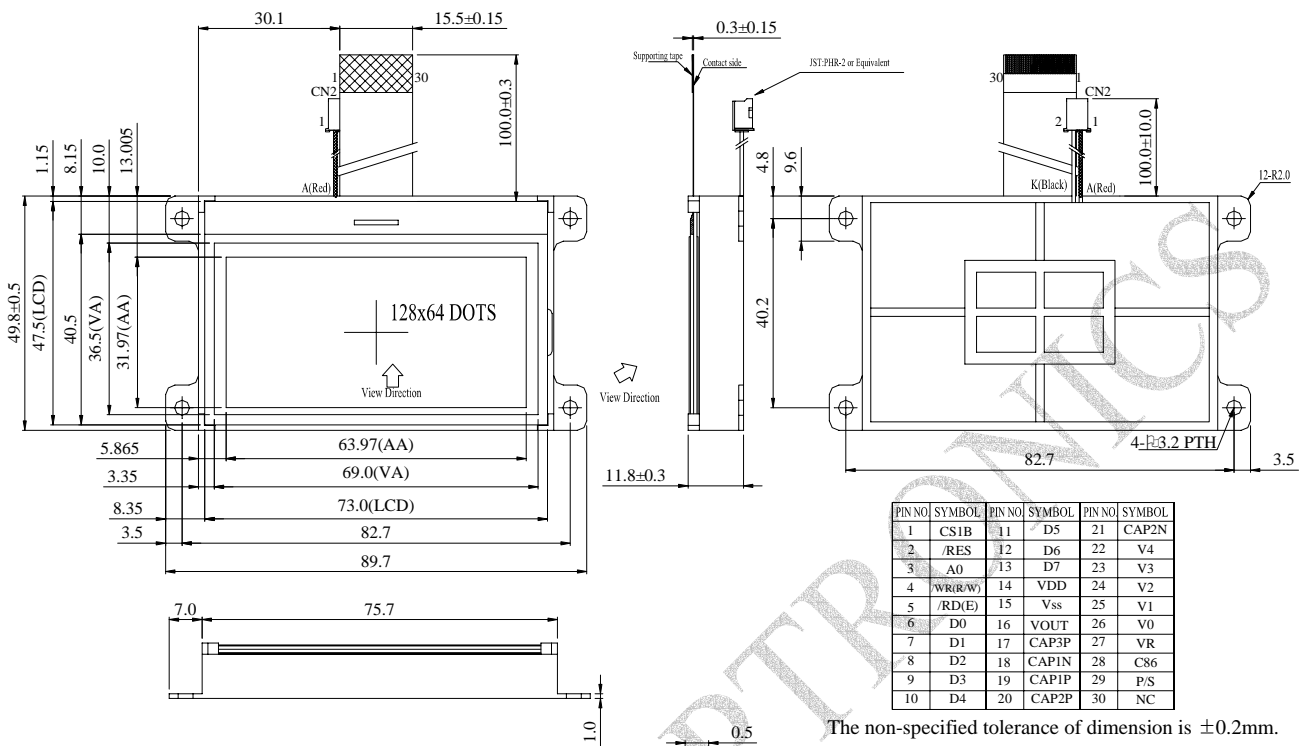

## 6. Timing Characteristics

### 6-1. 8080 Series MPU

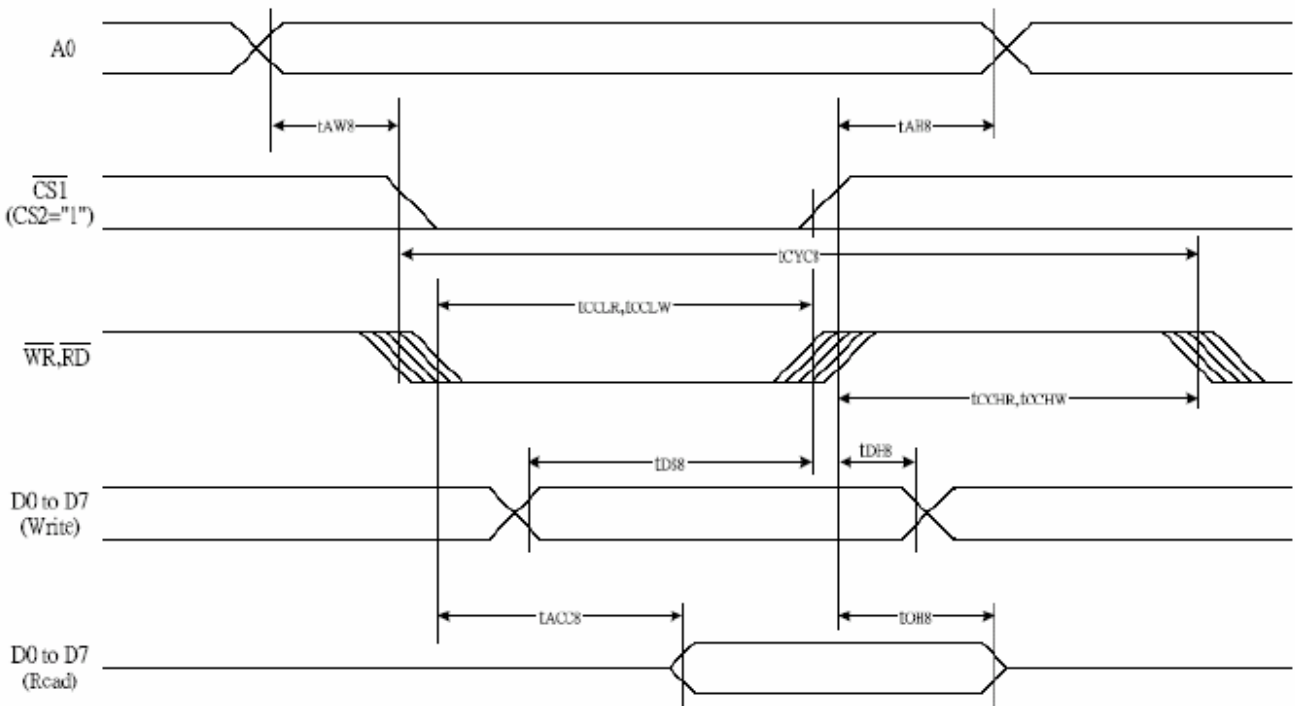

RAYSTAR



(V<sub>DD</sub> = 3.3V, T<sub>a</sub> = 25°C)

Item	Signal	Symbol	Condition	Rating		Units
				Min.	Max.	
Address hold time	A0	t <sub>AH8</sub>		0	—	Ns
Address setup time		t <sub>AW8</sub>		0	—	
System cycle time		t <sub>CYC8</sub>		240	—	
Enable L pulse width (WRITE)	WR	t <sub>CCLW</sub>		80	—	
Enable H pulse width (WRITE)		t <sub>CCHW</sub>		80	—	
Enable L pulse width (READ)	RD	t <sub>CCLR</sub>		140	—	
Enable H pulse width (READ)		t <sub>CCHR</sub>		80	—	
WRITE Data setup time	D0 to D7	t <sub>DS8</sub>		40	—	
WRITE Address hold time		t <sub>DH8</sub>		0	—	
READ access time		t <sub>ACC8</sub>	CL = 100 pF	—	70	
READ Output disable time		t <sub>OH8</sub>	CL = 100 pF	5	50	

\*1 The input signal rise time and fall time (t<sub>r</sub>, t<sub>f</sub>) is specified at 15 ns or less. When the system cycle time is extremely fast, (t<sub>r</sub> + t<sub>f</sub>) ≤ (t<sub>CYC8</sub> - t<sub>CCLW</sub> - t<sub>CCHW</sub>) for (t<sub>r</sub> + t<sub>f</sub>) ≤ (t<sub>CYC8</sub> - t<sub>CCLR</sub> - t<sub>CCHR</sub>) are specified.

\*2 All timing is specified using 20% and 80% of V<sub>DD</sub> as the reference.

\*3 t<sub>CCLW</sub> and t<sub>CCLR</sub> are specified as the overlap between /CS1 being "L" (CS2 = "H") and /WR and /RD being at the "L" level.

## 6-2. 6800-Series MPU

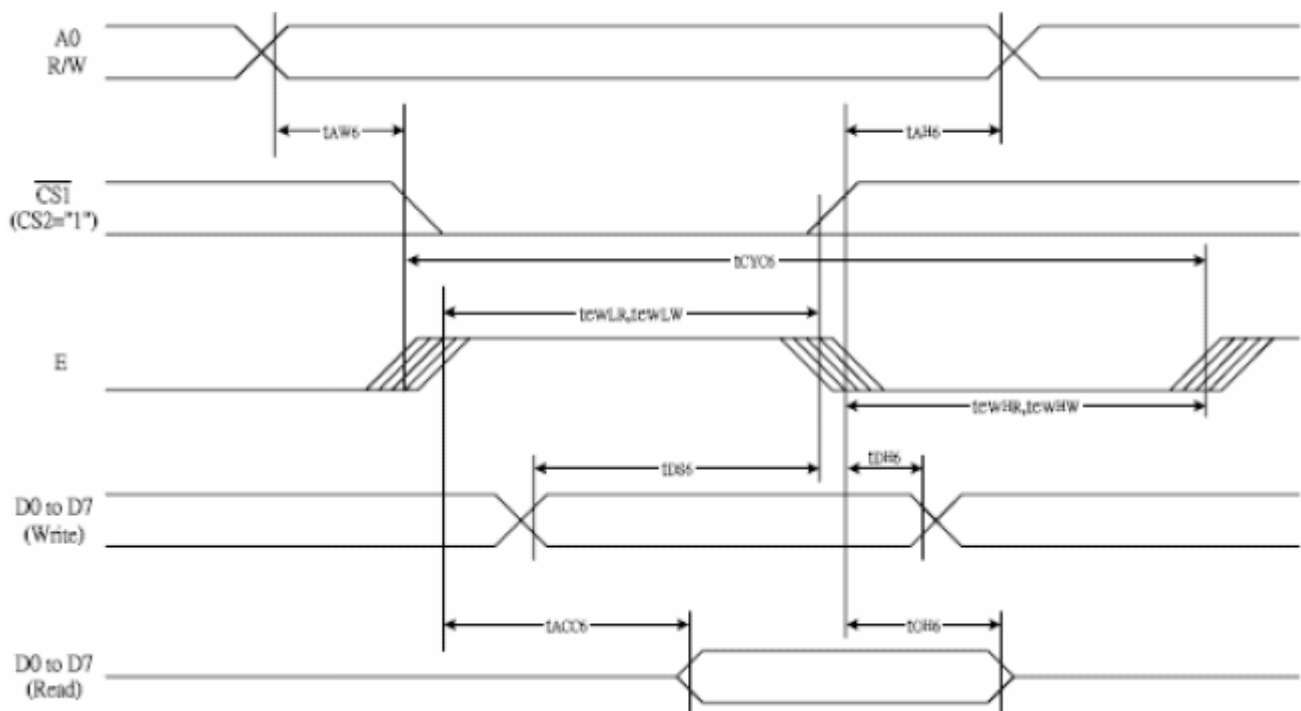

(V<sub>DD</sub> = 3.3 V, T<sub>a</sub> = 25°C)

Item	Signal	Symbol	Condition	Rating		Units
				Min.	Max.	
Address hold time	A0	t <sub>AH6</sub>		0	—	ns
Address setup time		t <sub>AW6</sub>		0	—	
System cycle time		t <sub>CYC6</sub>		240	—	
Enable L pulse width (WRITE)	WR	t <sub>EWLW</sub>		80	—	
Enable H pulse width (WRITE)		t <sub>EWHW</sub>		80	—	
Enable L pulse width (READ)	RD	t <sub>EWLR</sub>		80	—	
Enable H pulse width (READ)		t <sub>EWHR</sub>		140	—	
WRITE Data setup time	D0 to D7	t <sub>DS6</sub>		40	—	
WRITE Address hold time		t <sub>DH6</sub>		0	—	
READ access time		t <sub>ACC6</sub>	CL = 100 pF	—	70	
READ Output disable time		t <sub>OH6</sub>	CL = 100 pF	5	50	

\*1 The input signal rise time and fall time (t<sub>r</sub>, t<sub>f</sub>) is specified at 15 ns or less. When the system cycle time is extremely fast, (t<sub>r</sub> + t<sub>f</sub>) ≤ (t<sub>CYC6</sub> - t<sub>EWLW</sub> - t<sub>EWHW</sub>) for (t<sub>r</sub> + t<sub>f</sub>) ≤ (t<sub>CYC6</sub> - t<sub>EWLR</sub> - t<sub>EWHR</sub>) are specified.

\*2 All timing is specified using 20% and 80% of V<sub>DD</sub> as the reference.

\*3 t<sub>EWLW</sub> and t<sub>EWLR</sub> are specified as the overlap between CS1 being "L" (CS2 = "H") and E.

### 6-3. The Serial Interface

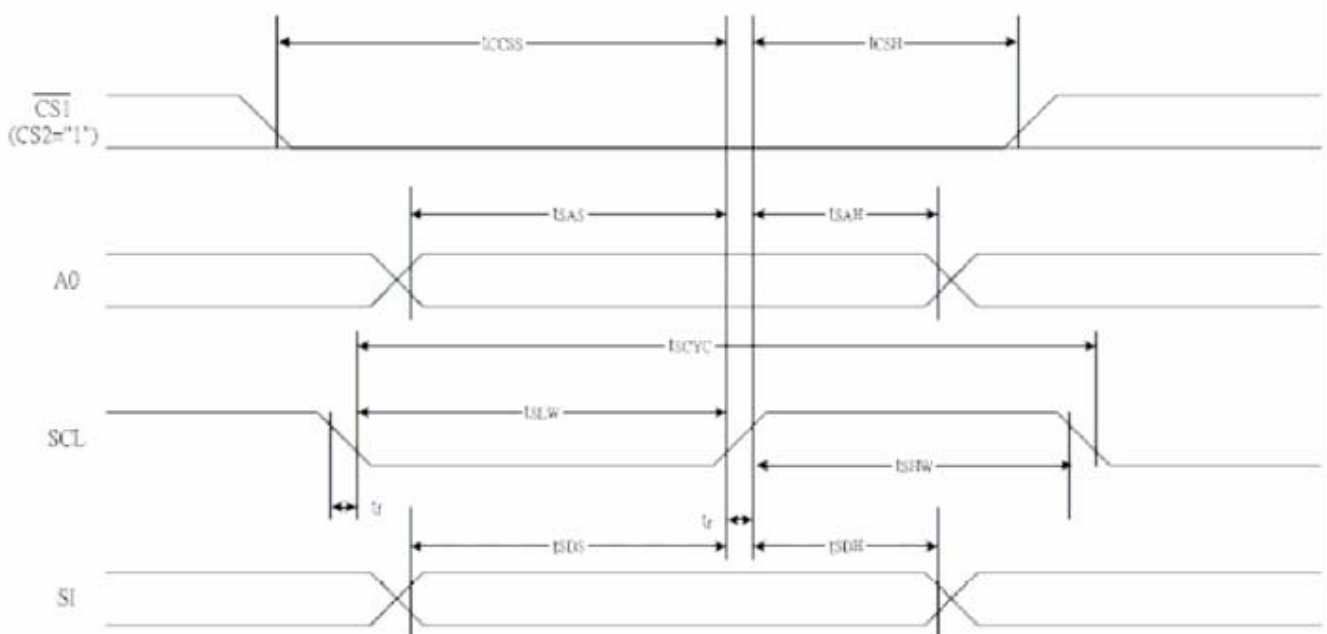

(V<sub>DD</sub> = 3.3V, T<sub>a</sub> = 25°C)

Item	Signal	Symbol	Condition	Rating		Units
				Min.	Max.	
Serial Clock Period	SCL	T <sub>soyc</sub>		50	—	ns
SCL "H" pulse width		T <sub>shw</sub>		25	—	
SCL "L" pulse width		T <sub>slw</sub>		25	—	
Address setup time	A0	T <sub>sas</sub>		20	—	
Address hold time		T <sub>сах</sub>		10	—	
Data setup time	SI	T <sub>sdс</sub>		20	—	
Data hold time		T <sub>sdh</sub>		10	—	
CS-SCL time	CS	T <sub>css</sub>		20	—	
CS-SCL time		T <sub>csn</sub>		40	—	

\*1 The input signal rise and fall time (tr, tf) are specified at 15 ns or less.

\*2 All timing is specified using 20% and 80% of V<sub>DD</sub> as the standard.

RAYSTAR OPTRO

## 7. Display Command

Command	Command Code									Function				
	A0	/RD	/WR	D7	D6	D5	D4	D3	D2		D1	D0		
(1) Display ON/OFF	0	1	0	1	0	1	0	1	1	1	0	1		
(2) Display start line set	0	1	0	0	1	Display start address						Sets the display RAM display start line address		
(3) Page address set	0	1	0	1	0	1	1	Page address				Sets the display RAM page address		
(4) Column address set upper bit	0	1	0	0	0	0	1	Most significant column address				Sets the most significant 4 bits of the display RAM column address. Sets the least significant 4 bits of the display RAM column address.		
Column address set lower bit	0	1	0	0	0	0	0	Least significant column address						
(5) Status read	0	0	1	Status				0	0	0	0		Reads the status data	
(6) Display data write	1	1	0	Write data								Writes to the display RAM		
(7) Display data read	1	0	1	Read data								Reads from the display RAM		
(8) ADC select	0	1	0	1	0	1	0	0	0	0	0	0	1	Sets the display RAM address SEG output correspondence 0: normal, 1: reverse
(9) Display normal/reverse	0	1	0	1	0	1	0	0	1	1	0	1		Sets the LCD display normal/reverse 0: normal, 1: reverse
(10) Display all points ON/OFF	0	1	0	1	0	1	0	0	1	0	0	1		Display all points 0: normal display 1: all points ON
(11) LCD bias set	0	1	0	1	0	1	0	0	0	1	0	1		Sets the LCD drive voltage bias ratio 0: 1/9 bias, 1: 1/7 bias (ST7565P)
(12) Read/modify/write	0	1	0	1	1	1	0	0	0	0	0	0		Column address increment At write: +1 At read: 0
(13) End	0	1	0	1	1	1	0	1	1	1	0			Clear read/modify/write
(14) Reset	0	1	0	1	1	1	0	0	0	1	0			Internal reset
(15) Common output mode select	0	1	0	1	1	0	0	0	*	*	*	1		Select COM output scan direction 0: normal direction 1: reverse direction
(16) Power control set	0	1	0	0	0	1	0	1	Operating mode				Select internal power supply operating mode	
(17) V <sub>0</sub> voltage regulator internal resistor ratio set	0	1	0	0	0	1	0	0	Resistor ratio				Select internal resistor ratio(R <sub>b</sub> /R <sub>a</sub> ) mode	
(18) Electronic volume mode set Electronic volume register set	0	1	0	1	0	0	0	0	0	0	0	1		Set the V <sub>0</sub> output voltage electronic volume register
(19) Static Indicator ON/OFF Static Indicator register set	0	1	0	1	0	1	0	1	1	0	0	1		0: OFF, 1: ON Set the flashing mode
(20) Booster ratio set	0	1	0	1	1	1	1	1	0	0	0	0		select booster ratio 00: 2x,3x,4x 01: 5x 11: 5x step-up value
(21) Power saver														Display OFF and display all points ON compound command
(22) NOP	0	1	0	1	1	1	0	0	0	1	1			Command for non-operation
(23) Test	0	1	0	1	1	1	1	*	*	*	*			Command for IC test. Do not use this command

## 8. Optical Characteristics

Item	Symbol	Condition	Min	Typ	Max	Unit
View Angle	$(V)\theta$	$CR \geq 2$	30	—	60	deg
	$(H)\varphi$	$CR \geq 2$	-45	—	45	deg
Contrast Ratio	CR	—	—	5	—	—
Response Time	T rise	—	—	100	280	ms
	T fall	—	—	180	330	ms

### Definition of Operation Voltage, $V_{op}$ .

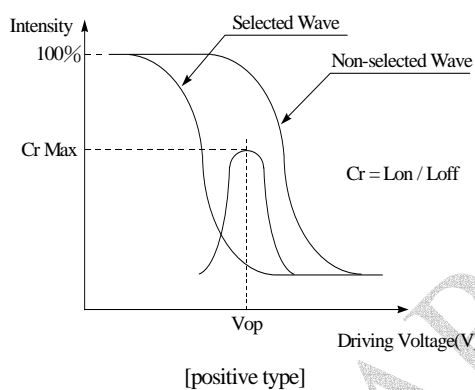

### Definition of Response Time, $T_r$ and $T_f$ .

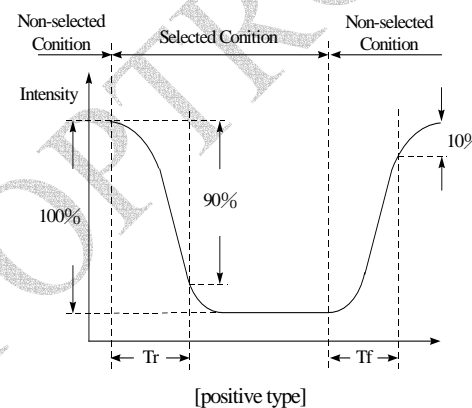

#### Conditions:

Operating Voltage :  $V_{op}$

Viewing Angle( $\theta, \varphi$ ) :  $0^\circ, 0^\circ$

Frame Frequency: 64 HZ

Driving Waveform: 1/N duty, 1/a bias

### Definition of viewing angle ( $CR \geq 2$ )

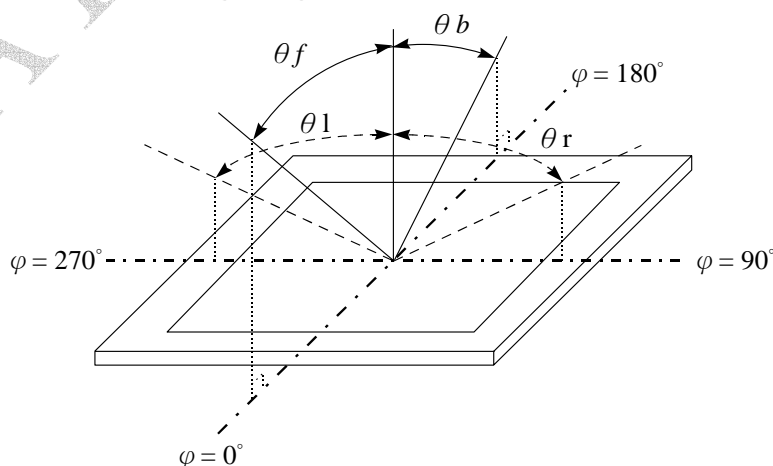

## 9. Absolute Maximum Ratings

Item	Symbol	Min	Typ	Max	Unit
Operating Temperature	$T_{OP}$	-20	—	+70	°C
Storage Temperature	$T_{ST}$	-30	—	+80	°C
Supply voltage for Logic	$V_{DD}$	0.3	—	3.6	V
Supply Voltage for LCD Driver	$V_{OUT}, V_0$	0.3		18.0	V

## 10. Electrical Characteristics

Item	Symbol	Condition	Min	Typ	Max	Unit
Supply Voltage For Logic	$V_{DD}-V_{SS}$	—	3.0	3.3	3.6	V
Supply Voltage For LCM	$V_{SS}-V_5$	$T_a=-20^{\circ}C$	9.5	9.8	10.5	V
		$T_a=25^{\circ}C$	9.25	9.45	9.65	V
		$T_a=70^{\circ}C$	8.95	9.2	9.45	V
Input High Volt.	$V_{IH}$	—	$0.8 V_{DD}$	—	$V_{DD}$	V
Input Low Volt.	$V_{IL}$	—	Vss	—	$0.2 V_{DD}$	V
Output High Volt.	$V_{OH}$	$I_{OUT}=-0.5mA$	$0.8 V_{DD}$	—	$V_{DD}$	V
Output Low Volt.	$V_{OL}$	$I_{OUT}=0.5mA$	Vss	—	$0.2V_{DD}$	V
Supply Current(No include LED Backlight)	$I_{DD}$	$V_{DD}=3.3V$		0.60	2.0	mA

NOTE: 1) Duty ratio=1/65, Bias=1/9

2) Measured in Dots ON-state

Please kindly consider to design the Vop to be adjustable while programing the software to match LCD contrast tolerance.

## 11. Backlight Information

### Specification

PARAMETER	SYMBOL	MIN	TYP	MAX	UNIT	TEST CONDITION
Supply Current	I <sub>LED</sub>	61.2	72	100	mA	V=3.5V
Supply Voltage	V	3.4	3.5	3.6	V	
Reverse Voltage	V <sub>R</sub>	—	—	5	V	—
Luminous Intensity (Without LCD)	I <sub>V</sub>	600	800	—	CD/M <sup>2</sup>	I <sub>LED</sub> =72mA
Wave Length	X	0.27	0.3	0.33		I <sub>LED</sub> =72mA
	Y	0.26	0.29	0.32		
LED Life Time	—	—	50000	—	Hr.	I <sub>LED</sub> ≤ 72mA
Color	White					

**Note:** The LED of B/L is drive by current only ; driving voltage is only for reference  
To make driving current in safety area (waste current between minimum and maximum).

**Note1 :**50K hours is only an estimate for reference.

LED B\L Drive Method

1. Drive from A , K

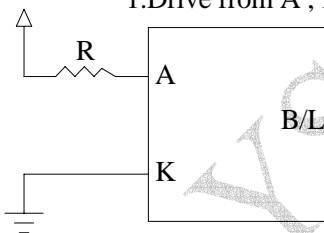

## 12. Reliability

### Content of Reliability Test (wide temperature, -20°C~70°C)

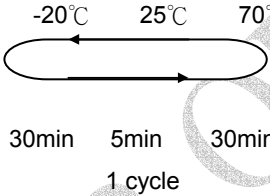
Environmental Test			
Test Item	Content of Test	Condition	Note
High Temperature storage	Endurance test applying the high storage temperature for a long time.	80°C 200hrs	2
Low Temperature storage	Endurance test applying the low storage temperature for a long time.	-30°C 200hrs	1,2
High Temperature Operation	Endurance test applying the electric stress (Voltage & Current) and the thermal stress to the element for a long time.	70°C 200hrs	-
Low Temperature Operation	Endurance test applying the electric stress under low temperature for a long time.	-20°C 200hrs	1
High Temperature/ Humidity Operation	The module should be allowed to stand at 60°C,90%RH max For 96hrs under no-load condition excluding the polarizer, Then taking it out and drying it at normal temperature.	60°C,90%RH 96hrs	1,2
Thermal shock resistance	The sample should be allowed stand the following 10 cycles of operation 	-20°C/70°C 10 cycles	-
Vibration test	Endurance test applying the vibration during transportation and using.	fixed amplitude: 15mm Vibration. Frequency: 10~55Hz. One cycle 60 seconds to 3 directions of X,Y,Z for Each 15 minutes	3
Static electricity test	Endurance test applying the electric stress to the terminal.	VS=800V,RS= 1.5kΩ CS=100pF 1 time	—

**Note1: No dew condensation to be observed.**

**Note2: The function test shall be conducted after 4 hours storage at the normal temperature and humidity after remove from the test chamber.**

**Note3: The packing have to including into the vibration testing.**

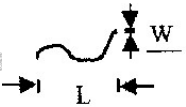

### 13. Inspection specification

NO	Item	Criterion	AQL												
01	Electrical Testing	1.1 Missing vertical, horizontal segment, segment contrast defect. 1.2 Missing character, dot or icon. 1.3 Display malfunction. 1.4 No function or no display. 1.5 Current consumption exceeds product specifications. 1.6 LCD viewing angle defect. 1.7 Mixed product types. 1.8 Contrast defect.	0.65												
02	Black or white spots on LCD (display only)	2.1 White and black spots on display $\leq 0.25\text{mm}$ , no more than three white or black spots present. 2.2 Densely spaced: No more than two spots or lines within 3mm	2.5												
03	LCD black spots, white spots, contamination (non-display)	3.1 Round type : As following drawing $\Phi = (x + y) / 2$	2.5												
		3.2 Line type : (As following drawing)  <table border="1"> <thead> <tr> <th>Length</th> <th>Width</th> <th>Acceptable QTY</th> </tr> </thead> <tbody> <tr> <td>---</td> <td><math>W \leq 0.02</math></td> <td>Accept no dense</td> </tr> <tr> <td><math>L \leq 3.0</math></td> <td><math>0.02 &lt; W \leq 0.03</math></td> <td rowspan="2">2</td> </tr> <tr> <td><math>L \leq 2.5</math></td> <td><math>0.03 &lt; W \leq 0.05</math></td> </tr> <tr> <td>---</td> <td><math>0.05 &lt; W</math></td> <td>As round type</td> </tr> </tbody> </table>	Length	Width	Acceptable QTY	---	$W \leq 0.02$	Accept no dense	$L \leq 3.0$	$0.02 < W \leq 0.03$	2	$L \leq 2.5$	$0.03 < W \leq 0.05$	---	$0.05 < W$
Length	Width	Acceptable QTY													
---	$W \leq 0.02$	Accept no dense													
$L \leq 3.0$	$0.02 < W \leq 0.03$	2													
$L \leq 2.5$	$0.03 < W \leq 0.05$														
---	$0.05 < W$	As round type													
04	Polarizer bubbles	If bubbles are visible, judge using black spot specifications, not easy to find, must check in specify direction. <table border="1"> <thead> <tr> <th>Size <math>\Phi</math></th> <th>Acceptable QTY</th> </tr> </thead> <tbody> <tr> <td><math>\Phi \leq 0.20</math></td> <td>Accept no dense</td> </tr> <tr> <td><math>0.20 &lt; \Phi \leq 0.50</math></td> <td>3</td> </tr> <tr> <td><math>0.50 &lt; \Phi \leq 1.00</math></td> <td>2</td> </tr> <tr> <td><math>1.00 &lt; \Phi</math></td> <td>0</td> </tr> <tr> <td>Total QTY</td> <td>3</td> </tr> </tbody> </table>	Size $\Phi$	Acceptable QTY	$\Phi \leq 0.20$	Accept no dense	$0.20 < \Phi \leq 0.50$	3	$0.50 < \Phi \leq 1.00$	2	$1.00 < \Phi$	0	Total QTY	3	2.5
Size $\Phi$	Acceptable QTY														
$\Phi \leq 0.20$	Accept no dense														
$0.20 < \Phi \leq 0.50$	3														
$0.50 < \Phi \leq 1.00$	2														
$1.00 < \Phi$	0														
Total QTY	3														

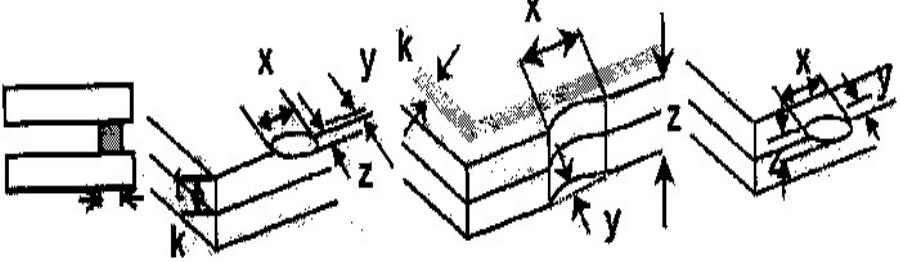
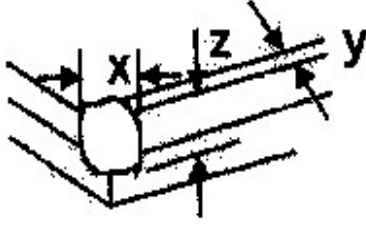
NO	Item	Criterion	AQL																		
05	Scratches	Follow NO.3 LCD black spots, white spots, contamination																			
06	Chipped glass	<p>Symbols Define:            x: Chip length      y: Chip width      z: Chip thickness            k: Seal width      t: Glass thickness      a: LCD side length            L: Electrode pad length:</p> <p>6.1 General glass chip :            6.1.1 Chip on panel surface and crack between panels:</p>  <table border="1" data-bbox="443 1077 1358 1234"> <thead> <tr> <th>z: Chip thickness</th> <th>y: Chip width</th> <th>x: Chip length</th> </tr> </thead> <tbody> <tr> <td><math>Z \leq 1/2t</math></td> <td>Not over viewing area</td> <td><math>x \leq 1/8a</math></td> </tr> <tr> <td><math>1/2t &lt; z \leq 2t</math></td> <td>Not exceed 1/3k</td> <td><math>x \leq 1/8a</math></td> </tr> </tbody> </table> <p>⊙ If there are 2 or more chips, x is total length of each chip.</p> <p>6.1.2 Corner crack:</p>  <table border="1" data-bbox="443 1615 1358 1771"> <thead> <tr> <th>z: Chip thickness</th> <th>y: Chip width</th> <th>x: Chip length</th> </tr> </thead> <tbody> <tr> <td><math>Z \leq 1/2t</math></td> <td>Not over viewing area</td> <td><math>x \leq 1/8a</math></td> </tr> <tr> <td><math>1/2t &lt; z \leq 2t</math></td> <td>Not exceed 1/3k</td> <td><math>x \leq 1/8a</math></td> </tr> </tbody> </table> <p>⊙ If there are 2 or more chips, x is the total length of each chip.</p>	z: Chip thickness	y: Chip width	x: Chip length	$Z \leq 1/2t$	Not over viewing area	$x \leq 1/8a$	$1/2t < z \leq 2t$	Not exceed 1/3k	$x \leq 1/8a$	z: Chip thickness	y: Chip width	x: Chip length	$Z \leq 1/2t$	Not over viewing area	$x \leq 1/8a$	$1/2t < z \leq 2t$	Not exceed 1/3k	$x \leq 1/8a$	2.5
z: Chip thickness	y: Chip width	x: Chip length																			
$Z \leq 1/2t$	Not over viewing area	$x \leq 1/8a$																			
$1/2t < z \leq 2t$	Not exceed 1/3k	$x \leq 1/8a$																			
z: Chip thickness	y: Chip width	x: Chip length																			
$Z \leq 1/2t$	Not over viewing area	$x \leq 1/8a$																			
$1/2t < z \leq 2t$	Not exceed 1/3k	$x \leq 1/8a$																			

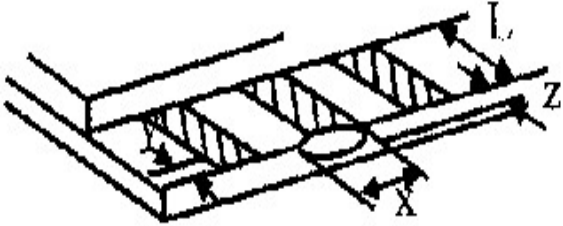
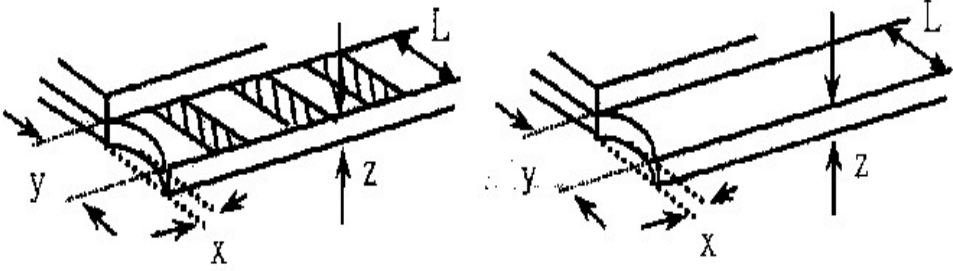
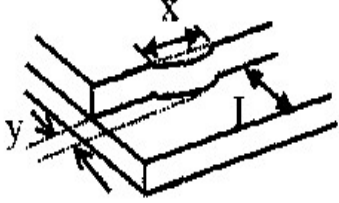
NO	Item	Criterion	AQL						
06	Glass crack	<p>Symbols :</p> <p>x: Chip length      y: Chip width      z: Chip thickness            k: Seal width      t: Glass thickness      a: LCD side length            L: Electrode pad length</p> <p>6.2 Protrusion over terminal :</p> <p>6.2.1 Chip on electrode pad :</p>  <table border="1" data-bbox="336 898 1262 981"> <tr> <td>y: Chip width</td> <td>x: Chip length</td> <td>z: Chip thickness</td> </tr> <tr> <td><math>y \leq 0.5\text{mm}</math></td> <td><math>x \leq 1/8a</math></td> <td><math>0 &lt; z \leq t</math></td> </tr> </table>	y: Chip width	x: Chip length	z: Chip thickness	$y \leq 0.5\text{mm}$	$x \leq 1/8a$	$0 < z \leq t$	2.5
		y: Chip width	x: Chip length	z: Chip thickness					
		$y \leq 0.5\text{mm}$	$x \leq 1/8a$	$0 < z \leq t$					
		<p>6.2.2 Non-conductive portion:</p>  <table border="1" data-bbox="411 1308 1262 1429"> <tr> <td>y: Chip width</td> <td>x: Chip length</td> <td>z: Chip thickness</td> </tr> <tr> <td><math>y \leq L</math></td> <td><math>x \leq 1/8a</math></td> <td><math>0 &lt; z \leq t</math></td> </tr> </table>	y: Chip width	x: Chip length	z: Chip thickness	$y \leq L$	$x \leq 1/8a$	$0 < z \leq t$	
y: Chip width	x: Chip length	z: Chip thickness							
$y \leq L$	$x \leq 1/8a$	$0 < z \leq t$							
<p>⊙ If the chipped area touches the ITO terminal, over 2/3 of the ITO must remain and be inspected according to electrode terminal specifications.</p> <p>⊙ If the product will be heat sealed by the customer, the alignment mark not be damaged.</p>									
<p>6.2.3 Substrate protuberance and internal crack.</p>  <table border="1" data-bbox="746 1671 1262 1753"> <tr> <td>y: width</td> <td>x: length</td> </tr> <tr> <td><math>y \leq 1/3L</math></td> <td><math>x \leq a</math></td> </tr> </table>	y: width	x: length	$y \leq 1/3L$	$x \leq a$					
y: width	x: length								
$y \leq 1/3L$	$x \leq a$								

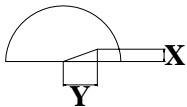
NO	Item	Criterion	AQL
07	Cracked glass	The LCD with extensive crack is not acceptable.	2.5
08	Backlight elements	8.1 Illumination source flickers when lit. 8.2 Spots or scratched that appear when lit must be judged. Using LCD spot, lines and contamination standards. 8.3 Backlight doesn't light or color wrong.	0.65 2.5 0.65
09	Bezel	9.1 Bezel may not have rust, be deformed or have fingerprints, stains or other contamination. 9.2 Bezel must comply with job specifications.	2.5 0.65
10	PCB · COB	10.1 COB seal may not have pinholes larger than 0.2mm or contamination. 10.2 COB seal surface may not have pinholes through to the IC. 10.3 The height of the COB should not exceed the height indicated in the assembly diagram. 10.4 There may not be more than 2mm of sealant outside the seal area on the PCB. And there should be no more than three places. 10.5 No oxidation or contamination PCB terminals. 10.6 Parts on PCB must be the same as on the production characteristic chart. There should be no wrong parts, missing parts or excess parts. 10.7 The jumper on the PCB should conform to the product characteristic chart. 10.8 If solder gets on bezel tab pads, LED pad, zebra pad or screw hold pad, make sure it is smoothed down. 10.9 The Scraping testing standard for Copper Coating of PCB  $X * Y \leq 2\text{mm}^2$	2.5 2.5 0.65 2.5 2.5 0.65 0.65 2.5 2.5
11	Soldering	11.1 No un-melted solder paste may be present on the PCB. 11.2 No cold solder joints, missing solder connections, oxidation or icicle. 11.3 No residue or solder balls on PCB. 11.4 No short circuits in components on PCB.	2.5 2.5 2.5 0.65

NO	Item	Criterion	AQL
12	General appearance	12.1 No oxidation, contamination, curves or, bends on interface Pin (OLB) of TCP.	2.5
		12.2 No cracks on interface pin (OLB) of TCP.	0.65
		12.3 No contamination, solder residue or solder balls on product.	2.5
		12.4 The IC on the TCP may not be damaged, circuits.	2.5
		12.5 The uppermost edge of the protective strip on the interface pin must be present or look as if it causes the interface pin to sever.	2.5
		12.6 The residual rosin or tin oil of soldering (component or chip component) is not burned into brown or black color.	2.5
		12.7 Sealant on top of the ITO circuit has not hardened.	0.65
		12.8 Pin type must match type in specification sheet.	0.65
		12.9 LCD pin loose or missing pins.	0.65
		12.10 Product packaging must the same as specified on packaging specification sheet.	0.65
		12.11 Product dimension and structure must conform to product specification sheet.	0.65

## 14. Precautions in use of LCD Modules

1. Avoid applying excessive shocks to the module or making any alterations or modifications to it.
2. Don't make extra holes on the printed circuit board, modify its shape or change the components of LCD module.
3. Don't disassemble the LCM.
4. Don't operate it above the absolute maximum rating.
5. Don't drop, bend or twist LCM.
6. Soldering: only to the I/O terminals.
7. Storage: please storage in anti-static electricity container and clean environment.
8. Raystar have the right to change the passive components  
(Resistors, capacitors and other passive components will have different appearance and color caused by the different supplier.)
9. Raystar have the right to change the PCB Rev.

## 15. Material List of Components for RoHs

1. RAYSTAR Optronics Co., Ltd. hereby declares that all of or part of products, including, but not limited to, the LCM, accessories or packages, manufactured and/or delivered to your company (including your subsidiaries and affiliated company) directly or indirectly by our company (including our subsidiaries or affiliated companies) do not intentionally contain any of the substances listed in all applicable EU directives and regulations, including the following substances.

Exhibit A : The Harmful Material List

Material	(Cd)	(Pb)	(Hg)	(Cr6+)	PBBs	PBDEs
Limited Value	100 ppm	1000 ppm	1000 ppm	1000 ppm	1000 ppm	1000 ppm
Above limited value is set up according to RoHS.						

2. Process for RoHS requirement :

- (1) Use the Sn/Ag/Cu soldering surface ; the surface of Pb-free solder is rougher than we used before.
- (2) Heat-resistance temp. :  
 Reflow : 250°C, 30 seconds Max. ;  
 Connector soldering wave or hand soldering : 320°C, 10 seconds max.
- (3) Temp. curve of reflow, max. Temp. : 235±5°C ;  
 Recommended customer's soldering temp. of connector : 280°C, 3 seconds.

## 16. Recommendable storage

1. Place the panel or module in the temperature 25°C±5°C and the humidity below 65% RH
2. Do not place the module near organics solvents or corrosive gases.
3. Do not crush, shake, or jolt the module

**LCM Sample Estimate Feedback Sheet**

Module Number : \_\_\_\_\_

**1 、 Panel Specification :**

1. Panel Type :	<input type="checkbox"/> Pass	<input type="checkbox"/> NG , _____
2. View Direction :	<input type="checkbox"/> Pass	<input type="checkbox"/> NG , _____
3. Numbers of Dots :	<input type="checkbox"/> Pass	<input type="checkbox"/> NG , _____
4. View Area :	<input type="checkbox"/> Pass	<input type="checkbox"/> NG , _____
5. Active Area :	<input type="checkbox"/> Pass	<input type="checkbox"/> NG , _____
6. Operating Temperature :	<input type="checkbox"/> Pass	<input type="checkbox"/> NG , _____
7. Storage Temperature :	<input type="checkbox"/> Pass	<input type="checkbox"/> NG , _____
8. Others :	_____	

**2 、 Mechanical Specification :**

1. PCB Size :	<input type="checkbox"/> Pass	<input type="checkbox"/> NG , _____
2. Frame Size :	<input type="checkbox"/> Pass	<input type="checkbox"/> NG , _____
3. Material of Frame :	<input type="checkbox"/> Pass	<input type="checkbox"/> NG , _____
4. Connector Position :	<input type="checkbox"/> Pass	<input type="checkbox"/> NG , _____
5. Fix Hole Position :	<input type="checkbox"/> Pass	<input type="checkbox"/> NG , _____
6. Backlight Position :	<input type="checkbox"/> Pass	<input type="checkbox"/> NG , _____
7. Thickness of PCB :	<input type="checkbox"/> Pass	<input type="checkbox"/> NG , _____
8. Height of Frame to PCB :	<input type="checkbox"/> Pass	<input type="checkbox"/> NG , _____
9. Height of Module :	<input type="checkbox"/> Pass	<input type="checkbox"/> NG , _____
10. Others :	<input type="checkbox"/> Pass	<input type="checkbox"/> NG , _____

**3 、 Relative Hole Size :**

1. Pitch of Connector :	<input type="checkbox"/> Pass	<input type="checkbox"/> NG , _____
2. Hole size of Connector :	<input type="checkbox"/> Pass	<input type="checkbox"/> NG , _____
3. Mounting Hole size :	<input type="checkbox"/> Pass	<input type="checkbox"/> NG , _____
4. Mounting Hole Type :	<input type="checkbox"/> Pass	<input type="checkbox"/> NG , _____
5. Others :	<input type="checkbox"/> Pass	<input type="checkbox"/> NG , _____

**4 、 Backlight Specification :**

1. B/L Type :	<input type="checkbox"/> Pass	<input type="checkbox"/> NG , _____
2. B/L Color :	<input type="checkbox"/> Pass	<input type="checkbox"/> NG , _____
3. B/L Driving Voltage (Reference for LED Type) :	<input type="checkbox"/> Pass	<input type="checkbox"/> NG , _____
4. B/L Driving Current :	<input type="checkbox"/> Pass	<input type="checkbox"/> NG , _____
5. Brightness of B/L :	<input type="checkbox"/> Pass	<input type="checkbox"/> NG , _____
6. B/L Solder Method :	<input type="checkbox"/> Pass	<input type="checkbox"/> NG , _____
7. Others :	<input type="checkbox"/> Pass	<input type="checkbox"/> NG , _____

>> Go to page 2 <<

Module Number : \_\_\_\_\_

**5 、 Electronic Characteristics of Module :**

1.Input Voltage :	<input type="checkbox"/> Pass	<input type="checkbox"/> NG , _____
2.Supply Current :	<input type="checkbox"/> Pass	<input type="checkbox"/> NG , _____
3.Driving Voltage for LCD :	<input type="checkbox"/> Pass	<input type="checkbox"/> NG , _____
4.Contrast for LCD :	<input type="checkbox"/> Pass	<input type="checkbox"/> NG , _____
5.B/L Driving Method :	<input type="checkbox"/> Pass	<input type="checkbox"/> NG , _____
6.Negative Voltage Output :	<input type="checkbox"/> Pass	<input type="checkbox"/> NG , _____
7.Interface Function :	<input type="checkbox"/> Pass	<input type="checkbox"/> NG , _____
8.LCD Uniformity :	<input type="checkbox"/> Pass	<input type="checkbox"/> NG , _____
9.ESD test :	<input type="checkbox"/> Pass	<input type="checkbox"/> NG , _____
10.Others :	<input type="checkbox"/> Pass	<input type="checkbox"/> NG , _____

**6 、 Summary :**

Sales signature : \_\_\_\_\_

Customer Signature : \_\_\_\_\_

Date :    /    /