

40V 150mA Low Power LDO

Features

- Low Power Consumption: 2μA
- Low Voltage Drops: 600mV @ 100mA
- Low Temperature Coefficient
- Fixed Output Voltages: 1.8V, 2.5V, 2.7V, 3.0V, 3.3V, 3.6V, 4.0V, 4.4V, 5.0V
- Thermal Shutdown Protection
- High Ripple Rejection: 65dB @ 100Hz
- High Input Voltage (Up to 40V)
- Output current @ $V_{IN}-V_{OUT}=2V$ (Up to 150mA)
- Output Voltage Accuracy: $\pm 2\%$ at 25°C
- SOT23-3/SOT89-3 Package

Applications

- Power Meter
- Multicell Battery Powered Equipment
- Communication equipment
- Smoke Detector
- Audio/Video Equipment
- LED Driver

General Description

The RY6313 series is a set of high voltage, high accuracy, low quiescent current, low dropout and low power consumption linear regulators. They are designed primarily as CMOS technology. They allow input voltages as fixed voltage regulators. These devices can be high as 40V. They are available with several fixed used with external components to obtain variable output voltages ranging from 1.8V to 5.0V. The RY6313 series are available in SOT23-3 and SOT89-3 package.

Typical Application Circuit

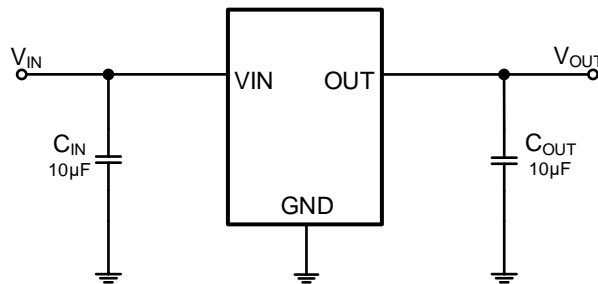

Typical Application Circuit

40V 150mA Low Power LDO

Pin Description

Pin Configuration

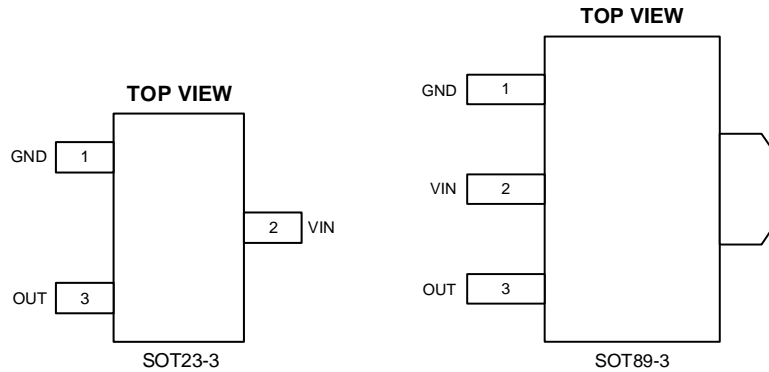

Pin Description

Pin No.		Function
SOT23-3	SOT89-3	
1	1	Ground pin.
2	2	Input voltage pin for the regulator.
3	3	Output voltage pin for the regulator.

Order Information

RY6313-①②③④

Designator	Symbol	Description	Package	T/R Qty
①②	Integer	Output Voltage		
③	M	SOT23-3		
	P	SOT89-3		
④	R	RoHS / Pb Free		
Part No.	Model	Description	Package	T/R Qty
70609110	RY6313-18HMR	RY6313-18HMR LDO, 1.8V, SOT23-3	SOT23-3	3000PCS
70609111	RY6313-25HMR	RY6313-25HMR LDO, 2.5V, SOT23-3	SOT23-3	3000PCS
70609112	RY6313-27HMR	RY6313-27HMR LDO, 2.7V, SOT23-3	SOT23-3	3000PCS
70609113	RY6313-28HMR	RY6313-27HMR LDO, 2.8V, SOT23-3	SOT23-3	3000PCS
70609114	RY6313-30HMR	RY6313-30HMR LDO, 3.0V, SOT23-3	SOT23-3	3000PCS
70609115	RY6313-33HMR	RY6313-33HMR LDO, 3.3V, SOT23-3	SOT23-3	3000PCS
70609116	RY6313-36HMR	RY6313-36HMR LDO, 3.6V, SOT23-3	SOT23-3	3000PCS

40V 150mA Low Power LDO

70609117	RY6313-40HMR	RY6313-40HMR LDO, 4.0V, SOT23-3	SOT23-3	3000PCS
70609118	RY6313-44HMR	RY6313-44HMR LDO, 4.4V, SOT23-3	SOT23-3	3000PCS
70609119	RY6313-50HMR	RY6313-50HMR LDO, 5.0V, SOT23-3	SOT23-3	3000PCS
70609120	RY6313-18HPR	RY6313-18HPR LDO, 1.8V, SOT89-3	SOT89-3	1000PCS
70609121	RY6313-25HPR	RY6313-25HPR LDO, 2.5V, SOT89-3	SOT89-3	1000PCS
70609122	RY6313-27HPR	RY6313-27HPR LDO, 2.7V, SOT89-3	SOT89-3	1000PCS
70609123	RY6313-28HPR	RY6313-27HPR LDO, 2.8V, SOT89-3	SOT89-3	1000PCS
70609124	RY6313-30HPR	RY6313-30HPR LDO, 3.0V, SOT89-3	SOT89-3	1000PCS
70609125	RY6313-33HPR	RY6313-33HPR LDO, 3.3V, SOT89-3	SOT89-3	1000PCS
70609126	RY6313-35HPR	RY6313-35HPR LDO, 3.5V, SOT89-3	SOT89-3	1000PCS
70609127	RY6313-36HPR	RY6313-36HPR LDO, 3.6V, SOT89-3	SOT89-3	1000PCS
70609128	RY6313-40HPR	RY6313-40HPR LDO, 4.0V, SOT89-3	SOT89-3	1000PCS
70609129	RY6313-44HPR	RY6313-44HPR LDO, 4.4V, SOT89-3	SOT89-3	1000PCS
70609130	RY6313-50HPR	RY6313-50HPR LDO, 5.0V, SOT89-3	SOT89-3	1000PCS

Mark Rule

Voltage (V)	SOT23-3	SOT89-3
1.8V	7318 <u>YL</u>	7P18 <u>YL</u>
2.5V	7325 <u>YL</u>	7P25 <u>YL</u>
2.7V	7327 <u>YL</u>	7P27 <u>YL</u>
2.8V	7328 <u>YL</u>	7P28 <u>YL</u>
3.0V	7330 <u>YL</u>	7P30 <u>YL</u>
3.3V	7333 <u>YL</u>	7P33 <u>YL</u>
3.5V	7335 <u>YL</u>	7P35 <u>YL</u>
3.6V	7336 <u>YL</u>	7P36 <u>YL</u>
4.0V	7340 <u>YL</u>	7P40 <u>YL</u>
4.4V	7344 <u>YL</u>	7P44 <u>YL</u>
5.0V	7350 <u>YL</u>	7P50 <u>YL</u>

40V 150mA Low Power LDO

Functional Block Diagram

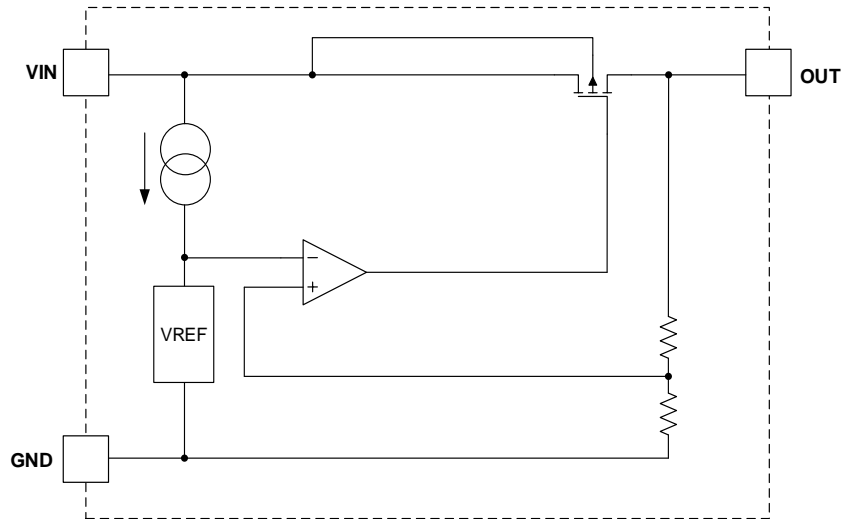

Functional Block Diagram

Specifications

Absolute Maximum Ratings ⁽¹⁾ ⁽²⁾

Item	Min	Max	Unit	
V _{IN} voltage	4.5	40	V	
V _{OUT} voltage	1.5	6	V	
Output Current ⁽³⁾	200		mA	
Power Dissipation	SOT23-3	0.5	0.7	W
	SOT89-3	0.8	1.0	
Operating Ambient Temperature	-40	85	°C	
Maximum junction temperature		150	°C	
Storage temperature, T _{stg}	-50	85	°C	
Lead Temperature (Soldering, 10sec.)		260	°C	

Note (1): Exceeding these ratings may damage the device.

Note (2): The device is not guaranteed to function outside of its operating conditions.

Note (3): $I_{OUT(MAX)} = P_D / (V_{IN} - V_{OUT})$.

40V 150mA Low Power LDO

Recommended Operating Conditions ⁽¹⁾

Item	Min	Max	Unit
Operating junction temperature ⁽¹⁾	-40	125	°C
Operating temperature range	-40	85	°C
Input voltage V _{IN}	4.75	40	V
Output current ⁽²⁾	0	150	mA
Power Dissipation	Based on the calculation ⁽³⁾		W

Note (1): All limits specified at room temperature (T_A = 25°C) unless otherwise specified. All room temperature limits are 100% production tested. All limits at temperature extremes are ensured through correlation using standard Statistical Quality Control (SQC) methods. All limits are used to calculate Average Outgoing Quality Level (AOQL).

Note (2): V_{IN} - V_{OUT} = 2V.

Note (3): P_D = I_{OUT(MAX)} × (V_{IN} - V_{OUT}).

Thermal Information

Item	Description	SOT23 3 Pin	SOT89 3 Pin	Unit
R _{θJA}	Junction-to-ambient thermal resistance ⁽¹⁾⁽²⁾	208	55	°C/W
R _{θJC(top)}	Junction-to-case (top) thermal resistance	112	88	°C/W
R _{θJB}	Junction-to-board thermal resistance	56	9.6	°C/W
Ψ _{JT}	Junction-to-top characterization parameter	9.2	6.2	°C/W
Ψ _{JB}	Junction-to-board characterization parameter	52	9.7	°C/W
R _{θJC(bot)}	Junction-to-case (bottom) thermal resistance	N/A	7.7	°C/W

Note (1): The package thermal impedance is calculated in accordance to JESD 51-7.

Note (2): Thermal Resistances were simulated on a 4-layer, JEDEC board

40V 150mA Low Power LDO

Electrical Characteristics

The following specifications apply for $V_{IN} = 12V$, $T_A = 25^\circ C$, $C_{IN} = C_{OUT} = 10\mu F$, unless specified otherwise.

Parameter	Symbol	Test Conditions	Min	Typ.	Max	Units
Input Range	V_{IN}	$I_{OUT} = 10mA$	4.75		40	V
Output Range	V_{OUT}	$I_{OUT} = 10mA$	$V_{OUT} \times 0.98$	V_{OUT}	$V_{OUT} \times 1.02$	V
Output Voltage	ΔV_{OUT}	$V_{IN} = 12V, I_{OUT} = 10mA$	4.9	5	5.1	V
			3.234	3.3	3.366	
			2.94	3.0	3.06	
Quiescent Current	I_Q	$V_{IN} = 6V, V_{OUT} = 5V,$ $0mA < I_{OUT} < 1mA$		2		μA
Maximum Output Current	I_{OUT_PK}	$V_{IN} = V_{OUT} + 2V$	150			mA
Dropout Voltage	V_{DROP}	$I_{OUT} = 1mA$		8	12	mV
		$I_{OUT} = 100mA$		600		
Line Regulation	ΔV_{LINE}	$V_{IN} = 7 \sim 40V, V_{OUT} = 5V,$ $I_{OUT} = 1mA$		0.08		%V
Load Regulation	ΔV_{LOAD}	$V_{IN} = 7V, I_{OUT} = 1 \sim 100mA$		30	50	mV
Short Current	I_{SHORT}	V_{OUT} Short to GND with 1Ω (1ms pulse), $V_{IN} = 24V$		180		mA
Power Supply Rejection Rate	PSRR	$V_{IN} = 10V,$ $V_{PP} = 0.5V,$ $I_{OUT} = 1mA$	F = 100Hz	65		dB
			F = 1kHz	60		
			F = 10kHz	55		
Output Noise Voltage	e_{NO}	10Hz to 100kHz, $C_{OUT} = 10\mu F,$ $I_{OUT} = 10mA$		± 100		$\mu VRMS$
Thermal Shutdown Protection	T_{SD}	$V_{IN} = 12V, I_{OUT} = 1mA$		165		$^\circ C$
Temperature Coefficient	$\Delta V_O / \Delta T$			± 0.5		mV/ $^\circ C$

40V 150mA Low Power LDO

Typical Performance Characteristics

Note (1): Typical performance characteristics below based on $T_A = 25^\circ\text{C}$, unless otherwise noted.

Note (2): $V_{OUT}=3.3\text{V}$, $V_{IN}=V_{OUT}+2\text{V}$, $C_{IN}=10\mu\text{F}$, $C_{OUT}=10\mu\text{F}$, package is SOT89-3, unless otherwise noted.

Quiescent Current

$V_{OUT}=3.3\text{V}$

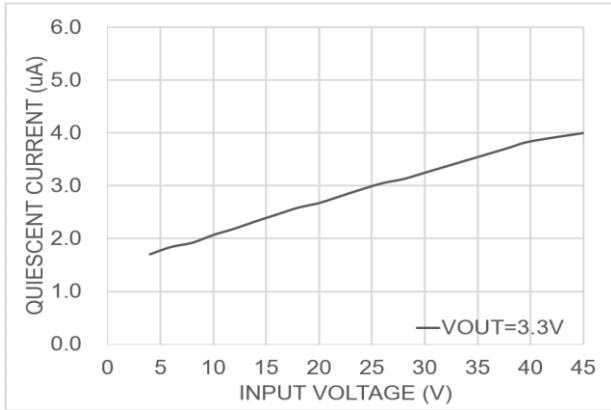

Quiescent Current

$V_{OUT}=5\text{V}$

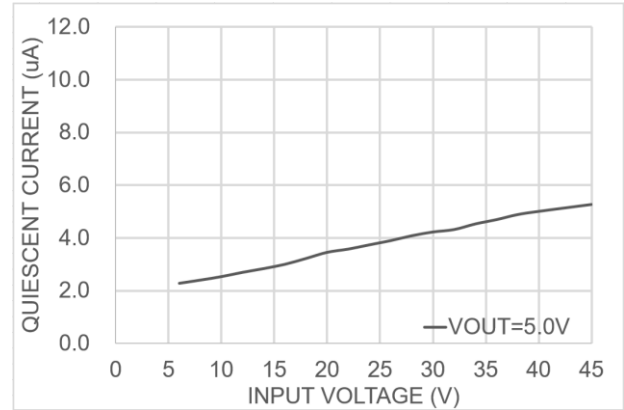

Dropout Voltage vs Output Current

$V_{OUT}=3.3\text{V}$

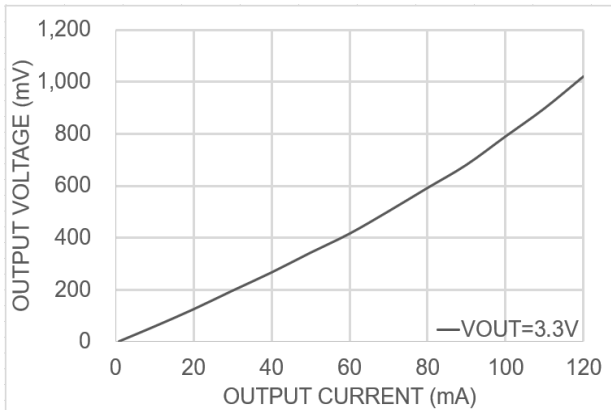

Dropout Voltage vs Output Current

$V_{OUT}=5\text{V}$

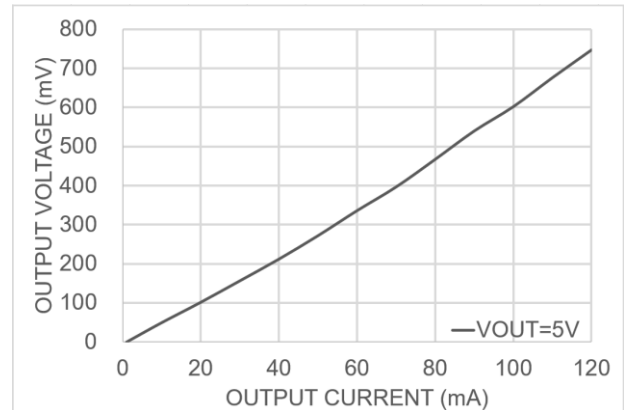

Output Current vs Output Voltage

$V_{OUT}=3.3\text{V}$

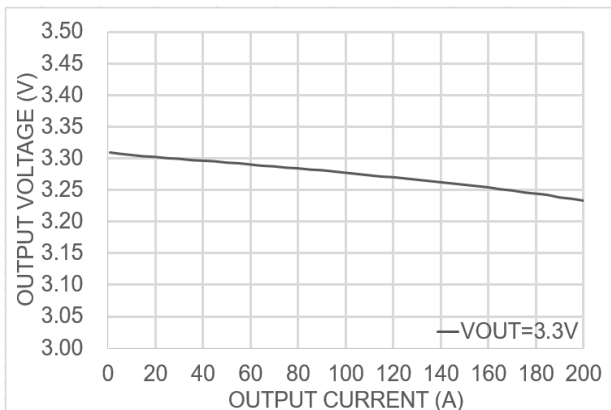

Output Current vs Output Voltage

$V_{OUT}=5\text{V}$

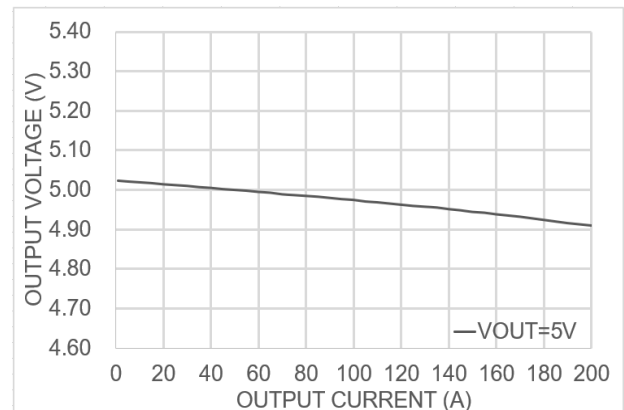

40V 150mA Low Power LDO

Power Supply Rejection Ratio

V_{OUT}=3.3V

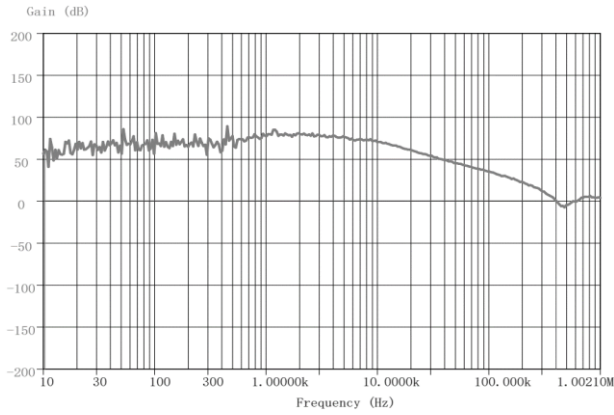

line-Transient Response

V_{OUT}=3.3V

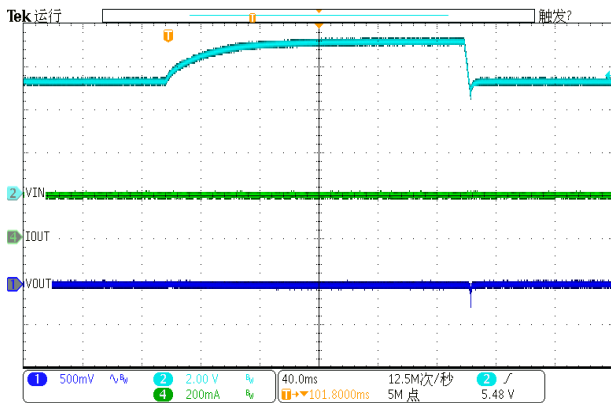

Power Supply Rejection Ratio

V_{OUT}=5V

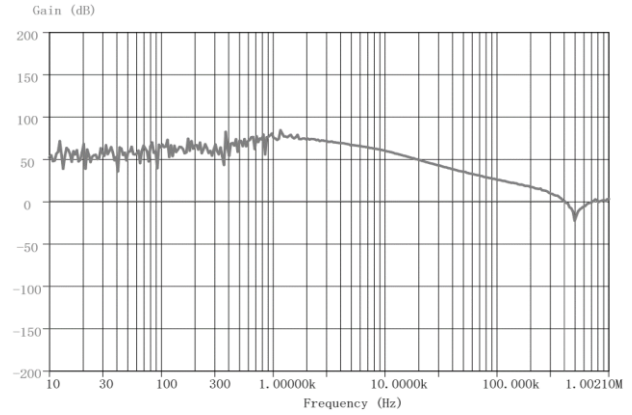

Load-Transient Response

V_{OUT}=3.3V

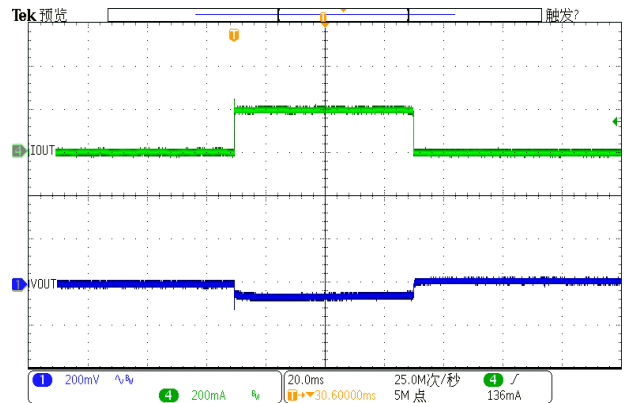

40V 150mA Low Power LDO

Applications Information

Basic Circuits

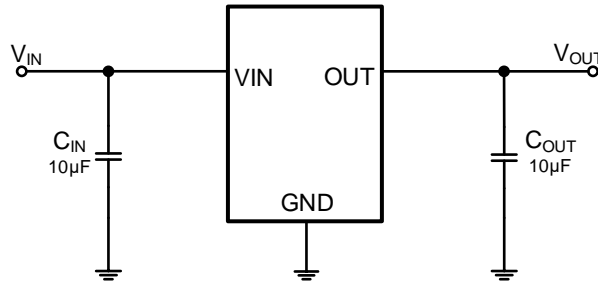

High Output Current Positive Voltage Regulator

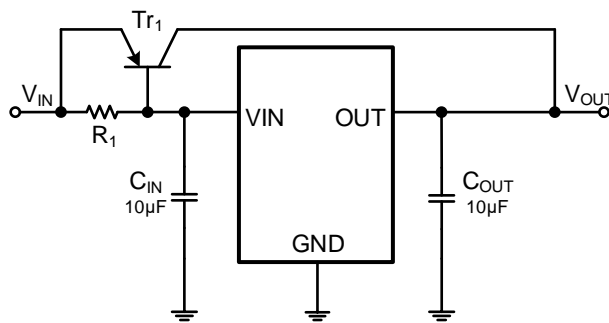

Short-Circuit Protection by Tr1

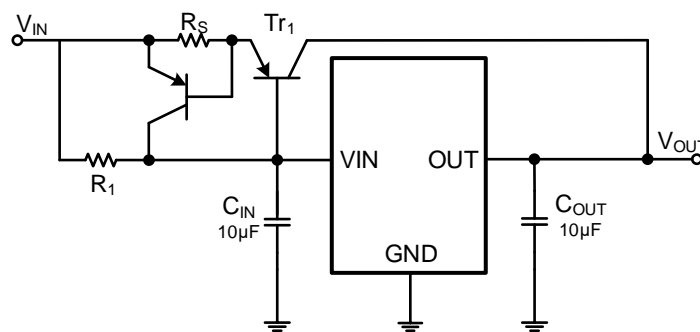

40V 150mA Low Power LDO

Circuit for Increasing Output Voltage

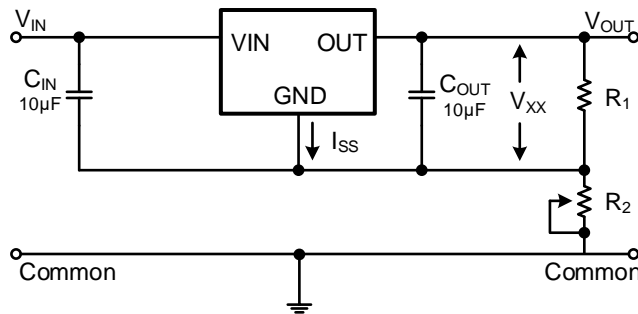

Constant Current Regulator

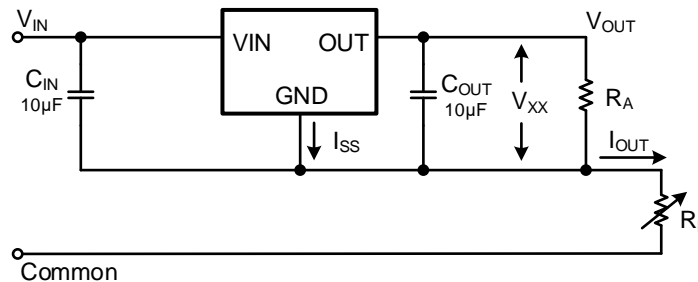

Dual Supply

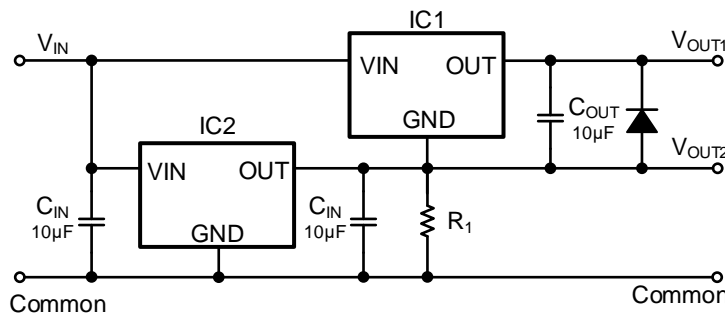

Notes on Use

1. Please use this IC within the stated absolute maximum ratings. The IC is liable to malfunction should the ratings be exceeded.
2. Where wiring impedance is high, operations may become unstable due to noise and/or phase lag depending on output current. Please keep the resistance low between V_{IN} and GND wiring in particular.
3. Please wire the input capacitor (C_{IN}) and the output capacitor (C_{OUT}) as close to the IC as possible.

40V 150mA Low Power LDO

Packaging Information

3-Pin SOT23 Packaging Information

SOT23-3

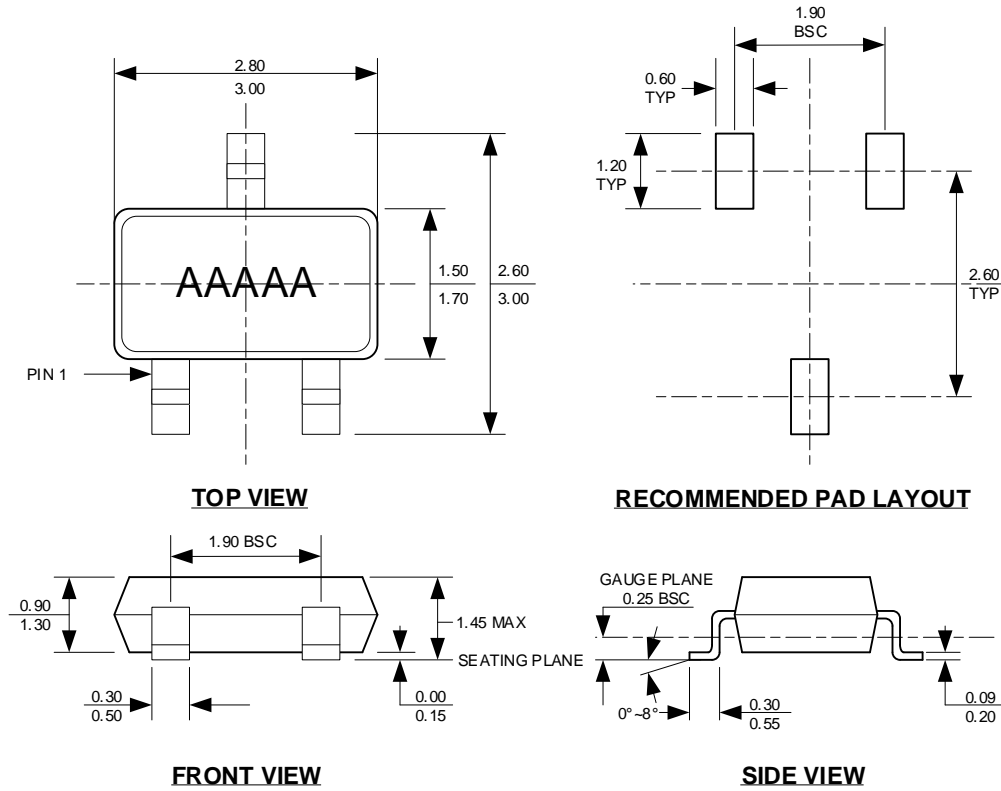

NOTE:

1. CONTROL DIMENSION IS IN INCHES. DIMENSION IN BRACKET IS IN MILLIMETERS.
2. PACKAGE LENGTH DOES NOT INCLUDE MOLD FLASH, PROTRUSIONS OR GATE BURRS.
3. PACKAGE WIDTH DOES NOT INCLUDE INTERLEAD FLASH OR PROTRUSIONS.
4. LEAD COPLANARITY (BOTTOM OF LEADS AFTER FORMING) SHALL BE 0.004" INCHES MAX.
5. DRAWING CONFORMS TO JEDEC MS-012, VARIATION BA.
6. DRAWING IS NOT TO SCALE.

40V 150mA Low Power LDO

3-Pin SOT89 Packaging Information

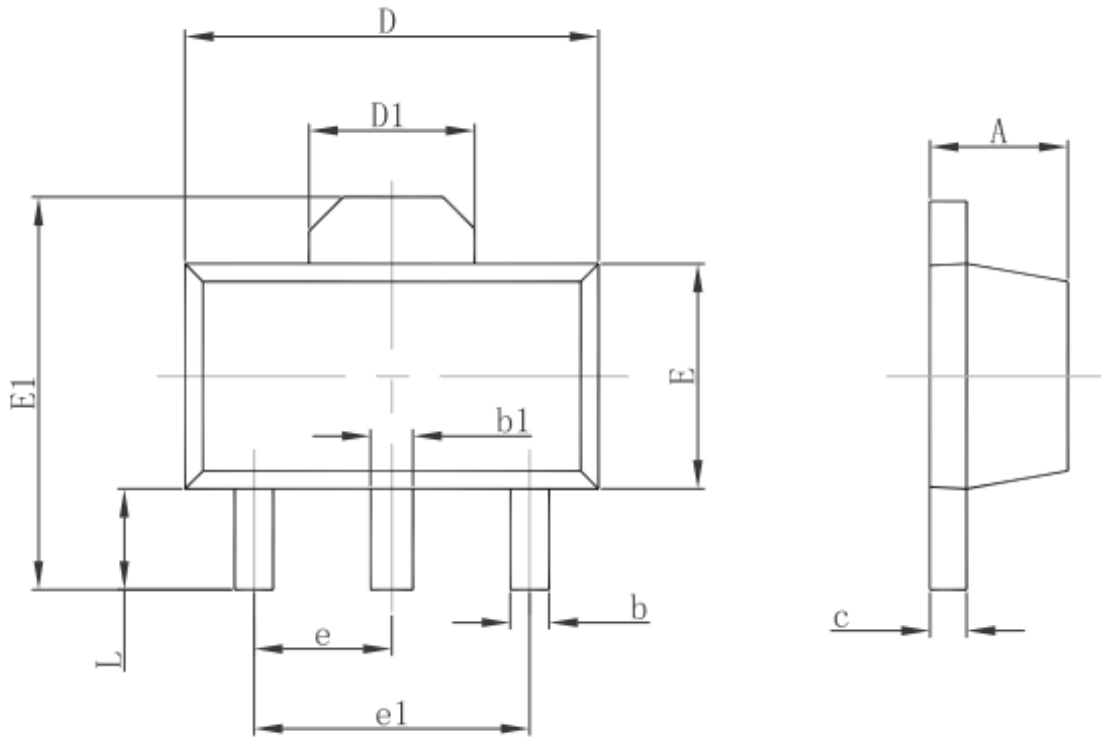

Symbol	Dimensions In Millimeters		Dimensions In Inches	
	Min.	Max.	Min.	Max.
A	1.400	1.600	0.055	0.063
b	0.320	0.520	0.013	0.020
b1	0.400	0.580	0.016	0.023
c	0.350	0.440	0.014	0.017
D	4.400	4.600	0.173	0.181
D1	1.550 REF.		0.061 REF.	
E	2.300	2.600	0.091	0.102
E1	3.940	4.250	0.155	0.167
e	1.500 TYP.		0.060 TYP.	
e1	3.000 TYP.		0.118 TYP.	
L	0.900	1.200	0.035	0.047