

HIGH RIPPLE-REJECTION SOFT-START FUNCTION CMOS VOLTAGE REGULATOR

www.sii-ic.com

© Seiko Instruments Inc., 2012-2014

Rev.1.3_00

The S-1335 Series, developed by using the CMOS technology, is a positive voltage regulator IC of 150 mA output current, which has low dropout voltage, high-accuracy output voltage and soft-start function.

The rising time of output voltage immediately after power-on or after the ON / OFF pin is set to ON is adjustable. A 1.0 μ F small ceramic capacitor can be used. It operates with low current consumption of 36 μ A typ. Furthermore the overcurrent protection circuit prevents the load current from exceeding the capacity of output transistor.

SOT-23-5, SC-82AB and super small HSNT-4 (1010) packages realize high-density mounting.

■ Features

- Output voltage: 1.0 V to 3.6 V, selectable in 0.05 V step
- Input voltage: 1.5 V to 5.5 V
- Output voltage accuracy: $\pm 1.0\%$ (1.0 V to 1.45 V output product: ± 15 mV)
- Dropout voltage: 70 mV typ. (2.8 V output product, $I_{OUT} = 100$ mA)
- Current consumption:
 - During operation: 36 μ A typ., 54 μ A max.
 - During power-off: 0.1 μ A typ., 1.0 μ A max.
- Output current: Possible to output 150 mA ($V_{IN} \geq V_{OUT(S)} + 1.0$ V)^{*1}
- Input and output capacitors: A ceramic capacitor of 1.0 μ F or more can be used.
- Ripple rejection:
 - 70 dB typ. (f = 10 kHz, $V_{OUT(S)} \leq 2.5$ V)
 - 80 dB typ. (f = 1.0 kHz)
- Built-in soft-start circuit:
 - The rising time of output voltage immediately after power-on or after the ON / OFF pin is set to ON is adjustable.
 - The soft-start time of SOT-23-5 can be switched to $t_{SS0} = 0.1$ ms typ. / $t_{SS1} = 1.0$ ms typ. with the SST pin.
 - The soft-start time of SC-82AB is fixed to $t_{SS0} = 0.1$ ms typ.
 - The soft-start time of HSNT-4 (1010) is fixed to either $t_{SS0} = 0.1$ ms typ. or $t_{SS1} = 1.0$ ms typ.
- Built-in overcurrent protection circuit: Limits overcurrent of output transistor.
- Built-in ON / OFF circuit: Ensures long battery life.
- Pull-down resistor is selectable.
- Discharge shunt function is selectable.
- Operation temperature range: $T_a = -40^\circ\text{C}$ to $+85^\circ\text{C}$
- Lead-free (Sn 100%), halogen-free

*1. Attention should be paid to the power dissipation of the package when the output current is large.

■ Applications

- Constant-voltage power supply for digital still camera, TV
- Constant-voltage power supply for battery-powered device
- Constant-voltage power supply for cellular phone
- Constant-voltage power supply for portable equipment

■ Packages

- SOT-23-5
- SC-82AB
- HSNT-4 (1010)

HIGH RIPPLE-REJECTION SOFT-START FUNCTION CMOS VOLTAGE REGULATOR

S-1335 Series

Rev.1.3_00

■ Block Diagrams

1. S-1335 Series A / E type

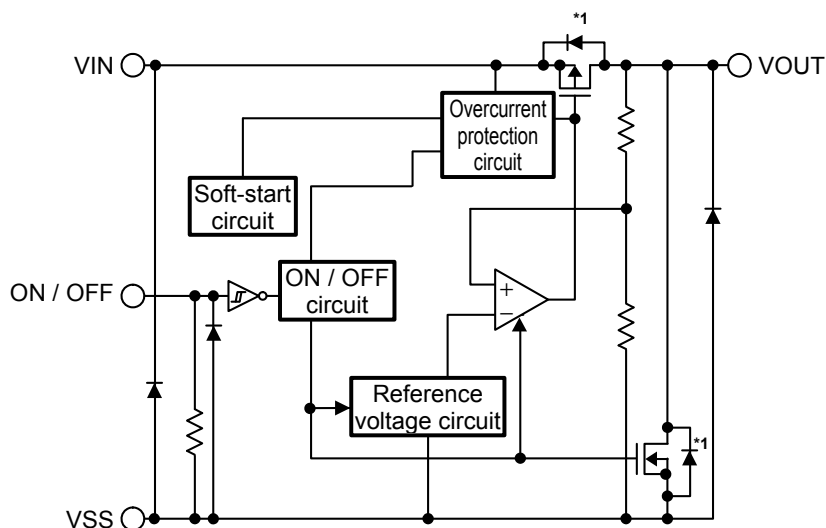

Function	Status
ON / OFF logic	Active "H"
Discharge shunt function	Available
Pull-down resistor	Available
Soft-start time (typ.)	A type: 0.1 ms E type: 1.0 ms

*1. Parasitic diode

Figure 1

2. S-1335 Series B / F type

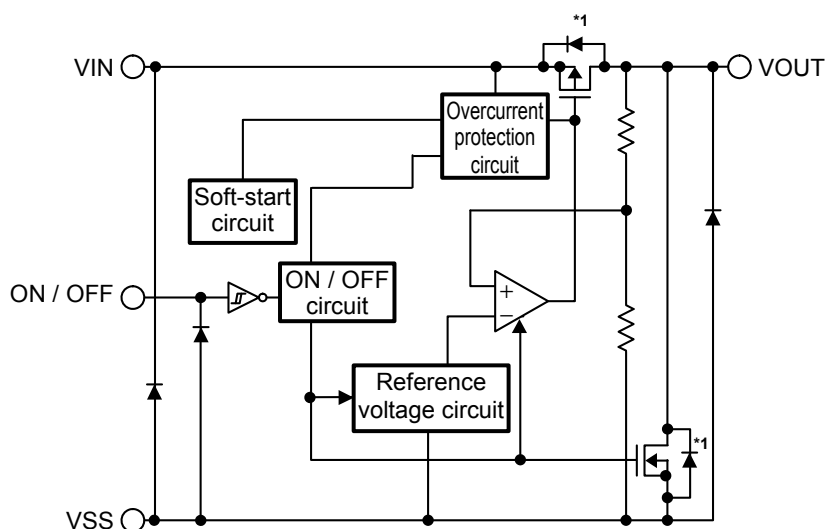

Function	Status
ON / OFF logic	Active "H"
Discharge shunt function	Available
Pull-down resistor	Unavailable
Soft-start time (typ.)	B type: 0.1 ms F type: 1.0 ms

*1. Parasitic diode

Figure 2

HIGH RIPPLE-REJECTION SOFT-START FUNCTION CMOS VOLTAGE REGULATOR

Rev.1.3_00

S-1335 Series

3. S-1335 Series C / G type

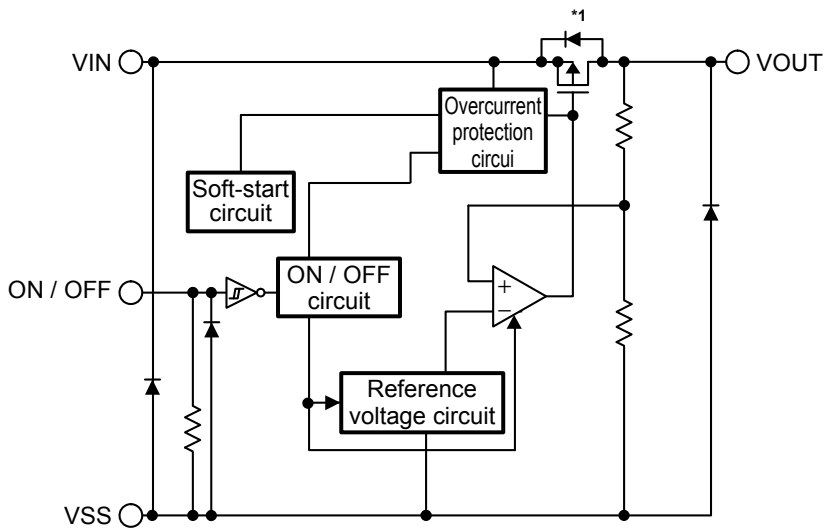

Function	Status
ON / OFF logic	Active "H"
Discharge shunt function	Unavailable
Pull-down resistor	Available
Soft-start time (typ.)	C type: 0.1 ms G type: 1.0 ms

*1. Parasitic diode

Figure 3

4. S-1335 Series D / H type

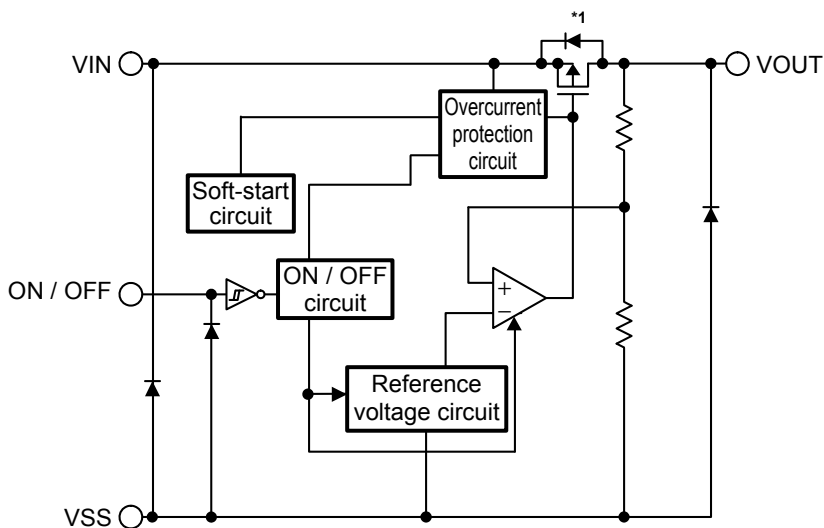

Function	Status
ON / OFF logic	Active "H"
Discharge shunt function	Unavailable
Pull-down resistor	Unavailable
Soft-start time (typ.)	D type: 0.1 ms H type: 1.0 ms

*1. Parasitic diode

Figure 4

5. S-1335 Series J type

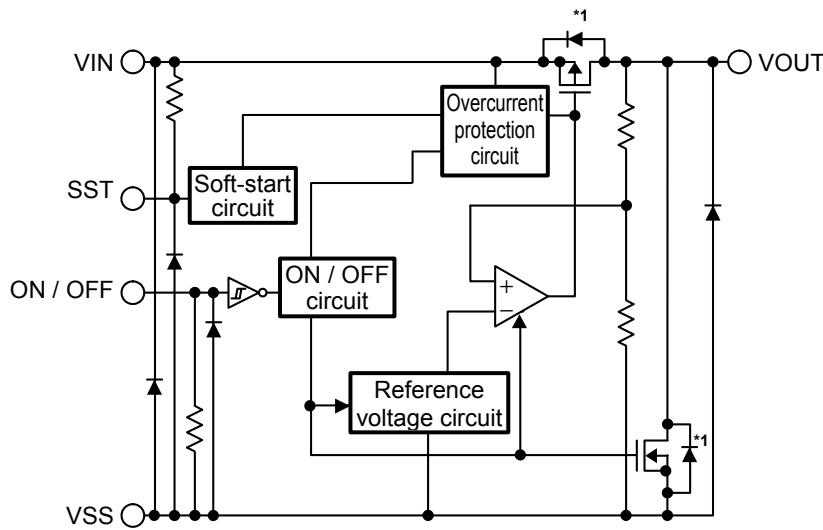

Function	Status
ON / OFF logic	Active "H"
Discharge shunt function	Available
Pull-down resistor	Available
Soft-start time (typ.)	0.1 ms / 1.0 ms (Switchable)

*1. Parasitic diode

Figure 5

6. S-1335 Series K type

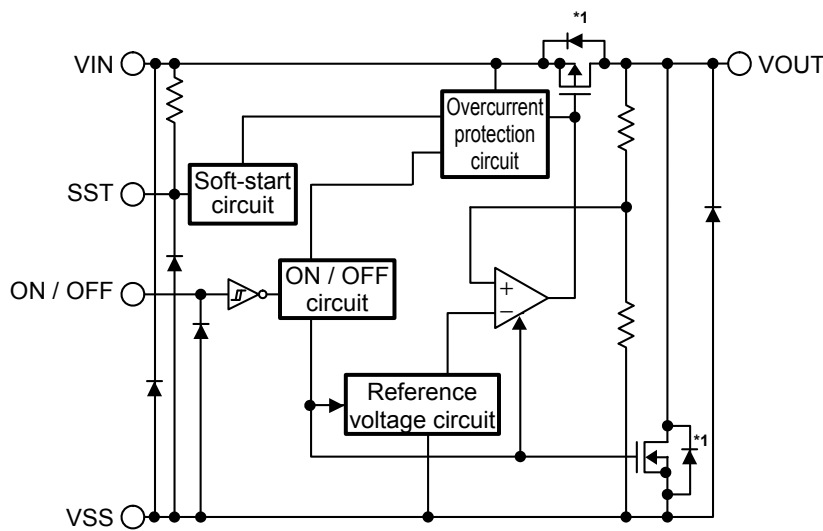

Function	Status
ON / OFF logic	Active "H"
Discharge shunt function	Available
Pull-down resistor	Unavailable
Soft-start time (typ.)	0.1 ms / 1.0 ms (Switchable)

*1. Parasitic diode

Figure 6

HIGH RIPPLE-REJECTION SOFT-START FUNCTION CMOS VOLTAGE REGULATOR

Rev.1.3_00

S-1335 Series

7. S-1335 Series L type

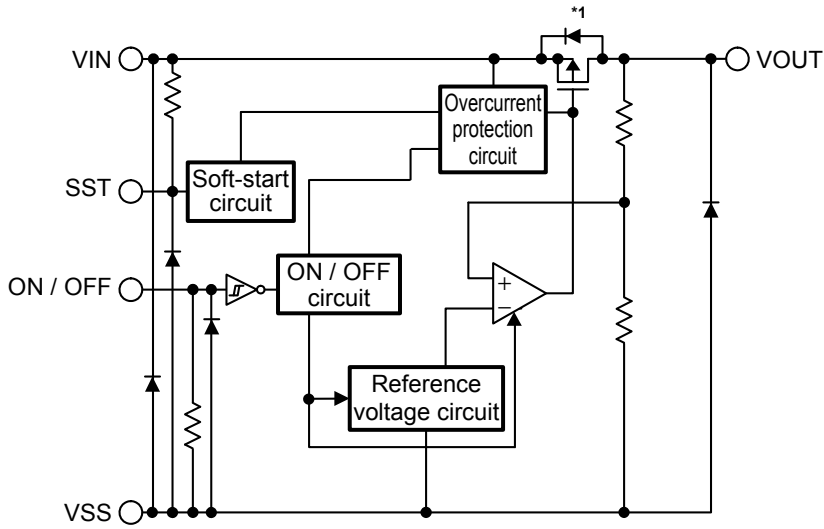

Function	Status
ON / OFF logic	Active "H"
Discharge shunt function	Unavailable
Pull-down resistor	Available
Soft-start time (typ.)	0.1 ms / 1.0 ms (Switchable)

*1. Parasitic diode

Figure 7

8. S-1335 Series M type

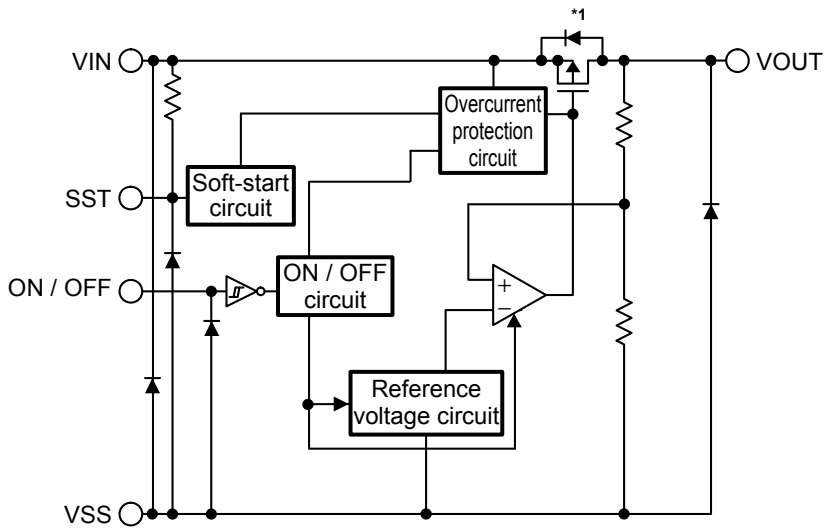

Function	Status
ON / OFF logic	Active "H"
Discharge shunt function	Unavailable
Pull-down resistor	Unavailable
Soft-start time (typ.)	0.1 ms / 1.0 ms (Switchable)

*1. Parasitic diode

Figure 8

■ **Product Name Structure**

Users can select the product type, output voltage, and package type for the S-1335 Series. Refer to "1. **Product name**" regarding the contents of product name, "2. **Function list of product type**" regarding the product type, "3. **Packages**" regarding the package drawings, "4. **Product name list**" regarding details of the product name.

1. **Product name**

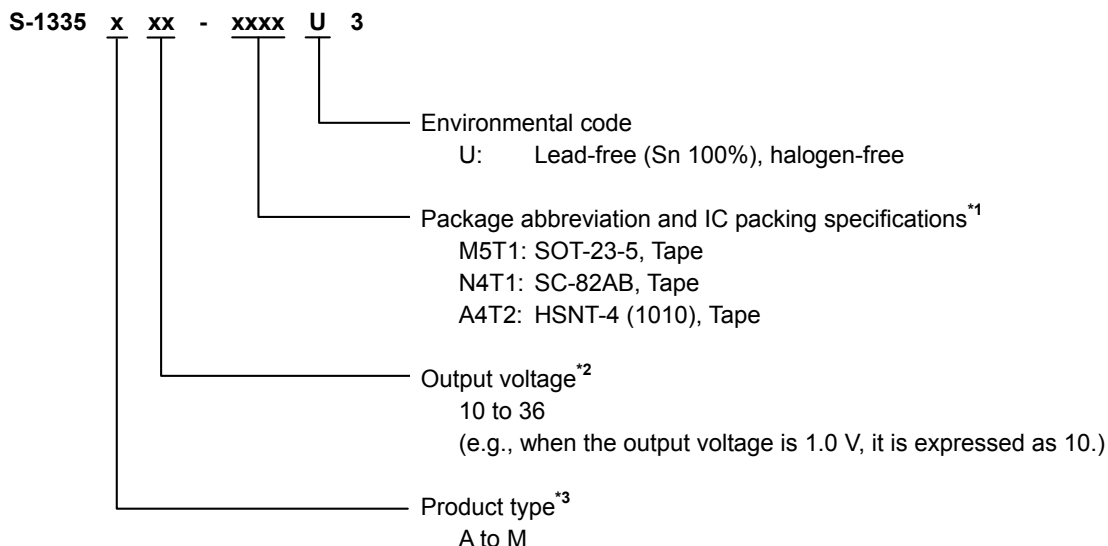

*1. Refer to the tape drawing.

*2. If you request the product which has 0.05 V step, contact our sales office.

*3. Refer to "2. **Function list of product type**".

2. **Function list of product type**

Table 1

Product Type	ON / OFF Logic	Discharge Shunt Function	Pull-down Resistor	Soft-start Time (typ.)	Package
A	Active "H"	Available	Available	0.1 ms	SC-82AB, HSNT-4 (1010)
B	Active "H"	Available	Unavailable	0.1 ms	SC-82AB, HSNT-4 (1010)
C	Active "H"	Unavailable	Available	0.1 ms	SC-82AB, HSNT-4 (1010)
D	Active "H"	Unavailable	Unavailable	0.1 ms	SC-82AB, HSNT-4 (1010)
E	Active "H"	Available	Available	1.0 ms	HSNT-4 (1010)
F	Active "H"	Available	Unavailable	1.0 ms	HSNT-4 (1010)
G	Active "H"	Unavailable	Available	1.0 ms	HSNT-4 (1010)
H	Active "H"	Unavailable	Unavailable	1.0 ms	HSNT-4 (1010)
J	Active "H"	Available	Available	0.1 ms / 1.0 ms (Switchable)	SOT-23-5
K	Active "H"	Available	Unavailable	0.1 ms / 1.0 ms (Switchable)	SOT-23-5
L	Active "H"	Unavailable	Available	0.1 ms / 1.0 ms (Switchable)	SOT-23-5
M	Active "H"	Unavailable	Unavailable	0.1 ms / 1.0 ms (Switchable)	SOT-23-5

HIGH RIPPLE-REJECTION SOFT-START FUNCTION CMOS VOLTAGE REGULATOR

Rev.1.3_00

S-1335 Series

3. Packages

Table 2 Package Drawing Codes

Package Name	Dimension	Tape	Reel	Land
SOT-23-5	MP005-A-P-SD	MP005-A-C-SD	MP005-A-R-SD	-
SC-82AB	NP004-A-P-SD	NP004-A-C-SD NP004-A-C-S1	NP004-A-R-SD	-
HSNT-4 (1010)	PL004-A-P-SD	PL004-A-C-SD	PL004-A-R-SD	PL004-A-L-SD

4. Product name list

4.1 S-1335 Series A type

ON / OFF logic: Active "H"
 Discharge shunt function: Available
 Pull-down resistor: Available
 Soft-start time: 0.1 ms typ.

Table 3

Output Voltage	SC-82AB	HSNT-4 (1010)
1.0 V ± 15 mV	S-1335A10-N4T1U3	S-1335A10-A4T2U3
1.1 V ± 15 mV	S-1335A11-N4T1U3	S-1335A11-A4T2U3
1.2 V ± 15 mV	S-1335A12-N4T1U3	S-1335A12-A4T2U3
1.3 V ± 15 mV	S-1335A13-N4T1U3	S-1335A13-A4T2U3
1.4 V ± 15 mV	S-1335A14-N4T1U3	S-1335A14-A4T2U3
1.5 V ± 1.0%	S-1335A15-N4T1U3	S-1335A15-A4T2U3
1.6 V ± 1.0%	S-1335A16-N4T1U3	S-1335A16-A4T2U3
1.7 V ± 1.0%	S-1335A17-N4T1U3	S-1335A17-A4T2U3
1.8 V ± 1.0%	S-1335A18-N4T1U3	S-1335A18-A4T2U3
1.9 V ± 1.0%	S-1335A19-N4T1U3	S-1335A19-A4T2U3
2.0 V ± 1.0%	S-1335A20-N4T1U3	S-1335A20-A4T2U3
2.1 V ± 1.0%	S-1335A21-N4T1U3	S-1335A21-A4T2U3
2.2 V ± 1.0%	S-1335A22-N4T1U3	S-1335A22-A4T2U3
2.3 V ± 1.0%	S-1335A23-N4T1U3	S-1335A23-A4T2U3
2.4 V ± 1.0%	S-1335A24-N4T1U3	S-1335A24-A4T2U3
2.5 V ± 1.0%	S-1335A25-N4T1U3	S-1335A25-A4T2U3
2.6 V ± 1.0%	S-1335A26-N4T1U3	S-1335A26-A4T2U3
2.7 V ± 1.0%	S-1335A27-N4T1U3	S-1335A27-A4T2U3
2.8 V ± 1.0%	S-1335A28-N4T1U3	S-1335A28-A4T2U3
2.85 V ± 1.0%	S-1335A2J-N4T1U3	S-1335A2J-A4T2U3
2.9 V ± 1.0%	S-1335A29-N4T1U3	S-1335A29-A4T2U3
3.0 V ± 1.0%	S-1335A30-N4T1U3	S-1335A30-A4T2U3
3.1 V ± 1.0%	S-1335A31-N4T1U3	S-1335A31-A4T2U3
3.2 V ± 1.0%	S-1335A32-N4T1U3	S-1335A32-A4T2U3
3.3 V ± 1.0%	S-1335A33-N4T1U3	S-1335A33-A4T2U3
3.4 V ± 1.0%	S-1335A34-N4T1U3	S-1335A34-A4T2U3
3.5 V ± 1.0%	S-1335A35-N4T1U3	S-1335A35-A4T2U3
3.6 V ± 1.0%	S-1335A36-N4T1U3	S-1335A36-A4T2U3

Remark Please contact our sales office for products with specifications other than the above.

4.2 S-1335 Series B type

ON / OFF logic: Active "H"
 Discharge shunt function: Available
 Pull-down resistor: Unavailable
 Soft-start time: 0.1 ms typ.

Table 4

Output Voltage	SC-82AB	HSNT-4 (1010)
1.0 V ± 15 mV	S-1335B10-N4T1U3	S-1335B10-A4T2U3
1.1 V ± 15 mV	S-1335B11-N4T1U3	S-1335B11-A4T2U3
1.2 V ± 15 mV	S-1335B12-N4T1U3	S-1335B12-A4T2U3
1.3 V ± 15 mV	S-1335B13-N4T1U3	S-1335B13-A4T2U3
1.4 V ± 15 mV	S-1335B14-N4T1U3	S-1335B14-A4T2U3
1.5 V ± 1.0%	S-1335B15-N4T1U3	S-1335B15-A4T2U3
1.6 V ± 1.0%	S-1335B16-N4T1U3	S-1335B16-A4T2U3
1.7 V ± 1.0%	S-1335B17-N4T1U3	S-1335B17-A4T2U3
1.8 V ± 1.0%	S-1335B18-N4T1U3	S-1335B18-A4T2U3
1.9 V ± 1.0%	S-1335B19-N4T1U3	S-1335B19-A4T2U3
2.0 V ± 1.0%	S-1335B20-N4T1U3	S-1335B20-A4T2U3
2.1 V ± 1.0%	S-1335B21-N4T1U3	S-1335B21-A4T2U3
2.2 V ± 1.0%	S-1335B22-N4T1U3	S-1335B22-A4T2U3
2.3 V ± 1.0%	S-1335B23-N4T1U3	S-1335B23-A4T2U3
2.4 V ± 1.0%	S-1335B24-N4T1U3	S-1335B24-A4T2U3
2.5 V ± 1.0%	S-1335B25-N4T1U3	S-1335B25-A4T2U3
2.6 V ± 1.0%	S-1335B26-N4T1U3	S-1335B26-A4T2U3
2.7 V ± 1.0%	S-1335B27-N4T1U3	S-1335B27-A4T2U3
2.8 V ± 1.0%	S-1335B28-N4T1U3	S-1335B28-A4T2U3
2.85 V ± 1.0%	S-1335B2J-N4T1U3	S-1335B2J-A4T2U3
2.9 V ± 1.0%	S-1335B29-N4T1U3	S-1335B29-A4T2U3
3.0 V ± 1.0%	S-1335B30-N4T1U3	S-1335B30-A4T2U3
3.1 V ± 1.0%	S-1335B31-N4T1U3	S-1335B31-A4T2U3
3.2 V ± 1.0%	S-1335B32-N4T1U3	S-1335B32-A4T2U3
3.3 V ± 1.0%	S-1335B33-N4T1U3	S-1335B33-A4T2U3
3.4 V ± 1.0%	S-1335B34-N4T1U3	S-1335B34-A4T2U3
3.5 V ± 1.0%	S-1335B35-N4T1U3	S-1335B35-A4T2U3
3.6 V ± 1.0%	S-1335B36-N4T1U3	S-1335B36-A4T2U3

Remark Please contact our sales office for products with specifications other than the above.

4.3 S-1335 Series C type

ON / OFF logic: Active "H"
 Discharge shunt function: Unavailable
 Pull-down resistor: Available
 Soft-start time: 0.1 ms typ.

Table 5

Output Voltage	SC-82AB	HSNT-4 (1010)
1.0 V ± 15 mV	S-1335C10-N4T1U3	S-1335C10-A4T2U3
1.1 V ± 15 mV	S-1335C11-N4T1U3	S-1335C11-A4T2U3
1.2 V ± 15 mV	S-1335C12-N4T1U3	S-1335C12-A4T2U3
1.3 V ± 15 mV	S-1335C13-N4T1U3	S-1335C13-A4T2U3
1.4 V ± 15 mV	S-1335C14-N4T1U3	S-1335C14-A4T2U3
1.5 V ± 1.0%	S-1335C15-N4T1U3	S-1335C15-A4T2U3
1.6 V ± 1.0%	S-1335C16-N4T1U3	S-1335C16-A4T2U3
1.7 V ± 1.0%	S-1335C17-N4T1U3	S-1335C17-A4T2U3
1.8 V ± 1.0%	S-1335C18-N4T1U3	S-1335C18-A4T2U3
1.9 V ± 1.0%	S-1335C19-N4T1U3	S-1335C19-A4T2U3
2.0 V ± 1.0%	S-1335C20-N4T1U3	S-1335C20-A4T2U3
2.1 V ± 1.0%	S-1335C21-N4T1U3	S-1335C21-A4T2U3
2.2 V ± 1.0%	S-1335C22-N4T1U3	S-1335C22-A4T2U3
2.3 V ± 1.0%	S-1335C23-N4T1U3	S-1335C23-A4T2U3
2.4 V ± 1.0%	S-1335C24-N4T1U3	S-1335C24-A4T2U3
2.5 V ± 1.0%	S-1335C25-N4T1U3	S-1335C25-A4T2U3
2.6 V ± 1.0%	S-1335C26-N4T1U3	S-1335C26-A4T2U3
2.7 V ± 1.0%	S-1335C27-N4T1U3	S-1335C27-A4T2U3
2.8 V ± 1.0%	S-1335C28-N4T1U3	S-1335C28-A4T2U3
2.85 V ± 1.0%	S-1335C2J-N4T1U3	S-1335C2J-A4T2U3
2.9 V ± 1.0%	S-1335C29-N4T1U3	S-1335C29-A4T2U3
3.0 V ± 1.0%	S-1335C30-N4T1U3	S-1335C30-A4T2U3
3.1 V ± 1.0%	S-1335C31-N4T1U3	S-1335C31-A4T2U3
3.2 V ± 1.0%	S-1335C32-N4T1U3	S-1335C32-A4T2U3
3.3 V ± 1.0%	S-1335C33-N4T1U3	S-1335C33-A4T2U3
3.4 V ± 1.0%	S-1335C34-N4T1U3	S-1335C34-A4T2U3
3.5 V ± 1.0%	S-1335C35-N4T1U3	S-1335C35-A4T2U3
3.6 V ± 1.0%	S-1335C36-N4T1U3	S-1335C36-A4T2U3

Remark Please contact our sales office for products with specifications other than the above.

HIGH RIPPLE-REJECTION SOFT-START FUNCTION CMOS VOLTAGE REGULATOR

S-1335 Series

Rev.1.3_00

4.4 S-1335 Series D type

ON / OFF logic: Active "H"
 Discharge shunt function: Unavailable
 Pull-down resistor: Unavailable
 Soft-start time: 0.1 ms typ.

Table 6

Output Voltage	SC-82AB	HSNT-4 (1010)
1.0 V ± 15 mV	S-1335D10-N4T1U3	S-1335D10-A4T2U3
1.1 V ± 15 mV	S-1335D11-N4T1U3	S-1335D11-A4T2U3
1.2 V ± 15 mV	S-1335D12-N4T1U3	S-1335D12-A4T2U3
1.3 V ± 15 mV	S-1335D13-N4T1U3	S-1335D13-A4T2U3
1.4 V ± 15 mV	S-1335D14-N4T1U3	S-1335D14-A4T2U3
1.5 V ± 1.0%	S-1335D15-N4T1U3	S-1335D15-A4T2U3
1.6 V ± 1.0%	S-1335D16-N4T1U3	S-1335D16-A4T2U3
1.7 V ± 1.0%	S-1335D17-N4T1U3	S-1335D17-A4T2U3
1.8 V ± 1.0%	S-1335D18-N4T1U3	S-1335D18-A4T2U3
1.9 V ± 1.0%	S-1335D19-N4T1U3	S-1335D19-A4T2U3
2.0 V ± 1.0%	S-1335D20-N4T1U3	S-1335D20-A4T2U3
2.1 V ± 1.0%	S-1335D21-N4T1U3	S-1335D21-A4T2U3
2.2 V ± 1.0%	S-1335D22-N4T1U3	S-1335D22-A4T2U3
2.3 V ± 1.0%	S-1335D23-N4T1U3	S-1335D23-A4T2U3
2.4 V ± 1.0%	S-1335D24-N4T1U3	S-1335D24-A4T2U3
2.5 V ± 1.0%	S-1335D25-N4T1U3	S-1335D25-A4T2U3
2.6 V ± 1.0%	S-1335D26-N4T1U3	S-1335D26-A4T2U3
2.7 V ± 1.0%	S-1335D27-N4T1U3	S-1335D27-A4T2U3
2.8 V ± 1.0%	S-1335D28-N4T1U3	S-1335D28-A4T2U3
2.85 V ± 1.0%	S-1335D2J-N4T1U3	S-1335D2J-A4T2U3
2.9 V ± 1.0%	S-1335D29-N4T1U3	S-1335D29-A4T2U3
3.0 V ± 1.0%	S-1335D30-N4T1U3	S-1335D30-A4T2U3
3.1 V ± 1.0%	S-1335D31-N4T1U3	S-1335D31-A4T2U3
3.2 V ± 1.0%	S-1335D32-N4T1U3	S-1335D32-A4T2U3
3.3 V ± 1.0%	S-1335D33-N4T1U3	S-1335D33-A4T2U3
3.4 V ± 1.0%	S-1335D34-N4T1U3	S-1335D34-A4T2U3
3.5 V ± 1.0%	S-1335D35-N4T1U3	S-1335D35-A4T2U3
3.6 V ± 1.0%	S-1335D36-N4T1U3	S-1335D36-A4T2U3

Remark Please contact our sales office for products with specifications other than the above.

HIGH RIPPLE-REJECTION SOFT-START FUNCTION CMOS VOLTAGE REGULATOR

Rev.1.3_00

S-1335 Series

4.5 S-1335 Series E type

ON / OFF logic: Active "H"
 Discharge shunt function: Available
 Pull-down resistor: Available
 Soft-start time: 1.0 ms typ.

Table 7

Output Voltage	HSNT-4 (1010)
1.0 V ± 15 mV	S-1335E10-A4T2U3
1.1 V ± 15 mV	S-1335E11-A4T2U3
1.2 V ± 15 mV	S-1335E12-A4T2U3
1.3 V ± 15 mV	S-1335E13-A4T2U3
1.4 V ± 15 mV	S-1335E14-A4T2U3
1.5 V ± 1.0%	S-1335E15-A4T2U3
1.6 V ± 1.0%	S-1335E16-A4T2U3
1.7 V ± 1.0%	S-1335E17-A4T2U3
1.8 V ± 1.0%	S-1335E18-A4T2U3
1.9 V ± 1.0%	S-1335E19-A4T2U3
2.0 V ± 1.0%	S-1335E20-A4T2U3
2.1 V ± 1.0%	S-1335E21-A4T2U3
2.2 V ± 1.0%	S-1335E22-A4T2U3
2.3 V ± 1.0%	S-1335E23-A4T2U3
2.4 V ± 1.0%	S-1335E24-A4T2U3
2.5 V ± 1.0%	S-1335E25-A4T2U3
2.6 V ± 1.0%	S-1335E26-A4T2U3
2.7 V ± 1.0%	S-1335E27-A4T2U3
2.8 V ± 1.0%	S-1335E28-A4T2U3
2.85 V ± 1.0%	S-1335E2J-A4T2U3
2.9 V ± 1.0%	S-1335E29-A4T2U3
3.0 V ± 1.0%	S-1335E30-A4T2U3
3.1 V ± 1.0%	S-1335E31-A4T2U3
3.2 V ± 1.0%	S-1335E32-A4T2U3
3.3 V ± 1.0%	S-1335E33-A4T2U3
3.4 V ± 1.0%	S-1335E34-A4T2U3
3.5 V ± 1.0%	S-1335E35-A4T2U3
3.6 V ± 1.0%	S-1335E36-A4T2U3

Remark Please contact our sales office for products with specifications other than the above.

4.6 S-1335 Series F type

ON / OFF logic: Active "H"
 Discharge shunt function: Available
 Pull-down resistor: Unavailable
 Soft-start time: 1.0 ms typ.

Table 8

Output Voltage	HSNT-4 (1010)
1.0 V ± 15 mV	S-1335F10-A4T2U3
1.1 V ± 15 mV	S-1335F11-A4T2U3
1.2 V ± 15 mV	S-1335F12-A4T2U3
1.3 V ± 15 mV	S-1335F13-A4T2U3
1.4 V ± 15 mV	S-1335F14-A4T2U3
1.5 V ± 1.0%	S-1335F15-A4T2U3
1.6 V ± 1.0%	S-1335F16-A4T2U3
1.7 V ± 1.0%	S-1335F17-A4T2U3
1.8 V ± 1.0%	S-1335F18-A4T2U3
1.9 V ± 1.0%	S-1335F19-A4T2U3
2.0 V ± 1.0%	S-1335F20-A4T2U3
2.1 V ± 1.0%	S-1335F21-A4T2U3
2.2 V ± 1.0%	S-1335F22-A4T2U3
2.3 V ± 1.0%	S-1335F23-A4T2U3
2.4 V ± 1.0%	S-1335F24-A4T2U3
2.5 V ± 1.0%	S-1335F25-A4T2U3
2.6 V ± 1.0%	S-1335F26-A4T2U3
2.7 V ± 1.0%	S-1335F27-A4T2U3
2.8 V ± 1.0%	S-1335F28-A4T2U3
2.85 V ± 1.0%	S-1335F2J-A4T2U3
2.9 V ± 1.0%	S-1335F29-A4T2U3
3.0 V ± 1.0%	S-1335F30-A4T2U3
3.1 V ± 1.0%	S-1335F31-A4T2U3
3.2 V ± 1.0%	S-1335F32-A4T2U3
3.3 V ± 1.0%	S-1335F33-A4T2U3
3.4 V ± 1.0%	S-1335F34-A4T2U3
3.5 V ± 1.0%	S-1335F35-A4T2U3
3.6 V ± 1.0%	S-1335F36-A4T2U3

Remark Please contact our sales office for products with specifications other than the above.

4.7 S-1335 Series G type

ON / OFF logic: Active "H"
 Discharge shunt function: Unavailable
 Pull-down resistor: Available
 Soft-start time: 1.0 ms typ.

Table 9

Output Voltage	HSNT-4 (1010)
1.0 V ± 15 mV	S-1335G10-A4T2U3
1.1 V ± 15 mV	S-1335G11-A4T2U3
1.2 V ± 15 mV	S-1335G12-A4T2U3
1.3 V ± 15 mV	S-1335G13-A4T2U3
1.4 V ± 15 mV	S-1335G14-A4T2U3
1.5 V ± 1.0%	S-1335G15-A4T2U3
1.6 V ± 1.0%	S-1335G16-A4T2U3
1.7 V ± 1.0%	S-1335G17-A4T2U3
1.8 V ± 1.0%	S-1335G18-A4T2U3
1.9 V ± 1.0%	S-1335G19-A4T2U3
2.0 V ± 1.0%	S-1335G20-A4T2U3
2.1 V ± 1.0%	S-1335G21-A4T2U3
2.2 V ± 1.0%	S-1335G22-A4T2U3
2.3 V ± 1.0%	S-1335G23-A4T2U3
2.4 V ± 1.0%	S-1335G24-A4T2U3
2.5 V ± 1.0%	S-1335G25-A4T2U3
2.6 V ± 1.0%	S-1335G26-A4T2U3
2.7 V ± 1.0%	S-1335G27-A4T2U3
2.8 V ± 1.0%	S-1335G28-A4T2U3
2.85 V ± 1.0%	S-1335G2J-A4T2U3
2.9 V ± 1.0%	S-1335G29-A4T2U3
3.0 V ± 1.0%	S-1335G30-A4T2U3
3.1 V ± 1.0%	S-1335G31-A4T2U3
3.2 V ± 1.0%	S-1335G32-A4T2U3
3.3 V ± 1.0%	S-1335G33-A4T2U3
3.4 V ± 1.0%	S-1335G34-A4T2U3
3.5 V ± 1.0%	S-1335G35-A4T2U3
3.6 V ± 1.0%	S-1335G36-A4T2U3

Remark Please contact our sales office for products with specifications other than the above.

4.8 S-1335 Series H type

ON / OFF logic: Active "H"
 Discharge shunt function: Unavailable
 Pull-down resistor: Unavailable
 Soft-start time: 1.0 ms typ.

Table 10

Output Voltage	HSNT-4 (1010)
1.0 V ± 15 mV	S-1335H10-A4T2U3
1.1 V ± 15 mV	S-1335H11-A4T2U3
1.2 V ± 15 mV	S-1335H12-A4T2U3
1.3 V ± 15 mV	S-1335H13-A4T2U3
1.4 V ± 15 mV	S-1335H14-A4T2U3
1.5 V ± 1.0%	S-1335H15-A4T2U3
1.6 V ± 1.0%	S-1335H16-A4T2U3
1.7 V ± 1.0%	S-1335H17-A4T2U3
1.8 V ± 1.0%	S-1335H18-A4T2U3
1.9 V ± 1.0%	S-1335H19-A4T2U3
2.0 V ± 1.0%	S-1335H20-A4T2U3
2.1 V ± 1.0%	S-1335H21-A4T2U3
2.2 V ± 1.0%	S-1335H22-A4T2U3
2.3 V ± 1.0%	S-1335H23-A4T2U3
2.4 V ± 1.0%	S-1335H24-A4T2U3
2.5 V ± 1.0%	S-1335H25-A4T2U3
2.6 V ± 1.0%	S-1335H26-A4T2U3
2.7 V ± 1.0%	S-1335H27-A4T2U3
2.8 V ± 1.0%	S-1335H28-A4T2U3
2.85 V ± 1.0%	S-1335H2J-A4T2U3
2.9 V ± 1.0%	S-1335H29-A4T2U3
3.0 V ± 1.0%	S-1335H30-A4T2U3
3.1 V ± 1.0%	S-1335H31-A4T2U3
3.2 V ± 1.0%	S-1335H32-A4T2U3
3.3 V ± 1.0%	S-1335H33-A4T2U3
3.4 V ± 1.0%	S-1335H34-A4T2U3
3.5 V ± 1.0%	S-1335H35-A4T2U3
3.6 V ± 1.0%	S-1335H36-A4T2U3

Remark Please contact our sales office for products with specifications other than the above.

4.9 S-1335 Series J type

ON / OFF logic: Active "H"
 Discharge shunt function: Available
 Pull-down resistor: Available
 Soft-start time: 0.1 ms typ. / 1.0 ms typ. (Switchable)

Table 11

Output Voltage	SOT-23-5
1.0 V ± 15 mV	S-1335J10-M5T1U3
1.1 V ± 15 mV	S-1335J11-M5T1U3
1.2 V ± 15 mV	S-1335J12-M5T1U3
1.3 V ± 15 mV	S-1335J13-M5T1U3
1.4 V ± 15 mV	S-1335J14-M5T1U3
1.5 V ± 1.0%	S-1335J15-M5T1U3
1.6 V ± 1.0%	S-1335J16-M5T1U3
1.7 V ± 1.0%	S-1335J17-M5T1U3
1.8 V ± 1.0%	S-1335J18-M5T1U3
1.9 V ± 1.0%	S-1335J19-M5T1U3
2.0 V ± 1.0%	S-1335J20-M5T1U3
2.1 V ± 1.0%	S-1335J21-M5T1U3
2.2 V ± 1.0%	S-1335J22-M5T1U3
2.3 V ± 1.0%	S-1335J23-M5T1U3
2.4 V ± 1.0%	S-1335J24-M5T1U3
2.5 V ± 1.0%	S-1335J25-M5T1U3
2.6 V ± 1.0%	S-1335J26-M5T1U3
2.7 V ± 1.0%	S-1335J27-M5T1U3
2.8 V ± 1.0%	S-1335J28-M5T1U3
2.85 V ± 1.0%	S-1335J2J-M5T1U3
2.9 V ± 1.0%	S-1335J29-M5T1U3
3.0 V ± 1.0%	S-1335J30-M5T1U3
3.1 V ± 1.0%	S-1335J31-M5T1U3
3.2 V ± 1.0%	S-1335J32-M5T1U3
3.3 V ± 1.0%	S-1335J33-M5T1U3
3.4 V ± 1.0%	S-1335J34-M5T1U3
3.5 V ± 1.0%	S-1335J35-M5T1U3
3.6 V ± 1.0%	S-1335J36-M5T1U3

Remark Please contact our sales office for products with specifications other than the above.

4. 10 S-1335 Series K type

ON / OFF logic: Active "H"
 Discharge shunt function: Available
 Pull-down resistor: Unavailable
 Soft-start time: 0.1 ms typ. / 1.0 ms typ. (Switchable)

Table 12

Output Voltage	SOT-23-5
1.0 V ± 15 mV	S-1335K10-M5T1U3
1.1 V ± 15 mV	S-1335K11-M5T1U3
1.2 V ± 15 mV	S-1335K12-M5T1U3
1.3 V ± 15 mV	S-1335K13-M5T1U3
1.4 V ± 15 mV	S-1335K14-M5T1U3
1.5 V ± 1.0%	S-1335K15-M5T1U3
1.6 V ± 1.0%	S-1335K16-M5T1U3
1.7 V ± 1.0%	S-1335K17-M5T1U3
1.8 V ± 1.0%	S-1335K18-M5T1U3
1.9 V ± 1.0%	S-1335K19-M5T1U3
2.0 V ± 1.0%	S-1335K20-M5T1U3
2.1 V ± 1.0%	S-1335K21-M5T1U3
2.2 V ± 1.0%	S-1335K22-M5T1U3
2.3 V ± 1.0%	S-1335K23-M5T1U3
2.4 V ± 1.0%	S-1335K24-M5T1U3
2.5 V ± 1.0%	S-1335K25-M5T1U3
2.6 V ± 1.0%	S-1335K26-M5T1U3
2.7 V ± 1.0%	S-1335K27-M5T1U3
2.8 V ± 1.0%	S-1335K28-M5T1U3
2.85 V ± 1.0%	S-1335K2J-M5T1U3
2.9 V ± 1.0%	S-1335K29-M5T1U3
3.0 V ± 1.0%	S-1335K30-M5T1U3
3.1 V ± 1.0%	S-1335K31-M5T1U3
3.2 V ± 1.0%	S-1335K32-M5T1U3
3.3 V ± 1.0%	S-1335K33-M5T1U3
3.4 V ± 1.0%	S-1335K34-M5T1U3
3.5 V ± 1.0%	S-1335K35-M5T1U3
3.6 V ± 1.0%	S-1335K36-M5T1U3

Remark Please contact our sales office for products with specifications other than the above.

4. 11 S-1335 Series L type

ON / OFF logic: Active "H"
 Discharge shunt function: Unavailable
 Pull-down resistor: Available
 Soft-start time: 0.1 ms typ. / 1.0 ms typ. (Switchable)

Table 13

Output Voltage	SOT-23-5
1.0 V ± 15 mV	S-1335L10-M5T1U3
1.1 V ± 15 mV	S-1335L11-M5T1U3
1.2 V ± 15 mV	S-1335L12-M5T1U3
1.3 V ± 15 mV	S-1335L13-M5T1U3
1.4 V ± 15 mV	S-1335L14-M5T1U3
1.5 V ± 1.0%	S-1335L15-M5T1U3
1.6 V ± 1.0%	S-1335L16-M5T1U3
1.7 V ± 1.0%	S-1335L17-M5T1U3
1.8 V ± 1.0%	S-1335L18-M5T1U3
1.9 V ± 1.0%	S-1335L19-M5T1U3
2.0 V ± 1.0%	S-1335L20-M5T1U3
2.1 V ± 1.0%	S-1335L21-M5T1U3
2.2 V ± 1.0%	S-1335L22-M5T1U3
2.3 V ± 1.0%	S-1335L23-M5T1U3
2.4 V ± 1.0%	S-1335L24-M5T1U3
2.5 V ± 1.0%	S-1335L25-M5T1U3
2.6 V ± 1.0%	S-1335L26-M5T1U3
2.7 V ± 1.0%	S-1335L27-M5T1U3
2.8 V ± 1.0%	S-1335L28-M5T1U3
2.85 V ± 1.0%	S-1335L2J-M5T1U3
2.9 V ± 1.0%	S-1335L29-M5T1U3
3.0 V ± 1.0%	S-1335L30-M5T1U3
3.1 V ± 1.0%	S-1335L31-M5T1U3
3.2 V ± 1.0%	S-1335L32-M5T1U3
3.3 V ± 1.0%	S-1335L33-M5T1U3
3.4 V ± 1.0%	S-1335L34-M5T1U3
3.5 V ± 1.0%	S-1335L35-M5T1U3
3.6 V ± 1.0%	S-1335L36-M5T1U3

Remark Please contact our sales office for products with specifications other than the above.

4. 12 S-1335 Series M type

ON / OFF logic: Active "H"
 Discharge shunt function: Unavailable
 Pull-down resistor: Unavailable
 Soft-start time: 0.1 ms typ. / 1.0 ms typ. (Switchable)

Table 14

Output Voltage	SOT-23-5
1.0 V ± 15 mV	S-1335M10-M5T1U3
1.1 V ± 15 mV	S-1335M11-M5T1U3
1.2 V ± 15 mV	S-1335M12-M5T1U3
1.3 V ± 15 mV	S-1335M13-M5T1U3
1.4 V ± 15 mV	S-1335M14-M5T1U3
1.5 V ± 1.0%	S-1335M15-M5T1U3
1.6 V ± 1.0%	S-1335M16-M5T1U3
1.7 V ± 1.0%	S-1335M17-M5T1U3
1.8 V ± 1.0%	S-1335M18-M5T1U3
1.9 V ± 1.0%	S-1335M19-M5T1U3
2.0 V ± 1.0%	S-1335M20-M5T1U3
2.1 V ± 1.0%	S-1335M21-M5T1U3
2.2 V ± 1.0%	S-1335M22-M5T1U3
2.3 V ± 1.0%	S-1335M23-M5T1U3
2.4 V ± 1.0%	S-1335M24-M5T1U3
2.5 V ± 1.0%	S-1335M25-M5T1U3
2.6 V ± 1.0%	S-1335M26-M5T1U3
2.7 V ± 1.0%	S-1335M27-M5T1U3
2.8 V ± 1.0%	S-1335M28-M5T1U3
2.85 V ± 1.0%	S-1335M2J-M5T1U3
2.9 V ± 1.0%	S-1335M29-M5T1U3
3.0 V ± 1.0%	S-1335M30-M5T1U3
3.1 V ± 1.0%	S-1335M31-M5T1U3
3.2 V ± 1.0%	S-1335M32-M5T1U3
3.3 V ± 1.0%	S-1335M33-M5T1U3
3.4 V ± 1.0%	S-1335M34-M5T1U3
3.5 V ± 1.0%	S-1335M35-M5T1U3
3.6 V ± 1.0%	S-1335M36-M5T1U3

Remark Please contact our sales office for products with specifications other than the above.

■ Pin Configurations

1. SOT-23-5

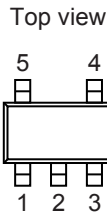

Figure 9

Table 15

Pin No.	Symbol	Description
1	VIN	Input voltage pin
2	VSS	GND pin
3	ON / OFF	ON / OFF pin
4	SST	Switching pin for soft-start time "H": $t_{SS0} = 0.1$ ms typ. "L": $t_{SS1} = 1.0$ ms typ.
5	VOUT	Output voltage pin

Remark The soft-start time can be switched to $t_{SS0} = 0.1$ ms typ. / $t_{SS1} = 1.0$ ms typ. with the SST pin.
Refer to "2. Function list of product type" in "■ Product Name Structure" for details.

2. SC-82AB

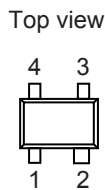

Figure 10

Table 16

Pin No.	Symbol	Description
1	ON / OFF	ON / OFF pin
2	VSS	GND pin
3	VOUT	Output voltage pin
4	VIN	Input voltage pin

Remark The soft-start time is fixed to $t_{SS0} = 0.1$ ms typ.
Refer to "2. Function list of product type" in "■ Product Name Structure" for details.

3. HSNT-4 (1010)

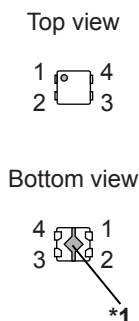

Figure 11

Table 17

Pin No.	Symbol	Description
1	VOUT	Output voltage pin
2	VSS	GND pin
3	ON / OFF	ON / OFF pin
4	VIN	Input voltage pin

Remark The soft-start time is fixed to either $t_{SS0} = 0.1$ ms typ. or $t_{SS1} = 1.0$ ms typ.
Refer to "2. Function list of product type" in "■ Product Name Structure" for details.

- *1. Connect the heat sink of backside at shadowed area to the board, and set electric potential open or GND.
However, do not use it as the function of electrode.

■ **Absolute Maximum Ratings**

Table 18

(Ta = +25°C unless otherwise specified)

Item	Symbol	Absolute Maximum Rating	Unit
Input voltage	V_{IN}	$V_{SS} - 0.3$ to $V_{SS} + 6.0$	V
	$V_{ON/OFF}$	$V_{SS} - 0.3$ to $V_{SS} + 6.0$	V
	V_{SST}	$V_{SS} - 0.3$ to $V_{SS} + 6.0$	V
Output voltage	V_{OUT}	$V_{SS} - 0.3$ to $V_{IN} + 0.3$	V
Output current	I_{OUT}	200	mA
Power dissipation	P_D	SOT-23-5	600 ^{*1}
		SC-82AB	400 ^{*1}
		HSNT-4 (1010)	340 ^{*1}
Operation ambient temperature	T_{opr}	-40 to +85	°C
Storage temperature	T_{stg}	-40 to +125	°C

*1. When mounted on board

[Mounted board]

(1) Board size: 114.3 mm × 76.2 mm × t1.6 mm

(2) Name: JEDEC STANDARD51-7

Caution The absolute maximum ratings are rated values exceeding which the product could suffer physical damage. These values must therefore not be exceeded under any conditions.

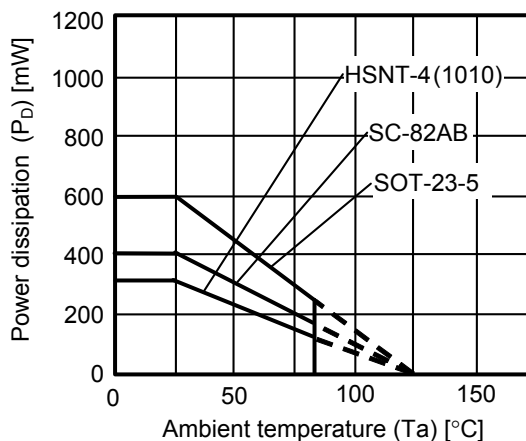

Figure 12 Power Dissipation of Package (When Mounted on Board)

Power Dissipation of HSNT-4 (1010) (Reference)

Power dissipation of package differs depending on the mounting conditions.
 Consider the power dissipation characteristics under the following conditions as reference.

[Mounted board]

- (1) Board size: 40 mm × 40 mm × t0.8 mm
- (2) Board material: Glass epoxy resin (four layers)
- (3) Wiring ratio: 50%
- (4) Test conditions: When mounted on board (wind speed: 0 m/s)
- (5) Land pattern: Refer to the recommended land pattern (drawing code: PL004-A-L-SD)

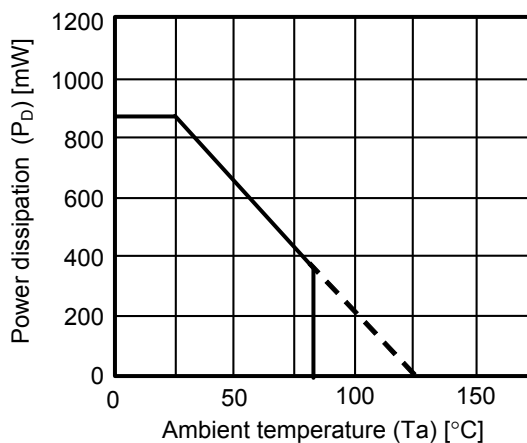

Figure 13 Power Dissipation of Package (When Mounted on Board)

Table 19

Condition	Power Dissipation (Reference)	Thermal Resistance Value ($\theta_j - a$)
HSNT-4 (1010) (When mounted on board)	870 mW	115°C/W

■ **Electrical Characteristics**

1. **S-1335 Series A / B / C / D / E / F / G / H type**

Table 20

(Ta = +25°C unless otherwise specified)

Item	Symbol	Condition	Min.	Typ.	Max.	Unit	Test Circuit		
Output voltage* ¹	V _{OUT(E)}	V _{IN} = V _{OUT(S)} + 1.0 V, I _{OUT} = 30 mA	1.0 V ≤ V _{OUT(S)} < 1.5 V	V _{OUT(S)} − 0.015	V _{OUT(S)}	V _{OUT(S)} + 0.015	V	1	
			1.5 V ≤ V _{OUT(S)} ≤ 3.6 V	V _{OUT(S)} × 0.99	V _{OUT(S)}	V _{OUT(S)} × 1.01	V	1	
Output current* ²	I _{OUT}	V _{IN} ≥ V _{OUT(S)} + 1.0 V	150* ⁵	–	–	mA	3		
Dropout voltage* ³	V _{drop}	I _{OUT} = 100 mA	1.0 V ≤ V _{OUT(S)} < 1.1 V	0.130	0.250	0.350	V	1	
			1.1 V ≤ V _{OUT(S)} < 1.2 V	–	0.225	0.275	V	1	
			1.2 V ≤ V _{OUT(S)} < 1.3 V	–	0.194	0.224	V	1	
			1.3 V ≤ V _{OUT(S)} < 1.4 V	–	0.160	0.187	V	1	
			1.4 V ≤ V _{OUT(S)} < 1.5 V	–	0.124	0.167	V	1	
			1.5 V ≤ V _{OUT(S)} < 1.7 V	–	0.104	0.157	V	1	
			1.7 V ≤ V _{OUT(S)} < 2.0 V	–	0.094	0.140	V	1	
			2.0 V ≤ V _{OUT(S)} < 2.5 V	–	0.084	0.127	V	1	
		2.5 V ≤ V _{OUT(S)} < 2.8 V	–	0.077	0.117	V	1		
		2.8 V ≤ V _{OUT(S)} ≤ 3.6 V	–	0.070	0.103	V	1		
Line regulation	$\frac{\Delta V_{OUT1}}{\Delta V_{IN} \cdot V_{OUT}}$	V _{OUT(S)} + 0.5 V ≤ V _{IN} ≤ 5.5 V, I _{OUT} = 30 mA	–	0.05	0.2	%/V	1		
Load regulation	$\frac{\Delta V_{OUT2}}{\Delta V_{IN} \cdot V_{OUT}}$	V _{IN} = V _{OUT(S)} + 1.0 V, 1 mA ≤ I _{OUT} ≤ 150 mA	–	15	40	mV	1		
Output voltage temperature coefficient* ⁴	$\frac{\Delta V_{OUT}}{\Delta T_a \cdot V_{OUT}}$	V _{IN} = V _{OUT(S)} + 1.0 V, I _{OUT} = 30 mA, −40°C ≤ Ta ≤ +85°C	–	±100	–	ppm/°C	1		
Current consumption during operation	I _{SS1}	V _{IN} = V _{OUT(S)} + 1.0 V, ON / OFF pin = ON, no load	–	36	54	μA	2		
Current consumption during power-off	I _{SS2}	V _{IN} = V _{OUT(S)} + 1.0 V, ON / OFF pin = OFF, no load	–	0.1	1.0	μA	2		
Input voltage	V _{IN}	–	1.5	–	5.5	V	–		
ON / OFF pin input voltage "H"	V _{SH}	V _{IN} = V _{OUT(S)} + 1.0 V, R _L = 1.0 kΩ determined by V _{OUT} output level	1.0	–	–	V	4		
ON / OFF pin input voltage "L"	V _{SL}	V _{IN} = V _{OUT(S)} + 1.0 V, R _L = 1.0 kΩ determined by V _{OUT} output level	–	–	0.3	V	4		
ON / OFF pin input current "H"	I _{SH}	V _{IN} = 5.5 V, V _{ON / OFF} = 5.5 V	B / D / F / H type (without pull-down resistor)	−0.1	–	0.1	μA	4	
			A / C / E / G type (with pull-down resistor)	1.0	2.5	5.0	μA	4	
ON / OFF pin input current "L"	I _{SL}	V _{IN} = 5.5 V, V _{ON / OFF} = 0 V	−0.1	–	0.1	μA	4		
Ripple rejection	RR	V _{IN} = V _{OUT(S)} + 1.0 V, f = 10 kHz, ΔV _{rip} = 0.5 Vrms, I _{OUT} = 30 mA	1.0 V ≤ V _{OUT(S)} ≤ 2.5 V	–	70	–	dB	5	
			2.5 V < V _{OUT(S)} ≤ 3.6 V	–	65	–	dB	5	
		V _{IN} = V _{OUT(S)} + 1.0 V, f = 1.0 kHz, ΔV _{rip} = 0.5 Vrms, I _{OUT} = 30 mA	1.0 V ≤ V _{OUT(S)} ≤ 3.6 V	–	80	–	dB	5	
Short-circuit current	I _{short}	V _{IN} = V _{OUT(S)} + 1.0 V, ON / OFF pin = ON, V _{OUT} = 0 V	–	50	–	mA	3		
Soft-start time* ⁶	t _{SS0}	V _{IN} = V _{OUT(S)} + 1.0 V, I _{OUT} = 100 mA,	A / B / C / D type (0.1 ms typ.)		0.08	0.1	0.13	ms	1
	t _{SS1}	C _L = 1.0 μF, t _r = 1.0 μs	E / F / G / H type (1.0 ms typ.)		0.8	1.0	1.2	ms	1
"L" output Nch ON resistance	R _{LOW}	V _{IN} = 5.5 V, V _{OUT} = 0.1 V	A / B / E / F type (with discharge shunt function)		–	35	–	Ω	3
Power-off pull-down resistance	R _{PD}	–	A / C / E / G type (with pull-down resistor)		1.1	2.2	5.5	MΩ	4

- *1. $V_{OUT(S)}$: Set output voltage
 $V_{OUT(E)}$: Actual output voltage
 Output voltage when fixing I_{OUT} (= 30 mA) and inputting $V_{OUT(S)} + 1.0$ V
- *2. The output current at which the output voltage becomes 95% of $V_{OUT(E)}$ after gradually increasing the output current.
- *3. $V_{drop} = V_{IN1} - (V_{OUT3} \times 0.98)$
 V_{OUT3} is the output voltage when $V_{IN} = V_{OUT(S)} + 1.0$ V and $I_{OUT} = 100$ mA.
 V_{IN1} is the input voltage at which the output voltage becomes 98% of V_{OUT3} after gradually decreasing the input voltage.
- *4. A change in temperature of the output voltage [mV/°C] is calculated using the following equation.

$$\frac{\Delta V_{OUT}}{\Delta T_a} \text{ [mV/°C]}^{*1} = V_{OUT(S)} \text{ [V]}^{*2} \times \frac{\Delta V_{OUT}}{\Delta T_a \bullet V_{OUT}} \text{ [ppm/°C]}^{*3} \div 1000$$
 - *1. Change in temperature of output voltage
 - *2. Set output voltage
 - *3. Output voltage temperature coefficient
- *5. The output current can be at least this value.
 Due to restrictions on the package power dissipation, this value may not be satisfied. Attention should be paid to the power dissipation of the package when the output current is large.
 This specification is guaranteed by design.
- *6. Soft-start time shows the time period from when the input voltage reaches 50% until the output voltage rises to 99%, immediately after power-on or when the ON / OFF pin is set to ON ($t_r = 1.0$ μs). Refer to "**8. Soft-start function**" in "**■ Operation**" for details.

HIGH RIPPLE-REJECTION SOFT-START FUNCTION CMOS VOLTAGE REGULATOR

S-1335 Series

Rev.1.3_00

2. S-1335 Series J / K / L / M type

Table 21

(Ta = +25°C unless otherwise specified)

Item	Symbol	Condition	Min.	Typ.	Max.	Unit	Test Circuit	
Output voltage* ¹	V _{OUT(E)}	V _{IN} = V _{OUT(S)} + 1.0 V, I _{OUT} = 30 mA	1.0 V ≤ V _{OUT(S)} < 1.5 V	V _{OUT(S)} - 0.015	V _{OUT(S)}	V _{OUT(S)} + 0.015	V	6
			1.5 V ≤ V _{OUT(S)} ≤ 3.6 V	V _{OUT(S)} × 0.99	V _{OUT(S)}	V _{OUT(S)} × 1.01	V	6
Output current* ²	I _{OUT}	V _{IN} ≥ V _{OUT(S)} + 1.0 V	150* ⁵	–	–	mA	8	
Dropout voltage* ³	V _{drop}	I _{OUT} = 100 mA	1.0 V ≤ V _{OUT(S)} < 1.1 V	0.130	0.250	0.350	V	6
			1.1 V ≤ V _{OUT(S)} < 1.2 V	–	0.225	0.275	V	6
			1.2 V ≤ V _{OUT(S)} < 1.3 V	–	0.194	0.224	V	6
			1.3 V ≤ V _{OUT(S)} < 1.4 V	–	0.160	0.187	V	6
			1.4 V ≤ V _{OUT(S)} < 1.5 V	–	0.124	0.167	V	6
			1.5 V ≤ V _{OUT(S)} < 1.7 V	–	0.104	0.157	V	6
			1.7 V ≤ V _{OUT(S)} < 2.0 V	–	0.094	0.140	V	6
			2.0 V ≤ V _{OUT(S)} < 2.5 V	–	0.084	0.127	V	6
Line regulation	$\frac{\Delta V_{OUT1}}{\Delta V_{IN} \cdot V_{OUT}}$	V _{OUT(S)} + 0.5 V ≤ V _{IN} ≤ 5.5 V, I _{OUT} = 30 mA	–	0.05	0.2	%/V	6	
			–	0.05	0.2	%/V	6	
Load regulation	$\frac{\Delta V_{OUT2}}{\Delta V_{OUT}}$	V _{IN} = V _{OUT(S)} + 1.0 V, 1 mA ≤ I _{OUT} ≤ 150 mA	–	15	40	mV	6	
Output voltage temperature coefficient* ⁴	$\frac{\Delta V_{OUT}}{\Delta T_a \cdot V_{OUT}}$	V _{IN} = V _{OUT(S)} + 1.0 V, I _{OUT} = 30 mA, –40°C ≤ Ta ≤ +85°C	–	±100	–	ppm/°C	6	
Current consumption during operation	I _{SS1}	V _{IN} = V _{OUT(S)} + 1.0 V, ON / OFF pin = ON, no load	–	36	54	μA	7	
Current consumption during power-off	I _{SS2}	V _{IN} = V _{OUT(S)} + 1.0 V, ON / OFF pin = OFF, no load	–	0.1	1.0	μA	7	
Input voltage	V _{IN}	–	1.5	–	5.5	V	–	
ON / OFF pin input voltage "H"	V _{SH}	V _{IN} = V _{OUT(S)} + 1.0 V, R _L = 1.0 kΩ determined by V _{OUT} output level	1.0	–	–	V	9	
ON / OFF pin input voltage "L"	V _{SL}	V _{IN} = V _{OUT(S)} + 1.0 V, R _L = 1.0 kΩ determined by V _{OUT} output level	–	–	0.3	V	9	
ON / OFF pin input current "H"	I _{SH}	V _{IN} = 5.5 V, V _{ON / OFF} = 5.5 V	K / M type (without pull-down resistor)	–0.1	–	0.1	μA	9
			J / L type (with pull-down resistor)	1.0	2.5	5.0	μA	9
ON / OFF pin input current "L"	I _{SL}	V _{IN} = 5.5 V, V _{ON / OFF} = 0 V	–0.1	–	0.1	μA	9	
Ripple rejection	RR	V _{IN} = V _{OUT(S)} + 1.0 V, f = 10 kHz, ΔV _{rip} = 0.5 Vrms, I _{OUT} = 30 mA	1.0 V ≤ V _{OUT(S)} ≤ 2.5 V	–	70	–	dB	10
			2.5 V < V _{OUT(S)} ≤ 3.6 V	–	65	–	dB	10
		V _{IN} = V _{OUT(S)} + 1.0 V, f = 1.0 kHz, ΔV _{rip} = 0.5 Vrms, I _{OUT} = 30 mA	1.0 V ≤ V _{OUT(S)} ≤ 3.6 V	–	80	–	dB	10
Short-circuit current	I _{short}	V _{IN} = V _{OUT(S)} + 1.0 V, ON / OFF pin = ON, V _{OUT} = 0 V	–	50	–	mA	8	
Soft-start time* ⁶	t _{SS0}	V _{IN} = V _{OUT(S)} + 1.0 V, I _{OUT} = 100 mA, V _{SST} = "H"	0.08	0.1	0.13	ms	6	
	t _{SS1}	C _L = 1.0 μF, t _r = 1.0 μs, V _{SST} = "L"	0.8	1.0	1.2	ms	6	
"L" output Nch ON resistance	R _{LOW}	V _{IN} = 5.5 V, V _{OUT} = 0.1 V	–	35	–	Ω	8	
Power-off pull-down resistance	R _{PD}	–	1.1	2.2	5.5	MΩ	9	
SST pin input voltage "H"	V _{SH2}	V _{IN} = V _{ON / OFF} = V _{OUT(S)} + 1.0 V, R _L = 1.0 kΩ, determined by V _{OUT} output level	1.0	–	–	V	9	
SST pin input voltage "L"	V _{SL2}	V _{IN} = V _{ON / OFF} = V _{OUT(S)} + 1.0 V, R _L = 1.0 kΩ, determined by V _{OUT} output level	–	–	0.3	V	9	
SST pin input current "H"	I _{SH2}	V _{IN} = 5.5 V, V _{SST} = 5.5 V	–0.1	–	0.1	μA	9	
SST pin input current "L"	I _{SL2}	V _{IN} = 5.5 V, V _{SST} = 0 V	1.0	2.5	5.0	μA	9	
SST pin pull-up resistance	R _{PU}	–	1.1	2.2	5.5	MΩ	9	

- *1. $V_{OUT(S)}$: Set output voltage
 $V_{OUT(E)}$: Actual output voltage
 Output voltage when fixing I_{OUT} (= 30 mA) and inputting $V_{OUT(S)} + 1.0$ V
- *2. The output current at which the output voltage becomes 95% of $V_{OUT(E)}$ after gradually increasing the output current.
- *3. $V_{drop} = V_{IN1} - (V_{OUT3} \times 0.98)$
 V_{OUT3} is the output voltage when $V_{IN} = V_{OUT(S)} + 1.0$ V and $I_{OUT} = 100$ mA.
 V_{IN1} is the input voltage at which the output voltage becomes 98% of V_{OUT3} after gradually decreasing the input voltage.
- *4. A change in temperature of the output voltage [mV/°C] is calculated using the following equation.

$$\frac{\Delta V_{OUT}}{\Delta T_a} \text{ [mV/°C]}^{*1} = V_{OUT(S)} \text{ [V]}^{*2} \times \frac{\Delta V_{OUT}}{\Delta T_a \cdot V_{OUT}} \text{ [ppm/°C]}^{*3} \div 1000$$
 - *1. Change in temperature of output voltage
 - *2. Set output voltage
 - *3. Output voltage temperature coefficient
- *5. The output current can be at least this value.
 Due to restrictions on the package power dissipation, this value may not be satisfied. Attention should be paid to the power dissipation of the package when the output current is large.
 This specification is guaranteed by design.
- *6. Soft-start time shows the time period from when the input voltage reaches 50% until the output voltage rises to 99%, immediately after power-on or when the ON / OFF pin is set to ON ($t_r = 1.0$ μs). Refer to "8. **Soft-start function**" in "■ **Operation**" for details.

■ **Test Circuits**

1. S-1335 Series A / B / C / D / E / F / G / H type

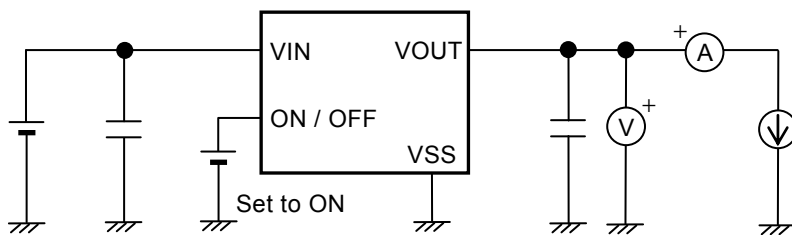

Figure 14 Test Circuit 1

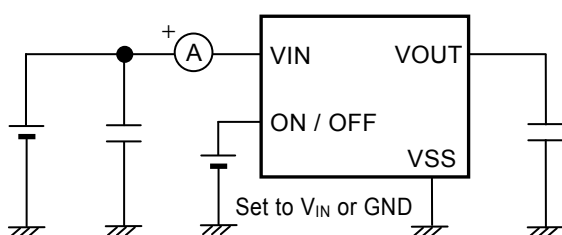

Figure 15 Test Circuit 2

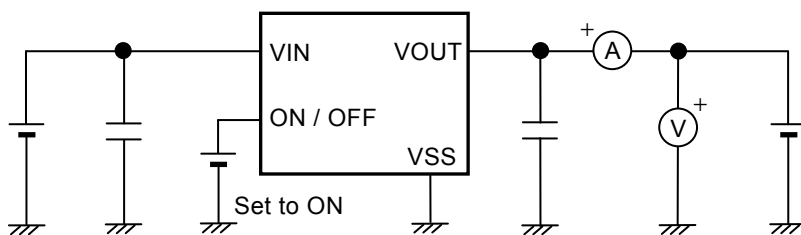

Figure 16 Test Circuit 3

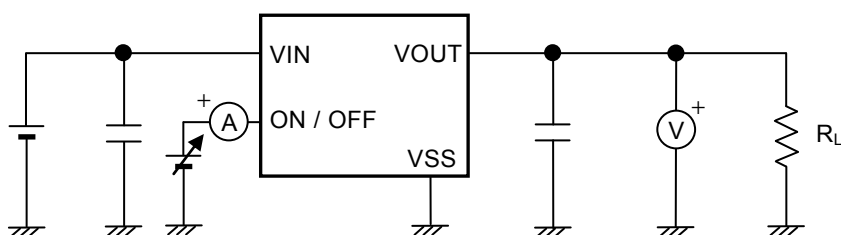

Figure 17 Test Circuit 4

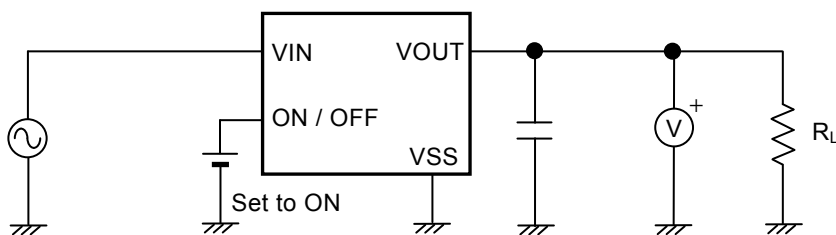

Figure 18 Test Circuit 5

2. S-1335 Series J / K / L / M type

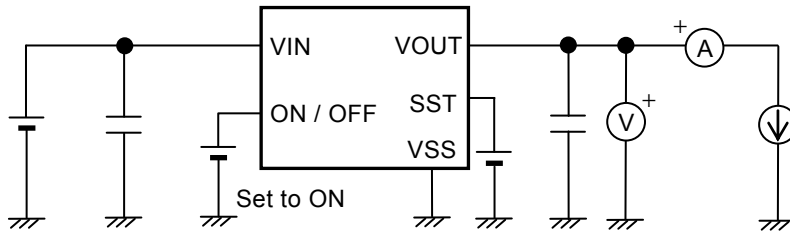

Figure 19 Test Circuit 6

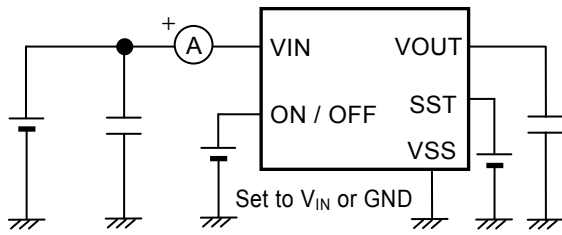

Figure 20 Test Circuit 7

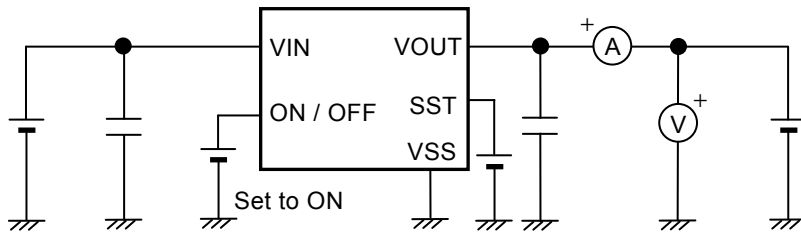

Figure 21 Test Circuit 8

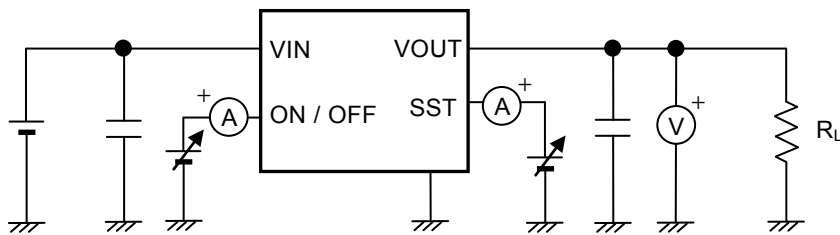

Figure 22 Test Circuit 9

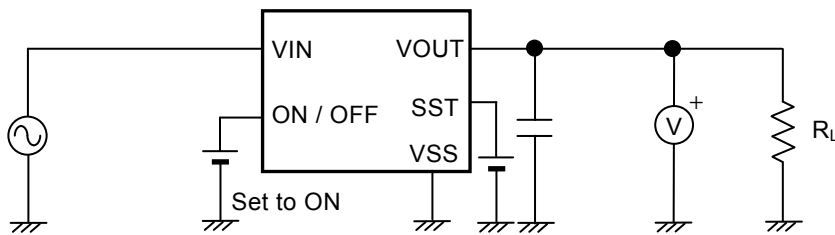
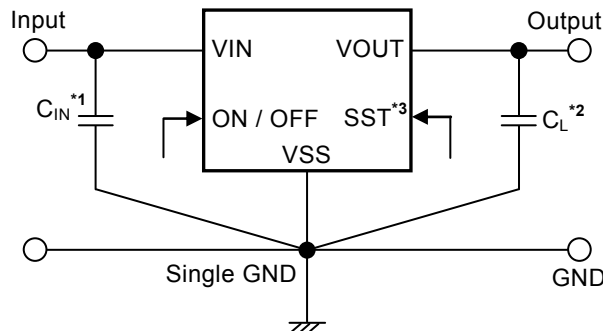

Figure 23 Test Circuit 10

■ **Standard Circuit**



- *1. C_{IN} is a capacitor for stabilizing the input.
- *2. A Ceramic capacitor of 1.0 μF or more can be used as C_L .
- *3. S-1335 Series J / K / L / M type only.

Figure 24

Caution The above connection diagram and constant will not guarantee successful operation. Perform thorough evaluation using the actual application to set the constant.

■ **Condition of Application**

Input capacitor (C_{IN}): 1.0 μF or more
 Output capacitor (C_L): 1.0 μF or more

- Caution**
1. Set input capacitor (C_{IN}) and output capacitor (C_L) as $C_{IN} = C_L$.
 2. Generally a series regulator may cause oscillation, depending on the selection of external parts. Confirm that no oscillation occurs in the application for which the above capacitors are used.

■ **Selection of Input and Output Capacitors (C_{IN} , C_L)**

The S-1335 Series requires an output capacitor between the VOUT pin and the VSS pin for phase compensation. Operation is stabilized by a ceramic capacitor with an output capacitance of 1.0 μF or more over the entire temperature range. When using an OS capacitor, a tantalum capacitor, or an aluminum electrolytic capacitor, the capacitance must be 1.0 μF or more.

The values of output overshoot and undershoot, which are transient response characteristics, vary depending on the value of output capacitor.

The required value of capacitance for the input capacitor differs depending on the application.

Set the value for input capacitor (C_{IN}) and output capacitor (C_L) as follows. Define the values by sufficient evaluation including the temperature characteristics under the usage condition.

- $C_{IN} \geq 1.0 \mu\text{F}$
- $C_L \geq 1.0 \mu\text{F}$
- $C_{IN} = C_L$

■ Explanation of Terms

1. Low dropout voltage regulator

This voltage regulator has the low dropout voltage due to its built-in low on-resistance transistor.

2. Output voltage (V_{OUT})

The accuracy of the output voltage is ensured at $\pm 1.0\%$ or $\pm 15 \text{ mV}^{*1}$ under the specified conditions of fixed input voltage^{*2}, fixed output current, and fixed temperature.

*1. When $V_{OUT} < 1.5 \text{ V}$: $\pm 15 \text{ mV}$, when $V_{OUT} \geq 1.5 \text{ V}$: $\pm 1.0\%$

*2. Differs depending on the product.

Caution If the above conditions change, the output voltage value may vary and exceed the accuracy range of the output voltage. Refer to "■ Electrical Characteristics" and "■ Characteristics (Typical Data)" for details.

3. Line regulation $\left(\frac{\Delta V_{OUT1}}{\Delta V_{IN} \cdot V_{OUT}} \right)$

Indicates the dependency of the output voltage on the input voltage. That is, the values show how much the output voltage changes due to a change in the input voltage with the output current remaining unchanged.

4. Load regulation (ΔV_{OUT2})

Indicates the dependency of the output voltage on the output current. That is, the values show how much the output voltage changes due to a change in the output current with the input voltage remaining unchanged.

5. Dropout voltage (V_{drop})

Indicates the difference between input voltage (V_{IN1}) and the output voltage when; decreasing input voltage (V_{IN}) gradually until the output voltage has dropped out to the value of 98% of output voltage (V_{OUT3}), which is at $V_{IN} = V_{OUT(S)} + 1.0 \text{ V}$.

$$V_{drop} = V_{IN1} - (V_{OUT3} \times 0.98)$$

6. Output voltage temperature coefficient $\left(\frac{\Delta V_{OUT}}{\Delta T_a \bullet V_{OUT}}\right)$

The shaded area in **Figure 25** is the range where V_{OUT} varies in the operation temperature range when the output voltage temperature coefficient is ± 100 ppm/ $^{\circ}\text{C}$.

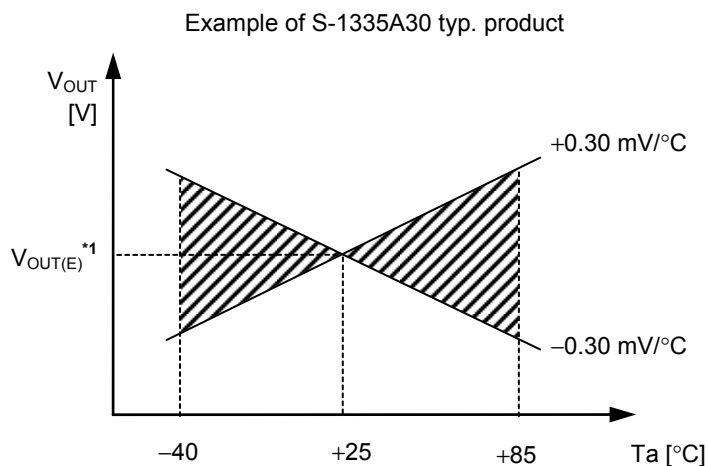

*1. $V_{OUT(E)}$ is the value of the output voltage measured at $T_a = +25^{\circ}\text{C}$.

Figure 25

A change in the temperature of the output voltage [mV/ $^{\circ}\text{C}$] is calculated using the following equation.

$$\frac{\Delta V_{OUT}}{\Delta T_a} \text{ [mV/}^{\circ}\text{C]}^{*1} = V_{OUT(S)} \text{ [V]}^{*2} \times \frac{\Delta V_{OUT}}{\Delta T_a \bullet V_{OUT}} \text{ [ppm/}^{\circ}\text{C]}^{*3} \div 1000$$

- *1. Change in temperature of output voltage
- *2. Set output voltage
- *3. Output voltage temperature coefficient

■ Operation

1. Basic operation

Figure 26 shows the block diagram of the S-1335 Series.

The error amplifier compares the reference voltage (V_{ref}) with feedback voltage (V_{fb}), which is the output voltage resistance-divided by feedback resistors (R_s and R_f). It supplies the gate voltage necessary to maintain the constant output voltage which is not influenced by the input voltage and temperature change, to the output transistor.

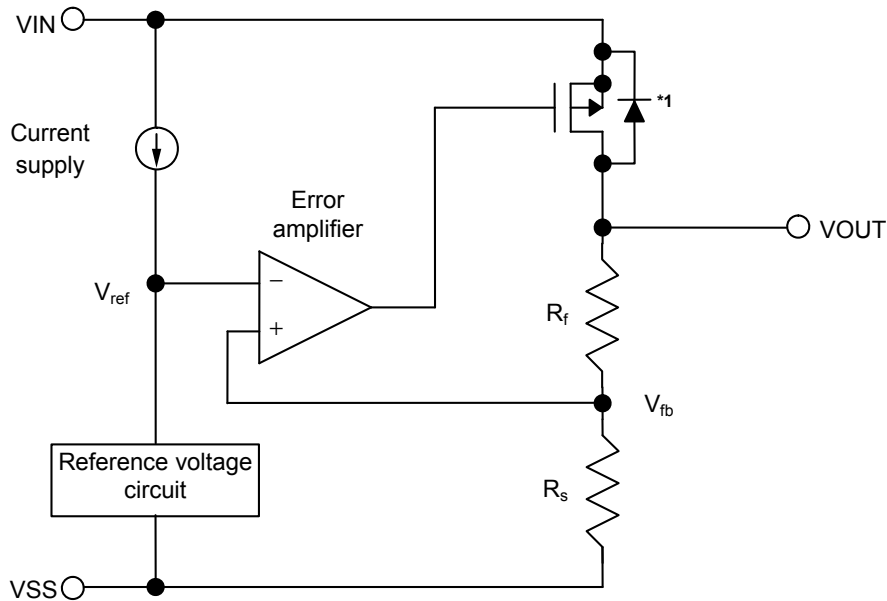

*1. Parasitic diode

Figure 26

2. Output transistor

In the S-1335 Series, a low on-resistance P-channel MOS FET is used as the output transistor.

Be sure that V_{OUT} does not exceed $V_{IN} + 0.3$ V to prevent the voltage regulator from being damaged due to inverse current flowing from the VOUT pin through a parasitic diode to the VIN pin, when the potential of V_{OUT} became higher than V_{IN} .

3. ON / OFF pin

This pin starts and stops the regulator.

When the ON / OFF pin is set to OFF level, the entire internal circuit stops operating, and the built-in P-channel MOS FET output transistor between the VIN pin and the VOUT pin is turned off, reducing current consumption significantly. Note that the current consumption increases when a voltage of 0.3 V to 1.0 V is applied to the ON / OFF pin. The ON / OFF pin is configured as shown in **Figure 27** and **Figure 28**.

3.1 S-1335 Series A / C / E / G / J / L type

The ON / OFF pin is internally pulled down to the VSS pin in the floating status, so the VOUT pin is set to the V_{SS} level.

3.2 S-1335 Series B / D / F / H / K / M type

The ON / OFF pin is not internally pulled up or pulled down to the VSS pin, so do not use it in the floating status. When not using the ON / OFF pin, connect the pin to the VIN pin.

Table 22

Product Type	ON / OFF Pin	Internal Circuit	VOUT Pin Voltage	Current Consumption
A / B / C / D / E / F / G / H / J / K / L / M	"H": ON	Operate	Set value	I _{SS1} *1
A / B / C / D / E / F / G / H / J / K / L / M	"L": OFF	Stop	V _{SS} level	I _{SS2}

*1. Note that the IC's current consumption increases as much as current flows into the pull-down resistor of 2.2 MΩ typ. when the ON / OFF pin is connected to the VIN pin and the S-1335 Series A / C / E / G / J / L type is operating (refer to **Figure 27**).

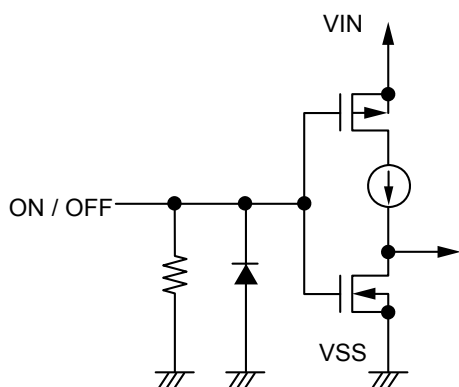

Figure 27 S-1335 Series A / C / E / G / J / L type

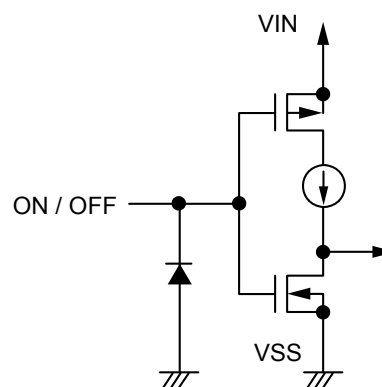

Figure 28 S-1335 Series B / D / F / H / K / M type

4. Discharge shunt function (S-1335 Series A / B / E / F / J / K type)

The S-1335 Series A / B / E / F / J / K type has a built-in discharge shunt circuit to discharge the output capacitance. The output capacitance is discharged as follows so that the VOUT pin reaches the V_{SS} level.

- (1) The ON / OFF pin is set to OFF level.
- (2) The output transistor is turned off.
- (3) The discharge shunt circuit is turned on.
- (4) The output capacitor discharges.

Since the S-1335 Series C / D / G / H / L / M type does not have a discharge shunt circuit, the VOUT pin is set to the V_{SS} level through several hundred kΩ internal divided resistors between the VOUT pin and the VSS pin. The S-1335 Series A / B / E / F / J / K type allows the VOUT pin to reach the V_{SS} level rapidly due to the discharge shunt circuit.

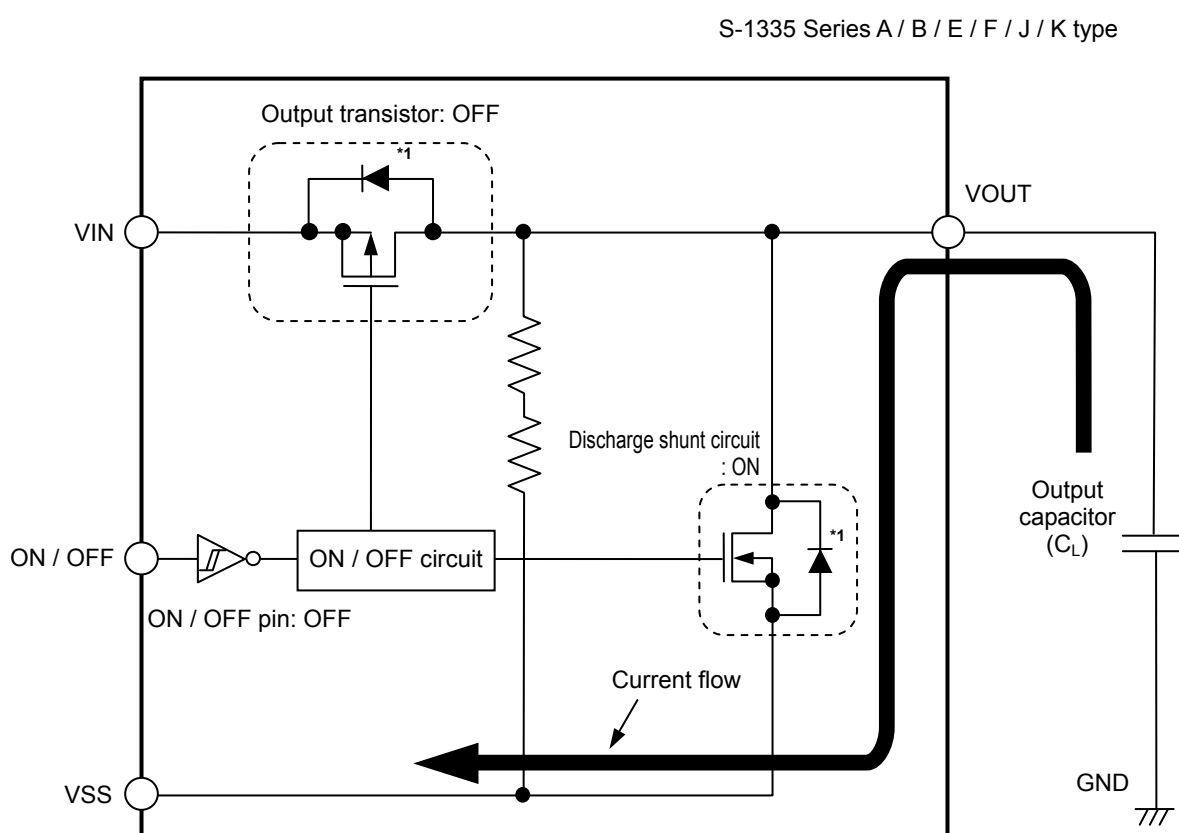

*1. Parasitic diode

Figure 29

5. Pull-down resistor (S-1335 Series A / C / E / G / J / L type)

The ON / OFF pin is internally pulled down to the VSS pin in the floating status, so the VOUT pin is set to the V_{SS} level.

Note that the IC's current consumption increases as much as current flows into the pull-down resistor of 2.2 MΩ typ. when the ON / OFF pin is connected to the VIN pin.

6. Overcurrent protection circuit

The S-1335 Series includes an overcurrent protection circuit having the characteristics shown in "1. Output voltage vs. Output current (When load current increases) (Ta = +25°C)" in "■ Characteristics (Typical Data)", in order to protect the output transistor against an excessive output current and short circuiting between the VOUT pin and the VSS pin.

The current when the output pin is short-circuited (I_{short}) is internally set at approx. 50 mA typ., and the normal value is restored for the output voltage, if releasing a short circuit once.

Caution This overcurrent protection circuit does not work as for thermal protection. If this IC long keeps short circuiting inside, pay attention to the conditions of input voltage and load current so that, under the usage conditions including short circuit, the loss of the IC will not exceed power dissipation of the package.

7. SST pin (S-1335 Series J / K / L / M type only)

In the S-1335 Series J / K / L / M type, the soft-start time can be switched with the SST pin. The soft-start time is set to 0.1 ms typ. if "H" is input to the SST pin, and set to 1.0 ms typ. if "L" is input to the SST pin. Refer to "8. 2 Switching of soft-start time (S-1335 Series J / K / L / M type only)" for details.

The SST pin is configured as shown in Figure 30.

Note that the current consumption increases when a voltage of 0.3 V to 1.0 V is applied to the SST pin.

Since the SST pin is pulled up by the VIN pin internally, the soft-start time is fixed to 0.1 ms typ. on floating status.

Note that the IC's current consumption increases as much as current flows into the pull-up resistor of 2.2 MΩ typ. when the SST pin is connected to the VSS pin and the S-1335 Series J / K / L / M type is operating (refer to Figure 30).

Table 23

SST Pin Input	Soft-start Time (typ.)
"H"	0.1 ms
"L"	1.0 ms

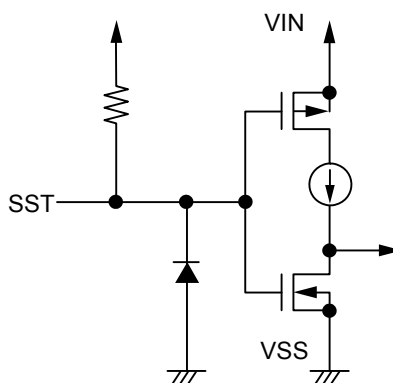

Figure 30 S-1335 Series J / K / L / M type

8. Soft-start function

8.1 Basic operation

The S-1335 Series has a built-in soft-start circuit to suppress the inrush current and overshoot of the output voltage generated at power-on or at the time when the ON / OFF pin is set to ON. Immediately after power-on or after the ON / OFF pin is set to ON, the output voltage slowly rises.

Immediately after power-on or when the ON / OFF pin is set to ON ($t_r = 1.0 \mu s$), the soft-start time (t_{ss}) is the time period from when the input voltage reaches 50% until the output voltage rises to 99%.

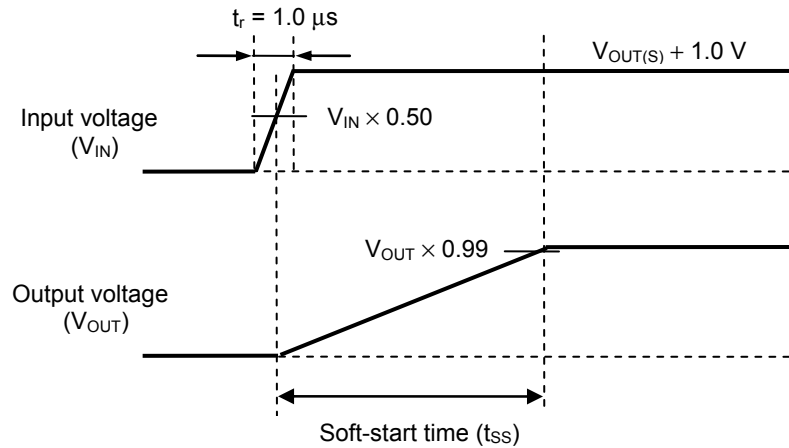

Figure 31 Basic Operation

The inrush current can be suppressed greatly by the soft-start function.

Figure 32 shows the waveform example of the inrush current.

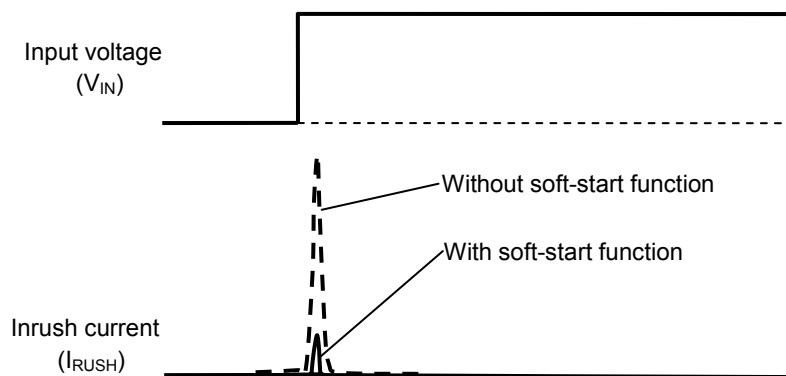

Figure 32 Waveform Example of Inrush Current

8.2 Switching of soft-start time (S-1335 Series J / K / L / M type only)

In the S-1335 Series J / K / L / M type, the soft-start time can be switched to $t_{SS0} = 0.1 \text{ ms typ.}$ / $t_{SS1} = 1.0 \text{ ms typ.}$ with the SST pin.

However, the soft-start time (t_{SS}) is as follows when the SST pin is switched within the soft-start time $t_{SS0} = 0.1 \text{ ms typ.}$ / $t_{SS1} = 1.0 \text{ ms typ.}$

8.2.1 When SST pin voltage (V_{SST}) is switched from "H" to "L"

The soft-start time (t_{SS}) is calculated by using the following equation.

$$t_{SS} = t_{SS0}' + t_{SS1} \times \{1 - V_{OUT(E)'} / (V_{OUT(E)} \times 0.99)\}$$

t_{SS0}' : The time period that V_{SST} is switched from "H" to "L" after power-on

t_{SS1} : The soft-start time when $V_{SST} = \text{"L"}$

$V_{OUT(E)'}$: The output voltage when V_{SST} is switched from "H" to "L"

$V_{OUT(E)}$: The output voltage after the end of the soft-start time

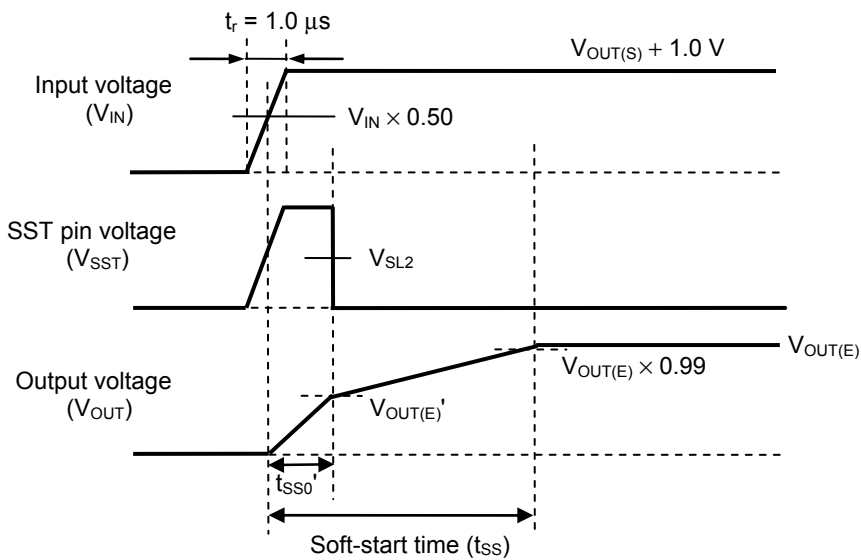

Figure 33 $V_{SST} = \text{"H"} \rightarrow \text{"L"}$

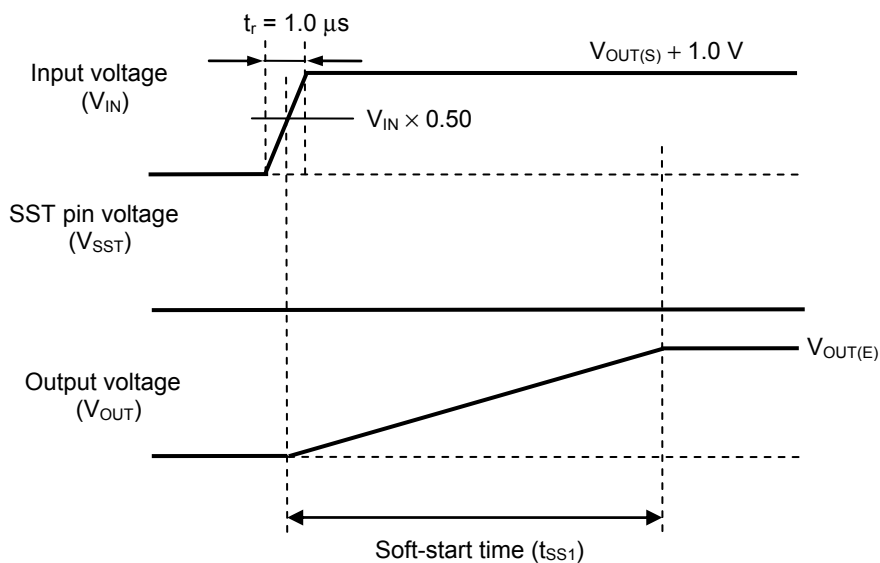

Figure 34 $V_{SST} = \text{"L"}$

8. 2. 2 When SST pin voltage (V_{SST}) is switched from "L" to "H"

The soft-start time (t_{SS}) is calculated by using the following equation.

$$t_{SS} = t_{SS1}' + t_{SS0} \times \{1 - V_{OUT(E)'} / (V_{OUT(E)} \times 0.99)\}$$

t_{SS1}' : The time period that V_{SST} is switched from "L" to "H" after power-on

t_{SS0} : The soft-start time when $V_{SST} = "H"$

$V_{OUT(E)'}$: The output voltage when V_{SST} is switched from "L" to "H"

$V_{OUT(E)}$: The output voltage after the end of the soft-start time

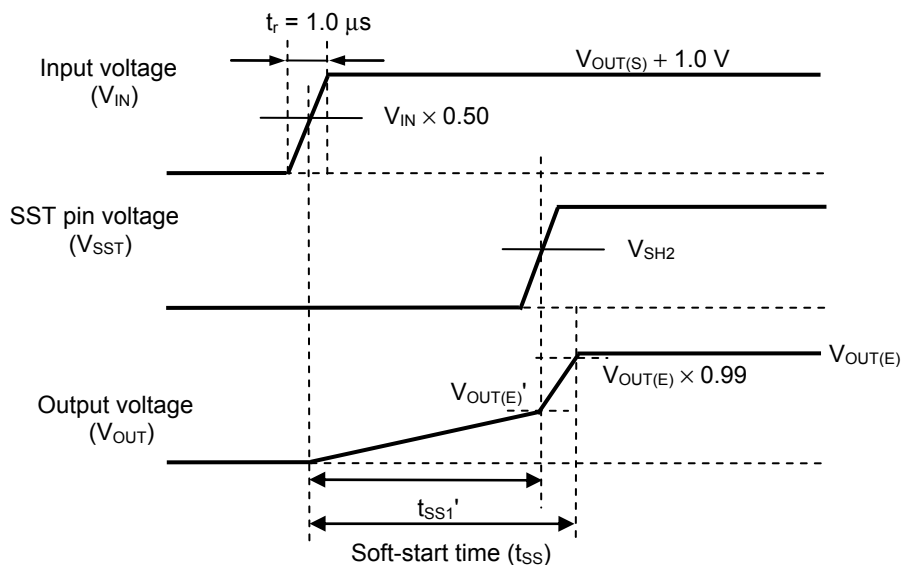

Figure 35 $V_{SST} = "L" \rightarrow "H"$

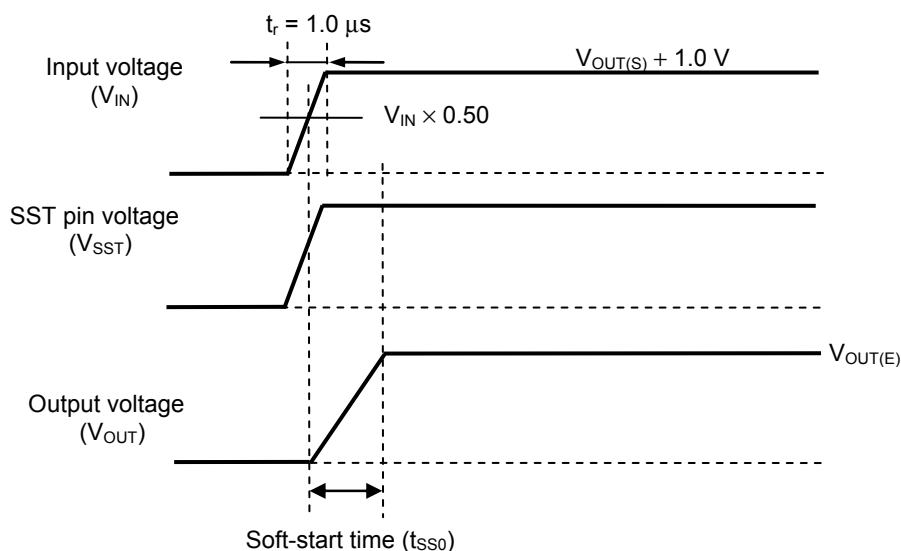

Figure 36 $V_{SST} = "H"$

■ Precautions

- Wiring patterns for the VIN pin, the VOUT pin and GND should be designed so that the impedance is low. When mounting an output capacitor between the VOUT pin and the VSS pin (C_L) and a capacitor for stabilizing the input between the VIN pin and the VSS pin (C_{IN}), the distance from the capacitors to these pins should be as short as possible.
- Note that generally the output voltage may increase when a series regulator is used at low load current (1.0 mA or less).
- Note that generally the output voltage may increase due to the leakage current from an output driver when a series regulator is used at high temperature.
- Note that the output voltage may increase due to the leakage current from an output driver even if the ON / OFF pin is at OFF level when a series regulator is used at high temperature.
- Generally a series regulator may cause oscillation, depending on the selection of external parts. The following conditions are recommended for the S-1335 Series. However, be sure to perform sufficient evaluation under the actual usage conditions for selection, including evaluation of temperature characteristics. Refer to "6. Example of equivalent series resistance vs. Output current characteristics ($T_a = +25^\circ\text{C}$)" in "■ Reference Data" for the equivalent series resistance (R_{ESR}) of the output capacitor.

Input capacitor (C_{IN}):	1.0 μF or more
Output capacitor (C_L):	1.0 μF or more

- The voltage regulator may oscillate when the impedance of the power supply is high and the input capacitance is small or an input capacitor is not connected.
- If the output capacitance is small, power supply's fluctuation and the characteristics of load fluctuation become worse. Sufficiently evaluate the output voltage's fluctuation with the actual device.
- Overshoot may occur in the output voltage momentarily if the voltage is rapidly raised at power-on or when the power supply fluctuates. Sufficiently evaluate the output voltage at power-on with the actual device.
- The application conditions for the input voltage, the output voltage, and the load current should not exceed the package power dissipation.
- Do not apply an electrostatic discharge to this IC that exceeds the performance ratings of the built-in electrostatic protection circuit.
- In determining the output current, attention should be paid to the output current value specified in **Table 20** and **Table 21** in "■ Electrical Characteristics" and footnote *5 of the table.
- SII claims no responsibility for any disputes arising out of or in connection with any infringement by products including this IC of patents owned by a third party.

■ Characteristics (Typical Data)

1. Output voltage vs. Output current (When load current increases) ($T_a = +25^\circ\text{C}$)

1.1 $V_{OUT} = 1.0\text{ V}$

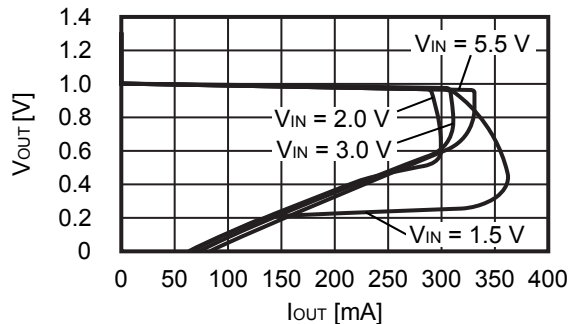

1.2 $V_{OUT} = 2.5\text{ V}$

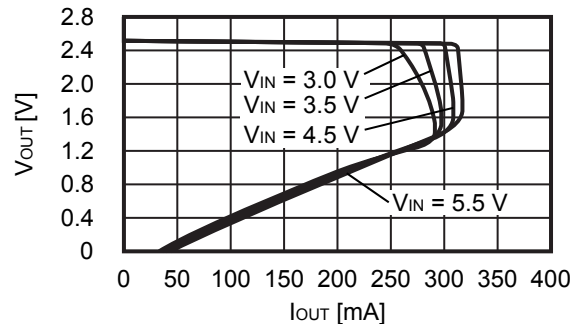

1.3 $V_{OUT} = 3.6\text{ V}$

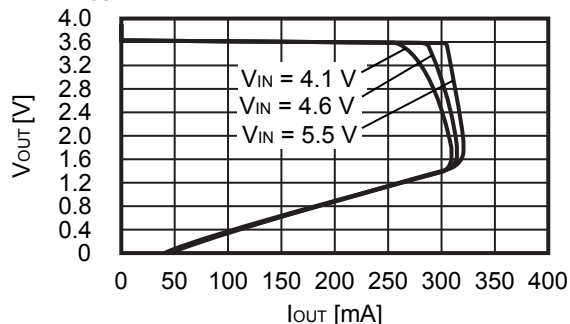

Remark In determining the output current, attention should be paid to the following.

1. The minimum output current value and footnote *5 in Table 20 and Table 21 in "■ Electrical Characteristics"
2. The package power dissipation

2. Output voltage vs. Input voltage ($T_a = +25^\circ\text{C}$)

2.1 $V_{OUT} = 1.0\text{ V}$

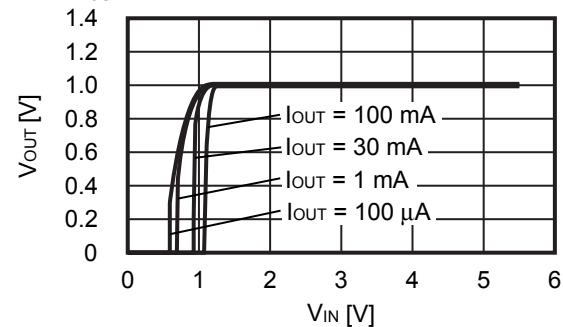

2.2 $V_{OUT} = 2.5\text{ V}$

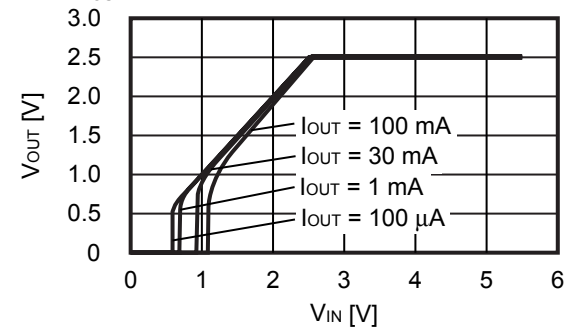

2.3 $V_{OUT} = 3.6\text{ V}$

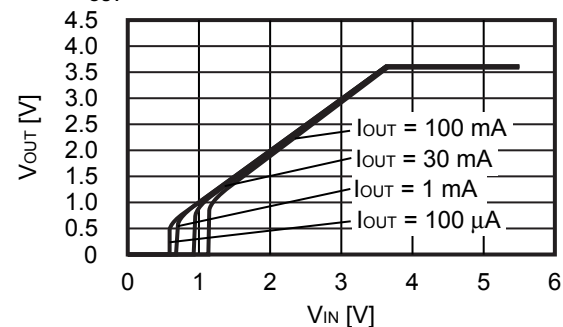

3. Dropout voltage vs. Output current

3.1 $V_{OUT} = 1.0\text{ V}$

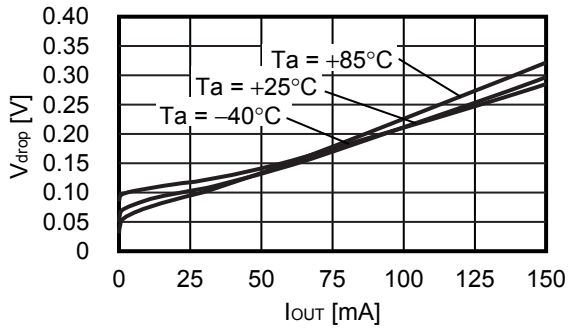

3.2 $V_{OUT} = 2.5\text{ V}$

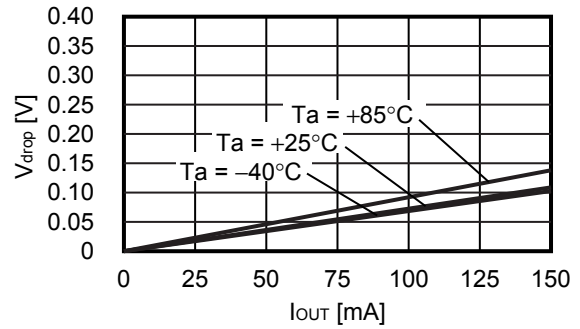

3.3 $V_{OUT} = 3.6\text{ V}$

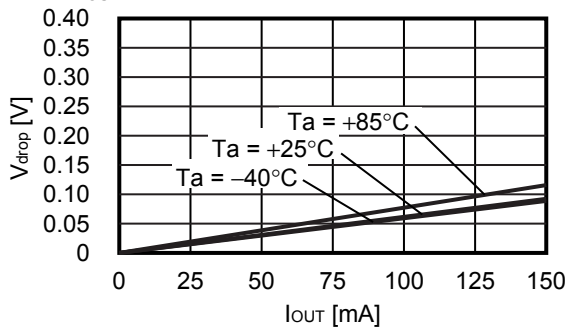

4. Dropout voltage vs. Set output voltage

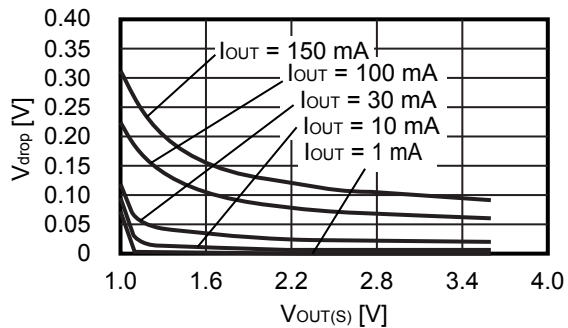

5. Output voltage vs. Ambient temperature

5.1 $V_{OUT} = 1.0\text{ V}$

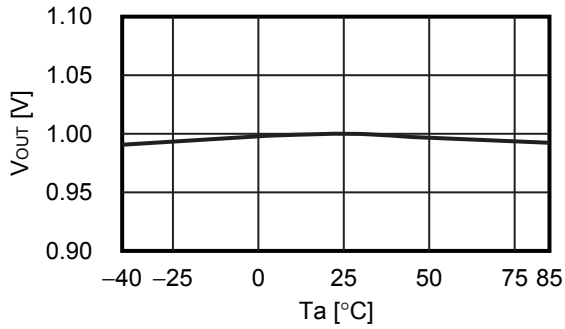

5.2 $V_{OUT} = 2.5\text{ V}$

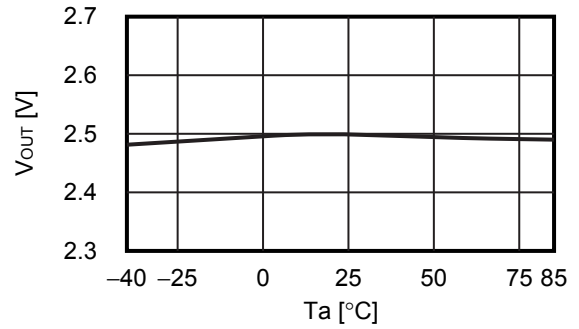

5.3 $V_{OUT} = 3.6\text{ V}$

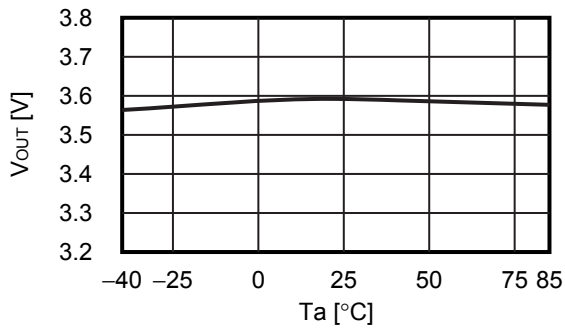

6. Current consumption vs. Input voltage

6.1 $V_{OUT} = 1.0\text{ V}$

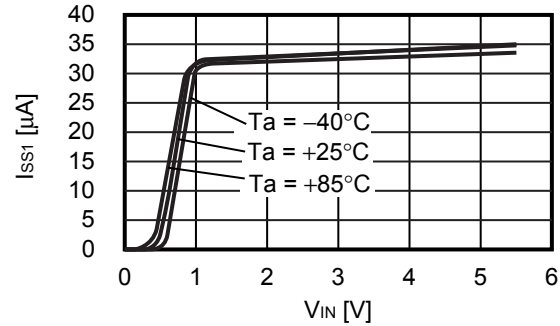

6.2 $V_{OUT} = 2.5\text{ V}$

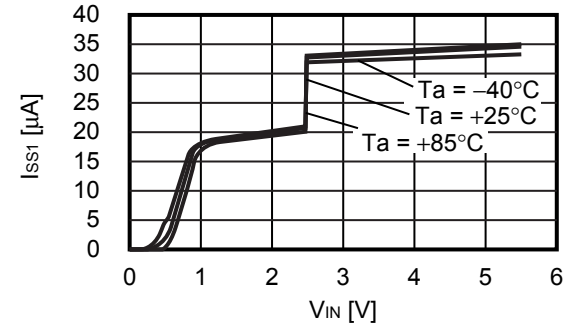

6.3 $V_{OUT} = 3.6\text{ V}$

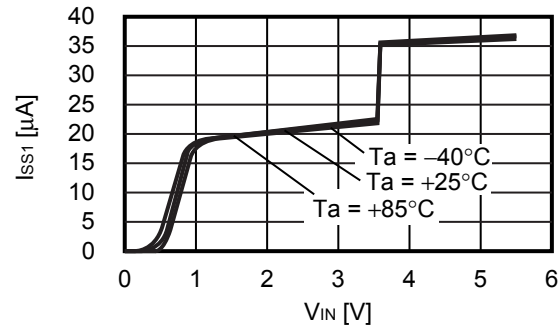

7. Ripple rejection (Ta = +25°C)

7.1 V_{OUT} = 1.0 V

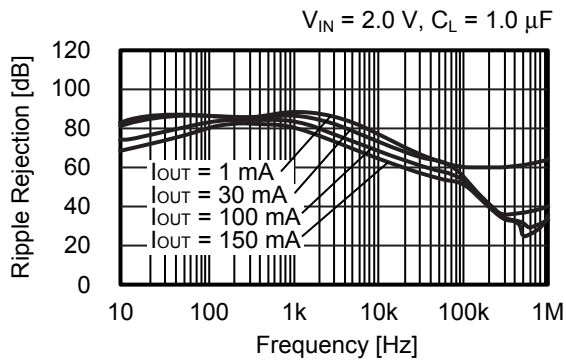

7.2 V_{OUT} = 2.5 V

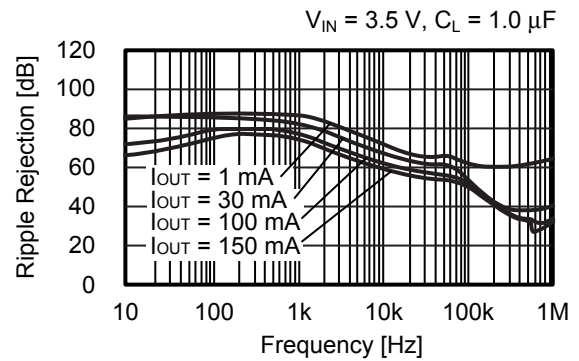

7.3 V_{OUT} = 3.6 V

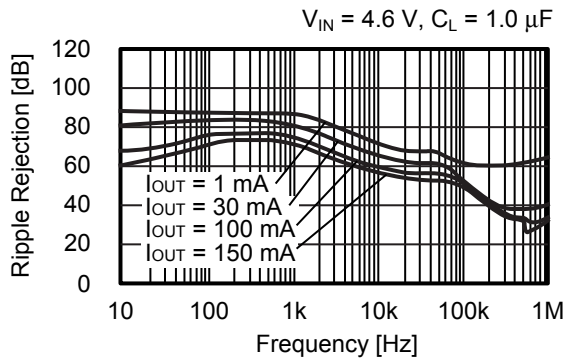

■ Reference Data

1. Transient response characteristics when input ($T_a = +25^\circ\text{C}$)

1.1 $V_{OUT} = 1.0\text{ V}$

$I_{OUT} = 30\text{ mA}$, $C_{IN} = C_L = 1.0\ \mu\text{F}$,
 $V_{IN} = 2.0\text{ V} \leftrightarrow 3.0\text{ V}$, $t_r = t_f = 5.0\ \mu\text{s}$

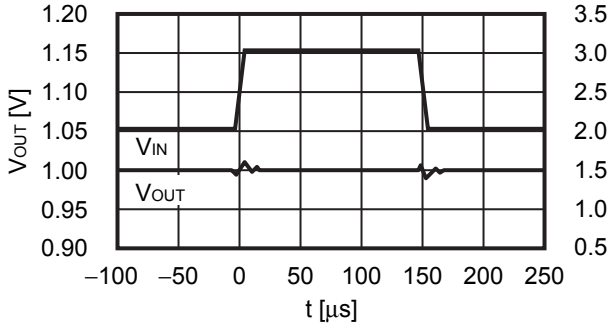

1.2 $V_{OUT} = 2.5\text{ V}$

$I_{OUT} = 30\text{ mA}$, $C_{IN} = C_L = 1.0\ \mu\text{F}$,
 $V_{IN} = 3.5\text{ V} \leftrightarrow 4.5\text{ V}$, $t_r = t_f = 5.0\ \mu\text{s}$

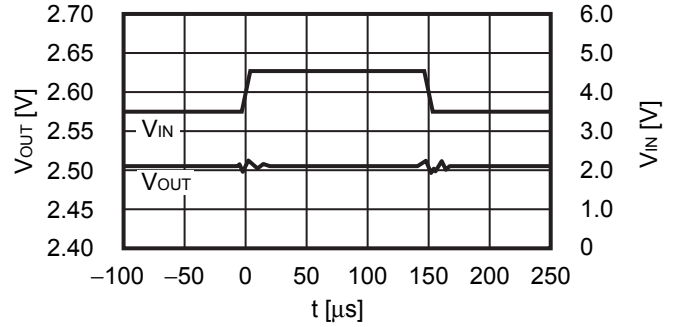

1.3 $V_{OUT} = 3.6\text{ V}$

$I_{OUT} = 30\text{ mA}$, $C_{IN} = C_L = 1.0\ \mu\text{F}$,
 $V_{IN} = 4.6\text{ V} \leftrightarrow 5.5\text{ V}$, $t_r = t_f = 5.0\ \mu\text{s}$

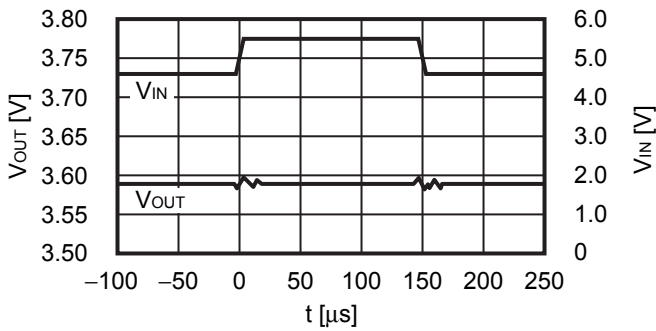

2. Transient response characteristics of load (Ta = +25°C)

2.1 V_{OUT} = 1.0 V

V_{IN} = 2.0 V, C_{IN} = C_L = 1.0 μF, I_{OUT} = 50 mA ↔ 100 mA

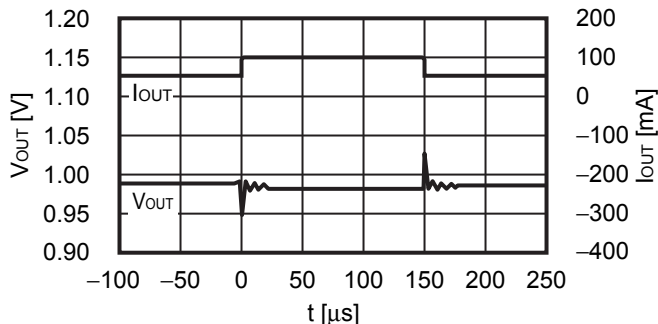

V_{IN} = 2.0 V, C_{IN} = C_L = 1.0 μF, I_{OUT} = 1 mA ↔ 150 mA

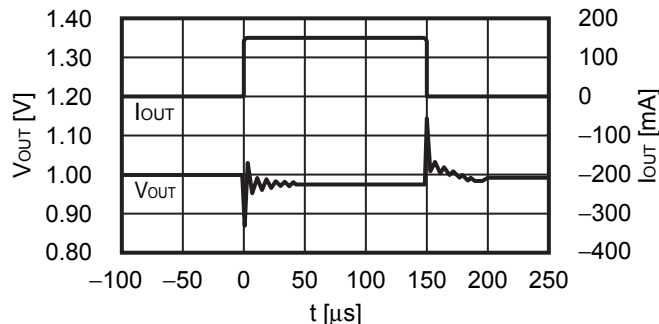

2.2 V_{OUT} = 2.5 V

V_{IN} = 3.5 V, C_{IN} = C_L = 1.0 μF, I_{OUT} = 50 mA ↔ 100 mA

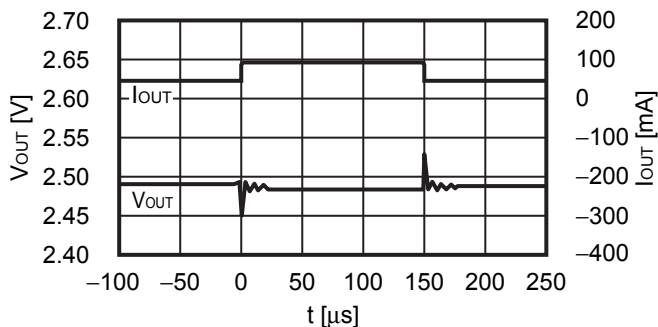

V_{IN} = 3.5 V, C_{IN} = C_L = 1.0 μF, I_{OUT} = 1 mA ↔ 150 mA

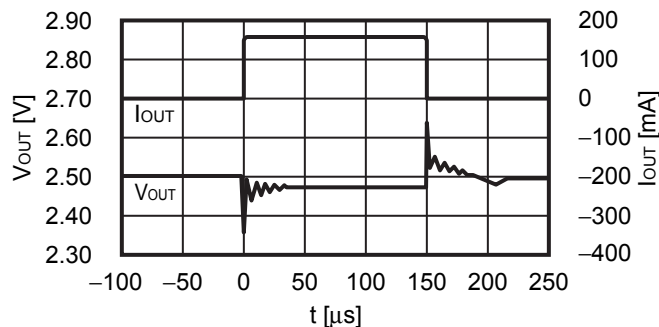

2.3 V_{OUT} = 3.6 V

V_{IN} = 4.6 V, C_{IN} = C_L = 1.0 μF, I_{OUT} = 50 mA ↔ 100 mA

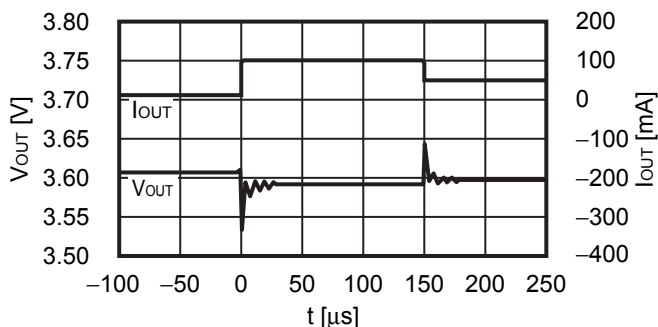

V_{IN} = 4.6 V, C_{IN} = C_L = 1.0 μF, I_{OUT} = 1 mA ↔ 150 mA

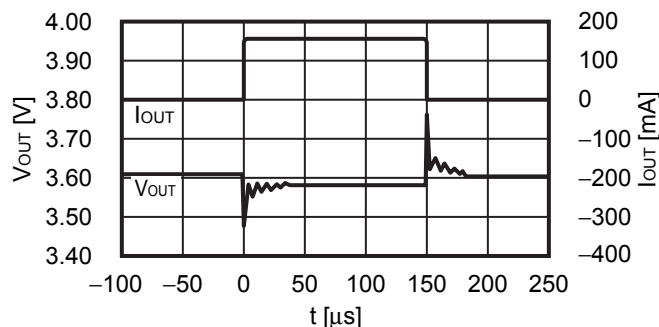

3. Transient response characteristics of ON / OFF pin ($T_a = +25^\circ\text{C}$)

3.1 $V_{\text{OUT}} = 1.0 \text{ V}$

3.1.1 $t_{\text{SS}} = 0.1 \text{ ms}$

$V_{\text{IN}} = 2.0 \text{ V}$, $C_{\text{IN}} = C_{\text{L}} = 1.0 \mu\text{F}$, $I_{\text{OUT}} = 100 \text{ mA}$,
 $V_{\text{ON/OFF}} = 0 \text{ V} \rightarrow 2.0 \text{ V}$, $t_r = 1.0 \mu\text{s}$

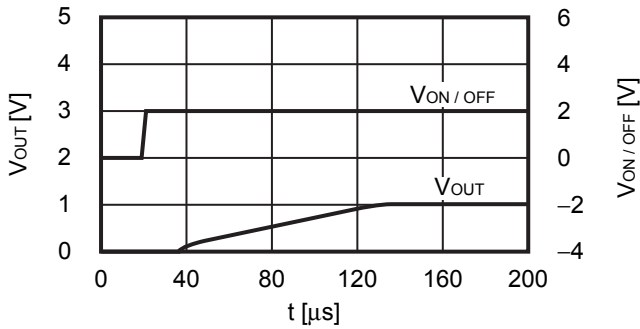

3.1.2 $t_{\text{SS}} = 1.0 \text{ ms}$

$V_{\text{IN}} = 2.0 \text{ V}$, $C_{\text{IN}} = C_{\text{L}} = 1.0 \mu\text{F}$, $I_{\text{OUT}} = 100 \text{ mA}$,
 $V_{\text{ON/OFF}} = 0 \text{ V} \rightarrow 2.0 \text{ V}$, $t_r = 1.0 \mu\text{s}$

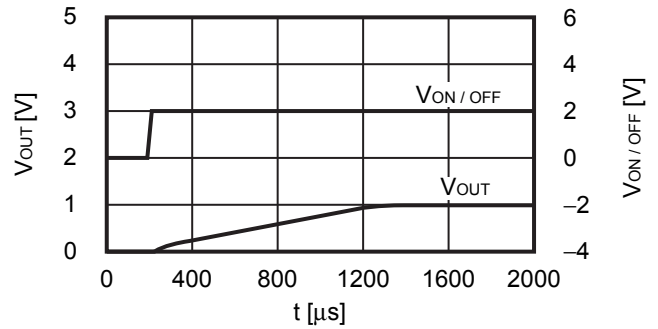

3.2 $V_{\text{OUT}} = 2.5 \text{ V}$

3.2.1 $t_{\text{SS}} = 0.1 \text{ ms}$

$V_{\text{IN}} = 3.5 \text{ V}$, $C_{\text{IN}} = C_{\text{L}} = 1.0 \mu\text{F}$, $I_{\text{OUT}} = 100 \text{ mA}$,
 $V_{\text{ON/OFF}} = 0 \text{ V} \rightarrow 3.5 \text{ V}$, $t_r = 1.0 \mu\text{s}$

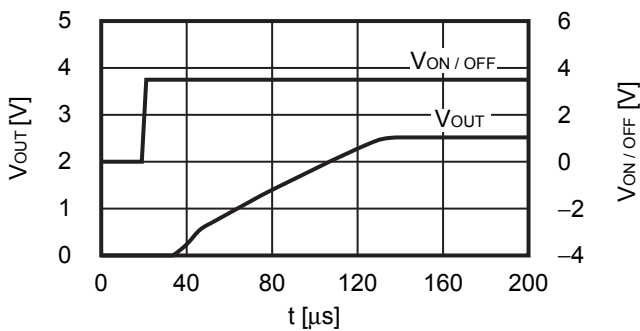

3.2.2 $t_{\text{SS}} = 1.0 \text{ ms}$

$V_{\text{IN}} = 3.5 \text{ V}$, $C_{\text{IN}} = C_{\text{L}} = 1.0 \mu\text{F}$, $I_{\text{OUT}} = 100 \text{ mA}$,
 $V_{\text{ON/OFF}} = 0 \text{ V} \rightarrow 3.5 \text{ V}$, $t_r = 1.0 \mu\text{s}$

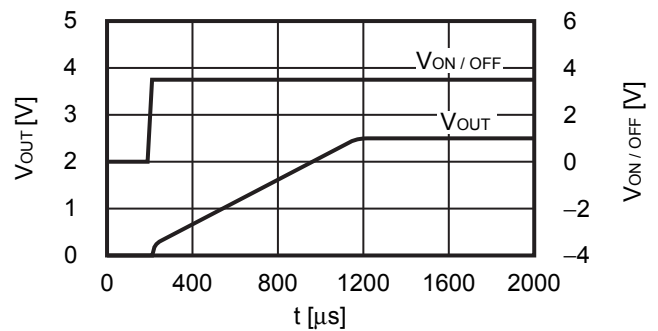

3.3 $V_{\text{OUT}} = 3.6 \text{ V}$

3.3.1 $t_{\text{SS}} = 0.1 \text{ ms}$

$V_{\text{IN}} = 4.6 \text{ V}$, $C_{\text{IN}} = C_{\text{L}} = 1.0 \mu\text{F}$, $I_{\text{OUT}} = 100 \text{ mA}$,
 $V_{\text{ON/OFF}} = 0 \text{ V} \rightarrow 4.6 \text{ V}$, $t_r = 1.0 \mu\text{s}$

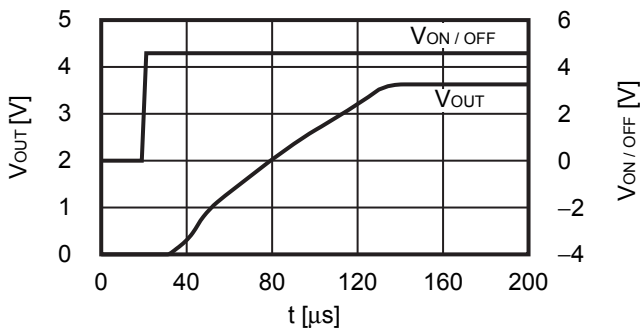

3.3.2 $t_{\text{SS}} = 1.0 \text{ ms}$

$V_{\text{IN}} = 4.6 \text{ V}$, $C_{\text{IN}} = C_{\text{L}} = 1.0 \mu\text{F}$, $I_{\text{OUT}} = 100 \text{ mA}$,
 $V_{\text{ON/OFF}} = 0 \text{ V} \rightarrow 4.6 \text{ V}$, $t_r = 1.0 \mu\text{s}$

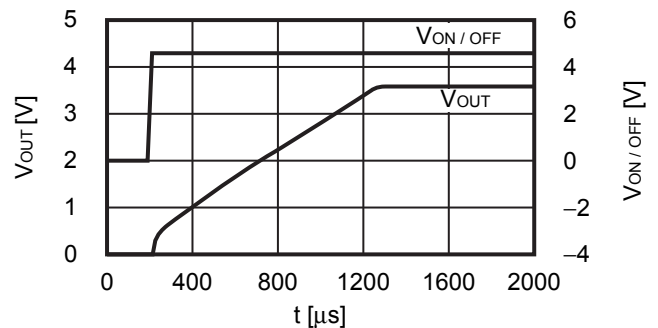

4. Inrush current characteristics (Ta = +25°C)

4.1 V_{OUT} = 1.0 V

4.1.1 t_{SS} = 0.1 ms

V_{IN} = 2.0 V, C_{IN} = C_L = 1.0 μF, I_{OUT} = 0.1 mA,
 V_{ON/OFF} = 0 V → 2.0 V, t_r = 1.0 μs

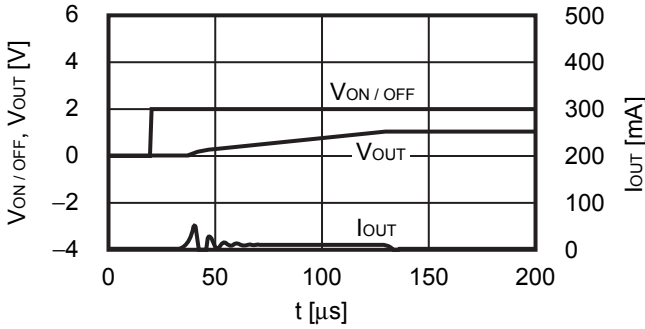

4.1.2 t_{SS} = 1.0 ms

V_{IN} = 2.0 V, C_{IN} = C_L = 1.0 μF, I_{OUT} = 0.1 mA,
 V_{ON/OFF} = 0 V → 2.0 V, t_r = 1.0 μs

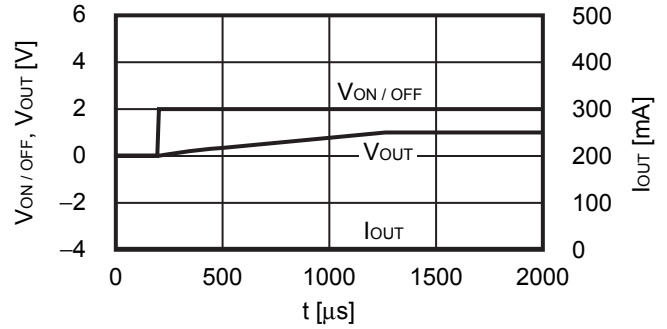

4.2 V_{OUT} = 2.5 V

4.2.1 t_{SS} = 0.1 ms

V_{IN} = 3.5 V, C_{IN} = C_L = 1.0 μF, I_{OUT} = 0.1 mA,
 V_{ON/OFF} = 0 V → 3.5 V, t_r = 1.0 μs

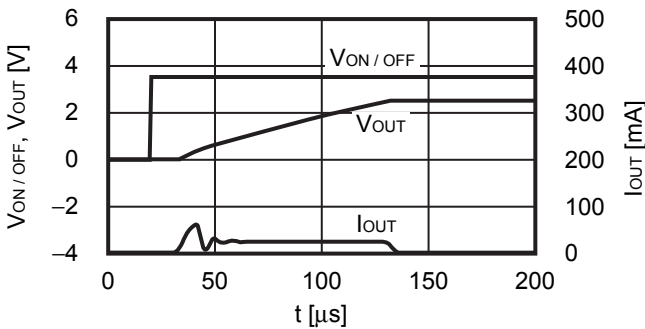

4.2.2 t_{SS} = 1.0 ms

V_{IN} = 3.5 V, C_{IN} = C_L = 1.0 μF, I_{OUT} = 0.1 mA,
 V_{ON/OFF} = 0 V → 3.5 V, t_r = 1.0 μs

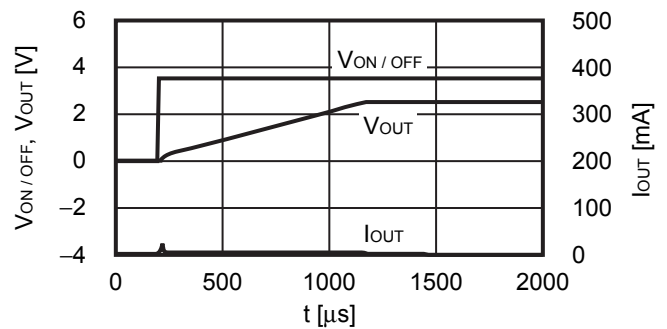

4.3 V_{OUT} = 3.6 V

4.3.1 t_{SS} = 0.1 ms

V_{IN} = 4.6 V, C_{IN} = C_L = 1.0 μF, I_{OUT} = 0.1 mA,
 V_{ON/OFF} = 0 V → 4.6 V, t_r = 1.0 μs

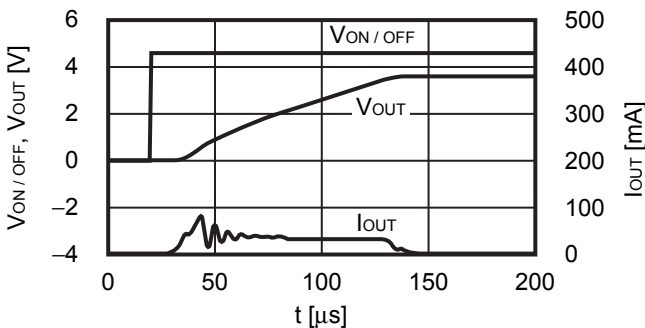

4.3.2 t_{SS} = 1.0 ms

V_{IN} = 4.6 V, C_{IN} = C_L = 1.0 μF, I_{OUT} = 0.1 mA,
 V_{ON/OFF} = 0 V → 4.6 V, t_r = 1.0 μs

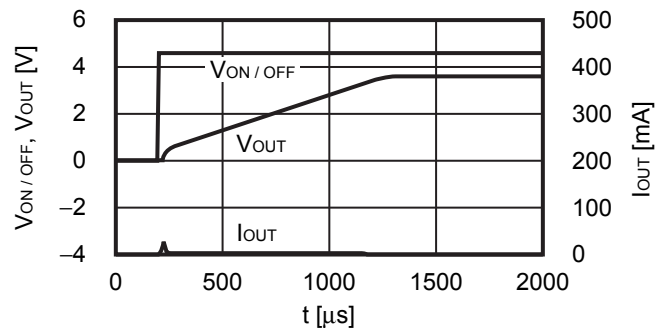

5. Output capacitance vs. Characteristics of discharge time (Ta = +25°C)

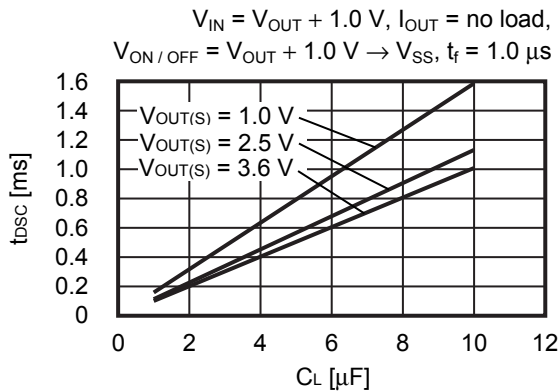

Figure 37 S-1335 Series A / B / E / F / J / K Type (With Discharge Shunt Function)

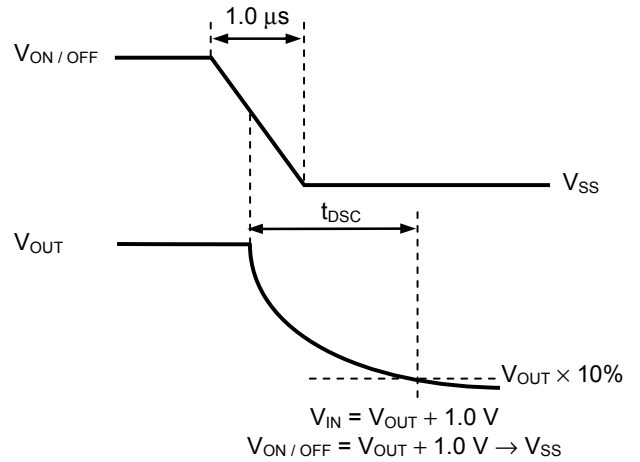

Figure 38 Test Condition of Discharge Time

6. Example of equivalent series resistance vs. Output current characteristics (Ta = +25°C)

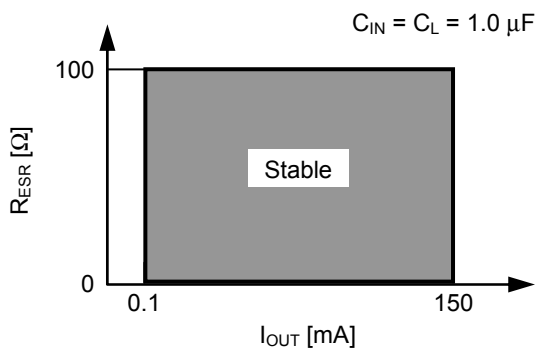
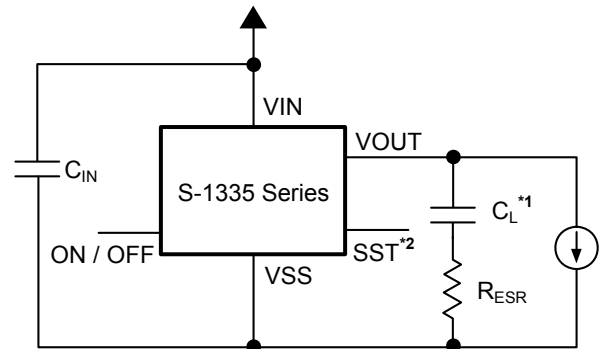

Figure 39



*1. C_L : TDK Corporation C1608X7R1C105K (1.0 μF)

*2. S-1335 Series J / K / L / M type only.

Figure 40

■ **Marking Specifications**

1. SOT-23-5

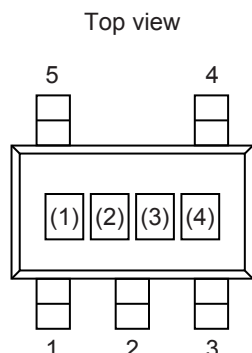

(1) to (3): Product code (Refer to **Product name vs. Product code**)
 (4): Lot number

Product name vs. Product code

1.1 S-1335 Series J type

Product Name	Product Code		
	(1)	(2)	(3)
S-1335J10-M5T1U3	2	V	A
S-1335J11-M5T1U3	2	V	B
S-1335J12-M5T1U3	2	V	C
S-1335J13-M5T1U3	2	V	D
S-1335J14-M5T1U3	2	V	E
S-1335J15-M5T1U3	2	V	F
S-1335J16-M5T1U3	2	V	G
S-1335J17-M5T1U3	2	V	H
S-1335J18-M5T1U3	2	V	J
S-1335J19-M5T1U3	2	V	K
S-1335J20-M5T1U3	2	V	L
S-1335J21-M5T1U3	2	V	N
S-1335J22-M5T1U3	2	V	O
S-1335J23-M5T1U3	2	V	P
S-1335J24-M5T1U3	2	V	Q
S-1335J25-M5T1U3	2	V	R
S-1335J26-M5T1U3	2	V	S
S-1335J27-M5T1U3	2	V	T
S-1335J28-M5T1U3	2	V	U
S-1335J2J-M5T1U3	2	V	7
S-1335J29-M5T1U3	2	V	V
S-1335J30-M5T1U3	2	V	X
S-1335J31-M5T1U3	2	V	Y
S-1335J32-M5T1U3	2	V	Z
S-1335J33-M5T1U3	2	V	1
S-1335J34-M5T1U3	2	V	2
S-1335J35-M5T1U3	2	V	3
S-1335J36-M5T1U3	2	V	4

1.2 S-1335 Series K type

Product Name	Product Code		
	(1)	(2)	(3)
S-1335K10-M5T1U3	2	X	A
S-1335K11-M5T1U3	2	X	B
S-1335K12-M5T1U3	2	X	C
S-1335K13-M5T1U3	2	X	D
S-1335K14-M5T1U3	2	X	E
S-1335K15-M5T1U3	2	X	F
S-1335K16-M5T1U3	2	X	G
S-1335K17-M5T1U3	2	X	H
S-1335K18-M5T1U3	2	X	J
S-1335K19-M5T1U3	2	X	K
S-1335K20-M5T1U3	2	X	L
S-1335K21-M5T1U3	2	X	N
S-1335K22-M5T1U3	2	X	O
S-1335K23-M5T1U3	2	X	P
S-1335K24-M5T1U3	2	X	Q
S-1335K25-M5T1U3	2	X	R
S-1335K26-M5T1U3	2	X	S
S-1335K27-M5T1U3	2	X	T
S-1335K28-M5T1U3	2	X	U
S-1335K2J-M5T1U3	2	X	7
S-1335K29-M5T1U3	2	X	V
S-1335K30-M5T1U3	2	X	X
S-1335K31-M5T1U3	2	X	Y
S-1335K32-M5T1U3	2	X	Z
S-1335K33-M5T1U3	2	X	1
S-1335K34-M5T1U3	2	X	2
S-1335K35-M5T1U3	2	X	3
S-1335K36-M5T1U3	2	X	4

HIGH RIPPLE-REJECTION SOFT-START FUNCTION CMOS VOLTAGE REGULATOR

Rev.1.3_00

S-1335 Series

1.3 S-1335 Series L type

Product Name	Product Code		
	(1)	(2)	(3)
S-1335L10-M5T1U3	2	Y	A
S-1335L11-M5T1U3	2	Y	B
S-1335L12-M5T1U3	2	Y	C
S-1335L13-M5T1U3	2	Y	D
S-1335L14-M5T1U3	2	Y	E
S-1335L15-M5T1U3	2	Y	F
S-1335L16-M5T1U3	2	Y	G
S-1335L17-M5T1U3	2	Y	H
S-1335L18-M5T1U3	2	Y	J
S-1335L19-M5T1U3	2	Y	K
S-1335L20-M5T1U3	2	Y	L
S-1335L21-M5T1U3	2	Y	N
S-1335L22-M5T1U3	2	Y	O
S-1335L23-M5T1U3	2	Y	P
S-1335L24-M5T1U3	2	Y	Q
S-1335L25-M5T1U3	2	Y	R
S-1335L26-M5T1U3	2	Y	S
S-1335L27-M5T1U3	2	Y	T
S-1335L28-M5T1U3	2	Y	U
S-1335L2J-M5T1U3	2	Y	7
S-1335L29-M5T1U3	2	Y	V
S-1335L30-M5T1U3	2	Y	X
S-1335L31-M5T1U3	2	Y	Y
S-1335L32-M5T1U3	2	Y	Z
S-1335L33-M5T1U3	2	Y	1
S-1335L34-M5T1U3	2	Y	2
S-1335L35-M5T1U3	2	Y	3
S-1335L36-M5T1U3	2	Y	4

1.4 S-1335 Series M type

Product Name	Product Code		
	(1)	(2)	(3)
S-1335M10-M5T1U3	2	Z	A
S-1335M11-M5T1U3	2	Z	B
S-1335M12-M5T1U3	2	Z	C
S-1335M13-M5T1U3	2	Z	D
S-1335M14-M5T1U3	2	Z	E
S-1335M15-M5T1U3	2	Z	F
S-1335M16-M5T1U3	2	Z	G
S-1335M17-M5T1U3	2	Z	H
S-1335M18-M5T1U3	2	Z	J
S-1335M19-M5T1U3	2	Z	K
S-1335M20-M5T1U3	2	Z	L
S-1335M21-M5T1U3	2	Z	N
S-1335M22-M5T1U3	2	Z	O
S-1335M23-M5T1U3	2	Z	P
S-1335M24-M5T1U3	2	Z	Q
S-1335M25-M5T1U3	2	Z	R
S-1335M26-M5T1U3	2	Z	S
S-1335M27-M5T1U3	2	Z	T
S-1335M28-M5T1U3	2	Z	U
S-1335M2J-M5T1U3	2	Z	7
S-1335M29-M5T1U3	2	Z	V
S-1335M30-M5T1U3	2	Z	X
S-1335M31-M5T1U3	2	Z	Y
S-1335M32-M5T1U3	2	Z	Z
S-1335M33-M5T1U3	2	Z	1
S-1335M34-M5T1U3	2	Z	2
S-1335M35-M5T1U3	2	Z	3
S-1335M36-M5T1U3	2	Z	4

HIGH RIPPLE-REJECTION SOFT-START FUNCTION CMOS VOLTAGE REGULATOR

S-1335 Series

Rev.1.3_00

2. SC-82AB

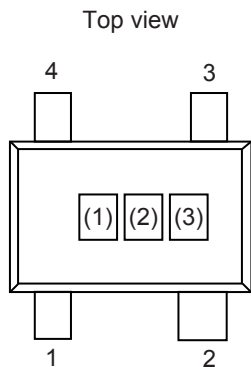

(1) to (3): Product code (Refer to **Product name vs. Product code**)

Product name vs. Product code

2.1 S-1335 Series A type

Product Name	Product Code		
	(1)	(2)	(3)
S-1335A10-N4T1U3	2	5	A
S-1335A11-N4T1U3	2	5	B
S-1335A12-N4T1U3	2	5	C
S-1335A13-N4T1U3	2	5	D
S-1335A14-N4T1U3	2	5	E
S-1335A15-N4T1U3	2	5	F
S-1335A16-N4T1U3	2	5	G
S-1335A17-N4T1U3	2	5	H
S-1335A18-N4T1U3	2	5	J
S-1335A19-N4T1U3	2	5	K
S-1335A20-N4T1U3	2	5	L
S-1335A21-N4T1U3	2	5	N
S-1335A22-N4T1U3	2	5	O
S-1335A23-N4T1U3	2	5	P
S-1335A24-N4T1U3	2	5	Q
S-1335A25-N4T1U3	2	5	R
S-1335A26-N4T1U3	2	5	S
S-1335A27-N4T1U3	2	5	T
S-1335A28-N4T1U3	2	5	U
S-1335A2J-N4T1U3	2	5	7
S-1335A29-N4T1U3	2	5	V
S-1335A30-N4T1U3	2	5	X
S-1335A31-N4T1U3	2	5	Y
S-1335A32-N4T1U3	2	5	Z
S-1335A33-N4T1U3	2	5	1
S-1335A34-N4T1U3	2	5	2
S-1335A35-N4T1U3	2	5	3
S-1335A36-N4T1U3	2	5	4

2.2 S-1335 Series B type

Product Name	Product Code		
	(1)	(2)	(3)
S-1335B10-N4T1U3	2	6	A
S-1335B11-N4T1U3	2	6	B
S-1335B12-N4T1U3	2	6	C
S-1335B13-N4T1U3	2	6	D
S-1335B14-N4T1U3	2	6	E
S-1335B15-N4T1U3	2	6	F
S-1335B16-N4T1U3	2	6	G
S-1335B17-N4T1U3	2	6	H
S-1335B18-N4T1U3	2	6	J
S-1335B19-N4T1U3	2	6	K
S-1335B20-N4T1U3	2	6	L
S-1335B21-N4T1U3	2	6	N
S-1335B22-N4T1U3	2	6	O
S-1335B23-N4T1U3	2	6	P
S-1335B24-N4T1U3	2	6	Q
S-1335B25-N4T1U3	2	6	R
S-1335B26-N4T1U3	2	6	S
S-1335B27-N4T1U3	2	6	T
S-1335B28-N4T1U3	2	6	U
S-1335B2J-N4T1U3	2	6	7
S-1335B29-N4T1U3	2	6	V
S-1335B30-N4T1U3	2	6	X
S-1335B31-N4T1U3	2	6	Y
S-1335B32-N4T1U3	2	6	Z
S-1335B33-N4T1U3	2	6	1
S-1335B34-N4T1U3	2	6	2
S-1335B35-N4T1U3	2	6	3
S-1335B36-N4T1U3	2	6	4

HIGH RIPPLE-REJECTION SOFT-START FUNCTION CMOS VOLTAGE REGULATOR

Rev.1.3_00

S-1335 Series

2.3 S-1335 Series C type

Product Name	Product Code		
	(1)	(2)	(3)
S-1335C10-N4T1U3	2	7	A
S-1335C11-N4T1U3	2	7	B
S-1335C12-N4T1U3	2	7	C
S-1335C13-N4T1U3	2	7	D
S-1335C14-N4T1U3	2	7	E
S-1335C15-N4T1U3	2	7	F
S-1335C16-N4T1U3	2	7	G
S-1335C17-N4T1U3	2	7	H
S-1335C18-N4T1U3	2	7	J
S-1335C19-N4T1U3	2	7	K
S-1335C20-N4T1U3	2	7	L
S-1335C21-N4T1U3	2	7	N
S-1335C22-N4T1U3	2	7	O
S-1335C23-N4T1U3	2	7	P
S-1335C24-N4T1U3	2	7	Q
S-1335C25-N4T1U3	2	7	R
S-1335C26-N4T1U3	2	7	S
S-1335C27-N4T1U3	2	7	T
S-1335C28-N4T1U3	2	7	U
S-1335C2J-N4T1U3	2	7	7
S-1335C29-N4T1U3	2	7	V
S-1335C30-N4T1U3	2	7	X
S-1335C31-N4T1U3	2	7	Y
S-1335C32-N4T1U3	2	7	Z
S-1335C33-N4T1U3	2	7	1
S-1335C34-N4T1U3	2	7	2
S-1335C35-N4T1U3	2	7	3
S-1335C36-N4T1U3	2	7	4

2.4 S-1335 Series D type

Product Name	Product Code		
	(1)	(2)	(3)
S-1335D10-N4T1U3	2	8	A
S-1335D11-N4T1U3	2	8	B
S-1335D12-N4T1U3	2	8	C
S-1335D13-N4T1U3	2	8	D
S-1335D14-N4T1U3	2	8	E
S-1335D15-N4T1U3	2	8	F
S-1335D16-N4T1U3	2	8	G
S-1335D17-N4T1U3	2	8	H
S-1335D18-N4T1U3	2	8	J
S-1335D19-N4T1U3	2	8	K
S-1335D20-N4T1U3	2	8	L
S-1335D21-N4T1U3	2	8	N
S-1335D22-N4T1U3	2	8	O
S-1335D23-N4T1U3	2	8	P
S-1335D24-N4T1U3	2	8	Q
S-1335D25-N4T1U3	2	8	R
S-1335D26-N4T1U3	2	8	S
S-1335D27-N4T1U3	2	8	T
S-1335D28-N4T1U3	2	8	U
S-1335D2J-N4T1U3	2	8	7
S-1335D29-N4T1U3	2	8	V
S-1335D30-N4T1U3	2	8	X
S-1335D31-N4T1U3	2	8	Y
S-1335D32-N4T1U3	2	8	Z
S-1335D33-N4T1U3	2	8	1
S-1335D34-N4T1U3	2	8	2
S-1335D35-N4T1U3	2	8	3
S-1335D36-N4T1U3	2	8	4

HIGH RIPPLE-REJECTION SOFT-START FUNCTION CMOS VOLTAGE REGULATOR

S-1335 Series

Rev.1.3_00

3. HSNT-4 (1010)

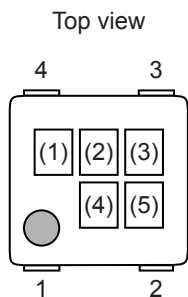

(1) to (3): Product code (Refer to **Product name vs. Product code**)
 (4), (5): Lot number

Product name vs. Product code

3.1 S-1335 Series A type

Product Name	Product Code		
	(1)	(2)	(3)
S-1335A10-A4T2U3	2	5	A
S-1335A11-A4T2U3	2	5	B
S-1335A12-A4T2U3	2	5	C
S-1335A13-A4T2U3	2	5	D
S-1335A14-A4T2U3	2	5	E
S-1335A15-A4T2U3	2	5	F
S-1335A16-A4T2U3	2	5	G
S-1335A17-A4T2U3	2	5	H
S-1335A18-A4T2U3	2	5	J
S-1335A19-A4T2U3	2	5	K
S-1335A20-A4T2U3	2	5	L
S-1335A21-A4T2U3	2	5	N
S-1335A22-A4T2U3	2	5	O
S-1335A23-A4T2U3	2	5	P
S-1335A24-A4T2U3	2	5	Q
S-1335A25-A4T2U3	2	5	R
S-1335A26-A4T2U3	2	5	S
S-1335A27-A4T2U3	2	5	T
S-1335A28-A4T2U3	2	5	U
S-1335A2J-A4T2U3	2	5	7
S-1335A29-A4T2U3	2	5	V
S-1335A30-A4T2U3	2	5	X
S-1335A31-A4T2U3	2	5	Y
S-1335A32-A4T2U3	2	5	Z
S-1335A33-A4T2U3	2	5	1
S-1335A34-A4T2U3	2	5	2
S-1335A35-A4T2U3	2	5	3
S-1335A36-A4T2U3	2	5	4

3.2 S-1335 Series B type

Product Name	Product Code		
	(1)	(2)	(3)
S-1335B10-A4T2U3	2	6	A
S-1335B11-A4T2U3	2	6	B
S-1335B12-A4T2U3	2	6	C
S-1335B13-A4T2U3	2	6	D
S-1335B14-A4T2U3	2	6	E
S-1335B15-A4T2U3	2	6	F
S-1335B16-A4T2U3	2	6	G
S-1335B17-A4T2U3	2	6	H
S-1335B18-A4T2U3	2	6	J
S-1335B19-A4T2U3	2	6	K
S-1335B20-A4T2U3	2	6	L
S-1335B21-A4T2U3	2	6	N
S-1335B22-A4T2U3	2	6	O
S-1335B23-A4T2U3	2	6	P
S-1335B24-A4T2U3	2	6	Q
S-1335B25-A4T2U3	2	6	R
S-1335B26-A4T2U3	2	6	S
S-1335B27-A4T2U3	2	6	T
S-1335B28-A4T2U3	2	6	U
S-1335B2J-A4T2U3	2	6	7
S-1335B29-A4T2U3	2	6	V
S-1335B30-A4T2U3	2	6	X
S-1335B31-A4T2U3	2	6	Y
S-1335B32-A4T2U3	2	6	Z
S-1335B33-A4T2U3	2	6	1
S-1335B34-A4T2U3	2	6	2
S-1335B35-A4T2U3	2	6	3
S-1335B36-A4T2U3	2	6	4

HIGH RIPPLE-REJECTION SOFT-START FUNCTION CMOS VOLTAGE REGULATOR

Rev.1.3_00

S-1335 Series

3.3 S-1335 Series C type

Product Name	Product Code		
	(1)	(2)	(3)
S-1335C10-A4T2U3	2	7	A
S-1335C11-A4T2U3	2	7	B
S-1335C12-A4T2U3	2	7	C
S-1335C13-A4T2U3	2	7	D
S-1335C14-A4T2U3	2	7	E
S-1335C15-A4T2U3	2	7	F
S-1335C16-A4T2U3	2	7	G
S-1335C17-A4T2U3	2	7	H
S-1335C18-A4T2U3	2	7	J
S-1335C19-A4T2U3	2	7	K
S-1335C20-A4T2U3	2	7	L
S-1335C21-A4T2U3	2	7	N
S-1335C22-A4T2U3	2	7	O
S-1335C23-A4T2U3	2	7	P
S-1335C24-A4T2U3	2	7	Q
S-1335C25-A4T2U3	2	7	R
S-1335C26-A4T2U3	2	7	S
S-1335C27-A4T2U3	2	7	T
S-1335C28-A4T2U3	2	7	U
S-1335C2J-A4T2U3	2	7	7
S-1335C29-A4T2U3	2	7	V
S-1335C30-A4T2U3	2	7	X
S-1335C31-A4T2U3	2	7	Y
S-1335C32-A4T2U3	2	7	Z
S-1335C33-A4T2U3	2	7	1
S-1335C34-A4T2U3	2	7	2
S-1335C35-A4T2U3	2	7	3
S-1335C36-A4T2U3	2	7	4

3.4 S-1335 Series D type

Product Name	Product Code		
	(1)	(2)	(3)
S-1335D10-A4T2U3	2	8	A
S-1335D11-A4T2U3	2	8	B
S-1335D12-A4T2U3	2	8	C
S-1335D13-A4T2U3	2	8	D
S-1335D14-A4T2U3	2	8	E
S-1335D15-A4T2U3	2	8	F
S-1335D16-A4T2U3	2	8	G
S-1335D17-A4T2U3	2	8	H
S-1335D18-A4T2U3	2	8	J
S-1335D19-A4T2U3	2	8	K
S-1335D20-A4T2U3	2	8	L
S-1335D21-A4T2U3	2	8	N
S-1335D22-A4T2U3	2	8	O
S-1335D23-A4T2U3	2	8	P
S-1335D24-A4T2U3	2	8	Q
S-1335D25-A4T2U3	2	8	R
S-1335D26-A4T2U3	2	8	S
S-1335D27-A4T2U3	2	8	T
S-1335D28-A4T2U3	2	8	U
S-1335D2J-A4T2U3	2	8	7
S-1335D29-A4T2U3	2	8	V
S-1335D30-A4T2U3	2	8	X
S-1335D31-A4T2U3	2	8	Y
S-1335D32-A4T2U3	2	8	Z
S-1335D33-A4T2U3	2	8	1
S-1335D34-A4T2U3	2	8	2
S-1335D35-A4T2U3	2	8	3
S-1335D36-A4T2U3	2	8	4

HIGH RIPPLE-REJECTION SOFT-START FUNCTION CMOS VOLTAGE REGULATOR

S-1335 Series

Rev.1.3_00

3.5 S-1335 Series E type

Product Name	Product Code		
	(1)	(2)	(3)
S-1335E10-A4T2U3	2	1	A
S-1335E11-A4T2U3	2	1	B
S-1335E12-A4T2U3	2	1	C
S-1335E13-A4T2U3	2	1	D
S-1335E14-A4T2U3	2	1	E
S-1335E15-A4T2U3	2	1	F
S-1335E16-A4T2U3	2	1	G
S-1335E17-A4T2U3	2	1	H
S-1335E18-A4T2U3	2	1	J
S-1335E19-A4T2U3	2	1	K
S-1335E20-A4T2U3	2	1	L
S-1335E21-A4T2U3	2	1	N
S-1335E22-A4T2U3	2	1	O
S-1335E23-A4T2U3	2	1	P
S-1335E24-A4T2U3	2	1	Q
S-1335E25-A4T2U3	2	1	R
S-1335E26-A4T2U3	2	1	S
S-1335E27-A4T2U3	2	1	T
S-1335E28-A4T2U3	2	1	U
S-1335E2J-A4T2U3	2	1	7
S-1335E29-A4T2U3	2	1	V
S-1335E30-A4T2U3	2	1	X
S-1335E31-A4T2U3	2	1	Y
S-1335E32-A4T2U3	2	1	Z
S-1335E33-A4T2U3	2	1	1
S-1335E34-A4T2U3	2	1	2
S-1335E35-A4T2U3	2	1	3
S-1335E36-A4T2U3	2	1	4

3.6 S-1335 Series F type

Product Name	Product Code		
	(1)	(2)	(3)
S-1335F10-A4T2U3	2	2	A
S-1335F11-A4T2U3	2	2	B
S-1335F12-A4T2U3	2	2	C
S-1335F13-A4T2U3	2	2	D
S-1335F14-A4T2U3	2	2	E
S-1335F15-A4T2U3	2	2	F
S-1335F16-A4T2U3	2	2	G
S-1335F17-A4T2U3	2	2	H
S-1335F18-A4T2U3	2	2	J
S-1335F19-A4T2U3	2	2	K
S-1335F20-A4T2U3	2	2	L
S-1335F21-A4T2U3	2	2	N
S-1335F22-A4T2U3	2	2	O
S-1335F23-A4T2U3	2	2	P
S-1335F24-A4T2U3	2	2	Q
S-1335F25-A4T2U3	2	2	R
S-1335F26-A4T2U3	2	2	S
S-1335F27-A4T2U3	2	2	T
S-1335F28-A4T2U3	2	2	U
S-1335F2J-A4T2U3	2	2	7
S-1335F29-A4T2U3	2	2	V
S-1335F30-A4T2U3	2	2	X
S-1335F31-A4T2U3	2	2	Y
S-1335F32-A4T2U3	2	2	Z
S-1335F33-A4T2U3	2	2	1
S-1335F34-A4T2U3	2	2	2
S-1335F35-A4T2U3	2	2	3
S-1335F36-A4T2U3	2	2	4

HIGH RIPPLE-REJECTION SOFT-START FUNCTION CMOS VOLTAGE REGULATOR

Rev.1.3_00

S-1335 Series

3.7 S-1335 Series G type

Product Name	Product Code		
	(1)	(2)	(3)
S-1335G10-A4T2U3	2	3	A
S-1335G11-A4T2U3	2	3	B
S-1335G12-A4T2U3	2	3	C
S-1335G13-A4T2U3	2	3	D
S-1335G14-A4T2U3	2	3	E
S-1335G15-A4T2U3	2	3	F
S-1335G16-A4T2U3	2	3	G
S-1335G17-A4T2U3	2	3	H
S-1335G18-A4T2U3	2	3	J
S-1335G19-A4T2U3	2	3	K
S-1335G20-A4T2U3	2	3	L
S-1335G21-A4T2U3	2	3	N
S-1335G22-A4T2U3	2	3	O
S-1335G23-A4T2U3	2	3	P
S-1335G24-A4T2U3	2	3	Q
S-1335G25-A4T2U3	2	3	R
S-1335G26-A4T2U3	2	3	S
S-1335G27-A4T2U3	2	3	T
S-1335G28-A4T2U3	2	3	U
S-1335G2J-A4T2U3	2	3	7
S-1335G29-A4T2U3	2	3	V
S-1335G30-A4T2U3	2	3	X
S-1335G31-A4T2U3	2	3	Y
S-1335G32-A4T2U3	2	3	Z
S-1335G33-A4T2U3	2	3	1
S-1335G34-A4T2U3	2	3	2
S-1335G35-A4T2U3	2	3	3
S-1335G36-A4T2U3	2	3	4

3.8 S-1335 Series H type

Product Name	Product Code		
	(1)	(2)	(3)
S-1335H10-A4T2U3	2	9	A
S-1335H11-A4T2U3	2	9	B
S-1335H12-A4T2U3	2	9	C
S-1335H13-A4T2U3	2	9	D
S-1335H14-A4T2U3	2	9	E
S-1335H15-A4T2U3	2	9	F
S-1335H16-A4T2U3	2	9	G
S-1335H17-A4T2U3	2	9	H
S-1335H18-A4T2U3	2	9	J
S-1335H19-A4T2U3	2	9	K
S-1335H20-A4T2U3	2	9	L
S-1335H21-A4T2U3	2	9	N
S-1335H22-A4T2U3	2	9	O
S-1335H23-A4T2U3	2	9	P
S-1335H24-A4T2U3	2	9	Q
S-1335H25-A4T2U3	2	9	R
S-1335H26-A4T2U3	2	9	S
S-1335H27-A4T2U3	2	9	T
S-1335H28-A4T2U3	2	9	U
S-1335H2J-A4T2U3	2	9	7
S-1335H29-A4T2U3	2	9	V
S-1335H30-A4T2U3	2	9	X
S-1335H31-A4T2U3	2	9	Y
S-1335H32-A4T2U3	2	9	Z
S-1335H33-A4T2U3	2	9	1
S-1335H34-A4T2U3	2	9	2
S-1335H35-A4T2U3	2	9	3
S-1335H36-A4T2U3	2	9	4

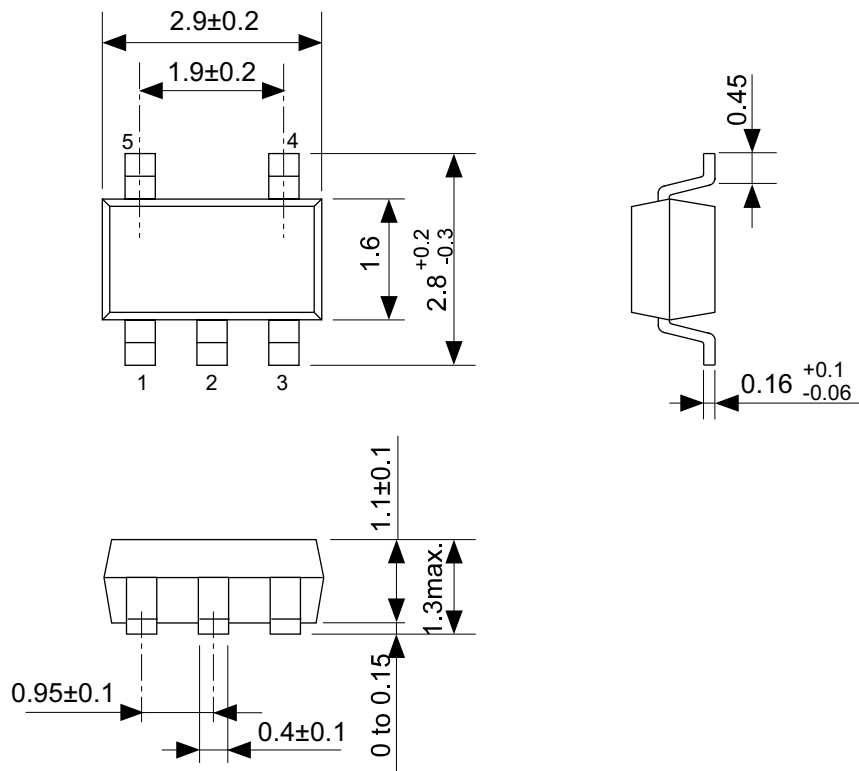

No. MP005-A-P-SD-1.2

TITLE	SOT235-A-PKG Dimensions
No.	MP005-A-P-SD-1.2
SCALE	
UNIT	mm
Seiko Instruments Inc.	

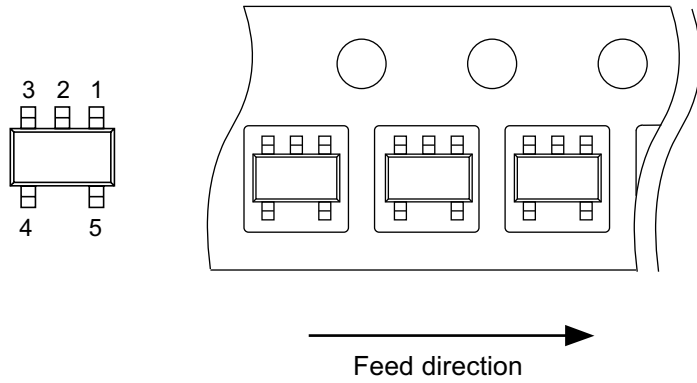
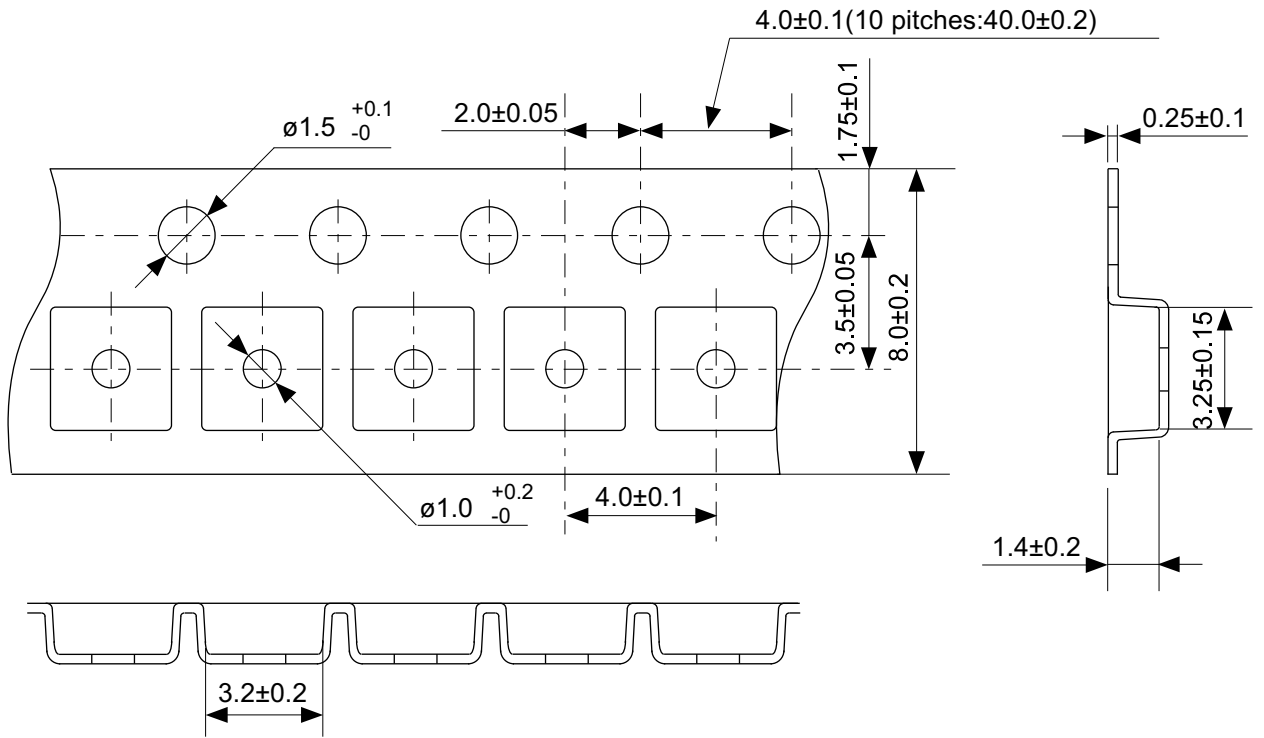

No. MP005-A-C-SD-2.1

TITLE	SOT235-A-Carrier Tape
No.	MP005-A-C-SD-2.1
SCALE	
UNIT	mm
Seiko Instruments Inc.	

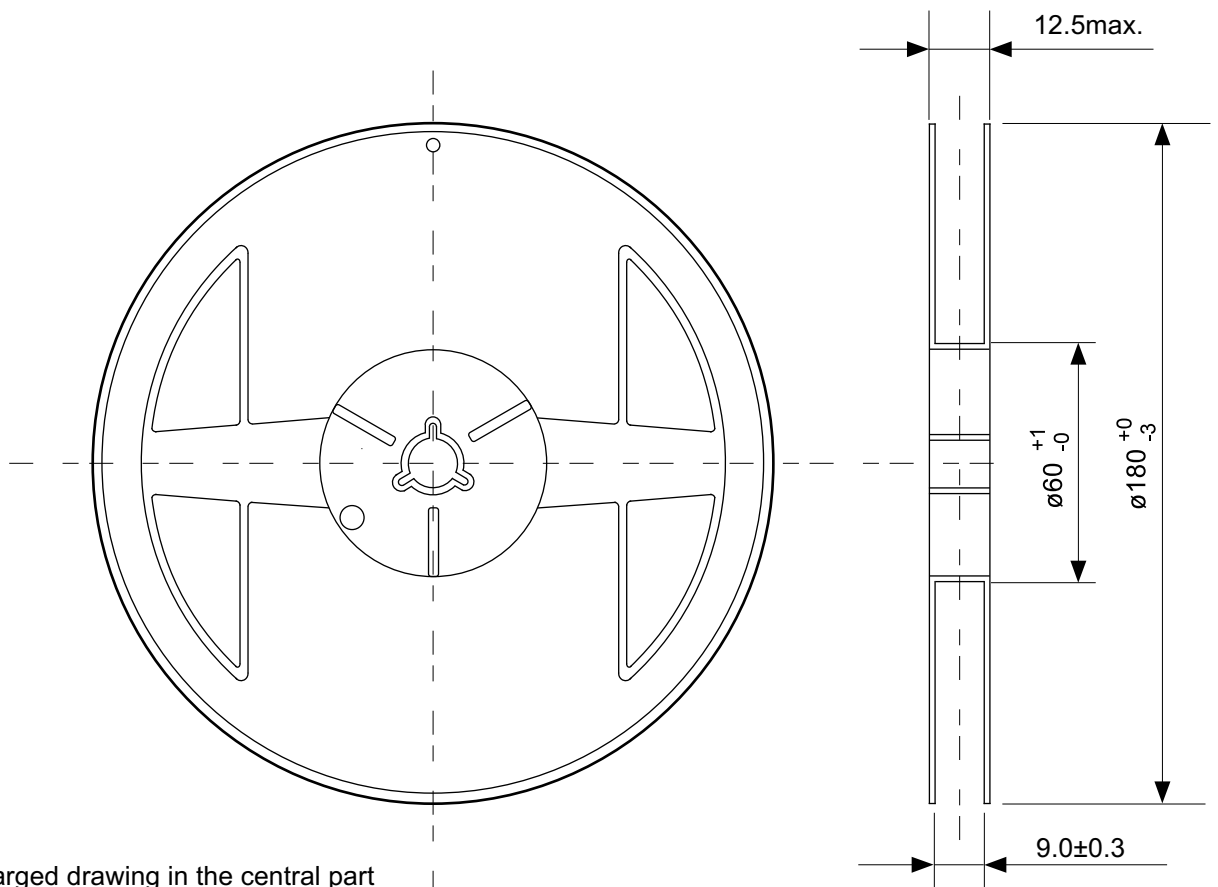

Enlarged drawing in the central part

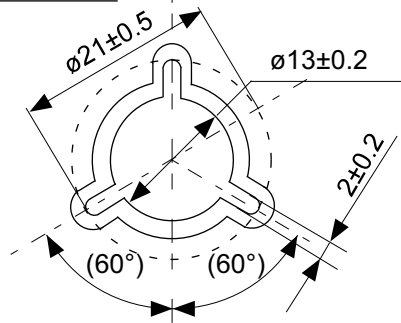

No. MP005-A-R-SD-1.1

TITLE	SOT235-A-Reel		
No.	MP005-A-R-SD-1.1		
SCALE		QTY.	3,000
UNIT	mm		
Seiko Instruments Inc.			

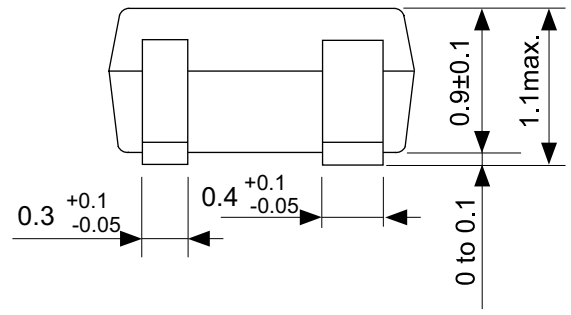
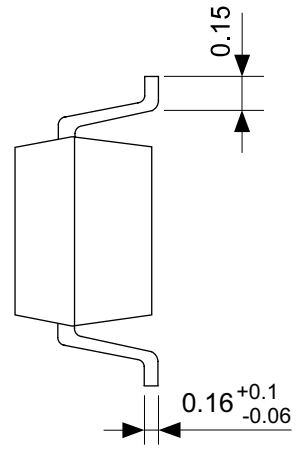
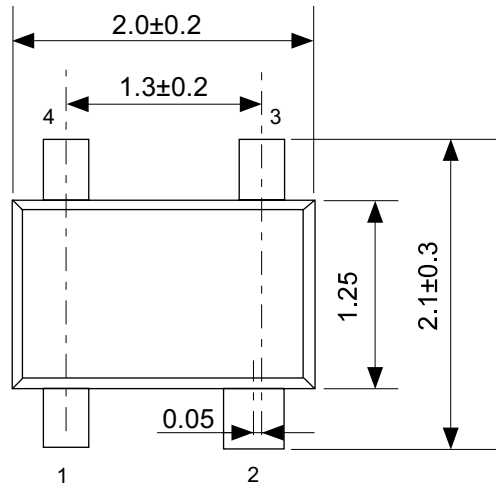

No. NP004-A-P-SD-1.1

TITLE	SC82AB-A-PKG Dimensions
No.	NP004-A-P-SD-1.1
SCALE	
UNIT	mm
Seiko Instruments Inc.	

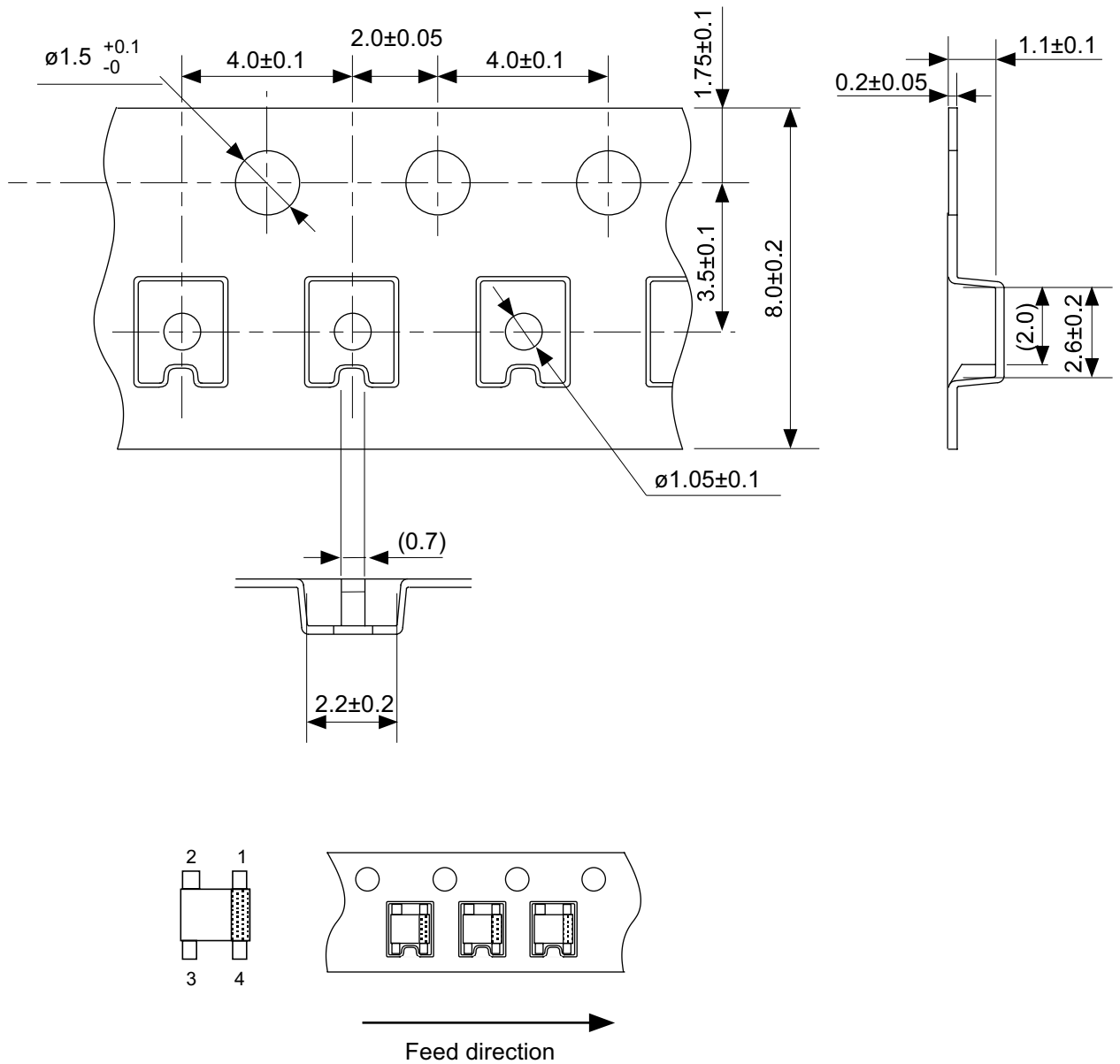

No. NP004-A-C-SD-3.0

TITLE	SC82AB-A-Carrier Tape
No.	NP004-A-C-SD-3.0
SCALE	
UNIT	mm
Seiko Instruments Inc.	

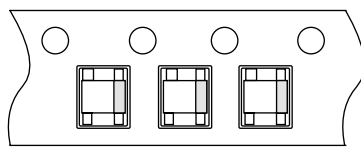
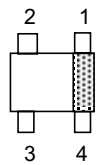
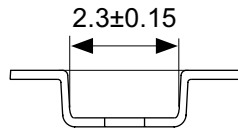
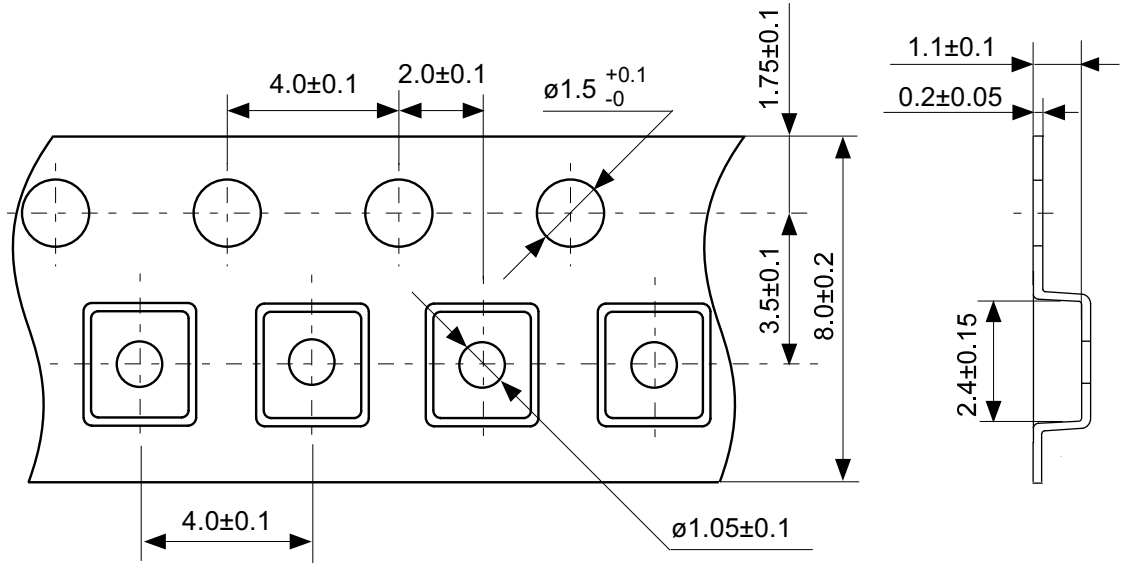

Feed direction

No. NP004-A-C-S1-2.0

TITLE	SC82AB-A-Carrier Tape
No.	NP004-A-C-S1-2.0
SCALE	
UNIT	mm

Seiko Instruments Inc.

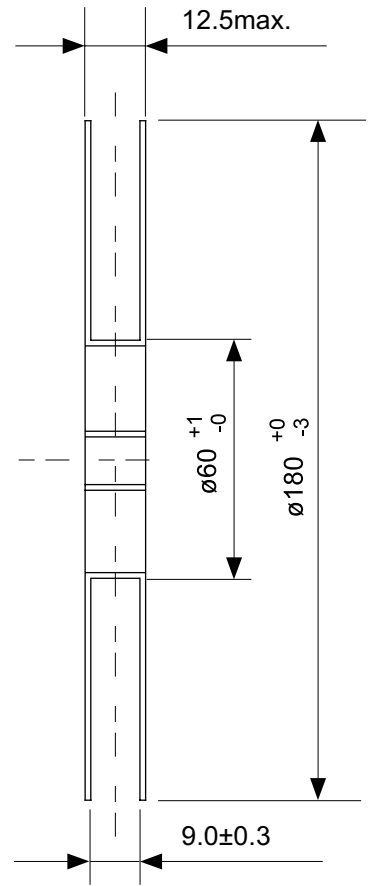
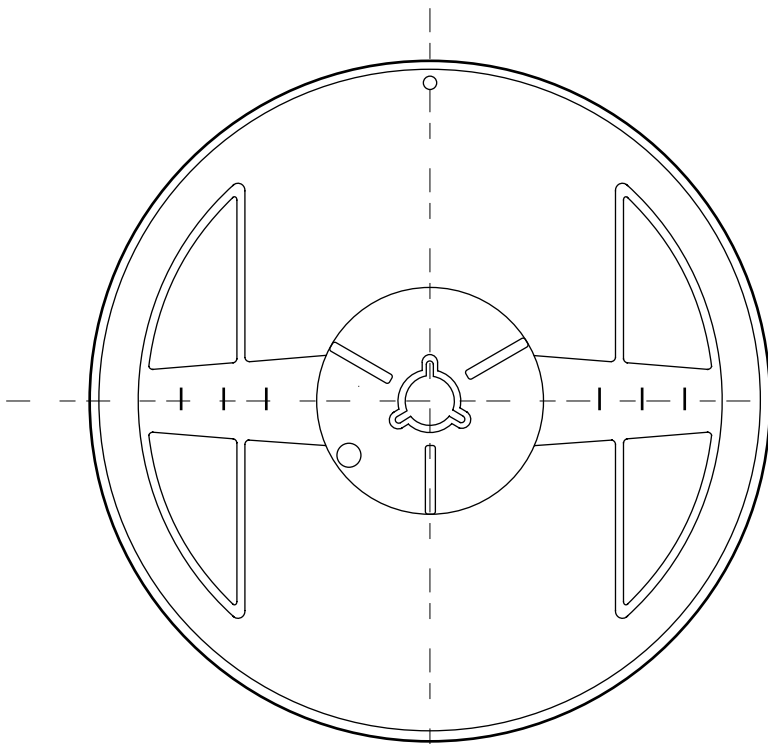

Enlarged drawing in the central part

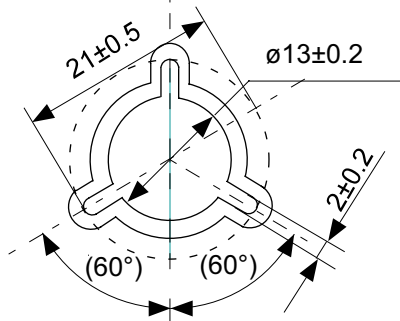

No. NP004-A-R-SD-1.1

TITLE	SC82AB-A-Reel		
No.	NP004-A-R-SD-1.1		
SCALE		QTY.	3,000
UNIT	mm		
Seiko Instruments Inc.			

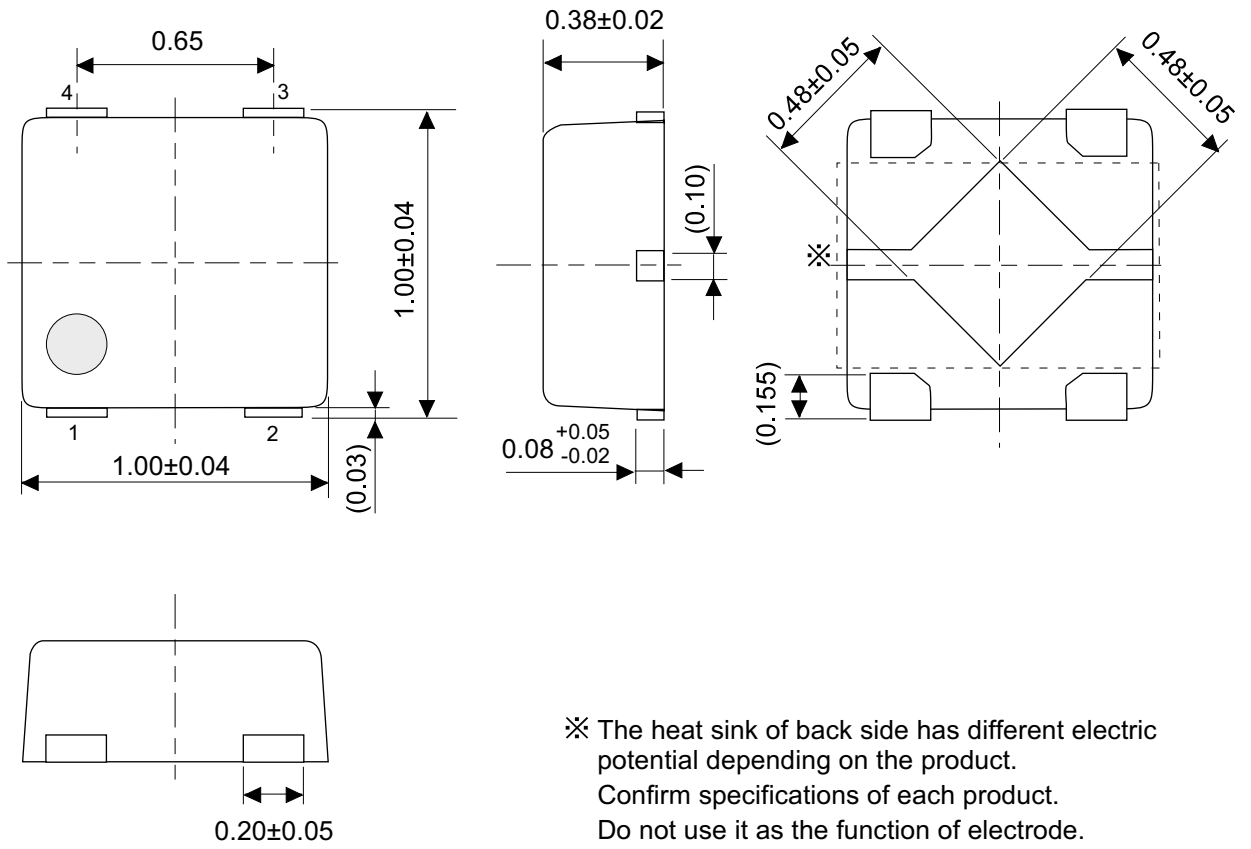

No. PL004-A-P-SD-1.0

TITLE	HSNT-4-B-PKG Dimensions
No.	PL004-A-P-SD-1.0
SCALE	
UNIT	mm
Seiko Instruments Inc.	

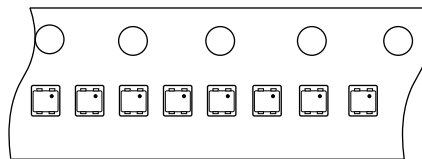
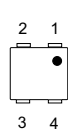
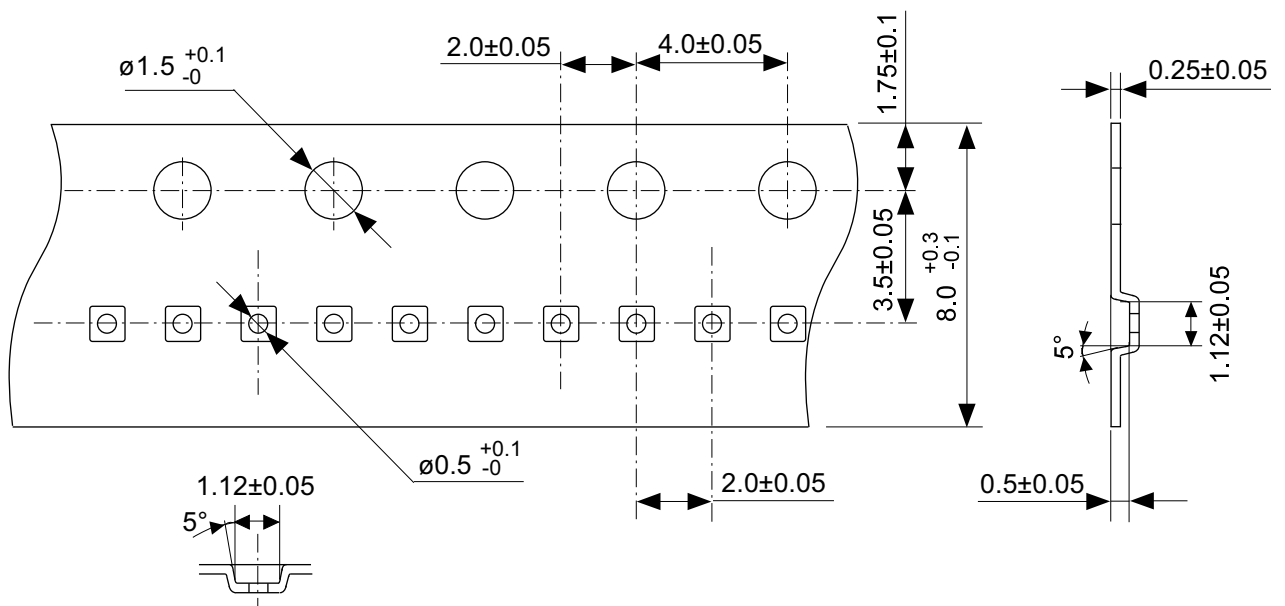

Feed direction →

No. PL004-A-C-SD-1.0

TITLE	HSNT-4-B-Carrier Tape
No.	PL004-A-C-SD-1.0
SCALE	
UNIT	mm
Seiko Instruments Inc.	

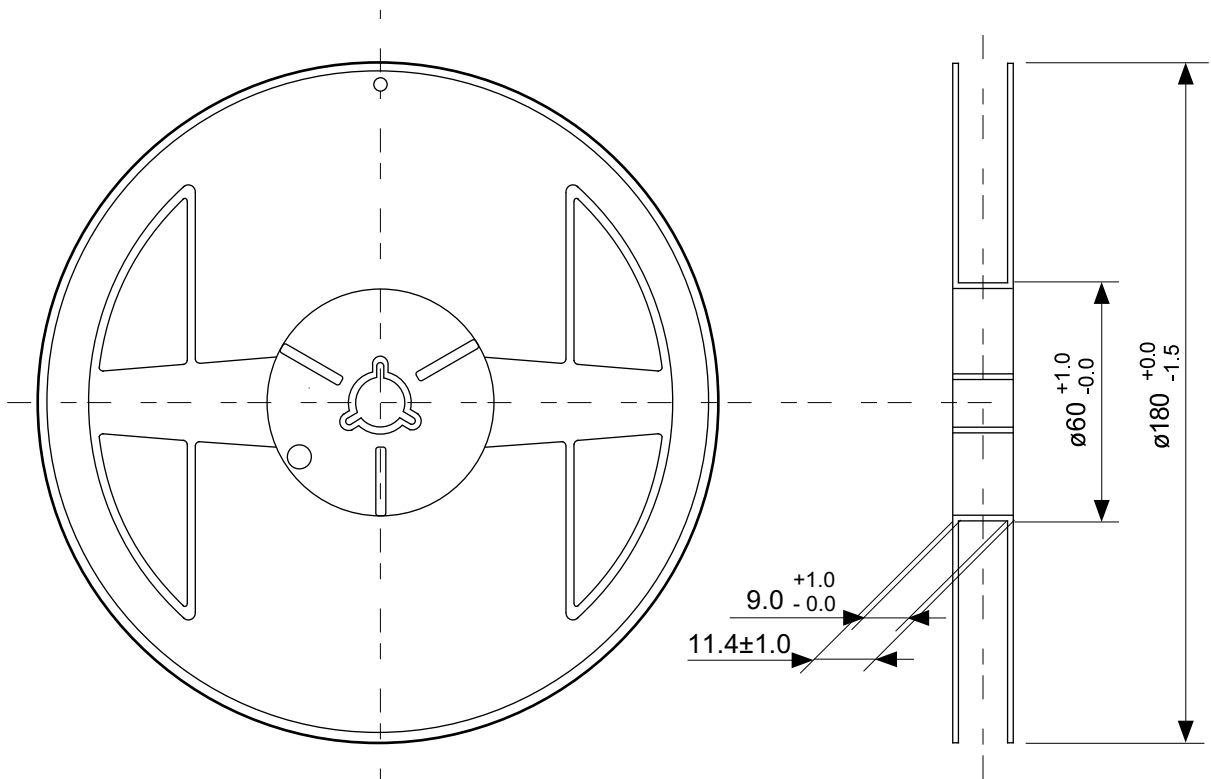

Enlarged drawing in the central part

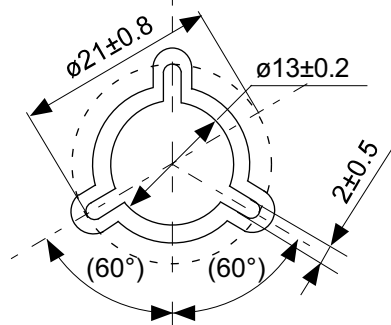

No. PL004-A-R-SD-1.0

TITLE	HSNT-4-B-Reel		
No.	PL004-A-R-SD-1.0		
SCALE		QTY.	10,000
UNIT	mm		
Seiko Instruments Inc.			



Seiko Instruments Inc.
www.sii-ic.com

- The information described herein is subject to change without notice.
- Seiko Instruments Inc. is not responsible for any problems caused by circuits or diagrams described herein whose related industrial properties, patents, or other rights belong to third parties. The application circuit examples explain typical applications of the products, and do not guarantee the success of any specific mass-production design.
- When the products described herein are regulated products subject to the Wassenaar Arrangement or other agreements, they may not be exported without authorization from the appropriate governmental authority.
- Use of the information described herein for other purposes and/or reproduction or copying without the express permission of Seiko Instruments Inc. is strictly prohibited.
- The products described herein cannot be used as part of any device or equipment affecting the human body, such as exercise equipment, medical equipment, security systems, gas equipment, vehicle equipment, in-vehicle equipment, aviation equipment, aerospace equipment, and nuclear-related equipment, without prior written permission of Seiko Instruments Inc.
- The products described herein are not designed to be radiation-proof.
- Although Seiko Instruments Inc. exerts the greatest possible effort to ensure high quality and reliability, the failure or malfunction of semiconductor products may occur. The user of these products should therefore give thorough consideration to safety design, including redundancy, fire-prevention measures, and malfunction prevention, to prevent any accidents, fires, or community damage that may ensue.