

Contents

Features 1
Applications 1
Dimensions (100-pin SQFP)..... 2
Pin Assignments..... 2
Pin Function 3
Block Diagram 4
Absolute Maximum Ratings..... 4
Recommended Operating Conditions..... 5
DC Characteristics..... 5

The S-14L05A 4-bit microcomputer integrates ROM, RAM, I/O ports, timers, an LCD driver and a 16-level detection circuit (4-bit A-D converter) on one chip. Since it can operate at 0.9 V, this microcomputer is ideal for systems that operate on single-battery power

■ **Feature**

- Si gate CMOS process
- Operating voltage: 0.9 V to 2.2 V (32 kHz), 1.1 V to 2.2 V (400 kHz)
- Operating frequency (instruction execution time): 32.768 kHz (122 μ s), 76.8 kHz (52 μ s), 400 kHz (10 μ s)
- ROM: 4K \times 16 bits
- RAM: 768 \times 4 bits
- 32 I/O lines
- Serial interface: clock synchronous, 8-bit, one channel
- Programmable timer: 8-bit one channel
- Time-base timer
- Watchdog timer
- 16-level detection circuit
- LCD driver: 4 common (or 3 common), 48 segments, internal constant voltage circuit, voltage booster circuit
- Buzzer signal output circuit with sound volume switch function
- LED display signal output circuit 2 line output of 16.4 kHz signal (at 32.768 kHz)
- Interrupt function: 3 external interrupts, 5 internal interrupts
- Standby function
- Instructions: 37 basic instruction sets (168 including addressing modes)
16-level subroutine nesting
- 100-pin SQFP (Product name: S-14L05AQS-XXX, XXX is ROM code)

■ **Applications**

- Pagers
- Portable information devices

CMOS 4-bit 1-chip MICROCOMPUTER
S-14L05AQS

■ **Dimensions (100-pin SQFP)**

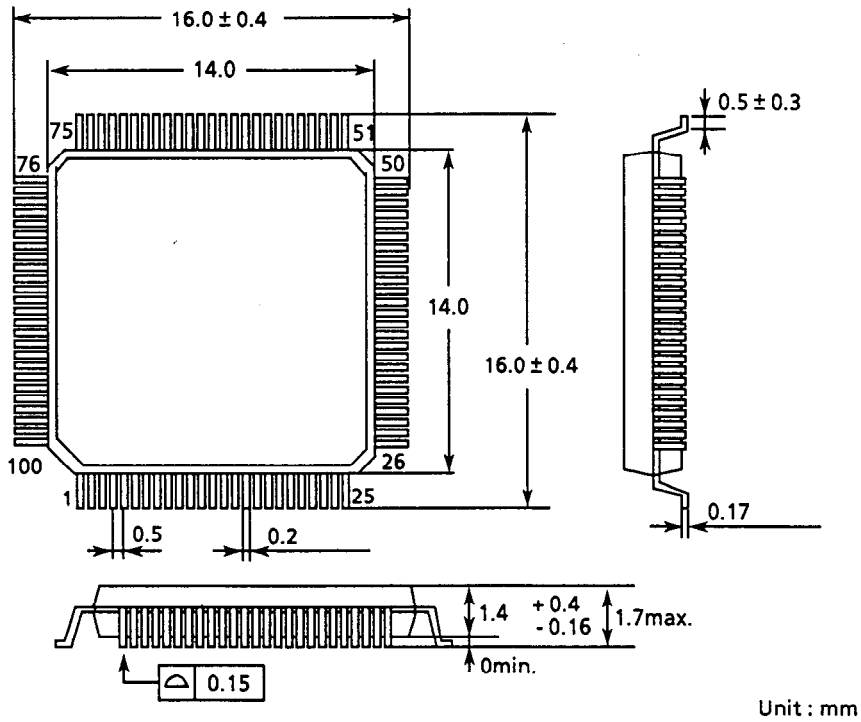

Figure 1

Unit : mm

■ **Pin Assignments**

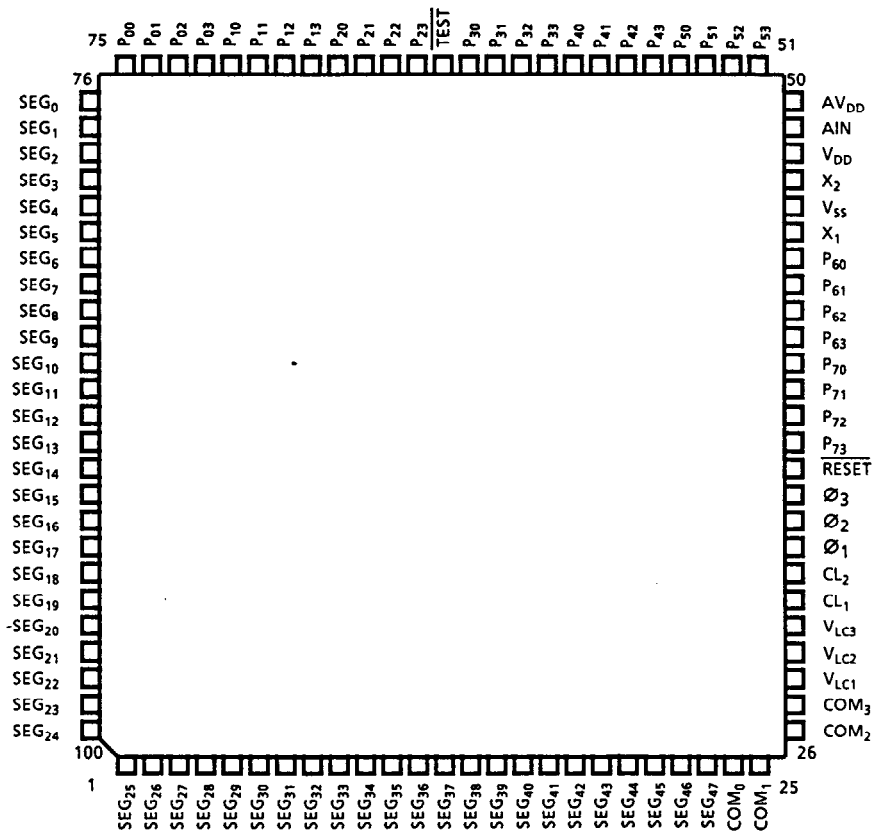

Figure 2

■ Pin Function

Table 1

Pin No.	Pin Name	I/O	Functions	System Reset
46	V _{SS}	—	GND potential terminal	—
48	V _{DD}	—	Positive power supply	—
50	AV _{DD}	—	16-level detection circuit power supply	—
63	$\overline{\text{TEST}}$	Input	Test input (with internal pull-up resistor)	Input
36	$\overline{\text{RESET}}$	Input	Reset input (with internal pull-up resistor)	Input
31	CL ₁	—	Resistor connection pin for main clock CR oscillation	oscillation stop
32	CL ₂	—	Resistor connection pin for main clock CR oscillation	—
45	X ₁	—	Crystal connection for subclock oscillation	oscillation start
47	X ₂	—	Crystal connection for subclock oscillation	—
28 to 30	V _{LC1} to V _{LC3}	—	LCD driver power supply	V _{LC1} = 1.0 V V _{LC2} to V _{LC3} = V _{DD}
33 to 35	∅ ₁ to ∅ ₃	—	Capacitor for LCD driver voltage connection pin	—
24 to 27	COM ₀ to COM ₃	Output	LCD driver common signal output	COM ₀ = V _{SS} COM ₁ to COM ₃ = V _{DD}
76 to 100 1 to 23	SEG ₀ to SEG ₄₇	Output	LCD driver segment signal output	*
49	AIN	Input	16-level detection circuit analog input	Input
75 to 72	P ₀₀ to P ₀₃	Input	Input port P ₀₀ is also used as external interrupt input (at the fall) P ₀₁ is also used as external interrupt input (at the rise)	Input
71 to 68	P ₁₀ to P ₁₃	Input	Input port Also used as key interrupt input	Input
67 to 64	P ₂₀ to P ₂₃	Output	Output port P ₂₀ is also used as buzzer signal output P ₂₁ is also used as time-out signal output P ₂₂ , P ₂₃ are also used as LED display signal output	Output (V _{SS})
62 to 59	P ₃₀ to P ₃₃	Output	Output port	Output (V _{SS})
58 to 55	P ₄₀ to P ₄₃	Output	Output port	Output (V _{SS})
54 to 51	P ₅₀ to P ₅₃	Output	Output port	Output (V _{SS})
44 to 41	P ₆₀ to P ₆₃	I/O	I/O port (input or output selectable for each bit) P ₆₁ , P ₆₂ , P ₆₃ are also used as serial input/output	Input
40 to 37	P ₇₀ to P ₇₃	I/O	I/O port (input or output selectable for each bit)	Input

CMOS 4-bit 1-chip MICROCOMPUTER S-14L05AQS

■ Block Diagram

The S-14L05A blocks are linked by 4-bit data bus (DB), a 4-bit address bus (AB), a 4-bit RAM address bus (RA), and a 12-bit operation bus (OB).

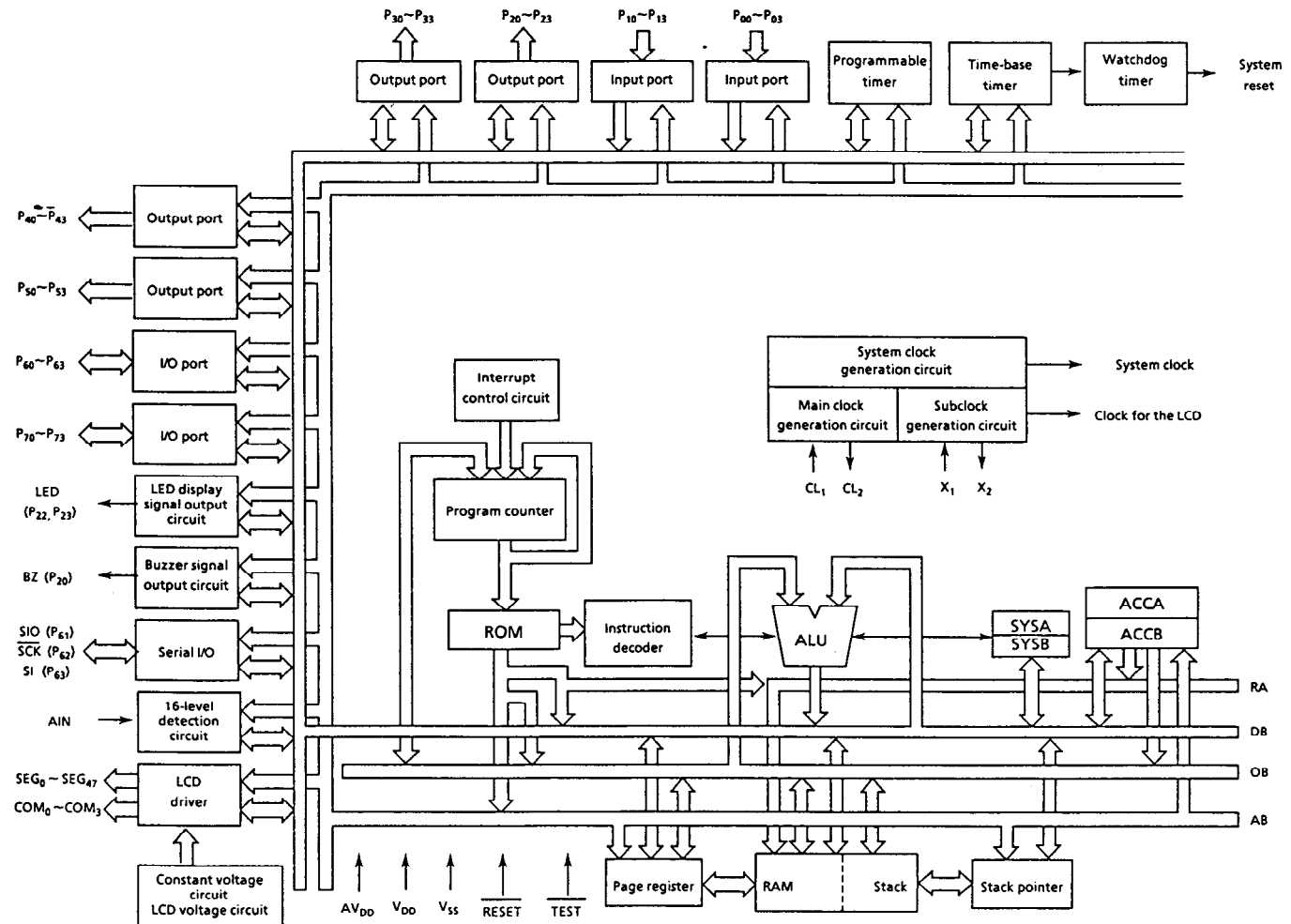

Figure 3

■ Absolute Maximum Ratings

Table 2

Item	Symbol	Conditions	Rating	Unit
Storage temperature	Tstg		-40 to +125	°C
Operating temperature	Topr		-10 to +70	°C
Power supply voltage	V _{DD}	T _a = 25°C	-0.3 to 4.0	V
Input voltage	V _{IN}	T _a = 25°C	V _{SS} -0.3 to V _{CC} + 0.3	V
Output voltage	V _{OUT}	T _a = 25°C	V _{SS} to V _{DD}	V
Power dissipation	P _d	T _a = 25°C	300	mW

■ Recommended Operating Conditions

Table 3

(Ta = -10°C to +70°C)

Item	Symbol	Conditions	Min.	Typ.	Max.	Unit
Power supply voltage1	V _{DD1}	FAST, SLOW, SLEEP mode Main clock: 1 MHz MAX.	1.2	—	2.2	V
Power supply voltage2	V _{DD2}	FAST, SLOW, SLEEP mode Main clock: 400 kHz MAX.	1.1	—	2.2	V
Power supply voltage3	V _{DD3}	SUB, STOP mode Subclock: 76.8 kHz MAX.	0.9	—	2.2	V
Main clock oscillation start power supply voltage	V _{STM1}	Ceramic oscillation: 1 MHz MAX.	1.2	—	2.2	V
Main clock oscillation start power supply voltage	V _{STM2}	CR oscillation: 400 kHz MAX.	1.1	—	2.2	V
Subclock oscillation start power supply voltage	V _{STS}	Crystal oscillation: 32.768 kHz	1.0	—	2.2	V
Main clock frequency	f _{CL}		—	—	1	MHz
Subclock frequency 1	f _{X1}	Internal oscillation	—	32.768	—	kHz
Subclock frequency 2	f _{X2}	External clock input	—	76.8	—	kHz
Input Voltage	V _{IN}		0	—	V _{DD}	V

■ DC Characteristics

Table 4

(V_{DD} = 1.5 V, f_{CL} = 400 kHz, f_X = 32.768 kHz, Ta = -10°C to +70°C)

Item	Symbol	Conditions	Min.	Typ.	Max.	Unit
Current consumption 1*	I _{DD1}	FAST mode, no load, CR oscillation	—	62	110	μA
		FAST mode, no load, ceramic oscillation	—	49	95	
Current consumption 2*	I _{DD2}	SLEEP1, 2 mode, no load, CR oscillation	—	43	90	μA
		SLEEP1, 2 mode, no load, ceramic oscillation	—	28	75	
Current consumption 3*	I _{DD3}	SUB mode, no load, C _G = 10 pF Capacitor for tripler 0.47 μF	—	10	45	μA
Current consumption 4*	I _{DD4}	STOP mode, no load, C _G = 10 pF Capacitor for tripler 0.47 μF	—	9	40	μA
High level input voltage	V _{IH}		0.8 × V _{DD}	—	—	V
Low level input voltage	V _{IL}		—	—	0.2 × V _{DD}	V
High level input leakage current	I _{LH}	V _{IN} = V _{DD}	—	—	1	μA
Low level input leakage current	I _{LL}	V _{IN} = V _{SS}	-1	—	—	μA
High level input current	I _{IH}	Pull-down resistor connected V _{IN} = V _{DD}	3	10	30	μA
Low level input current	I _{IL}	Pull-up resistor connected V _{IN} = V _{SS}	-30	-10	-3	μA
High level output current	I _{OH}	Output port V _{OUT} = 1.2 V	—	0.25	-0.1	mA
Low level output current	I _{OL}	Output port V _{OUT} = 0.4 V	0.5	1.3	—	mA
16-level detection input voltage	V _{AIN}	V _{REF} = V _{LC1}	0	—	V _{LC1}	V
		V _{REF} = V _{DD}	0	—	V _{DD}	
16-level detection high level input current	I _{AINH}	V _{AIN} = 0 V	-30	-6	—	μA
16-level detection low level input current	I _{AINL}	V _{AIN} = V _{LC1} when V _{REF} = V _{LC1} V _{AIN} = 1.0 V when V _{REF} = V _{DD}	—	7	30	μA
16-level detection reference voltage	V _{REF}	V _{REF} = V _{LC1}	0.940	1.0	1.060	V
16-level detection voltage error	V _{DET}	V _{DD} = 1.0 V when V _{REF} = V _{DD}	-1/2	—	1/2	LSB

* Not including the current consumption of the 16-level detection circuit.

CMOS 4-bit 1-chip MICROCOMPUTER
S-14L05AQS

Table 4

($V_{DD} = 1.5\text{ V}$, $f_{CL} = 400\text{ kHz}$, $f_X = 32.768\text{ kHz}$, $T_a = -10^\circ\text{C to } +70^\circ\text{C}$)

Item	Symbol	Conditions	Min.	Typ.	Max.	Unit
LCD driver voltage	V_{LC1}	$R_L = 1\text{ M}\Omega$ (V_{LC3} to V_{SS})	0.940	1.000	1.060	V
	V_{LC2}	Capacitor for tripler $0.47\ \mu\text{F}$	1.816	1.952	2.078	V
	V_{LC3}	$T_a = -10^\circ\text{C to } 50^\circ\text{C}$	2.707	2.910	3.091	V
High level output current2	I_{OH2}	COM_0 to COM_3 , SEG_0 to SEG_{47} $V_{OUT} = 2.95\text{ V}$, $V_{LC3} = 3.00\text{ V}$	—	-10.0	-3.0	μA
High level output current3	I_{OH3}	COM_0 to COM_3 , SEG_0 to SEG_{47} $V_{OUT} = 1.95\text{ V}$, $V_{LC2} = 2.00\text{ V}$	—	-10.0	-3.0	μA
Low level output current2	I_{OL2}	COM_0 to COM_3 , SEG_0 to SEG_{47} $V_{OUT} = 0.05\text{ V}$	3.0	12.0	—	μA
Schmitt hys teresis voltage	V_{WD}	Schmitt trigger input pin	—	0.4	—	V