

Contents

Features	1
Applications	1
Dimensions (24-pin SOP)	2
Pin Assignment	2
Terminal Functions	2
Block Diagram	3
Absolute Maximum Ratings	3
Recommended Operating Conditions	3
DC Electrical Characteristics	4
Instructions	6
Application Example (S-1463AF)	6

The S-1463AF/14L63AF is a CMOS 4-bit microcomputer, which integrates ROM, RAM, a timer and I/O ports on a single chip. Since the S-1463AF/14L63AF has a 2K×16-bit ROM, a special terminal for remote control signal output and key-on wake-up functions, it is ideal for infrared remote controller.

The S-14L63AF with a low operating voltage range (1.2 V to 3.6 V) is suitable for single-battery powered devices.

■ Features

Characteristics

- Power supply voltage : 2.2 to 6.0 V (S-1463AF)
1.2 to 3.6 V (S-14L63AF)
- Current consumption
 - S-1463AF : Running : 0.7 mA max. at 1 MHz, 3V operation
Standby : 0.1 μ A typ., 2.0 μ A max.
 - S-14L63AF : Running : 0.3 mA max. at 1 MHz, 1.5 V operation
Standby : 10 μ A max
- Operating frequency : 1 MHz
- Instruction execution time : 4.0 μ s at 1 MHz oscillation

Hardware functions

- ROM : 2K×16 bits
- RAM : 128×4 bits
- Port : 6-bit input, 7-bit output, 3-bit I/O
- Remote control signal output
- Standby counter
- Timer / Counter : 10-bit counter , 8-bit timer
- Watchdog timer
- Key-on wake-up
- Interrupt function: Internal (two)
- Oscillation circuit : Ceramic oscillator is built in
- Standby status : Stops oscillation, holds internal status

Software

- Instruction: 35 basic instruction sets (166 if addressing modes are included)
- 16-level subroutine nesting

Package

- 24-pin SOP

OTP version

- S-1463AF : For software evaluation, use the S-14P63AF
- S-14L63AF : For software evaluation, use the S-14P63AF

■ Applications

- Remote controller
- Other small-sized control equipment

CMOS 4-bit 1-chip MICROCOMPUTER
S-1463AF/14L63AF

■ **Dimensions (24-pin SOP)**

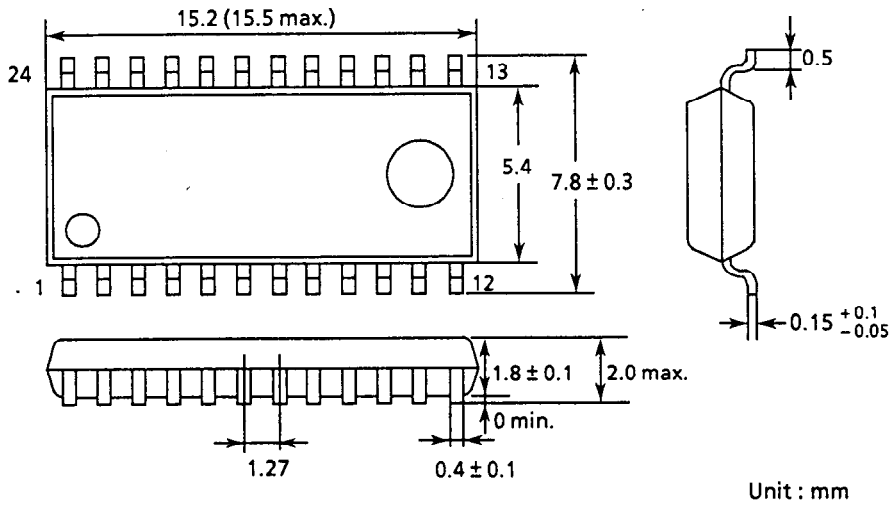

■ **Pin Assignment**

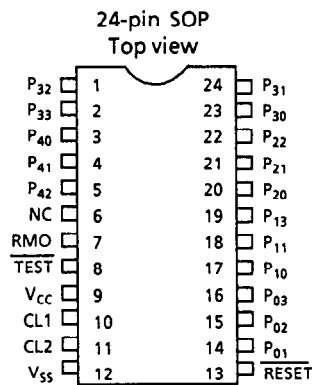

■ **Terminal Functions**

Name	I/O	Functions
V _{CC}	—	Positive power supply
V _{SS}	—	GND potential terminal
CL1	Input	Oscillation circuit input terminal
CL2	Output	Oscillation circuit output terminal
RESET	Input	Reset input terminal (pull-up resistor is built in)
TEST	Input	Test input terminal (pull-up resistor is built in)
RMO	Output	Remote control signal output terminal
P ₀₁ to P ₀₃	I/O	I/O ports, selectable in bit unit. Built-in pull-up resistor and Nch opendrain output are available in mask option.
P ₁₀ , P ₁₁ , P ₁₃ P ₂₀ to P ₂₂	Input	Input ports, also used as sense input of key matrix. Standby status is released by inputting low level in standby status. Pull-up resistor is built in.
P ₃₀ to P ₃₃ P ₄₀ to P ₄₂	Output	Output ports, also used as scan output of key matrix. Nch opendrain output is also available in mask option.

■ **Block Diagram**

The S-1463AF/14L63AF blocks connect with a 4-bit data bus (DB), 4-bit address bus (AB), 4-bit RAM address bus (RA) and 12-bit operation bus (OB).

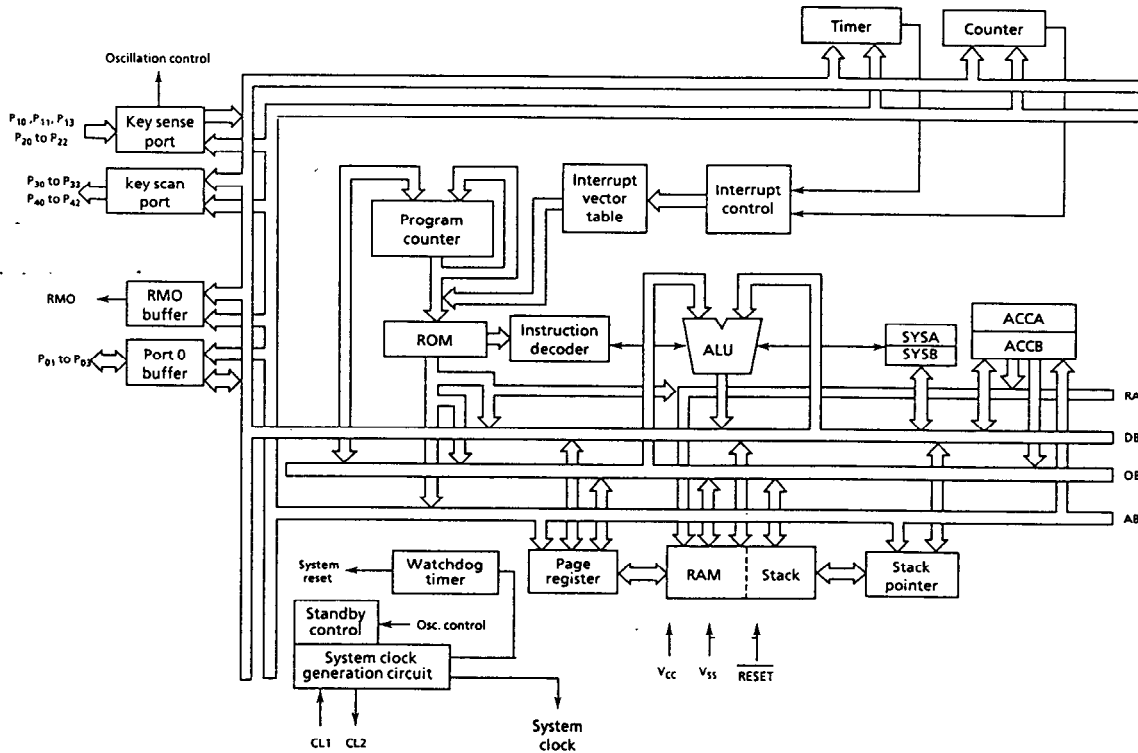

■ **Absolute Maximum Ratings**

Parameter	Symbol	Conditions	Ratings	Unit
Storage temperature	T _{stg}		-40 to +125	°C
Operating temperature	T _{opr}		-10 to +70	°C
Power supply voltage	V _{CC}	T _a = 25°C S-1463AF	-0.3 to +7.0	V
Power supply voltage	V _{CC}	T _a = 25°C S-14L63AF	-0.3 to +4.0	V
Input voltage	V _{IN}	T _a = 25°C	V _{SS} -0.3 to V _{CC} +0.3	V
Output voltage	V _{OUT}	T _a = 25°C	V _{SS} to V _{CC}	V
Power dissipation	P _D	T _a = 25°C	300	mW

■ **Recommended Operating Conditions**

(T_a = -10°C to +70°C)

Parameter	Symbol	Conditions	Min.	Typ.	Max.	Unit
Power supply voltage	V _{CC}	f _{OSC} = 1 MHz S-1463AF	2.2	—	6.0	V
Power supply voltage	V _{CC}	f _{OSC} = 1 MHz S-14L63AF	1.2	—	3.6	V
Input voltage	V _{IN}		0	—	V _{CC}	V
System clock frequency	f _{OSC}	V _{CC} = 2.2 to 6.0 V (S-1463AF) V _{CC} = 1.2 to 3.6 V (S-14L63AF)	0.2	—	1.0	MHz

CMOS 4-bit 1-chip MICROCOMPUTER

S-1463AF/14L63AF

■ DC Electrical Characteristics

1. S-1463AF

• $V_{CC} = 3\text{ V}$

($T_a = -10^\circ\text{C}$ to $+70^\circ\text{C}$)

Parameter	Symbol	Conditions(applicable terminals)	Min.	Typ.	Max.	Unit
Operating current consumption	I_{CCO}	$f_{OSC} = 1\text{ MHz}$, no load	—	0.25	0.7	mA
Standby current consumption	I_{CCS}	OFF mode	—	0.1	2.0	μA
High level input voltage	V_{IH}		$0.8 \times V_{CC}$	—	—	V
Low level input voltage	V_{IL}		—	—	$0.2 \times V_{CC}$	V
High level input leakage current	I_{LH}	All input pins* $V_{IN} = V_{CC}$	—	—	1	μA
Low level input leakage current	I_{LL}	Without pull-up resistor P_{01} to P_{03} , $V_{IN} = V_{SS}$	-1	—	—	μA
High level input current	I_{IH}	$\overline{\text{RESET}}$, $V_{IN} = V_{CC} - 0.3\text{V}$	-9	—	-0.9	μA
Low level input current 1	I_{IL1}	With pull-up resistor, P_{01} to P_{03} , $P_{10}, P_{11}, P_{13}, P_{20}$ to P_{22} , $V_{IN} = V_{SS}$	-90	-30	-10	μA
Low level input current 2	I_{IL2}	$\overline{\text{RESET}}$, $V_{IN} = V_{SS}$	-6	-2	-0.6	μA
Low level input current 3	I_{IL3}	$\overline{\text{TEST}}$, $V_{IN} = V_{SS}$	-30	-10	-3	μA
High level output current 1	I_{OH1}	RMO, $V_{OUT} = 2.1\text{ V}$	—	—	-5.0	mA
High level output current 2	I_{OH2}	P_{01} to P_{03}, P_{30} to P_{33}, P_{40} to P_{42} , $V_{OUT} = 2.6\text{ V}$	—	—	-100	μA
Low level output current 1	I_{OL1}	RMO, $V_{OUT} = 0.4\text{ V}$	250	—	—	μA
Low level output current 2	I_{OL2}	P_{01} to P_{03}, P_{30} to P_{33}, P_{40} to P_{42} , $V_{OUT} = 0.4\text{ V}$	1.0	—	—	mA
Schmitt hysteresis width	V_{WD}		—	1.0	—	V

* $\overline{\text{TEST}}, \overline{\text{RESET}}, P_{01}$ to $P_{03}, P_{10}, P_{11}, P_{13}, P_{20}$ to P_{22}

2. S-1463AF

• $V_{CC} = 5\text{ V}$

($T_a = -10^\circ\text{C}$ to $+70^\circ\text{C}$)

Parameter	Symbol	Conditions(applicable terminals)	Min.	Typ.	Max.	Unit
Operating current consumption	I_{CCO}	$f_{OSC} = 1\text{ MHz}$, no load	—	0.6	1.2	mA
Standby current consumption	I_{CCS}	OFF mode	—	0.1	5.0	μA
High level input voltage	V_{IH}		$0.8 \times V_{CC}$	—	—	V
Low level input voltage	V_{IL}		—	—	$0.2 \times V_{CC}$	V
High level input leakage current	I_{LH}	All input pins* $V_{IN} = V_{CC}$	—	—	1	μA
Low level input leakage current	I_{LL}	Without pull-up resistor P_{01} to P_{03} , $V_{IN} = V_{SS}$	-1	—	—	μA
High level input current	I_{IH}	$\overline{\text{RESET}}$, $V_{IN} = V_{CC} - 0.3\text{V}$	-15	—	-1.5	μA
Low level input current 1	I_{IL1}	With pull-up resistor, P_{01} to P_{03} , $P_{10}, P_{11}, P_{13}, P_{20}$ to P_{22} , $V_{IN} = V_{SS}$	-230	-90	-30	μA
Low level input current 2	I_{IL2}	$\overline{\text{RESET}}$, $V_{IN} = V_{SS}$	-15	-6	-2.4	μA
Low level input current 3	I_{IL3}	$\overline{\text{TEST}}$, $V_{IN} = V_{SS}$	-75	-30	-12	μA
High level output current 1	I_{OH1}	RMO, $V_{OUT} = 4.1\text{ V}$	—	—	-7	mA
High level output current 2	I_{OH2}	P_{01} to P_{03}, P_{30} to P_{33}, P_{40} to P_{42} , $V_{OUT} = 4.6\text{ V}$	—	—	-250	μA
Low level output current 1	I_{OL1}	RMO, $V_{OUT} = 0.4\text{ V}$	450	—	—	μA
Low level output current 2	I_{OL2}	P_{01} to P_{03}, P_{30} to P_{33}, P_{40} to P_{42} , $V_{OUT} = 0.4\text{ V}$	1.5	—	—	mA
Schmitt hysteresis width	V_{WD}		—	2.2	—	V

* $\overline{\text{TEST}}, \overline{\text{RESET}}, P_{01}$ to $P_{03}, P_{10}, P_{11}, P_{13}, P_{20}$ to P_{22}

3. S-14L63AF

• $V_{CC} = 1.5\text{ V}$

($T_a = -10^\circ\text{C}$ to $+70^\circ\text{C}$)

Parameter	Symbol	Conditions(applicable terminals)	Min.	Typ.	Max.	Unit
Operating current consumption	I_{CCO}	$f_{OSC} = 1\text{ MHz}$, no load	—	0.1	0.3	mA
Standby current consumption	I_{CCS}	OFF mode	—	1	10	μA
High level input voltage	V_{IH}		$0.8 \times V_{CC}$	—	—	V
Low level input voltage	V_{IL}		—	—	$0.2 \times V_{CC}$	V
High level input leakage current	I_{LH}	All input pins* $V_{IN} = V_{CC}$	—	—	1	μA
Low level input leakage current	I_{LL}	Without pull-up resistor P_{01} to P_{03} $V_{IN} = V_{SS}$	-1	—	—	μA
High level input current	I_{IH}	$\overline{\text{RESET}}$, $V_{IN} = V_{CC} - 0.3\text{ V}$	-4	—	-1	μA
Low level input current 1	I_{IL1}	With pull-up resistor, P_{01} to P_{03} , P_{10} , P_{11} , P_{13} , P_{20} to P_{22} , $V_{IN} = V_{SS}$	-30	-10	-3	μA
Low level input current 2	I_{IL2}	$\overline{\text{RESET}}$, $V_{IN} = V_{SS}$	-2	-0.6	-0.2	μA
Low level input current 3	I_{IL3}	$\overline{\text{TEST}}$, $V_{IN} = V_{SS}$	-8	-2	-0.5	μA
High level output current 1	I_{OH1}	RMO, $V_{OUT} = 1.1\text{ V}$	—	—	-2	mA
High level output current 2	I_{OH2}	P_{01} to P_{03} , P_{30} to P_{33} , P_{40} to P_{42} , $V_{OUT} = 1.1\text{ V}$	—	—	-100	μA
Low level output current 1	I_{OL1}	RMO, $V_{OUT} = 0.4\text{ V}$	200	—	—	μA
Low level output current 2	I_{OL2}	P_{01} to P_{03} , P_{30} to P_{33} , P_{40} to P_{42} , $V_{OUT} = 0.4\text{ V}$	0.5	—	—	mA
Schmitt hysteresis width	V_{WD}		—	0.4	—	V

* $\overline{\text{TEST}}$, $\overline{\text{RESET}}$, P_{01} to P_{03} , P_{10} , P_{11} , P_{13} , P_{20} to P_{22}

4. S-14L63AF

• $V_{CC} = 3.0\text{ V}$

($T_a = -10^\circ\text{C}$ to $+70^\circ\text{C}$)

Parameter	Symbol	Conditions(applicable terminals)	Min.	Typ.	Max.	Unit
Operating current consumption	I_{CCO}	$f_{OSC} = 1\text{ MHz}$, no load	—	0.5	1.0	mA
Standby current consumption	I_{CCS}	OFF mode	—	1	15	μA
High level input voltage	V_{IH}		$0.8 \times V_{CC}$	—	—	V
Low level input voltage	V_{IL}		—	—	$0.2 \times V_{CC}$	V
High level input leakage current	I_{LH}	All input pins* $V_{IN} = V_{CC}$	—	—	1	μA
Low level input leakage current	I_{LL}	Without pull-up resistor P_{01} to P_{03} $V_{IN} = V_{SS}$	-1	—	—	μA
High level input current	I_{IH}	$\overline{\text{RESET}}$, $V_{IN} = V_{CC} - 0.3\text{ V}$	-8	—	-2	μA
Low level input current 1	I_{IL1}	With pull-up resistor, P_{01} to P_{03} , P_{10} , P_{11} , P_{13} , P_{20} to P_{22} , $V_{IN} = V_{SS}$	-120	-50	-20	μA
Low level input current 2	I_{IL2}	$\overline{\text{RESET}}$, $V_{IN} = V_{SS}$	-10	-4	-1.5	μA
Low level input current 3	I_{IL3}	$\overline{\text{TEST}}$, $V_{IN} = V_{SS}$	-40	-16	-6	μA
High level output current 1	I_{OH1}	RMO, $V_{OUT} = 2.6\text{ V}$	—	—	-3	mA
High level output current 2	I_{OH2}	P_{01} to P_{03} , P_{30} to P_{33} , P_{40} to P_{42} , $V_{OUT} = 2.6\text{ V}$	—	—	-200	μA
Low level output current 1	I_{OL1}	RMO, $V_{OUT} = 0.4\text{ V}$	400	—	—	μA
Low level output current 2	I_{OL2}	P_{01} to P_{03} , P_{30} to P_{33} , P_{40} to P_{42} , $V_{OUT} = 0.4\text{ V}$	1.0	—	—	mA
Schmitt hysteresis width	V_{WD}		—	1.0	—	V

* $\overline{\text{TEST}}$, $\overline{\text{RESET}}$, P_{01} to P_{03} , P_{10} , P_{11} , P_{13} , P_{20} to P_{22}

CMOS 4-bit 1-chip MICROCOMPUTER S-1463AF/14L63AF

■ Instructions

1 . Instructions are 16-bit length, and executed in a single instruction cycle(4 clocks).

2 . The S-1463AF has 6 addressing modes.

- 1) Direct addressing mode
- 2) Relative addressing mode
- 3) Immediate addressing mode
- 4) Register addressing mode
- 5) Accumulator indirect addressing mode
- 6) Accumulator indexed addressing mode

3 . Number of instructions

	Basic	Including addressing modes
Transfer instruction	6	15
Arithmetic operation instruction	9	57
Logical operation instruction	8	66
Branch instruction	7	19
Rotate/shift instruction	2	6
CPU control instruction	3	3
Total	35	166

■ Application Example (S-1463AF)

