

**FOR AUTOMOTIVE 125°C OPERATION 2-WIRE
BUILT-IN QUARTZ CRYSTAL CONVENIENCE TIMER**www.ablicinc.com

© ABLIC Inc., 2017

Rev.1.1_01

The convenience timer is a CMOS timer IC which operates with low current consumption, and is suitable for the time management of the relative time.

The S-35710M compares the timer value and the value written to the internal register, and outputs an interrupt signal when the values match each other.

The timer is a 24-bit binary-up counter.

The internal register data can be set freely by users via a 2-wire serial interface. Consequently, the time before the occurrence of an interrupt signal can be set freely.

Since the S-35710M has a built-in quartz crystal, a matching assessment of the IC and the quartz crystal is unnecessary. Moreover, the number of external parts can also be reduced.

Caution This product can be used in vehicle equipment and in-vehicle equipment. Before using the product in the purpose, contact to ABLIC Inc. is indispensable.

■ Features

- Built-in 32.768 kHz quartz crystal
- Alarm interrupt function: Settable on the second time scale from 1 second to 194 days (Approximately half a year)
- Low current consumption: 0.25 μ A typ. ($V_{DD} = 3.0$ V, $T_a = +25^{\circ}$ C)
- Wide range of operation voltage: 1.8 V to 5.5 V
- 2-wire (I²C-bus) CPU interface
- Operation temperature range: $T_a = -40^{\circ}$ C to $+125^{\circ}$ C
- Lead-free (Sn 100%), halogen-free
- AEC-Q100/Q200 qualified*1

*1. Contact our sales office for details.

■ Application

- Time management of various systems during the sleep period

■ Package

- HSOP-8Q

■ **Block Diagram**

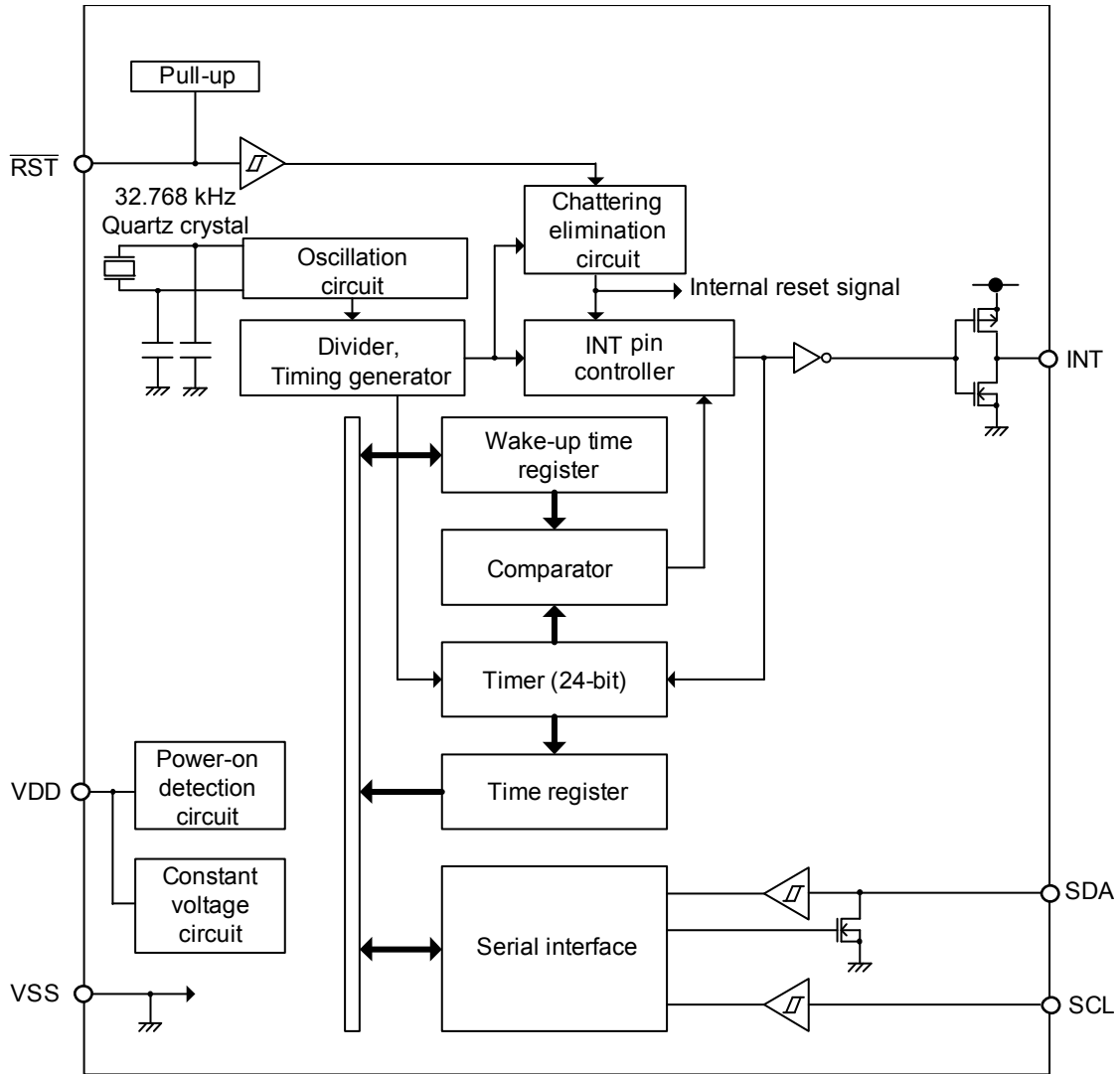

Figure 1

■ **AEC-Q100/Q200 Qualified**

This IC supports AEC-Q100/Q200 for operation temperature grade 1.
 Contact our sales office for details of AEC-Q100/Q200 reliability specification.

■ **Product Name Structure**

1. **Product name**

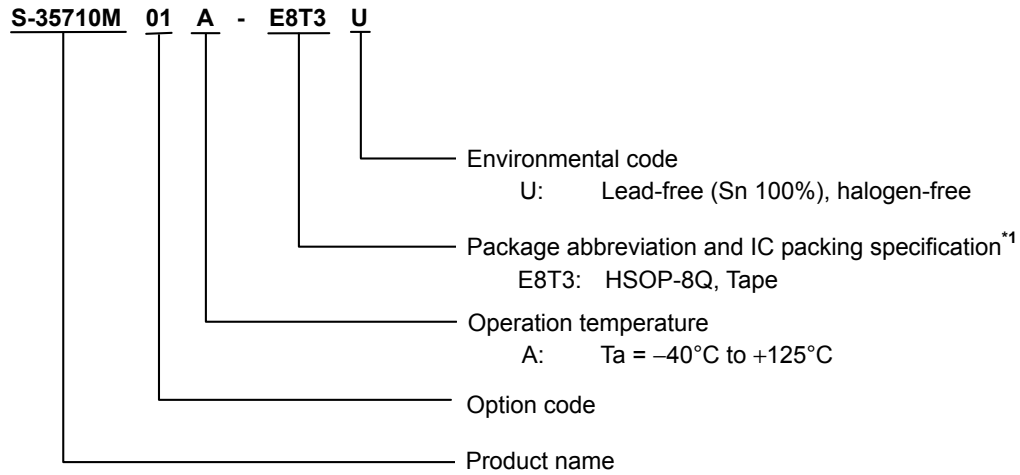

*1. Refer to the tape drawing.

2. **Package**

Table 1 Package Drawing Codes

Package Name	Dimension	Tape	Reel	Land
HSOP-8Q	FU008-A-P-SD	FU008-A-C-SD	FU008-A-R-SD	FU008-A-L-SD

■ Pin Configuration

1. HSOP-8Q

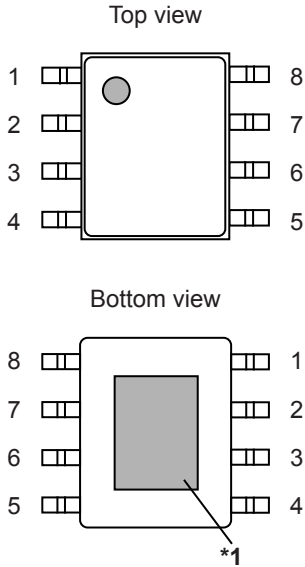

Table 2 List of Pins

Pin No.	Symbol	Description	I/O	Configuration
1	SCL	Input pin for serial clock	Input	CMOS input
2	VDD	Pin for positive power supply	–	–
3	$\overline{\text{RST}}$	Input pin for reset signal	Input	CMOS input (With pull-up resistor)
4	NC ^{*2}	No connection	–	–
5	NC ^{*2}	No connection	–	–
6	VSS	GND pin	–	–
7	INT	Output pin for interrupt signal	Output	CMOS output
8	SDA	I/O pin for serial data	Bi-directional	Nch open-drain output, CMOS input

Figure 2

- *1. Connect the heat sink of backside at shadowed area to the board, and set electric potential GND. However, do not use it as the function of electrode.
- *2. The NC pin is electrically open. Therefore, leave it open or connect it to the VDD pin or the VSS pin.

Caution Do not place a wiring on the backside of the package.

■ Pin Functions

1. SDA (I/O for serial data) pin

This is a data input / output pin for I²C-bus interface. The SDA pin inputs / outputs data by synchronizing with a clock pulse from the SCL pin. This pin has CMOS input and Nch open-drain output. Generally in use, the SDA pin is pulled up to V_{DD} potential via a resistor, and is used with wired-OR connection of other device of Nch open-drain output or open collector output.

2. SCL (Input for serial clock) pin

This is a clock input pin for I²C-bus interface. The SDA pin inputs / outputs data by synchronizing with this clock pulse.

3. $\overline{\text{RST}}$ (Input for reset signal) pin

This pin inputs the reset signal. The timer is reset when inputting "L" to the $\overline{\text{RST}}$ pin. The INT pin is set to "H" when inputting "H" to the $\overline{\text{RST}}$ pin, and the timer starts the operation. The $\overline{\text{RST}}$ pin has a built-in chattering elimination circuit. Regarding the chattering elimination circuit, refer to "■ RST Pin". Also, the $\overline{\text{RST}}$ pin has a pull-up resistor.

4. INT (Output for interrupt signal) pin

This pin outputs an interrupt signal. The interrupt signal is output when the time written to the wake-up time register comes. Regarding the operation of the interrupt signal output, refer to "■ INT Pin Interrupt Signal Output". Also, the INT pin output form is CMOS output.

5. VDD (Positive power supply) pin

Connect this pin with a positive power supply. Regarding the values of voltage to be applied, refer to "■ Recommended Operation Conditions".

6. VSS pin

Connect this pin to GND.

■ Equivalent Circuits of Pins

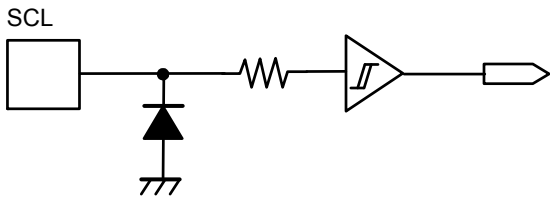

Figure 3 SCL Pin

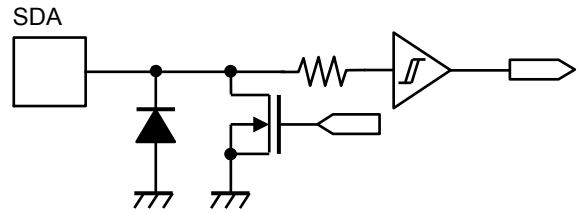

Figure 4 SDA Pin

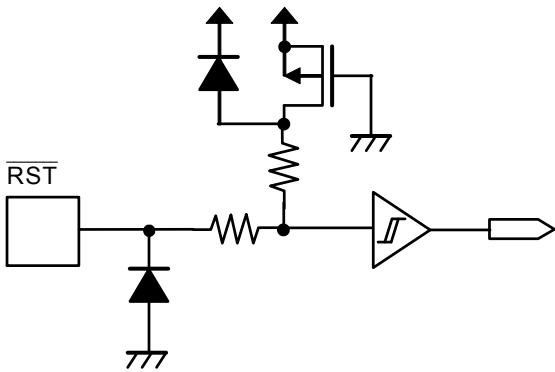

Figure 5 $\overline{\text{RST}}$ Pin

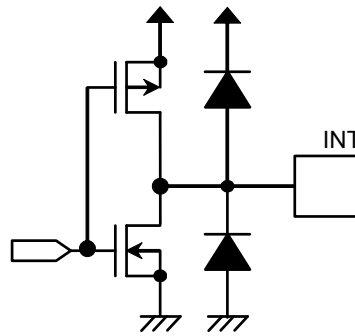

Figure 6 INT Pin

■ Absolute Maximum Ratings

Table 3

Item	Symbol	Applied Pin	Absolute Maximum Rating	Unit
Power supply voltage	V_{DD}	–	$V_{SS} - 0.3$ to $V_{SS} + 6.5$	V
Input voltage	V_{IN}	SDA, SCL	$V_{SS} - 0.3$ to $V_{SS} + 6.5$	V
		\overline{RST}	$V_{SS} - 0.3$ to $V_{DD} + 0.3 \leq V_{SS} + 6.5$	V
Output voltage	V_{OUT}	SDA	$V_{SS} - 0.3$ to $V_{SS} + 6.5$	V
		INT	$V_{SS} - 0.3$ to $V_{DD} + 0.3 \leq V_{SS} + 6.5$	V
Operation ambient temperature*1	T_{opr}	–	–40 to +125	°C
Storage temperature	T_{stg}	–	–55 to +125	°C

*1. Conditions with no condensation or frost. Condensation or frost causes short-circuiting between pins, resulting in a malfunction.

Caution The absolute maximum ratings are rated values exceeding which the product could suffer physical damage. These values must therefore not be exceeded under any conditions.

■ Recommended Operation Conditions

Table 4

($V_{SS} = 0$ V)

Item	Symbol	Condition	Min.	Typ.	Max.	Unit
Operation power supply voltage	V_{DD}	$T_a = -40^\circ\text{C}$ to $+125^\circ\text{C}$	1.8	–	5.5	V

■ Oscillation Characteristics

Table 5

($T_a = +25^\circ\text{C}$, $V_{DD} = 3.0$ V, $V_{SS} = 0$ V unless otherwise specified)

Item	Symbol	Condition	Min.	Typ.	Max.	Unit
Oscillation start voltage	V_{STA}	Within 10 seconds	1.8	–	5.5	V
Oscillation start time	t_{STA}	–	–	–	1	s
Frequency deviation	$\Delta f/f$	$T_a = -40^\circ\text{C}$ to $+125^\circ\text{C}$	–1	–	+1	%

■ DC Electrical Characteristics

Table 6

(Ta = -40°C to +125°C, V_{SS} = 0 V unless otherwise specified)

Item	Symbol	Applied Pin	Condition	Min.	Typ.	Max.	Unit
Current consumption 1	I _{DD1}	-	V _{DD} = 3.0 V, Ta = -40°C to +85°C, Out of communication, RST pin = V _{DD} , INT pin = no load	-	0.25	0.5	μA
			V _{DD} = 3.0 V, Ta = +125°C, Out of communication, RST pin = V _{DD} , INT pin = no load	-	0.75	1.2	μA
Current consumption 2	I _{DD2}	-	V _{DD} = 3.0 V, f _{SCL} = 1 MHz, During communication, RST pin = V _{DD} , INT pin = no load	-	170	300	μA
High level input leakage current	I _{IZH}	SDA, SCL, RST	V _{IN} = V _{DD}	-0.5	-	0.5	μA
Low level input leakage current	I _{IZL}	SDA, SCL	V _{IN} = V _{SS}	-0.5	-	0.5	μA
High level output leakage current	I _{OZH}	SDA	V _{OUT} = V _{DD}	-0.5	-	0.5	μA
Low level output leakage current	I _{OZL}	SDA	V _{OUT} = V _{SS}	-0.5	-	0.5	μA
High level input voltage	V _{IH}	SDA, SCL, RST	-	0.7 × V _{DD}	-	V _{SS} + 5.5	V
Low level input voltage	V _{IL}	SDA, SCL, RST	-	V _{SS} - 0.3	-	0.3 × V _{DD}	V
High level output voltage	V _{OH}	INT	I _{OH} = -0.4 mA	0.8 × V _{DD}	-	-	V
Low level output voltage	V _{OL}	SDA, INT	I _{OL} = 2.0 mA	-	-	0.4	V
Low level input current	I _{IL}	RST	V _{DD} = 3.0 V, V _{IN} = V _{SS}	-100	-30	-5	μA

■ AC Electrical Characteristics

Table 7 Measurement Conditions

Input pulse voltage	$V_{IH} = 0.8 \times V_{DD}$, $V_{IL} = 0.2 \times V_{DD}$
Input pulse rise / fall time	20 ns
Output reference voltage	$V_{OH} = 0.7 \times V_{DD}$, $V_{OL} = 0.3 \times V_{DD}$
Output load	100 pF

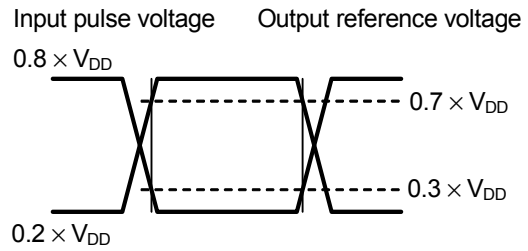

Figure 7 Input / Output Waveform during AC Measurement

Table 8 AC Electrical Characteristics

($T_a = -40^\circ\text{C}$ to $+125^\circ\text{C}$)

Item	Symbol	$V_{DD} = 1.8 \text{ V to } 2.5 \text{ V}$		$V_{DD} = 2.5 \text{ V to } 5.5 \text{ V}$		Unit
		Min.	Max.	Min.	Max.	
SCL clock frequency	f_{SCL}	0	400	0	1000	kHz
SCL clock "L" time	t_{LOW}	1.3	–	0.4	–	μs
SCL clock "H" time	t_{HIGH}	0.6	–	0.3	–	μs
SDA output delay time*1	t_{AA}	–	0.9	–	0.5	μs
Start condition set-up time	$t_{SU.STA}$	0.6	–	0.25	–	μs
Start condition hold time	$t_{HD.STA}$	0.6	–	0.25	–	μs
Data input set-up time	$t_{SU.DAT}$	100	–	80	–	ns
Data input hold time	$t_{HD.DAT}$	0	–	0	–	ns
Stop condition set-up time	$t_{SU.STO}$	0.6	–	0.25	–	μs
SCL, SDA rise time	t_R	–	0.3	–	0.3	μs
SCL, SDA fall time	t_F	–	0.3	–	0.3	μs
Bus release time	t_{BUF}	1.3	–	0.5	–	μs
Noise suppression time	t_i	–	50	–	50	ns

*1. Since the output form of the SDA pin is Nch open-drain output, the SDA output delay time is determined by the values of the load resistance and load capacitance outside the IC. **Figure 9** shows the relationship between the output load values.

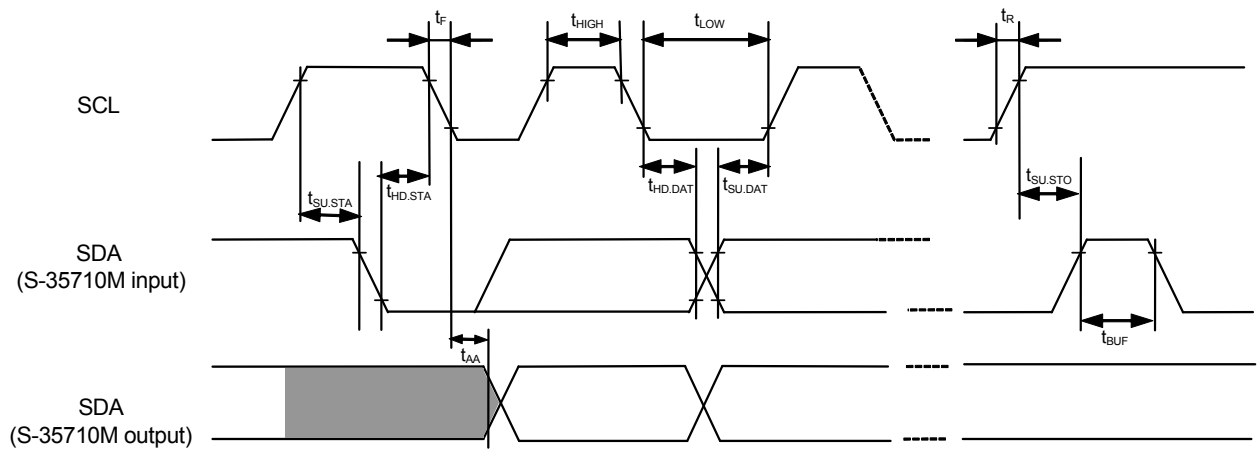

Figure 8 Bus Timing

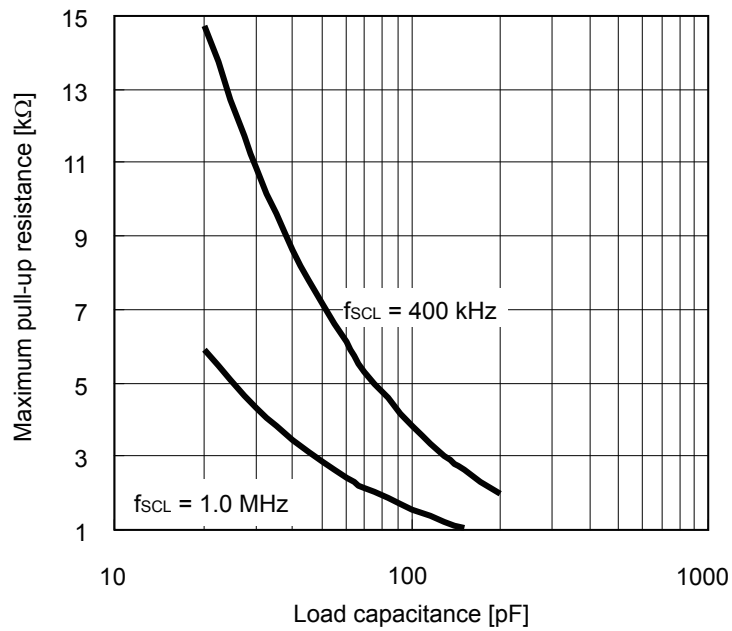

Figure 9 Output Load

■ INT Pin Interrupt Signal Output

After the $\overline{\text{RST}}$ pin changes from "L" to "H", the timer starts the operation. Then, the INT pin outputs "H" level when the timer value matches the value written to the wake-up time register. When the INT pin outputs "H" level, the timer stops and maintains the timer value.

The timer is reset by inputting "L" to the $\overline{\text{RST}}$ pin. After that, if "H" is input to the $\overline{\text{RST}}$ pin, the INT pin is set to "L" and the timer restarts the count-up action.

1. Write mode

If write operation is performed to the wake-up time register during the count-up action, the action will be restarted after resetting the timer. This operation is called "write mode". Before the timer value matches the value written to the wake-up time register, if "L" is input to the $\overline{\text{RST}}$ pin, the timer is reset.

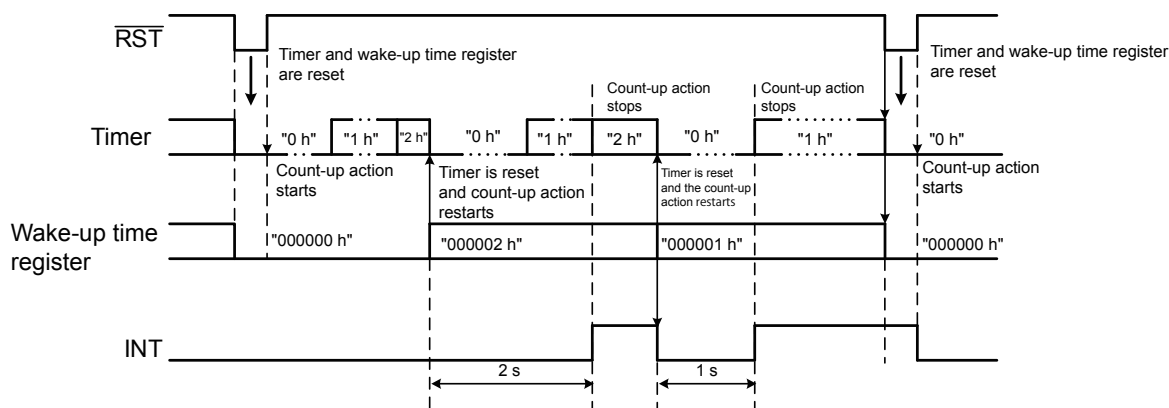

Figure 10 Output Timing of Handshake Time-out

2. Read mode

After the timer starts to operate, if write operation is not performed to the wake-up time register, the interrupt signal is not output from the INT pin. The timer stops at "FFFFFF h". The timer value during timing can be confirmed by reading the time register. This operation is called "read mode".

In order for the timer to operate again, set the $\overline{\text{RST}}$ pin from "L" to "H" or perform write operation to the wake-up time register. Regarding the detail when write operation is not performed to the wake-up time register, refer to **Figure 11**. Regarding the status transition for the S-35710M, refer to **Figure 12**.

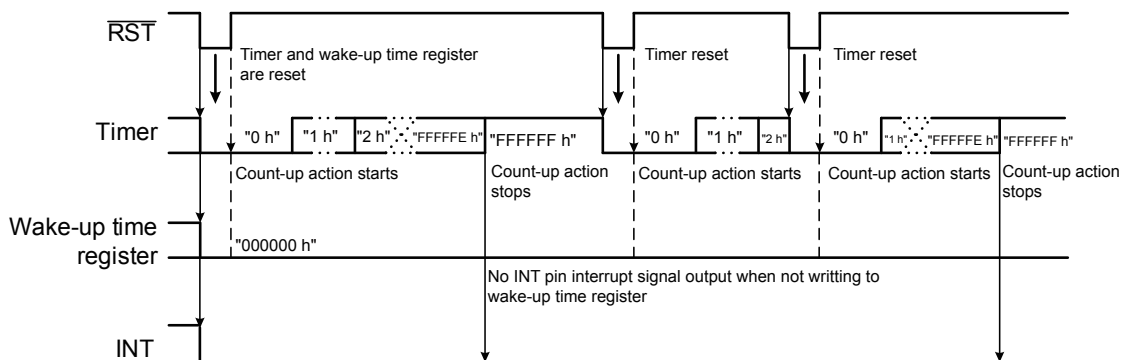

Figure 11 When Write Operation is not Performed to the Wake-up Time Register

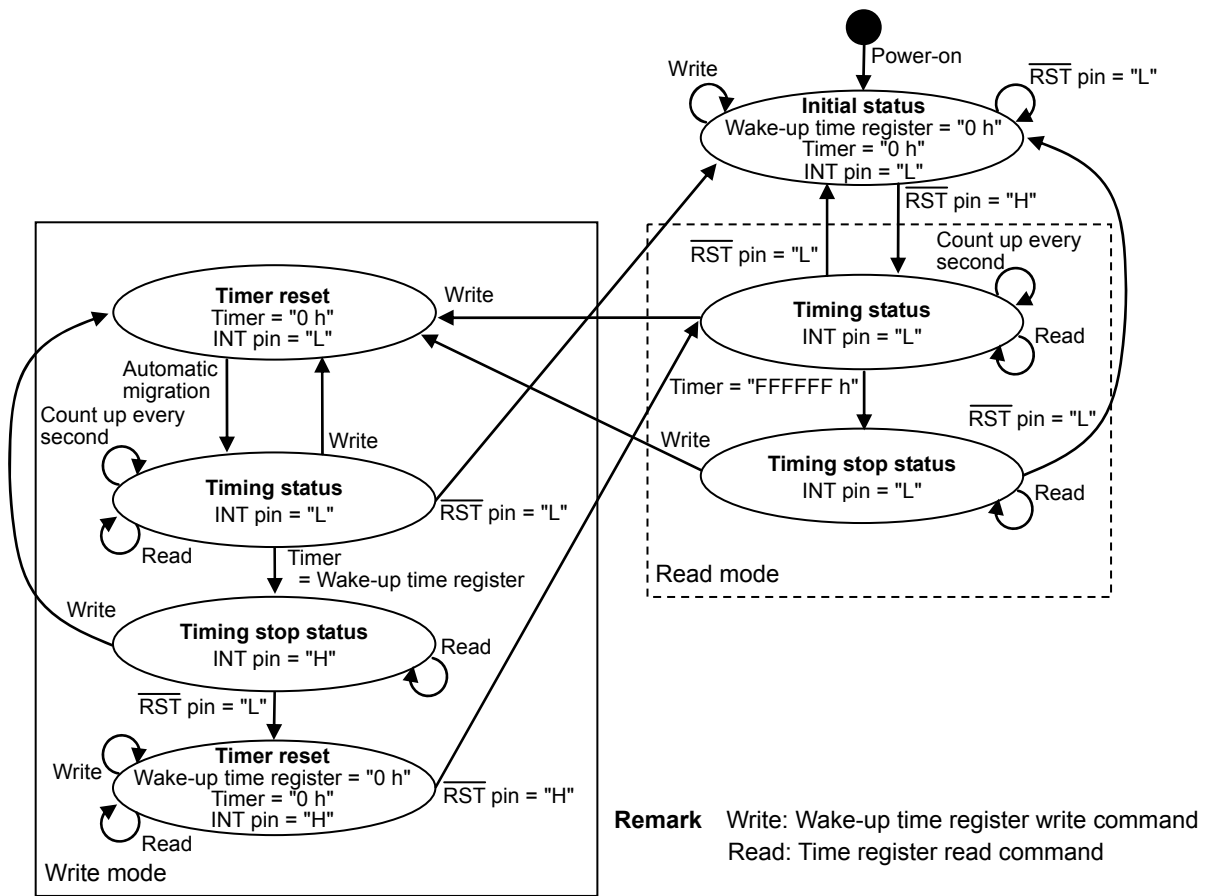

Figure 12 Status Transition Diagram for S-35710M

■ Configuration of Registers

1. Time register

The time register is a 3-byte register that stores the timer value in the binary code.
 The time register is read-only.

Perform the read operation of the time register in 3-byte unit from TM23 to TM0.

Example: 3 seconds (0000_0000_0000_0000_0000_0011)
 45 minutes (0000_0000_0000_1010_1000_1100)
 5 hours 30 minutes (0000_0000_0100_1101_0101_1000)

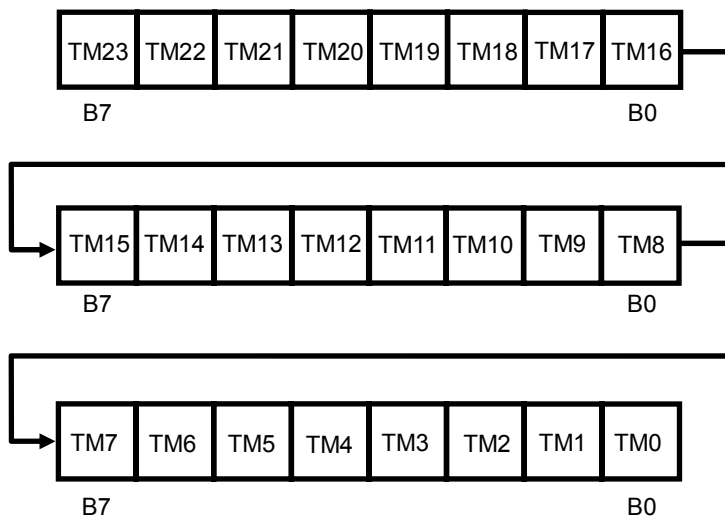

Figure 13

2. Wake-up time register

The wake-up time register is a 3-byte register that stores the wake-up time of the microcontroller in the binary code.
 The wake-up time register is possible for write and read.

Perform the write and read operation of the wake-up time register in 3-byte unit from WU23 to WU0.

When performing the read operation of the wake-up time register, set the \overline{RST} pin to "H". If the \overline{RST} pin is set to "L", the time register data is read.

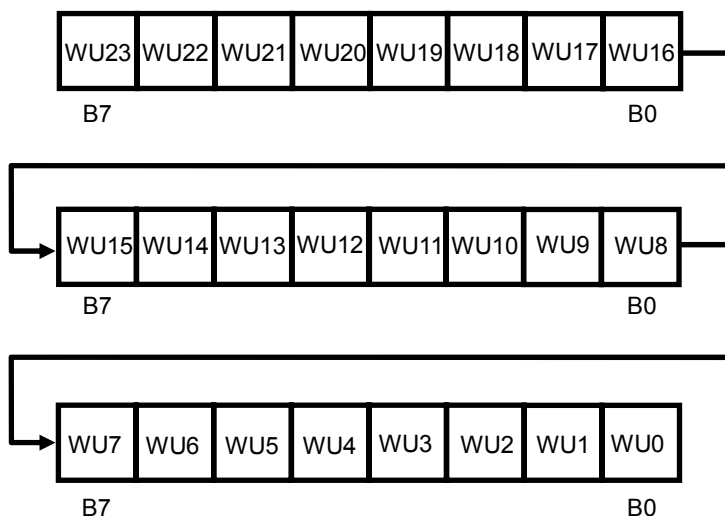

Figure 14

■ **Serial Interface**

The S-35710M transmits and receives various commands via I²C-bus serial interface to read / write data.

1. Start condition

When SDA changes from "H" to "L" with SCL at "H", the S-35710M recognizes start condition and the access operation is started.

2. Stop condition

When SDA changes from "L" to "H" with SCL at "H", the S-35710M recognizes stop condition and the access operation is completed. The S-35710M enters standby mode, consequently.

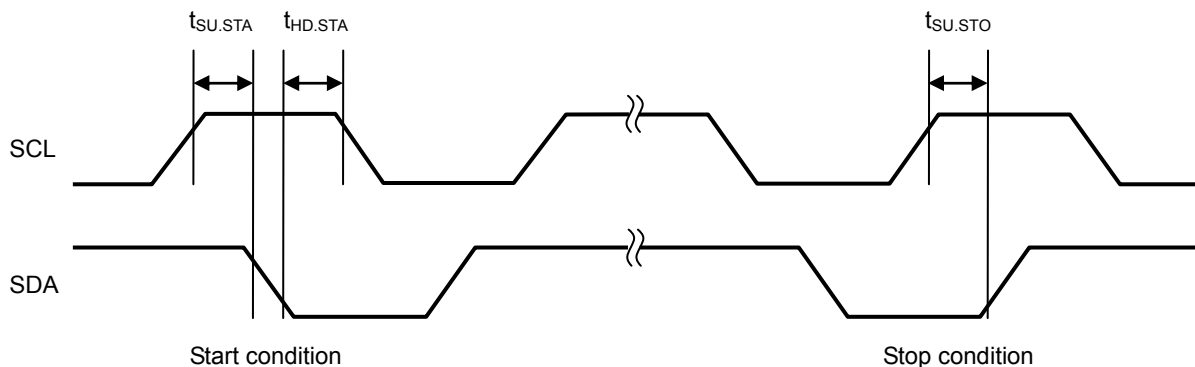

Figure 15 Start / Stop Condition

3. Data transmission and acknowledge

The data transmission is performed at every 1 byte after the start condition detection. Pay attention to the specification of $t_{SU.DAT}$ and $t_{HD.DAT}$ when changing SDA, and perform the operation when SCL is "L". If SDA changes when SCL is "H", the start / stop condition is recognized even during the data transmission, and the access operation will be interrupted.

Whenever a 1-byte data is received during data transmission, the receiving device returns an acknowledge. For example, as shown in **Figure 16**, assume that the S-35710M is a receiving device, and the master device is a transmitting device. If the clock pulse at the 8th bit falls, the master device releases SDA. Consequently, the S-35710M, as an acknowledge, sets SDA to "L" during the 9th bit pulse. The access operation is not performed properly when the S-35710M does not output an acknowledge.

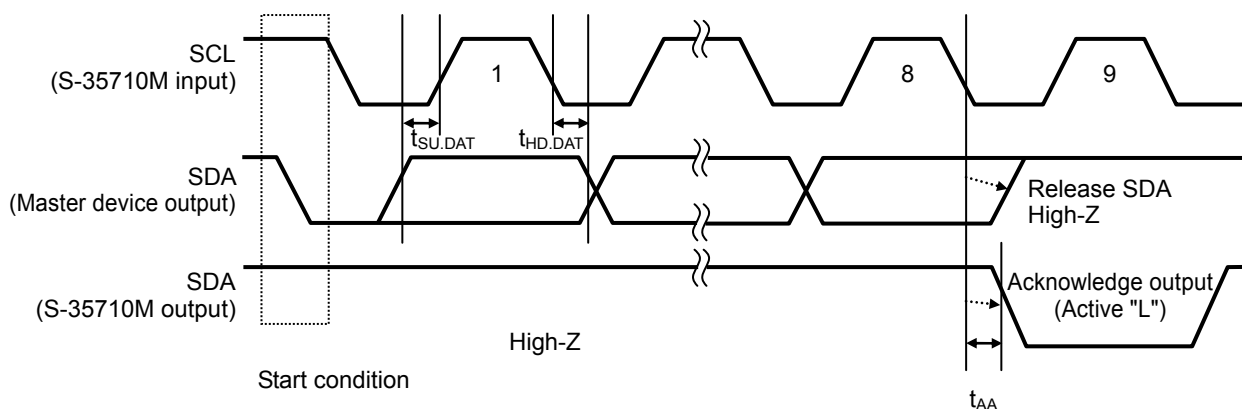

Figure 16 Acknowledge Output Timing

4. Data transmission format

After the start condition transmission, the 1st byte is a slave address and a command (read / write bit) that shows the transmission direction of the data at the 2nd byte or subsequent bytes.

The slave address of the S-35710M is specified to "0110010". The data can be written to the wake-up time register when read / write bit is "0", and the data of the wake-up time register or the time register can be read when read / write bit is "1".

When the data can be written to the wake-up time register, input the data from the master device in order of B7 to B0. The acknowledge ("L") is output from the S-35710M whenever a 1-byte data is input.

When the data of the wake-up time register or the time register can be read, the data from the S-35710M is output in order of B7 to B0 in byte unit. Input the acknowledge ("L") from the master device whenever a 1-byte data is input. However, do not input the acknowledge for the last data byte (NO_ACK). By this, the end of the data read is informed. After the master device receives / transmits the acknowledge for the last data byte, input the stop condition to the S-35710M to finish the access operation.

When the master device inputs start condition without inputting stop condition at this time, the S-35710M becomes restart condition, and can transmit / receive the data continuously if the master device inputs the slave address continuously.

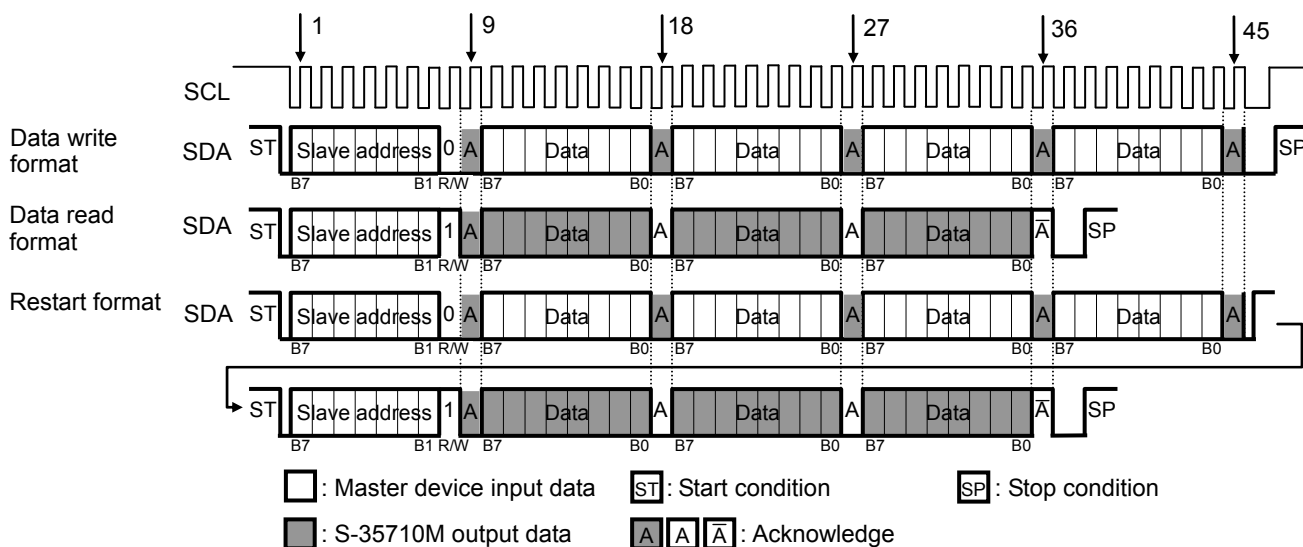

Figure 17 Data Transmission Format of Serial Interface

5. Read operation of time register

Transmit the start condition and slave address from the master device. The slave address of the S-35710M is specified to "0110010". Next, the data of the time register can be read when the read / write bit is "1".

The 2nd byte to the 4th byte are used as the time register. Each byte from B7 is transmitted.

When the read operation of the time register is finished, transmit "1" (NO_ACK) to the acknowledge after B0 is output from the master device, and then transmit the stop condition.

The time register is a 3-byte register. "1" is read if the read operation is performed continuously after reading 3 bytes of the time register. Regarding the time register, refer to "■ Configuration of Registers".

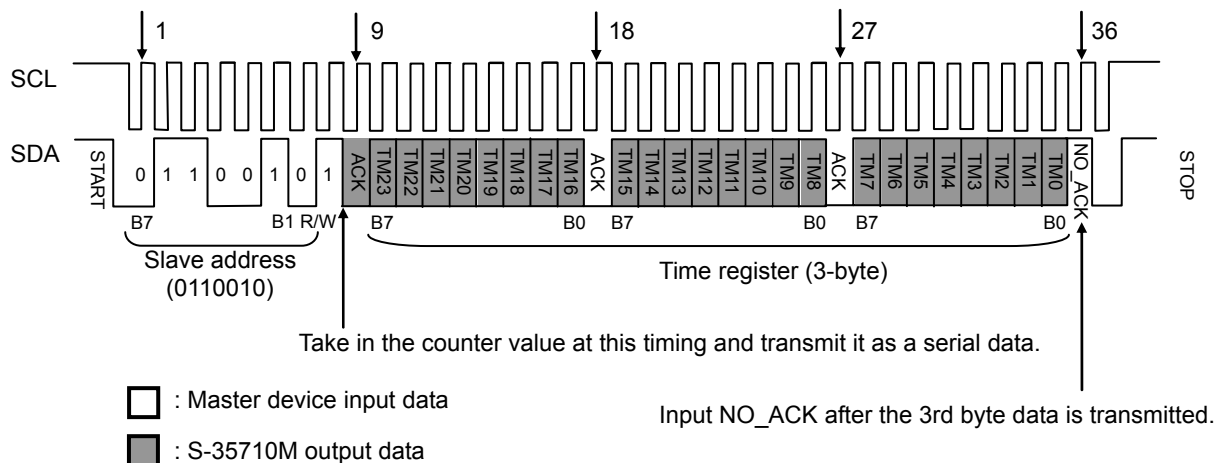

Figure 18 Read Timing of Time Register

6. Write operation of wake-up time register

Transmit the start condition and slave address from the master device. The slave address of the S-35710M is specified to "0110010". Next, transmit "0" to the read / write bit.

Transmit the 2nd byte data. Set B7 to "1" since it is an address pointer. Set B6 to B1 to "0" or "1" since they are dummy data. Make sure to set B0 to "1" since it is a test bit.

The 3rd byte to the 5th byte are used as the wake-up time register.

Transmit the stop condition from the master device to finish the access operation.

Regarding the wake-up time register, refer to "■ Configuration of Registers".

Write operation of the wake-up time register is performed each byte, so transmit the data in 3-byte unit. Note that the S-35710M may not operate as desired if the the data is not transmitted in 3-byte unit.

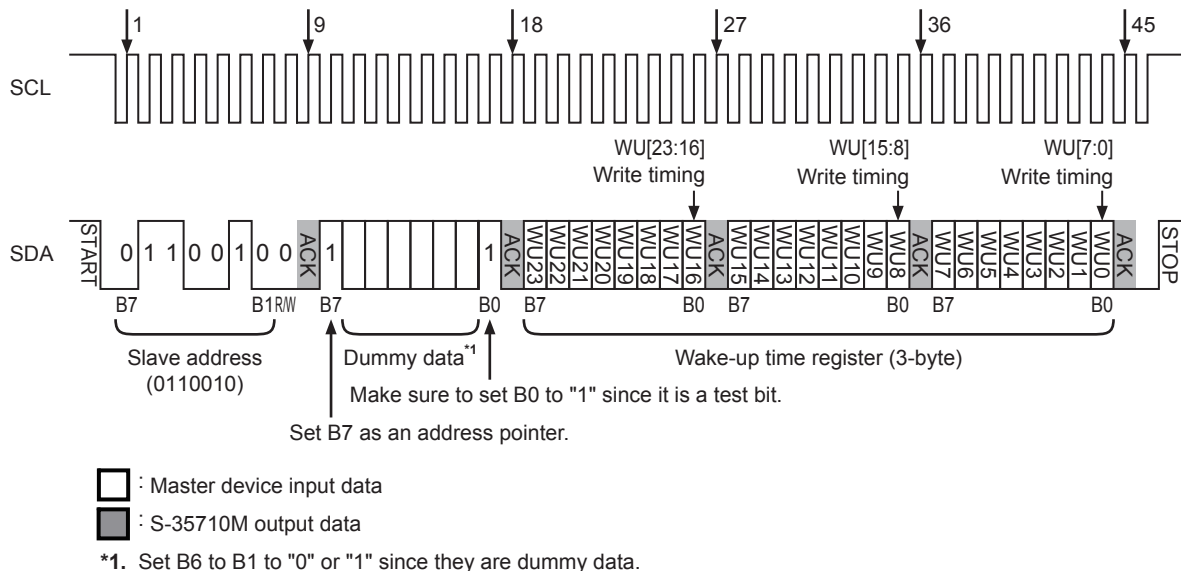

Figure 19 Write Timing of Wake-up Time Register
ABLIC Inc.

7. Read operation of wake-up time register

Perform the read operation of the wake-up time register with the restart format. Regarding the restart format, refer to "4. Data transmission format".

When performing the read operation of the wake-up time register, set the \overline{RST} pin to "H". If the \overline{RST} pin is set to "L", the time register data is read.

Transmit the start condition and the slave address from the master device. The slave address of the S-35710M is specified to "0110010". Next, transmit "0" to the read / write bit.

B7 in the 2nd byte is an address pointer. Set B7 to "0" when reading the wake-up time register. Next, transmit the dummy data to B6 to B1. Make sure to set B0 to "1" since it is a test bit. This processing is called "dummy write".

Then transmit the start condition, the slave address and the read / write bit. The data of the wake-up time register can be read when the read / write bit is set to "1".

Consequently, the data of the wake-up time register is output from the S-35710M. Each byte from B7 is transmitted. When the read operation of the wake-up time register is finished, transmit "1" (NO_ACK) to the acknowledge after B0 output from the master device, and then transmit the stop condition.

The wake-up time register is a 3-byte register. "1" is read if the read operation is performed continuously after reading 3 bytes of the wake-up time register.

Regarding the wake-up time register, refer to "■ Configuration of Registers".

Moreover, the internal address pointer is reset if recognizing the stop condition. Therefore, do not transmit the stop condition after dummy write operation. The time register is read if performing the read operation of the register after transmitting the stop condition.

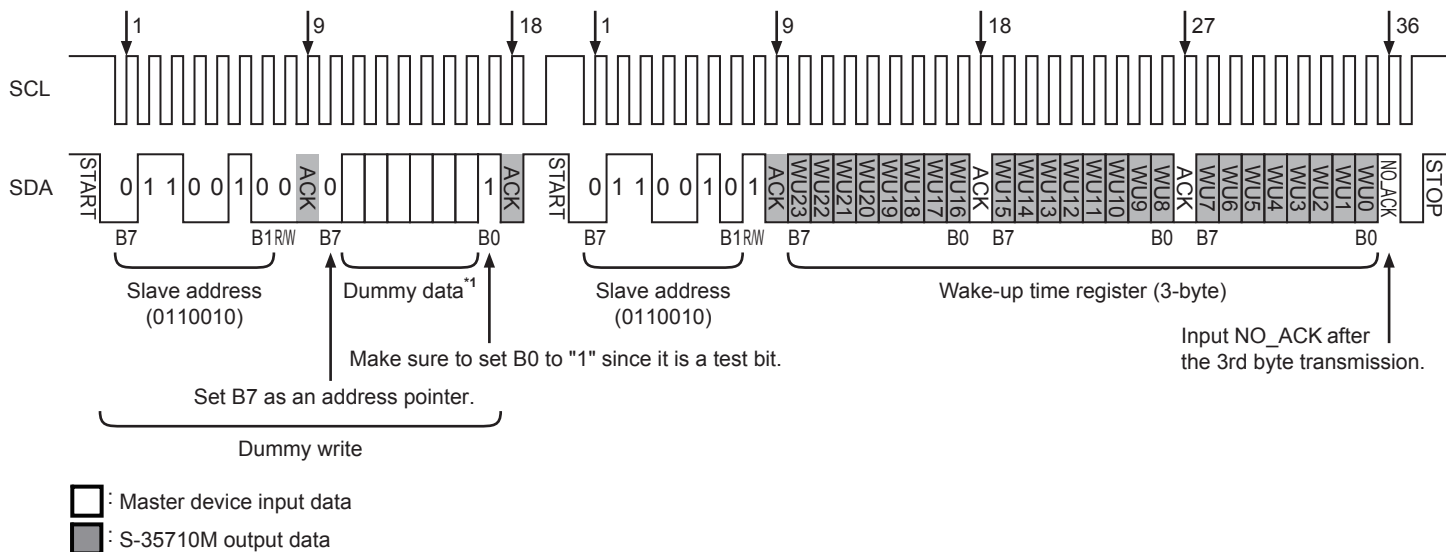

*1. Set B6 to B1 to "0" or "1" since they are dummy data.

Figure 20 Read Timing of Wake-up Time Register

■ **Release of SDA**

The $\overline{\text{RST}}$ pin of the S-35710M does not perform the reset operation of the communication interface. Therefore, the stop condition is input to reset the internal interface circuit usually.

However, the S-35710M does not accept the stop condition from the master device when in the status that SDA outputs "L" (at the time of acknowledge outputting or reading). Consequently, it is necessary to finish the acknowledge output or read operation. **Figure 21** shows the SDA release method.

First, input the start condition from the master device (since SDA of the S-35710M outputs "L", the S-35710M can not detect the start condition). Next, input the clocks for 1-byte data access (9 clocks) from SCL. During the time, release SDA of the master device. By this, the SDA input / output before communication interrupt is completed, and SDA of the S-35710M becomes release status. Continuously, if the stop condition is input, the internal circuit resets and the communication returns to normal status.

It is strongly recommended that the SDA release method is performed at the time of system initialization after the power supply voltage of the master device is raised.

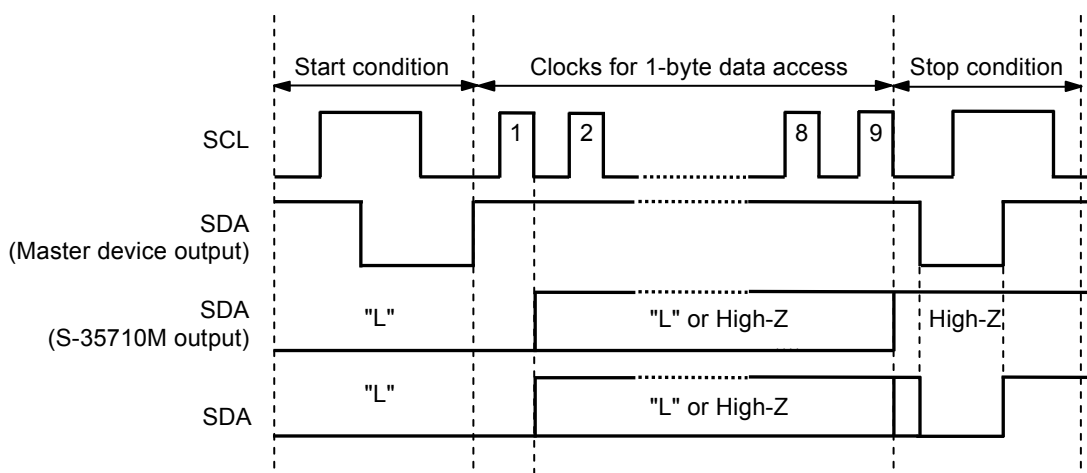
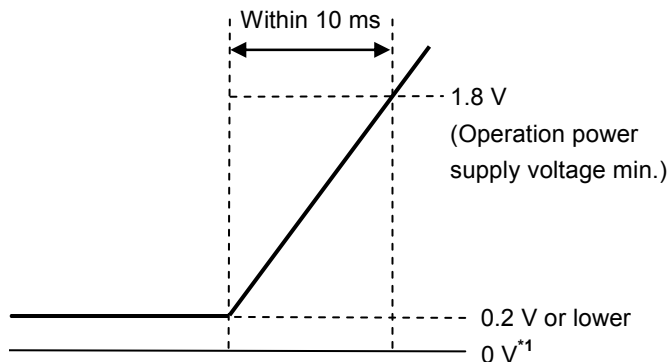

Figure 21 SDA Release Method

■ Power-on Detection Circuit

In order for the power-on detection circuit to operate normally, raise the power supply voltage of the IC from 0.2 V or lower to that it reaches 1.8 V of the operation power supply voltage minimum value within 10 ms, as shown in **Figure 22**.



*1. 0 V means that there is no potential difference between the VDD pin and the VSS pin of the S-35710M.

Figure 22 How to Raise Power Supply Voltage

If the power supply voltage of the S-35710M cannot be raised under the above conditions, the power-on detection circuit may not operate normally and an oscillation may not start. In such case, perform the operations shown in "1. When power supply voltage is raised at $\overline{\text{RST}}$ pin = "L" " and "2. When power supply voltage is raised at $\overline{\text{RST}}$ pin = "H" ".

1. When power supply voltage is raised at $\overline{\text{RST}}$ pin = "L"

Set the $\overline{\text{RST}}$ pin to "L" until the power supply voltage reaches 1.8 V or higher. While the $\overline{\text{RST}}$ pin is set to "L", the oscillation start signal becomes "H", and the crystal oscillation circuit normally oscillates. If the $\overline{\text{RST}}$ pin is set to "H" after the power supply voltage reaches 1.8 V, the oscillation start signal becomes "L" within 500 ms, and the oscillation status is maintained.

The current consumption increases while the $\overline{\text{RST}}$ pin is set to "L" (30 μA typ.).

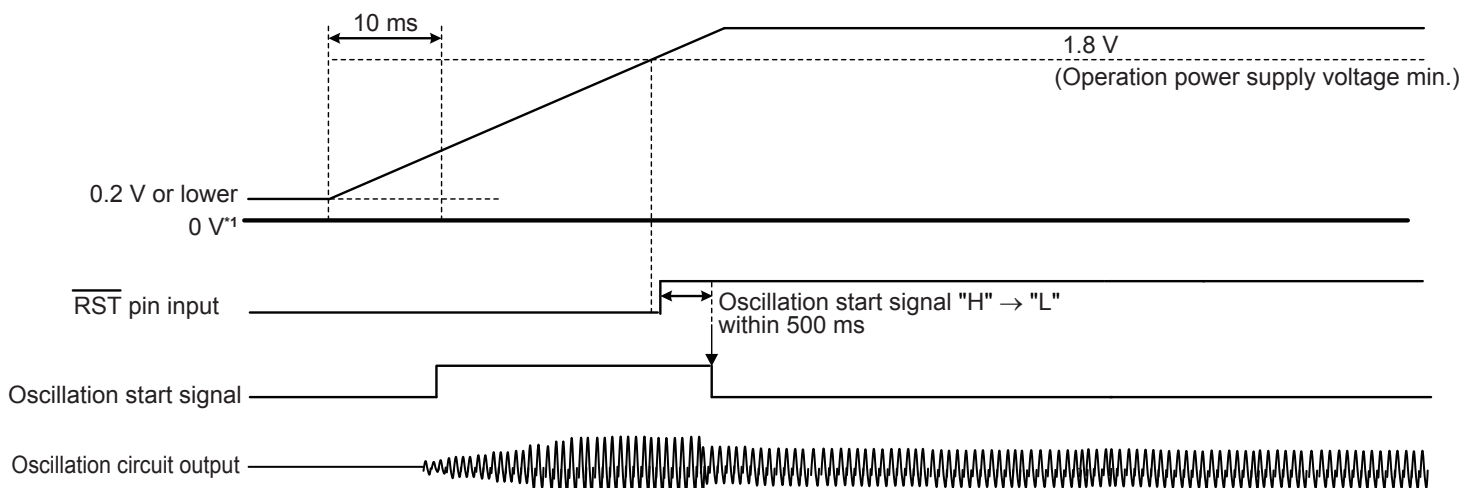

*1. 0 V means that there is no potential difference between the VDD pin and the VSS pin of the S-35710M.

Figure 23 When Power Supply Voltage is Raised at $\overline{\text{RST}}$ Pin = "L"

2. When power supply voltage is raised at $\overline{\text{RST}}$ pin = "H"

Set the $\overline{\text{RST}}$ pin to "L" after the power supply voltage reaches 1.8 V or higher. If the $\overline{\text{RST}}$ pin is set to "L" for 500 ms or longer, the oscillation start signal becomes "H", and the crystal oscillation circuit normally oscillates. After that, if the $\overline{\text{RST}}$ pin is set to "H", the oscillation start signal becomes "L" within 500 ms, and the oscillation status is maintained. The current consumption increases while the $\overline{\text{RST}}$ pin is set to "L" (30 μA typ.).

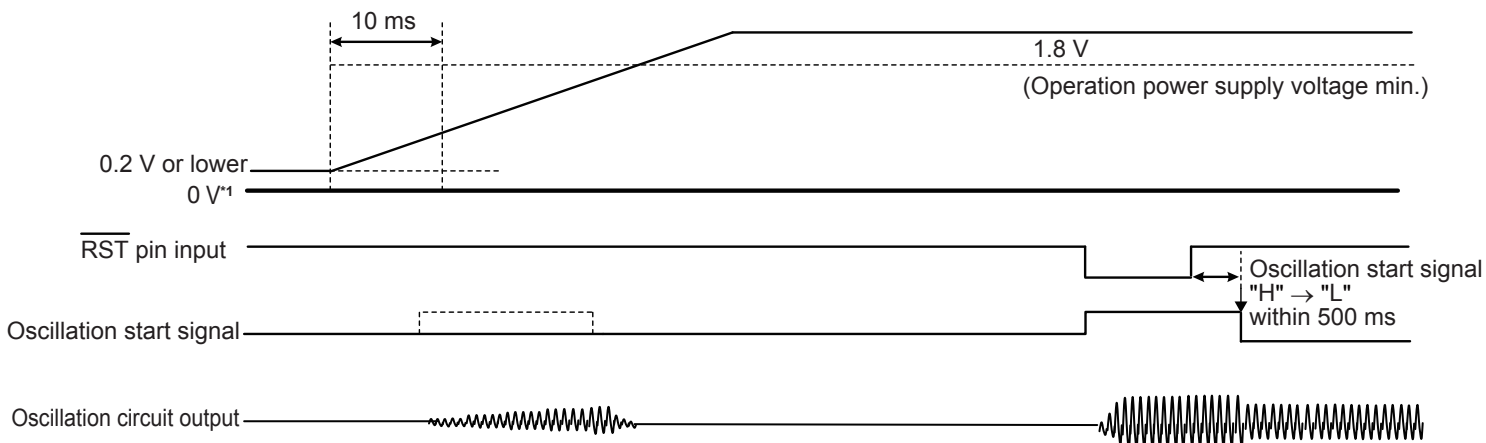

*1. 0 V means that there is no potential difference between the VDD pin and the VSS pin of the S-35710M.

Figure 24 When Power Supply Voltage is Raised at $\overline{\text{RST}}$ Pin = "H"

The $\overline{\text{RST}}$ pin has a built-in chattering elimination circuit. To determine the $\overline{\text{RST}}$ pin "H" input, perform communication subsequent to setting the interval of 3.5 periods (0.438 seconds) of clock (8 Hz) or longer after the $\overline{\text{RST}}$ pin changes from "L" to "H".

Regarding the chattering elimination of the $\overline{\text{RST}}$ pin, refer to "■ $\overline{\text{RST}}$ Pin".

■ **RST Pin**

1. **Chattering elimination**

The $\overline{\text{RST}}$ pin has a built-in chattering elimination circuit, and the output logic is active "L".

Figure 25 is a timing chart of chattering elimination. Perform sampling at 8 Hz and operate the shift register circuit. Perform the shift operation for 3 times, and reset the counter when DF1 to DF3 are all "L". During the chattering elimination, the pulse width, 2 periods (approximately 0.25 seconds) of clock (8 Hz), can be eliminated. To determine the $\overline{\text{RST}}$ pin "L" input, maintain the $\overline{\text{RST}}$ pin "L" input during the period longer than 3.5 periods (0.438 seconds) of clock (8 Hz). Similarly, to determine the $\overline{\text{RST}}$ pin "H" input, maintain the $\overline{\text{RST}}$ pin "H" input during the period longer than 3.5 periods (0.438 seconds) of clock (8 Hz).

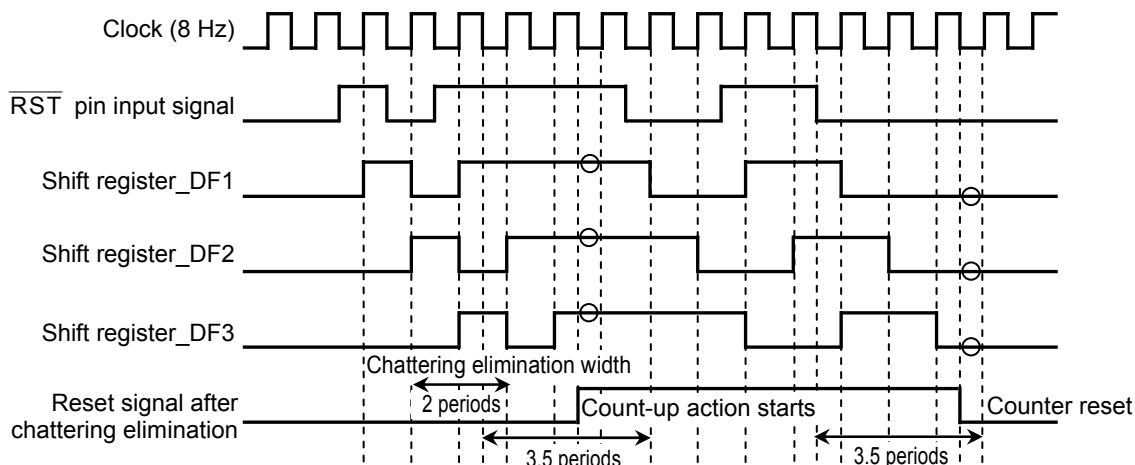

Figure 25 Timing Chart of Chattering Elimination

2. **Operation at power-on**

At power-on, the reset signal after chattering elimination is "L" regardless of the $\overline{\text{RST}}$ pin status. Consequently, the S-35710M becomes initial status (Refer to "**Figure 12 Status Transition Diagram for S-35710M**") and can not perform write operation to the wake-up time register. When the reset signal after chattering elimination is "L", the no acknowledge is output in the 2nd or subsequent bytes if write operation is performed to the wake-up time register.

If the crystal oscillation circuit starts to oscillate after power-on, the clock operates and the reset signal after chattering elimination becomes "H", the S-35710M then migrates to read mode. This makes the write operation to the wake-up time register possible. **Figure 26** shows the timing chart at power-on.

The write-disable time period of the wake-up time register showed in **Figure 26** changes according to the oscillation start time. If the no acknowledge is output from the S-35710M at the time of write operation to the wake-up time register immediately after power-on, it is recommended to set a time interval of approximately 0.5 seconds to 1 second for the next communication until the oscillation is stabilized.

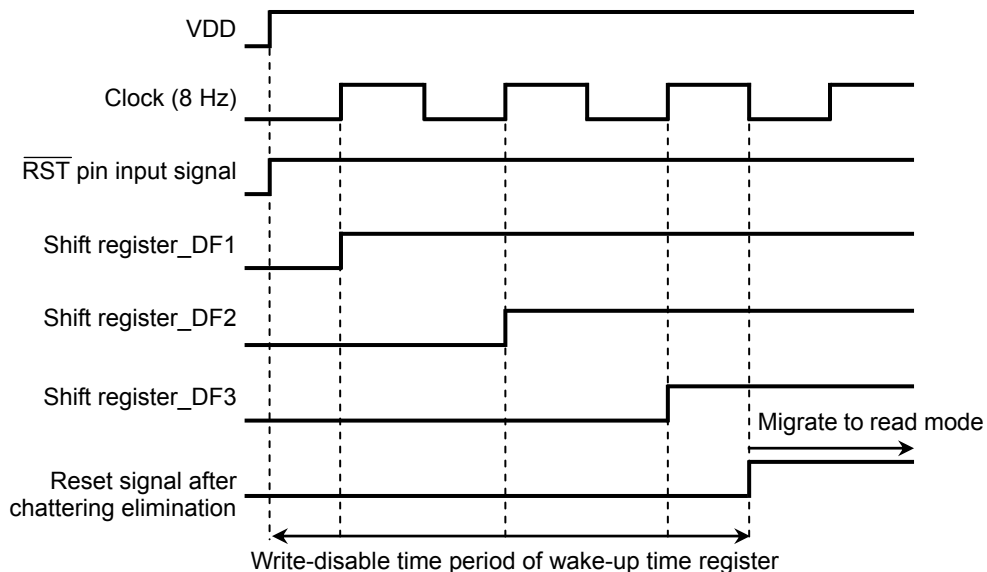

Figure 26 Timing Chart at Power-on

■ Example of Application Circuit

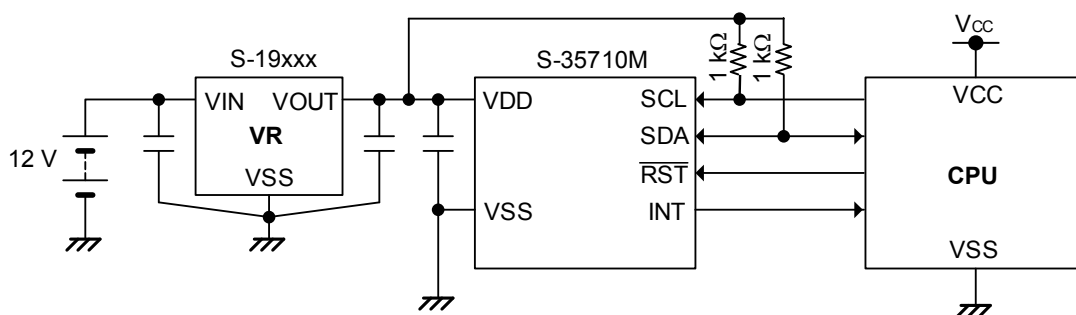

Figure 27

- Caution
1. Start communication under stable condition after turning on the system power supply.
 2. The above connection diagrams do not guarantee operation. Set the constants after performing sufficient evaluation using the actual application.

■ Precautions

- Do not apply excessive impact or vibration since this IC has a built-in quartz crystal. Also, do not locate a device which generates high level of electronic noise near this IC.
- Depending on the device, the usage condition and other reasons, the built-in quartz crystal may be damaged due to the impact or vibration at the time of board splitting and mounting. Perform thorough evaluation with the actual application.
- The built-in quartz crystal may be damaged due to the resonance when executing the ultrasonic cleaning. Therefore, the operation of the IC is not guaranteed if the ultrasonic cleaning is executed.
- Do not apply an electrostatic discharge to this IC that exceeds the performance ratings of the built-in electrostatic protection circuit.
- ABLIC Inc. claims no responsibility for any disputes arising out of or in connection with any infringement by products including this IC of patents owned by a third party.

■ **Characteristics (Typical Data)**

1. Current consumption 1 vs. Power supply voltage characteristics

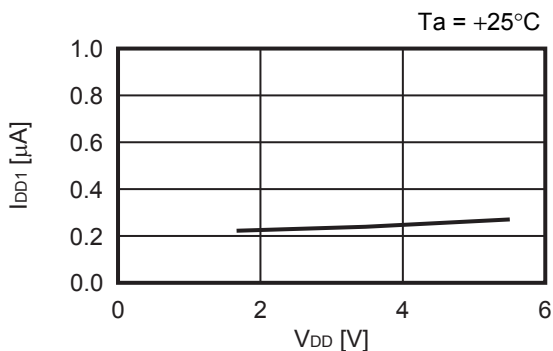

2. Current consumption 2 vs. SCL frequency characteristics

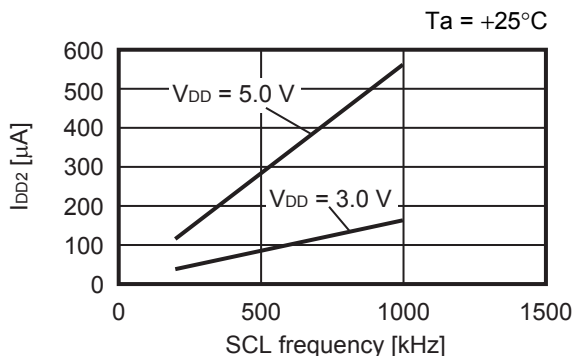

3. Current consumption 1 vs. Temperature characteristics

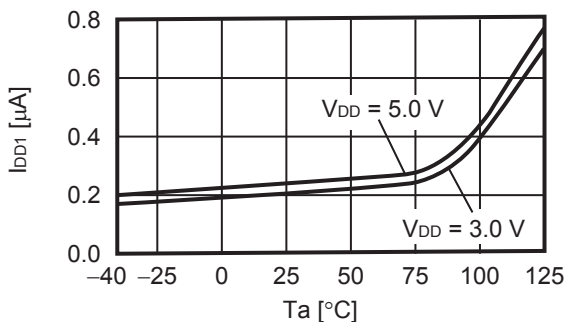

4. Oscillation frequency vs. Power supply voltage characteristics

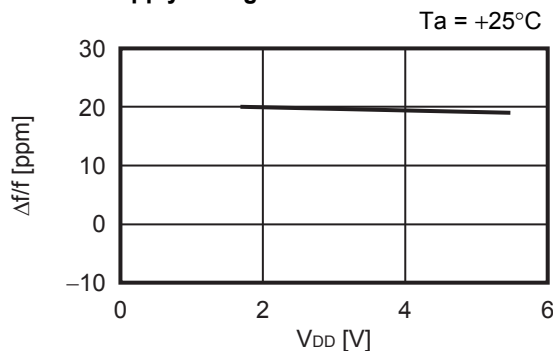

5. Oscillation frequency vs. Temperature characteristics

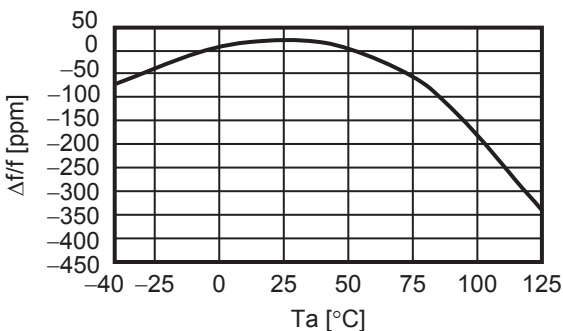

6. Low level output current vs. Output voltage characteristics

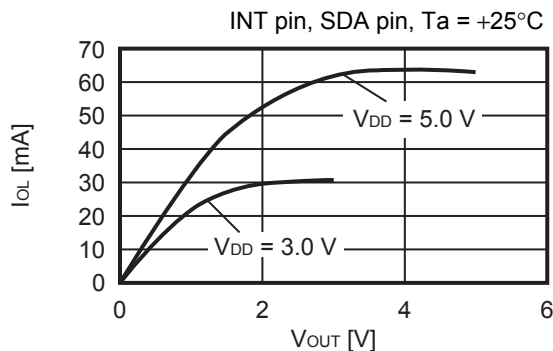

7. High level output current vs. V_DD - V_OUT characteristics

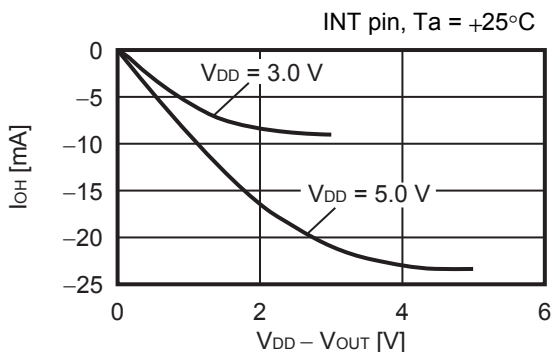

8. Low level input current vs. Power supply voltage characteristics

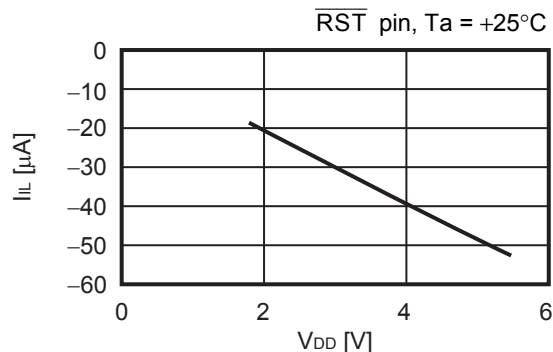

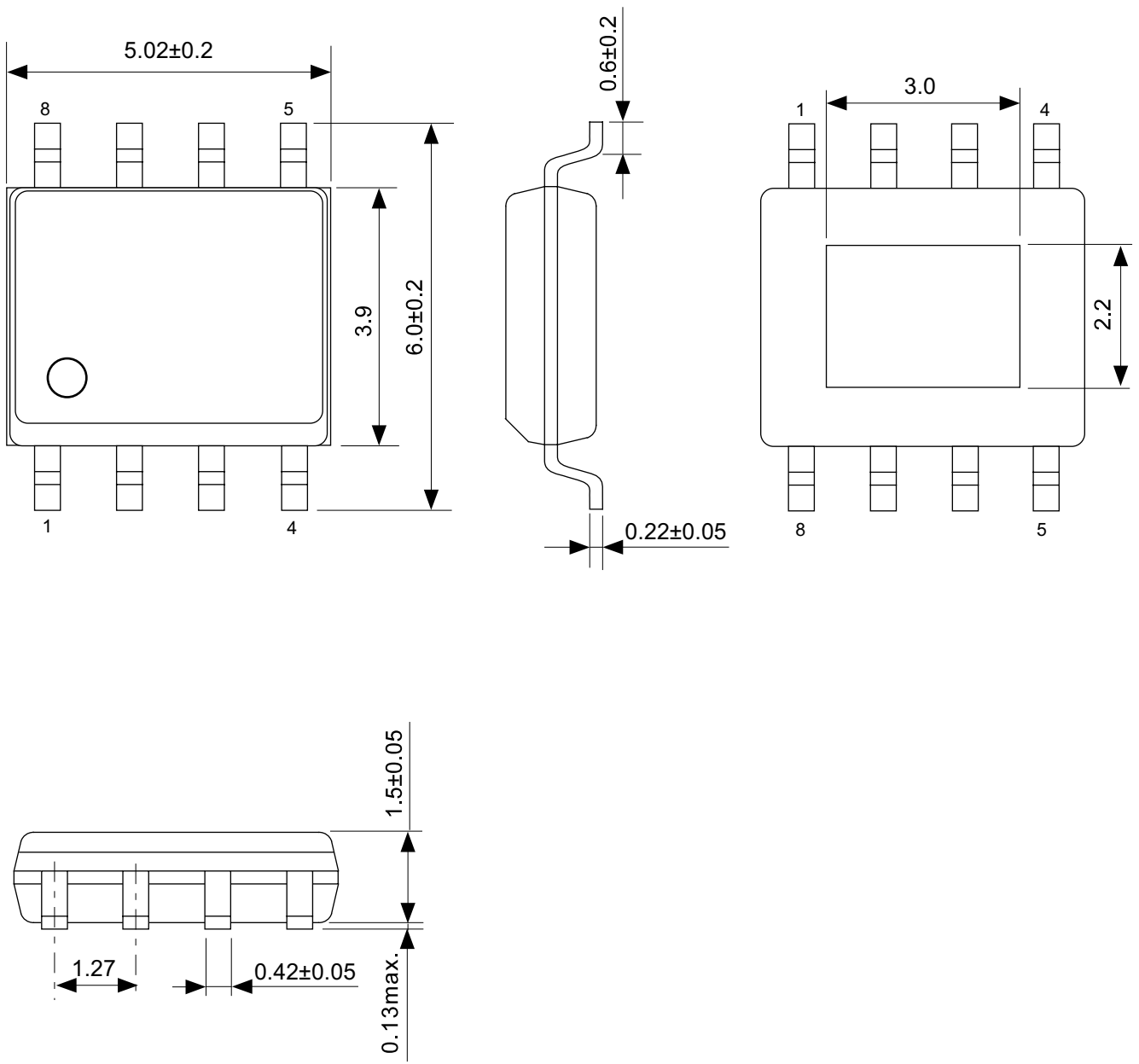

No. FU008-A-P-SD-1.0

TITLE	HSOP8Q-A-PKG Dimensions
No.	FU008-A-P-SD-1.0
ANGLE	
UNIT	mm
ABLIC Inc.	

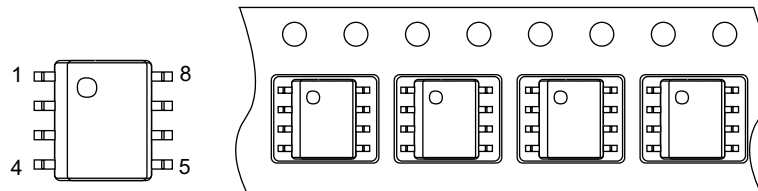
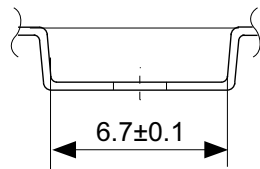
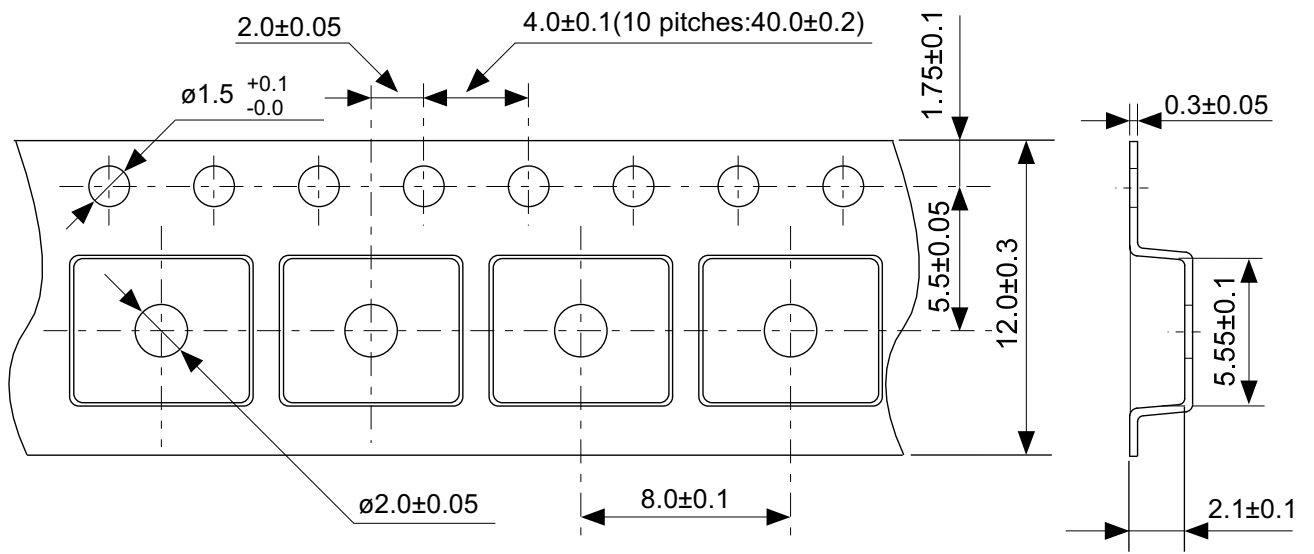

No. FU008-A-C-SD-1.0

TITLE	HSOP8Q-A-Carrier Tape
No.	FU008-A-C-SD-1.0
ANGLE	
UNIT	mm
ABLIC Inc.	

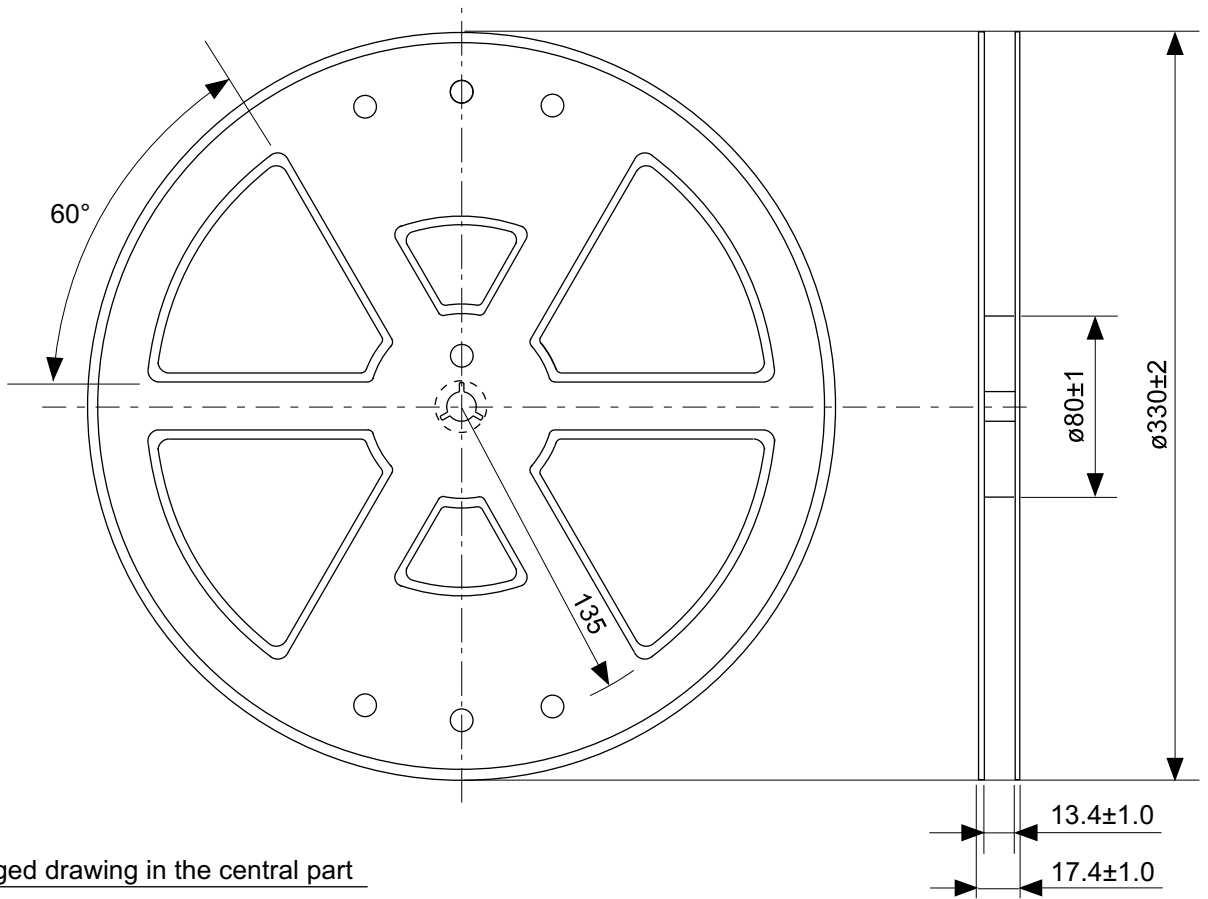

Enlarged drawing in the central part

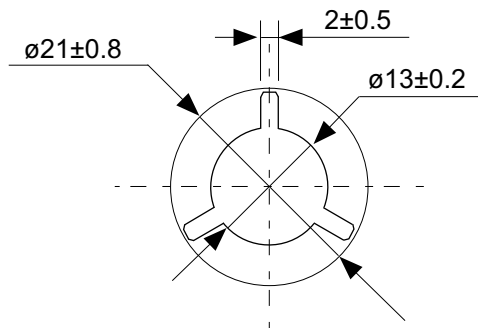

No. FU008-A-R-SD-1.0

TITLE	HSOP8Q-A-Reel		
No.	FU008-A-R-SD-1.0		
ANGLE		QTY.	4,000
UNIT	mm		
ABLIC Inc.			

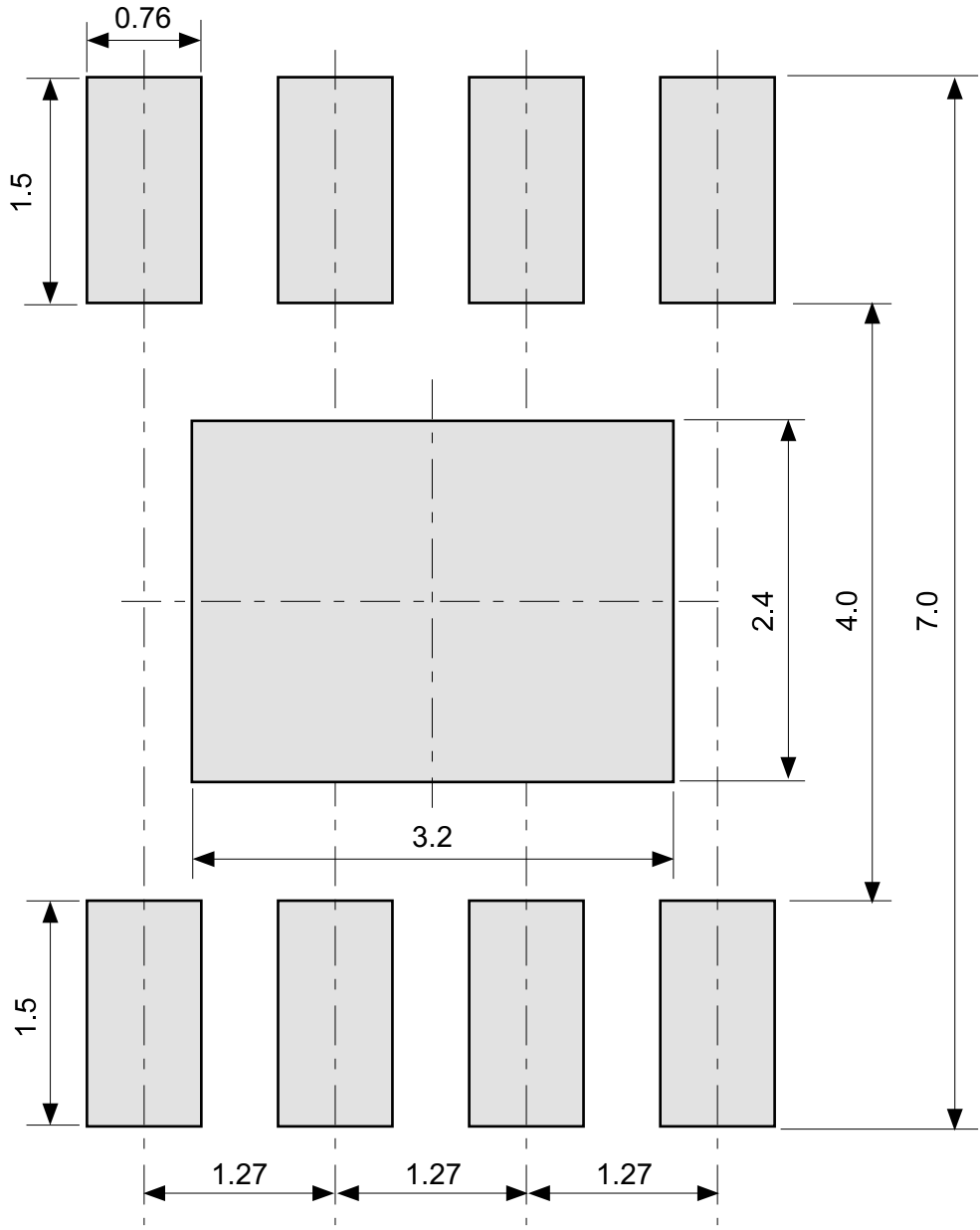

No. FU008-A-L-SD-1.0

TITLE	HSOP8Q-A -Land Recommendation
No.	FU008-A-L-SD-1.0
ANGLE	
UNIT	mm
ABLIC Inc.	

Disclaimers (Handling Precautions)

1. All the information described herein (product data, specifications, figures, tables, programs, algorithms and application circuit examples, etc.) is current as of publishing date of this document and is subject to change without notice.
2. The circuit examples and the usages described herein are for reference only, and do not guarantee the success of any specific mass-production design.
ABLIC Inc. is not responsible for damages caused by the reasons other than the products described herein (hereinafter "the products") or infringement of third-party intellectual property right and any other right due to the use of the information described herein.
3. ABLIC Inc. is not responsible for damages caused by the incorrect information described herein.
4. Be careful to use the products within their specified ranges. Pay special attention to the absolute maximum ratings, operation voltage range and electrical characteristics, etc.
ABLIC Inc. is not responsible for damages caused by failures and / or accidents, etc. that occur due to the use of the products outside their specified ranges.
5. When using the products, confirm their applications, and the laws and regulations of the region or country where they are used and verify suitability, safety and other factors for the intended use.
6. When exporting the products, comply with the Foreign Exchange and Foreign Trade Act and all other export-related laws, and follow the required procedures.
7. The products must not be used or provided (exported) for the purposes of the development of weapons of mass destruction or military use. ABLIC Inc. is not responsible for any provision (export) to those whose purpose is to develop, manufacture, use or store nuclear, biological or chemical weapons, missiles, or other military use.
8. The products are not designed to be used as part of any device or equipment that may affect the human body, human life, or assets (such as medical equipment, disaster prevention systems, security systems, combustion control systems, infrastructure control systems, vehicle equipment, traffic systems, in-vehicle equipment, aviation equipment, aerospace equipment, and nuclear-related equipment), excluding when specified for in-vehicle use or other uses. Do not apply the products to the above listed devices and equipments without prior written permission by ABLIC Inc. Especially, the products cannot be used for life support devices, devices implanted in the human body and devices that directly affect human life, etc.
Prior consultation with our sales office is required when considering the above uses.
ABLIC Inc. is not responsible for damages caused by unauthorized or unspecified use of our products.
9. Semiconductor products may fail or malfunction with some probability.
The user of the products should therefore take responsibility to give thorough consideration to safety design including redundancy, fire spread prevention measures, and malfunction prevention to prevent accidents causing injury or death, fires and social damage, etc. that may ensue from the products' failure or malfunction.
The entire system must be sufficiently evaluated and applied on customer's own responsibility.
10. The products are not designed to be radiation-proof. The necessary radiation measures should be taken in the product design by the customer depending on the intended use.
11. The products do not affect human health under normal use. However, they contain chemical substances and heavy metals and should therefore not be put in the mouth. The fracture surfaces of wafers and chips may be sharp. Be careful when handling these with the bare hands to prevent injuries, etc.
12. When disposing of the products, comply with the laws and ordinances of the country or region where they are used.
13. The information described herein contains copyright information and know-how of ABLIC Inc.
The information described herein does not convey any license under any intellectual property rights or any other rights belonging to ABLIC Inc. or a third party. Reproduction or copying of the information from this document or any part of this document described herein for the purpose of disclosing it to a third-party without the express permission of ABLIC Inc. is strictly prohibited.
14. For more details on the information described herein, contact our sales office.

2.0-2018.01