

The convenience timer is a CMOS timer IC which operates with low current consumption, and is suitable for the time management of the relative time.

The S-35720 Series compares the timer value and the value set to the SET0 pin and the SET1 pin, and outputs an interrupt signal when the values match each other.

The timer is a 24-bit binary-up counter.

4 types of interrupt time can be selected depending on the SET0 pin and the SET1 pin settings.

Caution This product can be used in vehicle equipment and in-vehicle equipment. Before using the product in the purpose, contact to ABLIC Inc. is indispensable.

■ Features

- Alarm interrupt function: Settable interrupt time
 Selectable as the option on the second time scale from 1 second to 194 days
 (Approximately half a year)
- Low current consumption: 0.2 μ A typ. (Quartz crystal: $C_L = 6.0$ pF, $V_{DD} = 3.0$ V, $T_a = +25^\circ\text{C}$)
- Wide range of operation voltage: 1.8 V to 5.5 V
- Built-in 32.768 kHz crystal oscillation circuit
- Operation temperature range: $T_a = -40^\circ\text{C}$ to $+125^\circ\text{C}$
- Lead-free (Sn 100%), halogen-free
- AEC-Q100 qualified^{*1}

*1. Contact our sales office for details.

■ Application

- Time management of various systems during the sleep period

■ Package

- TMSOP-8

■ **Block Diagram**

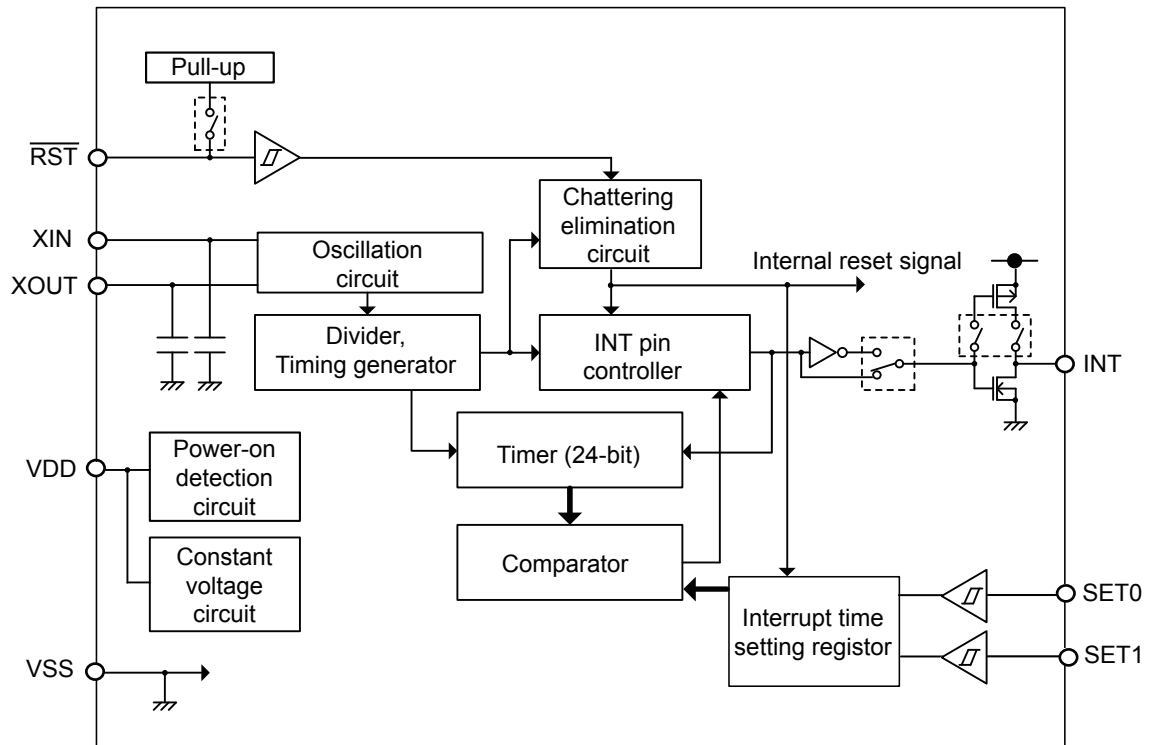

Figure 1

■ AEC-Q100 Qualified

This IC supports AEC-Q100 for operation temperature grade 1.
Contact our sales office for details of AEC-Q100 reliability specification.

■ Product Name Structure

1. Product name

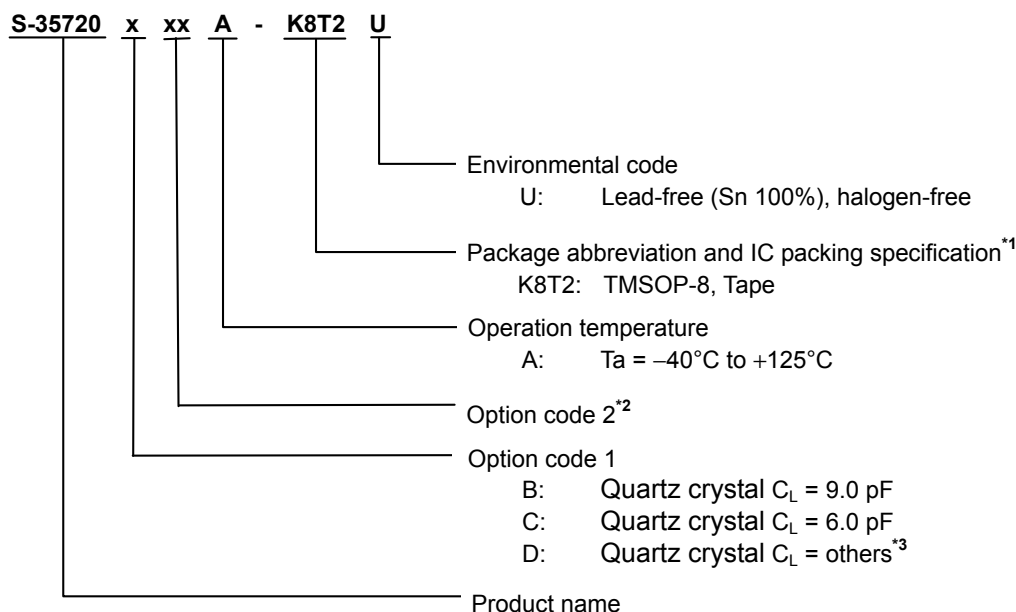

- *1. Refer to the tape drawing.
- *2. A sequence number added by the optional function that is user-selected.
- *3. Contact our sales office for details.

2. Package

Table 1 Package Drawing Codes

Package Name	Dimension	Tape	Reel
TMSOP-8	FM008-A-P-SD	FM008-A-C-SD	FM008-A-R-SD

3. Product name list

Table 2 (1 / 2)

Product Name	RST Pin*1	INT Pin Output Form*2	Time-out Type*3
S-35720C01A-K8T2U	With pull-up resistor	Nch open-drain output	One-shot loop time-out (7.8 ms*4)
S-35720C02A-K8T2U	With pull-up resistor	CMOS output	One-shot loop time-out (125 ms*4)

Table 2 (2 / 2)

Product Name	SET0 Pin, SET1 Pin Settings (SET0, SET1)			
	0, 0	0, 1	1, 0	1, 1
S-35720C01A-K8T2U	60 seconds	10 seconds	30 seconds	1 second
S-35720C02A-K8T2U	60 seconds	10 seconds	30 seconds	1 second

- *1. The pin with / without pull-up resistor is selectable. Refer to "■ Pin Functions".
- *2. The pin of Nch open-drain output / CMOS output is selectable. Refer to "■ Pin Functions".
- *3. The type of one-shot loop time-out / handshake time-out / toggle operation is selectable. Refer to "■ INT Pin Interrupt Signal Output". Contact our sales office for the details of toggle operation.
- *4. Pulse widths when "one-shot loop time-out" is selected. Refer to "■ INT Pin Interrupt Signal Output".

Remark Please contact our sales office for products with specifications other than the above.

■ Pin Configuration

1. TMSOP-8

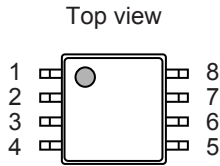

Figure 2

Table 3 List of Pins

Pin No.	Symbol	Description	I/O	Configuration
1	\overline{RST}	Input pin for reset signal	Input	CMOS input (With / without pull-up resistor is selectable)
2	XOUT	Connection pins for quartz crystal	-	-
3	XIN			
4	VSS	GND pin	-	-
5	INT	Output pin for interrupt signal	Output	Nch open-drain output / CMOS output is selectable
6	SET0	Input pins for interrupt time setting	Input	CMOS input
7	SET1			
8	VDD	Pin for positive power supply	-	-

■ Pin Functions

1. SET0, SET1 (Input for interrupt time setting) pins

These pins input the interrupt time setting signal. The setting signals are input when the $\overline{\text{RST}}$ pin changes from "L" to "H". As a result, interrupt time does not change even if the SET0 pin and the SET1 pin change during timer operation. In one-shot loop time-out and handshake time-out, 4 types of interrupt time can be selected depending on the SET0 pin and the SET1 pin settings. Interrupt time of the timer can be selected as the option on the second time scale from 1 second to 194 days (approximately half a year).

2. $\overline{\text{RST}}$ (Input for reset signal) pin

This pin inputs the reset signal. The timer is reset when inputting "L" to the $\overline{\text{RST}}$ pin. The INT pin is set to "H" when inputting "H" to the $\overline{\text{RST}}$ pin, and the timer starts the operation. The $\overline{\text{RST}}$ pin has a built-in chattering elimination circuit. Regarding the chattering elimination circuit, refer to "■ Chattering Elimination of $\overline{\text{RST}}$ Pin". Also, the $\overline{\text{RST}}$ pin with / without pull-up resistor can be selected.

3. INT (Output for interrupt signal) pin

This pin outputs an interrupt signal. The interrupt signal is output when the time set to the SET0 pin and the SET1 pin comes. The interrupt signal output (time-out type) of one-shot loop time-out / handshake time-out / toggle operation*1 can be selected as the option. Regarding the operation of the interrupt signal output, refer to "■ INT Pin Interrupt Signal Output".

Also, the INT pin output form of Nch open-drain output / CMOS output can be selected.

*1. Contact our sales office for the details of toggle operation.

4. XIN, XOUT (Connection for quartz crystal) pins

Connect a quartz crystal between the XIN pin and the XOUT pin.

5. VDD (Positive power supply) pin

Connect this pin with a positive power supply.

Regarding the values of voltage to be supplied, refer to "■ Recommended Operation Conditions".

6. VSS pin

Connect this pin to GND.

■ Equivalent Circuits of Pins

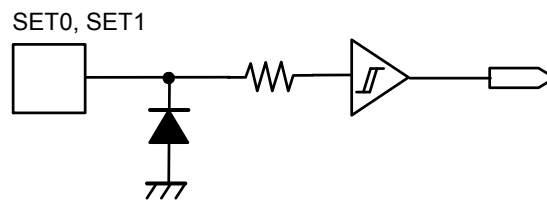

Figure 3 SET0 Pin, SET1 Pin

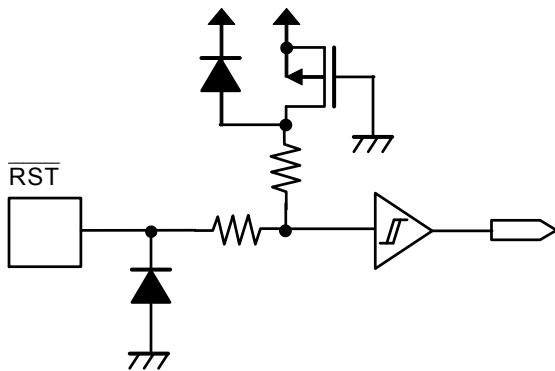

Figure 4 $\overline{\text{RST}}$ Pin (With Pull-up Resistor)

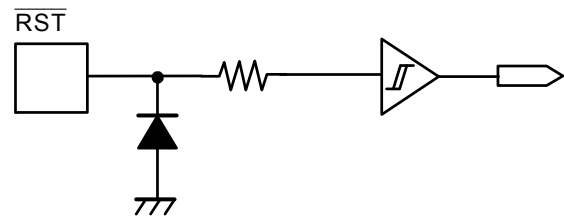

Figure 5 $\overline{\text{RST}}$ Pin (Without Pull-up Resistor)

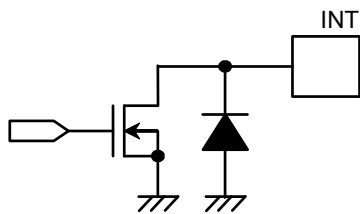

Figure 6 INT Pin (Nch Open-drain Output)

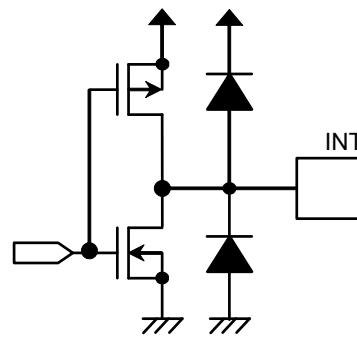

Figure 7 INT Pin (CMOS Output)

■ Absolute Maximum Ratings

Table 4

Item	Symbol	Applied Pin	Absolute Maximum Rating	Unit
Power supply voltage	V _{DD}	–	V _{SS} – 0.3 to V _{SS} + 6.5	V
Input voltage	V _{IN}	SET0, SET1, $\overline{\text{RST}}^{*1}$	V _{SS} – 0.3 to V _{SS} + 6.5	V
		$\overline{\text{RST}}^{*2}$	V _{SS} – 0.3 to V _{DD} + 0.3 ≤ V _{SS} + 6.5	V
Output voltage	V _{OUT}	INT ^{*3}	V _{SS} – 0.3 to V _{SS} + 6.5	V
		INT ^{*4}	V _{SS} – 0.3 to V _{DD} + 0.3 ≤ V _{SS} + 6.5	V
Operation ambient temperature ^{*5}	T _{opr}	–	–40 to +125	°C
Storage temperature	T _{stg}	–	–55 to +150	°C

*1. When a product without a pull-up resistor is selected.

*2. When a product with a pull-up resistor is selected.

*3. When an Nch open-drain output product is selected.

*4. When a CMOS output product is selected.

*5. Conditions with no condensation or frost. Condensation or frost causes short-circuiting between pins, resulting in a malfunction.

Caution The absolute maximum ratings are rated values exceeding which the product could suffer physical damage. These values must therefore not be exceeded under any conditions.

■ Recommended Operation Condition

Table 5

(V_{SS} = 0 V)

Item	Symbol	Condition	Min.	Typ.	Max.	Unit
Operation power supply voltage	V _{DD}	T _a = –40°C to +125°C	1.8	–	5.5	V

■ Oscillation Characteristics

Table 6

(T_a = +25°C, V_{DD} = 3.0 V, V_{SS} = 0 V unless otherwise specified)

(Quartz crystal (NX3215SD, C_L = 6.0 pF) manufactured by Nihon Dempa Kogyo Co., Ltd.)

Item	Symbol	Condition	Min.	Typ.	Max.	Unit
Oscillation start voltage	V _{STA}	Within 10 seconds	1.8	–	5.5	V
Oscillation start time	t _{STA}	–	–	–	1	s
IC-to-IC frequency deviation ^{*1}	δIC	–	–20	–	+20	ppm

*1. Reference value

■ DC Electrical Characteristics

Table 7

(Ta = -40°C to +125°C, V_{SS} = 0 V unless otherwise specified)
(Quartz crystal (NX3215SD, C_L = 6.0 pF) manufactured by Nihon Dempa Kogyo Co., Ltd.)

Item	Symbol	Applied Pin	Condition	Min.	Typ.	Max.	Unit
Current consumption 1	I _{DD1}	-	V _{DD} = 3.0 V, Ta = -40°C to +85°C, $\overline{\text{RST}}$ pin = V _{DD} , INT pin = no load	-	0.2	0.35	μA
			V _{DD} = 3.0 V, Ta = +125°C, $\overline{\text{RST}}$ pin = V _{DD} , INT pin = no load	-	0.7	0.95	μA
High level input leakage current	I _{IZH}	SET0, SET1, $\overline{\text{RST}}$	V _{IN} = V _{DD}	-0.5	-	0.5	μA
Low level input leakage current	I _{IZL}	SET0, SET1, $\overline{\text{RST}}$ *1	V _{IN} = V _{SS}	-0.5	-	0.5	μA
High level output leakage current	I _{OZH}	INT*2	V _{OUT} = V _{DD}	-0.5	-	0.5	μA
Low level output leakage current	I _{OZL}	INT*2	V _{OUT} = V _{SS}	-0.5	-	0.5	μA
High level input voltage	V _{IH}	SET0, SET1, $\overline{\text{RST}}$	-	0.7 × V _{DD}	-	V _{SS} + 5.5	V
Low level input voltage	V _{IL}	SET0, SET1, $\overline{\text{RST}}$	-	V _{SS} - 0.3	-	0.3 × V _{DD}	V
High level output voltage*3	V _{OH}	INT	I _{OH} = -0.4 mA	0.8 × V _{DD}	-	-	V
Low level output voltage	V _{OL}	INT	I _{OL} = 2.0 mA	-	-	0.4	V
Low level input current*4	I _{IL}	$\overline{\text{RST}}$	V _{DD} = 3.0 V, V _{IN} = V _{SS}	-100	-30	-5	μA

*1. When a product without a pull-up resistor is selected.

*2. When an Nch open-drain output product is selected.

*3. When a CMOS output product is selected.

*4. When a product with a pull-up resistor is selected.

■ INT Pin Interrupt Signal Output

The INT pin interrupt signal output (time-out type) can be selected from one of the following:

- One-shot loop time-out
- Handshake time-out
- Toggle operation ^{*1}

*1. Contact our sales office for the details of toggle operation.

1. One-shot loop time-out

One-shot loop time-out is a type to output the "L" pulse interrupt signal repeatedly from the INT pin. After the $\overline{\text{RST}}$ pin changes from "L" to "H", the timer starts the operation. Then, the INT pin outputs "L" pulse when the timer value matches the value set to the SET0 pin and the SET1 pin^{*1}. After that, the S-35720 Series resets the timer automatically, and restarts a count-up action.

If "L" is input to the $\overline{\text{RST}}$ pin before the timer value matches the value set to the SET0 pin and the SET1 pin^{*1}, the timer is reset.

*1. 4 types of interrupt time can be selected depending on the SET0 pin and the SET1 pin settings.

Remark The above description is the example of an Nch open-drain output product.
 In a CMOS output product, the INT pin output is the inverse logic of the Nch open-drain output product.

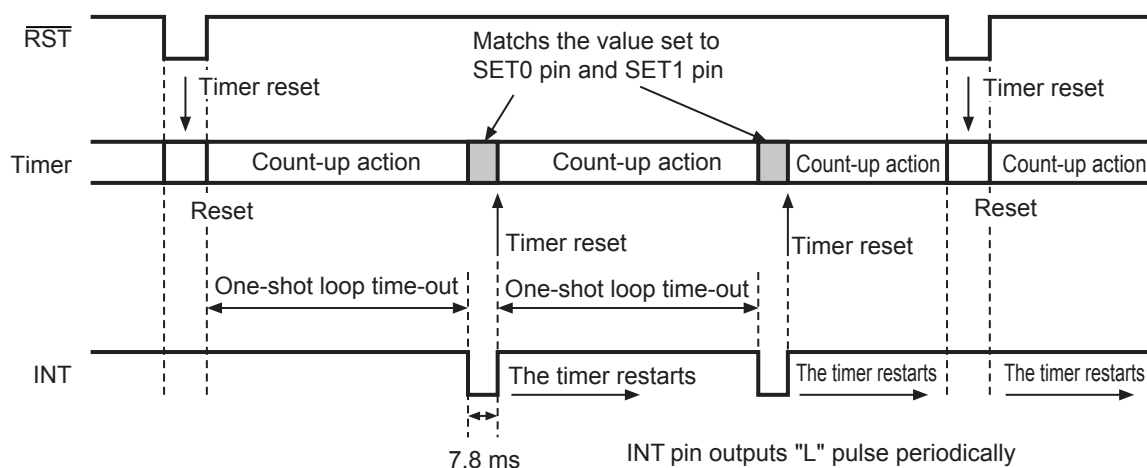

Figure 8 Output Timing of One-shot Loop Time-out (S-35720C01A / Nch Open-drain Output)

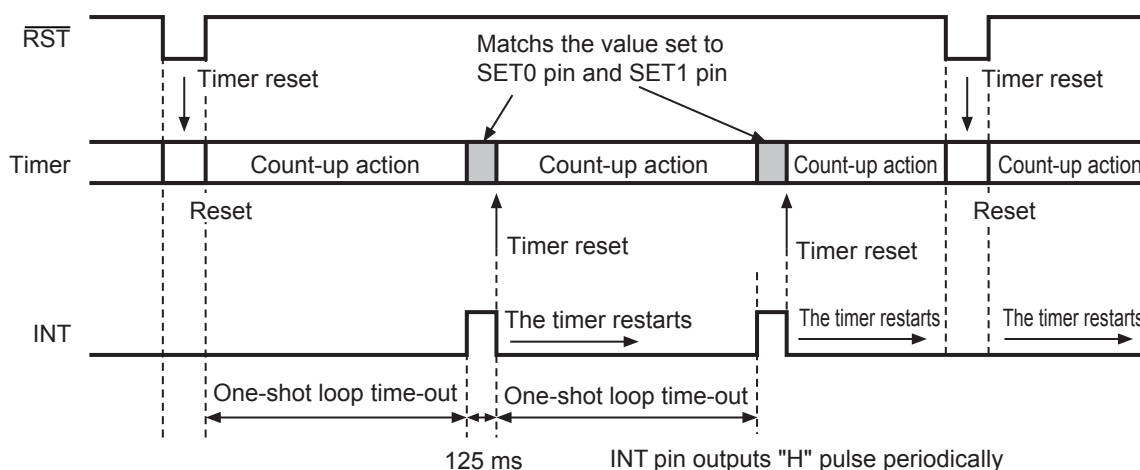

Figure 9 Output Timing of One-shot Loop Time-out (S-35720C02A / CMOS Output)

2. Handshake time-out

Handshake time-out is a type to output "L" level interrupt signal from the INT pin.

After the $\overline{\text{RST}}$ pin changes from "L" to "H", the timer starts the operation. Then, the INT pin outputs "L" level when the timer value matches the value set to the SET0 pin and the SET1 pin^{*1}. When the INT pin outputs "L" level, the timer stops and maintains the timer value.

The timer is reset by inputting "L" to the $\overline{\text{RST}}$ pin. After that, if "H" is input to the $\overline{\text{RST}}$ pin, the INT pin is set to "H" and the timer restarts the count-up action.

If "L" is input to the $\overline{\text{RST}}$ pin before the timer value matches the value set to the SET0 pin and the SET1 pin^{*1}, the timer is reset.

^{*1}. 4 types of interrupt time can be selected depending on the SET0 pin and the SET1 pin settings.

Remark The above description is the example of an Nch open-drain output product.
 In a CMOS output product, the INT pin output is the inverse logic of the Nch open-drain output product.

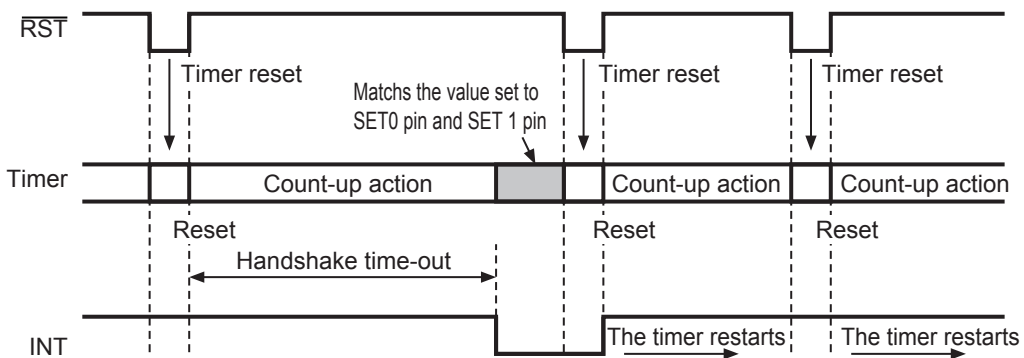

Figure 10 Output Timing of Handshake Time-out (Nch Open-drain Output)

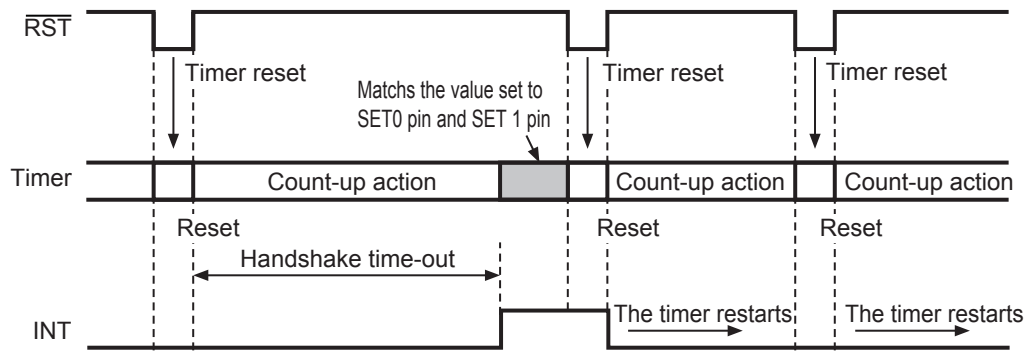
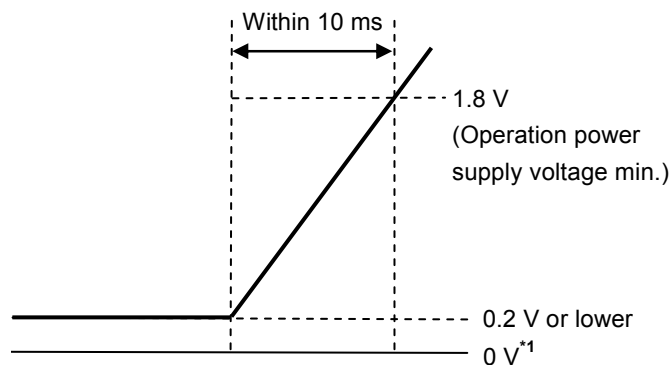

Figure 11 Output Timing of Handshake Time-out (CMOS Output)

■ Power-on Detection Circuit

In order for the power-on detection circuit to operate normally, raise the power supply voltage of the IC from 0.2 V or lower so that it reaches 1.8 V of the operation power supply voltage minimum value within 10 ms, as shown in **Figure 12**.



*1. 0 V means that there is no potential difference between the VDD pin and the VSS pin of the S-35720 Series.

Figure 12 How to Raise the Power Supply Voltage

If the power supply voltage of the S-35720 Series cannot be raised under the above conditions, the power-on detection circuit may not operate normally and an oscillation may not start*1. In such case, perform the operations shown in "1. When power supply voltage is raised at $\overline{\text{RST}}$ pin = "L" " and "2. When power supply voltage is raised at $\overline{\text{RST}}$ pin = "H" ".

*1. When one-shot loop time-out or handshake time-out is selected as the option.

1. When power supply voltage is raised at $\overline{\text{RST}}$ pin = "L"

Set the $\overline{\text{RST}}$ pin to "L" until the power supply voltage reaches 1.8 V or higher. While the $\overline{\text{RST}}$ pin is set to "L", the oscillation start signal becomes "H", and the crystal oscillation circuit normally oscillates. If the $\overline{\text{RST}}$ pin is set to "H" after the power supply voltage reaches 1.8 V, the oscillation start signal becomes "L" within 500 ms, and the oscillation status is maintained.

The current consumption increases as mentioned below while the $\overline{\text{RST}}$ pin is set to "L".

- When a product without a pull-up resistor is selected: 1.7 μA typ.
- When a product with a pull-up resistor is selected: 30 μA typ.

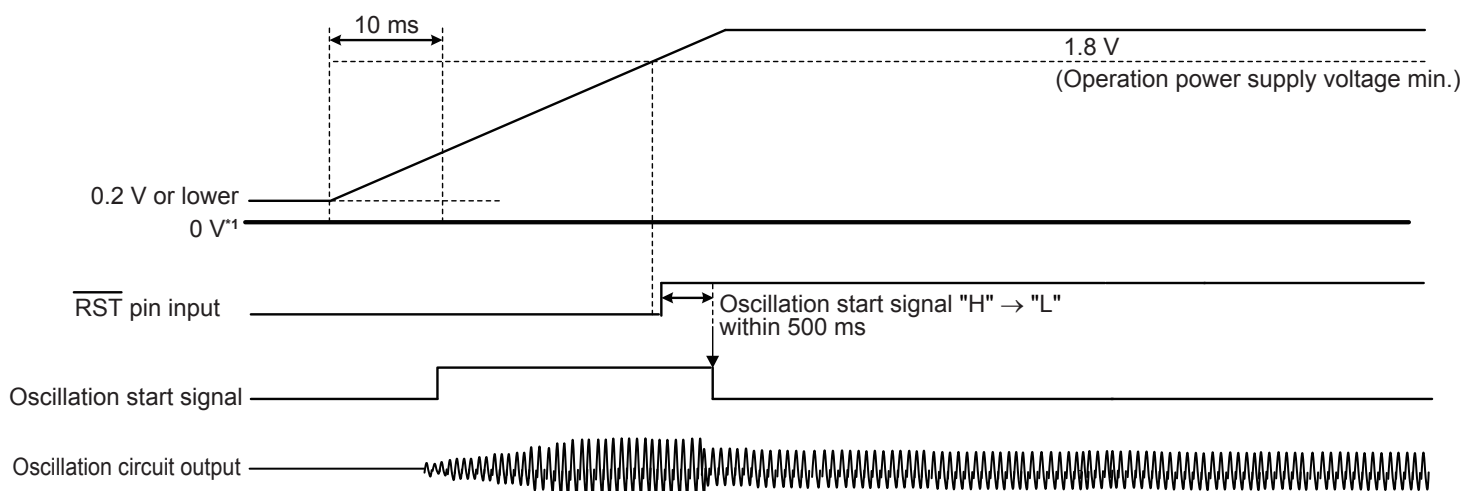

*1. 0 V means that there is no potential difference between the VDD pin and the VSS pin of the S-35720 Series.

Figure 13 When Power Supply Voltage is Raised at $\overline{\text{RST}}$ Pin = "L"

2. When power supply voltage is raised at $\overline{\text{RST}}$ pin = "H"

Set the $\overline{\text{RST}}$ pin to "L" after the power supply voltage reaches 1.8 V or higher. If the $\overline{\text{RST}}$ pin is set to "L" for 500 ms or longer, the oscillation start signal becomes "H", and the crystal oscillation circuit normally oscillates. After that, if the $\overline{\text{RST}}$ pin is set to "H", the oscillation start signal becomes "L" within 500 ms, and the oscillation status is maintained. The current consumption increases as mentioned below while the $\overline{\text{RST}}$ pin is set to "L".

- When a product without a pull-up resistor is selected: 1.7 μA typ.
- When a product with a pull-up resistor is selected: 30 μA typ.

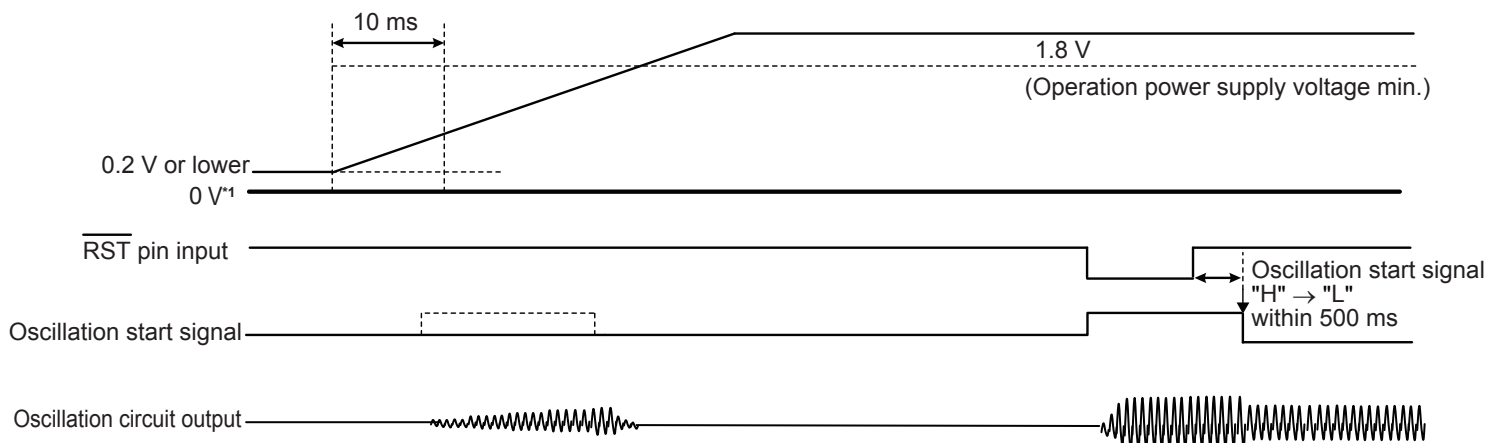

*1. 0 V means that there is no potential difference between the VDD pin and the VSS pin of the S-35720 Series.

Figure 14 When Power Supply Voltage is Raised at $\overline{\text{RST}}$ Pin = "H"

The $\overline{\text{RST}}$ pin has a built-in chattering elimination circuit.

Regarding the chattering elimination of the $\overline{\text{RST}}$ pin, refer to "■ Chattering Elimination of $\overline{\text{RST}}$ Pin".

■ Chattering Elimination of $\overline{\text{RST}}$ Pin

The $\overline{\text{RST}}$ pin has a built-in chattering elimination circuit, and the output logic is active "L".

Figure 15 is a timing chart of chattering elimination. Perform sampling at 8 Hz and operate the shift register circuit. Perform the shift operation for 3 times, and reset the counter when DF1 to DF3 are all "L". During the chattering elimination, the pulse width, 2 periods (approximately 0.25 seconds) of clock (8 Hz), can be eliminated. To determine the $\overline{\text{RST}}$ pin "L" input, maintain the $\overline{\text{RST}}$ pin "L" input during the period longer than 3.5 periods (0.438 seconds) of clock (8 Hz). Similarly, to determine the $\overline{\text{RST}}$ pin "H" input, maintain the $\overline{\text{RST}}$ pin "H" input during the period longer than 3.5 periods (0.438 seconds) of clock (8 Hz).

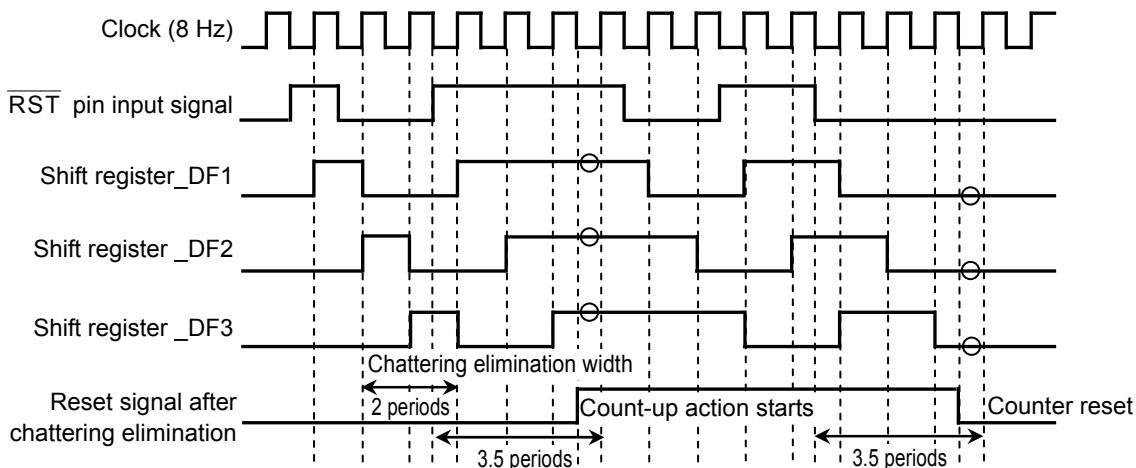
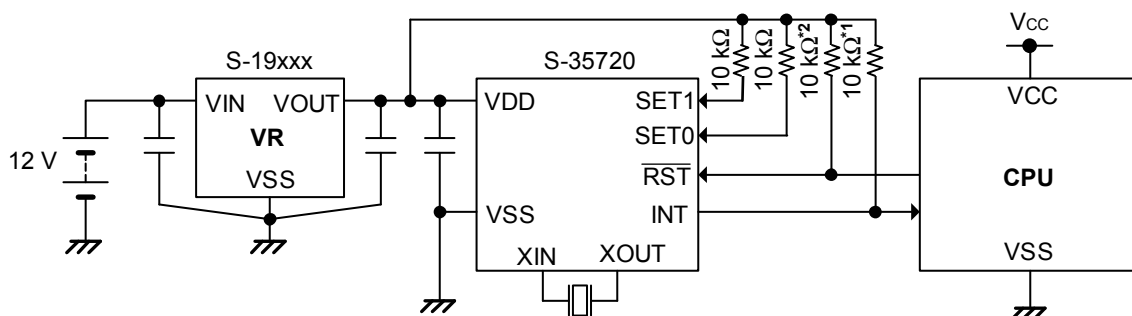

Figure 15 Timing Chart of Chattering Elimination

■ Examples of Application Circuit



- *1. This resistor is unnecessary when a CMOS output product is selected.
- *2. This resistor is unnecessary when a product with a pull-up resistor is selected.

Figure 16

Caution The above connection diagram does not guarantee operation. Set the constants after performing sufficient evaluation using the actual application.

■ Configuration of Crystal Oscillation Circuit

Since the S-35720 Series has built-in capacitors (C_g and C_d), adjustment of oscillation frequency is unnecessary. However, the crystal oscillation circuit is sensitive to external noise and parasitic capacitance (C_P), these effects may become a factor to worsen the clock accuracy. Therefore, the following steps are recommended for optimizing the configuration of crystal oscillation circuit.

- Locate the bypass capacitor adjacent to the power supply pin of the S-35720 Series.
- Place the S-35720 Series and the quartz crystal as close to each other as possible, and shorten the wiring.
- Increase the insulation resistance between pins and the board wiring patterns of XIN and XOUT.
- Do not place any signal or power lines close to the crystal oscillation circuit.
- Locate the GND layer immediately below the crystal oscillation circuit.
 (In the case of a multi-layer board, only the layer farthest from the crystal oscillation circuit should be located as the GND layer. Do not locate a circuit pattern on the intermediate layers.)

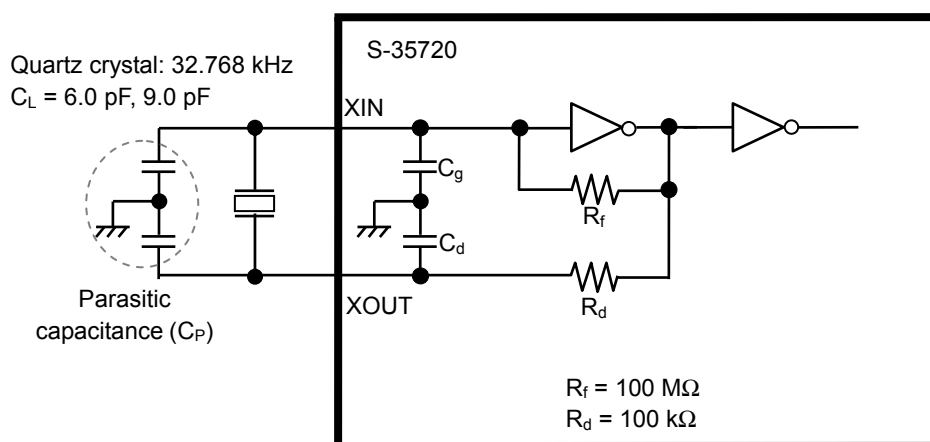

Figure 17 Configuration of Crystal Oscillation Circuit

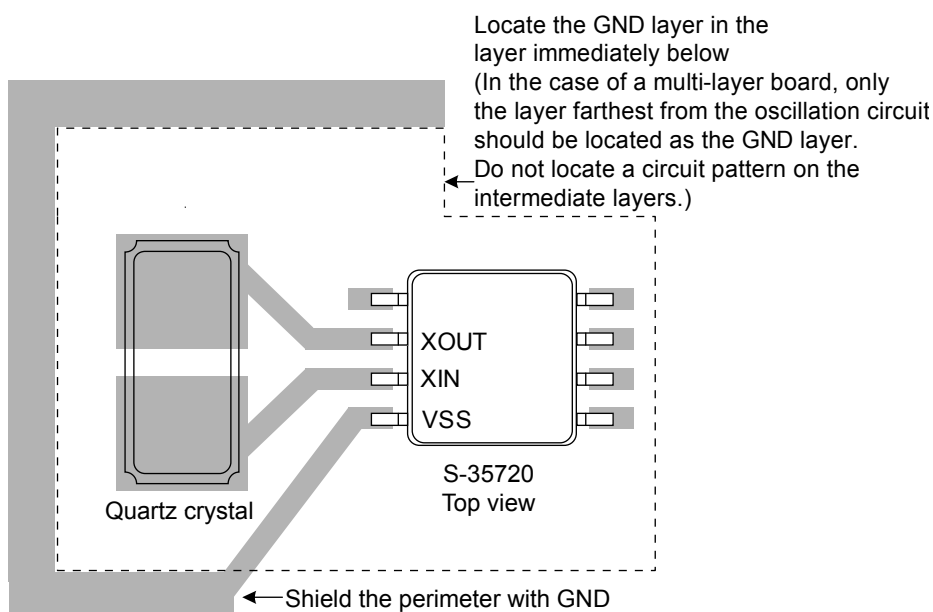

Figure 18 Example of Recommended Connection Pattern Diagram

- Caution**
1. Oscillation characteristics are subject to the variation of each component such as board parasitic capacitance, parasitic resistance, quartz crystal, and external capacitor. When configuring crystal oscillation circuit, pay sufficient attention for them.
 2. When using the product in automobile equipment, select the components which can be automobile carried for each component such as quartz crystal, external capacitor, and board.

■ **Cautions When Using Quartz Crystal**

Request a matching evaluation between the IC and a quartz crystal to the quartz crystal maker.

Refer to **Table 8** for recommended quartz crystal characteristics values. When using the product in an environment over Ta = +85°C, it is recommended to ensure the oscillation allowance shown in **Table 8** at room temperature.

Table 8 Quartz Crystal Characteristics

Quartz Crystal C_L Value (Load Capacitance)	R_1 Value (Equivalent Series Resistance)	Oscillation Allowance at Power-on
9.0 pF	80 kΩ max.	5 times or more
6.0 pF	80 kΩ max.	5 times or more

■ **Precautions**

- Do not apply an electrostatic discharge to this IC that exceeds the performance ratings of the built-in electrostatic protection circuit.
- ABLIC Inc. claims no responsibility for any disputes arising out of or in connection with any infringement by products including this IC of patents owned by a third party.

■ Characteristics (Typical Data)

1. Current consumption 1 vs. Power supply voltage characteristics

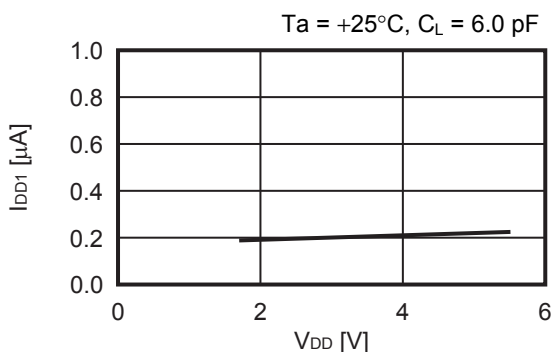

2. Current consumption 1 vs. Temperature characteristics

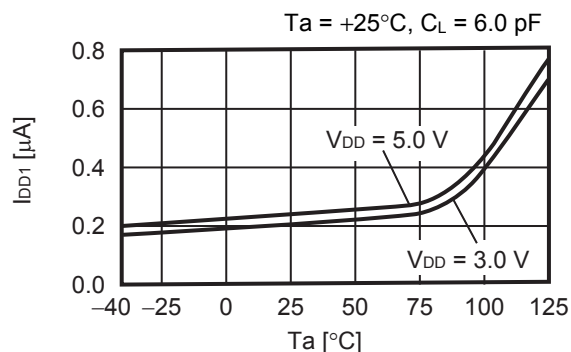

3. Oscillation frequency vs. Power supply voltage characteristics

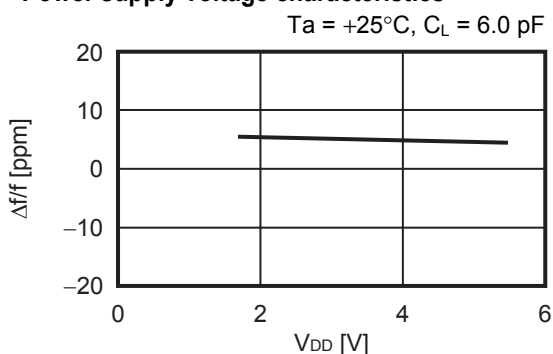

4. Oscillation frequency vs. Temperature characteristics

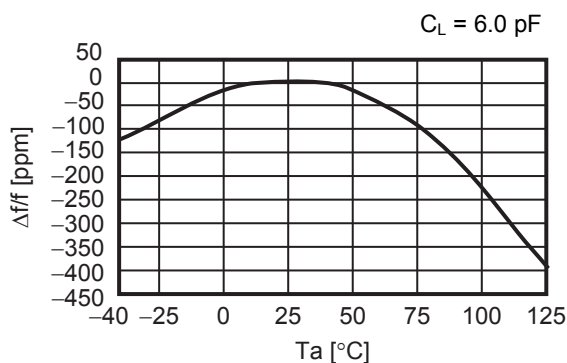

5. Low level output current vs. Output voltage characteristics

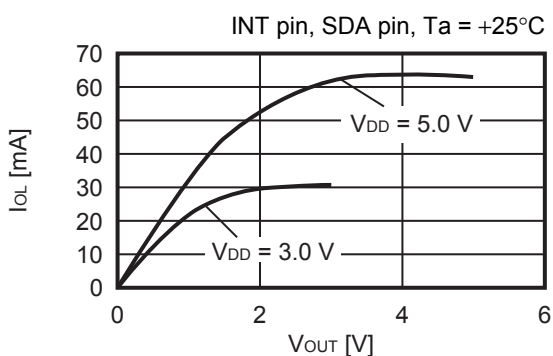

6. High level output current vs. V_DD - V_OUT characteristics

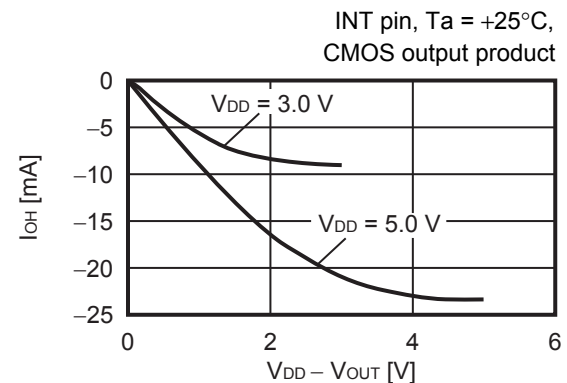

7. Low level input current vs. Power supply voltage characteristics

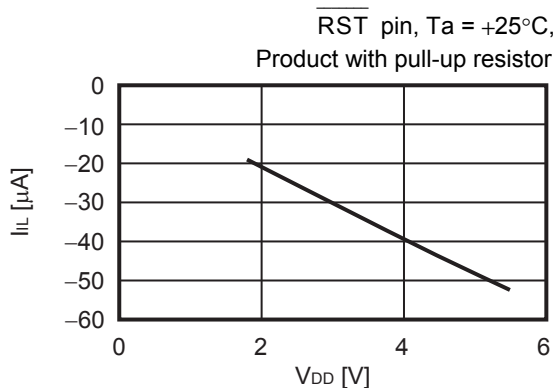

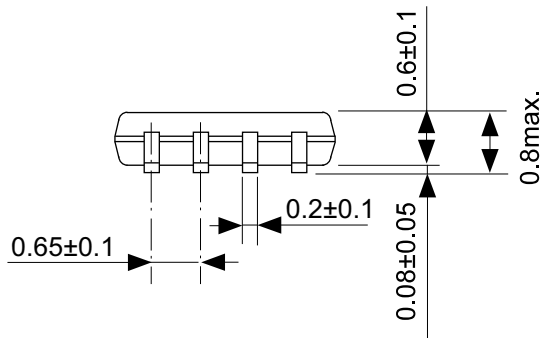
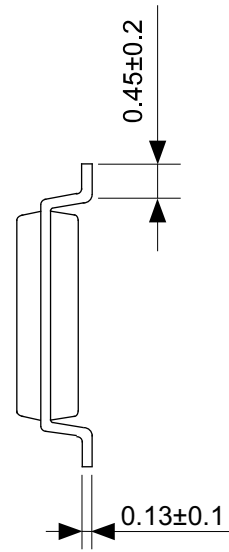
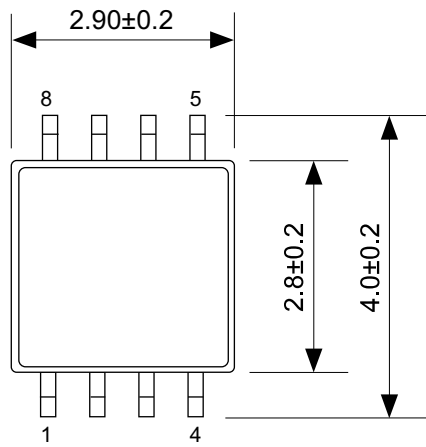

No. FM008-A-P-SD-1.2

TITLE	TMSOP8-A-PKG Dimensions
No.	FM008-A-P-SD-1.2
ANGLE	
UNIT	mm
ABLIC Inc.	

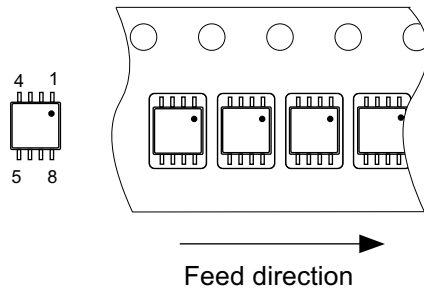
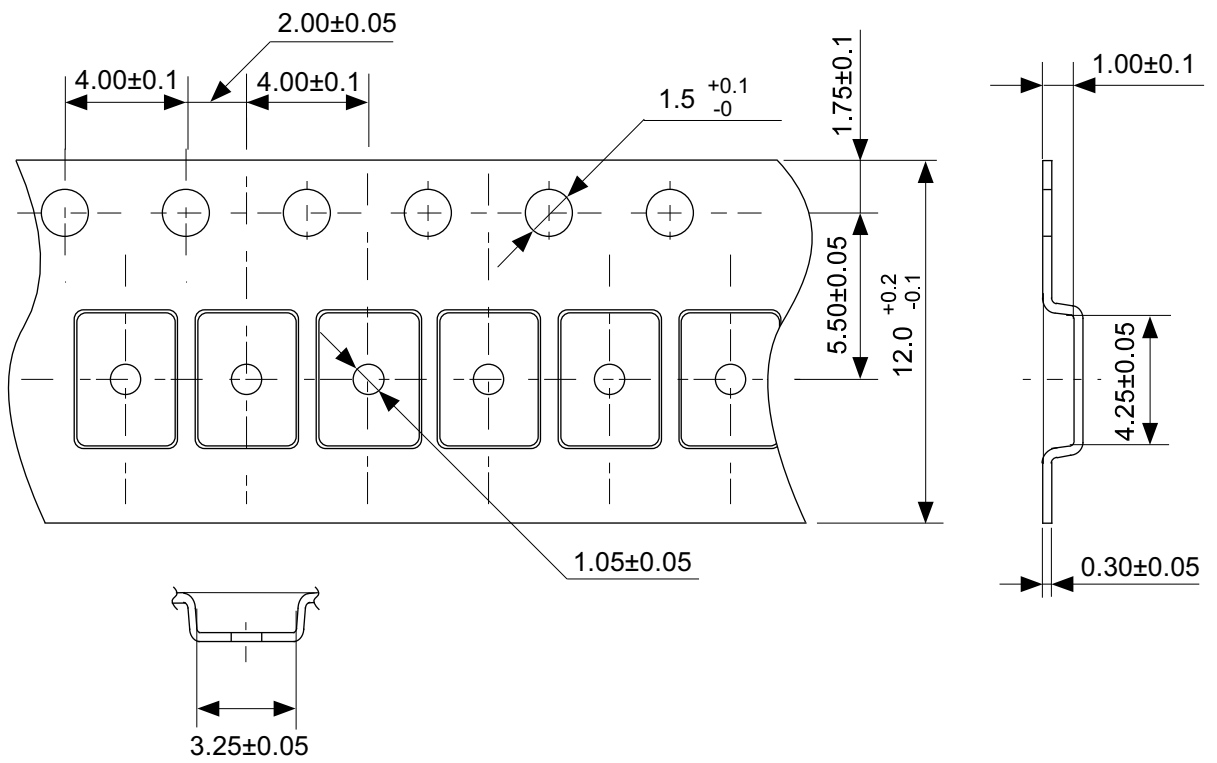

No. FM008-A-C-SD-2.0

TITLE	TMSOP8-A-Carrier Tape
No.	FM008-A-C-SD-2.0
ANGLE	
UNIT	mm
ABLIC Inc.	

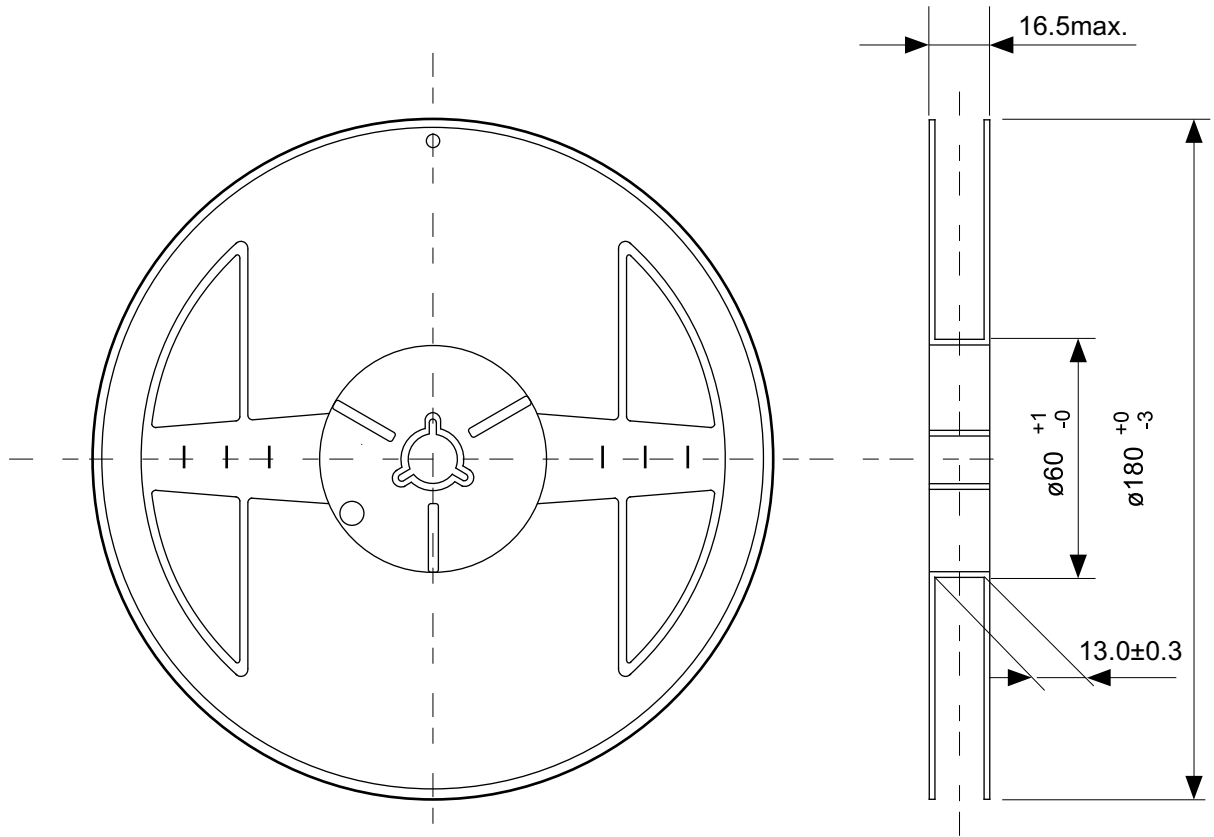

Enlarged drawing in the central part

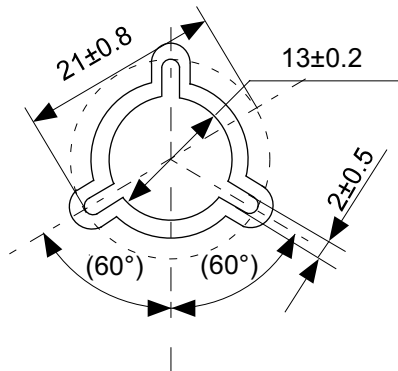

No. FM008-A-R-SD-1.0

TITLE	TMSOP8-A-Reel		
No.	FM008-A-R-SD-1.0		
ANGLE		QTY.	4,000
UNIT	mm		
ABLIC Inc.			

Disclaimers (Handling Precautions)

1. All the information described herein (product data, specifications, figures, tables, programs, algorithms and application circuit examples, etc.) is current as of publishing date of this document and is subject to change without notice.
2. The circuit examples and the usages described herein are for reference only, and do not guarantee the success of any specific mass-production design.
ABLIC Inc. is not responsible for damages caused by the reasons other than the products described herein (hereinafter "the products") or infringement of third-party intellectual property right and any other right due to the use of the information described herein.
3. ABLIC Inc. is not responsible for damages caused by the incorrect information described herein.
4. Be careful to use the products within their specified ranges. Pay special attention to the absolute maximum ratings, operation voltage range and electrical characteristics, etc.
ABLIC Inc. is not responsible for damages caused by failures and / or accidents, etc. that occur due to the use of the products outside their specified ranges.
5. When using the products, confirm their applications, and the laws and regulations of the region or country where they are used and verify suitability, safety and other factors for the intended use.
6. When exporting the products, comply with the Foreign Exchange and Foreign Trade Act and all other export-related laws, and follow the required procedures.
7. The products must not be used or provided (exported) for the purposes of the development of weapons of mass destruction or military use. ABLIC Inc. is not responsible for any provision (export) to those whose purpose is to develop, manufacture, use or store nuclear, biological or chemical weapons, missiles, or other military use.
8. The products are not designed to be used as part of any device or equipment that may affect the human body, human life, or assets (such as medical equipment, disaster prevention systems, security systems, combustion control systems, infrastructure control systems, vehicle equipment, traffic systems, in-vehicle equipment, aviation equipment, aerospace equipment, and nuclear-related equipment), excluding when specified for in-vehicle use or other uses. Do not apply the products to the above listed devices and equipments without prior written permission by ABLIC Inc. Especially, the products cannot be used for life support devices, devices implanted in the human body and devices that directly affect human life, etc.
Prior consultation with our sales office is required when considering the above uses.
ABLIC Inc. is not responsible for damages caused by unauthorized or unspecified use of our products.
9. Semiconductor products may fail or malfunction with some probability.
The user of the products should therefore take responsibility to give thorough consideration to safety design including redundancy, fire spread prevention measures, and malfunction prevention to prevent accidents causing injury or death, fires and social damage, etc. that may ensue from the products' failure or malfunction.
The entire system must be sufficiently evaluated and applied on customer's own responsibility.
10. The products are not designed to be radiation-proof. The necessary radiation measures should be taken in the product design by the customer depending on the intended use.
11. The products do not affect human health under normal use. However, they contain chemical substances and heavy metals and should therefore not be put in the mouth. The fracture surfaces of wafers and chips may be sharp. Be careful when handling these with the bare hands to prevent injuries, etc.
12. When disposing of the products, comply with the laws and ordinances of the country or region where they are used.
13. The information described herein contains copyright information and know-how of ABLIC Inc.
The information described herein does not convey any license under any intellectual property rights or any other rights belonging to ABLIC Inc. or a third party. Reproduction or copying of the information from this document or any part of this document described herein for the purpose of disclosing it to a third-party without the express permission of ABLIC Inc. is strictly prohibited.
14. For more details on the information described herein, contact our sales office.

2.0-2018.01