

The S-5420 is a photodiode (PD) made of silicon that can detect ultraviolet light at high sensitivity. The output current changes in reaction to light which includes ultraviolet light. Therefore, the S-5420 can detect light intensity of various light sources for LEDs and other devices. Since the S-5420 can detect ultraviolet light intensity, it is particularly well suited for use in various light measurement devices which irradiate ultraviolet light.

The S-5420 is composed of two types of ultraviolet photodiodes, a high-sensitivity and a low-sensitivity photodiodes. Using an external circuit, the S-5420 takes the difference of output between the high-sensitivity and low-sensitivity photodiodes, which cuts out visible light components. It results in ultraviolet components detection.

Incorporating a surface-mounting type, small, transparent package, the S-5420 allows for high-density mounting.

**Remark** This product is jointly developed with Sugawa and Kuroda Laboratory of Graduate School of Engineering, Tohoku University.

## ■ Features

- Wide-range sensitivity wavelength:  $\lambda = 250 \text{ nm to } 1000 \text{ nm}$
- High-sensitivity ultraviolet light detection:  $S_H = 0.17 \text{ A/W } (\lambda = 365 \text{ nm})$
- Ultraviolet components detection: As a result of the difference of output between two types of photodiodes (Requirement: external parts)
- Lead-free, halogen-free

## ■ Applications

- Light intensity detection of ultraviolet light source
- UV index detection
- Analytical equipment

## ■ Package

- SON-6C

■ Block Diagram

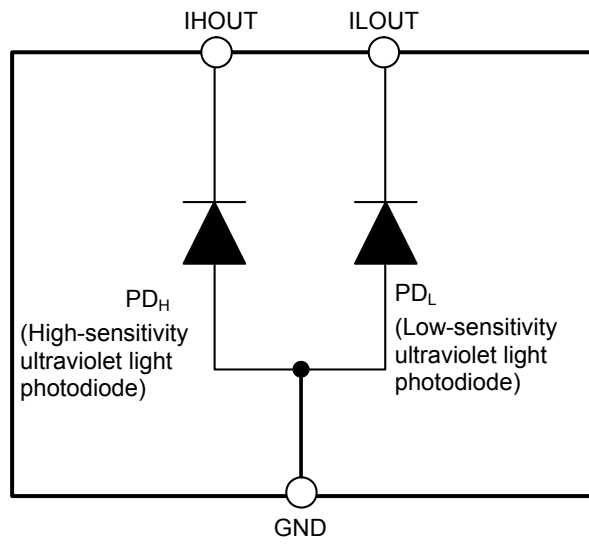
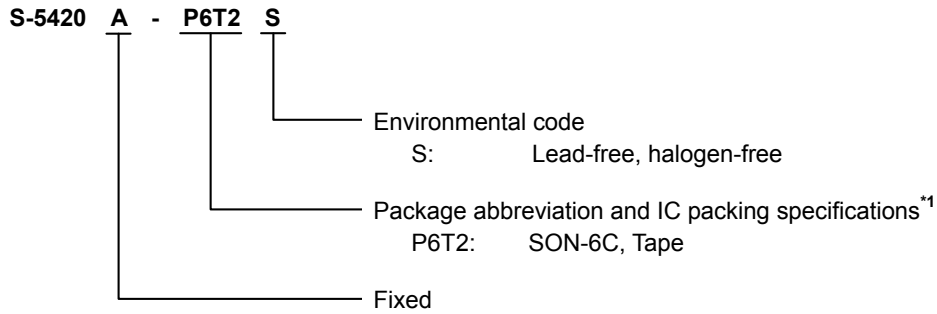

Figure 1

■ Product Name Structure

1. Product name



\*1. Refer to the tape drawing.

2. Package

Table 1 Package Drawing Codes

| Package Name | Dimension    | Tape         | Reel         |
|--------------|--------------|--------------|--------------|
| SON-6C       | PZ006-A-P-SD | PZ006-A-C-SD | PZ006-A-R-SD |

■ Pin Configuration

1. SON-6C

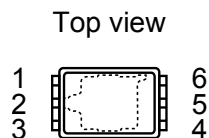

Figure 2

Table 2

| Pin No. | Symbol | Description   |
|---------|--------|---|
| 1       | GND    | GND pin   |
| 2       | NC*1   | No connection   |
| 3       | NC*1   | No connection   |
| 4       | ILOUT  | Output pin<br>(low-sensitivity ultraviolet light PD)  |
| 5       | NC*1   | No connection   |
| 6       | IHOOUT | Output pin<br>(high-sensitivity ultraviolet light PD) |

\*1. The NC pin is electrically open.  
 The NC pin can be connected to the GND pin.

■ Absolute Maximum Ratings

Table 3

(Ta = +25°C unless otherwise specified)

| Item                            | Symbol       | Absolute Maximum Rating | Unit |
|---------------------------------|--------------|-------------------------|------|
| Reverse voltage                 | $V_{R\_max}$ | 4.0                     | V    |
| Operation ambient temperature*1 | $T_{opr}$    | -20 to +70              | °C   |
| Storage temperature*1           | $T_{stg}$    | -40 to +85              | °C   |

\*1. Conditions with no condensation or frost.

**Caution** The absolute maximum ratings are rated values exceeding which the product could suffer physical damage. These values must therefore not be exceeded under any conditions.

■ Electrical Characteristics

Table 4

(When mounted on board, Ta = +25°C unless otherwise specified)

| Item   | Symbol                       | Condition   | Min.                                      | Typ.  | Max. | Unit            |
|--|------------------------------|---|---|-------|------|-----------------|
| Light receiving area (one photodiode)                  | A                            | –   | –   | 0.20  | –    | mm <sup>2</sup> |
| Output pin voltage*1                                   | $V_{IHOUT}$ ,<br>$V_{ILOUT}$ | –   | 0   | –     | 0.5  | V               |
| Sensitivity wavelength range                           | $\lambda$                    | $V_{IHOUT} = 0.3\text{ V}$ , $V_{ILOUT} = 0.3\text{ V}$   | 250 to 1000<br>( $\lambda_p^{*2} = 420$ ) |       |      | nm              |
| Sensitivity<br>(high-sensitivity ultraviolet light PD) | $S_H$                        | $V_{IHOUT} = 0.3\text{ V}$ , $V_{ILOUT} = 0.3\text{ V}$<br>$\lambda = 365\text{ nm}$                              | 0.136                                     | 0.170 | –    | A/W             |
| Sensitivity<br>(low-sensitivity ultraviolet light PD)  | $S_L$                        | $V_{IHOUT} = 0.3\text{ V}$ , $V_{ILOUT} = 0.3\text{ V}$<br>$\lambda = 365\text{ nm}$                              | –   | 0.020 | –    | A/W             |
| Differential sensitivity ( $S_H - S_L$ )               | $S_D$                        | $V_{IHOUT} = 0.3\text{ V}$ , $V_{ILOUT} = 0.3\text{ V}$<br>$\lambda = 365\text{ nm}$<br>$\lambda = 520\text{ nm}$ | 0.120                                     | 0.150 | –    | A/W             |
| Dark current   | $I_d$                        | $V_{IHOUT} = 0.3\text{ V}$ , $V_{ILOUT} = 0.3\text{ V}$   | –   | 5     | 300  | pA              |

\*1. Voltage applied to the output pin

\*2.  $\lambda_p$ : Peak sensitivity wavelength

■ Test Circuit

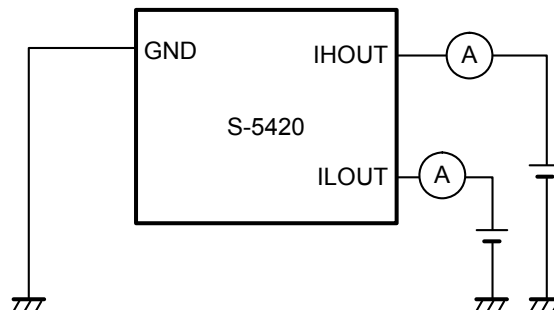

Figure 3

■ Standard Circuits

1. Standard circuit

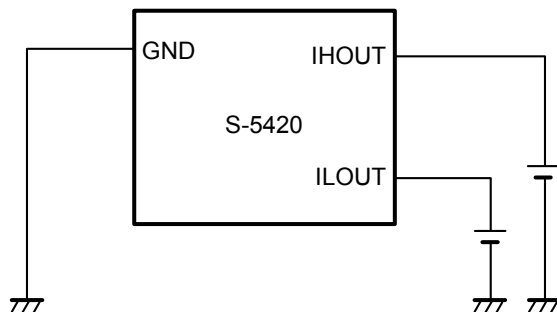

Figure 4

2. Standard circuit when using only high-sensitivity ultraviolet light PD

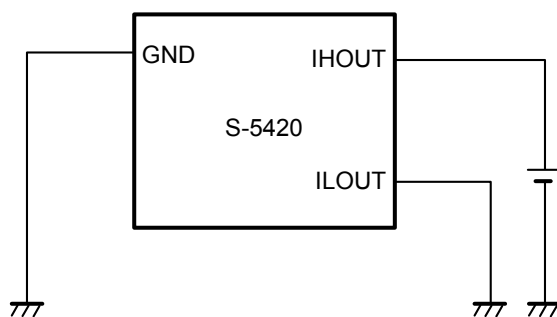

Figure 5

**Caution** The above connection diagrams will not guarantee successful operation.  
Perform thorough evaluation using the actual application to set the constants.

■ Application Circuit

1. I/V conversion circuit

Voltage proportional to the irradiation light is output.

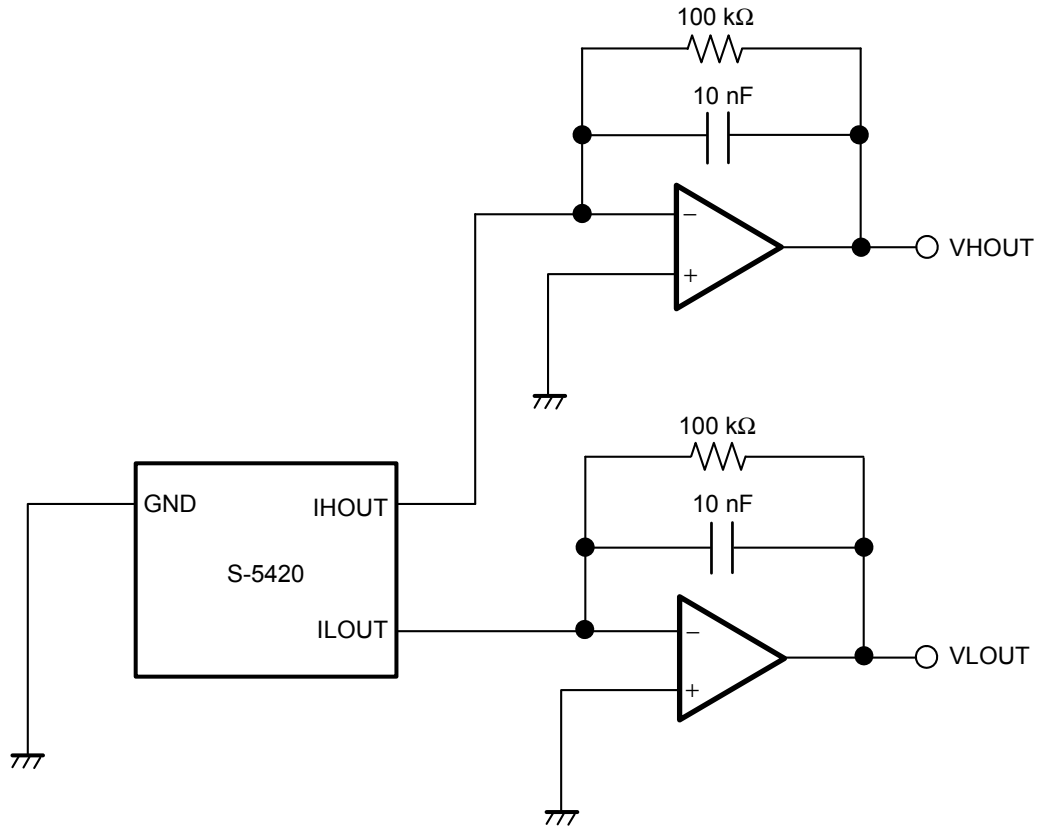

Figure 6

**Caution** The above connection diagram and constants will not guarantee successful operation. Perform thorough evaluation using the actual application to set the constants.

## ■ Precautions for Package

- The SON-6C package is compatible with a reflow soldering. Do not implement a hand soldering.
- The reflow profile in mounting evaluation of the SON-6C package is shown as below.

|                                 |  |
|---------------------------------|--|
| Preheating:                     | 180°C, 90 s                            |
| Heating:                        | 217°C to 260°C, 60 s to 80 s           |
| Peak heating:                   | 260°C, within 10 s                     |
| Temperature measurement point:  | Topside of the package (resin surface) |
| Number of maximum reflow cycle: | 1 time                                 |

- The optical characteristics may vary according to the reflow profile.
- The moisture sensitivity level of the SON-6C package is MSL 3. Do not use and store this package at high humidity. Packages tend to absorb moisture from the ambient atmosphere. If sudden heating is conducted in the process of a reflow soldering under moisture-absorbed condition, the moisture would vaporize and expand. It may cause interfacial delamination between the S-5420 chip and resin, package cracks, and other damages.
- The storage requirements after a moisture barrier bag is opened are as follows;

|                 |              |
|-----------------|--------------|
| Condition:      | ≤30°C/60% RH |
| Storage period: | 168 hours    |

If the above storage period exceeded, implement a reflow soldering after baking for 24 hours to 48 hours at Ta = 65°C.

## ■ Precautions

- Irradiating ultraviolet light for a long time may result in characteristic degradation such as sensitivity deterioration. Perform sufficient light-exposure evaluation before using the S-5420 under ultraviolet light irradiation environment.
- Do not apply an excessive electrostatic discharge to the S-5420.
- Large stress on the S-5420 may affect the sensitivity characteristics. Avoid large stress which is caused by the handling during or after mounting the IC on a board.
- ABLIC Inc. claims no responsibility for any disputes arising out of or in connection with any infringement by products including the S-5420 of patents owned by a third party.



■ Characteristics (Typical Data)

1. Sensitivity (High-sensitivity ultraviolet light PD)

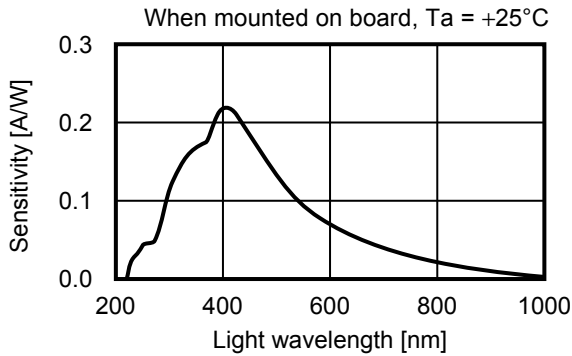

2. Sensitivity (Low-sensitivity ultraviolet light PD)

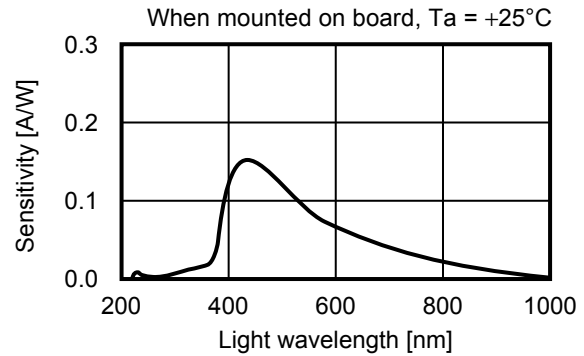

3. Differential sensitivity (High-sensitivity ultraviolet light PD – Low-sensitivity ultraviolet light PD)

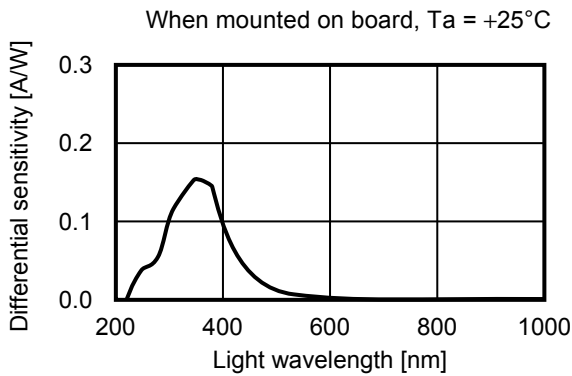

4. Sensitivity vs. Temperature

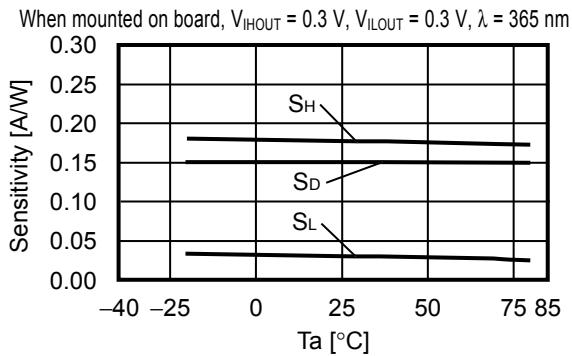

5. Dark current vs. Temperature

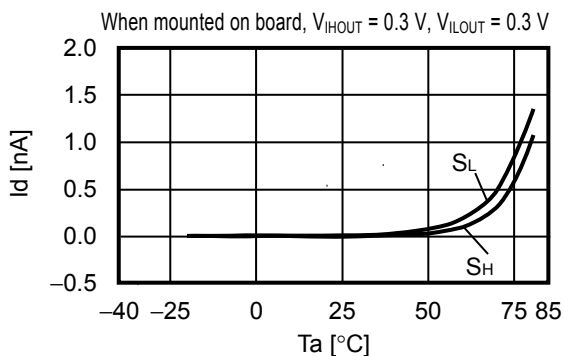

6. Dark current vs. Reverse voltage

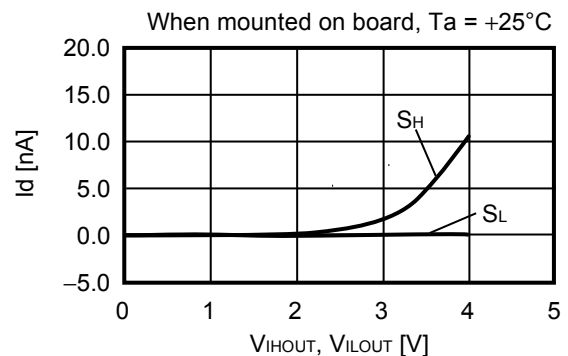

**7. Light exposure**

Test method: After irradiating the test light to a mount board, measuring the sensitivity.

Irradiation light at measurement: 300 nm, 365 nm Measurement timing: 0 hours, 500 hours, 1000 hours

**7.1 Light exposure 1**

Light source for test: Super Xenon Weather Meter (SX75)

(JIS B7754:1991 / Specified in light-exposure and light-and-water-exposure test apparatus (Xenon-arc lamp type))

Test conditions

Irradiance: 180 W/m<sup>2</sup> (300 nm to 400 nm) Irradiation time: 1000 hours

Inner filter: quartz Outer filter: #275

Black panel temperature: 63 ± 3°C Relative humidity: 50 ± 10%

**7.1.1 365 nm**

When mounted on board, V<sub>IHOUT</sub> = 0.3 V, V<sub>ILOUT</sub> = 0.3 V, Ta = +25°C

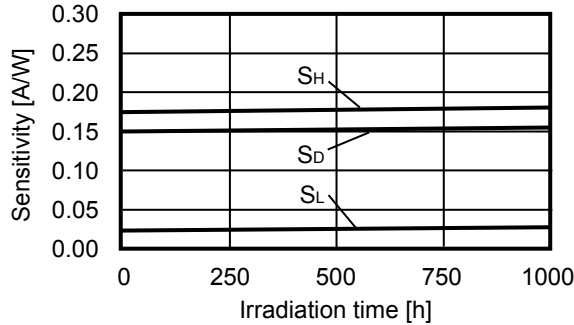

**7.1.2 300 nm**

When mounted on board, V<sub>IHOUT</sub> = 0.3 V, V<sub>ILOUT</sub> = 0.3 V, Ta = +25°C

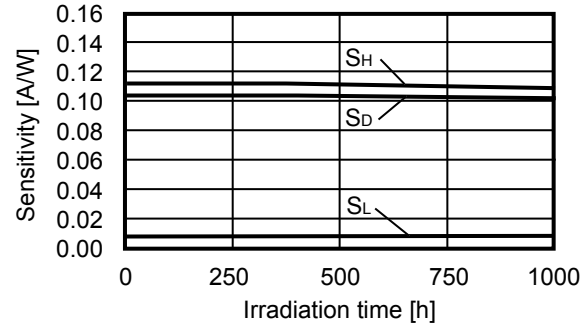

**7.2 Light exposure 2**

Light source for test: 365 nm LED (NSSU100CT)

Test conditions

Irradiance: 250 μW/cm<sup>2</sup> Irradiation time: 1000 hours

**7.2.1 365 nm**

When mounted on board, V<sub>IHOUT</sub> = 0.3 V, V<sub>ILOUT</sub> = 0.3 V, Ta = +25°C

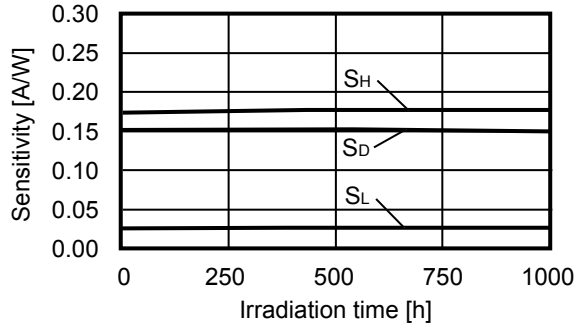

**7.2.2 300 nm**

When mounted on board, V<sub>IHOUT</sub> = 0.3 V, V<sub>ILOUT</sub> = 0.3 V, Ta = +25°C

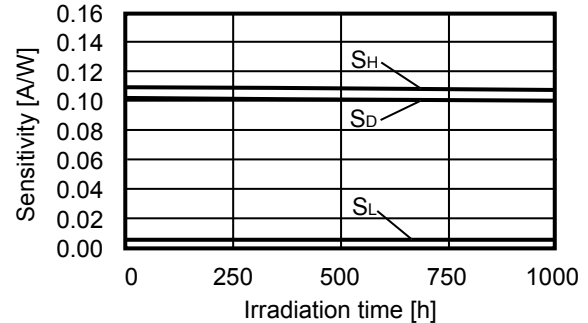

**7.3 Light exposure 3**

Light source for test: 300 nm LED (VPS1A1)

Test conditions

Irradiance: 250 μW/cm<sup>2</sup> Irradiation time: 1000 hours

**7.3.1 365 nm**

When mounted on board, V<sub>IHOUT</sub> = 0.3 V, V<sub>ILOUT</sub> = 0.3 V, Ta = +25°C

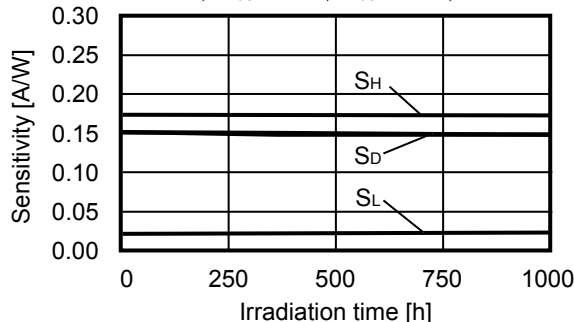

**7.3.2 300 nm**

When mounted on board, V<sub>IHOUT</sub> = 0.3 V, V<sub>ILOUT</sub> = 0.3 V, Ta = +25°C

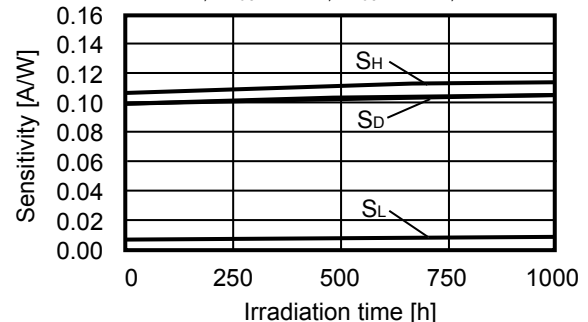

8. Directivity characteristics

8.1 PD<sub>H</sub>

When mounted on board, V<sub>IHOUT</sub> = 0.3 V, λ = 365 nm, T<sub>a</sub> = +25°C

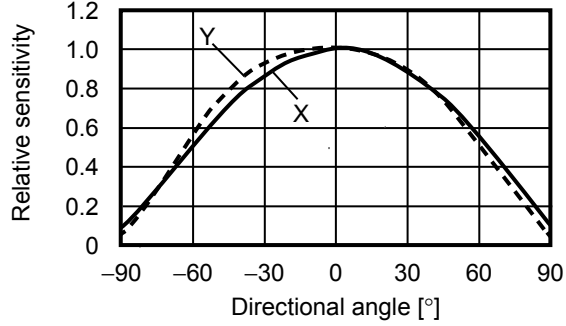

8.2 PD<sub>L</sub>

When mounted on board, V<sub>IHOUT</sub> = 0.3 V, λ = 365 nm, T<sub>a</sub> = +25°C

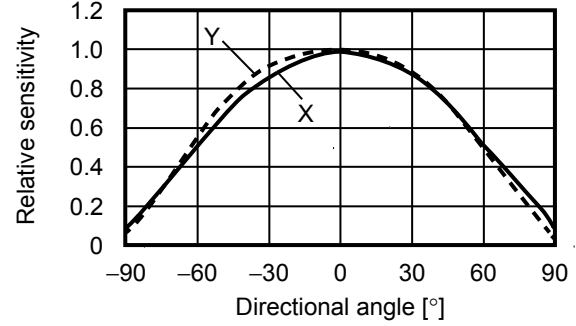

Remark X, Y: Rotation axes

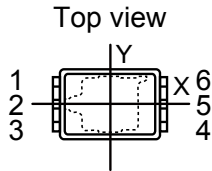

■ **Marking Specifications**

1. SON-6C

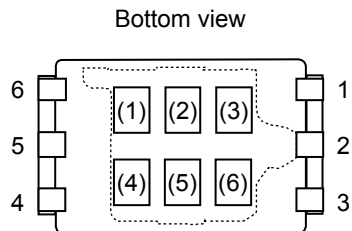

(1) to (3): Product code (refer to **Product name vs. Product code**)  
 (4) to (6): Lot number

**Product name vs. Product code**

| Product Name  | Product Code |     |     |
|---------------|--------------|-----|-----|
|               | (1)          | (2) | (3) |
| S-5420A-P6T2S | Z            | Y   | J   |

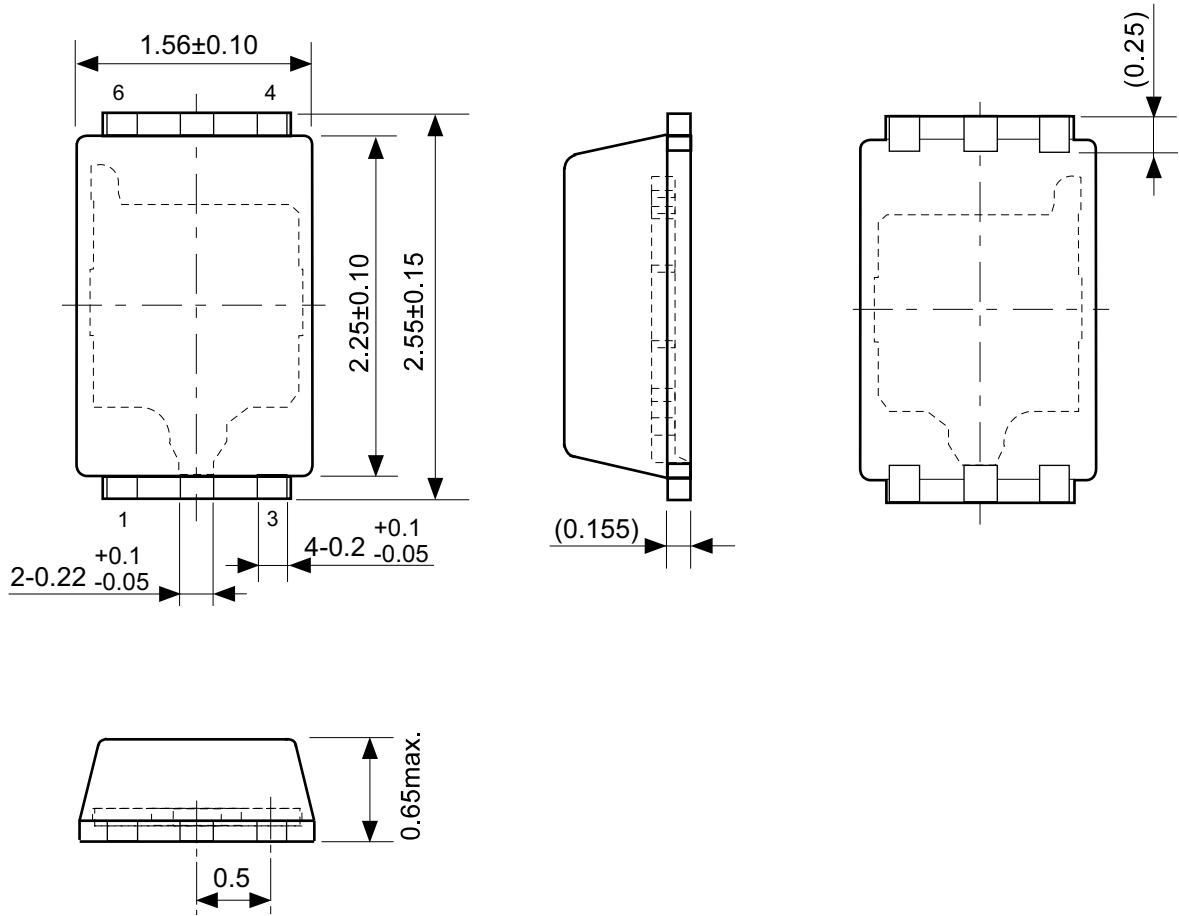

No. PZ006-A-P-SD-1.0

|                   |   |
|-------------------|---|
| TITLE             | SON-6C-A-PKG Dimensions   |
| No.               | PZ006-A-P-SD-1.0  |
| ANGLE             |  |
| UNIT              | mm  |
| <b>ABLIC Inc.</b> |   |

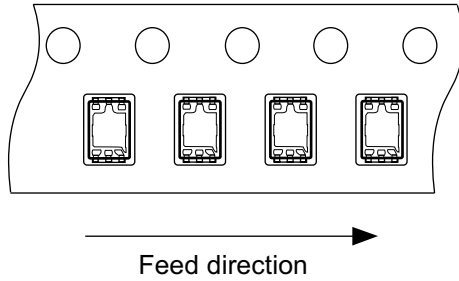
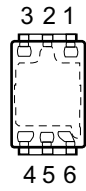
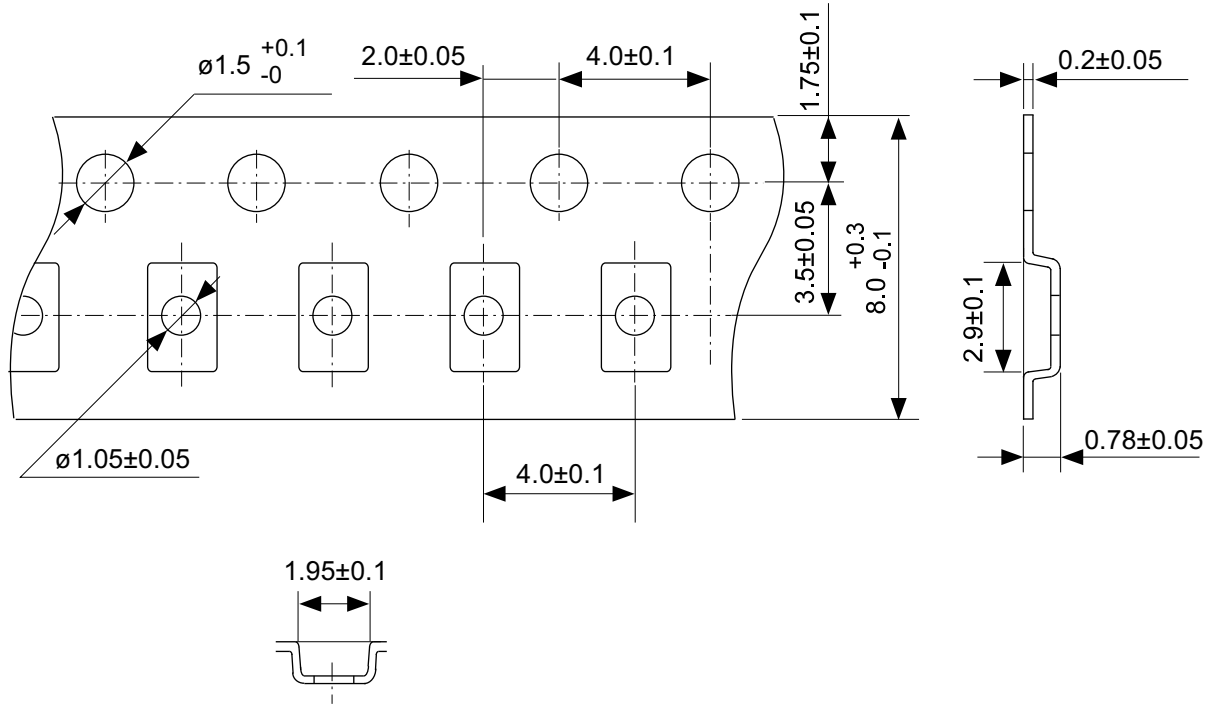

No. PZ006-A-C-SD-1.0

|                   |                       |
|-------------------|-----------------------|
| TITLE             | SON-6C-A-Carrier Tape |
| No.               | PZ006-A-C-SD-1.0      |
| ANGLE             |                       |
| UNIT              | mm                    |
| <b>ABLIC Inc.</b> |                       |

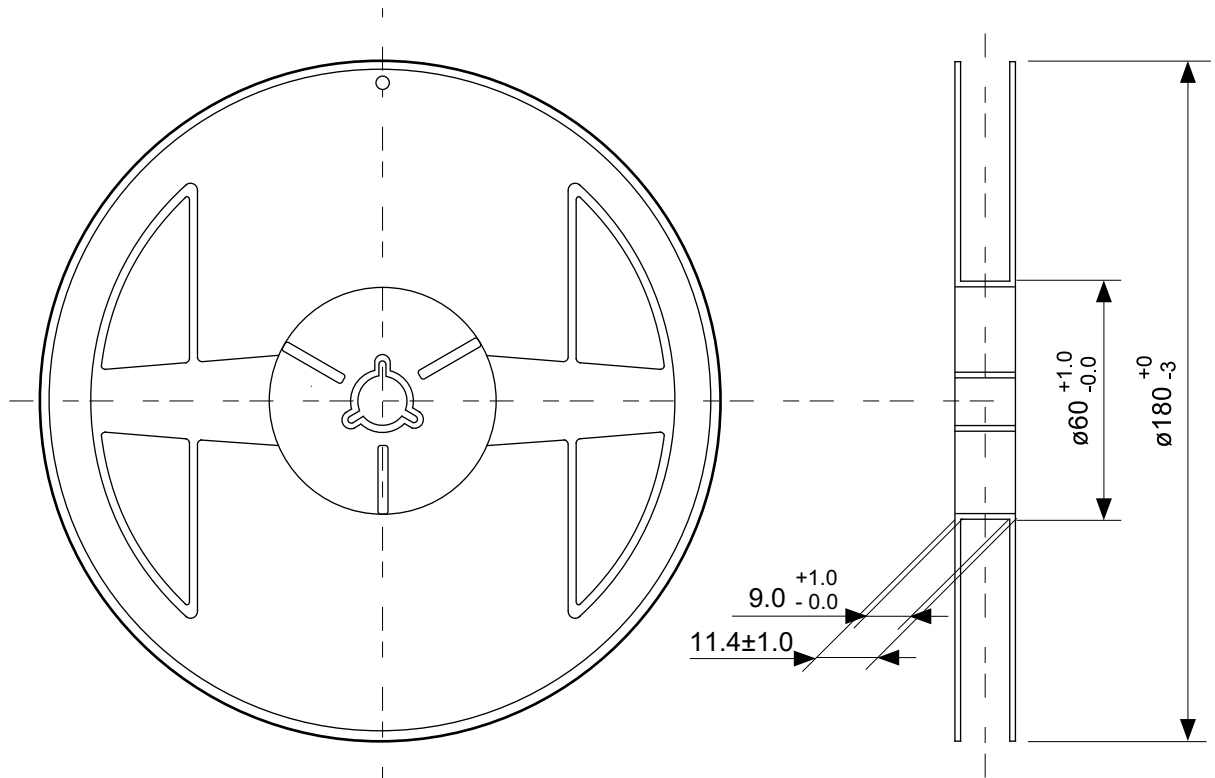

Enlarged drawing in the central part

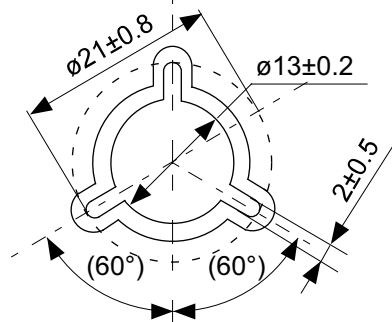

No. PZ006-A-R-SD-1.0

|                   |                  |     |      |
|-------------------|------------------|-----|------|
| TITLE             | SON-6C-A-Reel    |     |      |
| No.               | PZ006-A-R-SD-1.0 |     |      |
| ANGLE             |                  | QTY | 3000 |
| UNIT              | mm               |     |      |
|                   |                  |     |      |
| <b>ABLIC Inc.</b> |                  |     |      |

## Disclaimers (Handling Precautions)

1. All the information described herein (product data, specifications, figures, tables, programs, algorithms and application circuit examples, etc.) is current as of publishing date of this document and is subject to change without notice.
2. The circuit examples and the usages described herein are for reference only, and do not guarantee the success of any specific mass-production design.  
ABLIC Inc. is not responsible for damages caused by the reasons other than the products described herein (hereinafter "the products") or infringement of third-party intellectual property right and any other right due to the use of the information described herein.
3. ABLIC Inc. is not responsible for damages caused by the incorrect information described herein.
4. Be careful to use the products within their specified ranges. Pay special attention to the absolute maximum ratings, operation voltage range and electrical characteristics, etc.  
ABLIC Inc. is not responsible for damages caused by failures and / or accidents, etc. that occur due to the use of the products outside their specified ranges.
5. When using the products, confirm their applications, and the laws and regulations of the region or country where they are used and verify suitability, safety and other factors for the intended use.
6. When exporting the products, comply with the Foreign Exchange and Foreign Trade Act and all other export-related laws, and follow the required procedures.
7. The products must not be used or provided (exported) for the purposes of the development of weapons of mass destruction or military use. ABLIC Inc. is not responsible for any provision (export) to those whose purpose is to develop, manufacture, use or store nuclear, biological or chemical weapons, missiles, or other military use.
8. The products are not designed to be used as part of any device or equipment that may affect the human body, human life, or assets (such as medical equipment, disaster prevention systems, security systems, combustion control systems, infrastructure control systems, vehicle equipment, traffic systems, in-vehicle equipment, aviation equipment, aerospace equipment, and nuclear-related equipment), excluding when specified for in-vehicle use or other uses. Do not apply the products to the above listed devices and equipments without prior written permission by ABLIC Inc. Especially, the products cannot be used for life support devices, devices implanted in the human body and devices that directly affect human life, etc.  
Prior consultation with our sales office is required when considering the above uses.  
ABLIC Inc. is not responsible for damages caused by unauthorized or unspecified use of our products.
9. Semiconductor products may fail or malfunction with some probability.  
The user of the products should therefore take responsibility to give thorough consideration to safety design including redundancy, fire spread prevention measures, and malfunction prevention to prevent accidents causing injury or death, fires and social damage, etc. that may ensue from the products' failure or malfunction.  
The entire system must be sufficiently evaluated and applied on customer's own responsibility.
10. The products are not designed to be radiation-proof. The necessary radiation measures should be taken in the product design by the customer depending on the intended use.
11. The products do not affect human health under normal use. However, they contain chemical substances and heavy metals and should therefore not be put in the mouth. The fracture surfaces of wafers and chips may be sharp. Be careful when handling these with the bare hands to prevent injuries, etc.
12. When disposing of the products, comply with the laws and ordinances of the country or region where they are used.
13. The information described herein contains copyright information and know-how of ABLIC Inc.  
The information described herein does not convey any license under any intellectual property rights or any other rights belonging to ABLIC Inc. or a third party. Reproduction or copying of the information from this document or any part of this document described herein for the purpose of disclosing it to a third-party without the express permission of ABLIC Inc. is strictly prohibited.
14. For more details on the information described herein, contact our sales office.

2.2-2018.06