

## TEMPERATURE SWITCH IC (THERMOSTAT IC)

[www.sii-ic.com](http://www.sii-ic.com)

© Seiko Instruments Inc., 2007-2015

Rev.2.2\_00

The S-5841 Series is a temperature switch IC (thermostat IC) which detects the temperature with a temperature accuracy of  $\pm 2.5^{\circ}\text{C}$ . The output inverts when temperature reaches the detection temperature. The S-5841 Series restores the output voltage when the temperature drops to the level of release temperature.

The S-5841 Series operates at the lower power supply voltage of 2.2 V and its current consumption is 10  $\mu\text{A}$  typ. due to CMOS configuration.

A temperature sensor with the negative temperature coefficient, a reference voltage generation circuit, a comparator and a delay circuit are integrated on one chip, and enclosed into the packages SOT-23-5 and SNT-6A.

### ■ Features

- Detection temperature:  $T_{\text{DET}} = +40^{\circ}\text{C}$  to  $+100^{\circ}\text{C}$ ,  $+1^{\circ}\text{C}$  step, detection accuracy:  $\pm 2.5^{\circ}\text{C}$
- Low voltage operation:  $V_{\text{DD}} = 2.2\text{ V min.}$   
(Detection temperature =  $+55^{\circ}\text{C}$  to  $+100^{\circ}\text{C}$ ,  $T_{\text{a}} = -40^{\circ}\text{C}$  to  $+100^{\circ}\text{C}$ )
- Low current consumption:  $I_{\text{DD}} = 10\ \mu\text{A typ.}$  ( $T_{\text{a}} = +25^{\circ}\text{C}$ )
- Hysteresis temperature can be switched in  $0^{\circ}\text{C}$ ,  $2^{\circ}\text{C}$ ,  $4^{\circ}\text{C}$  and  $10^{\circ}\text{C}$ .
- Selectable output logic in active "H" or "L"
- Selectable output form in CMOS or Nch open drain
- Operation temperature range:  $T_{\text{a}} = -40^{\circ}\text{C}$  to  $+125^{\circ}\text{C}$
- Lead-free, Sn 100%, halogen-free<sup>\*1</sup>

\*1. Refer to "■ Product Name Structure" for details.

### ■ Applications

- Fan control
- Air conditioning system
- Various electronic devices

### ■ Packages

- SOT-23-5
- SNT-6A

■ Block Diagrams

1. CMOS output product

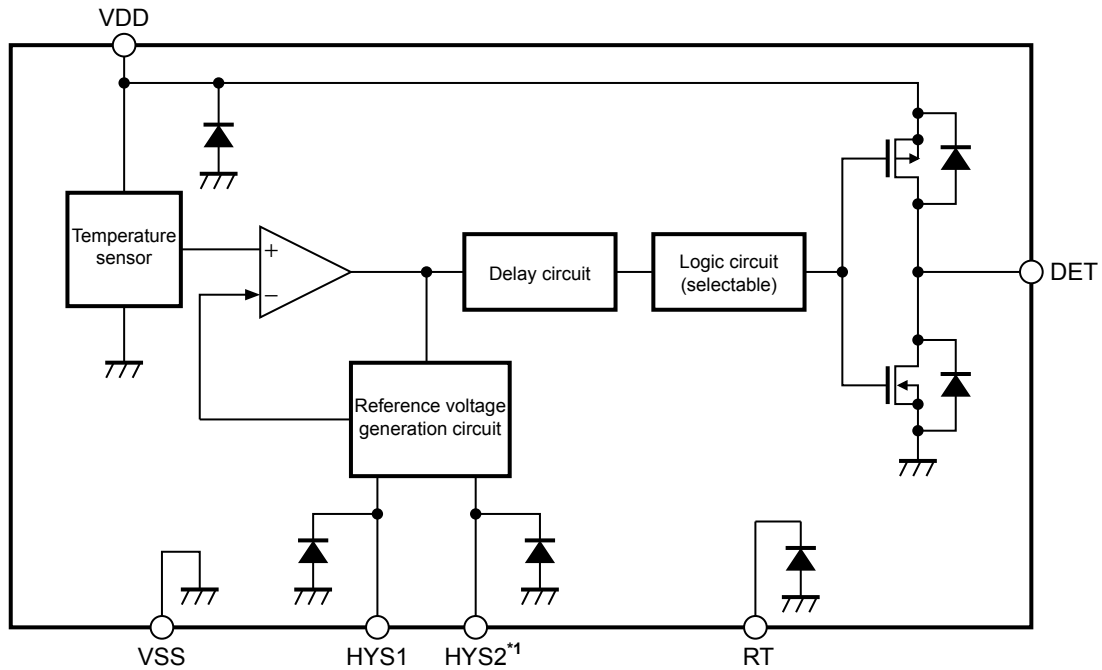

\*1. The HYS2 pin is not equipped for SOT-23-5.

Figure 1

2. Nch open drain output product

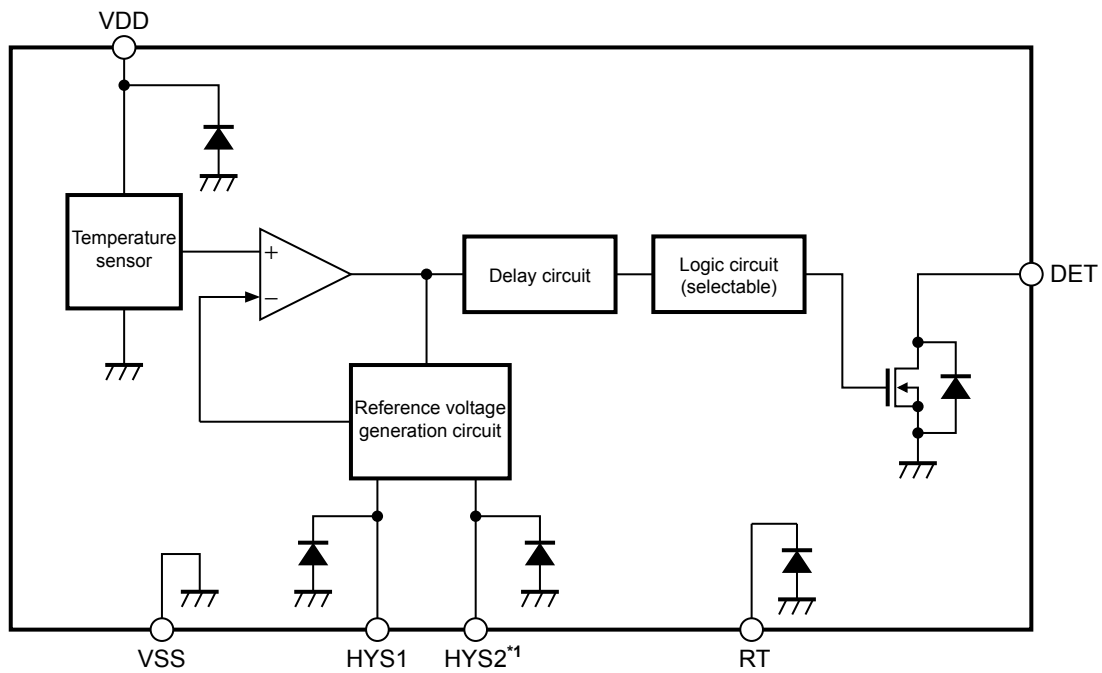

\*1. The HYS2 pin is not equipped for SOT-23-5.

Figure 2

■ Product Name Structure

Users are able to select the option for hysteresis temperature, detection temperature, output form and logic, package for the S-5841 Series.

1. Product name

1.1 SOT-23-5

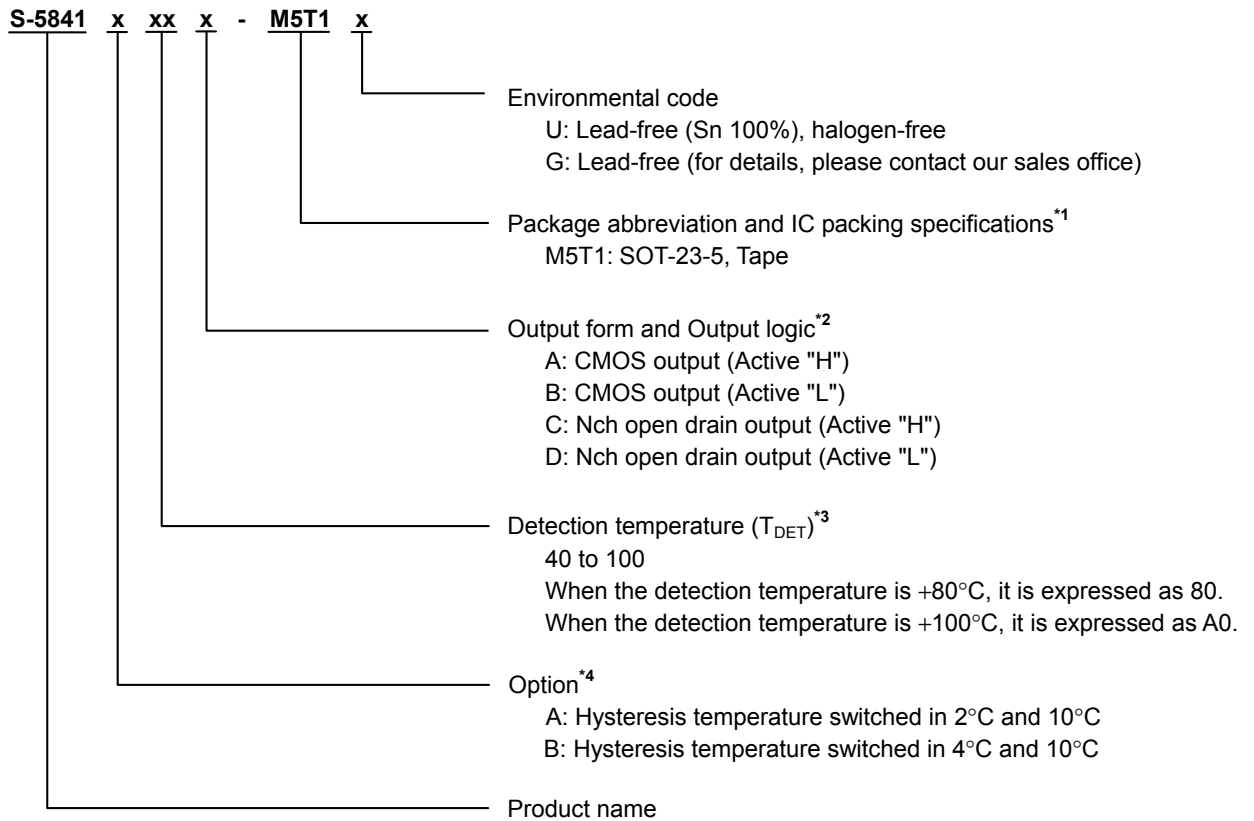

- \*1. Refer to the tape drawing.
- \*2. The DET pin output can be selected the output logic in active "H" or "L".  
The DET pin output can be selected the output form in CMOS or Nch open drain.
- \*3. The detection temperature (T<sub>DET</sub>) can be set in the range of +40°C to +100°C at 1°C step.
- \*4. The hysteresis temperature is set by the HYS1 pin. By option, the hysteresis temperature of the product is selectable in 2°C and 10°C / 4°C and 10°C.

**1.2 SNT-6A**

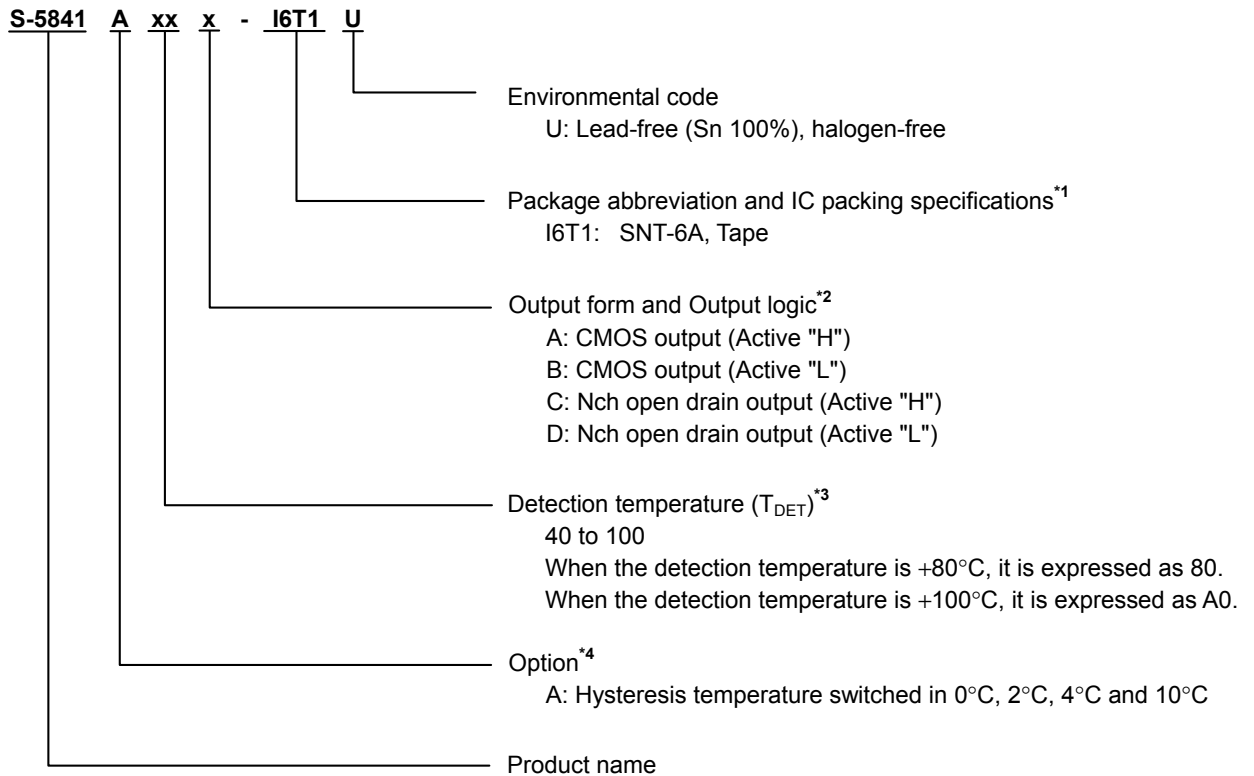

- \*1. Refer to the tape drawing.
- \*2. The DET pin output can be selected the output logic in active "H" or "L".  
The DET pin output can be selected the output form in CMOS or Nch open drain.
- \*3. The detection temperature (T<sub>DET</sub>) can be set in the range of +40°C to +100°C at 1°C step.
- \*4. The hysteresis temperature can be switched in 0°C, 2°C, 4°C, 10°C, and is set by the HYS1 pin and the HYS2 pin.

**2. Packages**

**Table 1 Package Drawing Codes**

Package Name	Dimension	Tape	Reel	Land
SOT-23-5	MP005-A-P-SD	MP005-A-C-SD	MP005-A-R-SD	—
SNT-6A	PG006-A-P-SD	PG006-A-C-SD	PG006-A-R-SD	PG006-A-L-SD

**3. Product name list**

**3.1 SOT-23-5**

**Table 2**

Product Name	Detection Temperature (T <sub>DET</sub> )	DET Pin Output Form	DET Pin Output Logic	Hysteresis Temperature (T <sub>HYS</sub> )
S-5841A55D-M5T1x	+55°C	Nch open drain	Active "L"	2°C, 10°C
S-5841A65D-M5T1x	+65°C	Nch open drain	Active "L"	2°C, 10°C
S-5841A75D-M5T1x	+75°C	Nch open drain	Active "L"	2°C, 10°C
S-5841A85D-M5T1x	+85°C	Nch open drain	Active "L"	2°C, 10°C
S-5841A95D-M5T1x	+95°C	Nch open drain	Active "L"	2°C, 10°C

**Remark 1.** Please contact our sales office for products other than those specified above.

2. x: G or U

3. Please select products of environmental code = U for Sn 100%, halogen-free products.

**3.2 SNT-6A**

**Table 3**

Product Name	Detection Temperature (T <sub>DET</sub> )	DET Pin Output Form	DET Pin Output Logic	Hysteresis Temperature (T <sub>HYS</sub> )
S-5841A70A-I6T1U	+70°C	CMOS	Active "H"	0°C, 2°C, 4°C, 10°C
S-5841A80A-I6T1U	+80°C	CMOS	Active "H"	0°C, 2°C, 4°C, 10°C
S-5841A90A-I6T1U	+90°C	CMOS	Active "H"	0°C, 2°C, 4°C, 10°C
S-5841A50D-I6T1U	+50°C	Nch open drain	Active "L"	0°C, 2°C, 4°C, 10°C

**Remark** Please contact our sales office for products other than those specified above.

■ Pin Configurations

1. SOT-23-5

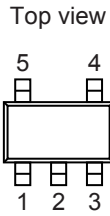

Figure 3

Table 4

Pin No.	Symbol	Description
1	HYS1 <sup>*1</sup>	Hysteresis pin 1
2	VSS	GND pin
3	RT <sup>*2</sup>	Test pin
4	VDD	Power supply pin
5	DET	Output pin

\*1. Fix the HYS1 pin as VDD pin or VSS pin in use.

\*2. Set the RT pin open in use.

2. SNT-6A

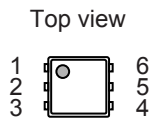

Figure 4

Table 5

Pin No.	Symbol	Description
1	RT <sup>*1</sup>	Test pin
2	VSS	GND pin
3	HYS1 <sup>*2</sup>	Hysteresis pin 1
4	DET	Output pin
5	HYS2 <sup>*2</sup>	Hysteresis pin 2
6	VDD	Power supply pin

\*1. Set the RT pin open in use.

\*2. Fix the HYS1 pin and the HYS2 pin as VDD pin or VSS pin in use.

## ■ Absolute Maximum Ratings

Table 6

(Ta = +25°C unless otherwise specified)

Item		Symbol	Absolute Maximum Rating	Unit
Power supply voltage (V <sub>SS</sub> = 0 V)		V <sub>DD</sub>	V <sub>SS</sub> + 12	V
Pin voltage		V <sub>RT</sub> , V <sub>HYS1</sub> , V <sub>HYS2</sub>	V <sub>SS</sub> - 0.3 to V <sub>DD</sub> + 0.3	V
Output voltage	CMOS output product	V <sub>DET</sub>	V <sub>SS</sub> - 0.3 to V <sub>DD</sub> + 0.3	V
	Nch open drain product		V <sub>SS</sub> - 0.3 to V <sub>SS</sub> + 12.0	V
Power dissipation	SOT-23-5	P <sub>D</sub>	600 <sup>*1</sup>	mW
	SNT-6A		400 <sup>*1</sup>	mW
Operating ambient temperature		T <sub>opr</sub>	-40 to +125	°C
Storage temperature		T <sub>stg</sub>	-55 to +150	°C

\*1. When mounted on board

[Mounted board]

- (1) Board size : 114.3 mm × 76.2 mm × t1.6 mm
- (2) Board name : JEDEC STANDARD51-7

**Caution** The absolute maximum ratings are rated values exceeding which the product could suffer physical damage. These values must therefore not be exceeded under any conditions.

■ DC Electrical Characteristics

1. CMOS output product

1.1 SOT-23-5

Table 7

(Ta = +25°C, unless otherwise specified)

Item	Symbol	Condition		Min.	Typ.	Max.	Unit	Test circuit
Power supply voltage*1	V <sub>DD</sub>	T <sub>DET</sub> = +55°C to +100°C		2.2	–	10.0	V	1
		T <sub>DET</sub> = +40°C to +54°C		2.6	–	10.0	V	1
Detection temperature	+T <sub>D</sub>	–		T <sub>DET</sub> – 2.5	T <sub>DET</sub>	T <sub>DET</sub> + 2.5	°C	1
Hysteresis of detection temperature*2	T <sub>HYS</sub>	Hysteresis option	HYS1	–	–	–	–	–
		A	"H"	–	2	–	°C	1
			"L"	–	10	–	°C	1
		B	"H"	–	4	–	°C	1
"L"	–		10	–	°C	1		
Output current	I <sub>DETH</sub>	V <sub>DD</sub> = 3.0 V, apply to DET pin	V <sub>DET</sub> = 2.2 V	2	9.4	–	mA	2
	I <sub>DETL</sub>		V <sub>DET</sub> = 0.4 V	0.5	2.3	–	mA	2
Current consumption during operation	I <sub>DD</sub>	V <sub>DD</sub> = 3.0 V		–	10	20	μA	1
HYS1 pin input voltage "H"	V <sub>IH1</sub>	–		0.8 × V <sub>DD</sub>	–	–	V	3
HYS1 pin input voltage "L"	V <sub>IL1</sub>	–		–	–	0.2 × V <sub>DD</sub>	V	3
HYS1 pin input current "H"	I <sub>IH1</sub>	V <sub>DD</sub> = 3.0 V, V <sub>HYS1</sub> = 3.0 V		–0.1	–	0.1	μA	3
HYS1 pin input current "L"	I <sub>IL1</sub>	V <sub>DD</sub> = 3.0 V, V <sub>HYS1</sub> = 0 V		–0.1	–	0.1	μA	3

\*1. The minimum operation voltages are as follows under the operation ambient temperature over +100°C.  
V<sub>DD</sub> = 2.3 V min. (Detection temperature = +55°C to +100°C)  
V<sub>DD</sub> = 2.7 V min. (Detection temperature = +40°C to +54°C)

\*2. The hysteresis temperature can be set by the HYS1 pin.  
These two types are selectable by option.  
Hysteresis option A: 2°C of hysteresis temperature during HYS1 = "H",  
10°C of hysteresis temperature during HYS1 = "L"  
Hysteresis option B: 4°C of hysteresis temperature during HYS1 = "H",  
10°C of hysteresis temperature during HYS1 = "L"

[Fahrenheit ⇔ Celsius Conversion equation]

$$^{\circ}\text{C} = (^{\circ}\text{F} - 32) \times 5 / 9$$

$$^{\circ}\text{F} = 32 + ^{\circ}\text{C} \times 9 / 5$$



**1.2 SNT-6A**

**Table 8**

(Ta = +25°C, unless otherwise specified)

Item	Symbol	Condition	Min.	Typ.	Max.	Unit	Test circuit	
Power supply voltage*1	V <sub>DD</sub>	T <sub>DET</sub> = +55°C to +100°C	2.2	–	10.0	V	1	
		T <sub>DET</sub> = +40°C to +54°C	2.6	–	10.0	V	1	
Detection temperature	+T <sub>D</sub>	–	T <sub>DET</sub> – 2.5	T <sub>DET</sub>	T <sub>DET</sub> + 2.5	°C	1	
Hysteresis of detection temperature*2	T <sub>HYS</sub>	HYS1	HYS2	–	–	–	–	
		"H"	"H"	–	2	–	°C	
		"H"	"L"	–	4	–	°C	
		"L"	"H"	–	10	–	°C	
		"L"	"L"	–	0	–	°C	
Output current	I <sub>DETH</sub>	V <sub>DD</sub> = 3.0 V, apply to DET pin	V <sub>DET</sub> = 2.2 V	2	9.4	–	mA	2
	I <sub>DETL</sub>		V <sub>DET</sub> = 0.4 V	0.5	2.3	–	mA	2
Current consumption during operation	I <sub>DD</sub>	V <sub>DD</sub> = 3.0 V	–	10	20	μA	1	
HYS1 pin input voltage "H"	V <sub>IH1</sub>	–	0.8 × V <sub>DD</sub>	–	–	V	3	
HYS1 pin input voltage "L"	V <sub>IL1</sub>	–	–	–	0.2 × V <sub>DD</sub>	V	3	
HYS1 pin input current "H"	I <sub>IH1</sub>	V <sub>DD</sub> = 3.0 V, V <sub>HYS1</sub> = 3.0 V	–0.1	–	0.1	μA	3	
HYS1 pin input current "L"	I <sub>IL1</sub>	V <sub>DD</sub> = 3.0 V, V <sub>HYS1</sub> = 0 V	–0.1	–	0.1	μA	3	
HYS2 pin input voltage "H"	V <sub>IH2</sub>	–	0.8 × V <sub>DD</sub>	–	–	V	3	
HYS2 pin input voltage "L"	V <sub>IL2</sub>	–	–	–	0.2 × V <sub>DD</sub>	V	3	
HYS2 pin input current "H"	I <sub>IH2</sub>	V <sub>DD</sub> = 3.0 V, V <sub>HYS2</sub> = 3.0 V	–0.1	–	0.1	μA	3	
HYS2 pin input current "L"	I <sub>IL2</sub>	V <sub>DD</sub> = 3.0 V, V <sub>HYS2</sub> = 0 V	–0.1	–	0.1	μA	3	

\*1. The minimum operation voltages are as follows under the operation ambient temperature over +100°C.

V<sub>DD</sub> = 2.3 V min. (Detection temperature = +55°C to +100°C)

V<sub>DD</sub> = 2.7 V min. (Detection temperature = +40°C to +54°C)

\*2. The hysteresis temperature can be switched in 0°C, 2°C, 4°C, 10°C, and is set by the HYS1 pin and HYS2 pin.

**[Fahrenheit ⇔ Celsius Conversion equation]**

$$^{\circ}\text{C} = (^{\circ}\text{F} - 32) \times 5 / 9$$

$$^{\circ}\text{F} = 32 + ^{\circ}\text{C} \times 9 / 5$$

**2. Nch open drain output**

**2.1 SOT-23-5**

**Table 9**

(Ta = +25°C, unless otherwise specified)

Item	Symbol	Condition	Min.	Typ.	Max.	Unit	Test circuit	
Power supply voltage*1	V <sub>DD</sub>	T <sub>DET</sub> = +55°C to +100°C	2.2	–	10.0	V	1	
		T <sub>DET</sub> = +40°C to +54°C	2.6	–	10.0	V	1	
Detection temperature	+T <sub>D</sub>	–	T <sub>DET</sub> – 2.5	T <sub>DET</sub>	T <sub>DET</sub> + 2.5	°C	1	
Hysteresis of detection temperature*2	T <sub>HYS</sub>	Hysteresis option	HYS1		–	–	–	
		A	"H"	–	2	–	°C	1
			"L"	–	10	–	°C	1
		B	"H"	–	4	–	°C	1
"L"	–		10	–	°C	1		
Output current	I <sub>DETL</sub>	V <sub>DET</sub> = 0.4 V, V <sub>DD</sub> = 3.0 V	0.5	2.3	–	mA	2	
Leakage current	I <sub>LEAK</sub>	V <sub>DET</sub> = 10.0 V, V <sub>DD</sub> = 3.0 V	–	–	100	nA	2	
Current consumption during operation	I <sub>DD</sub>	V <sub>DD</sub> = 3.0 V	–	10	20	μA	1	
HYS1 pin input voltage "H"	V <sub>IH1</sub>	–	0.8 × V <sub>DD</sub>	–	–	V	3	
HYS1 pin input voltage "L"	V <sub>IL1</sub>	–	–	–	0.2 × V <sub>DD</sub>	V	3	
HYS1 pin input current "H"	I <sub>IH1</sub>	V <sub>DD</sub> = 3.0 V, V <sub>HYS1</sub> = 3.0 V	–0.1	–	0.1	μA	3	
HYS1 pin input current "L"	I <sub>IL1</sub>	V <sub>DD</sub> = 3.0 V, V <sub>HYS1</sub> = 0 V	–0.1	–	0.1	μA	3	

\*1. The minimum operation voltages are as follows under the operation ambient temperature over +100°C.

V<sub>DD</sub> = 2.3 V min. (Detection temperature = +55°C to +100°C)

V<sub>DD</sub> = 2.7 V min. (Detection temperature = +40°C to +54°C)

\*2. The hysteresis temperature can be set by the HYS1 pin.

These two types are selectable by option.

Hysteresis option A: 2°C of hysteresis temperature during HYS1 = "H",  
 10°C of hysteresis temperature during HYS1 = "L"

Hysteresis option B: 4°C of hysteresis temperature during HYS1 = "H",  
 10°C of hysteresis temperature during HYS1 = "L"

**[Fahrenheit ↔ Celsius Conversion equation]**

$$^{\circ}\text{C} = (^{\circ}\text{F} - 32) \times 5 / 9$$

$$^{\circ}\text{F} = 32 + ^{\circ}\text{C} \times 9 / 5$$

**2.2 SNT-6A**

**Table 10**

(Ta = +25°C, unless otherwise specified)

Item	Symbol	Condition	Min.	Typ.	Max.	Unit	Test circuit
Power supply voltage*1	V <sub>DD</sub>	T <sub>DET</sub> = +55°C to +100°C	2.2	–	10.0	V	1
		T <sub>DET</sub> = +40°C to +54°C	2.6	–	10.0	V	1
Detection temperature	+T <sub>D</sub>	–	T <sub>DET</sub> – 2.5	T <sub>DET</sub>	T <sub>DET</sub> + 2.5	°C	1
Hysteresis of detection temperature*2	T <sub>HYS</sub>	HYS1	HYS2	–	–	–	–
		"H"	"H"	–	2	–	°C
		"H"	"L"	–	4	–	°C
		"L"	"H"	–	10	–	°C
		"L"	"L"	–	0	–	°C
Output current	I <sub>DETL</sub>	V <sub>DET</sub> = 0.4 V, V <sub>DD</sub> = 3.0 V	0.5	2.3	–	mA	2
Leakage current	I <sub>LEAK</sub>	V <sub>DET</sub> = 10.0 V, V <sub>DD</sub> = 3.0 V	–	–	100	nA	2
Current consumption during operation	I <sub>DD</sub>	V <sub>DD</sub> = 3.0 V	–	10	20	μA	1
HYS1 pin input voltage "H"	V <sub>IH1</sub>	–	0.8 × V <sub>DD</sub>	–	–	V	3
HYS1 pin input voltage "L"	V <sub>IL1</sub>	–	–	–	0.2 × V <sub>DD</sub>	V	3
HYS1 pin input current "H"	I <sub>IH1</sub>	V <sub>DD</sub> = 3.0 V, V <sub>HYS1</sub> = 3.0 V	–0.1	–	0.1	μA	3
HYS1 pin input current "L"	I <sub>IL1</sub>	V <sub>DD</sub> = 3.0 V, V <sub>HYS1</sub> = 0 V	–0.1	–	0.1	μA	3
HYS2 pin input voltage "H"	V <sub>IH2</sub>	–	0.8 × V <sub>DD</sub>	–	–	V	3
HYS2 pin input voltage "L"	V <sub>IL2</sub>	–	–	–	0.2 × V <sub>DD</sub>	V	3
HYS2 pin input current "H"	I <sub>IH2</sub>	V <sub>DD</sub> = 3.0 V, V <sub>HYS2</sub> = 3.0 V	–0.1	–	0.1	μA	3
HYS2 pin input current "L"	I <sub>IL2</sub>	V <sub>DD</sub> = 3.0 V, V <sub>HYS2</sub> = 0 V	–0.1	–	0.1	μA	3

\*1. The minimum operation voltages are as follows under the operation ambient temperature over +100°C.

V<sub>DD</sub> = 2.3 V min. (Detection temperature = +55°C to +100°C)

V<sub>DD</sub> = 2.7 V min. (Detection temperature = +40°C to +54°C)

\*2. The hysteresis temperature can be switched in 0°C, 2°C, 4°C, 10°C, and is set by the HYS1 pin and HYS2 pin.

**[Fahrenheit ↔ Celsius Conversion equation]**

°C = (°F – 32) × 5 / 9

°F = 32 + °C × 9 / 5

**■ AC Electrical Characteristics**

**Table 11**

Item	Symbol	Condition	Min.	Typ.	Max.	Unit	Test circuit
Noise suppression time	t <sub>delay</sub>	V <sub>DD</sub> = 3.0 V, Ta = detection temperature	–	380	–	μs	–

■ Test Circuits

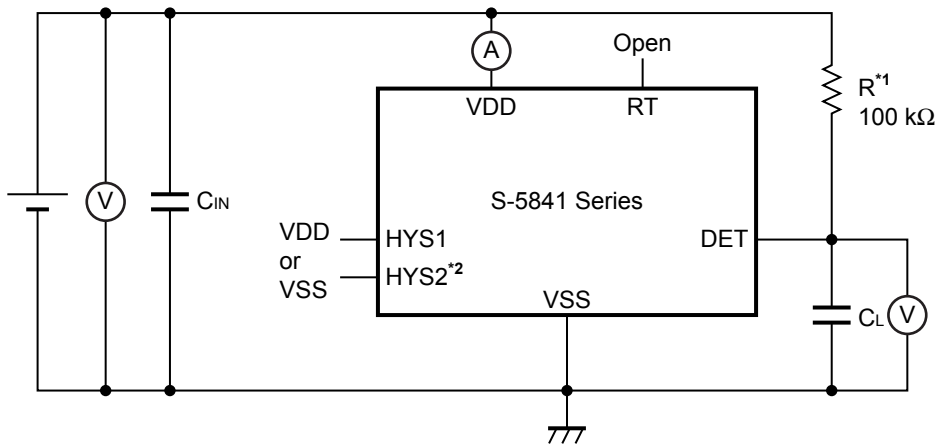

- \*1. Resistor (R) is unnecessary for the CMOS output product.
- \*2. The HYS2 pin is not equipped for SOT-23-5.

Figure 5 Test Circuit 1

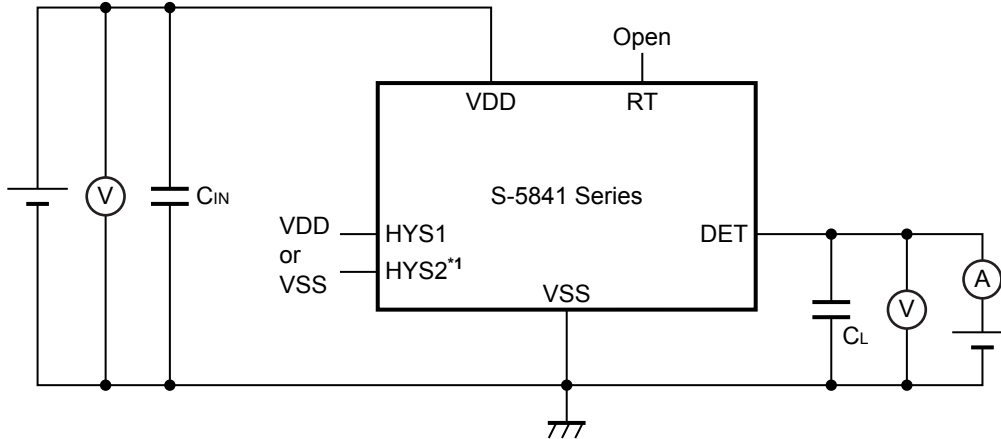

- \*1. The HYS2 pin is not equipped for SOT-23-5.

Figure 6 Test Circuit 2

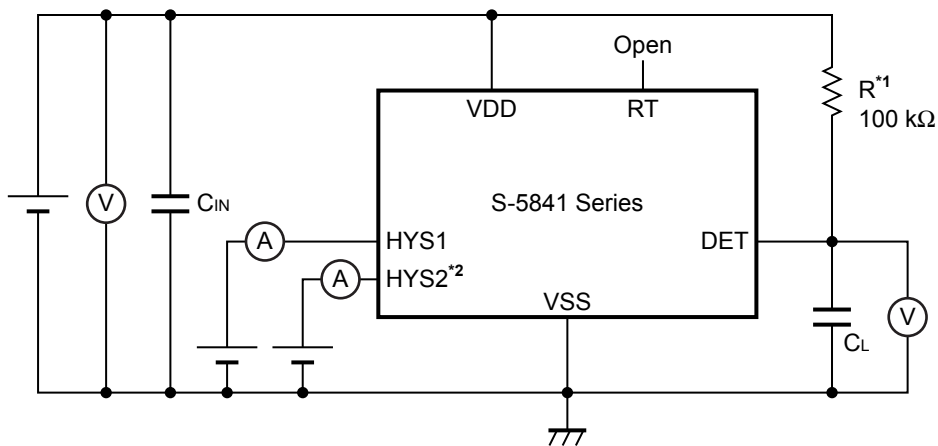

- \*1. Resistor (R) is unnecessary for the CMOS output product.
- \*2. The HYS2 pin is not equipped for SOT-23-5.

Figure 7 Test Circuit 3

■ **Operation**

**1. Basic operation**

The S-5841 Series is a temperature switch IC (thermostat IC) which detects a certain temperature and sends a signal to an external device. Various combinations of the parameters such as the detection temperature, output form and output logic can be selected.

Following is about the operation when the DET pin output logic is active "H".

After applying the power supply, the S-5841 Series starts to detect the temperature. If it is lower than the detection temperature ( $+T_D$ ), the DET pin output keeps "L". The temperature rises and exceeds the detection temperature, the DET pin is set to "H".

After the detection, the temperature drops and reaches the release temperature ( $+T_D - T_{HYS}$ ), the DET pin returns to "L".

**Figure 8** is the timing chart.

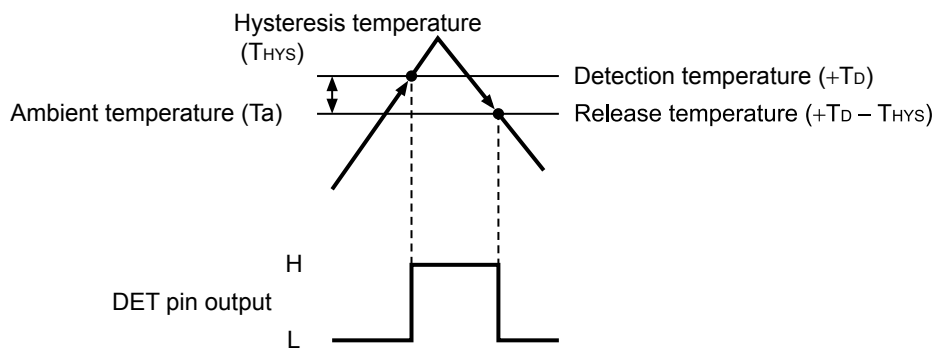

**Figure 8 Operation when DET Pin Output Logic is Active "H"**

**2. Hysteresis setting**

**2.1 SOT-23-5**

The hysteresis temperature can be set by the HYS1 pin. By option, the hysteresis temperature of the product is selectable in 2°C and 10°C / 4°C and 10°C.

**Table 12 Hysteresis Option A**

Setting Pin	Hysteresis Temperature
HYS1	
"H"	2°C
"L"	10°C

**Table 13 Hysteresis Option B**

Setting Pin	Hysteresis Temperature
HYS1	
"H"	4°C
"L"	10°C

**2.2 SNT-6A**

The hysteresis temperature can be switched in 0°C, 2°C, 4°C, 10°C, and is set by the HYS1 pin and HYS2 pin.

**Table 14 Hysteresis Option A**

Setting Pin		Hysteresis Temperature
HYS1	HYS2	
"H"	"H"	2°C
"H"	"L"	4°C
"L"	"H"	10°C
"L"	"L"	0°C

**3. Delay circuit**

The S-5841 Series sets the noise suppression time ( $t_{\text{delay}}$ ) via the delay circuit. By this, the S-5841 Series prevents false detection operations of the DET pin output.

The followings are about the operation when the DET pin output logic is active "H".

**3.1 The temperature is the detection temperature or less**

The output from a comparator is "H", and the DET pin is "L". Due to noise or others, the output from a comparator is inverted to "L" once; however, the DET pin keeps "L" if this status is  $t_{\text{delay}}$  or shorter.

**3.2 The temperature exceeds the detection temperature**

The output from a comparator gets "L". And the DET pin gets "H" after the period has passed  $t_{\text{delay}}$  or longer.

■ Standard Circuit

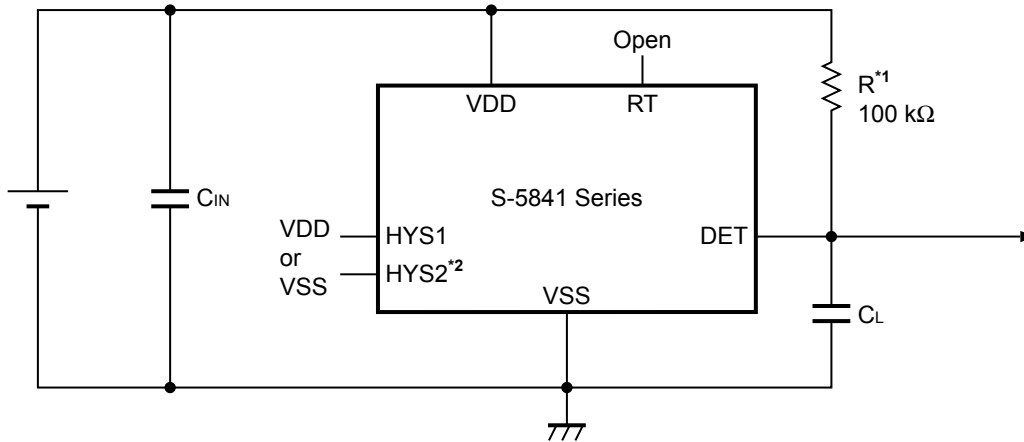

- \*1. Resistor (R) is unnecessary for the CMOS output product.
- \*2. The HYS2 pin is not equipped with SOT-23-5.

Figure 9

**Caution** The above connection diagram will not guarantee successful operation. Perform thorough evaluation using actual application to set the constant.

■ Precautions

- Set a capacitor ( $C_{IN}$ ) of 0.1  $\mu\text{F}$  or more between the VDD and VSS pin for stabilization.
- Set a capacitor ( $C_L$ ) of about 1  $\mu\text{F}$  for the DET pin to prevent malfunction caused by the noise when the power supply is applied.
- The S-5841 Series may oscillate by setting a capacitor to the RT pin. Set the RT pin open in use.
- If the RT pin is short-circuited to VSS, the DET pin becomes active in the S-5841 Series.
- Fix the HYS1 pin and the HYS2 pin VDD or VSS in use.
- Do not apply an electrostatic discharge to this IC that exceeds the performance ratings of the built-in electrostatic protection circuit.
- SII claims no responsibility for any disputes arising out of or in connection with any infringement by products, including this IC, of patents owned by a third party.

■ Characteristics (Typical Data)

1. Current consumption vs. Power supply voltage characteristics

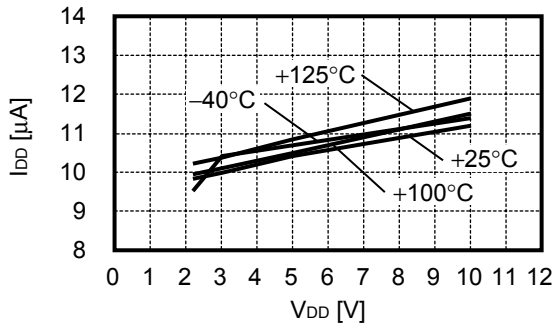

2. DET pin current "H" vs. Power supply voltage characteristics (CMOS output product only)

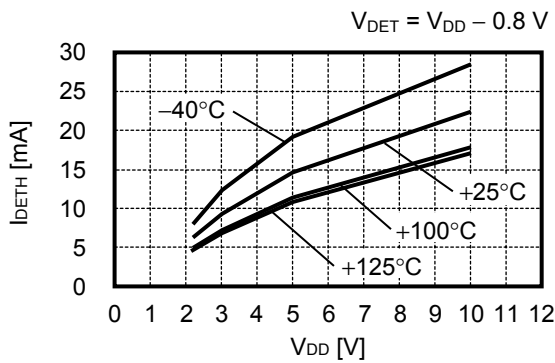

3. DET pin current "L" vs. Power supply voltage characteristics

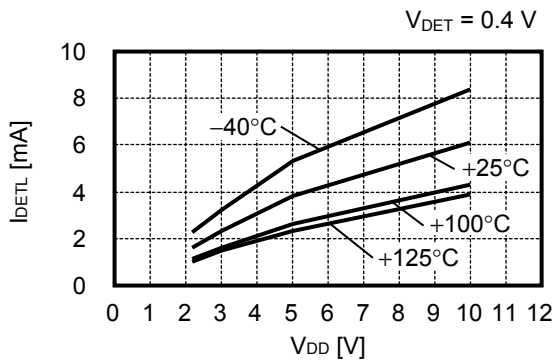

4. Noise suppression time vs. Power supply voltage characteristics

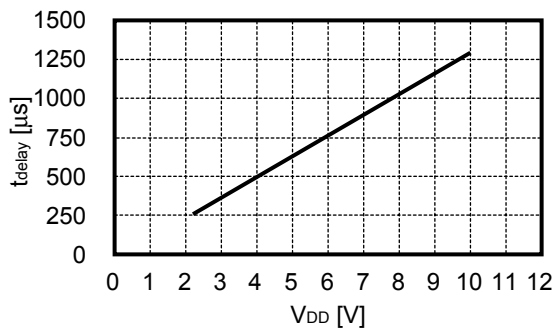



**5. Response against heat (Output voltage vs. Time)**

**5.1 When packages are put into the air of +100 degrees from the air of +25 degrees at t = 0 s**

$V_{DD} = 3.0\text{ V}$ ,  $C_L = 0\ \mu\text{F}$ , Detection temperature =  $+70^\circ\text{C}$ , Active "L"

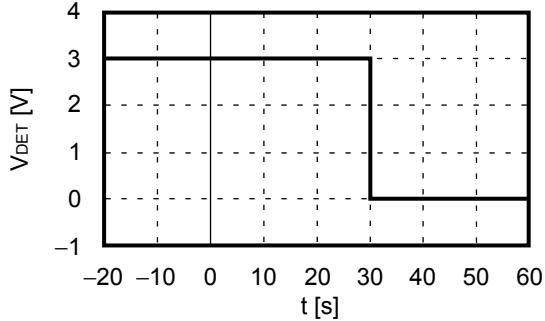

**5.2 When packages are put into the liquid of +100 degrees from the air of +25 degrees at t = 0 s**

$V_{DD} = 3.0\text{ V}$ ,  $C_L = 0\ \mu\text{F}$ , Detection temperature =  $+70^\circ\text{C}$ , Active "L"

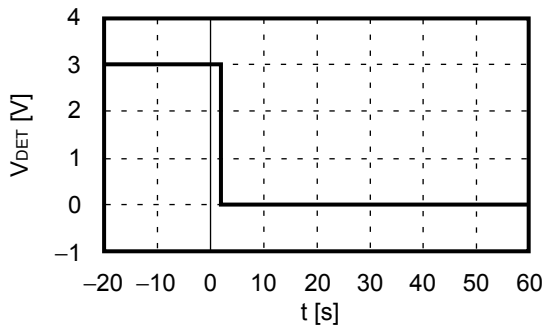

**6. Response against startup**

**6.1 The detection temperature or lower ( $T_a \leq +T_D$ )**

$C_L = 0\ \mu\text{F}$ , Active "L"

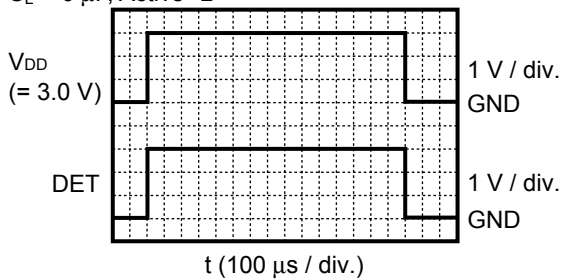

**6.2 Higher than the detection temperature ( $T_a > +T_D$ )**

$C_L = 0\ \mu\text{F}$ , Active "L"

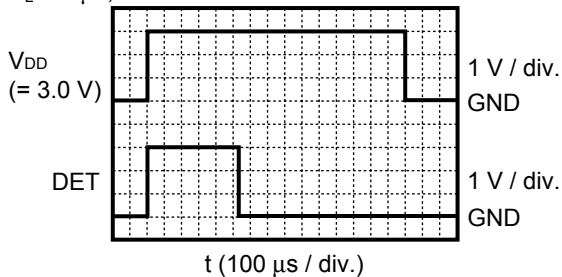

■ Marking Specifications

1. SOT-23-5

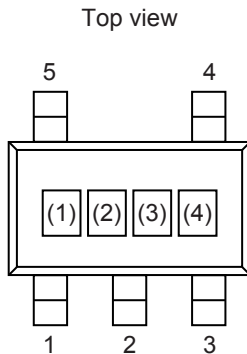

(1) to (3): Product code (refer to **Product name vs. Product code**)  
(4): Lot number

Product name vs. Product code

Product Name	Product Code		
	(1)	(2)	(3)
S-5841A55D-M5T1x	T	H	B
S-5841A65D-M5T1x	T	H	C
S-5841A75D-M5T1x	T	H	D
S-5841A85D-M5T1x	T	H	E
S-5841A95D-M5T1x	T	H	F

Remark1. x: G or U

2. Please select products of environmental code = U for Sn 100%, halogen-free products.

2. SNT-6A

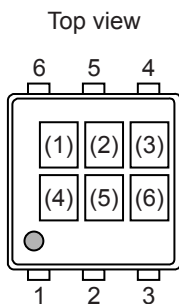

(1) to (3): Product code (refer to **Product name vs. Product code**)  
(4) to (6): Lot number

Product name vs. Product code

Product Name	Product Code		
	(1)	(2)	(3)
S-5841A70A-I6T1U	T	I	G
S-5841A80A-I6T1U	T	I	H
S-5841A90A-I6T1U	T	I	I
S-5841A50D-I6T1U	T	H	A

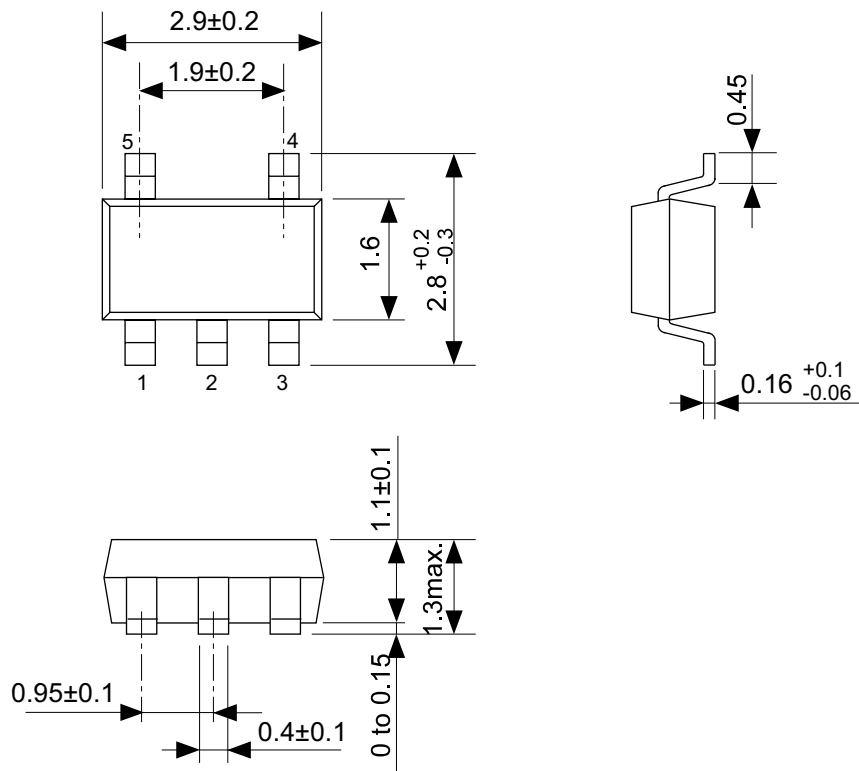

No. MP005-A-P-SD-1.2

TITLE	SOT235-A-PKG Dimensions
No.	MP005-A-P-SD-1.2
SCALE	
UNIT	mm
Seiko Instruments Inc.	

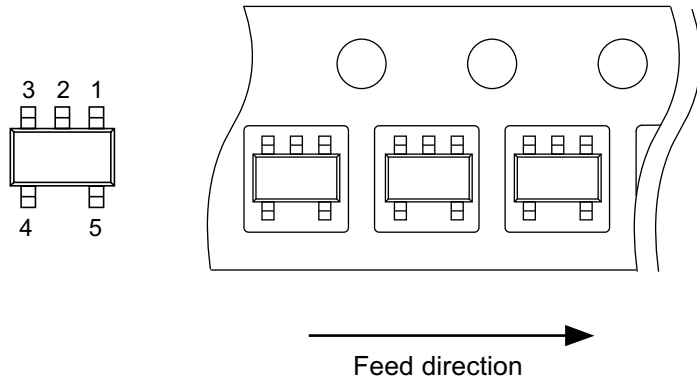
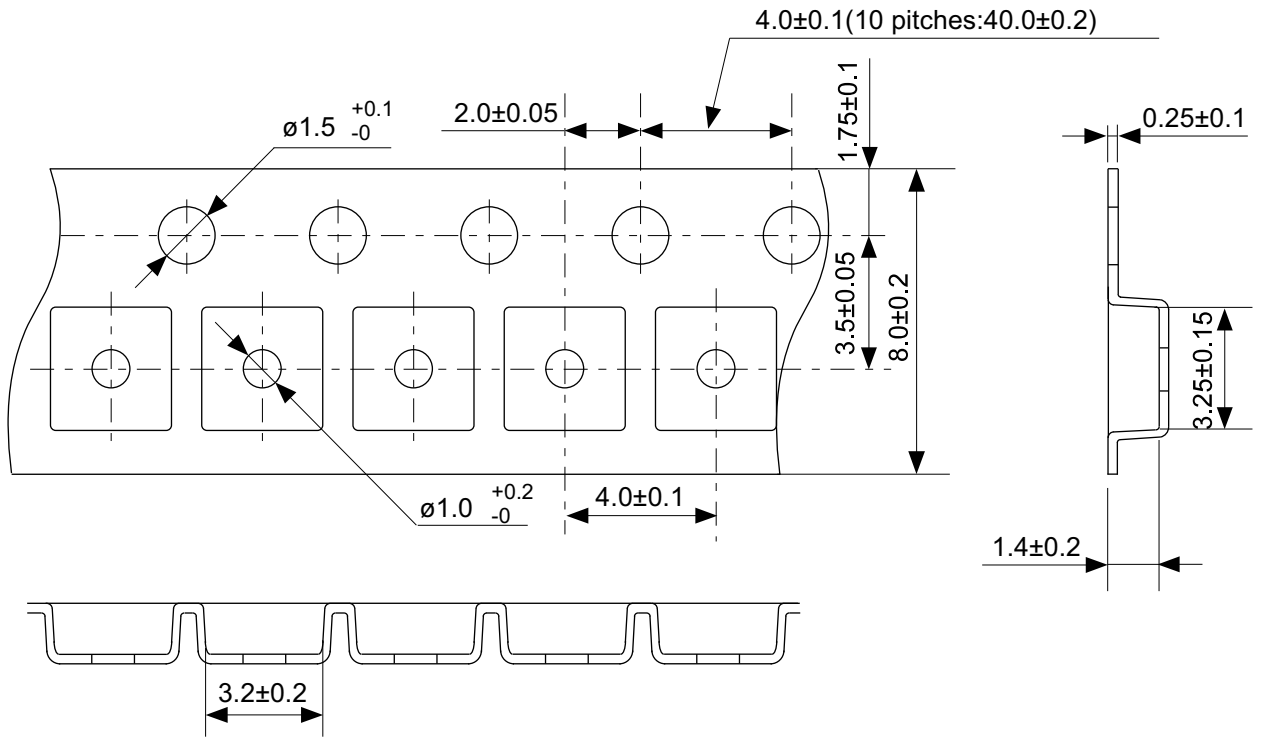

No. MP005-A-C-SD-2.1

TITLE	SOT235-A-Carrier Tape
No.	MP005-A-C-SD-2.1
SCALE	
UNIT	mm
Seiko Instruments Inc.	

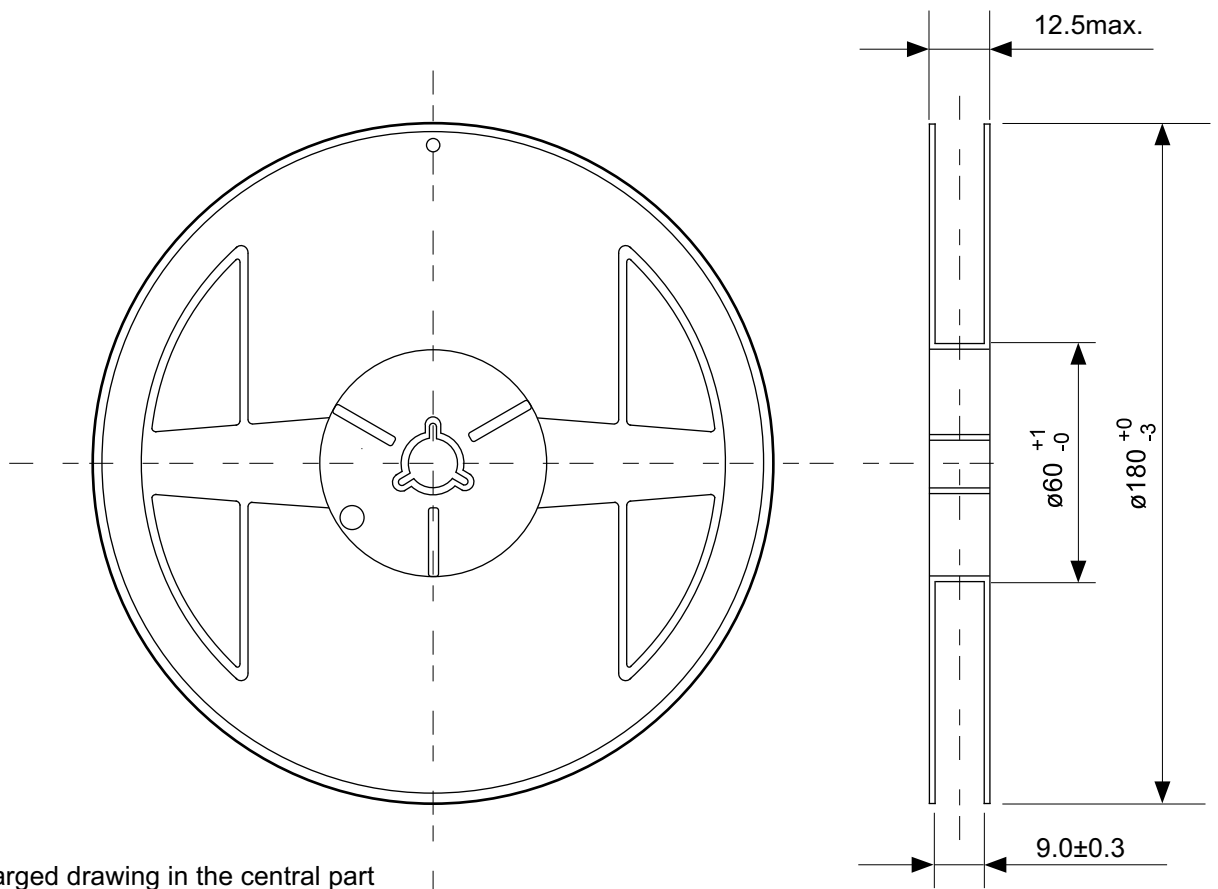

Enlarged drawing in the central part

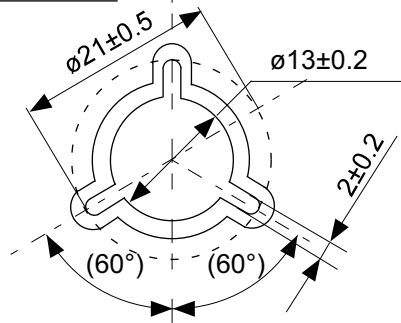

No. MP005-A-R-SD-1.1

TITLE	SOT235-A-Reel		
No.	MP005-A-R-SD-1.1		
SCALE		QTY.	3,000
UNIT	mm		
Seiko Instruments Inc.			

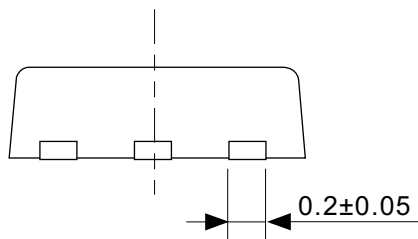
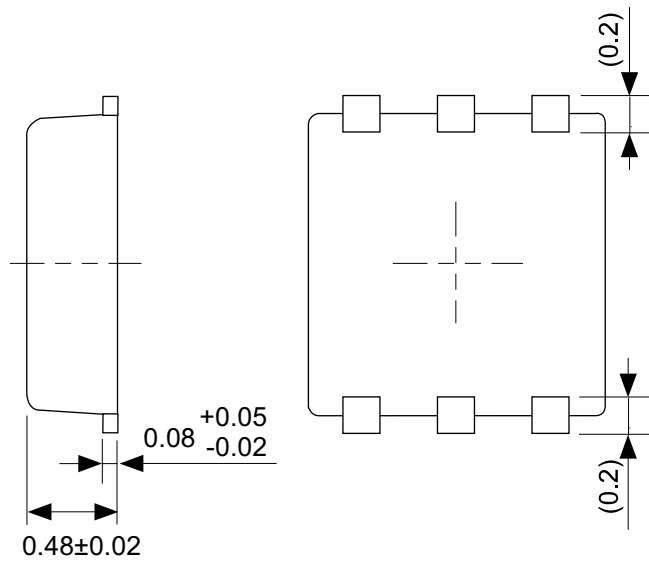
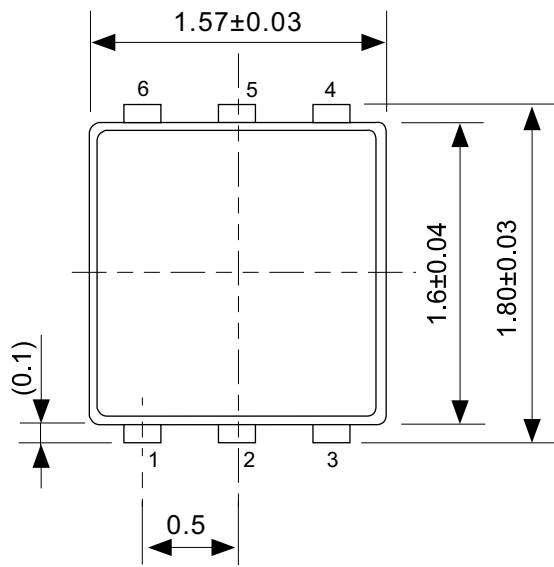

No. PG006-A-P-SD-2.0

TITLE	SNT-6A-A-PKG Dimensions
No.	PG006-A-P-SD-2.0
SCALE	
UNIT	mm
Seiko Instruments Inc.	

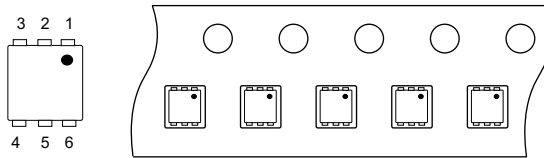
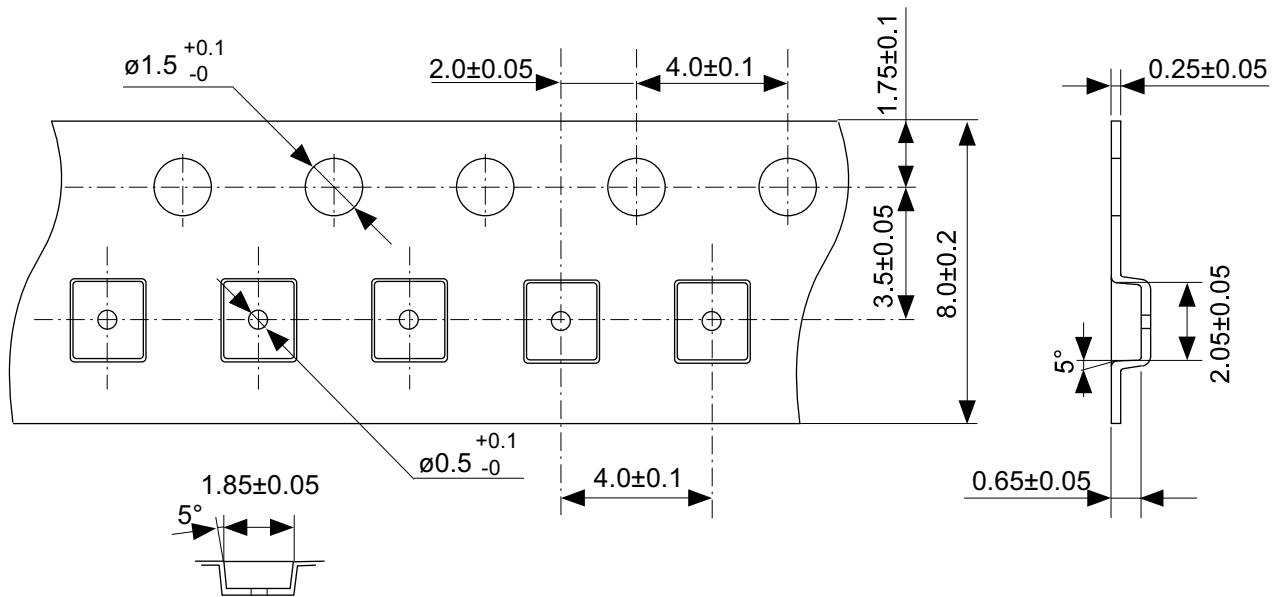

No. PG006-A-C-SD-1.0

TITLE	SNT-6A-A-Carrier Tape
No.	PG006-A-C-SD-1.0
SCALE	
UNIT	mm
Seiko Instruments Inc.	



Enlarged drawing in the central part

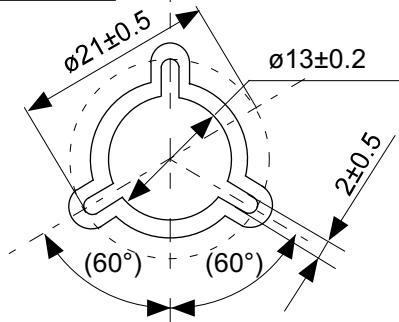

No. PG006-A-R-SD-1.0

TITLE	SNT-6A-A-Reel		
No.	PG006-A-R-SD-1.0		
SCALE		QTY.	5,000
UNIT	mm		
Seiko Instruments Inc.			





※1. ランドパターンの幅に注意してください (0.25 mm min. / 0.30 mm typ.).  
 ※2. パッケージ中央にランドパターンを広げないでください (1.30 mm ~ 1.40 mm)。

- 注意
1. パッケージのモールド樹脂下にシルク印刷やハンダ印刷などしないでください。
  2. パッケージ下の配線上のソルダーレジストなどの厚みをランドパターン表面から0.03 mm 以下にしてください。
  3. マスク開口サイズと開口位置はランドパターンと合わせてください。
  4. 詳細は "SNTパッケージ活用の手引き" を参照してください。

※1. Pay attention to the land pattern width (0.25 mm min. / 0.30 mm typ.).  
 ※2. Do not widen the land pattern to the center of the package ( 1.30 mm ~ 1.40 mm ).

- Caution**
1. Do not do silkscreen printing and solder printing under the mold resin of the package.
  2. The thickness of the solder resist on the wire pattern under the package should be 0.03 mm or less from the land pattern surface.
  3. Match the mask aperture size and aperture position with the land pattern.
  4. Refer to "SNT Package User's Guide" for details.

※1. 请注意焊盘模式的宽度 (0.25 mm min. / 0.30 mm typ.).  
 ※2. 请勿向封装中间扩展焊盘模式 (1.30 mm ~ 1.40 mm)。

- 注意
1. 请勿在树脂型封装的下面印刷丝网、焊锡。
  2. 在封装下、布线上的阻焊膜厚度 (从焊盘模式表面起) 请控制在 0.03 mm 以下。
  3. 钢网的开口尺寸和开口位置请与焊盘模式对齐。
  4. 详细内容请参阅 "SNT 封装的应用指南"。

No. PG006-A-L-SD-4.1

TITLE	SNT-6A-A-Land Recommendation
No.	PG006-A-L-SD-4.1
SCALE	
UNIT	mm
Seiko Instruments Inc.	



Seiko Instruments Inc.  
[www.sii-ic.com](http://www.sii-ic.com)

- The information described herein is subject to change without notice.
- Seiko Instruments Inc. is not responsible for any problems caused by circuits or diagrams described herein whose related industrial properties, patents, or other rights belong to third parties. The application circuit examples explain typical applications of the products, and do not guarantee the success of any specific mass-production design.
- When the products described herein are regulated products subject to the Wassenaar Arrangement or other agreements, they may not be exported without authorization from the appropriate governmental authority.
- Use of the information described herein for other purposes and/or reproduction or copying without the express permission of Seiko Instruments Inc. is strictly prohibited.
- The products described herein cannot be used as part of any device or equipment affecting the human body, such as exercise equipment, medical equipment, security systems, gas equipment, vehicle equipment, in-vehicle equipment, aviation equipment, aerospace equipment, and nuclear-related equipment, without prior written permission of Seiko Instruments Inc.
- The products described herein are not designed to be radiation-proof.
- Although Seiko Instruments Inc. exerts the greatest possible effort to ensure high quality and reliability, the failure or malfunction of semiconductor products may occur. The user of these products should therefore give thorough consideration to safety design, including redundancy, fire-prevention measures, and malfunction prevention, to prevent any accidents, fires, or community damage that may ensue.