

Small Signal MOSFET

30 V, 154 mA, Single, N-Channel, Gate ESD Protection, SC-89

Features

- Low Gate Charge for Fast Switching
- Small 1.6 X 1.6 mm Footprint
- ESD Protected Gate
- We declare that the material of product is ROHS compliant and halogen free.
- ESD Protected:2000V
- S- Prefix for Automotive and Other Applications Requiring Unique Site and Control Change Requirements; AEC-Q101 Qualified and PPAP Capable.

Applications

- Power Management Load Switch
- Level Shift
- Portable Applications such as Cell Phones, Media Players, Digital Cameras, PDA's, Video Games, Hand Held Computers, etc.

MAXIMUM RATINGS (T_J = 25°C unless otherwise noted)

| Parameter | Symbol | Value | Unit |
|---|-----------------------------------|------------|------|
| Drain-to-Source Voltage | V _{DSS} | 30 | V |
| Gate-to-Source Voltage | V _{GS} | ± 10 | V |
| Continuous Drain Current (Note 1) | I _D | 154 | mA |
| Power Dissipation (Note 1) | P _D | 300 | mW |
| Pulsed Drain Current | I _{DM} | 618 | mA |
| Operating Junction and Storage Temperature | T _J , T _{STG} | -55 to 150 | °C |
| Continuous Source Current (Body Diode) | I _{SD} | 154 | mA |
| Lead Temperature for Soldering Purposes (1/8" from case for 10 s) | T _L | 260 | °C |

THERMAL RESISTANCE RATINGS

| Parameter | Symbol | Max | Unit |
|---|------------------|-----|------|
| Junction-to-Ambient – Steady State (Note 1) | R _{θJA} | 416 | °C/W |

Maximum ratings are those values beyond which device damage can occur. Maximum ratings applied to the device are individual stress limit values (not normal operating conditions) and are not valid simultaneously. If these limits are exceeded, device functional operation is not implied, damage may occur and reliability may be affected.

1. Surface-mounted on FR4 board using 1 in sq pad size (Cu area = 1.127 in sq [1 oz] including traces).

**LNTA7002NT1G
S-LNTA7002NT1G**

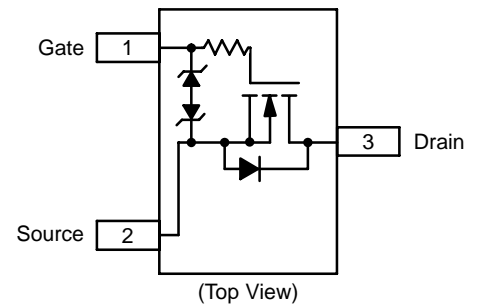
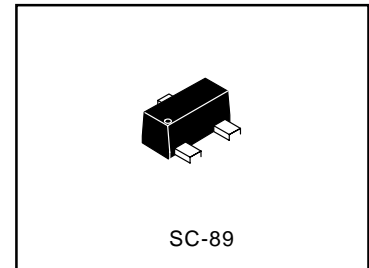

MARKING DIAGRAM

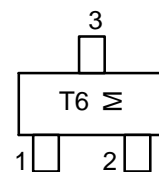

T6 = Specific Device Code
M = Month Code

ORDERING INFORMATION

| Device | Marking | Shipping |
|--------------------------------|---------|-----------------|
| LNTA7002NT1G S-LNTA7002NT1G | T6 | 3000/Tape&Reel |
| LNTA7002NT3G S-LNTA7002NT3G | T6 | 10000/Tape&Reel |

LNTA7002NT1G , S-LNTA7002NT1G

ELECTRICAL CHARACTERISTICS ($T_J = 25^\circ\text{C}$ unless otherwise specified)

| Parameter | Symbol | Test Condition | Min | Typ | Max | Unit |
|-----------------------------------|---------------|--|-----|-----|-----------|---------------|
| OFF CHARACTERISTICS | | | | | | |
| Drain-to-Source Breakdown Voltage | $V_{(BR)DSS}$ | $V_{GS} = 0\text{ V}, I_D = 100\ \mu\text{A}$ | 30 | | | V |
| Zero Gate Voltage Drain Current | I_{DSS} | $V_{GS} = 0\text{ V}, V_{DS} = 30\text{ V}$ | | | 1.0 | μA |
| Zero Gate Voltage Drain Current | I_{DSS} | $V_{GS} = 0\text{ V}, V_{DS} = 20\text{ V}, T = 85^\circ\text{C}$ | | | 1.0 | μA |
| Gate-to-Source Leakage Current | I_{GSS} | $V_{DS} = 0\text{ V}, V_{GS} = \pm 10\text{ V}$ | | | ± 25 | μA |
| Gate-to-Source Leakage Current | I_{GSS} | $V_{DS} = 0\text{ V}, V_{GS} = \pm 5\text{ V}$ | | | ± 1.0 | μA |
| Gate-to-Source Leakage Current | I_{GSS} | $V_{DS} = 0\text{ V}, V_{GS} = \pm 5\text{ V}, T = 85^\circ\text{C}$ | | | ± 1.0 | μA |

ON CHARACTERISTICS (Note 2)

| | | | | | | |
|-------------------------------|--------------|--|-----|-----|-----|----------|
| Gate Threshold Voltage | $V_{GS(TH)}$ | $V_{DS} = V_{GS}, I_D = 100\ \mu\text{A}$ | 0.5 | 1.0 | 1.5 | V |
| Drain-to-Source On Resistance | $R_{DS(on)}$ | $V_{GS} = 4.5\text{ V}, I_D = 154\text{ mA}$ | | 1.4 | 7.0 | Ω |
| | | $V_{GS} = 2.5\text{ V}, I_D = 154\text{ mA}$ | | 2.3 | 7.5 | |
| Forward Transconductance | g_{FS} | $V_{DS} = 3\text{ V}, I_D = 154\text{ mA}$ | | 80 | | mS |

CAPACITANCES

| | | | | | | |
|------------------------------|-----------|--|--|------|--|---------------|
| Input Capacitance | C_{ISS} | $V_{DS} = 5.0\text{ V}, f = 1\text{ MHz}, V_{GS} = 0\text{ V}$ | | 11.5 | | μF |
| Output Capacitance | C_{OSS} | | | 10 | | |
| Reverse Transfer Capacitance | C_{RSS} | | | 3.5 | | |

SWITCHING CHARACTERISTICS (Note 3)

| | | | | | | |
|---------------------|--------------|--|--|----|--|----|
| Turn-On Delay Time | $t_{d(ON)}$ | $V_{GS} = 4.5\text{ V}, V_{DS} = 5.0\text{ V}, I_D = 75\text{ mA}, R_G = 10\ \Omega$ | | 13 | | ns |
| Rise Time | t_r | | | 15 | | |
| Turn-Off Delay Time | $t_{d(OFF)}$ | | | 98 | | |
| Fall Time | t_f | | | 60 | | |

Drain-Source Diode Characteristics

| | | | | | | |
|-----------------------|----------|--|--|------|-----|---|
| Forward Diode Voltage | V_{SD} | $V_{GS} = 0\text{ V}, I_S = 0.154\text{ mA}$ | | 0.77 | 0.9 | V |
|-----------------------|----------|--|--|------|-----|---|

2. Pulse Test: pulse width $\leq 300\ \mu\text{s}$, duty cycle $\leq 2\%$.

3. Switching characteristics are independent of operating junction temperatures.

LNTA7002NT1G , S-LNTA7002NT1G

TYPICAL PERFORMANCE CURVES

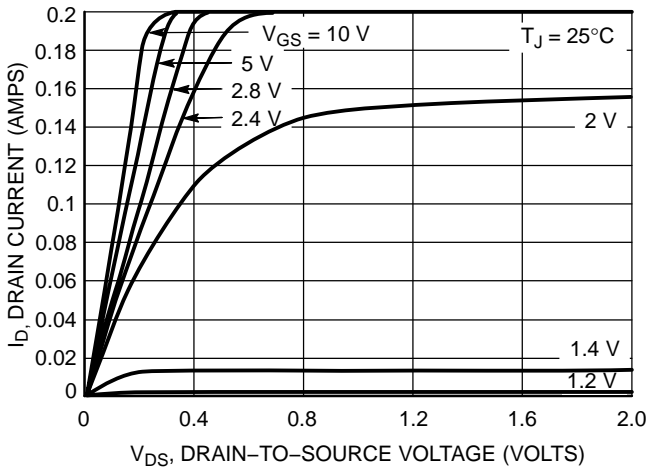

Figure 1. On-Region Characteristics

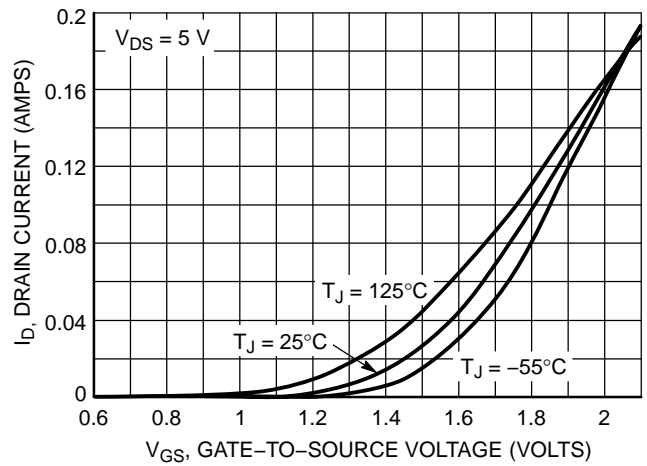

Figure 2. Transfer Characteristics

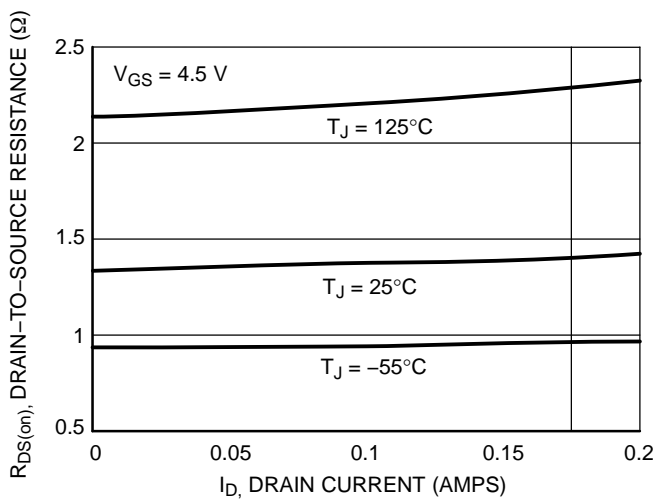

Figure 3. On-Resistance vs. Drain Current and Temperature

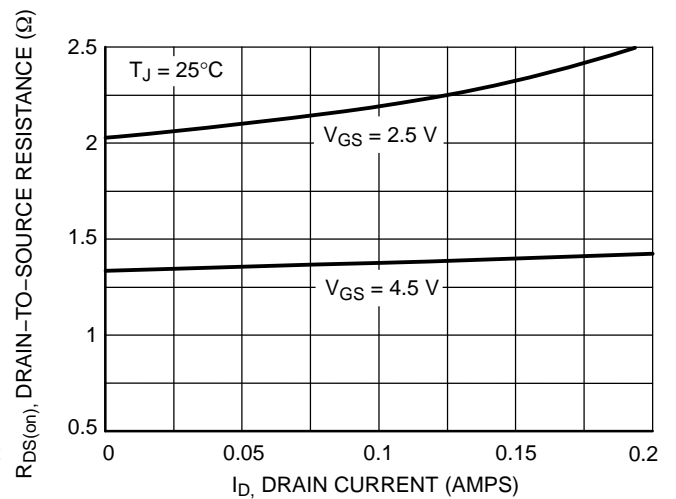

Figure 4. On-Resistance vs. Drain Current and Gate Voltage

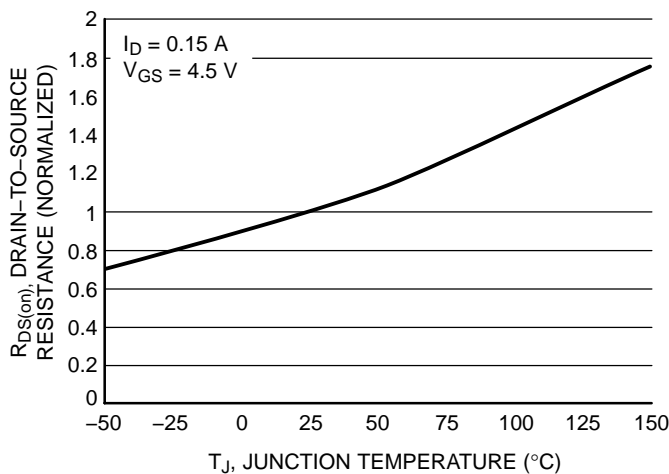

Figure 5. On-Resistance Variation with Temperature

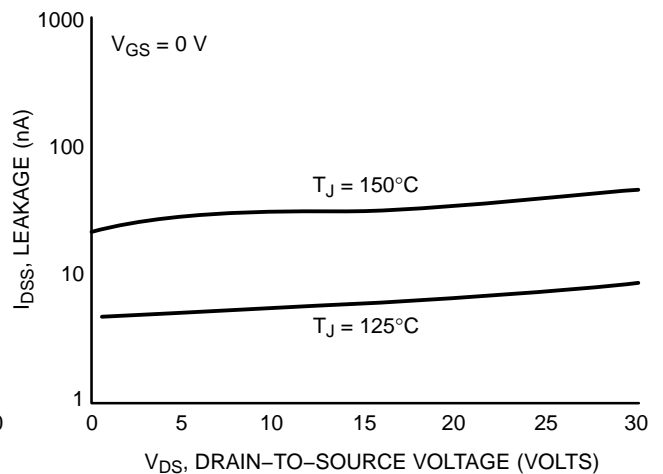

Figure 6. Drain-to-Source Leakage Current vs. Voltage

LNTA7002NT1G , S-LNTA7002NT1G

TYPICAL PERFORMANCE CURVES

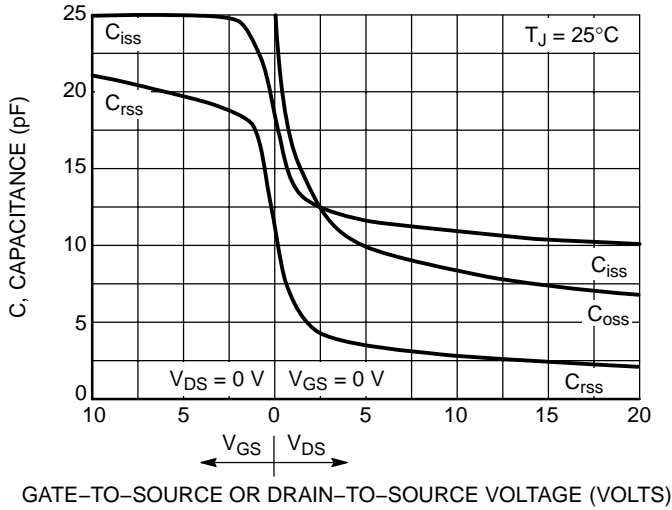

Figure 7. Capacitance Variation

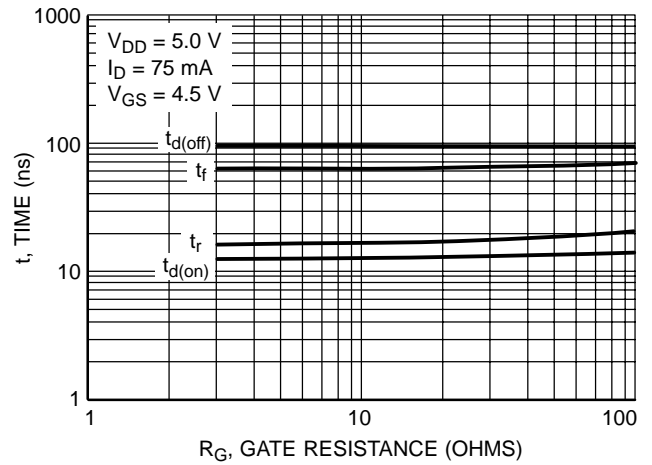

Figure 8. Resistive Switching Time Variation vs. Gate Resistance

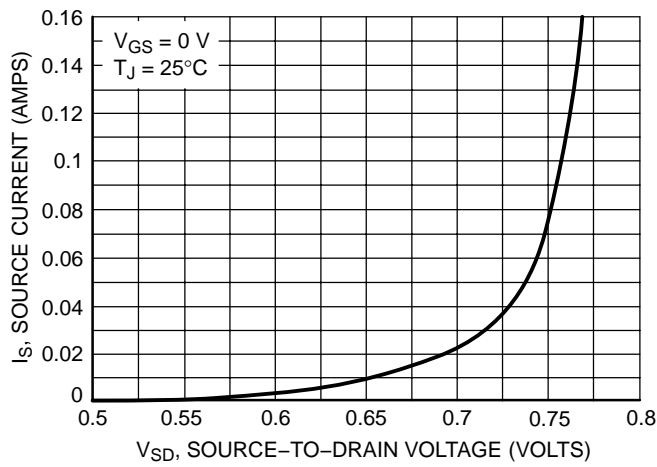
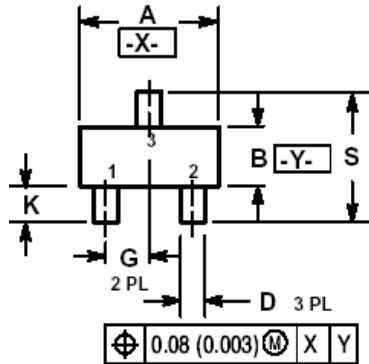

Figure 9. Diode Forward Voltage vs. Current

LNTA7002NT1G , S-LNTA7002NT1G

SC-89



NOTES:

1. DIMENSIONING AND TOLERANCING PER ANSI Y14.5M, 1982.
2. CONTROLLING DIMENSION: MILLIMETERS
3. MAXIMUM LEAD THICKNESS INCLUDES LEAD FINISH THICKNESS. MINIMUM LEAD THICKNESS IS THE MINIMUM THICKNESS OF BASE MATERIAL.
4. 463C-01 OBSOLETE, NEW STANDARD 463C-02.

| DIM | MILLIMETERS | | | INCHES | | |
|-----|-------------|------|------|-----------|-------|-------|
| | MIN | NOM | MAX | MIN | NOM | MAX |
| A | 1.50 | 1.60 | 1.70 | 0.059 | 0.063 | 0.067 |
| B | 0.75 | 0.85 | 0.95 | 0.030 | 0.034 | 0.040 |
| C | 0.60 | 0.70 | 0.80 | 0.024 | 0.028 | 0.031 |
| D | 0.23 | 0.28 | 0.33 | 0.009 | 0.011 | 0.013 |
| G | 0.50 BSC | | | 0.020 BSC | | |
| H | 0.53 REF | | | 0.021 REF | | |
| J | 0.10 | 0.15 | 0.20 | 0.004 | 0.006 | 0.008 |
| K | 0.30 | 0.40 | 0.50 | 0.012 | 0.016 | 0.020 |
| L | 1.10 REF | | | 0.043 REF | | |
| M | --- | --- | 10 ° | --- | --- | 10 ° |
| N | --- | --- | 10 ° | --- | --- | 10 ° |
| S | 1.50 | 1.60 | 1.70 | 0.059 | 0.063 | 0.067 |

