

CDTech(H.K.)Electronics Limited

Product Specifications

Customer	Standard Model
Model Name	S039WQ01
Description	TFT LCD Module 3.9" WQVGA 480(RGB)x128 Dots
Date	2015/09/14
Version	V5.0

Customer Approval

Date	
The above signature represents that the product specifications, testing regulation, and warranty in the specifications are accepted	

Engineering

Approved	Date	Prepared	Date
<i>Sam Huang</i>	2015.9.14	<i>Rich Liang</i>	2015.9.14

Table of Contents

1. Record of Revision	3
2 General Specifications	4
3 Input/Output Terminals	5
4.Absolute Maximum Ratings.....	6
5. Electrical Characteristics	7
6. Interface Timing	9
7.Optical Characteristics.....	12
8. Environmental / Reliability Tests.....	15
9. Mechanical Drawing	16
10.Packing.....	17
11. Precautions For Use of LCD modules.....	18

CDTech Electronics
www.cdtechhk.com

CDTech(H.K.)Electronics Limited

1. Record of Revision

Rev	Issued Date	Description	Editor
1.0	2014/8/14	First Release.	Rich Liang
2.0	2015/07/07	Update Spec	Rich Liang
3.0	2015/07/17	Add LED life time	Rich Liang
4.0	2015/09/09	Update Spec	Rich Liang
5.0	2015/09/14	Update HV mode	Rich Liang

2 General Specifications

	Feature	Spec
Characteristics	Size	3.9 inch
	Resolution	480(horizontal)*128(Vertical)
	Interface	RGB 24bit (HV mode)
	Connect type	Connector
	Color Depth	24bit
	Technology type	a-Si
	Pixel pitch (mm)	0.198 x 0.198
	Length Width Ratio	4 : 1
	Pixel Configuration	R.G.B. Stripe
	Display Mode	Normally White
	Driver IC	ILI6480
	Luminance	500nits
	Viewing Direction	12:00 O'clock
	Gray Scale Inversion Direction	6 O'clock
Mechanical	LCM (W x H x D) (mm)	105.5*40.64*2.95
	Active Area(mm)	95.04 x 25.34
	With /Without TSP	Without
	LED Numbers	10 LEDs (5S2P)
	LED Lifetime	20000 Hrs

Note 1: Viewing direction for best image quality is different from TFT definition, there is a 180 degree shift.

Note 2: Requirements on Environmental Protection: RoHS

Note 3: LCM weight tolerance: +/- 5%

3 Input/Output Terminals

No.	Symbol	Description
1	VBL-	Backlight LED Cathode
2	VBL+	Backlight LED Anode.
3	GND	System Ground
4	VCC	Power supply for logic operation
5~12	R0~R7	Data bus
13~20	G0~G7	Data bus
21~28	B0~B7	Data bus
29	GND	System Ground
30	CLK	Pixel clock signal
31	DISP	Display on/off control
32	HSYNC	Horizontal Sync signal
33	VSYNC	Vertical Sync signal
34	DEN	Data Enable Remark: internal pulled weak low
35	NC	No connection
36	GND	System Ground
37	XR(NC)	The right side signal of TP
38	YD(NC)	The down side signal of TP
39	XL(NC)	The left side signal of TP
40	YU(NC)	The up side signal of TP

4. Absolute Maximum Ratings

Recommended Operating Range

(GND=AGND=PGND=0V, TA= -20 to +85°C)

Parameters	Symbol	Min.	Typ.	Max.	Unit	Conditions
Digital Supply Voltage	VDD	3.0	3.3	3.6	V	
Charge Pump Supply Voltage	PVDD	3.0	3.3	3.6	V	
Digital interface supply Voltage	VDDIO	1.8	-	VDD	V	
Digital Input Voltage	Din	0	-	VDDIO	V	
OTP Supply Voltage	VPP_OTP	-	6	-	V	
VCOM AC Voltage	VCOMH - VCOML	2.96	-	6.2	V	

Item	Symbol	MIN	MAX	Unit	Remark
Operating Temperature	T _{OPR}	-20	70	°C	
Storage Temperature	T _{STG}	-30	80	°C	

5. Electrical Characteristics

5.1 DC Electrical Characteristics

(VDDIO=VDD=3.0 to 3.6V, GND=AGND=PGND=0V, TA= -20 to 85 °C)

Parameters	Symbol	Min.	Typ.	Max.	Unit	Conditions
Digital Block Circuit						
Low Level Input Voltage	Vil	GND	-	0.3xVDDIO	V	Digital input pins
High Level Input Voltage	Vih	0.7xVDDIO	-	VDDIO	V	Digital input pins
Input Leakage Current	Ii	-	-	±1	uA	Digital input pins
Pull-high/low Impedance	Rin	-	200K	-	ohm	Digital control input pins VDDIO=3.3V
High Level Output Voltage	Voh	VDDIO-0.4	-	-	V	Digital output pins Ioh=400uA
Low Level Output Voltage	Vol	GND	-	GND+0.4	V	Digital output pins Iol=-400uA
Digital Stand-by Current	I _{dst}	-	TBD	TBD	uA	Output are High-Z, all pins are default
Digital Operating Current	I _{cc}	-	TBD	-	mA	DCLK=9MHz, Fid=17.28KHz (@ 24bit RGB mode), no load
Analog Block Circuit						
Analog Supply Voltage	AVDD	-	5.2	5.6	V	
GAMMA reference voltage	VDDA	-	5	-	V	
Step-up Circuit 1 Output Voltage	VINT1	5.8	-	-	V	
VCOMH Output Level	VCOMH	2.46	-	5	V	By VCOMH[6:0] setting
VCOML Output Level	VCOML	-3	-	-0.46	V	By VCOML[6:0] setting; VCOML>VINT3
Feed back voltage for PWM	VFB	0.25 0.6 0.8 V	-	-	-	DC-DC operating.
Base drive current for PWM	I _{DRV}	-	20	-	mA	VDD=3.3V

Voltage Deviation of Outputs	V _{vd}	-	±20	±35	mV	Vo=0.1V ~ 0.5V & AVDD-0.5 ~ AVDD-0.1
		-	±15	±20	mV	Vo=0.5V ~ AVDD-0.5V
Dynamic Range of Output	V _{dr}	0.1	-	AVDD-0.1	V	S1 to S720
Low-level Output Current of VCOM	I _{OLC}	-	TBD	-	mA	VCOMH=4V, VCOML=-1V VCOM output=-1V V.S. -0.1V
High-level Output Current of VCOM	I _{OHc}	-	TBD	-	mA	VCOMH=4V, VCOML=-1V VCOM output=4V V.S. 3.1V
Source Low-level Output Current	I _{OLS}	TBD	-	-	uA	S1 to S720; Vo=0.1 V.S. 1V
Source High-level Output Current	I _{OHS}	TBD	-	-	uA	S1 to S720; Vo=4.9 V.S 4.0
Gate Low-level Output Current	I _{OLG}	TBD	-	-	uA	G1 to G544; Vo=VGL V.S. VGL+0.5
Gate High-level Output Current	I _{OHG}	TBD	-	-	uA	G1 to G544; Vo=VGH V.S. VGH-0.5
Analog Stand-by Current	I _{ast}	-	-	100	uA	STB="L", all function are shutdown
Analog Operating Current	I _{DD}	-	TBD	-	mA	DCLK=9MHz, Fid=17.28KHz (@ 24bit RGB mode), No load

5.2 Driving Backlight

Item	Symbol	MIN	TYP	MAX	Unit	Remark
Forward Current	I_F	-	40	50	mA	
Forward Voltage	V_F	-	16	16.5	V	
Backlight Power consumption	W_{BL}	-	0.64	0.825	W	
LED life time		-	-	20000	Hrs	

Note 1: Each LED : $I_F = 20\text{ mA}$, $V_F = 3.2\text{V}$.

Note 2: Optical performance should be evaluated at $T_a = 25^\circ\text{C}$ only.

Note 3: If LED is driven by high current, high ambient temperature & humidity condition. The life time of LED will be reduced. Operating life means brightness goes down to 50% initial brightness. Typical operating life time is estimated data.

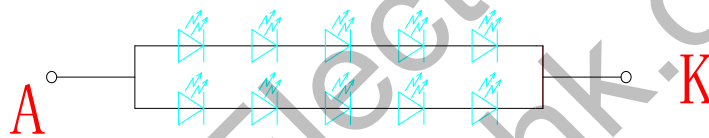
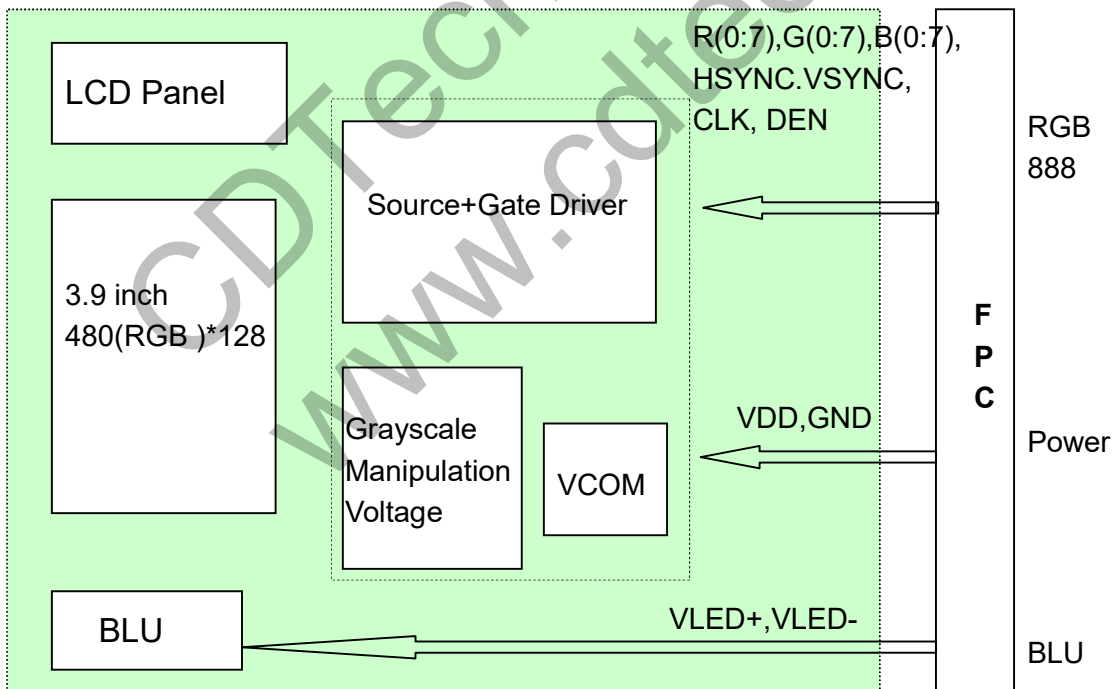

Figure : LED connection of backlight

5.3 Block Diagram



6 Interface Timing

6.1 Clock and Data input Waveforms

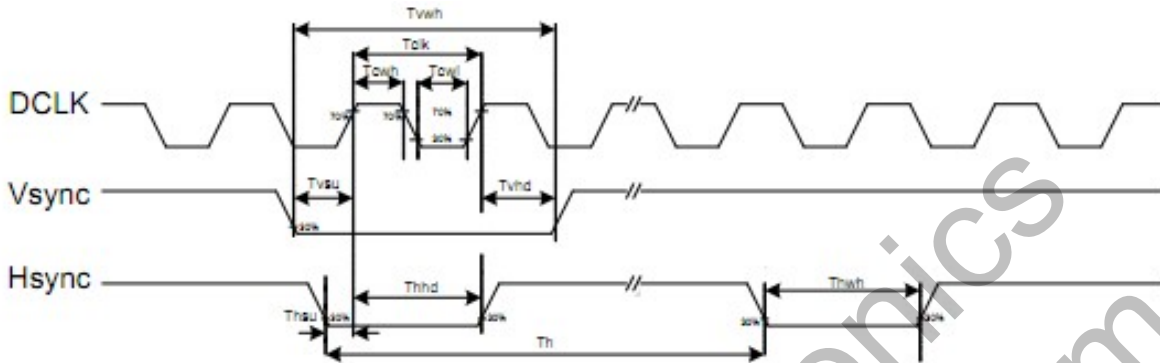

6.2 Data input Format

Vertical input timing

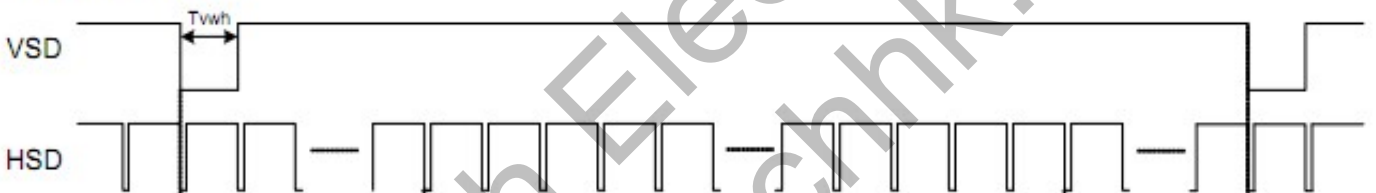

Parameters	Symbol	Min.	Typ.	Max.	Unit	Conditions
DCLK frequency	Fclk	24	27	30	MHz	
DCLK cycle time	Tolk	83	110	200	ns	
DCLK pulse duty	Tcwh	40	50	60	%	
Time from HSD to source output	Thso	-	13	-	DCLK	
Time from HSD to gate output	Thgo	-	27	-	DCLK	
Time from HSD to gate output off	Thgz	-	3	-	DCLK	
Time from HSD to VCOM	Thvc	-	12	-	DCLK	

CDTech(H.K.)Electronics Limited

Parallel RGB Mode Data format

(HV Mode)

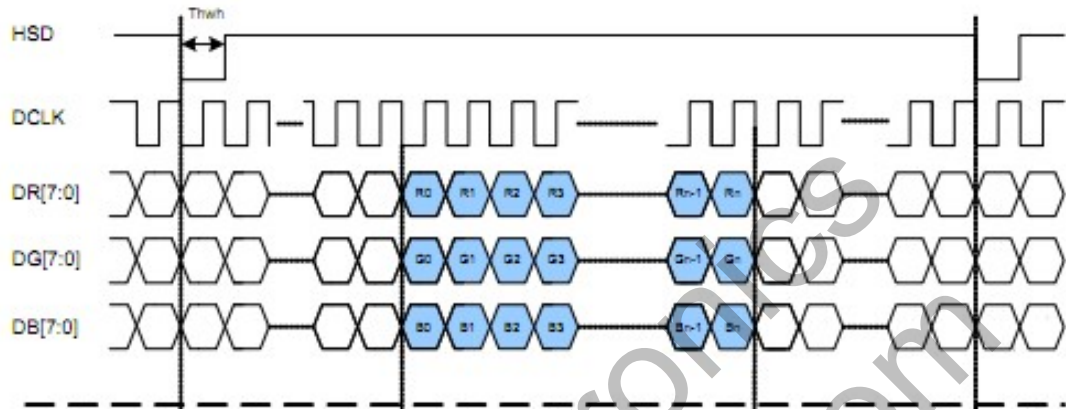

Parallel RGB input timign table

Parameter	Symbol	Value			Unit
		Min.	Typ.	Max.	
DCLK frequency	fclk	5	9	12	MHz
VSD period time	Tv	277	288	400	H
VSD display area	Tvd	272			H
VSD back porch	Tvb	3	8	31	H
VSD front porch	Tvfp	2	8	97	H
HSD period time	Th	520	525	800	DCLK
HSD display area	Thd	480			DCLK
HSD back porch	Thbp	36	40	255	DCLK
HSD front porch	Thfp	4	5	65	DCLK

Output Timing Diagram

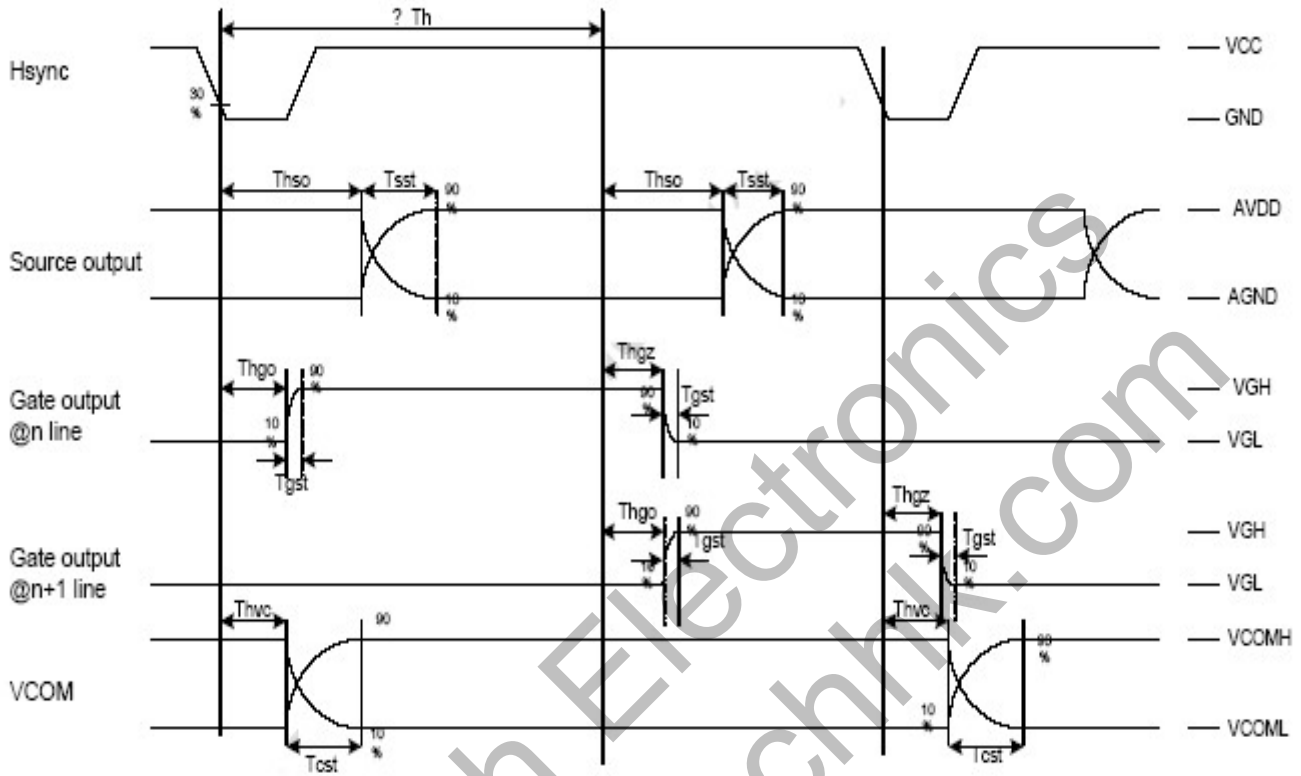

7 Optical Characteristics

Items		Symbol	Condition	Min.	Typ.	Max.	Unit	Remark
Viewing angles		θ_T	Center CR \geq 10	40	55	-	Degree.	Note2
		θ_B		60	65	-		
		θ_L		60	65	-		
		θ_R		60	65	-		
Contrast Ratio		CR	$\Theta = 0$	400	500	-	-	Note1, Note3
Response Time		T_{ON}	25°C	-	10	20	ms	Note1, Note4
		T_{OFF}		-	15	30		
Chromaticity	White	X_W	Backlight is on	0.26	0.31	0.36	-	Note1, Note5
		Y_W		0.28	0.33	0.38	-	
Uniformity		U		75	80	-	%	Note1, Note6
NTSC					50		%	Note5
Luminance		L		400	500	-	Nits	Note1, Note6 Note7

Test Conditions:

1. IF= 20mA(one channel),the ambient temperature is 25°C.
2. The test systems refer to Note 1 and Note 2.

Note 1:Definition of optical measurement system.

The optical characteristics should be measured in dark room. After 5 minutes operation, the optical properties are measured at the center point of the LCD screen. All input terminals LCD panel must be ground when measuring the center area of the panel.

CDTech(H.K.)Electronics Limited

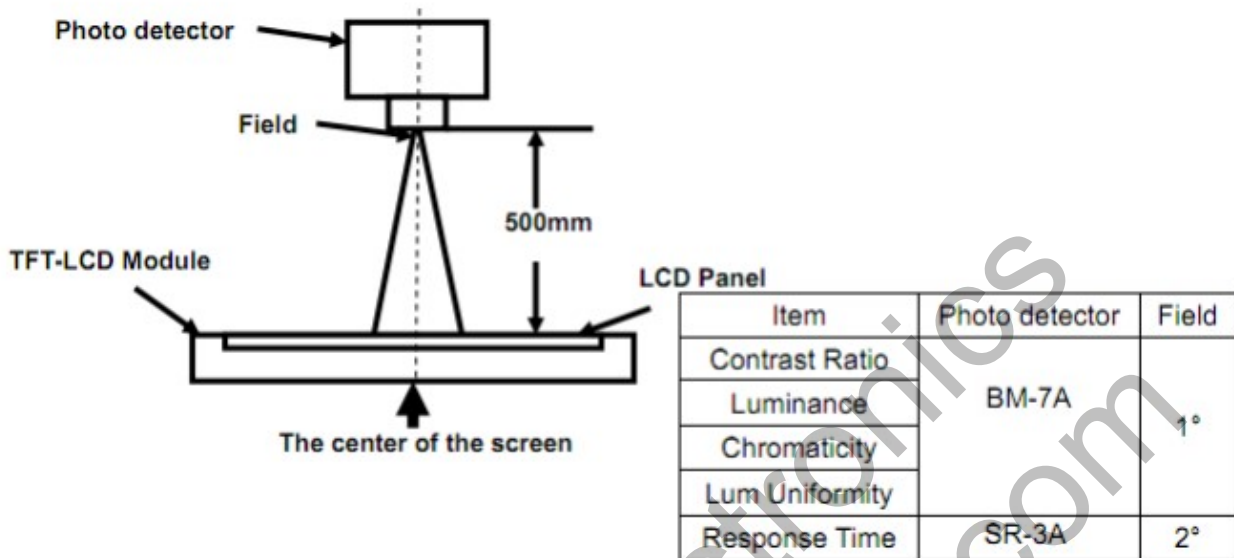

Note 2: Definition of viewing angle range and measurement system.
viewing angle is measured at the center point of the LCD by CONOSCOPE(ergo-80).

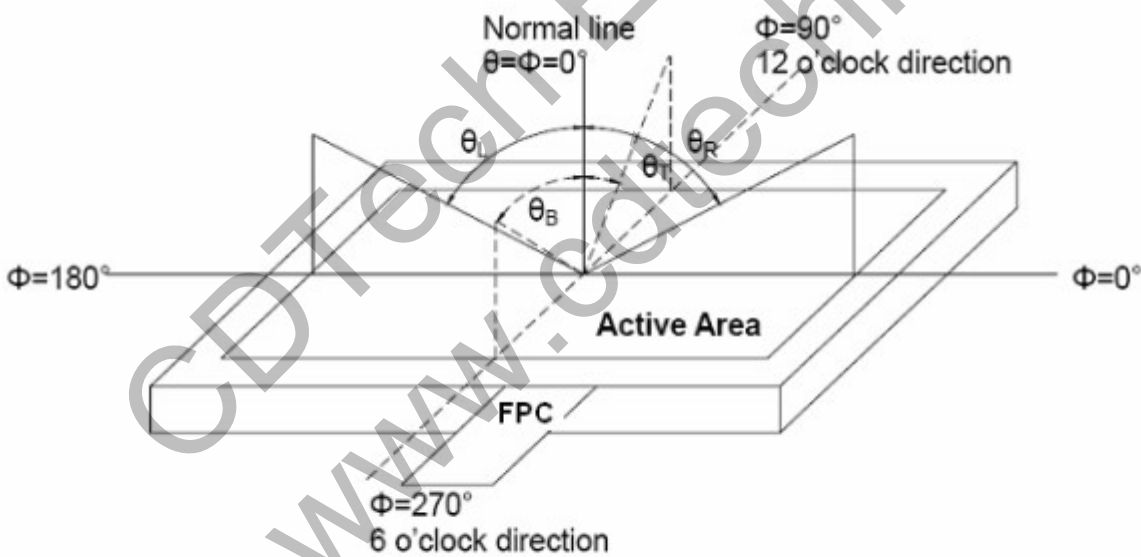

Fig. 1 Definition of viewing angle

Note 3: Definition of contrast ratio

$$\text{Contrast ratio (CR)} = \frac{\text{Luminance measured when LCD is on the "White" state}}{\text{Luminance measured when LCD is on the "Black" state}}$$

“White state “:The state is that the LCD should driven by Vwhite.

CDTech(H.K.)Electronics Limited

“Black state”: The state is that the LCD should driven by Vblack.

Vwhite: To be determined Vblack: To be determined.

Note 4: Definition of Response time

The response time is defined as the LCD optical switching time interval between “White” state and “Black” state. Rise time (TON) is the time between photo detector output intensity changed from 90% to 10%. And fall time (TOFF) is the time between photo detector output intensity changed from 10% to 90%.

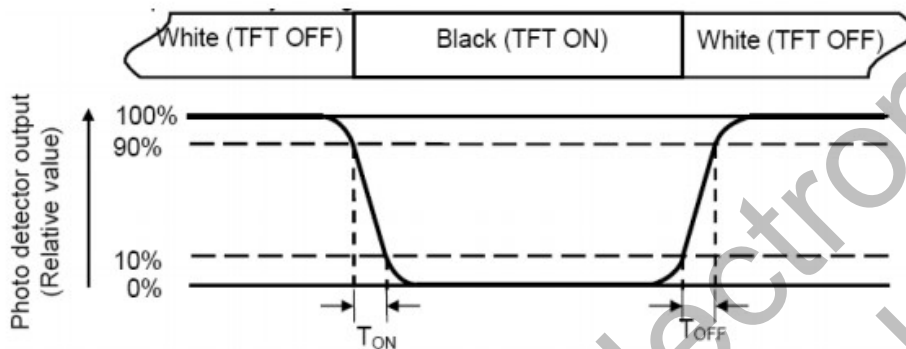

Note 5: Definition of color chromaticity (CIE1931)

Color coordinates measured at center point of LCD.

Note 6: Definition of Luminance Uniformity

Active area is divided into 3 measuring areas (Refer Fig. 2). Every measuring point is placed at the center of each measuring area.

$$\text{Luminance Uniformity}(U) = L_{\min} / L_{\max} \times 100\%$$

L-----Active area length W----- Active area width

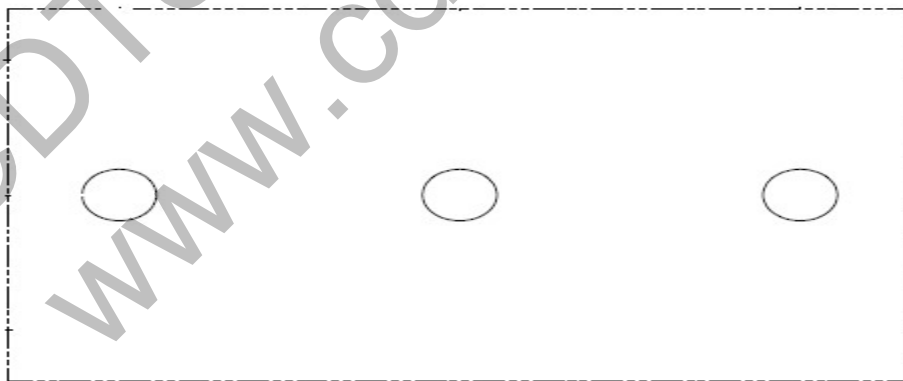

Fig. 2 Definition of uniformity

Lmax: The measured maximum luminance of all measurement position.

Lmin: The measured minimum luminance of all measurement position.

Note 7: Definition of Luminance :

Measure the luminance of white state at center point.

12 pcs each testing (Note 6, 7) item

8 Environmental / Reliability Tests

No	Test Item	Condition	Remarks
1	High Temperature Operation	T _s = +70°C, 240hrs	Note 1 IEC60068-2-2, GB2423. 2-89
2	Low Temperature Operation	T _a = -20°C, 240hrs	Note 2 IEC60068-2-1 GB2423.1-89
3	High Temperature Storage	T _a = +80°C, 240hrs	IEC60068-2-2 GB2423. 2-89
4	Low Temperature Storage	T _a = -30°C, 240hrs	IEC60068-2-1 GB/T2423.1-89
5	High Temperature & Humidity Storage	T _a = +60°C, 90% RH max, 160 hours	IEC60068-2-3 GB/T2423.3-2006
6	Thermal Shock (Non-operation)	-30°C 30 min ~ +80°C 30 min Change time: 5min, 30 Cycle	Start with cold temperature, end with high temperature IEC60068-2-14, GB2423.22-87
7	Electro Static Discharge (Operation)	C=150pF, R=330 Ω, 5 points/panel Air:±8KV, 5 times; Contact: ±4KV, 5 times; (Environment: 15°C ~ 35°C, 30% ~ 60%, 86Kpa ~ 106Kpa)	IEC61000-4-2 GB/T17626.2-1998
8	Vibration (Non-operation)	Frequency range: 10~55Hz, Stroke: 1.mm Sweep: 10Hz~55Hz~10Hz 2 hours for each direction of X .Y. Z. (package condition)	IEC60068-2-6 GB/T2423.5-1995
9	Shock (Non-operation)	60G 6ms, ± X, ±Y , ± Z 3 times for each direction	IEC60068-2-27 GB/T2423.5-1995
10	Package Drop Test	Height: 80 cm, 1 corner, 3 edges, 6 surfaces	IEC60068-2-32 GB/T2423.8-1995

Note: 1. T_S is the temperature of panel's surface.

2. T_a is the ambient temperature of sample.

3).12 pcs each testing (1~8) item

9 Mechanical Drawing

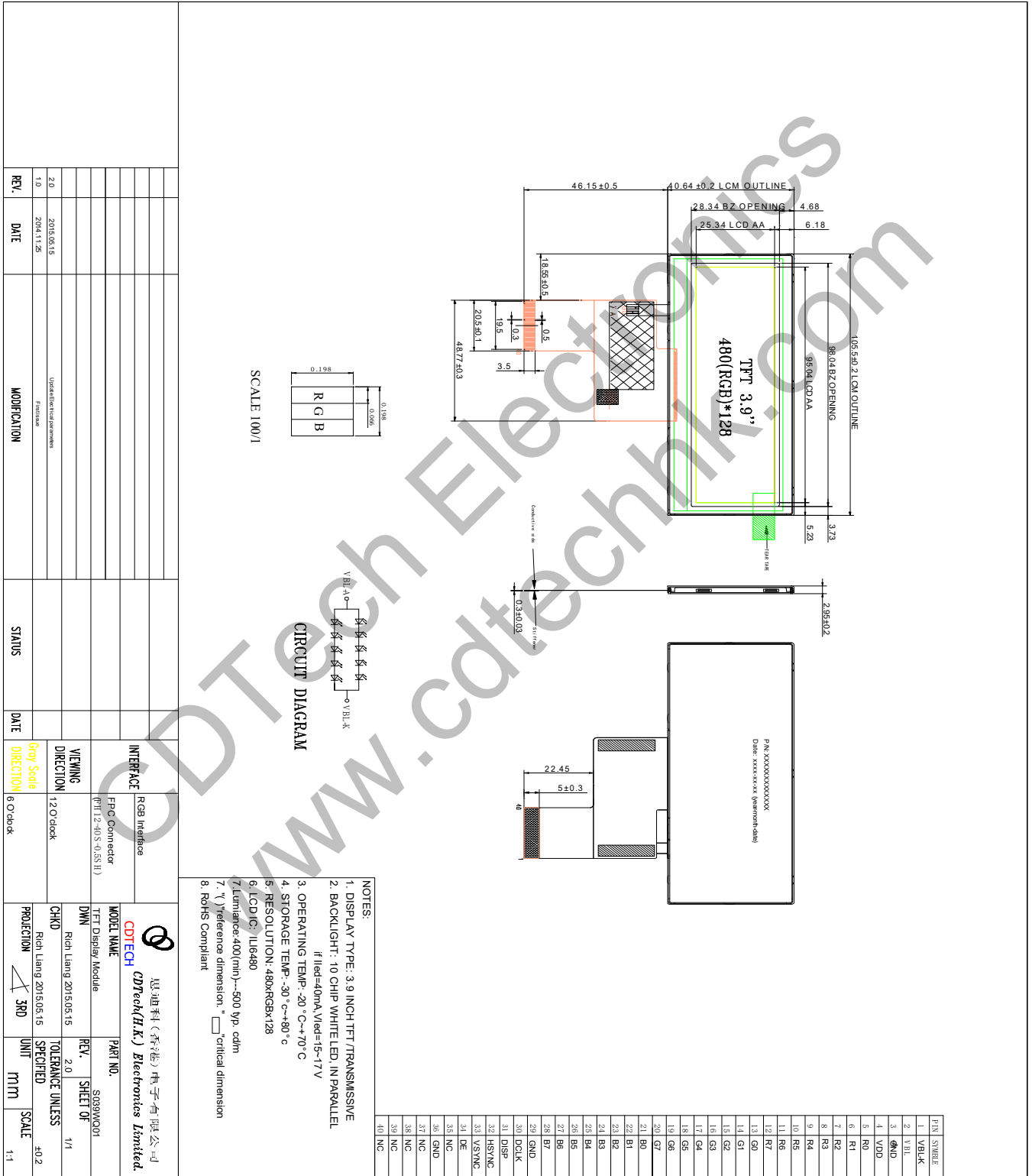



S039WQ01 V5.0

CDTech(H.K.)Electronics Limited

10 Packing

TBD

CDTech Electronics
www.cdtechhk.com

11 Precautions For Use of LCD modules

11.1 Handling Precautions

11.1.1. The display panel is made of glass. Do not subject it to a mechanical shock by dropping it from a high place, etc.

11.1.2. If the display panel is damaged and the liquid crystal substance inside it leaks out, be sure not to get any in your mouth, if the substance comes into contact with your skin or clothes, promptly wash it off using soap and water.

11.1.3. Do not apply excessive force to the display surface or the adjoining areas since this may cause the color tone to vary.

11.1.4. The polarizer covering the display surface of the LCD module is soft and easily scratched. Handle this polarizer carefully.

11.1.5. If the display surface is contaminated, breathe on the surface and gently wipe it with a soft dry cloth. If still not completely clear, moisten cloth with one of the following solvents:

- Isopropyl alcohol
- Ethyl alcohol

Solvents other than those mentioned above may damage the polarizer. Especially, do not use the following:

- Water
- Ketone
- Aromatic solvents

11.1.6. Do not attempt to disassemble the LCD Module.

11.1.7. If the logic circuit power is off, do not apply the input signals.

11.1.8. To prevent destruction of the elements by static electricity, be careful to maintain an optimum work environment.

11.1.8.1. Be sure to ground the body when handling the LCD Modules.

11.1.8.2. Tools required for assembly, such as soldering irons, must be properly ground.

11.1.8.3. To reduce the amount of static electricity generated, do not conduct assembly and other work under dry conditions.

11.1.8.4. The LCD Module is coated with a film to protect the display surface. Be care when peeling off this protective film since static electricity may be generated.

11.2 Storage Precautions

11.2.1. When storing the LCD modules, avoid exposure to direct sunlight or to the light of fluorescent lamps.

11.2.2. The LCD modules should be stored under the storage temperature range. If the LCD modules will be stored for a long time, the recommend condition is:

Temperature : 0°C ~ 40°C Relatively humidity: ≤80%

11.2.3. The LCD modules should be stored in the room without acid, alkali and harmful gas.

11.3 Transportation Precautions

The LCD modules should be no falling and violent shocking during transportation, and also should avoid excessive press, water, damp and sunshine.