

REV.	ECN. NO.	NAME	DATE

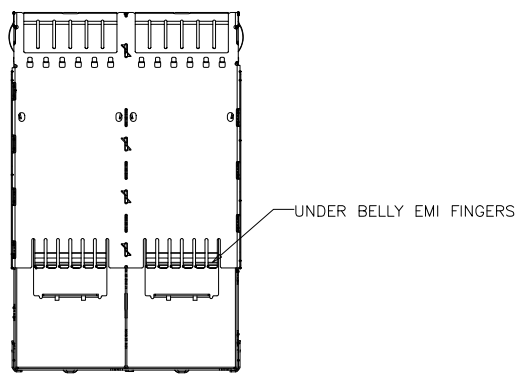
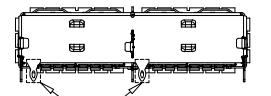
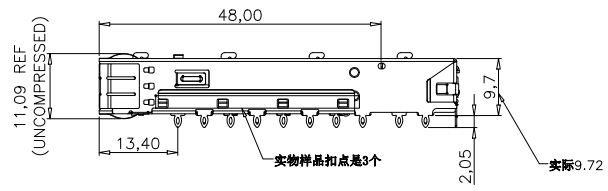
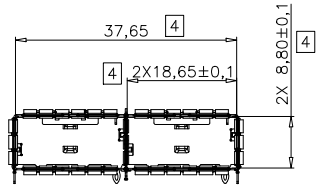
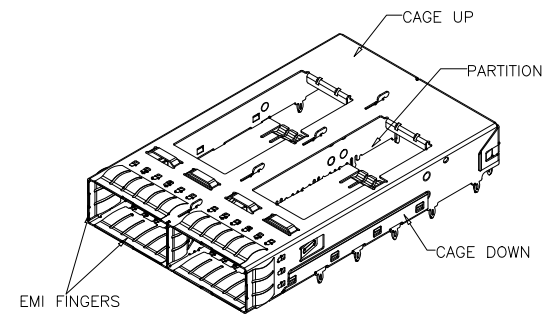
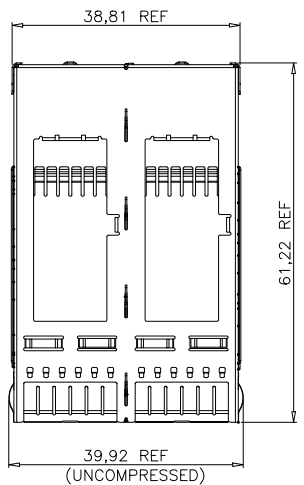

REAR LEGS ARE OPTIONAL:
1 LEG OR NO LEG

- MATERIALS:
CAGE UP: STAINLESS STEEL, 0.25 THICKNESS
CAGE DOWN: STAINLESS STEEL, 0.25 THICKNESS
PARTITION: STAINLESS STEEL
EMI FINGERS: STAINLESS STEEL
HEATSINK: ALUMINUM
HEATSINK CLIP: STAINLESS STEEL
LIGHT PIPE MATERIAL: CLEAR POLYCARBONATE
CAP: THERMOPLASTIC 94V-0, BLACK
- SURFACE FINISH:
BODY CAGE: CLEANING
EMI SPRING FINISH: CLEANING AND HOLE SEALING
HEATSINK FINISH: BLACK ANODIZED
HEATSINK CLIP FINISH: CLEANING
- MATE WITH QSFP MSA COMPATIBLE TRANSCEIVER.
- INSIDE SURFACE OF CASSET WHEN FULLY COMPRESSED.
- REFERENCE DOCUMENTS:
PRODUCT SPECIFICATION: SFF-8663
- THIS PRODUCT COMPLY TO ROHS DIRECTIVE 2011/65/EU.

S128 X X X 1 X
1 2 3 4

- REAR LEGS:
0=W/O REAR LEG
1=W/ 1 REAR LEG
- LIGHT PIPE & CAP OPTION:
0=W/O Light Pipe, W/O CAP
1=W/ Light Pipe, W/O CAP
2=W/ Light Pipe, W/ CAP
- LIGHT PIPE DIM "A" & PLATING OPTION:
0=W/O Light Pipe
1=DIM A=10.7mm, W/O Silver Color plating
2=DIM "A"=9.7mm, W/O Silver Color plating
3=DIM A=10.7mm, W/Silver Color plating
4=DIM "A"=9.7mm, W/Silver Color plating
- PROCESS OPTION:
0=W/O Heatsink, Open Top
1=W/PCI(Heatsink 4.2mm)
2=W/SAN(Heatsink 6.5mm)
3=W/Networking(Heatsink 13.5mm)

REAR LEGS OPTIONALS

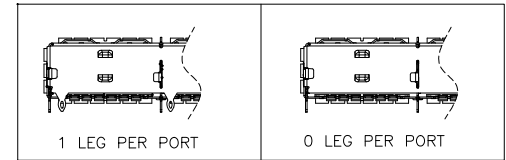

REMARK: APPLIES TO ALL CAGES IN THIS DRAWING

RoHS Compliant

TOLERANCE UNSPECIFIED		VITALCON a vital connector company		FOR YOUR VITAL CONNECTION	
.0	± 0.38			TITLE: QSFP+28G 1X2 CAGE	
.00	± 0.25	DRAWN BY:	BECKER	PART NO:	S128 X X X 1 X
.000	± 0.10	CHECKED BY:	VTA	SIZE: A4	UNIT:mm
ANGLE	± 3.00°	APPROVED BY:	QPF	PROJECTION	
MANUFACTURING COPY				SHEET:10F7	REV: A
				FCN: A4	http://www.vitalconn.com

WITH HATSINK, WITH QUAD LIGHT PIPE AND CAP

LIGHT PIPE WITHOUT SILVER COLOR PLATING

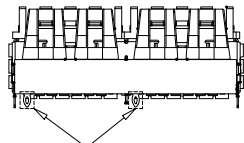
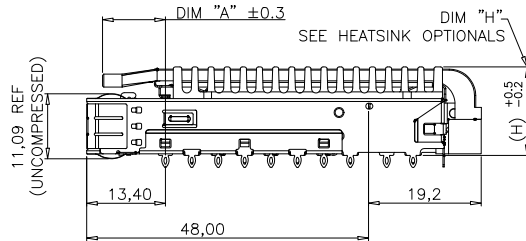
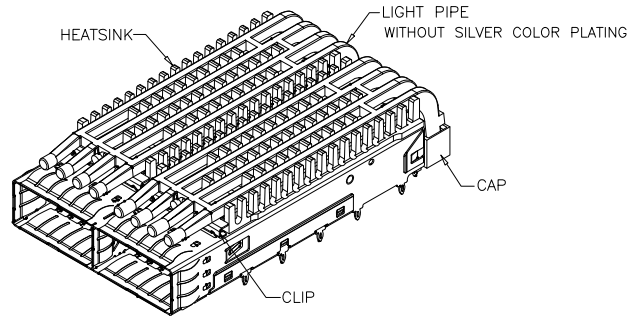
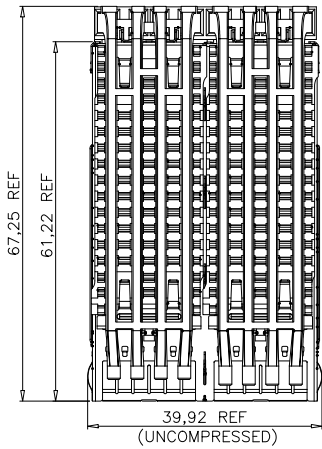

REAR LEGS ARE OPTIONAL:
1 LEG OR NO LEG

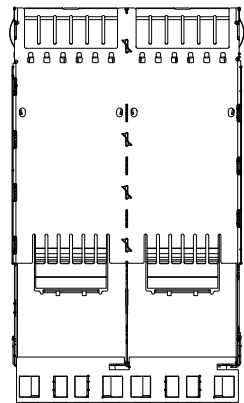

HEATSINK OPTIONALS

OVERALL HEATSINK HEIGHT	DIM "H"	
	WITH MODULE INSERTED	WITHOUT MODULE INSERTED
PCI HS (4.2mm)	13.7 REF	12.8 REF
SAN HS (6.5mm)	16.0 REF	15.1 REF
NET HS (13.5mm)	23.0 REF	22.1 REF

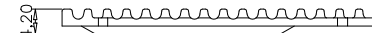

PCI HEATSINK



SAN HEATSINK

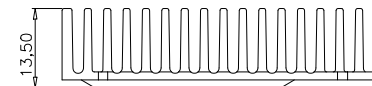

NET HEATSINK

PART NUMBER SELECTION

10.7	NET(13.5mm)	1	W/ CAP
9.7	NET(13.5mm)	1	W/ CAP
10.7	SAN(6.5mm)	1	W/ CAP
9.7	SAN(6.5mm)	1	W/ CAP
10.7	PCI(4.2mm)	1	W/ CAP
9.7	PCI(4.2mm)	1	W/ CAP
10.7	NET(13.5mm)	0	W/ CAP
9.7	NET(13.5mm)	0	W/ CAP
10.7	SAN(6.5mm)	0	W/ CAP
9.7	SAN(6.5mm)	0	W/ CAP
10.7	PCI(4.2mm)	0	W/ CAP
9.7	PCI(4.2mm)	0	W/ CAP
DIM A	HEAT SINK	REAR LEGS OPTIONALS	CAP OPTIONALS

REV.	ECN. NO.	NAME	DATE

RoHS Compliant

TOLERANCE UNSPECIFIED				FOR YOUR VITAL CONNECTION	
.0	± 0.38				
.00	± 0.25	TITLE: QSFP+28G 1X2 CAGE			
.000	± 0.10	DRAWN BY:	BECKER	PART NO:	S128 X X X 1 X
ANGLE	± 3.00°	CHECKED BY:	VTA	SIZE: A4	UNIT:mm
MANUFACTURING COPY		APPROVED BY:	QPF	PROJECTION	SHEET:20F7
					REV: A
					FCN: A4
					http://www.vitalconn.com

REV.	ECN. NO.	NAME	DATE

WITH HATSINK, WITH QUAD LIGHT PIPE AND CAP
LIGHT PIPE WITH SILVER COLOR PLATING

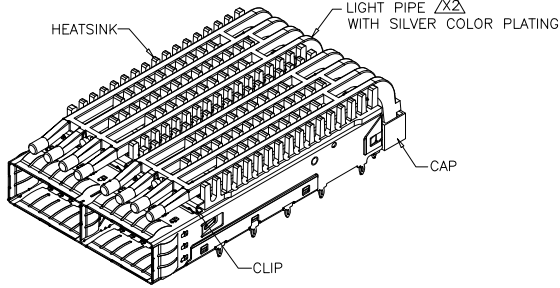
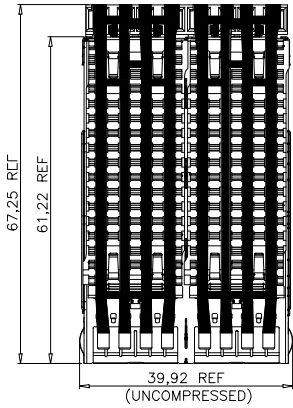

HEATSINK OPTIONS

OVERALL HEIGHT	HEATSINK	DIM "H"	
		WITH MODULE INSERTED	WITHOUT MODULE INSERTED
PCI HS (4.2mm)		13.7 REF	12.8 REF
SAN HS (6.5mm)		16.0 REF	15.1 REF
NET HS (13.5mm)		23.0 REF	22.1 REF

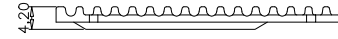

PCI HEATSINK

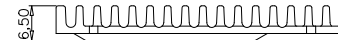

SAN HEATSINK

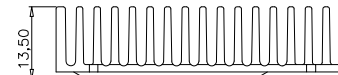

NET HEATSINK

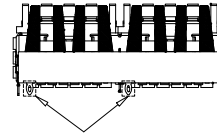
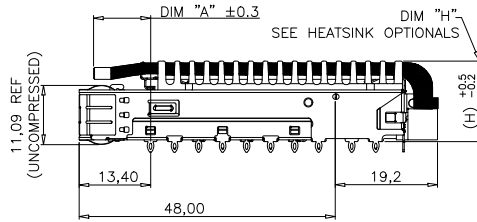

REAR LEGS ARE OPTIONAL:
1 LEG OR NO LEG

PART NUMBER SELECTION

10.7	NET(13.5mm)	1	W/ CAP	
9.7	NET(13.5mm)	1	W/ CAP	
10.7	SAN(6.5mm)	1	W/ CAP	
9.7	SAN(6.5mm)	1	W/ CAP	
10.7	PCI(4.2mm)	1	W/ CAP	
9.7	PCI(4.2mm)	1	W/ CAP	
10.7	NET(13.5mm)	0	W/ CAP	
9.7	NET(13.5mm)	0	W/ CAP	
10.7	SAN(6.5mm)	0	W/ CAP	
9.7	SAN(6.5mm)	0	W/ CAP	
10.7	PCI(4.2mm)	0	W/ CAP	
9.7	PCI(4.2mm)	0	W/ CAP	
DIM A	HEAT SINK	REAR LEGS OPTIONALS	CAP OPTIONALS	

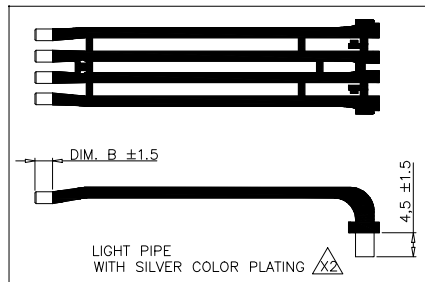
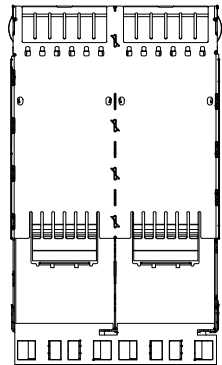
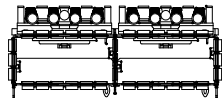

RoHS Compliant

TOLERANCE UNSPECIFIED		VITALCON a vital connector company		FOR YOUR VITAL CONNECTION	
.0	± 0.38	TITLE: QSFP+28G 1X2 CAGE			
.00	± 0.25				
.000	± 0.10				
ANGLE	± 3.00°				
MANUFACTURING COPY					
DRAWN BY:	BECKER	PART NO:	S128 X X X 1 X		REV: A
CHECKED BY:	VTA	SIZE: A4	UNIT:mm	SHEET:30F7	FCN: A4
APPROVED BY:	QPF	PROJECTION			http://www.vitalconn.com

REV.	ECN. NO.	NAME	DATE

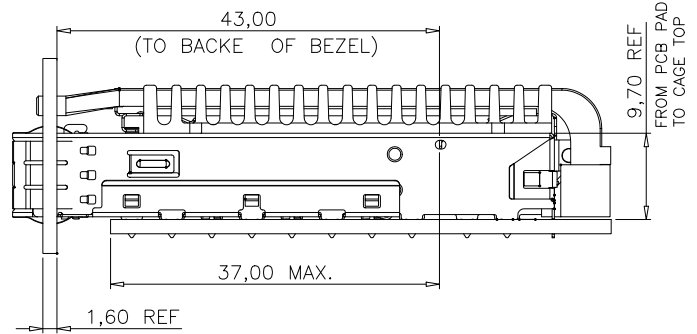
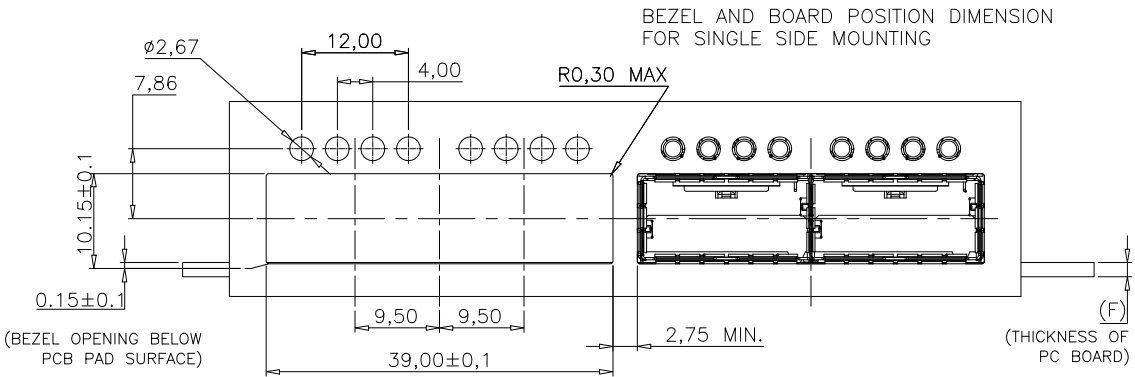

BEZEL AND BOARD POSITION DIMENSION FOR BELLY TO BELLY MOUNTING

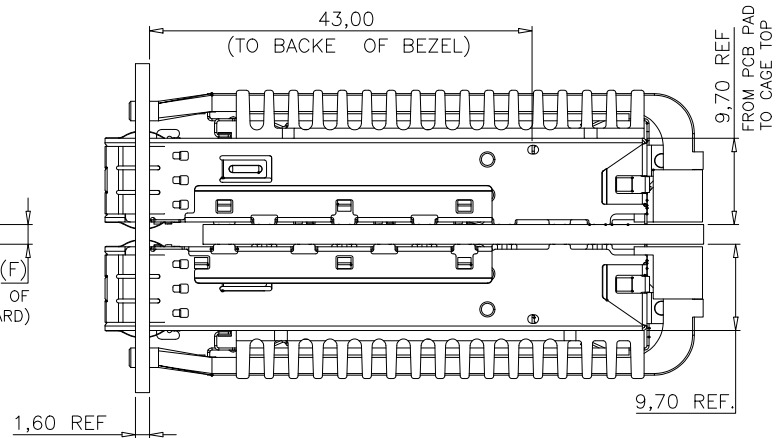
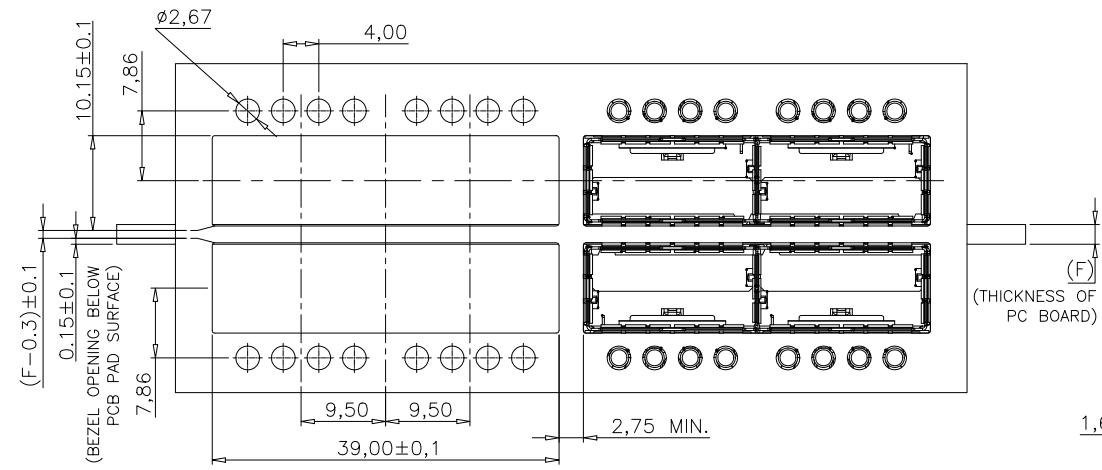

- NOTES:
- THE NORMAL THICKNESS OF CUSTOMER SUPPLIED PC BOARD.(DIM. "F")
SINGLE SIDED PC BOARD THICKNESS: 1.60mm MIN.
BELLY TO BELLY PC BOARD THICKNESS: 3.0mm MIN.
 - GENERAL TOLERANCE: ± 0.05 .

RoHS Compliant

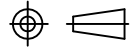
TOLERANCE UNSPECIFIED		 VITALCON a vital connector company		FOR YOUR VITAL CONNECTION	
.0	± 0.38			TITLE: QSFP+28G 1X2 CAGE	
.00	± 0.25	DRAWN BY: BECKER	PART NO: S128 X X X 1 X	REV: A	
.000	± 0.10	CHECKED BY: VTA	SIZE: A4	UNIT:mm	SHEET:40F7 FCN: A4
ANGLE	$\pm 3.00^\circ$	APPROVED BY: QPF	PROJECTION	 http://www.vitalconn.com	
MANUFACTURING COPY					

REV.	ECN. NO.	NAME	DATE

		THE DIMENSION FOR MATING BEZEL (UNIT: mm)						
CODE	L/P APPEARANCE	L/P CUT-OUT	L/P PITCH (FRONT)	L/P PITCH (REAR)	L/P HEIGHT	BEZEL THICKNESS	LED HEIGHT	REMARK
0	NO L/P	/	/	/	/	/	/	WITHOUT LIGHT PIPE
A	ROUND	ø2.67	4.00(Equal)	1,4=15.75 2,3=3.40	7.86	1.60	0.8~1.1	APPLIES TO QUAD L/P
		①	②	③	④	⑤	⑥	

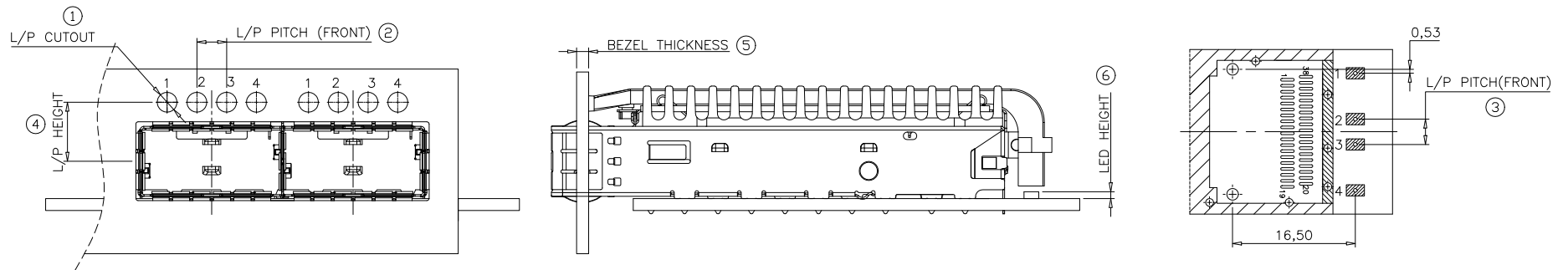

RoHS Compliant

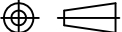
TOLERANCE UNSPECIFIED		 VITALCON a vital connector company		FOR YOUR VITAL CONNECTION	
.0	± 0.38			TITLE: QSFP+28G 1X2 CAGE	
.00	± 0.25	DRAWN BY: BECKER		PART NO: S128 X X X 1 X	
.000	± 0.10	CHECKED BY: VTA		SIZE: A4	
ANGLE	± 3.00°	APPROVED BY: QPF		UNIT:mm	
MANUFACTURING COPY		PROJECTION		SHEET:50F7	
				FCN: A4	
				 http://www.vitalconn.com	

REV.	ECN. NO.	NAME	DATE

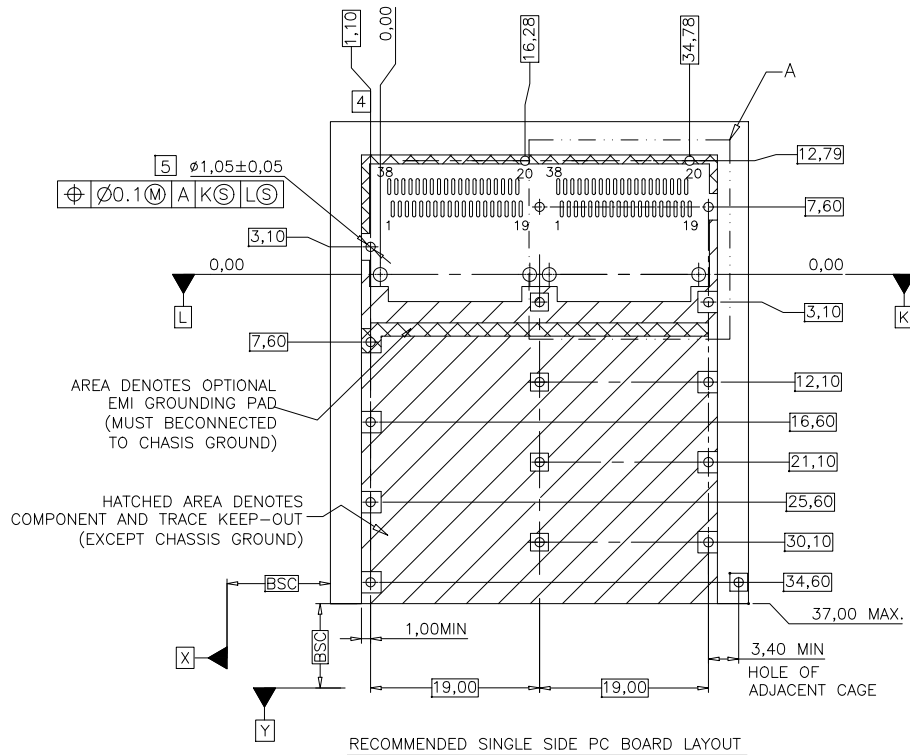

NOTES:

- 1. DATUM X & Y ARE ESTABLISHED BY THE CUSTOMER'S FIDUCIAL
- 2. DATUM A IS THE TOP SURFACE OF THE HOST BOARD
- 3. LOCATION OF THE EDGE OF PCB IS APPLICATION SPECIFIC
- 4. BASELINE FOR THESE DIMENSIONS IS THE CENTER OF COMPLIANT PIN HOLE.
- 5. FINISHED HOLE SIZE
- 6. UNPLATED THRU HOLE.
- 7. REFER TO SFF8662 FOR CONNECTOR FOOTING DIMENSIONS

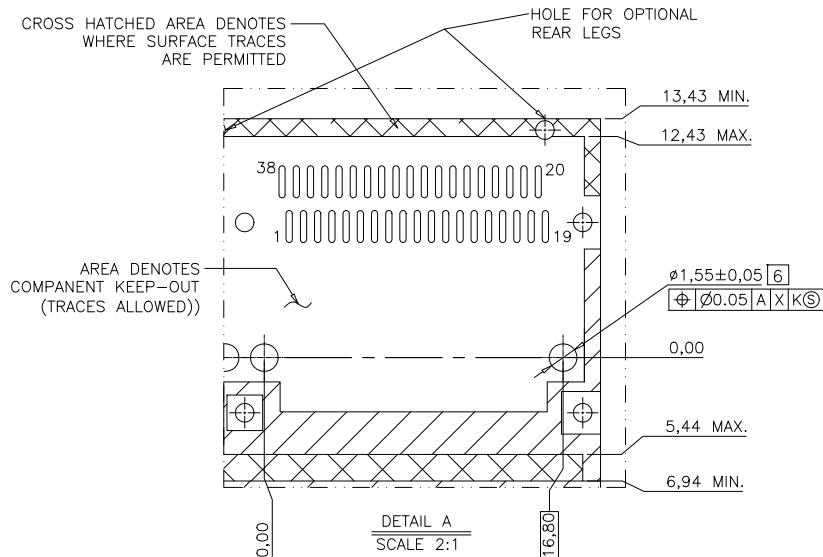

FOR CAGE ASSEMBLIES WITH LIGHT PIPES

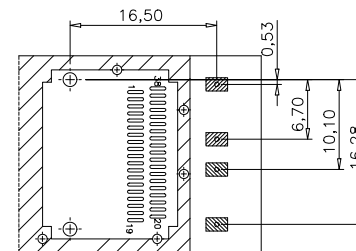

RoHS Compliant

TOLERANCE UNSPECIFIED		VITALCON a vital connector company		FOR YOUR VITAL CONNECTION	
.0	± 0.38			TITLE: QSFP+28G 1X2 CAGE	
.00	± 0.25	DRAWN BY:	BECKER	PART NO:	S128 X X X 1 X
.000	± 0.10	CHECKED BY:	VTA	SIZE: A4	UNIT:mm
ANGLE	± 3.00°	APPROVED BY:	QPF	PROJECTION	⊕
MANUFACTURING COPY		REV: A		SHEET:6OF7	
				FCN: A4	
				http://www.vitalconn.com	

REV.	ECN. NO.	NAME	DATE

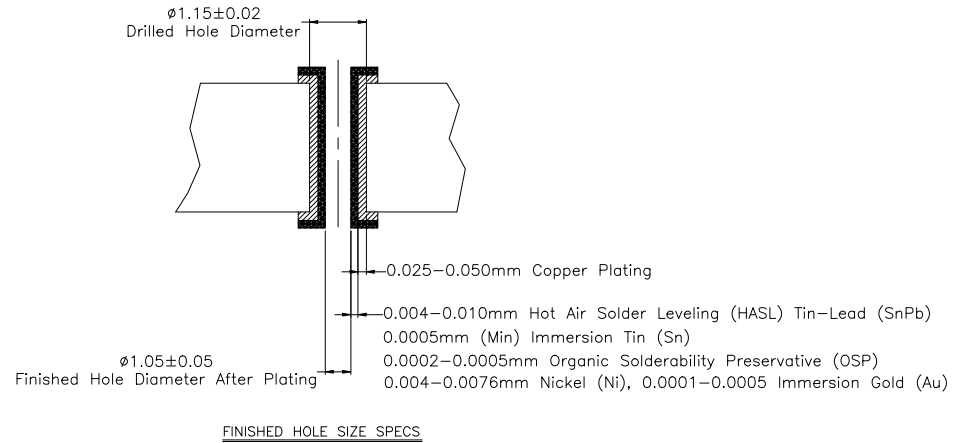
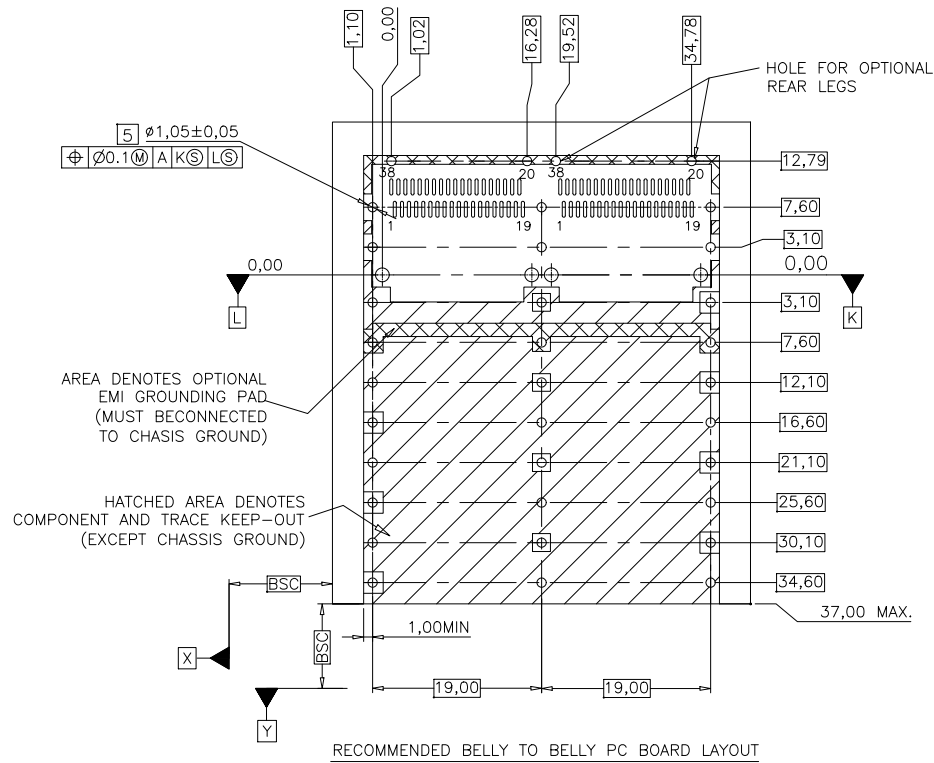

RoHS Compliant

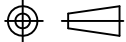
TOLERANCE UNSPECIFIED		 VITALCON a vital connector company		FOR YOUR VITAL CONNECTION	
.0	± 0.38			TITLE: QSFP+28G 1X2 CAGE	
.00	± 0.25	DRAWN BY: BECKER	PART NO: S128 X X X 1 X	REV: A	
.000	± 0.10	CHECKED BY: VTA	SIZE: A4	UNIT:mm	SHEET:70F7
ANGLE	± 3.00°	APPROVED BY: QPF	PROJECTION	 http://www.vitalconn.com	
MANUFACTURING COPY					