

Actual Size = 5 x 7mm



#### Product Features

- 1.8V CMOS compatible logic levels
- Pin-compatible with standard 5x7mm packages
- Designed for standard reflow and washing techniques
- Low power standby mode
- Pb-free and RoHS/Green compliant

#### Product Description

The S1612 Series is a 1.8V crystal clock oscillator using less than 20mW. The output clock signal, generated internally with a non-PLL oscillator design, is compatible with JESD8-7 logic levels. The device, available on tape and reel, is contained in a 5x7mm surface-mount ceramic package.

#### Applications

The S1612 Series is an ideal reference clock for applications requiring low jitter and low power, including:

- Portable Electronics
- Server & Storage platforms
- 802.11a/b/g WiFi



#### Packaging Outline

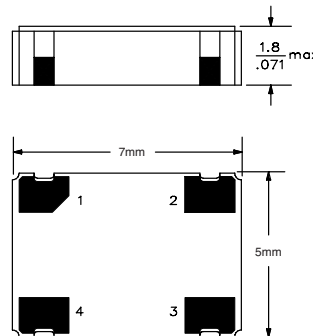

#### Pin Functions

Pin	Function
1	OE Function
2	Ground
3	Clock Output
4	V <sub>DD</sub>

#### Common Frequencies

Contact SaRonix for additional frequencies

1.5440 MHz	20.0000 MHz	38.8800 MHz
2.0480 MHz	22.0000 MHz	40.0000 MHz
3.6864 MHz	24.5760 MHz	44.0000 MHz
8.0000 MHz	25.0000 MHz	44.7360 MHz
10.0000 MHz	32.0000 MHz	48.0000 MHz
14.3181 MHz	32.7680 MHz	50.0000 MHz
16.0000 MHz	33.0000 MHz	60.0000 MHz
16.3840 MHz	34.3680 MHz	66.0000 MHz
18.4320 MHz	35.3280 MHz	66.6667 MHz
19.4400 MHz		

#### Ordering Information

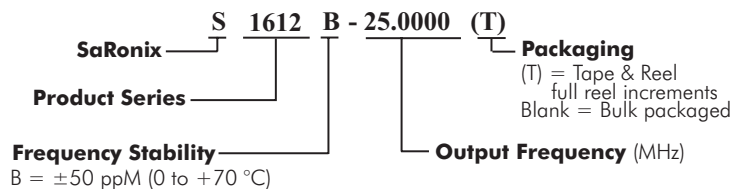

**Electrical Performance**

Parameter	Min.	Typ.	Max.	Units	Notes
Output frequency	1.544		70	MHz	As specified
Supply voltage	+1.71	+1.8	+1.89	V	
Supply current, output enabled			4	mA	<36 MHz
			7		36 to 50 MHz
			10		>50 to 70 MHz
Supply current, standby mode			10	μA	1.544 to <36 MHz
			100	μA	36 to 70 MHz
Frequency stability			±50	ppM	See Note 1 below
Operating temperature	0		+70	°C	As specified
Output logic 0, VOL			10% V <sub>DD</sub>	V	
Output logic 1, VOH	90% V <sub>DD</sub>			V	
Output load	15 pF (max)				
Duty cycle	45		55	%	measured 50%V <sub>DD</sub>
Rise and fall time	up to <36 MHz		4	ns	measured 20/80% of waveform
	36 to 70 MHz		2.5		

**Notes:**

- As specified. Stability includes all combinations of operating temperature, load changes, rated input (supply) voltage changes, initial calibration tolerance (25°C), aging (1 year at 25°C average effective ambient temperature), shock and vibration.

**Output Enable / Disable Function**

Parameter	Min.	Typ.	Max.	Units	Notes
Input Voltage (pin 1), Output Enable	0.7V <sub>DD</sub>			V	or open
Input voltage (pin 1), Output Disable (low power standby)			0.3V <sub>DD</sub>	V	Output is Hi-Z
Internal pullup resistance	30			kΩ	
Output disable delay			200	ns	
Output enable delay			10	ms	

Typical Frequency Stability

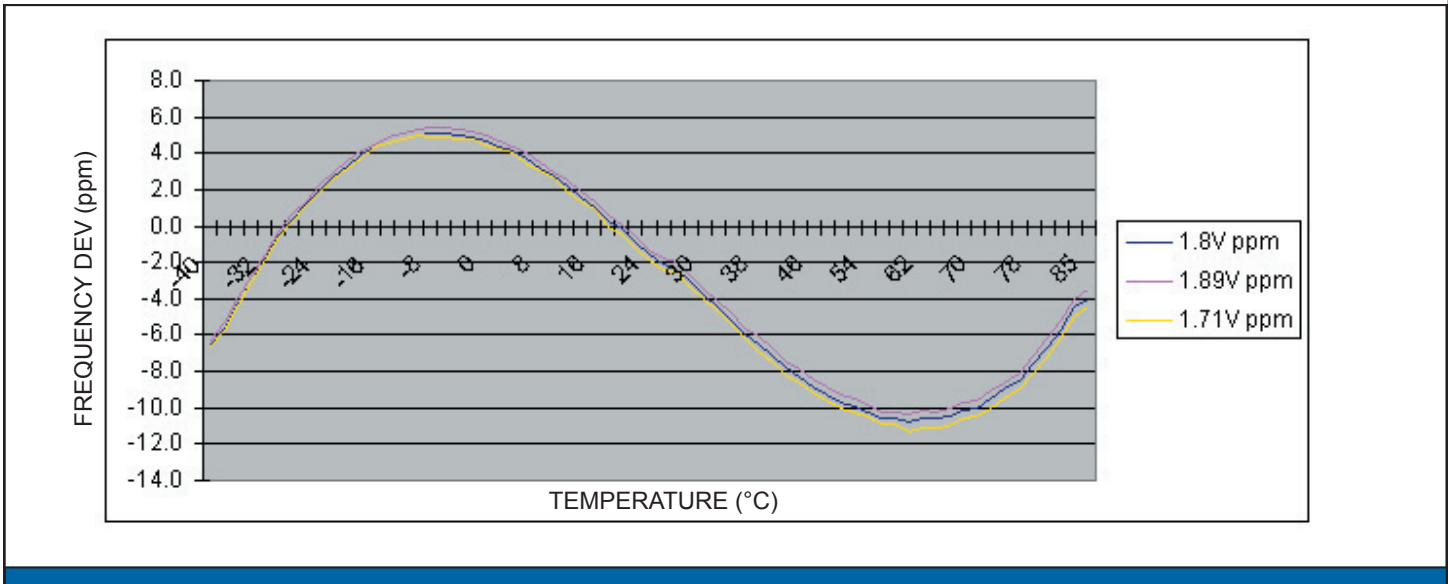

Typical Output Waveform

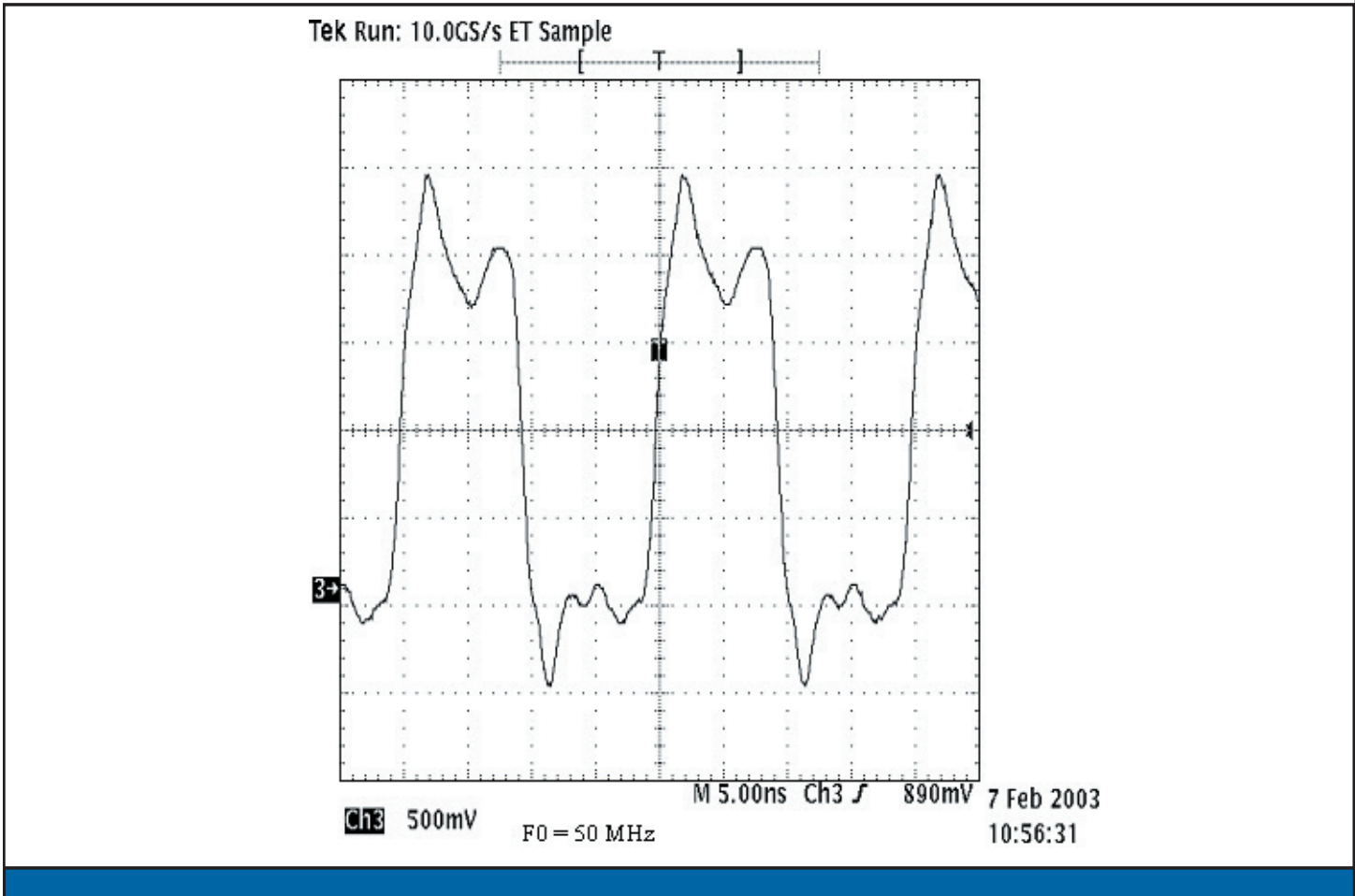

**Absolute Maximum Ratings**

Parameter	Min.	Typ.	Max.	Units	Notes
Storage temperature	-55		+125	°C	

**Test Circuit**

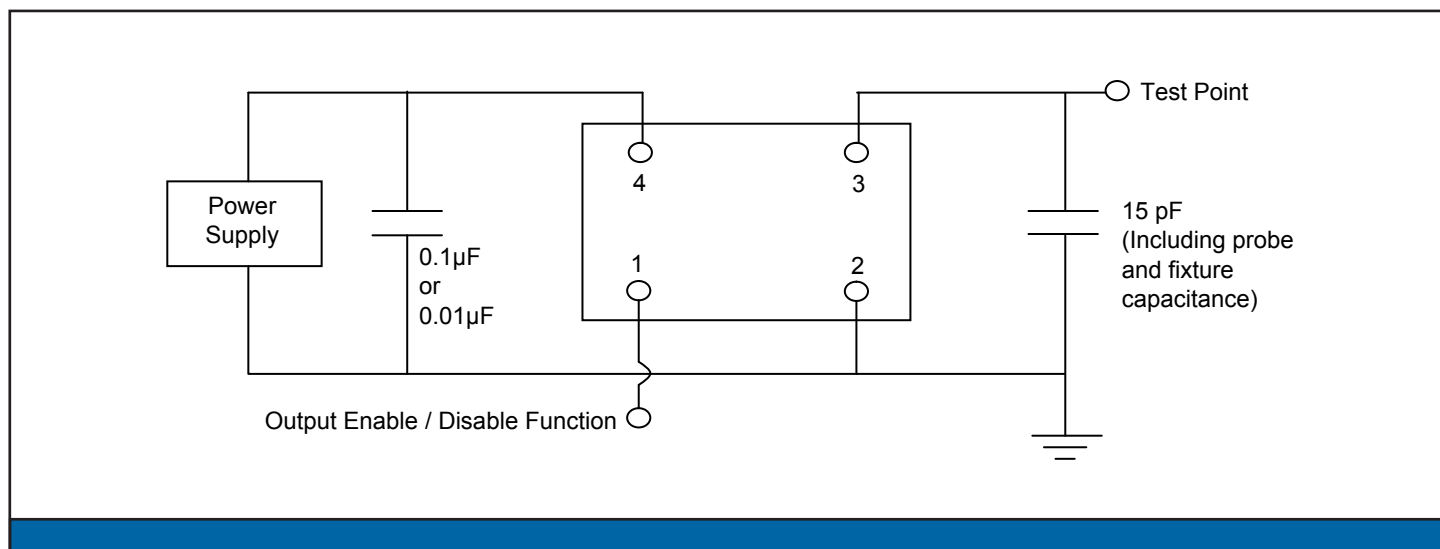

**Reliability Test Ratings**

This product is rated to meet the following test conditions:

Type	Parameter	Test Condition
Mechanical	Shock	MIL-STD-883, Method 2002, Condition B
Mechanical	Solderability	JESD22-B102-D Method 2 (Preconditioning E)
Mechanical	Terminal strength	MIL-STD-883, Method 2004, Condition D
Mechanical	Gross leak	MIL-STD-883, Method 1014, Condition C
Mechanical	Fine leak	MIL-STD-883, Method 1014, Condition A2 ( $R_1 = 2 \times 10^{-8}$ atm cc/s)
Mechanical	Solvent resistance	MIL-STD-202, Method 215
Environmental	Thermal shock	MIL-STD-883, Method 1011, Condition A
Environmental	Moisture resistance	MIL-STD-883, Method 1004
Environmental	Vibration	MIL-STD-883, Method 2007, Condition A
Environmental	Resistance to soldering heat	J-STD-020C Table 5-2 Pb-free devices (2 cycles max)

**Output Waveform**

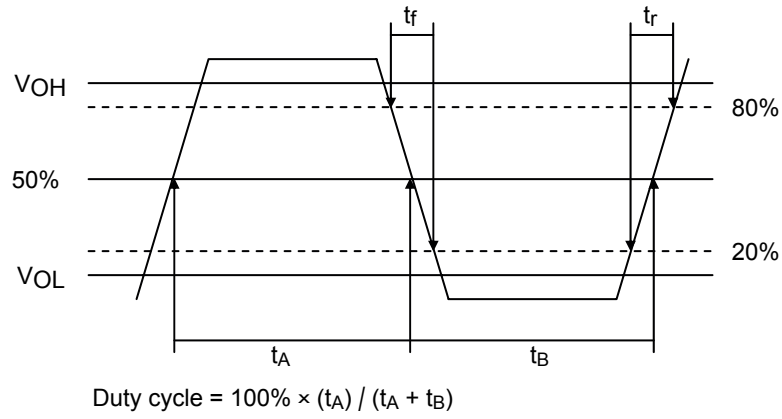

**Reflow Soldering Profile**

As per IPC/JEDEC J-STD-020C

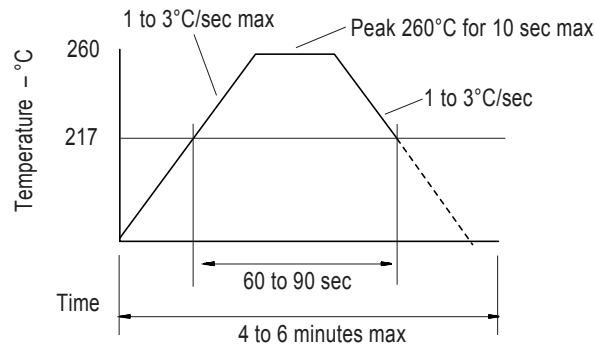

**Mechanical Drawings**

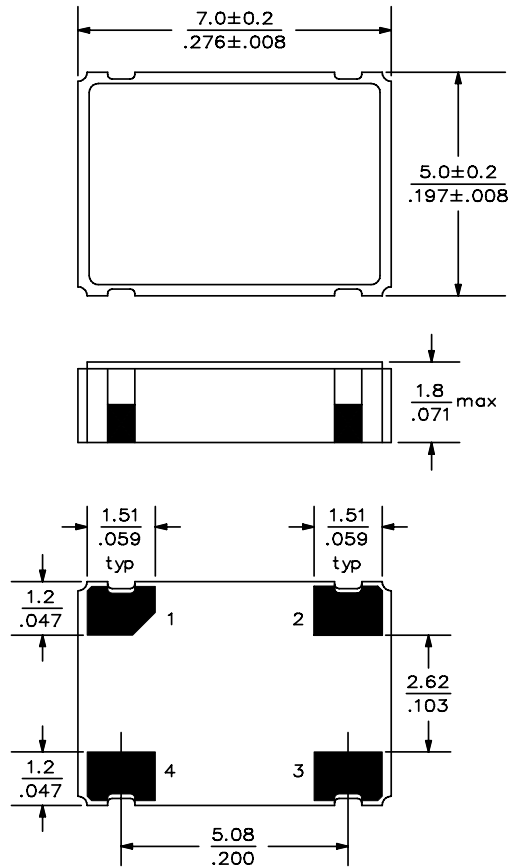

**Recommended Land Pattern\***

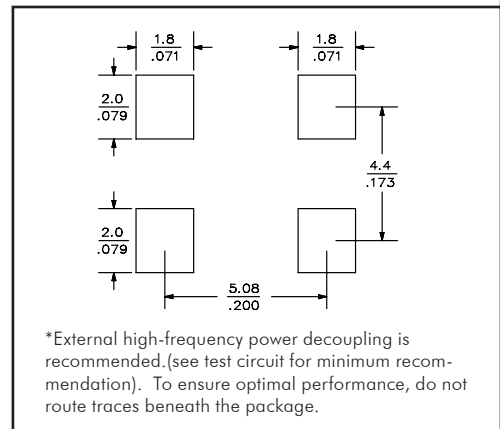

Scale: None. Dimensions are in mm/inches.

**Marking LINE 1:** S M X (SaRonix, Model, Stability code)  
**Marking LINE 2:** Frequency (Frequency code)  
**Marking LINE 3:** ● YY WW X (Pin 1, Year, Week, Origin)

\*\*Exact location of markings may vary.