



森霸传感科技
SENBA SENSING TEC.

MINI SMD 数字型热释电红外传感器 Mini SMD Digital Pyroelectric Infrared Sensors

S18-L232B-2 使用说明书

V1.0

森霸传感科技股份有限公司
Senba Sensing Technology Co., Ltd.

<http://en.nysenba.com>

I The EU RoHs Directive

All of our products in this Catalog reach ROHS standard.

The EU ROHS Directive refers to the European Union's directive 2011/65/EC on the restriction of the use of certain hazardous substances in electrical and electronic

II System Certification

Certificated by ISO14001

The company carries out various improvement measures based on the compliance with the national environmental protection law, to establish sustainable development-oriented enterprises.

Certificated by ISO 9001

The company has obtained the quality assurance of the International Organization for Standardization (ISO) - the "ISO 9001" certification.

Certificated by ISO 9001

The company has obtained the quality assurance of the International Organization for Standardization (ISO) - the "ISO 9001" certification.

III Non-commercial Use Instructions

Senba Sensing Technology Co., Ltd licensed users for non-commercial use of "S18-L232B-2 SMD Digital Pyroelectric Infrared Sensors-Instruction Manual V1.0", and provide users with product manual change and consulting services. It is must obtain written authorization and permission by Senba Sensing Technology Co., Ltd. in advance for commercially sold, copied, distributed or other commercial activities.

In addition, during use the Instruction Manual, the usage should not violate the law, endanger public safety, or harm the legitimate rights and interests of third parties. Otherwise, Senba Sensing Technology Co., Ltd. will not accept any responsibility for the user.

IV Product Name

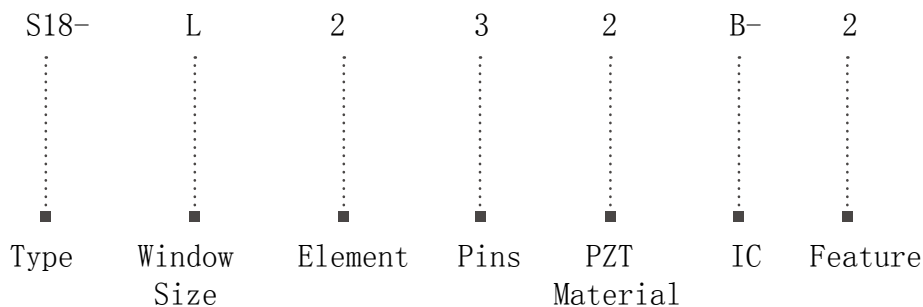

V Features & Application

Features

- Mini SMD with reflowed SMT
- Digital signal processing (DSP)
- Power adjustable, save more energy
- Built-in filter, high immunity to RFI
- Output time, sensitivity and light control non-adjustable
- Low voltage, micro power consumption



Application

- PIR motion detection
- Intruder detection
- Occupancy detection
- Motion sensor lights
- Computer monitor
- Security system

•Dimension

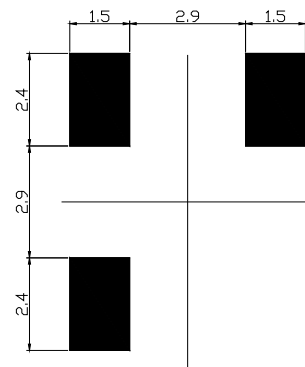
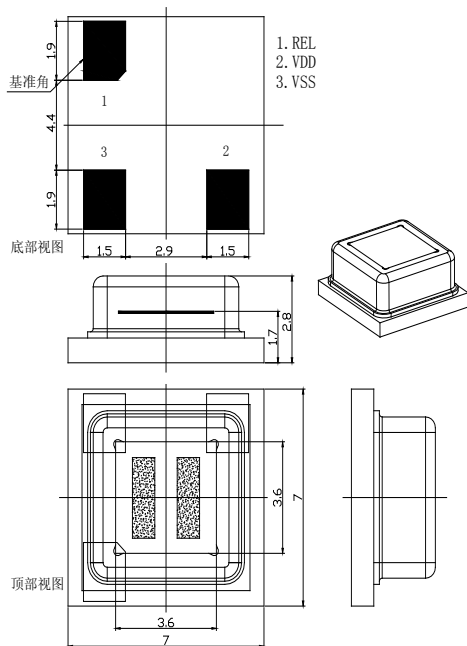

The chart of recommended welding plate

Unit: mm

•Technical Data

Electrical characteristics (Stresses beyond those listed below may cause permanent damage to the device. Exposure to absolute maximum ratings may affect the device reliability.)

Characteristics	Symbol	Min.	Max.	Unit	Remarks
Working Temperature	T_{OT}	-30	70	$^{\circ}C$	
Max. current for pin	I_{NTO}	-100	100	mA	
Viewing angle		X=110 $^{\circ}$	Y=90 $^{\circ}$	$^{\circ}$	Theoretical Angle
Storage Temperature	T_{ST}	-40	80	$^{\circ}C$	
Detection spectral response	λ	5	14	μm	

Interior Block Diagram

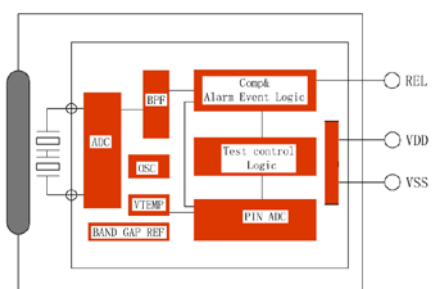

VI、Working Conditions (T=25° C, Vdd=3V, Except other requirements)

Characteristics	Symbol	Min	Type	Max.	Unit	Remarks
Supply Voltage	V _{DD}	2.2	3	3.7	V	
Working Current	I _{DD}	9	9.5	11	μA	
Sensitivity	V _{SENS}		90		μV	Non-adjustable
Output REL						
Output Low Current	I _{OL}	10			mA	VOL<1V
Output High Current	I _{OH}			-10	mA	VOH>(VDD-1V)
Low REL output locking time	T _{OL}		2		s	Non-adjustable
High REL output delay time	T _{OH}		2		s	Non-adjustable
Oscillator & Band Pass Filter (BPF)						
Band Pass Filter (BPF) Low cut-off frequency				7	Hz	
Band Pass Filter (BPF) High cut-off frequency				0.44	Hz	
Oscillator frequency on Chip	F _{CLK}			64	kHz	

VII The Output Trigger Mode

When PIR signal is above the triggered threshold, there will be a count impulse inside. And when PIR sensor receives this impulse signal, it will think this signal as the second impulse. Once the second impulse was received within 4S, the PIR sensor will alarm, meanwhile, the REL pin will be triggered.

Besides, when the PIR signal is above 5 times of the triggered threshold, only one impulse is enough to trigger REL output as below. For multiple triggers, the delay time of REL output begins from the last valid trigger.

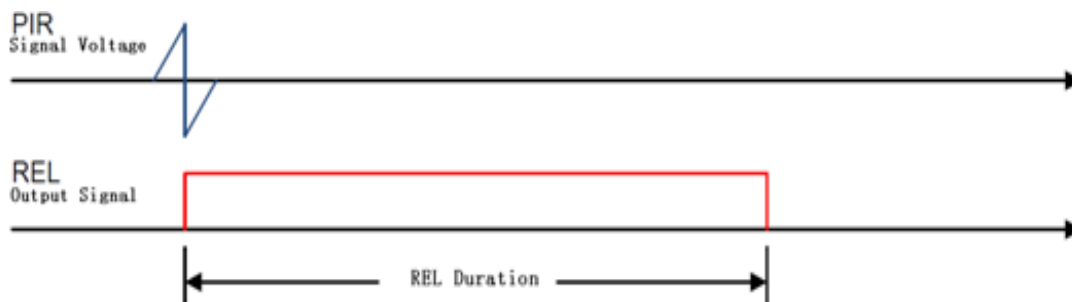

The duration of REL output in single activation

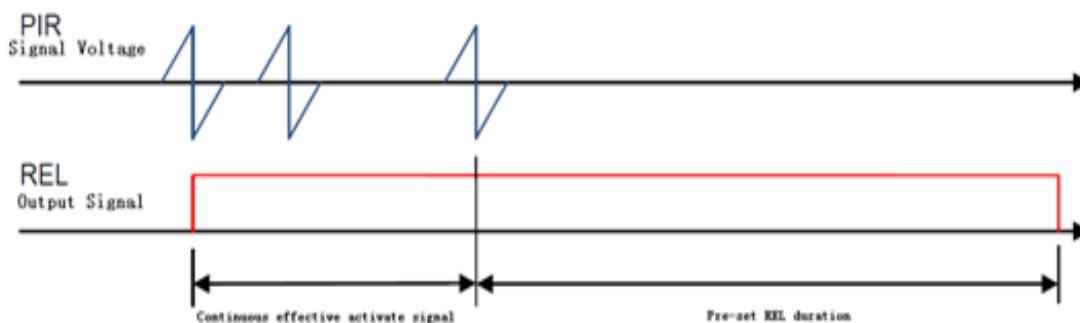

VIII Reliable Test

Test	Standard	Test Result
Salt spray test	GB/T 10125-2012	OK
High temperature test	100°C, 500 hours	OK
Low temperature test	-40°C, 500 hours	OK
Humidity	Relative humidity 95%, 500 hours	OK
Heat resistance	250°C, 10S	OK
Vibration	Frequency: 10Hz-55Hz, Time: 2 hours	OK
Fall	1m free fall	OK

IX Typical Application Circuit

MOS Application Example

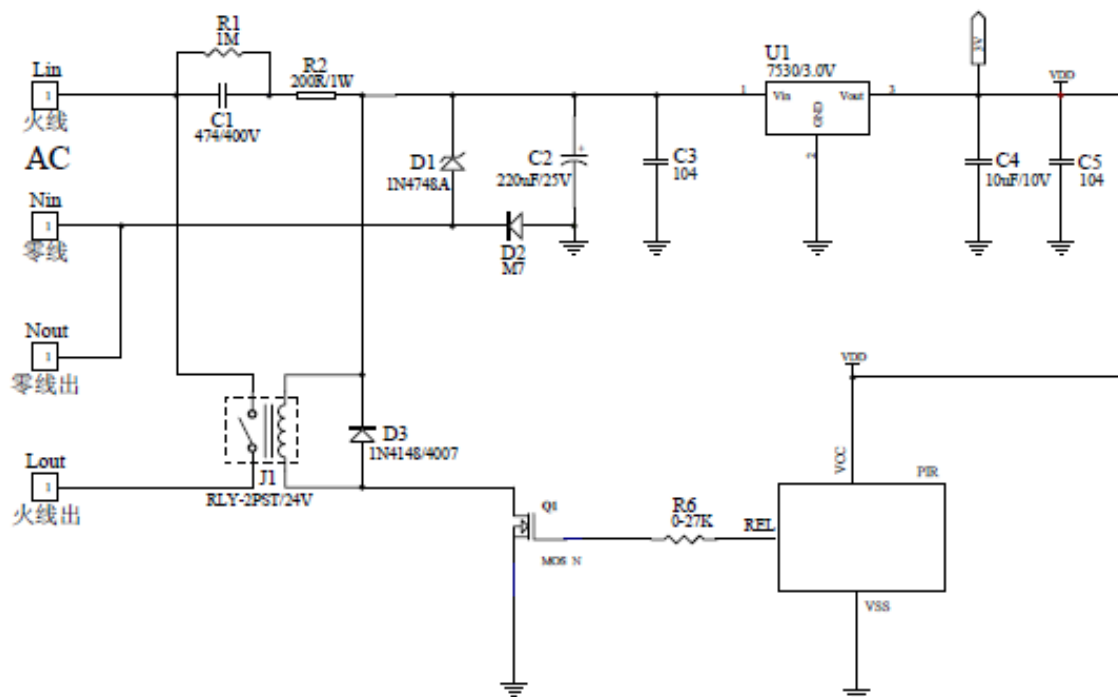

BJT Application Example

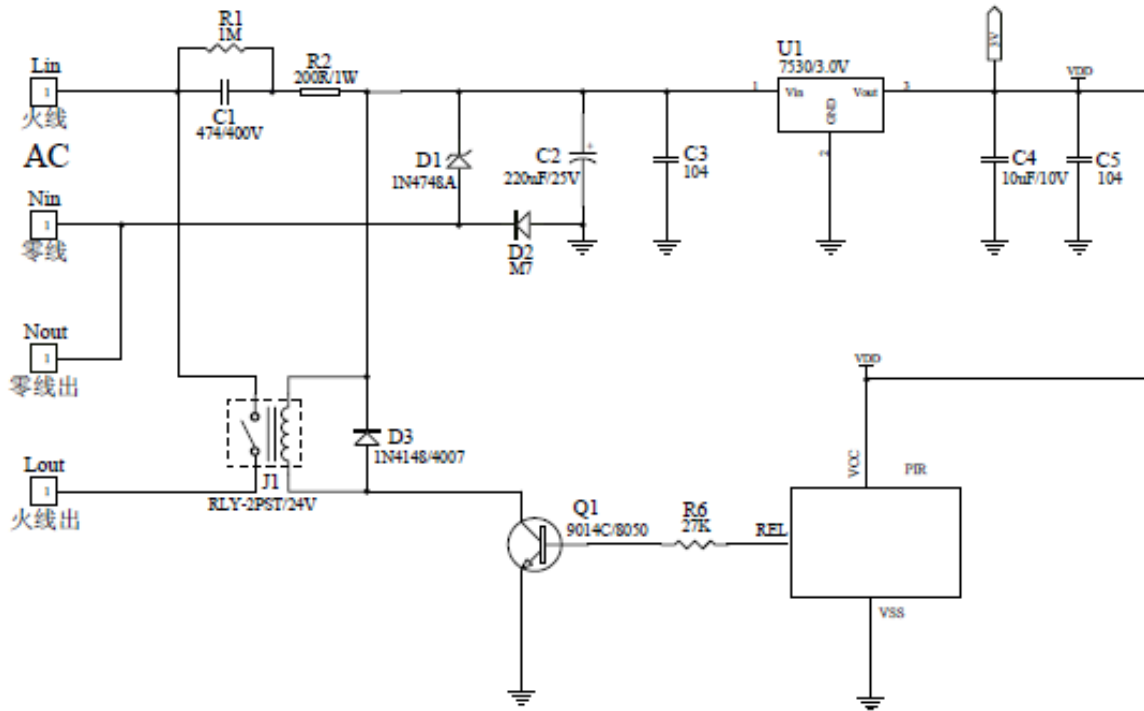

X Fresnel lens for S18-L232B-2 SMD Digital Pyroelectric Infrared Sensors

lens name: SB-F-11

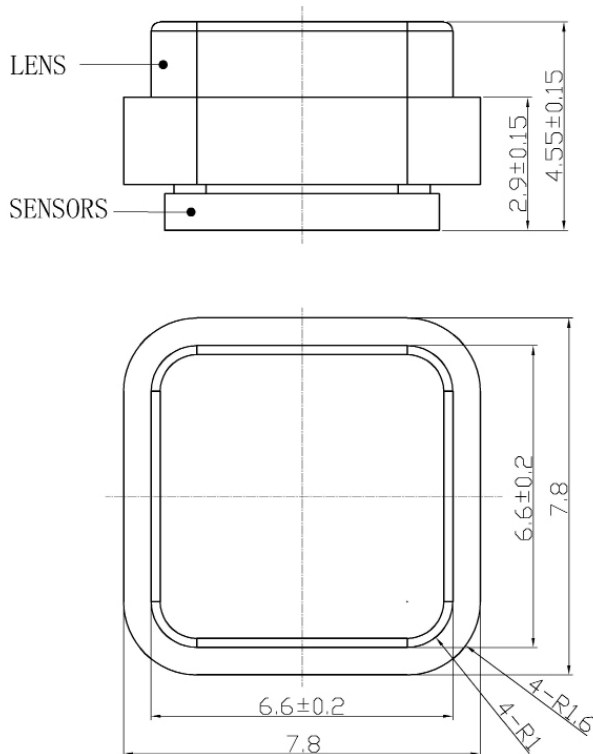

Widely used in human body sensor switches, alarms, infrared testers, smart-house appliances, and household appliances, it can provide users Fresnel lenses with different sensing angles, sensing distances and sizes.

Unit: mm

XI Field of View (use with SB-F-11)

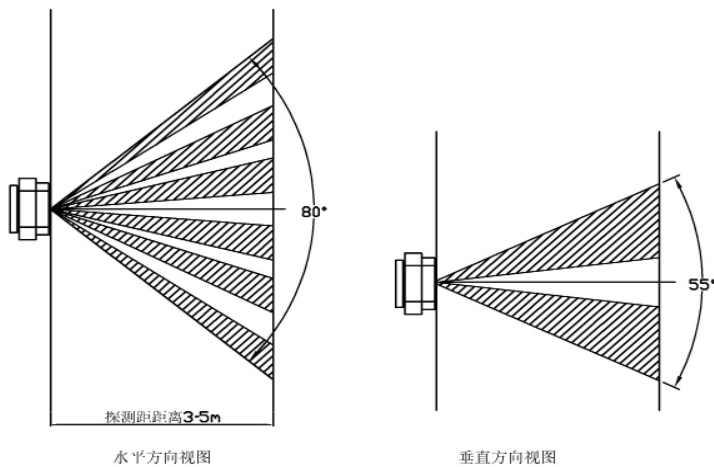

XII Package

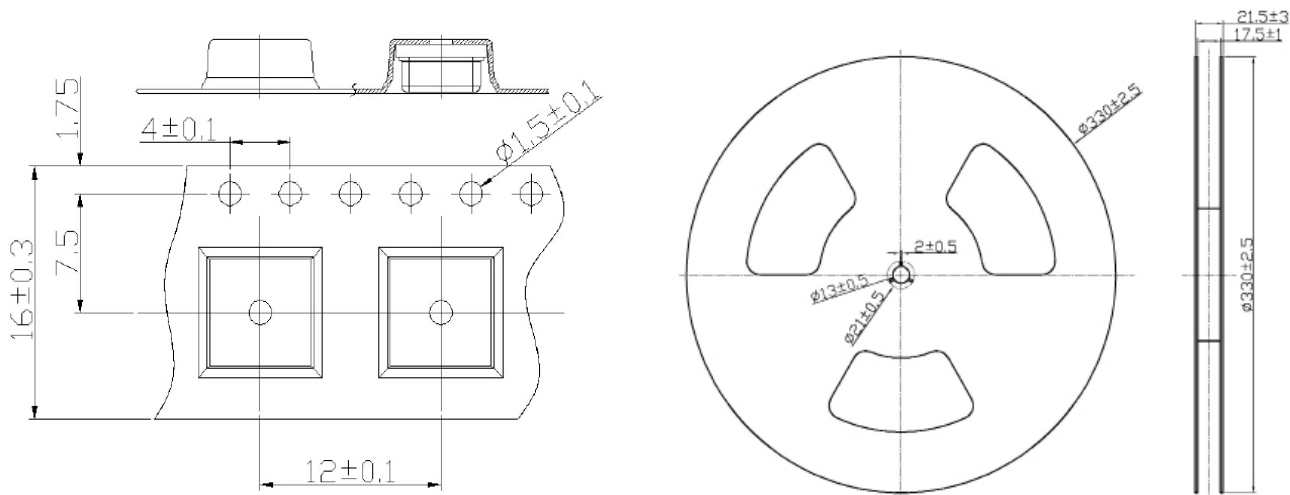

Unit: mm

Standard package: 1000pcs. According to different model types, the quantity and size of the packages will change slightly.

VIII Directions for Use

•Reflow Soldering

Sensor reflow soldering instructions

Please follow the temperature curve shown in the figure below during reflow soldering. Any reflow temperature that exceeds the figure below must be consulted with the sales engineer in advance.

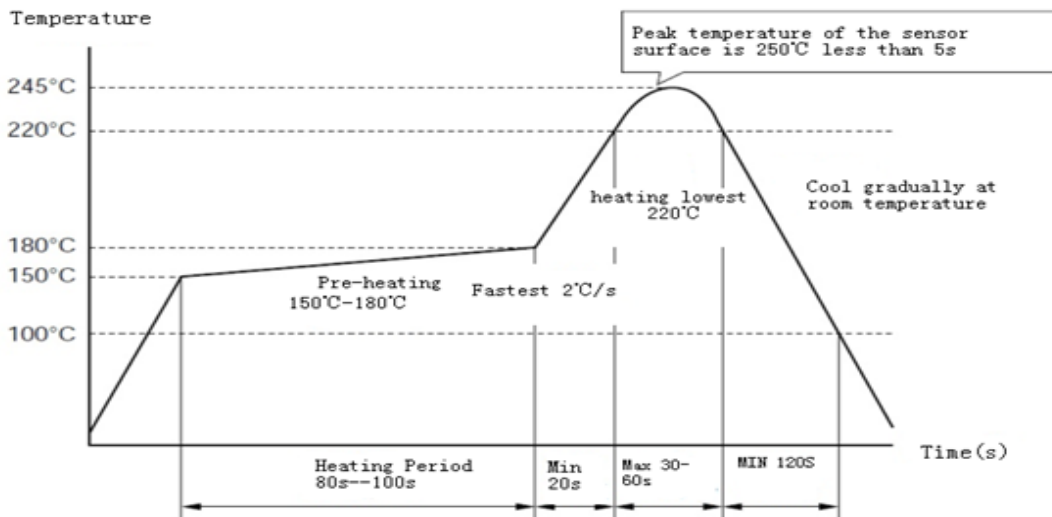

•Soldering considerations:

Do not exceed the maximum temperature curve shown above. or it may cause the sensor false performance.

Do not repeatedly reflow soldering and repeated heating repair, which will seriously affect the life and performance of the sensor, and this is not belong to the scope of product warranty.

Do not use corrosive chemical to clean the optical filter (available with absolute ethanol), which may cause the sensor to malfunction or fail.

Do not use immediately after the sensor mounting is completed. It is recommended that the cooling time should be at least 1 hour

Do not touch the terminals with metal or hand.

•Caution

1. S18-L232B-2 is a PIR sensor to detect changes of infrared ray. The sensor can only detect the heat source which is changing or moving from human body. The following items should be noticed. Please confirm the performance and reliability by practical application.

1.1 When detect the heat source besides human body

(1) Pet get into detection area.

(2) In a place exposed directly to sunlight or headlight of automobile.

(3) In a place exposed directly to blow from air-conditioner or heater which make drastic change of temperature in detection area.

1.2 The heat source is hardly detected

(1) In such a place where infrared ray is shaded by glass, propenyl, etc.

(2) The heat source does not move or high-speed move in the detection area.

2. The detection area extended

Even outside the designated detection area, there also exists broad detection area when there is a large temperature difference (above 20 °C) between environment and human body.

3. Other usage

3.1 Optical filter of sensor should not be soiled because it may cause failure or malfunction.

3.2 The lens is made by polyethylene. Please avoid stress or impact on the lens, or it will cause performance reduction and work unusually.

3.3 Electronics (above ± 200) should be avoid. Please do not touch terminal by hand.

3.4 Please solder wires with an electric iron under 350°C in 3sec by hand. Please avoid soldering by soldering tin groove.

3.5 Please avoid cleaning the sensor. The cleaning fluid may cause malfunction.

3.6 In order to avoid the interference effect of wires, the shielded wire is recommended and tries to make it short.