

**GENERAL DESCRIPTION**

**OVERVIEW**

- AM : AM RF Mixer, AM OSC, AM\_IF AMP, AM Detector, AGC, Tuning LED Driver,
- OSC Buffer, IF Buffer
- FM : RF Amp, FM RF Mixer, FM OSC, FM\_IF AMP, Quadrature Detector,
- Tuning LED Driver, OSC Buffer, IF Buffer
- MPX : PLL, Stereo Decoder, Stereo LED, MPX VCO SELF-Adjustment
- DTS : Prescaler, AM/FM Programmable Divider, AM/FM IF Counter,
- Lock Detector, LED Controller
- Microprocessor Interface

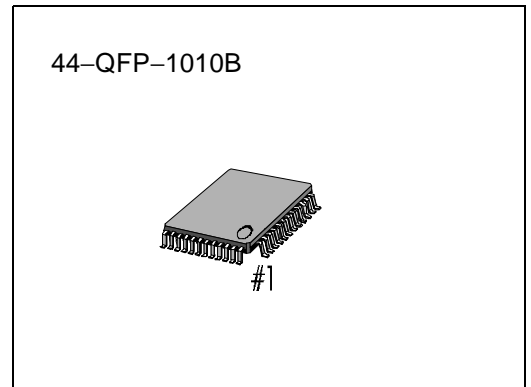

**FEATURES**

- Adopt New FCC
- AM/FM 1 Chip DTS with PLL
- MPX-VCO SELF-Adjustment
- Programmable Divider
  - FM : 10 - 160MHz <Pulse Swallow Technique>
  - AM : 2 - 40MHz <Pulse Swallow Technique>
  - 0.5 - 10MHz <Direct Division Technique>
- IF Counter : 0.4 - 12MHz <AM/FM IF Counting>
- Reference Frequency
  - Selectable Crystal (75kHz, 3.6MHz, 7.2MHz, 10.8MHz) Choice
- Package : 44 QFP

**ORDERING INFORMATION**

Device	Package	Operating Temperature
S1A0903X01-R0B0	44-QFP-1010B	-20°C - +75°C

BLOCK DIAGRAM

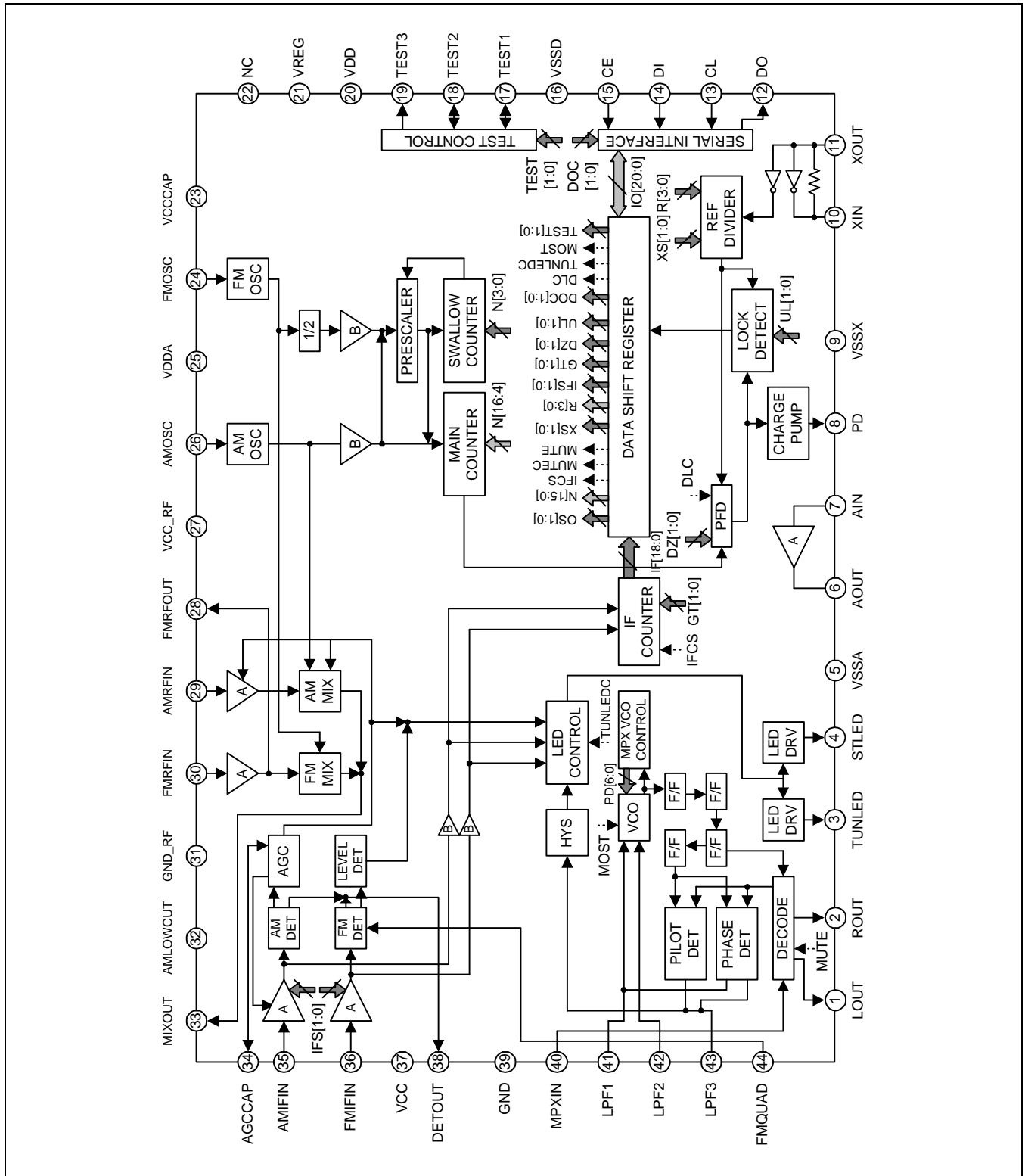

## PIN DESCRIPTION

Pin No.	Symbol	In/out	Function
1	LOUT	O	Stereo left channel output
2	ROUT	O	Stereo right channel output
3	TUNLED	O	Tuning LED
4	STLED	O	Stereo LED
5	VSSA	-	Ground
6	AOUT	O	Connections for the MOS Tr. used for the PLL active LPF.
7	AIN	I	
8	PD	O	PLL charge pump output
9	VSSX	-	Ground
10	XOUT	O	Crystal oscillator element connection. 75kHz, 3.6MHz, 7.2MHz, 10.8MHz)
11	XIN	I	
12	DO	O	Serial data output to the microprocessor
13	CL	I	Clock used for data synchronization for serial data input (DI) and serial data output (DO)
14	DI	I	Serial data input from the microprocessor
15	CE	I	Chip enable for serial I/O
16	VSSD	-	Ground
17	TEST1	I/O	Only for test
18	TEST2	I/O	-
19	TEST3	O	-
20	VDD	-	Regulator voltage input
21	VREG	-	Regulator voltage output
22	NC	-	No connection

Pin No.	Symbol	In/out	Function
23	VCCCAP	-	VCC ripple rejection cap.
24	FMOSC	I	FM oscillator input
25	VDDA	-	Power
26	AMOSC	I	AM oscillator input
27	VCC_RF	-	Power
28	FMRFOUT	O	FM RF output
29	AMRFIN	I	AM RF input
30	FMRFIN	I	FM RF input
31	GND_RF	-	Ground
32	AMLOWCUT	-	AM low cut cap.
33	MIXOUT	O	AM/FM MIX output
34	AGCCAP	-	AGC cap.
35	AMIFIN	I	AM IF input
36	FMIFIN	I	FM IF input
37	VCC	-	Power
38	DETOUT	O	AM/FM detector output
39	GND	-	Ground
40	MPXIN	-	MPX input
41	LPF1	-	Connection for the phase detector LPF
42	LPF2	-	Connection for the VCO LPF
43	LPF3	-	Connection for the pilot detector and the phase detector LPF
44	FMQUND	-	Connection for FM QUAD detector resonator

## CHARACTERISTICS

### ABSOLUTE MAXIMUM RATING

Parameter	Symbol	Rating	Unit	Remarks
Supply Voltage	VS	10	V	
Operating Temperature	Top	-20 – + 75	°C	
Storage Temperature	Tstg	-55 – + 150	°C	
Power Dissipation	Pdmax	1800	mW	

### TEMPERATURE CHARACTERISTICS

Parameter	Symbol	Condition	Rating	Unit	Remarks
Quiescent circuit current 1 (FM)	$\Delta I_{cc1}$	-20 – + 70°C	20	$\mu A/^\circ C$	
Quiescent circuit current 2 (AM)	$\Delta I_{cc2}$	-20 – + 70°C	20	$\mu A/^\circ C$	

### ELECTRO\_STATIC DISCHARGE CHARACTERISTICS

Parameter	Condition	Pin No.	Rating	Unit	Remarks
Human Body Model	C = 100pF, R = 1.5k $\Omega$	All pins	$\pm 2000$	V	
Machine Model	C = 200, R = 0k $\Omega$	All pins	$\pm 300$	V	
CDM	-	All pins	$\pm 800$	V	

**ELECTRICAL CHARACTERISTICS**

(Ta = 25°C, Vcc=3V. unless otherwise specified)

FM F/E : f = 98MHz, fm = 1kHz, Δf = 22.5kHz AM : f = 1MHz, fm = 1kHz, 30% Mod

FM IF : f = 10.7MHz, fm = 1kHz, Δf = 22.5kHz MPX : f = 1kHz, L+R = 90%, P = 10%, Vi = 150mV)

PARAMETER		SYMBOL	CONDITION	RATINGS			UNIT
				MIN.	TYP.	MAX.	
Supply Voltage Range		Vcc		2.0	-	9.0	V
Supply Current		Iccq1	FM, Vi = 0	7.3	11.3	15.3	mA
		Iccq2	AM, Vi = 0	3.8	6.8	9.8	mA
F/E	Input Limiting oltage	Vi lim1	Vo = -3dB	-	12	18	dBu
	Local Oscillation oltage	Vosc	fos c= 108.7MHZ	40	70	110	mV
FM IF	Input Limiting oltage	Vi lim2	Vo = -3dB	35	40	45	dBu
	Detection Output oltage	Vo det1	Vi = 80dBu	55	80	110	mV
	S/R	S/N1	Vi = 80dBu	55	65	-	dB
	FM Mute Attenuation atio	Amute	Vi = 80dBu	60	70	-	dB
	AM Depression Ratio	AMR	Vi = 80dBu	40	50	-	dB
	THD	THD1	Vi = 80dBu	-	0.2	1.0	%
	LED Turning On ensitivity	VI11	IFS[1:0] = 0	40	45	50	dBμ
		VI12	IFS[1:0] = 1	35	40	45	dBμ
VI13		IFS[1:0] = 2	30	35	40	dBμ	
VI14		IFS[1:0] = 3	24	29	34	dBμ	
AM IF	Voltage Gain	Gv1	Vi=26dBu	20	40	70	mV
	Detection Output oltage	Vo det2	Vi = 60dBu	50	70	90	mV
AM IF	S/R	S/N2	Vi = 60dBu	32	42	-	dB
	THD	THD2	Vi = 60dBu	-	1	2	%
	LED Turning On ensitivity	VI21	IFS[1:0] = 0	28	32	38	dBμ
		VI22	IFS[1:0] = 1	22	26	32	dBμ
		VI23	IFS[1:0] = 2	16	20	26	dBμ
VI24		IFS[1:0] = 3	10	14	20	dBμ	

PARAMETER		SYMBOL	CONDITION	RATINGS			UNIT		
				MIN.	TYP.	MAX.			
MPX	Maximum Input Voltage		Vimax	Stereo, THD = 3%	350	500	-	mV	
	Voltage Gain		Gv2		-5	-3	-1	dB	
	Channel Balance		CB	Mono	-1.5	0	1.5	dB	
	THD1		THD3	Mono	-	0.2	1.0	%	
	THD2		THD4	Stereo	-	0.2	1.0	%	
	Separation 1		CS1	Stereo, f = 100HZ	25	45	-	dB	
	Separation 2		CS2	Stereo, f = 1kHz	32	45	-	dB	
	Separation 3		CS3	Stereo, f = 10kHz	25	45	-	dB	
	LED Turning On ensitivity		Vlon	TUNLED=ON, Pilot only	-	8	16	mV	
	LED Turning Off ensitivity		Vloff	TUNLED=OFF, Pilot only	2	6	-	mV	
	Lamp Hysteresis		HY		-	2	-	mV	
	Capture Range		CR	Pilot only	-	8	-	%	
S/R		S/N3	Mono	65	80	-	dB		
DTS	Input Voltage	High Level	Vih	CE, DI, CL	0.7Vreg	-	-	V	
		Low Level	Vil	CE, DI, CL	0	-	0.3Vreg	V	
	Output Voltage	High Level	Voh1	PD : lo = -1mA	0.7Vreg	-	-	V	
		Low Level	Vol1	PD : lo = 1mA	-	-	0.3Vreg	V	
			Vol2	DO : lo = 5mA	0	-	0.3Vreg	V	
	Output Voltage Range		Vo	Aout	0	-	9	V	
	Internal Feedback egistance		Rf	XIN	-	0.4	-	MΩ	
	Input Current		lin1		CE, DI, CL = VDD r GND	-	-	5	μA
					XIN = VDD or GND	1.3	-	8	μA
	Supply Current		Idd1		X'tal = 10.8MHz, M = 130MHz	-	2.5	6	mA
					PLL stop mode, X'tal = 10.8MHz	-	0.3	-	mA
PLL stop mode, X'tal stop mode					-	-	10	μA	

TEST CIRCUIT

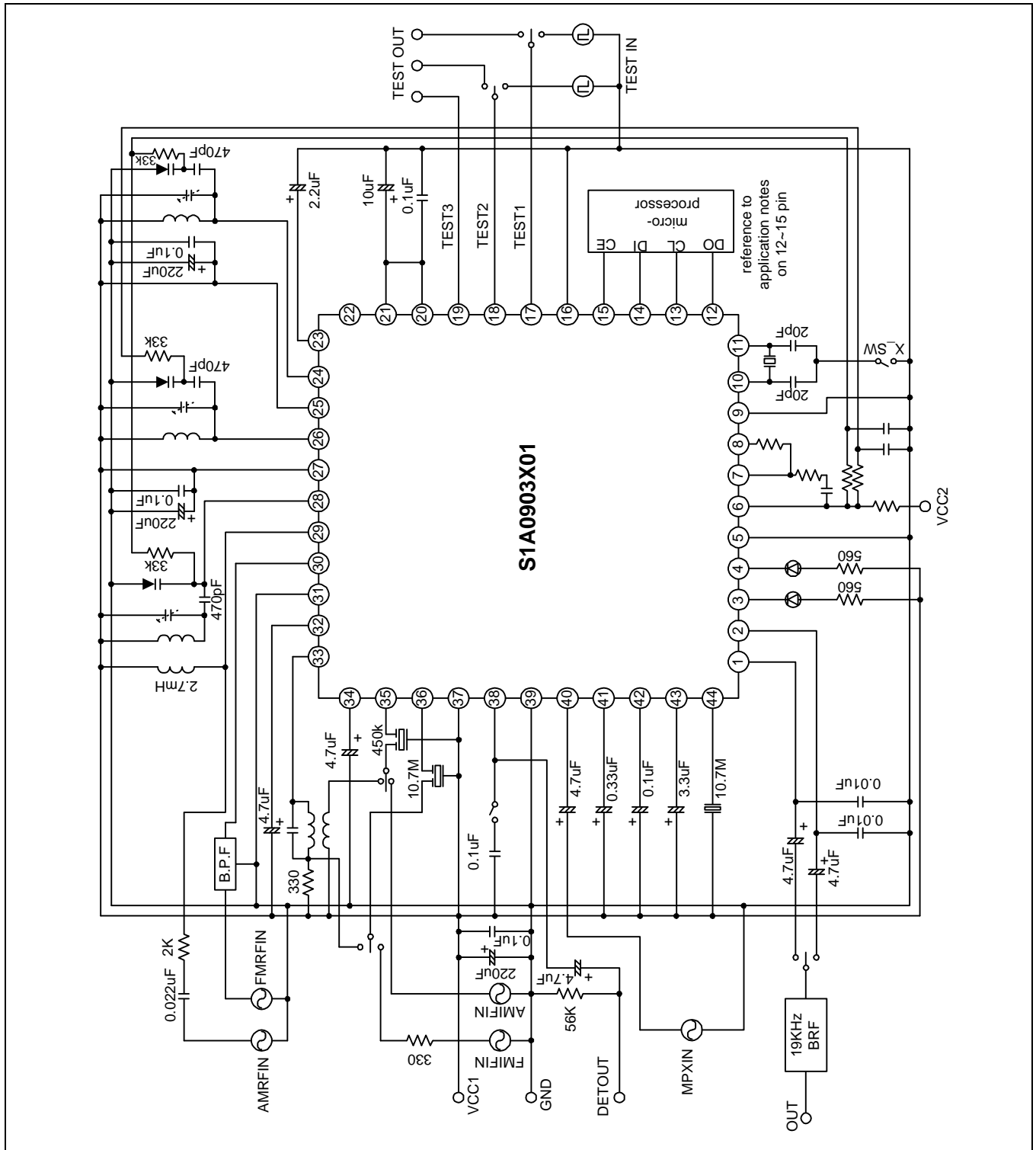



APPLICATION CIRCUIT

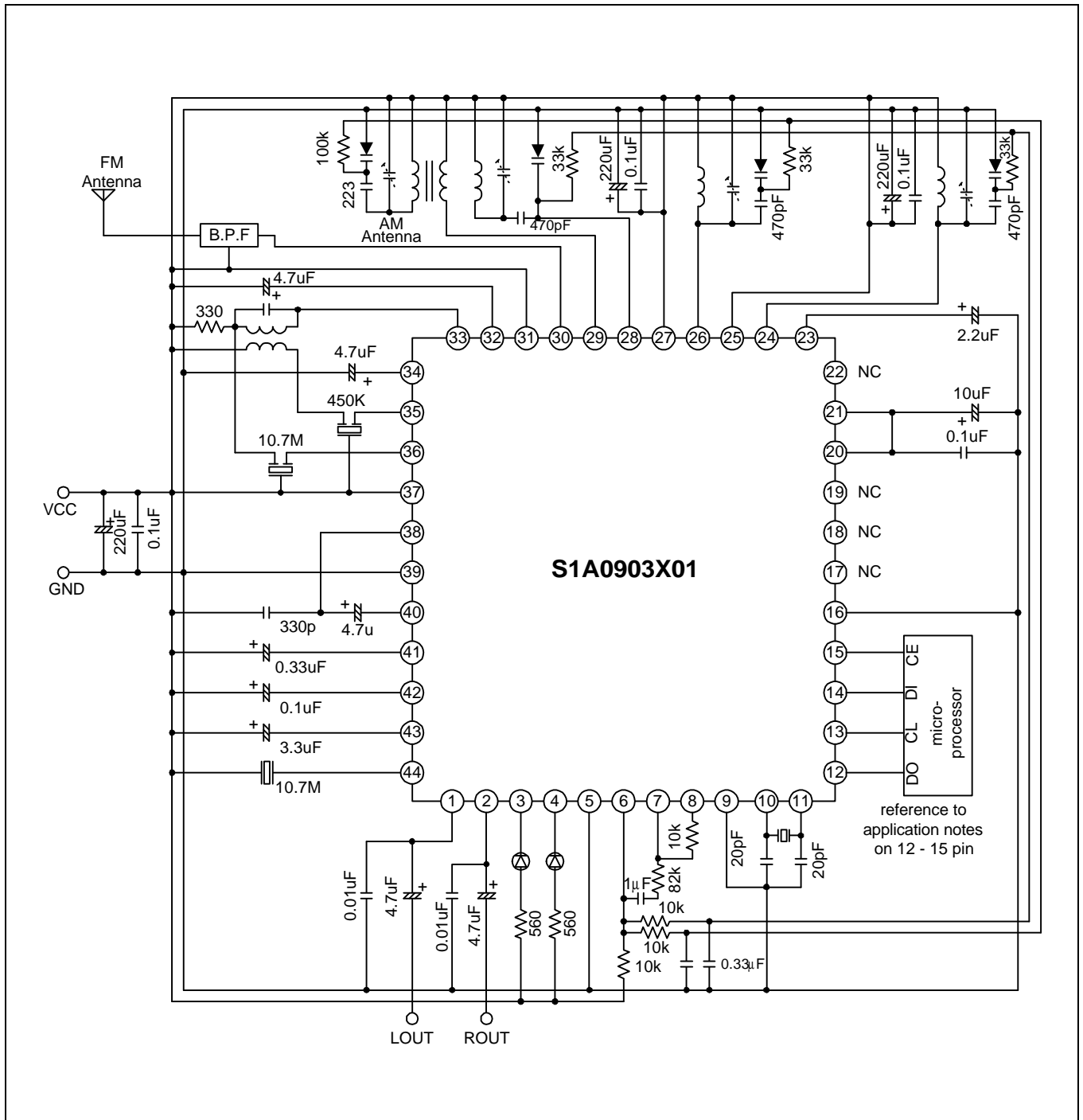

NOTES