

INTRODUCTION

The S1A2298A01 is a monolithic integrated circuit which consists of an FM IF AMP, FM QUAD DET, AM IF AMP, AM DET, MPX block and Counter output pin for a DTS (Digital Tuning System) set.

It is designed for use in portable radio cassette recorders.

FEATURES

- AM/FM IF, 1 Chip for DTS
- Wide Operating Voltage: $V_{CC} = 1.8V - 7V$
- Adjust free FM Quadrature Detector
- Adjust free MPX VCO

ORDERING INFORMATION

Device	Package	Operating Temperature
S1A2298A01-A0B0	24-SDIP-300	- 20°C - + 75°C

24-SDIP-300

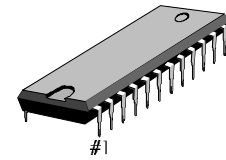

BLOCK DIAGRAM

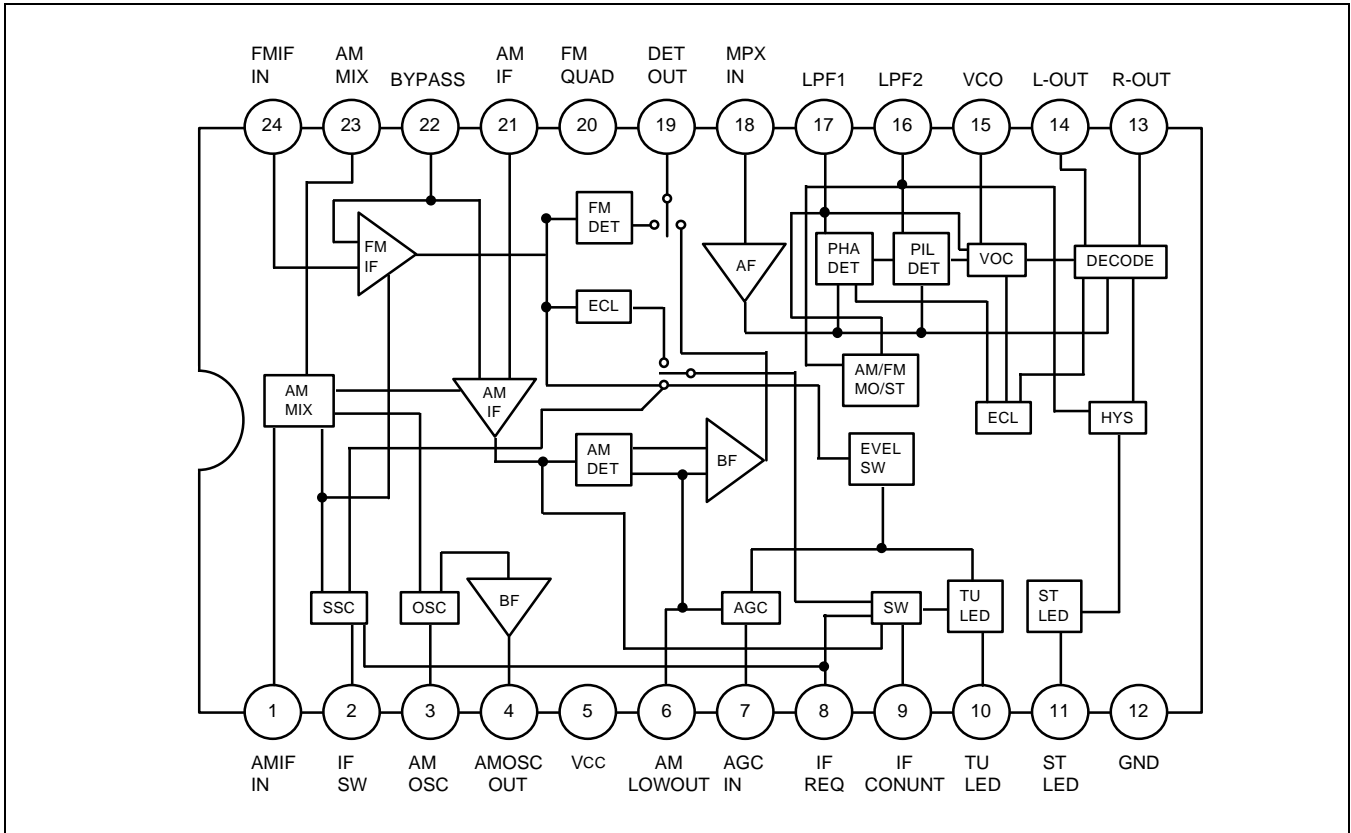

PIN CONFIGURATION

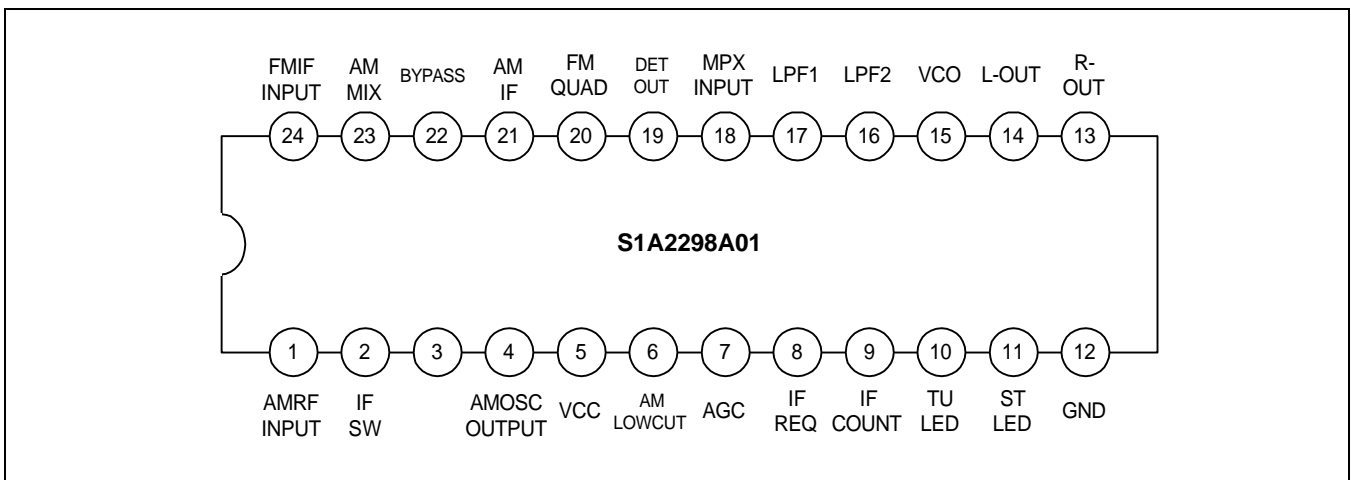

PIN FUNCTION

Pin No	Symbol	I/O	Function
1	AM RF	I	AM RF Input Pin
2	IF SW	I	IF GAIN Control Pin
3	AM OSC	O	AM Oscillator Pin
4	AM OSC BF	O	AM Oscillator Buffer Pin
5	V _{CC}		V _{CC} Pin
6	AM LOW CUT	O	AM Low Cut Pin
7	AGC	O	AGC Pin
8	IF REQ	O	IF Count Control Pin
9	IF COUNT	O	IF Count Pin
10	TU LED	O	Tuning LED Output Pin
11	ST LED	O	Stereo LED Output Pin
12	GND		Ground Pin
13	R-OUT	O	R-OUT Output Pin
14	L-OUT	O	VCO Output Pin
15	VCO	O	VCO Output Pin
16	LPF2	O	Low Pass Filter 2 Pin
17	LPF1	O	Low Pass Filter 1 Pin
18	MPX	I	MPX Input Pin
19	DET	O	AM/FM Detector Output Pin
20	QUAD	O	Quadrature Detector Pin
21	AM IF	I	AM IF Input Pin
22	BYPASS		AM/FM Bypass Pin
23	AM MIX	O	AM Mixer Pin
24	FM IF	I	FM IF Input Pin

ABSOLUTE MAXIMUM RATING (Ta = 25°C)

Characteristic	Symbol	Value	Unit
Supply Voltage	V _{CC}	8	V
Power Dissipation	P _D	1200	mW
Operating Temperature	T _{OPR}	-20 – +75	°C
Storage Temperature	T _{STG}	-55 – +150	°C

ELECTRICAL CHARACTERISTICS

(Ta = 25 °C, VCC = 3 V, unless otherwise specified)

- FM: $f_C = 10.7\text{MHz}$, $f_m = 1\text{kHz}$, $\Delta f = 22.5\text{kHz}$, $\text{SW1} = 10\text{k}\Omega$
- AM: $f_C = 1\text{MHz}$, $f_m = 1\text{kHz}$, $\text{MOD} = 30\%$, $\text{SW1} = 10\text{k}\Omega$
- MPX: $f_m = 1\text{kHz}$, $L + R = 90\%$, $\text{Pilot} = 10\%$, $V_I = 150\text{mV}$

Characteristic		Symbol	Test Conditions	Min.	Typ.	Max.	Unit
Quiescent Circuit Current		I_{CCQ1}	FM, $V_I = 0$	6.5	9.5	13.5	mA
		I_{CCQ2}	AM, $V_I = 0$	7	10	14	mA
FM	-3 dB Limiting Sensitivity	$V_{I(\text{SEN})}$	$V_O = -3\text{dB}$	41	46	51	dBu
	Detector Output Voltage	V_O	$V_I = 80\text{dBu}$	50	75	100	mV
	Signal to Noise Ratio	S/N	$V_I = 80\text{dBu}$	55	65	–	dB
	AM Rejection Ratio	AMR	$V_I = 80\text{dBu}$	–	38	–	dB
	Total Harmonic Distortion	THD	$V_I = 80\text{dBu}$	–	0.2	1.0	%
	Lamp On Level	$V_{L(\text{on})}$	$V_I = \text{variable}$	44	49	54	dBu
	IF Countout Frequency 1	F_{if1}	$V_I = 20\text{dBu}$	–	10.7	–	MHz
	IF Countout Frequency 2	$F_{1/8\text{if2}}$	$V_I = 80\text{dBu}$	1,3374	1,3375	1,3376	MHz
	IF Countout Voltage 1	V_{if1}	$V_I = 61\text{dBu}$	350	500	–	mVpp
	IF Countout Voltage 2	$V_{1/8\text{if2}}$	$V_I = 61\text{dBu}$	350	500	–	mVpp
	IF Count Sensitivity 1	S_{if1}	$\text{SW1} = 0, \text{SW2} = \text{GND}$	69	76	83	dBu
	IF Count Sensitivity 2	S_{if2}	$\text{SW1} = 0.51\text{k}\Omega, \text{SW2} = \text{GND}$	61	68	75	dBu
	IF Count Sensitivity 3	S_{if3}	$\text{SW1} = 0, \text{SW2} = V_{\text{cc}}$	70	77	83	dBu
	IF Count Sensitivity 4	S_{if4}	$\text{SW1} = 0.51\text{k}\Omega, \text{SW2} = V_{\text{cc}}$	62	69	76	dBu
AM	Detector Output Voltage 1	V_O	$V_I = 26\text{dBu}$	10	57	85	mV
	Detector Output Voltage 2	V_O	$V_I = 60\text{dBu}$	50	75	100	mV
	Total Harmonic Distortion	THD	$V_I = 60\text{dBu}$	–	1	2	%
	Signal to Noise Ratio	S/N	$V_I = 60\text{dBu}$	31	41	–	dB
	Lamp ON Level	$V_{L(\text{on})}$	$V_I = \text{variable}$	21	26	31	dBu
	Oscillation Voltage	V_{OSC}	$V_I = 0$	300	500	–	mV
	IF Count Voltage	V_{if}	$V_I = 39\text{dBu}$	350	500	–	mV
	IF Count Sensitivity 5	S_{if5}	$\text{SW1} = 0, \text{SW2} = \text{GND}$	42	49	56	dBu
	IF Count Sensitivity 6	S_{if6}	$\text{SW1} = 0.51\text{k}\Omega, \text{SW2} = \text{GND}$	35	42	49	dBu
	IF Count Sensitivity 7	S_{if7}	$\text{SW1} = 0, \text{SW2} = V_{\text{cc}}$	42	49	56	dBu
IF Count Sensitivity 8	S_{if8}	$\text{SW1} = 0.51\text{k}\Omega, \text{SW2} = V_{\text{cc}}$	35	42	49	dBu	

	Characteristic	Symbol	Test Conditions	Min.	Typ.	Max.	Unit
MPX	Channel Separation 1	CS1	Stereo, fm = 100Hz	35	42	–	dB
	Channel Separation 2	CS2	Stereo, fm = 1kHz	35	42	–	dB
	Channel Separation 3	CS3	Stereo, fm = 10kHz	35	42	–	dB
	Total Harmonic Distortion	THD	Stereo	–	0.2	1.0	%
	Total Harmonic Distortion	THD	Mono	–	0.2	1.0	%
	Maximum Input Voltage	$V_{I(MAX)}$	Stereo, THD = 3%	250	350	–	mW
	Voltage Gain	G_V	Mono	–5	–3	–1	dB
	Channel Balance	CB	Mono	–1	0	+1	dB
	Signal to Noise Ratio	S/N	Mono	68	78	–	dB
	Lamp On Level	$V_{L(on)}$	Pilot	–	8	15	mV
	Lamp Hysteresis	HY	Pilot	1	2	5	mV
	Capture Range	CR(H)	Pilot	0	1.3	3.15	%
	Capture Range	CR(L)	Pilot	–3.5	–1.3	0	%

COIL CIRCUIT

No	Function	of (kHz)	Q	L (uH)	P (pF)	Turns					Write (mmf)
						1-2	2-3	1-3	1-4	4-6	
T1	AM OSC	796	115	288	-	13	73	-	-	32	0.08
T2	AM IFT	455	120	-	75	-	-	180	-	15	0.06

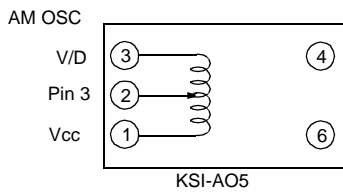
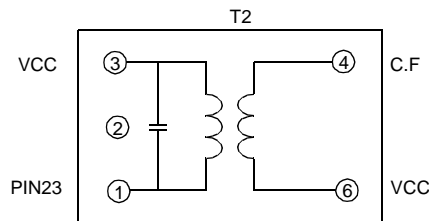
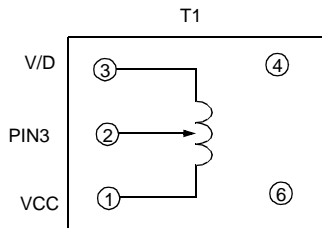

NO	F (kHz)	Qo	Turns			C.L	KWANG SUNG PART NO
			4-6	1-2	2-3		
T1	796	115	4-6	1-2	2-3	288 uH	KSI-AO5
			32	13	73		
T2	455	120	4-6		1-3	180 pF	KSI-AA1
			14		146		

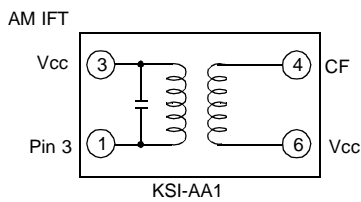

APPLICATION INFORMATION

1) IF COUNT OUTPUT

IF Count Output is determined by the Pin 8 voltage. Tuning LED switching Count output occurs at pin 9.

The output impedance is 1.5k Ω .

V8; High (TU-LED ON) : Output

Low (TU-LED OFF) : No output

2) IF Switch

IF sensitivity is determined by the resistors of SW1 (0 Ω , 0.51 K Ω , 10 K Ω) regulating the AM mixer and FM IF gain. When SW2 is V_{CC}, the count output frequency is 10.7 MHz.

When SW2 is GND, the count output frequency is 1.33375MHz, one eighth of 10.7MHz.

3) AM Low Cut

One of the signals which passed through DET AMP is provided to AF AMP, another is converted to AC before its feedback to AGC voltage and they are simultaneously used as a high frequency bypass.

4) AM OSC BUFFER

Output Impedance is 6.1k Ω , SIGNAL WAVE FORM is the rectangle wave, and the voltage scale of the OSC buffer OUTPUT is 500mVp-p.

5) MPX

INPUT IMPEDANCE: 25k Ω

OUTPUT IMPEDANCE: 5k Ω

APPLICATION CIRCUIT

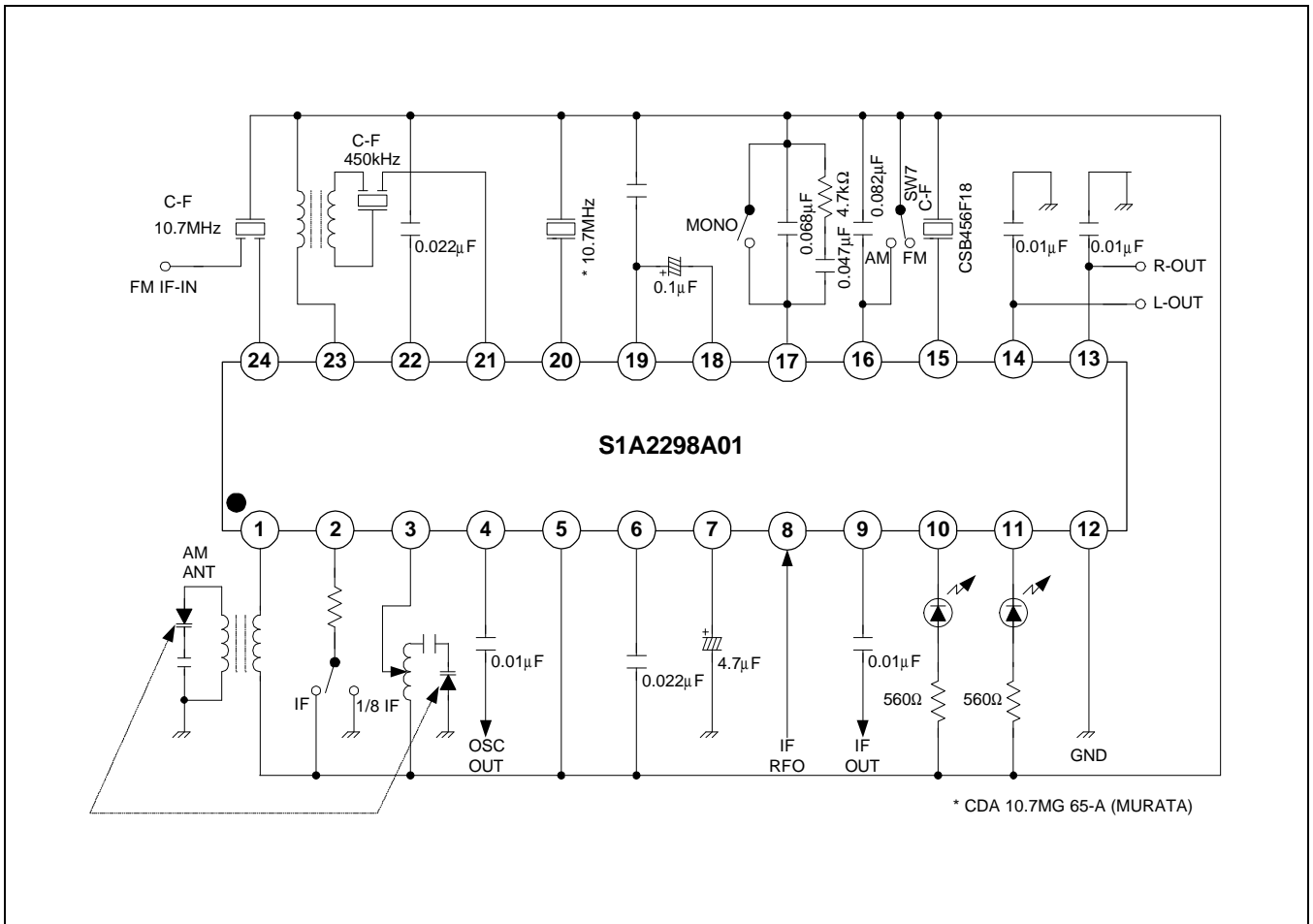

APPLICATION CIRCUIT

