

# S1C17555/565/955/965

## 16-bit Single Chip Microcontroller

- Built-in FSA (Flexible Signal processing Accelerator) function; It realize high processing with low power
- 12-bit A/D converter
- Several kinds of serial interface
- 48-pin wafer-chip-scale package (WCSP)
- Built-in the flash memory that it can write with a single power supply

### ■ DESCRIPTIONS

S1C17555/565/955/965 can operate at high speed with low power and it has large address area. These products have good points such as Space-saving package (WCSP), 12-bit A/D converter and Signal processing accelerator(FSA) every model and selectable depending on a use. In FSA, signal processing ranging from image processing to audio handling is possible. S1C17955/965 is most suitable for the application such as mobile devices. FSA realize high processing with a low clock, and realize a low consumption design by using this function.

### ■ FEATURES

機種	S1C17555	S1C17565	S1C17955	S1C17965
<b>CPU</b>				
CPU core	Seiko Epson original 16-bit RISC CPU core S1C17			
Multiplier/Divider (COPRO)	· 16-bit × 16-bit multiplier · 16-bit × 16-bit + 32-bit multiply and accumulation unit · 16-bit ÷ 16-bit divider			
<b>FSA *1</b>				
Multiply and accumulation unit	-	-	32-bit × 32-bit multiplier + 72-bit adder	
Data access	-	-	2 inputs and 1 output	
Address space	-	-	12K bytes	
<b>Embedded Flash memory</b>				
Capacity	128K bytes (for both instructions and data)			
Erase/program count	40 times (min.) (Applied only when FLS V1.0 or later is used.)			
Other	· Read/program protection function · An embedded power supply booster for erasing/programming · Allows on-board programming using a debugging tool such as ICDmini.			
<b>Embedded RaM</b>				
RAM1 Capacity	4K bytes			
RAM2 (FSA RAM) Capacity	12K bytes			
<b>Clock generator (ClG)</b>				
System clock source	2 sources (IOSC/OSC1)	3 sources (IOSC/OSC1/OSC3)	2 sources (IOSC/OSC1)	3 sources (IOSC/OSC1/OSC3)
IOSC oscillator circuit	2/4/8/12 MHz (typ.) internal oscillator circuit			
OSC3 oscillator circuit	-	24 MHz (max.) crystal or ceramic oscillator circuit Supports an external clock input.	-	24 MHz (max.) crystal or ceramic oscillator circuit Supports an external clock input.
OSC1 oscillator circuit	32.768 kHz (typ.) crystal oscillator circuit. Supports an external clock input.			
Other	· Core clock frequency control · Peripheral module clock supply control			
<b>I/O ports (P)</b>				
Number of general-purpose I/O ports	Max. 20 bits	Max. 24 bits	Max. 20 bits	Max. 24 bits
	Pins are shared with the peripheral I/O.			
<b>Serial interfaces</b>				
8-bit SPI (SPI)	2 channels			
16-bit SPI (SPI16)	1 channel			
I <sup>2</sup> C master (I2CM)	1 channel			
I <sup>2</sup> C slave (I2CS)	1 channel			
UART (UART)	1 channel (IrDA1.0 supported)	2 channels (IrDA1.0 supported)	1 channel (IrDA1.0 supported)	2 channels (IrDA1.0 supported)
IR remote controller (REMC)	-	1 channel	-	1 channel
<b>Timers</b>				
16-bit timer (T16)	3 channels			
Fine mode 16-bit timer (T16F)	2 channels			
16-bit PWM timer (T16A2)	4 channels			
Clock timer (CT)	1 channel			
Stopwatch timer (SWT)	1 channel			
Watchdog timer (WDT)	1 channel			

# S1C17555/565/955/965

12-bit A/D converter (aDC12Sa)				
Conversion method	-	Successive approximation type	-	Successive approximation type
Analog input channel	-	6 channels (Three channels can only be used for multichannel conversion.)	-	6 channels (Three channels can only be used for multichannel conversion.)
Resolution	-	12 bits	-	12 bits
Interrupts				
Reset interrupt	#RESET pin			
NMI	Watchdog timer			
Programmable interrupts	21 systems (8 levels)	22 systems (8 levels)	21 systems (8 levels)	22 systems (8 levels)
Power supply voltage				
Core voltage (LVDD)	1.65 V to 1.95 V	1.65 V to 1.95 V (Not required when the regulator is used)	1.65 V to 1.95 V	1.65 V to 1.95 V (Not required when the regulator is used)
I/O voltage (HVDD)	1.65 V to 3.6 V	2.0 V to 3.6 V (When the regulator is used) 1.65 V to 3.6 V (When the regulator is not used)	1.65 V to 3.6 V	2.0 V to 3.6 V (When the regulator is used) 1.65 V to 3.6 V (When the regulator is not used)
Analog voltage (AVDD)	-	2.7 V to 3.6 V (Not required when the regulator is used)	-	2.7 V to 3.6 V (Not required when the regulator is used)
Flash programming voltage (VPP)	7.5 V (Not required when the regulator/booster is used.)			
Regulators				
LVDD regulator	-	Input: 2.0 V to 3.6 V Output: 1.8 V	-	Input: 2.0 V to 3.6 V Output: 1.8 V
AVDD regulator	-	Input: 3.1 V to 3.6 V, Output: 2.8 V	-	Input: 3.1 V to 3.6 V, Output: 2.8 V
VPP regulator/booster	Input: 2.4 V to 3.6 V Output: 7.5 V			
Operating temperature				
Operating temperature range	-40°C to 85°C (10 to 40°C when programing/erasing the Flash)			
Current consumption (Typ. value, IVDD = hVDD = 1.8 V, regulator not used)				
SLEEP state	1.0 µA (IOSC = Off, OSC1 = Off, OSC3 = Off)			
HALT state	2.9 µA (IOSC = Off, OSC1 = 32 kHz, OSC3 = Off)			
Run state	3500 µA (IOSC = 12 MHz, OSC1 = Off, OSC3 = Off)			
FSA operating current	-	+270 µA/MHz		
Shipping form				
1	WCSP-48 3.863 × 3.863 × 0.8 mm, ball pitch: 0.5 mm	TQFP13-64pin 10 × 10 × 1.0 mm, lead pitch: 0.5 mm	WCSP-48 3.863 × 3.863 × 0.8 mm, ball pitch: 0.5 mm	TQFP13-64pin 10 × 10 × 1.0 mm, lead pitch: 0.5 mm
2		Die form 3.863 × 3.863 mm, pad pitch: 140 µm		Die form 3.863 × 3.863 mm, pad pitch: 140 µm

\*1 For more information on the FSA, please contact Seiko Epson.

# S1C17555/565/955/965

## ■ BLOCK DIAGRAM

S1C17555

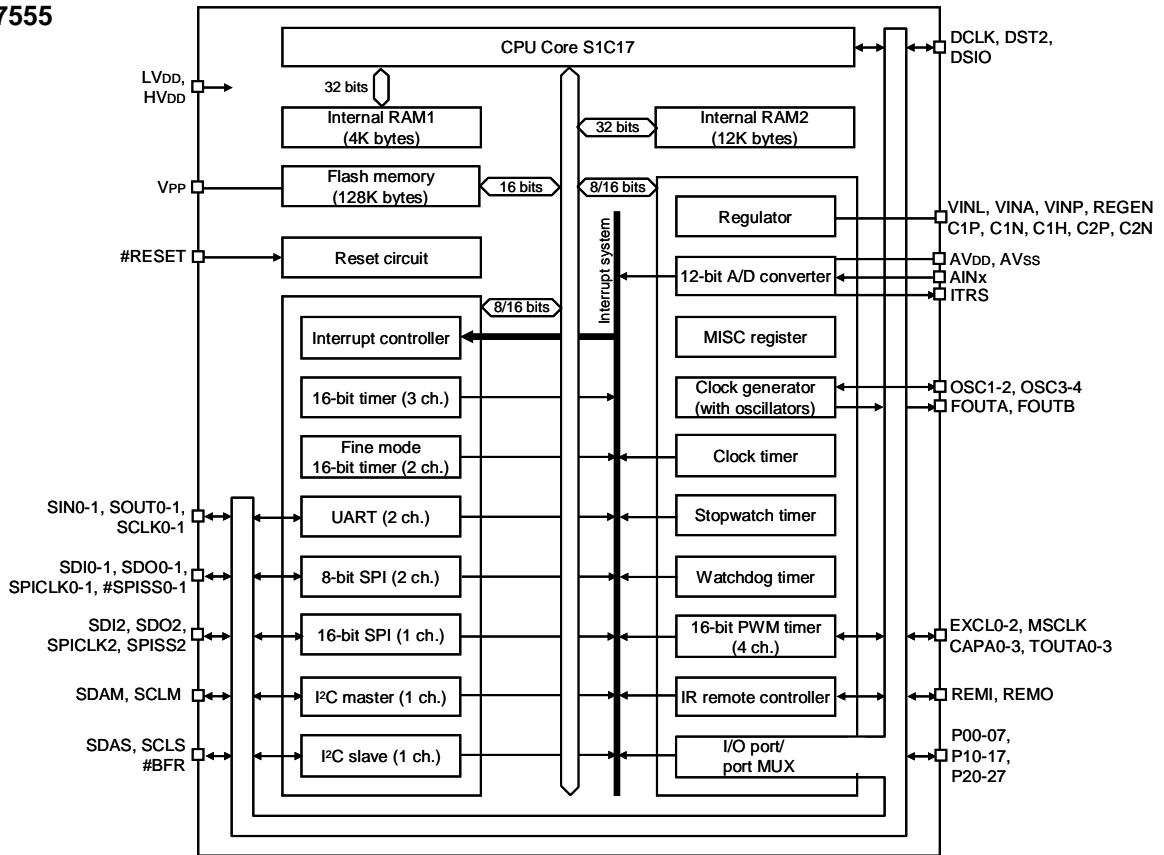

S1C17565

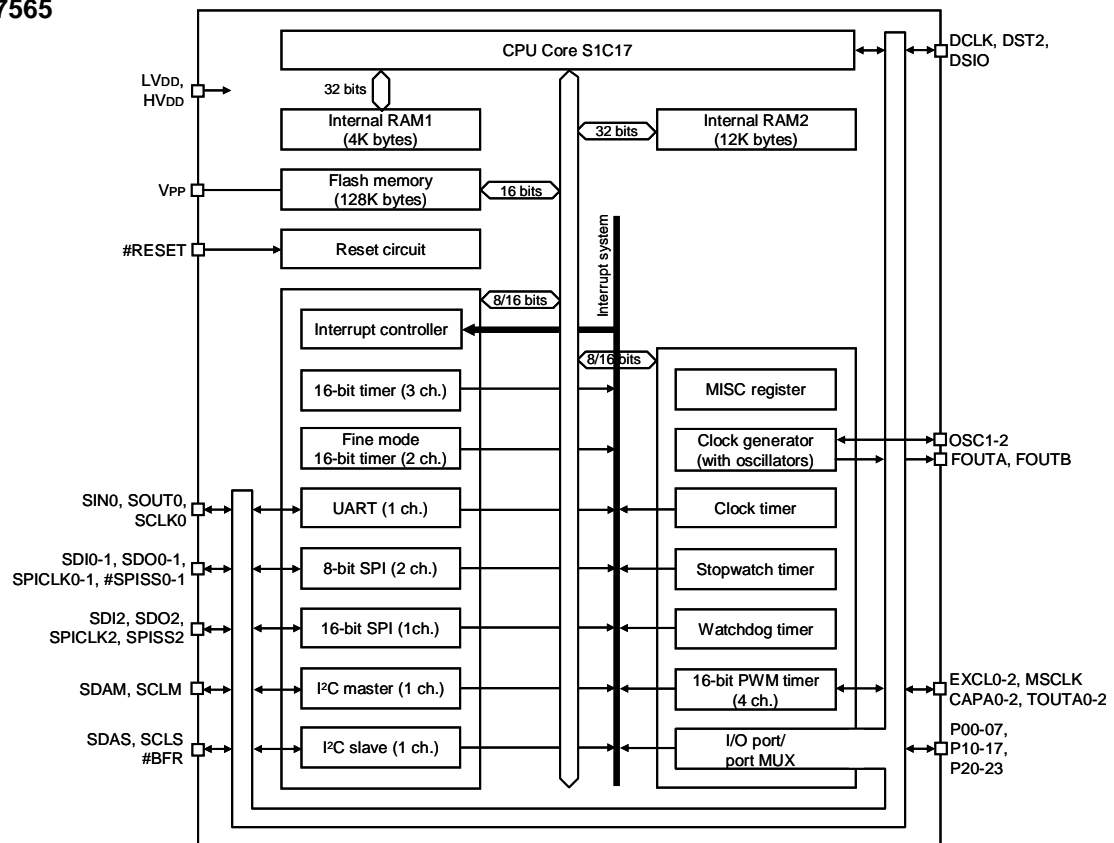

# S1C17555/565/955/965

**S1C17955**

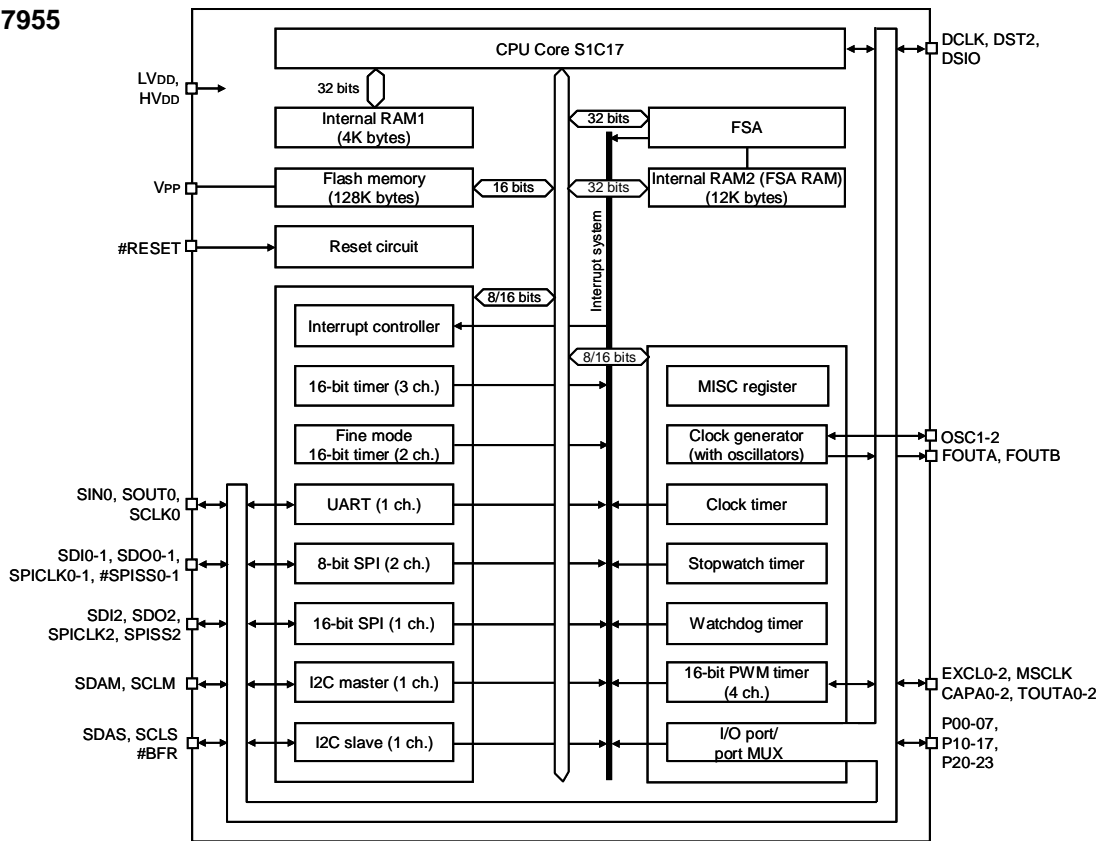

**S1C17965**

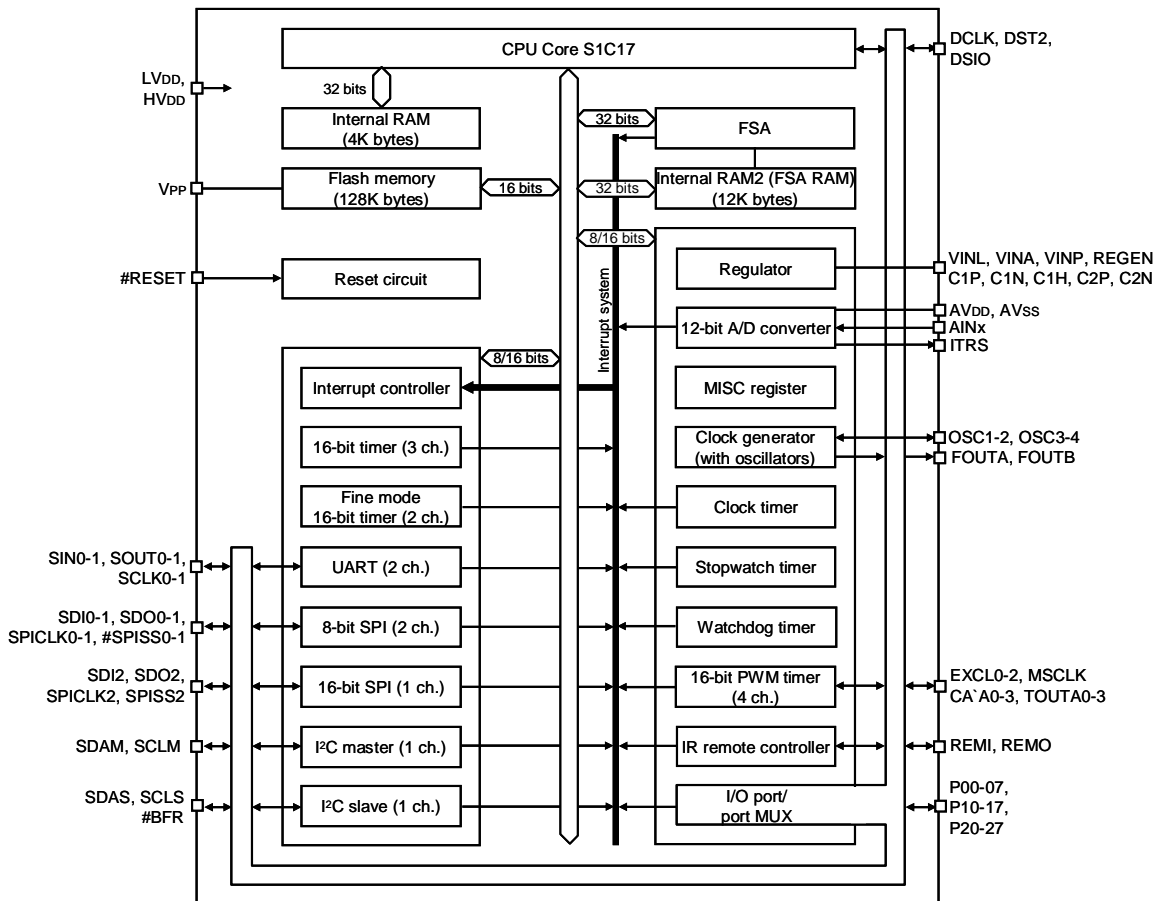

# S1C17555/565/955/965

---

## NOTICE:

No part of this material may be reproduced or duplicated in any form or by any means without the written permission of Seiko Epson. Seiko Epson reserves the right to make changes to this material without notice. Seiko Epson does not assume any liability of any kind arising out of any inaccuracies contained in this material or due to its application or use in any product or circuit and, further, there is no representation that this material is applicable to products requiring high level reliability, such as, medical products. Moreover, no license to any intellectual property rights is granted by implication or otherwise, and there is no representation or warranty that anything made in accordance with this material will be free from any patent or copyright infringement of a third party. When exporting the products or technology described in this material, you should comply with the applicable export control laws and regulations and follow the procedures required by such laws and regulations. You are requested not to use, to resell, to export and/or to otherwise dispose of the products (and any technical information furnished, if any) for the development and/or manufacture of weapon of mass destruction or for other military purposes.

All brands or product names mentioned herein are trademarks and/or registered trademarks of their respective companies.  
©Seiko Epson Corporation 2012, All rights reserved

---

## SEIKO EPSON CORPORATION

### MICRODEVICES OPERATIONS DIVISION

#### IC Sales & Marketing Department

421-8 Hino, Hino-shi, Tokyo 191-8501, JAPAN  
Phone: +81-42-587-5814 FAX: +81-42-587-5117

EPSON semiconductor website

[http://www.epson.jp/device/semicon\\_e/](http://www.epson.jp/device/semicon_e/)

Document code: 412473600  
First issue Dec., 2012 in Japan