

INTRODUCTION

The S1C7309X01 is a bipolar monolithic integrated circuit for B/W CCD camera 1 chip signal processor.

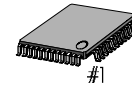
FUNCTION

- CDS (Correlated Double Sampling)
- AGC (Automatic Gain Control)
- Gamma & Knee
- Horizontal Aperture
- Video Setup
- Video Driver
- OP-Amp.
- Comparator

FEATURE

- 5 Steps Sample & Hold
- 4 to 32 dB AGC gain control
- Built-in 2 comparators for EE mode control
- EE mode WND/BLK selectable
- Gamma $\gamma = 0.40$ to 0.65 / Linear
- Built-in OP-Amp. for AGC loop
- Built-in Delay Line for Horizontal Aperture
- 3 Mode set-up control
- 2 Mode white-clip control
- 75 ohm video driver & sag compensation
- PACKAGE: 48-VQFP-0707

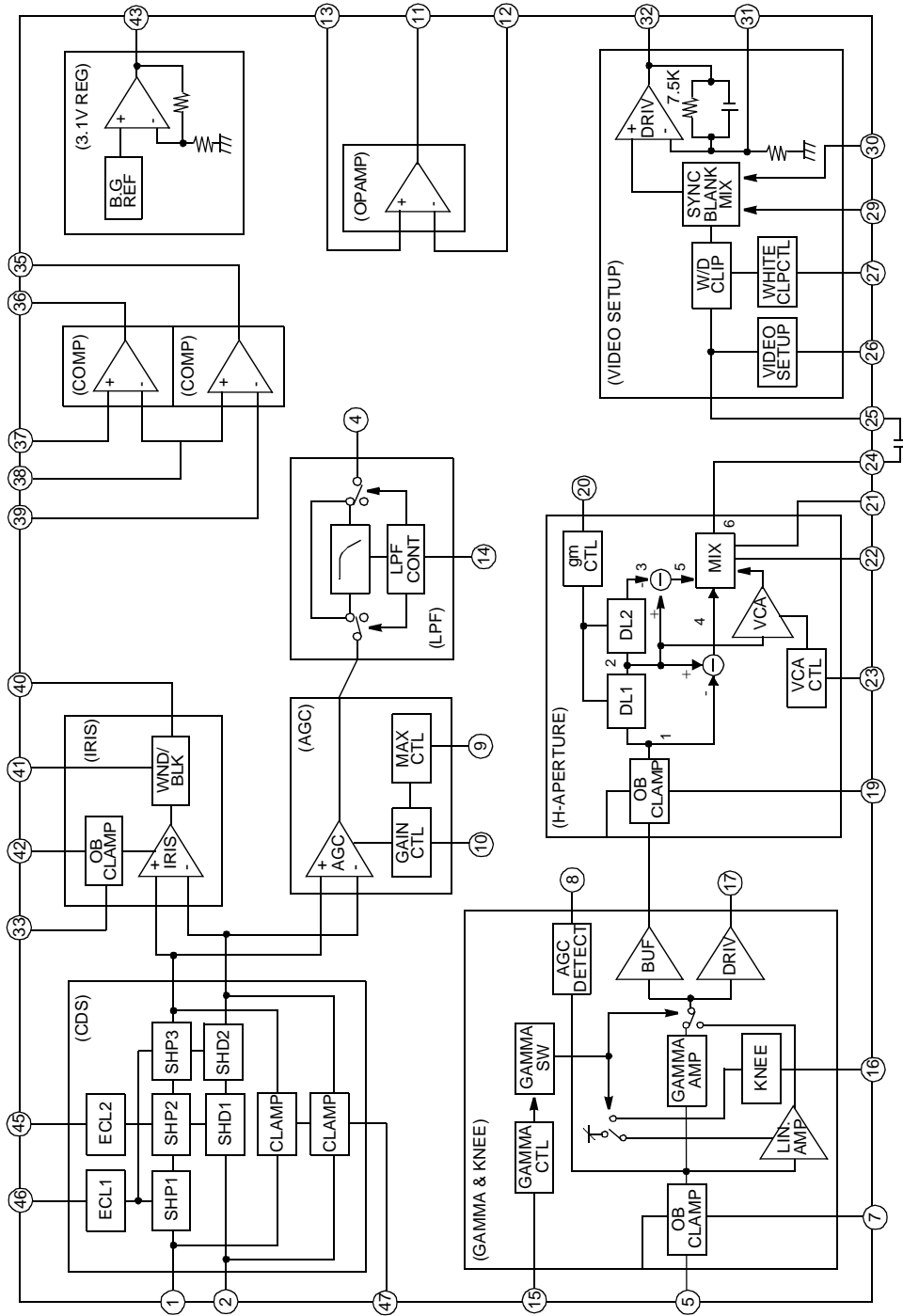
48-QFP-0707



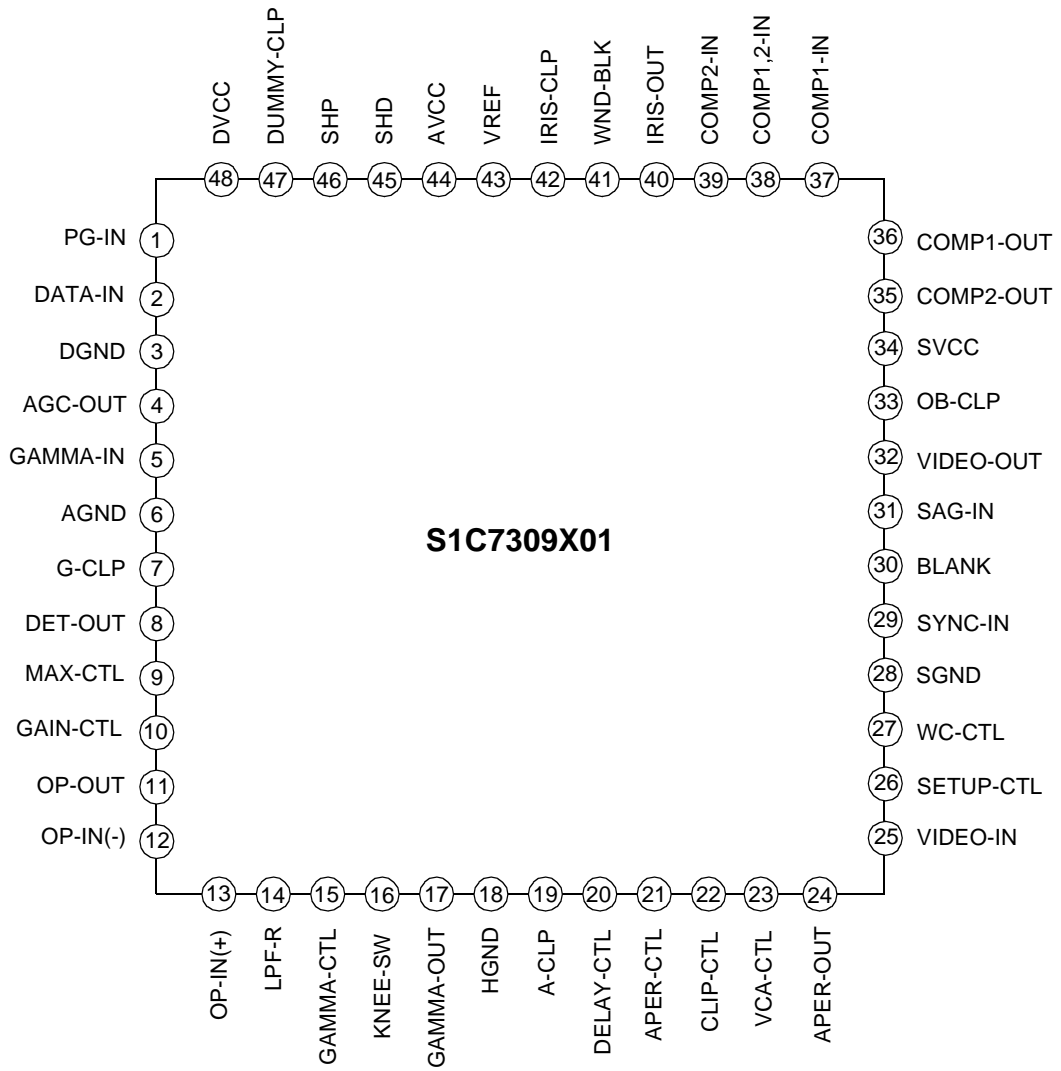
ORDERING INFORMATION

Device	Package	Operating
S5C7212X01-E0R0	48-QFP-0707	-20 °C – 75 °C

BLOCK DIAGRAM



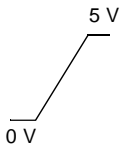
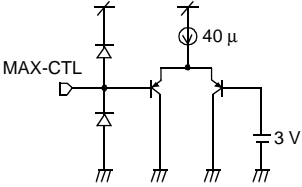
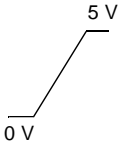
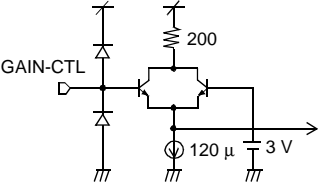
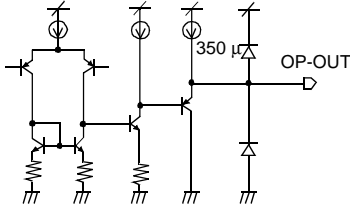
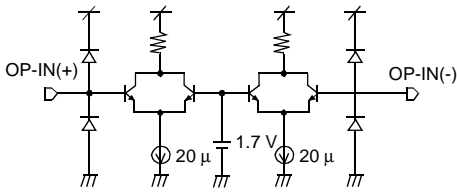
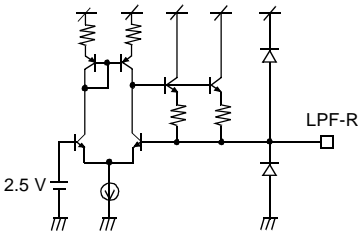
PIN CONFIGURATION

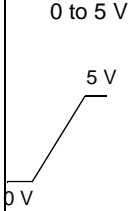
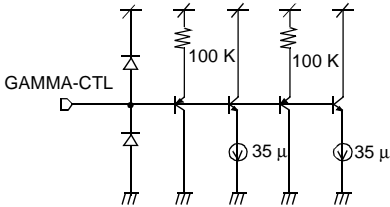
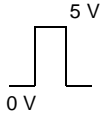
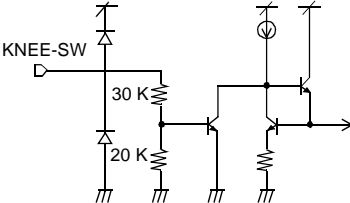
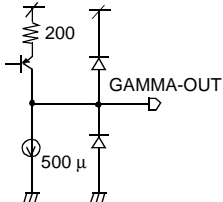
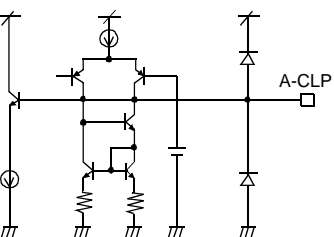
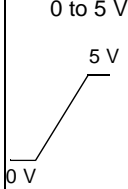
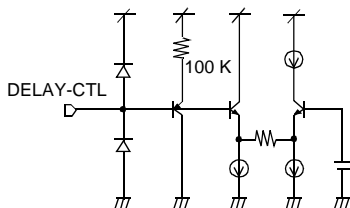


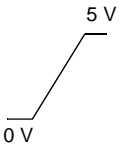
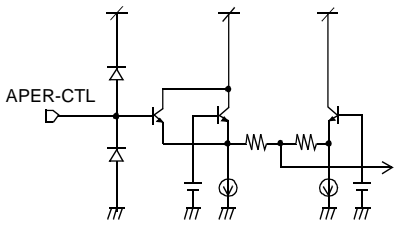
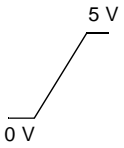
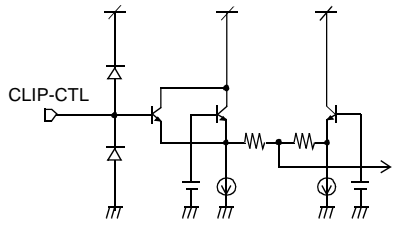
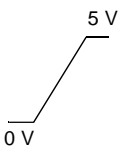
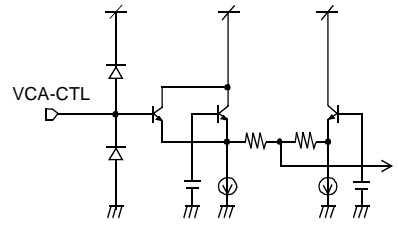
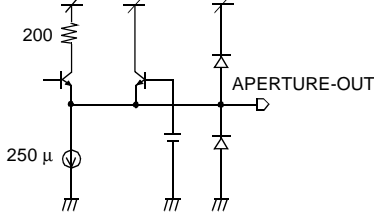
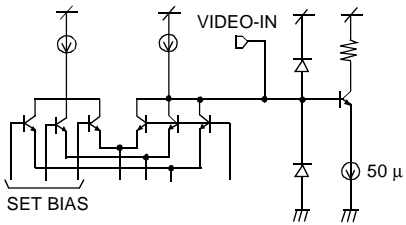
PIN EXPLANATION

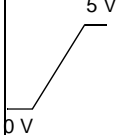
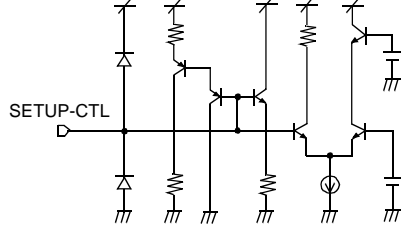
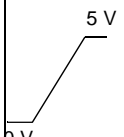
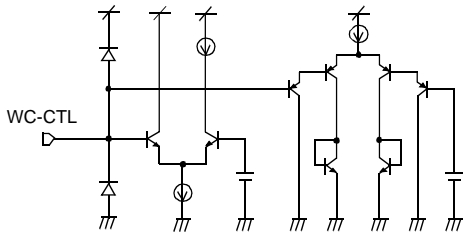

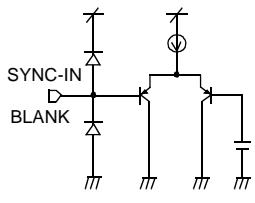
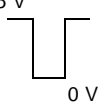
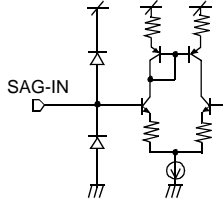
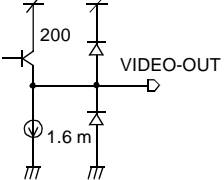
Table 1.

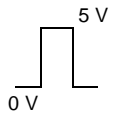
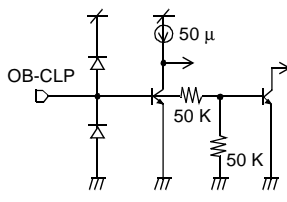
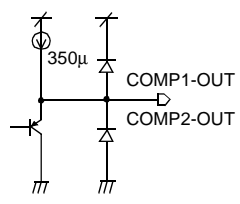
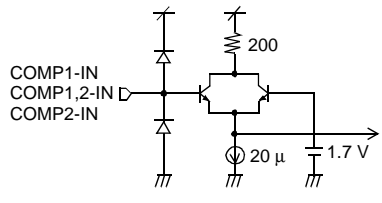
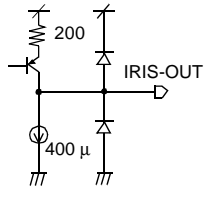
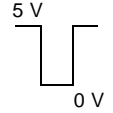
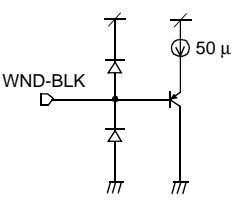
Pin No	Name	I/O	DC LEVEL	EQUIVALENT CIRCUIT
1	PG-IN	I	3.0 V	
2	DATA-IN	I	3.0 V	
3	DGND	GND		
4	AGC-OUT	O	2.0 V	
5	GAMMA-IN	I	-	
6	AGND	GND		
7	G-CLP	I/O	-	
8	DET-OUT	O	2.0 V	

Pin No	Name	I/O	DC LEVEL	EQUIVALENT CIRCUIT
9	MAX-CTL	I	0 to 5 V 	
10	GAIN-CTL	I	0 to 5 V 	
11	OP-OUT	O	-	
12	OP-IN(-)	I	-	
13	OP-IN(+)	I	-	
14	LPF-R	I/O	2.5 V	

Pin No	Name	I/O	DC LEVEL	EQUIVALENT CIRCUIT
15	GAMMA-CTL	I	0 to 5 V 	
16	KNEE-SW	I	0 V to 5 V 	
17	GAMMA-OUT	O	1.9 V	
18	HGND	GND	-	
19	A-CLP	I/O	-	
20	DELAY-CTL	I	0 to 5 V 	

Pin No	Name	I/O	DC LEVEL	EQUIVALENT CIRCUIT
21	APER-CTL	I	0 to 5 V 	
22	CLIP-CTL	I	0 to 5 V 	
23	VCA-CTL	I	0 to 5 V 	
24	APERTURE-OUT	O	1.8 V	
25	VIDEO-IN	I	-	

Pin No	Name	I/O	DC LEVEL	EQUIVALENT CIRCUIT
26	SETUP-CTL	I	0 to 5 V 	
27	WC-CTL	I	0 to 5 V 	
28	SGND	GND		
29	SYNC-IN	I	5 V 0 V 	
30	BLANK	I	5 V 0 V 	
31	SAG-IN	I	-	
32	VIDEO-OUT	O	-	

Pin No	Name	I/O	DC LEVEL	EQUIVALENT CIRCUIT
33	OB-CLP	I		
34	SVCC	VCC		
35	COMP2-OUT	O	-	
36	COMP1-OUT	O	-	
37	COMP1-IN	I	-	
38	COMP1,2-IN	I	-	
39	COMP2-IN	I	-	
40	IRIS-OUT	O	1.25 V	
41	WND-BLK	I		

Pin No	Name	I/O	DC LEVEL	EQUIVALENT CIRCUIT
42	IRIS-CLP	I/O	-	
43	VREF	O	3.1 V	
44	AVCC	VCC	-	
45	SHD	I		
46	SHP	I		
47	DUMMY-CLP	I		
48	DVCC	VCC	-	

ABSOLUTE MAXIMUM RATING (Ta=25 °C)

Characteristic	Symbol	Value	Unit
Power supply voltage	V _{CC}	7	V
Power Dissipation	P _d	500	mW
Operation Temperature	T _{OPR}	-20 ~ +75	°C
Storage Temperature	T _{STR}	-65 ~ +150	°C

ELECTRO-STATIC DISCHARGE

REF. Device	-		Test Sample Quantity			- EX	
	TEST CONDITION		E. S. D.			UNIT	REMARK
	C	R	PIN NO.	DESIGN TARGET	REF. DEVICE		
HBM	100 pF	1.5 K	ALL PIN	± 1500 ↑	-	V	

TEMPERATURE CHARACTERISTICS (VCC=5 V, Ta=25 °C)

Characteristics	Symbol	Value	Unit
AGC out DC	V04	Normal Value ± 5 %	V
Detect out DC	V08	Normal Value ± 5 %	V
IRIS AMP. out DC	V40	Normal Value ± 5 %	V
γ AMP. out	V17	Normal Value ± 5 %	mVp-p
Sync level	Vsy	Normal Value ± 5 %	mVp-p

ELECTRIC CHARACTERISTICS ($V_{CC}=5\text{ V}$, $T_a=25\text{ °C}$)

Characteristics	Condition	Symbol	Spec			Unit
			Min.	Typ.	Max.	
Operating Voltage	-	VCC	4.75	5.0	5.25	V
Supply Current	-	ICC	29	46	63	mA
VREF DC	-	VREF	2.9	3.1	3.3	V
AGC Max Ctrl Min Gain	MAX-CTL=5 V, GAIN-CTL=1.5 V DATA-IN=100 mV	G04A	-	18	20	dB
AGC Ctrl Min Gain	MAX-CTL=5 V, GAIN-CTL=5.0 V DATA-IN=500 mV	G04B	2	4	6	dB
AGC Ctrl Max Gain	MAX-CTL=0 V, GAIN-CTL=1.5 V DATA-IN=30 mV	G04B	30	32	-	dB
AGC Ctrl 10dB Gain	MAX-CTL=0 V, GAIN-CTL=3.6 V DATA-IN=320 mV	G04B	8	10	12	dB
AGC Out DC	-	V04	1.6	1.9	2.2	V
Detect Out DC Level	-	V08	1.8	2.0	2.2	V
Iris Amp Out DC Level	-	V40	1.05	1.25	1.45	V
Iris Amp Gain	DATA-IN=300 mV, f=500 kHz	G40	8	10	12	dB
Linear Amp DC Level	GAMMA-CTL=5.0 V	V17L	1.5	1.8	2.1	V
Linear Amp Gain	GAMMA-CTL=5.0 V, VIN=500mV	G17L	1.6	2.6	3.6	dB

ELECTRIC CHARACTERISTICS ($V_{CC}=5\text{ V}$, $T_a=25\text{ }^\circ\text{C}$)

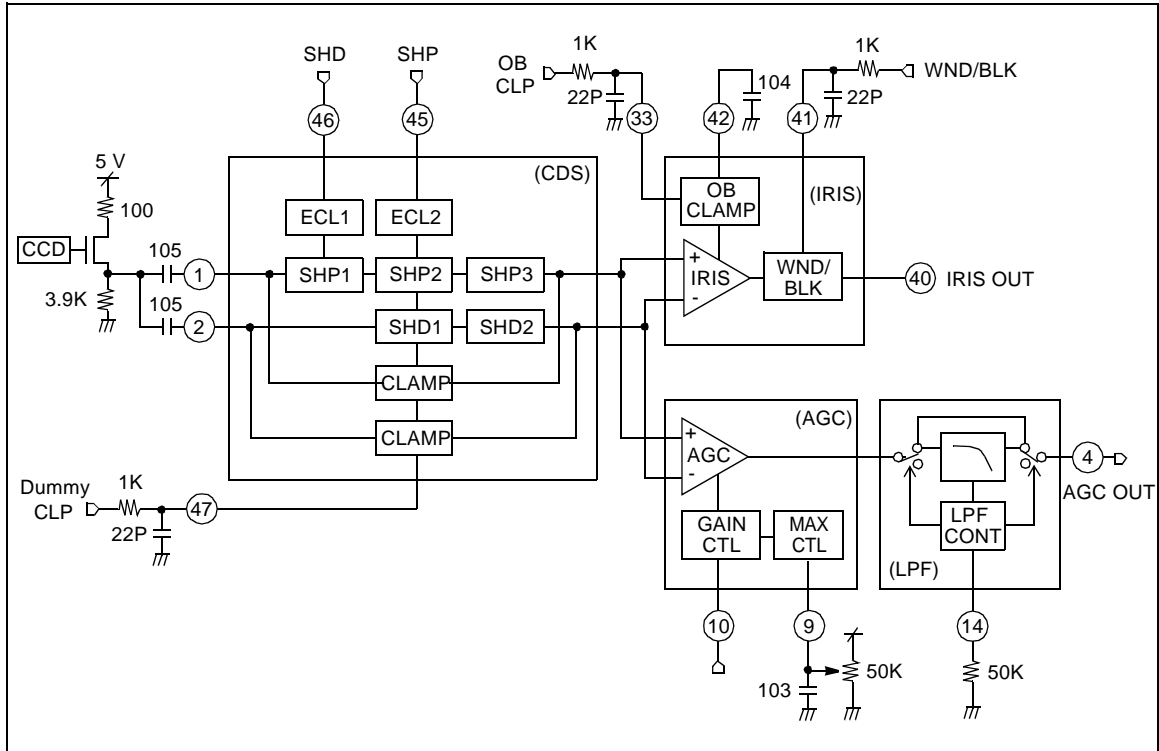
Characteristics	Condition	Symbol	Spec			Unit
			Min.	Typ.	Max.	
Gamma Out DC	GAMMA-CTL=0 V	V17G	1.65	1.85	2.05	V
KNEE OFF GAMMA AMP LEVEL 1 ($\gamma=0.45$)	GAMMA-CTL=0 V KNEEW-SW=5 V	VIN=200 mV V17G1A	0.38	0.48	0.58	V
		VIN=500 mV V17G1B	0.62	0.72	0.82	
		VIN=700 mV V17G1C	0.74	0.84	0.94	
KNEE OFF GAMMA AMP LEVEL 2 ($\gamma=0.40$)	GAMMA-CTL=1.4 V KNEEW-SW=5 V	VIN=200 mV V17G2A	0.39	0.49	0.59	V
		VIN=500 mV V17G2B	0.62	0.72	0.82	
		VIN=700 mV V17G2C	0.72	0.82	0.92	
KNEE OFF GAMMA AMP LEVEL 3 ($\gamma=0.65$)	GAMMA-CTL=4.1 V KNEEW-SW=5 V	VIN=200 mV V17G3A	0.29	0.39	0.49	V
		VIN=500 mV V17G3B	0.62	0.72	0.82	
		VIN=700 mV V17G3C	0.78	0.88	0.98	
KNEE ON GAMMA AMP LEVEL 1 ($\gamma=0.45$)	GAMMA-CTL=0 V KNEEW-SW=0 V	VIN=200 mV V17K1A	0.38	0.48	0.58	V
		VIN=500 mV V17K1B	0.57	0.67	0.77	
		VIN=700 mV V17K1C	0.64	0.74	0.84	
KNEE ON GAMMA AMP LEVEL 2 ($\gamma=0.40$)	GAMMA-CTL=1.4 V KNEEW-SW=0 V	VIN=200 mV V17K2A	0.39	0.49	0.59	V
		VIN=500 mV V17K2B	0.57	0.67	0.77	
		VIN=700 mV V17K2C	0.62	0.72	0.82	
KNEE ON GAMMA AMP LEVEL 3 ($\gamma=0.40$)	GAMMA-CTL=4.1 V KNEEW-SW=0 V	VIN=200 mV V17K3A	0.30	0.40	0.50	V
		VIN=500 mV V17K3B	0.57	0.67	0.77	
		VIN=700 mV V17K3C	0.69	0.79	0.89	

ELECTRIC CHARACTERISTICS ($V_{CC}=5\text{ V}$, $T_a=25\text{ }^\circ\text{C}$)

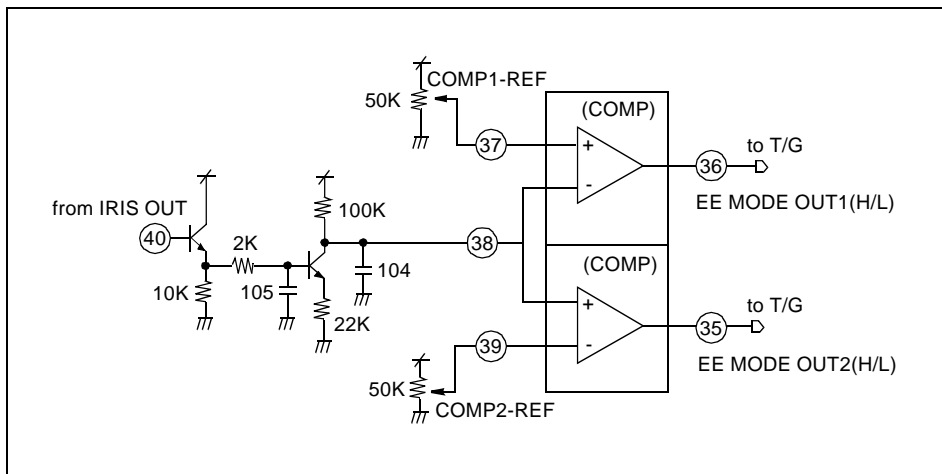
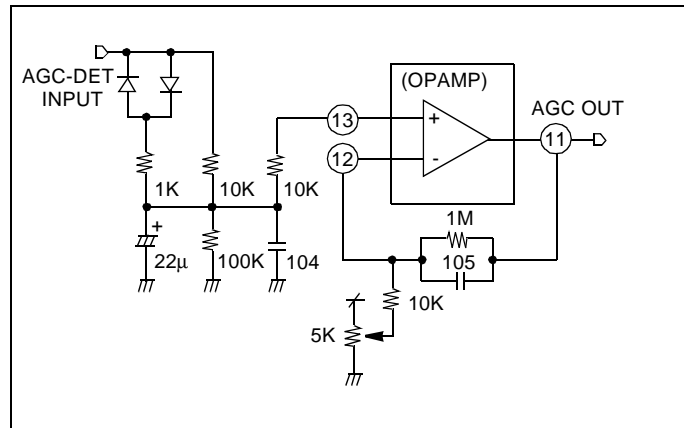
Characteristics	Condition	Symbol	Spec			Unit
			Min.	Typ.	Max.	
VCA Max Gain	VCA-CTL=5.0 V, CLIP-CTL=0 V VIN=500 mV, f=500 kHz	G24A	1.0	4.0	7.0	dB
VCA Typ Gain	VCA-CTL=3.25 V, CLIP-CTL=0 V VIN=500mV, f=500 kHz	G24B	-2	0	2	dB
VCA Min Gain	VCA-CTL=1.0 V, CLIP-CTL=0 V VIN=500mV, f=500 kHz	G24C	-10	-7	-4	dB
H-Aperture Out DC	VCA-CTL=3.25 V, CLIP-CTL=0 V	V24	1.45	1.75	2.05	V
Video Amp Out DC		V32	1.0	1.3	1.6	V
Video Amp Gain		G32	-1.0	0	1.0	dB
Sync Level		Vsync	256	286	316	mVpp
Set-Up Level 1	SETUP-CTL=0.0 V	Vset 1	-20	0	20	mVpp
Set-Up Level 2	SETUP-CTL=5.0 V	Vset2	0	20	40	mVpp
Set-Up Level 3	SETUP-CTL=1.75 V	Vset3	-	-25	-3	mVpp
Set-Up Level 4	SETUP-CTL=3.3 V	Vset4	80	130	-	mVpp
White Clip Level 1	WC-CTL1=0.0 V	Vwc1	760	820	880	mVpp
White Clip Level 2	WC-CTL2=2.0 V	Vwc2	-	300	600	mVpp
White Clip Level 3	WC-CTL3=5.0 V	Vwc3	1.1	1.3	1.5	mVpp
OP Amp Gain		G11	4	6	8	dB
OP Amp Dynamic Range		D11	3.3	-	-	Vpp
EE Comparator Out H'Level	Vin(+)=2.6V, Vin(-)=2.5 V	Vch	4.5	-	-	V
EE Comparator Out L'Level	Vin(+)=2.5V, Vin(-)=2.6 V	Vcl	-	-	1.2	V

OPERATING PRINCIPLES & METHOD

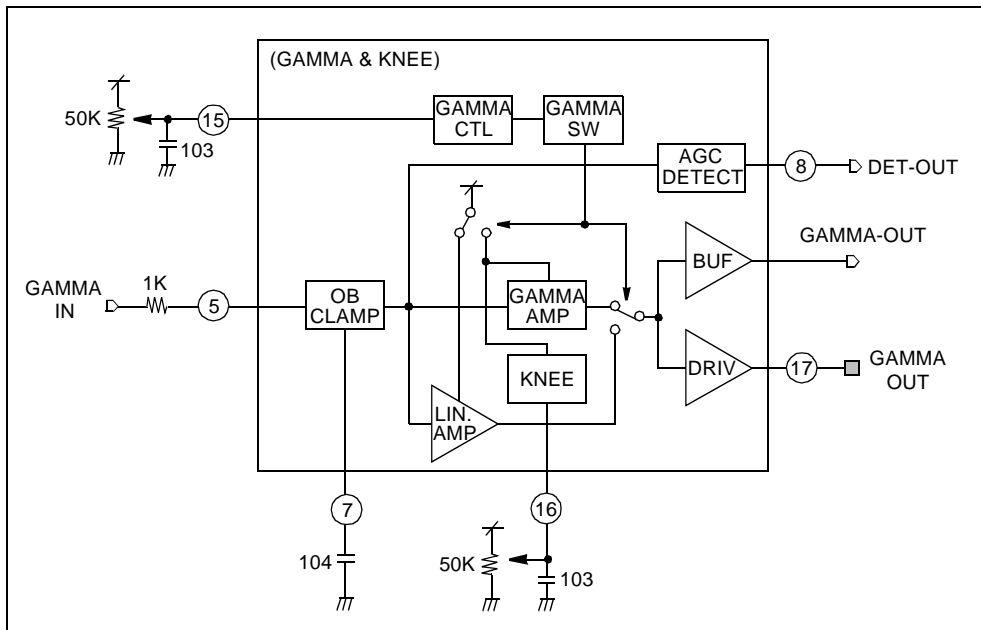
1. CDS/AGC AMP/IRIS AMP BLOCK



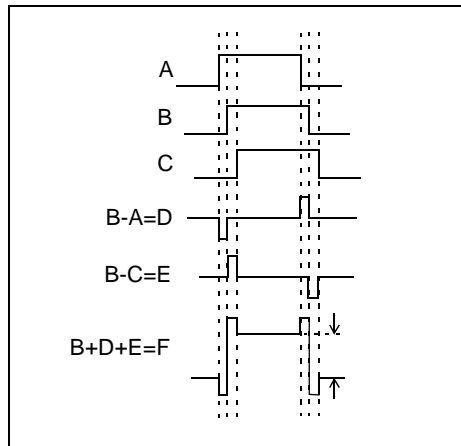
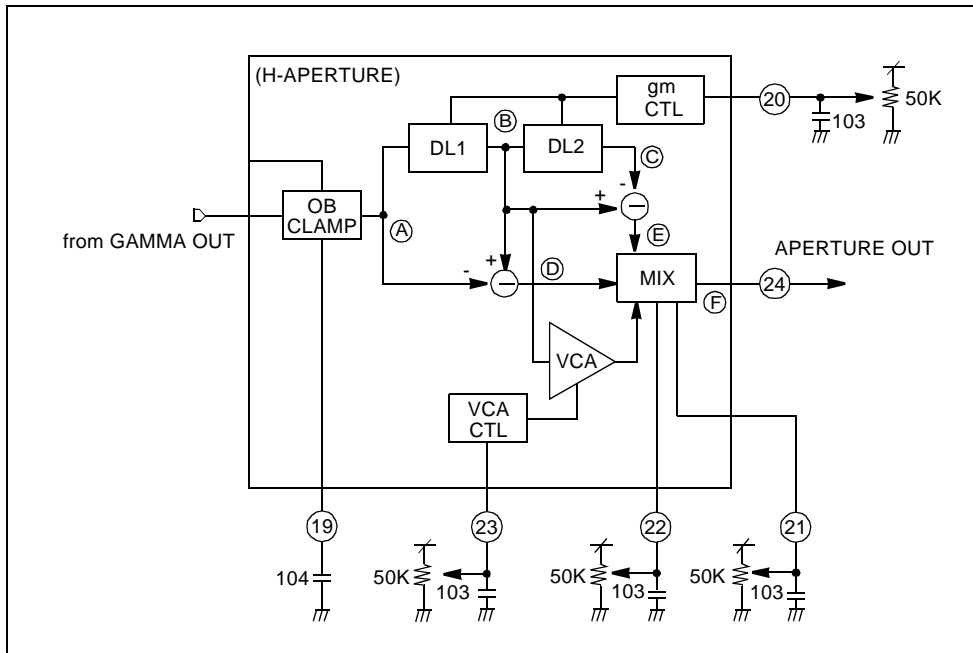
2. OP AMP./COMPARATOR



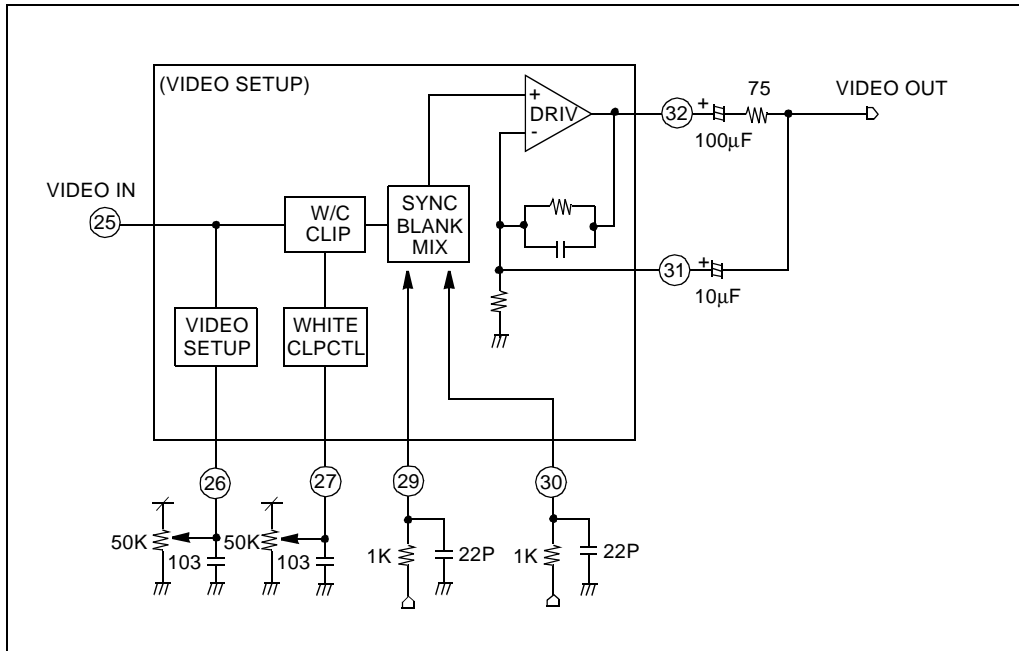
3. GAMMA/Knee/Linear Block



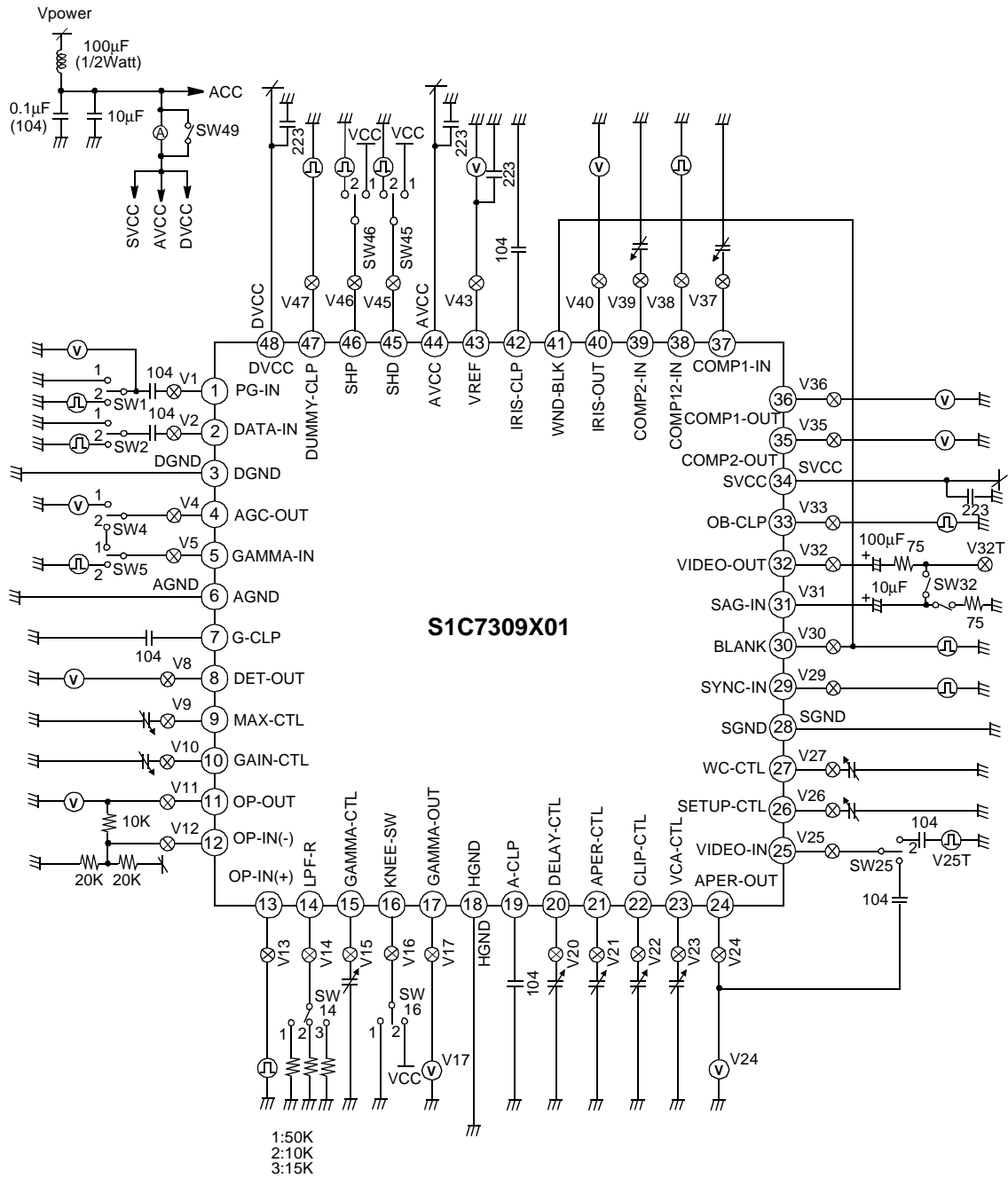
4. Horizontal-Aperture Block

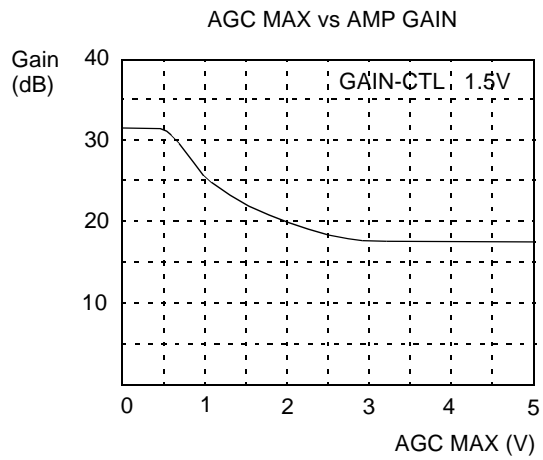
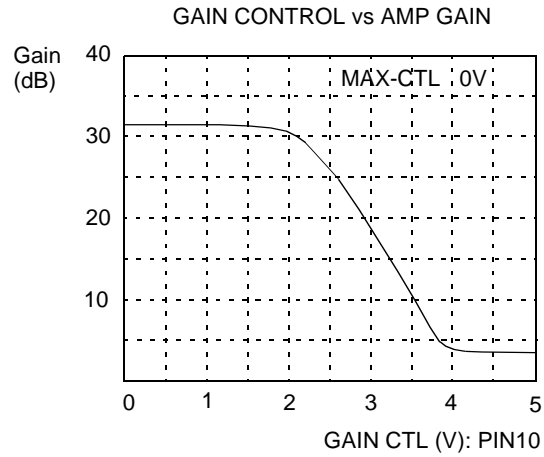


5. VIDEO SETUP/SYNC MIX Block



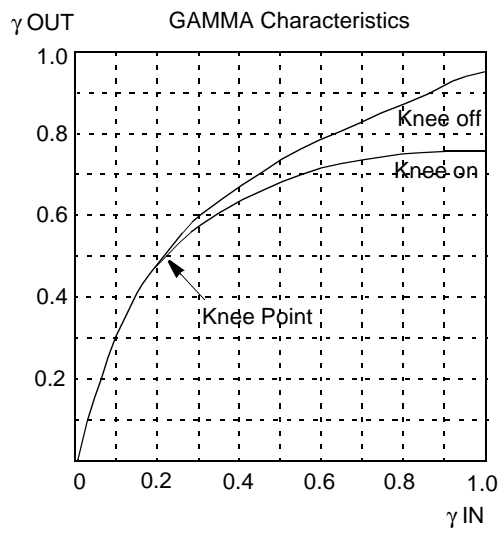
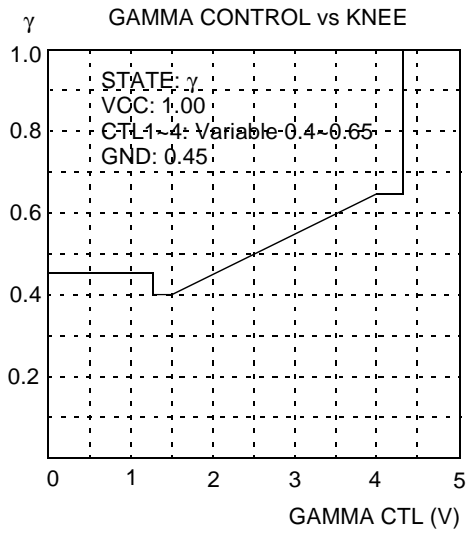
TEST CIRCUIT

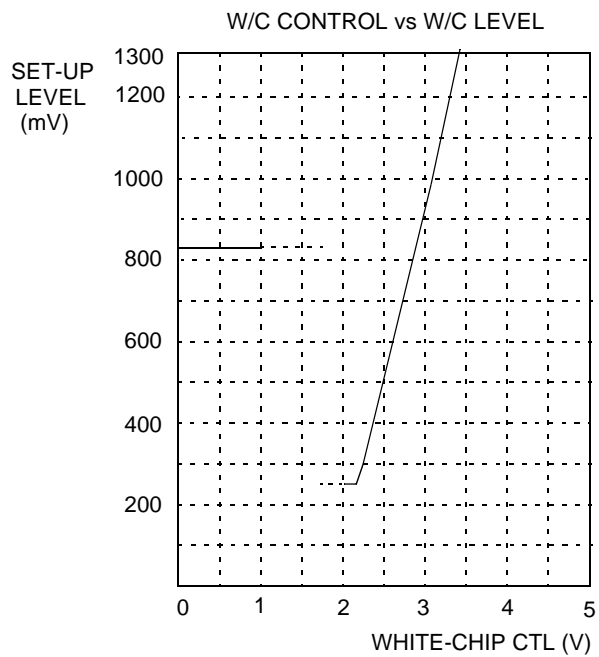
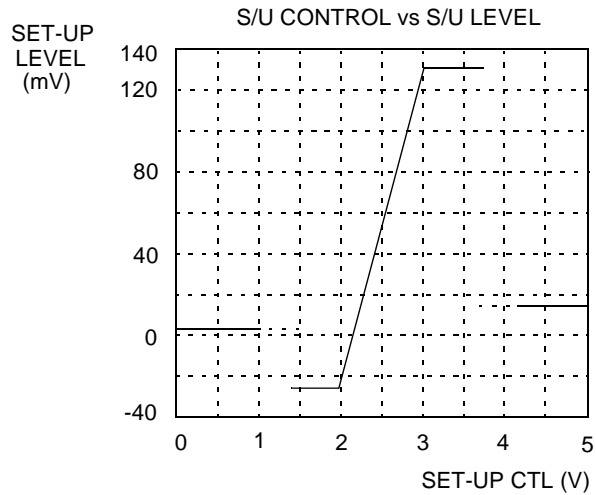


ELECTRICAL CHARACTERISTIC CURVE(STANDARD CHARACTERISTICS; $T_a=25^\circ\text{C}$, $V_{CC}=5\text{V}$)

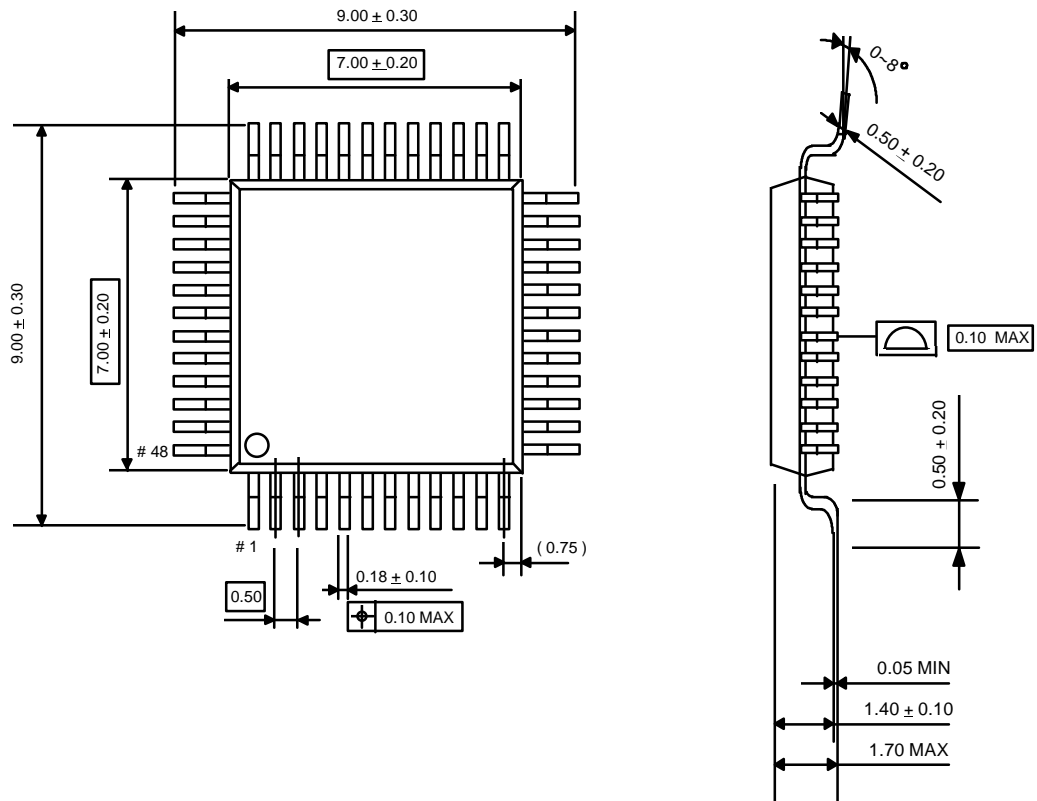
ELECTRICAL CHARACTERISTIC CURVE (Continued)

(STANDARD CHARACTERISTICS; Ta=25°C, V_{CC}=5V)



ELECTRICAL CHARACTERISTIC CURVE (Continued)(STANDARD CHARACTERISTICS; $T_a=25^\circ\text{C}$, $V_{CC}=5\text{V}$)

PACKAGE OUTLINE



48-QFP-0707