

# **S1D15705 Series Technical Manual**

[www.DataSheet4U.com](http://www.DataSheet4U.com)

## NOTICE

---

No part of this material may be reproduced or duplicated in any form or by any means without the written permission of Seiko Epson. Seiko Epson reserves the right to make changes to this material without notice. Seiko Epson does not assume any liability of any kind arising out of any inaccuracies contained in this material or due to its application or use in any product or circuit and, further, there is no representation that this material is applicable to products requiring high level reliability, such as, medical products. Moreover, no license to any intellectual property rights is granted by implication or otherwise, and there is no representation or warranty that anything made in accordance with this material will be free from any patent or copyright infringement of a third party. This material or portions thereof may contain technology or the subject relating to strategic products under the control of the Foreign Exchange and Foreign Trade Law of Japan and may require an export license from the Ministry of International Trade and Industry or other approval from another government agency.

All other product names mentioned herein are trademarks and/or registered trademarks of their respective companies.

# Configuration of product number

●DEVICES

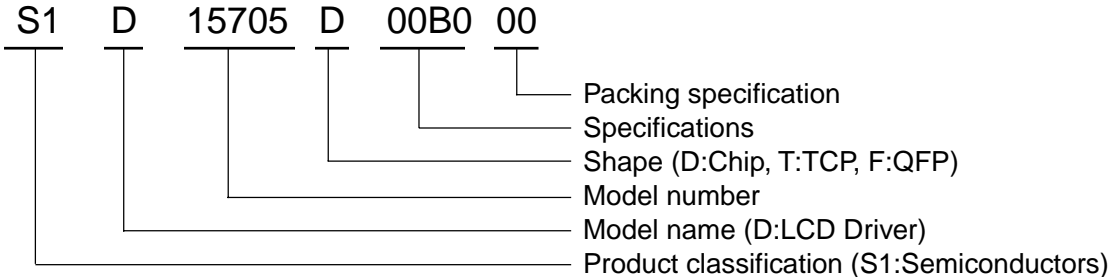

# Contents

1. DESCRIPTION .....	1
2. FEATURES .....	1
3. BLOCK DIAGRAM .....	3
4. PAD .....	4
5. PIN DESCRIPTION .....	14
6. FUNCTION DESCRIPTION .....	18
7. COMMAND .....	38
8. COMMAND SETTING .....	50
9. ABSOLUTE MAXIMUM RATINGS .....	54
10. DC CHARACTERISTICS .....	55
11. MICROPROCESSOR (MPU) INTERFACE: REFERENCE .....	70
12. CONNECTION BETWEEN LCD DRIVERS: REFERENCE .....	71
13. LCD PANEL WIRING: REFERENCE .....	72
14. TCP PIN LAYOUT .....	73
15. TCP DIMENSIONS .....	74
16. TEMPERATURE SENSOR CIRCUIT .....	75
17. CAUTIONS .....	78

www.DataSheet4U.com

## 1. DESCRIPTION

The S1D15705 series is a 1-chip dot matrix liquid crystal driver that can be connected to the bus of a microcomputer. It stores the 8-bit parallel or serial display data sent from the microcomputer in the built-in display data RAM and generates liquid crystal drive signals independently of the microcomputer. Since it incorporates  $65 \times 200$  bits of the display data RAM and the one-dot pixel of the liquid crystal panel and one bit of the built-in RAM have a one-to-one correspondence, it enables display with the high degree of freedom.

The S1D15705 series incorporates 65 circuits of the common output and 168 circuits of the segment output and can display  $65 \times 168$  dots (capable of displaying 10 columns  $\times$  4 rows of a  $16 \times 16$  dot kanji font) using the single chip. The S1D15707 Series incorporates 33 circuits of the common output and 200 circuits of the segment output and can display  $33 \times 200$  dots (capable of displaying 12 columns  $\times$  2 rows of a  $16 \times 16$  dot kanji font). The S1D15708 series incorporates 17 circuits of the common output and 200 circuits of the segment output and can display  $17 \times 200$  dots (capable of displaying 12 columns  $\times$  1 rows of a  $16 \times 16$  dot kanji font). It can also expand the display capacity by using the two chips for the master and slave configuration. Incorporating an analog temperature sensor circuit, the S1D15705\*10\*\* can be used to constitute a system to provide optimum LCD contrast throughout a wide temperature range without need for use of supplementary parts such as the thermistor, under controls of a microcomputer.

Since the read/write operation of the display data RAM does not require external operation clocks, the S1D15705 series can be operated with the minimum current consumption. Since it also incorporates a liquid crystal drive power supply with low current consumption, liquid crystal drive power supply voltage adjusting resistor, and display clock CR oscillator circuit, it can provide a display system for high performance handy equipment with the minimum current consumption and the minimum parts configuration.

## 2. FEATURES

- Direct display of RAM data using the display data RAM  
RAM bit data "1" .... goes on.  
"0" .... goes off (at display normal rotation).
- RAM capacity  
 $65 \times 200 = 13,000$  bits
- Liquid crystal drive circuit  
The S1D15705 Series  
65 circuits for the common output and 168 circuits for the segment output

The S1D15707 Series

33 circuits for the common output and 200 circuits for the segment output

The S1D15708 Series

17 circuits for the common output and 200 circuits for the segment output

- High-speed 8-bit MPU interface (Both the 80 and 68 series MUPs can directly be connected.)/serial interface enabled
- Abundant command functions  
Display Data Read/Write, Display ON/OFF, Display Normal Rotation/Reversal, Page Address Set, Display Start Line Set, column address set, Status Read, Power Supply Save Display All Lighting ON/OFF, LCD Bias Set, Read Modify Write, Segment Driver Direction Select, Electronic Control, V5 Voltage Adjusting Built-in Resistance Ratio Set, Static Indicator, n Line Alternating Current Reversal Drive, Common Output State Selection, and Built-in Oscillator Circuit ON
- Built-in static drive circuit for indicators (One set, blinking speed variable)
- Built-in power supply circuit for low power supply liquid crystal drive  
Booster circuit (Boosting magnification - double, triple, quadruple, boosting reference power supply external input enabled)
- 3% high accuracy alternating current voltage adjusting circuit (Temperature gradient:  $-0.05\%/^{\circ}\text{C}$ )  
Built-in V5 voltage adjusting resistor, built-in V1 to V4 voltage generation split resistors, built-in electronic control function, and voltage follower
- Built-in CR oscillator circuit (external clock input enabled)
- Ultra-low power consumption
- Built-in temperature sensor circuit (S1D15705D10B\*)
- Power supplies  
Logic power supply:  $V_{DD} - V_{SS} = 2.4$  to  $3.6$  V  
(S1D15705\*03\*\*, S1D15707\*03\*\*)  
 $V_{DD} - V_{SS} = 3.6$  to  $5.5$  V  
(S1D15705\*00\*\*, S1D15707\*00\*\*, S1D15708\*00\*\*)  
Boosting reference power supply:  $V_{DD} - V_{SS} = 1.8$  to  $6.0$  V  
Liquid crystal drive power supply:  $V_5 - V_{DD} = -4.5$  to  $-18.0$  V (S1D15705\*\*\*\*\*)  $-4.5$  V to  $-16.0$  V (S1D15707\*\*\*\*\*)  $-4.5$  V to  $-10.0$  (S1D15708\*\*\*\*\*)
- Wide operating temperature range  $-40$  to  $85^{\circ}\text{C}$
- CMOS process
- Shipping form Bare chip, TCP
- No light-resistant and radiation-resistant design are provided.

Series specification

Product name	Voltage [V]	Duty	Bias	SEG Dr	COM Dr	V <sub>REG</sub> temperature gradient	Shipping form
S1D15705D00B*	-3.6 to -5.5	1/65	1/9, 1/7	168	65	-0.05%/°C	Bare chip
S1D15705D10B*	-3.6 to -5.5	1/65	1/9, 1/7	168	65	-0.05%/°C	Bare chip
S1D15705D03B*	-2.4 to -3.6	1/65	1/9, 1/7	168	65	-0.05%/°C	Bare chip
S1D15705T00A*	-3.6 to -5.5	1/65	1/9, 1/7	168	65	-0.05%/°C	TCP
S1D15705T03A*	-2.4 to -3.6	1/65	1/9, 1/7	168	65	-0.05%/°C	TCP
S1D15707D00B*	-3.6 to -5.5	1/33	1/6, 1/5	200	33	-0.05%/°C	Bare chip
S1D15707D03B*	-2.4 to -3.6	1/33	1/6, 1/5	200	33	-0.05%/°C	Bare chip
S1D15707T00**	-3.6 to -5.5	1/33	1/6, 1/5	200	33	-0.05%/°C	TCP
S1D15707T03**	-2.4 to -3.6	1/33	1/6, 1/5	200	33	-0.05%/°C	TCP
S1D15708D00B*	-3.6 to -5.5	1/17	1/6, 1/5	200	17	-0.05%/°C	Bare chip

\*Specifications for circuits other than the temperature sensor circuit are the same as those of the S1D15705D00B\*.

### 3. BLOCK DIAGRAM

Example : S1D15705\*\*\*\*\*

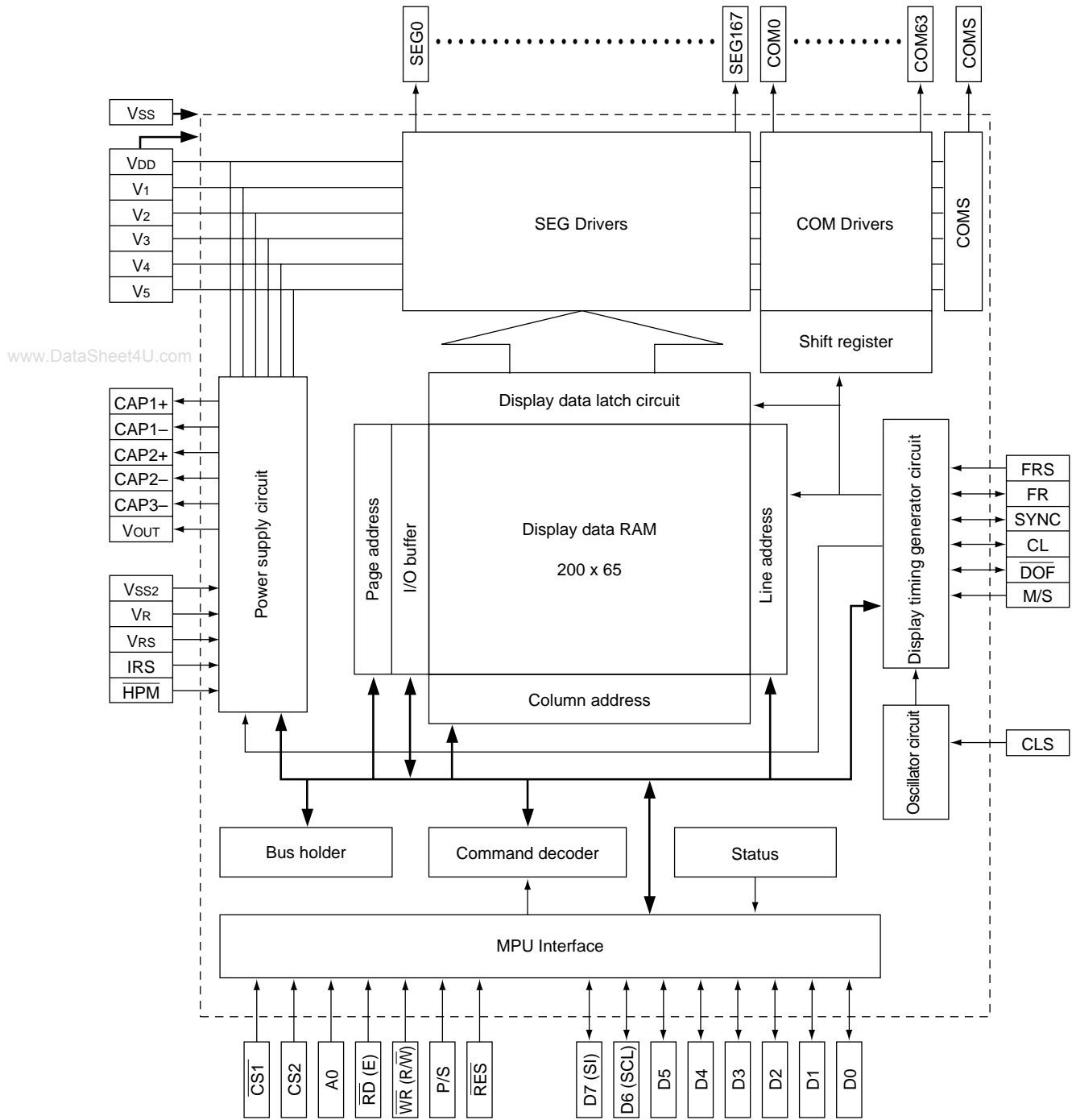

4. PAD  
Pad layout

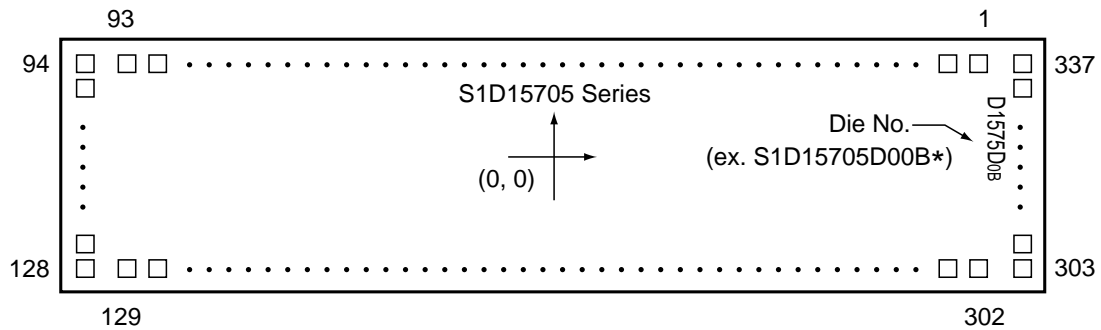

www.DataSheet4U.com

Item	Size			Unit	
	X	Y			
Chip size	13.30	×	2.81	mm	
Chip thickness	0.625			mm	
Bump pitch	71 (Min.)			μm	
Bump size	PAD No.1 to 93	85	×	85	μm
	PAD No.94	85	×	73	μm
	PAD No.95 to 127	85	×	47	μm
	PAD No.128	85	×	73	μm
	PAD No.129	73	×	85	μm
	PAD No.130 to 301	47	×	85	μm
	PAD No.302	73	×	85	μm
	PAD No.303	86	×	73	μm
	PAD No.304 to 336	85	×	47	μm
PAD No.337	85	×	73	μm	
Bump height	17 (Typ.)			μm	



## S1D15705\*\*\*\*\* Pad Central Coordinates

Unit:  $\mu\text{m}$ 

PAD No.	PIN Name	X	Y	PAD No.	PIN Name	X	Y	PAD No.	PIN Name	X	Y
1	(NC)	6195	1246	51	CAP2-	-567	1246	101	COM25	-6474	727
2	(NC)	6059		52	CAP2+	-701		102	COM24		654
3	SYNC	5922		53	CAP2+	-835		103	COM23		581
4	FRS	5786		54	VSS	-969		104	COM22		509
5	FR	5649		55	VSS	-1103		105	COM21		436
6	CL	5513		56	VRS	-1237		106	COM20		363
7	DOF	5376		57	VRS	-1371		107	COM19		291
8	SYNC	5240		58	VDD	-1505		108	COM18		218
9	VSS	5103		59	VDD	-1639		109	COM17		145
10	CS1	4967		60	V1	-1772		110	COM16		73
11	CS2	4830		61	V1	-1906		111	COM15		0
12	VDD	4694		62	V2	-2040		112	COM14		-73
13	RES	4557		63	V2	-2174		113	COM13		-145
14	A0	4421		64	(NC)	-2308		114	COM12		-218
15	VSS	4284		65	V3	-2442		115	COM11		-291
16	WR, R/W	4148		66	V3	-2576		116	COM10		-363
17	RD, E	4011		67	V4	-2710		117	COM9		-436
18	VDD	3875		68	V4	-2844		118	COM8		-509
19	D0	3738		69	V5	-2978		119	COM7		-581
20	D1	3602		70	V5	-3111		120	COM6		-654
21	D2	3465		71	(NC)	-3245		121	COM5		-727
22	D3	3329		72	VR	-3379		122	COM4		-800
23	D4	3192		73	TEST1	-3513		123	COM3		-872
24	D5	3056		74	TEST2	-3647		124	COM2		-945
25	D6 (SCL)	2919		75	TEST3	-3781		125	COM1		-1018
26	D7 (SI)	2783		76	TEST4	-3915		126	COM0		-1090
27	VDD	2646		77	VDD	-4049		127	COMS		-1163
28	VDD	2512		78	M/S	-4185		128	(NC)		-1248
29	VDD	2378		79	CLS	-4322		129	(NC)	-6232	-1246
30	VDD	2245		80	VSS	-4458		130	(NC)	-6147	
31	VDD	2111		81	C86	-4595		131	(NC)	-6075	
32	VSS	1977		82	P/S	-4731		132	SEG0	-6002	
33	VSS	1843		83	VDD	-4868		133	SEG1	-5930	
34	VSS	1709		84	HPM	-5004		134	SEG2	-5859	
35	VSS2	1575		85	VSS	-5141		135	SEG3	-5787	
36	VSS2	1441		86	IRS	-5277		136	SEG4	-5715	
37	VSS2	1307		87	VDD	-5414		137	SEG5	-5643	
38	VSS2	1173		88	TEST5	-5550		138	SEG6	-5571	
39	VSS2	1039		89	TEST6	-5687		139	SEG7	-5499	
40	(NC)	906		90	TEST7	-5836		140	SEG8	-5427	
41	VOUT	772		91	TEST8	-5956		141	SEG9	-5355	
42	VOUT	638		92	TEST9	-6076		142	SEG10	-5283	
43	CAP3-	504		93	(NC)	-6195		143	SEG11	-5212	
44	CAP3-	370		94	(NC)	-6474	1248	144	SEG12	-5140	
45	(NC)	236		95	COM31		1163	145	SEG13	-5068	
46	CAP1+	102		96	COM30		1090	146	SEG14	-4996	
47	CAP1+	-32		97	COM29		1017	147	SEG15	-4924	
48	CAP1-	-166		98	COM28		945	148	SEG16	-4852	
49	CAP1-	-300		99	COM27		872	149	SEG17	-4780	
50	CAP2-	-433		100	COM26		799	150	SEG18	-4708	

Unit:  $\mu\text{m}$

PAD No.	PIN Name	X	Y	PAD No.	PIN Name	X	Y	PAD No.	PIN Name	X	Y
151	SEG19	-4636	-1246	201	SEG69	-1042	-1246	251	SEG119	2553	-1246
152	SEG20	-4564		202	SEG70	-970		252	SEG120	2625	
153	SEG21	-4493		203	SEG71	-898		253	SEG121	2696	
154	SEG22	-4421		204	SEG72	-826		254	SEG122	2768	
155	SEG23	-4349		205	SEG73	-754		255	SEG123	2840	
156	SEG24	-4277		206	SEG74	-682		256	SEG124	2912	
157	SEG25	-4205		207	SEG75	-611		257	SEG125	2984	
158	SEG26	-4133		208	SEG76	-539		258	SEG126	3056	
159	SEG27	-4061		209	SEG77	-467		259	SEG127	3128	
160	SEG28	-3989		210	SEG78	-395		260	SEG128	3200	
161	SEG29	-3917		211	SEG79	-323		261	SEG129	3272	
162	SEG30	-3846		212	SEG80	-251		262	SEG130	3343	
163	SEG31	-3774		213	SEG81	-179		263	SEG131	3415	
164	SEG32	-3702		214	SEG82	-107		264	SEG132	3487	
165	SEG33	-3630		215	SEG83	-35		265	SEG133	3559	
166	SEG34	-3558		216	SEG84	36		266	SEG134	3631	
167	SEG35	-3486		217	SEG85	108		267	SEG135	3703	
168	SEG36	-3414		218	SEG86	180		268	SEG136	3775	
169	SEG37	-3342		219	SEG87	252		269	SEG137	3847	
170	SEG38	-3270		220	SEG88	324		270	SEG138	3919	
171	SEG39	-3199		221	SEG89	396		271	SEG139	3990	
172	SEG40	-3127		222	SEG90	468		272	SEG140	4062	
173	SEG41	-3055		223	SEG91	540		273	SEG141	4134	
174	SEG42	-2983		224	SEG92	612		274	SEG142	4206	
175	SEG43	-2911		225	SEG93	683		275	SEG143	4278	
176	SEG44	-2839		226	SEG94	755		276	SEG144	4350	
177	SEG45	-2767		227	SEG95	827		277	SEG145	4422	
178	SEG46	-2695		228	SEG96	899		278	SEG146	4494	
179	SEG47	-2623		229	SEG97	971		279	SEG147	4566	
180	SEG48	-2552		230	SEG98	1043		280	SEG148	4637	
181	SEG49	-2480		231	SEG99	1115		281	SEG149	4709	
182	SEG50	-2408		232	SEG100	1187		282	SEG150	4781	
183	SEG51	-2336		233	SEG101	1259		283	SEG151	4853	
184	SEG52	-2264		234	SEG102	1330		284	SEG152	4925	
185	SEG53	-2192		235	SEG103	1402		285	SEG153	4997	
186	SEG54	-2120		236	SEG104	1474		286	SEG154	5069	
187	SEG55	-2048		237	SEG105	1546		287	SEG155	5141	
188	SEG56	-1976		238	SEG106	1618		288	SEG156	5213	
189	SEG57	-1905		239	SEG107	1690		289	SEG157	5284	
190	SEG58	-1833		240	SEG108	1762		290	SEG158	5356	
191	SEG59	-1761		241	SEG109	1834		291	SEG159	5428	
192	SEG60	-1689		242	SEG110	1906		292	SEG160	5500	
193	SEG61	-1617		243	SEG111	1977		293	SEG161	5572	
194	SEG62	-1545		244	SEG112	2049		294	SEG162	5644	
195	SEG63	-1473		245	SEG113	2121		295	SEG163	5716	
196	SEG64	-1401		246	SEG114	2193		296	SEG164	5788	
197	SEG65	-1329		247	SEG115	2265		297	SEG165	5860	
198	SEG66	-1258		248	SEG116	2337		298	SEG166	5931	
199	SEG67	-1186		249	SEG117	2409		299	SEG167	6003	
200	SEG68	-1114	▼	250	SEG118	2481	▼	300	(NC)	6075	▼

Unit:  $\mu\text{m}$

PAD No.	PIN Name	X	Y
301	(NC)	6147	-1246
302	(NC)	6232	↓
303	(NC)	6474	-1248
304	COM32	↓	-1163
305	COM33		-1090
306	COM34		-1018
307	COM35		-945
308	COM36		-872
309	COM37		-800
310	COM38		-727
311	COM39		-654
312	COM40		-581
313	COM41		-509
314	COM42		-436
315	COM43		-363
316	COM44		-291
317	COM45		-218
318	COM46		-145
319	COM47		-73
320	COM48		0
321	COM49		73
322	COM50		145
323	COM51		218
324	COM52		291
325	COM53		363
326	COM54		436
327	COM55		509
328	COM56		581
329	COM57		654
330	COM58		727
331	COM59		799
332	COM60		872
333	COM61		945
334	COM62		1017
335	COM63		1090
336	COMS		1163
337	(NC)	↓	1248

S1D15707\*\*\*\*\* Pad Central Coordinates

Unit:  $\mu\text{m}$

PAD No.	PIN Name	X	Y	PAD No.	PIN Name	X	Y	PAD No.	PIN Name	X	Y
1	(NC)	6195	1246	51	CAP2-	-567	1246	101	COM25	-6474	727
2	(NC)	6059		52	CAP2+	-701		102	COM24		654
3	SYNC	5922		53	CAP2+	-835		103	COM23		581
4	FRS	5786		54	VSS	-969		104	COM22		509
5	FR	5649		55	VSS	-1103		105	COM21		436
6	CL	5513		56	VRS	-1237		106	COM20		363
7	DOF	5376		57	VRS	-1371		107	COM19		291
8	SYNC	5240		58	VDD	-1505		108	COM18		218
9	VSS	5103		59	VDD	-1639		109	COM17		145
10	CS1	4967		60	V1	-1772		110	COM16		73
11	CS2	4830		61	V1	-1906		111	COM15		0
12	VDD	4694		62	V2	-2040		112	COM14		-73
13	RES	4557		63	V2	-2174		113	COM13		-145
14	A0	4421		64	(NC)	-2308		114	COM12		-218
15	VSS	4284		65	V3	-2442		115	COM11		-291
16	WR, R/W	4148		66	V3	-2576		116	COM10		-363
17	RD, E	4011		67	V4	-2710		117	COM9		-436
18	VDD	3875		68	V4	-2844		118	COM8		-509
19	D0	3738		69	V5	-2978		119	COM7		-581
20	D1	3602		70	V5	-3111		120	COM6		-654
21	D2	3465		71	(NC)	-3245		121	COM5		-727
22	D3	3329		72	VR	-3379		122	COM4		-800
23	D4	3192		73	TEST1	-3513		123	COM3		-872
24	D5	3056		74	TEST2	-3647		124	COM2		-945
25	D6 (SCL)	2919		75	TEST3	-3781		125	COM1		-1018
26	D7 (SI)	2783		76	TEST4	-3915		126	COM0		-1090
27	VDD	2646		77	VDD	-4049		127	COMS		-1163
28	VDD	2512		78	M/S	-4185		128	(NC)		-1248
29	VDD	2378		79	CLS	-4322		129	(NC)	-6232	-1246
30	VDD	2245		80	VSS	-4458		130	(NC)	-6147	
31	VDD	2111		81	C86	-4595		131	(NC)	-6075	
32	VSS	1977		82	P/S	-4731		132	SEG0	-6002	
33	VSS	1843		83	VDD	-4868		133	SEG1	-5930	
34	VSS	1709		84	HPM	-5004		134	SEG2	-5859	
35	VSS2	1575		85	VSS	-5141		135	SEG3	-5787	
36	VSS2	1441		86	IRS	-5277		136	SEG4	-5715	
37	VSS2	1307		87	VDD	-5414		137	SEG5	-5643	
38	VSS2	1173		88	TEST5	-5550		138	SEG6	-5571	
39	VSS2	1039		89	TEST6	-5687		139	SEG7	-5499	
40	(NC)	906		90	TEST7	-5836		140	SEG8	-5427	
41	VOUT	772		91	TEST8	-5956		141	SEG9	-5355	
42	VOUT	638		92	TEST9	-6076		142	SEG10	-5283	
43	CAP3-	504		93	(NC)	-6195		143	SEG11	-5212	
44	CAP3-	370		94	(NC)	-6474	1248	144	SEG12	-5140	
45	(NC)	236		95	COM31		1163	145	SEG13	-5068	
46	CAP1+	102		96	COM30		1090	146	SEG14	-4996	
47	CAP1+	-32		97	COM29		1017	147	SEG15	-4924	
48	CAP1-	-166		98	COM28		945	148	SEG16	-4852	
49	CAP1-	-300		99	COM27		872	149	SEG17	-4780	
50	CAP2-	-433		100	COM26		799	150	SEG18	-4708	

Unit:  $\mu\text{m}$ 

PAD No.	PIN Name	X	Y	PAD No.	PIN Name	X	Y	PAD No.	PIN Name	X	Y
151	SEG19	-4636	-1246	201	SEG69	-1042	-1246	251	SEG119	2553	-1246
152	SEG20	-4564		202	SEG70	-970		252	SEG120	2625	
153	SEG21	-4493		203	SEG71	-898		253	SEG121	2696	
154	SEG22	-4421		204	SEG72	-826		254	SEG122	2768	
155	SEG23	-4349		205	SEG73	-754		255	SEG123	2840	
156	SEG24	-4277		206	SEG74	-682		256	SEG124	2912	
157	SEG25	-4205		207	SEG75	-611		257	SEG125	2984	
158	SEG26	-4133		208	SEG76	-539		258	SEG126	3056	
159	SEG27	-4061		209	SEG77	-467		259	SEG127	3128	
160	SEG28	-3989		210	SEG78	-395		260	SEG128	3200	
161	SEG29	-3917		211	SEG79	-323		261	SEG129	3272	
162	SEG30	-3846		212	SEG80	-251		262	SEG130	3343	
163	SEG31	-3774		213	SEG81	-179		263	SEG131	3415	
164	SEG32	-3702		214	SEG82	-107		264	SEG132	3487	
165	SEG33	-3630		215	SEG83	-35		265	SEG133	3559	
166	SEG34	-3558		216	SEG84	36		266	SEG134	3631	
167	SEG35	-3486		217	SEG85	108		267	SEG135	3703	
168	SEG36	-3414		218	SEG86	180		268	SEG136	3775	
169	SEG37	-3342		219	SEG87	252		269	SEG137	3847	
170	SEG38	-3270		220	SEG88	324		270	SEG138	3919	
171	SEG39	-3199		221	SEG89	396		271	SEG139	3990	
172	SEG40	-3127		222	SEG90	468		272	SEG140	4062	
173	SEG41	-3055		223	SEG91	540		273	SEG141	4134	
174	SEG42	-2983		224	SEG92	612		274	SEG142	4206	
175	SEG43	-2911		225	SEG93	683		275	SEG143	4278	
176	SEG44	-2839		226	SEG94	755		276	SEG144	4350	
177	SEG45	-2767		227	SEG95	827		277	SEG145	4422	
178	SEG46	-2695		228	SEG96	899		278	SEG146	4494	
179	SEG47	-2623		229	SEG97	971		279	SEG147	4566	
180	SEG48	-2552		230	SEG98	1043		280	SEG148	4637	
181	SEG49	-2480		231	SEG99	1115		281	SEG149	4709	
182	SEG50	-2408		232	SEG100	1187		282	SEG150	4781	
183	SEG51	-2336		233	SEG101	1259		283	SEG151	4853	
184	SEG52	-2264		234	SEG102	1330		284	SEG152	4925	
185	SEG53	-2192		235	SEG103	1402		285	SEG153	4997	
186	SEG54	-2120		236	SEG104	1474		286	SEG154	5069	
187	SEG55	-2048		237	SEG105	1546		287	SEG155	5141	
188	SEG56	-1976		238	SEG106	1618		288	SEG156	5213	
189	SEG57	-1905		239	SEG107	1690		289	SEG157	5284	
190	SEG58	-1833		240	SEG108	1762		290	SEG158	5356	
191	SEG59	-1761		241	SEG109	1834		291	SEG159	5428	
192	SEG60	-1689		242	SEG110	1906		292	SEG160	5500	
193	SEG61	-1617		243	SEG111	1977		293	SEG161	5572	
194	SEG62	-1545		244	SEG112	2049		294	SEG162	5644	
195	SEG63	-1473		245	SEG113	2121		295	SEG163	5716	
196	SEG64	-1401		246	SEG114	2193		296	SEG164	5788	
197	SEG65	-1329		247	SEG115	2265		297	SEG165	5860	
198	SEG66	-1258		248	SEG116	2337		298	SEG166	5931	
199	SEG67	-1186		249	SEG117	2409		299	SEG167	6003	
200	SEG68	-1114	▼	250	SEG118	2481	▼	300	(NC)	6075	▼

Unit:  $\mu\text{m}$

PAD No.	PIN Name	X	Y
301	(NC)	6147	-1246
302	(NC)	6232	↓
303	(NC)	6474	-1248
304	SEG168	↓	-1163
305	SEG169		-1090
306	SEG170		-1018
307	SEG171		-945
308	SEG172		-872
309	SEG173		-800
310	SEG174		-727
311	SEG175		-654
312	SEG176		-581
313	SEG177		-509
314	SEG178		-436
315	SEG179		-363
316	SEG180		-291
317	SEG181		-218
318	SEG182		-145
319	SEG183		-73
320	SEG184		0
321	SEG185		73
322	SEG186		145
323	SEG187		218
324	SEG188		291
325	SEG189		363
326	SEG190		436
327	SEG191		509
328	SEG192		581
329	SEG193		654
330	SEG194		727
331	SEG195		799
332	SEG196		872
333	SEG197		945
334	SEG198		1017
335	SEG199		1090
336	COMS		1163
337	(NC)	↓	1248

## S1D15708\*\*\*\*\* Pad Central Coordinates

Unit:  $\mu\text{m}$ 

PAD No.	PIN Name	X	Y	PAD No.	PIN Name	X	Y	PAD No.	PIN Name	X	Y
1	(NC)	6159	1246	51	CAP2-	-567	1246	101	COM12	-6474	727
2	(NC)	6059		52	CAP2+	-701		102	COM12		654
3	SYNC	5922		53	CAP2+	-835		103	COM11		581
4	FRS	5786		54	Vss	-969		104	COM11		509
5	FR	5649		55	Vss	-1103		105	COM10		436
6	CL	5513		56	Vrs	-1237		106	COM10		363
7	DOF	5376		57	Vrs	-1371		107	COM9		291
8	SYNC	5240		58	VDD	-1505		108	COM9		218
9	Vss	5103		59	VDD	-1639		109	COM8		145
10	CS1	4967		60	V1	-1772		110	COM8		73
11	CS2	4830		61	V1	-1906		111	COM7		0
12	VDD	4694		62	V2	-2040		112	COM7		-73
13	RES	4557		63	V2	-2174		113	COM6		-145
14	A0	4421		64	(NC)	-2308		114	COM6		-218
15	Vss	4284		65	V3	-2442		115	COM5		-291
16	WR, R/W	4148		66	V3	-2576		116	COM5		-363
17	RD, E	4011		67	V4	-2710		117	COM4		-436
18	VDD	3875		68	V4	-2844		118	COM4		-509
19	D0	3738		69	V5	-2978		119	COM3		-581
20	D1	3602		70	V5	-3111		120	COM3		-654
21	D2	3465		71	(NC)	-3245		121	COM2		-727
22	D3	3329		72	VR	-3379		122	COM2		-800
23	D4	3192		73	TEST1	-3513		123	COM1		-872
24	D5	3056		74	TEST2	-3647		124	COM1		-945
25	D6 (SCL)	2919		75	TEST3	-3781		125	COM0		-1018
26	D7 (SI)	2783		76	TEST4	-3915		126	COM0		-1090
27	VDD	2646		77	VDD	-4049		127	COMS		-1163
28	VDD	2512		78	M/S	-4185		128	(NC)		-1248
29	VDD	2378		79	CLS	-4322		129	(NC)	-6232	-1246
30	VDD	2245		80	Vss	-4458		130	(NC)	-6147	
31	VDD	2111		81	C86	-4595		131	(NC)	-6075	
32	Vss	1977		82	P/S	-4731		132	SEG0	-6002	
33	Vss	1843		83	VDD	-4868		133	SEG1	-5930	
34	Vss	1709		84	HPM	-5004		134	SEG2	-5859	
35	Vss2	1575		85	Vss	-5141		135	SEG3	-5787	
36	Vss2	1441		86	IRS	-5277		136	SEG4	-5715	
37	Vss2	1307		87	VDD	-5414		137	SEG5	-5643	
38	Vss2	1173		88	TEST5	-5550		138	SEG6	-5571	
39	Vss2	1039		89	TEST6	-5687		139	SEG7	-5499	
40	(NC)	906		90	TEST7	-5836		140	SEG8	-5427	
41	VOUT	772		91	TEST8	-5956		141	SEG9	-5355	
42	VOUT	638		92	TEST9	-6076		142	SEG10	-5283	
43	CAP3-	504		93	(NC)	-6195		143	SEG11	-5212	
44	CAP3-	370		94	(NC)	-6474	1248	144	SEG12	-5140	
45	(NC)	236		95	COM15		1163	145	SEG13	-5068	
46	CAP1+	102		96	COM15		1090	146	SEG14	-4996	
47	CAP1+	-32		97	COM14		1017	147	SEG15	-4924	
48	CAP1-	-166		98	COM14		945	148	SEG16	-4852	
49	CAP1-	-300		99	COM13		872	149	SEG17	-4780	
50	CAP2-	-433		100	COM13		799	150	SEG18	-4708	

PAD No.	PIN Name	X	Y	PAD No.	PIN Name	X	Y	PAD No.	PIN Name	X	Y
151	SEG19	-4636	-1246	201	SEG69	-1042	-1246	251	SEG119	2553	-1246
152	SEG20	-4564		202	SEG70	-970		252	SEG120	2625	
153	SEG21	-4493		203	SEG71	-898		253	SEG121	2696	
154	SEG22	-4421		204	SEG72	-826		254	SEG122	2768	
155	SEG23	-4349		205	SEG73	-754		255	SEG123	2840	
156	SEG24	-4277		206	SEG74	-682		256	SEG124	2912	
157	SEG25	-4205		207	SEG75	-611		257	SEG125	2984	
158	SEG26	-4133		208	SEG76	-539		258	SEG126	3056	
159	SEG27	-4061		209	SEG77	-467		259	SEG127	3128	
160	SEG28	-3989		210	SEG78	-395		260	SEG128	3200	
161	SEG29	-3917		211	SEG79	-323		261	SEG129	3272	
162	SEG30	-3846		212	SEG80	-251		262	SEG130	3343	
163	SEG31	-3774		213	SEG81	-179		263	SEG131	3415	
164	SEG32	-3702		214	SEG82	-107		264	SEG132	3487	
165	SEG33	-3630		215	SEG83	-35		265	SEG133	3559	
166	SEG34	-3558		216	SEG84	36		266	SEG134	3631	
167	SEG35	-3486		217	SEG85	108		267	SEG135	3703	
168	SEG36	-3414		218	SEG86	180		268	SEG136	3775	
169	SEG37	-3342		219	SEG87	252		269	SEG137	3847	
170	SEG38	-3270		220	SEG88	324		270	SEG138	3919	
171	SEG39	-3199		221	SEG89	396		271	SEG139	3990	
172	SEG40	-3127		222	SEG90	468		272	SEG140	4062	
173	SEG41	-3055		223	SEG91	540		273	SEG141	4134	
174	SEG42	-2983		224	SEG92	612		274	SEG142	4206	
175	SEG43	-2911		225	SEG93	683		275	SEG143	4278	
176	SEG44	-2839		226	SEG94	755		276	SEG144	4350	
177	SEG45	-2767		227	SEG95	827		277	SEG145	4422	
178	SEG46	-2695		228	SEG96	899		278	SEG146	4494	
179	SEG47	-2623		229	SEG97	971		279	SEG147	4566	
180	SEG48	-2552		230	SEG98	1043		280	SEG148	4637	
181	SEG49	-2480		231	SEG99	1115		281	SEG149	4709	
182	SEG50	-2408		232	SEG100	1187		282	SEG150	4781	
183	SEG51	-2336		233	SEG101	1259		283	SEG151	4853	
184	SEG52	-2264		234	SEG102	1330		284	SEG152	4925	
185	SEG53	-2192		235	SEG103	1402		285	SEG153	4997	
186	SEG54	-2120		236	SEG104	1474		286	SEG154	5069	
187	SEG55	-2048		237	SEG105	1546		287	SEG155	5141	
188	SEG56	-1976		238	SEG106	1618		288	SEG156	5213	
189	SEG57	-1905		239	SEG107	1690		289	SEG157	5284	
190	SEG58	-1833		240	SEG108	1762		290	SEG158	5356	
191	SEG59	-1761		241	SEG109	1834		291	SEG159	5428	
192	SEG60	-1689		242	SEG110	1906		292	SEG160	5500	
193	SEG61	-1617		243	SEG111	1977		293	SEG161	5572	
194	SEG62	-1545		244	SEG112	2049		294	SEG162	5644	
195	SEG63	-1473		245	SEG113	2121		295	SEG163	5716	
196	SEG64	-1401		246	SEG114	2193		296	SEG164	5788	
197	SEG65	-1329		247	SEG115	2265		297	SEG165	5860	
198	SEG66	-1258		248	SEG116	2337		298	SEG166	5931	
199	SEG67	-1186		249	SEG117	2409		299	SEG167	6003	
200	SEG68	-1114	↓	250	SEG118	2481	↓	300	(NC)	6075	↓



Unit:  $\mu\text{m}$

PAD No.	PIN Name	X	Y
301	(NC)	6147	-1246
302	(NC)	6232	↓
303	(NC)	6474	-1248
304	SEG168	↓	-1163
305	SEG169		-1090
306	SEG170		-1018
307	SEG171		-945
308	SEG172		-872
309	SEG173		-800
310	SEG174		-727
311	SEG175		-654
312	SEG176		-581
313	SEG177		-509
314	SEG178		-436
315	SEG179		-363
316	SEG180		-291
317	SEG181		-218
318	SEG182		-145
319	SEG183		-73
320	SEG184		0
321	SEG185		73
322	SEG186		145
323	SEG187		218
324	SEG188		291
325	SEG189		363
326	SEG190		436
327	SEG191		509
328	SEG192		581
329	SEG193		654
330	SEG194		727
331	SEG195		799
332	SEG196		872
333	SEG197		945
334	SEG198		1017
335	SEG199		1090
336	COMS		1163
337	(NC)	↓	1248

## 5. PIN DESCRIPTION

### Power Supply Pin

Pin name	I/O	Description	Number of pins																									
VDD	Power supply	Commonly used with the MPU power supply pin Vcc.	12																									
VSS	Power supply	0 V pin connected to the system ground (GND).	9																									
VSS2	Power supply	Boosting circuit reference power supply for liquid crystal drive.	5																									
VRS	Power supply	External input pin for liquid crystal power supply voltage adjusting circuit. They are set to OPEN.	2																									
V1, V2 V3, V4 V5	Power supply	<p>Multi-level power supply for liquid crystal drive. The voltage specified according to liquid crystal cells is impedance-converted by a split resistor or operation amplifier (OP amp) and applied. The potential needs to be specified based on VDD to establish the relationship of dimensions shown below:</p> $V_{DD} (=V_0) \geq V_1 \geq V_2 \geq V_3 \geq V_4 \geq V_5$ <p>Master operation When the power supply is ON, the following voltages are applied to V1 to V4 from the built-in power supply circuit. The selection of the voltages is determined using the LCD bias set command.</p> <table border="1" style="margin-left: auto; margin-right: auto;"> <thead> <tr> <th></th> <th colspan="2">S1D15705***</th> <th colspan="2">S1D15707***, S1D15708***</th> </tr> </thead> <tbody> <tr> <td>V1</td> <td>1/9•V5</td> <td>1/7•V5</td> <td>1/6•V5</td> <td>1/5•V5</td> </tr> <tr> <td>V2</td> <td>2/9•V5</td> <td>2/7•V5</td> <td>2/6•V5</td> <td>2/5•V5</td> </tr> <tr> <td>V3</td> <td>7/9•V5</td> <td>5/7•V5</td> <td>4/6•V5</td> <td>3/5•V5</td> </tr> <tr> <td>V4</td> <td>8/9•V5</td> <td>6/7•V5</td> <td>5/6•V5</td> <td>4/5•V5</td> </tr> </tbody> </table>		S1D15705***		S1D15707***, S1D15708***		V1	1/9•V5	1/7•V5	1/6•V5	1/5•V5	V2	2/9•V5	2/7•V5	2/6•V5	2/5•V5	V3	7/9•V5	5/7•V5	4/6•V5	3/5•V5	V4	8/9•V5	6/7•V5	5/6•V5	4/5•V5	10
	S1D15705***		S1D15707***, S1D15708***																									
V1	1/9•V5	1/7•V5	1/6•V5	1/5•V5																								
V2	2/9•V5	2/7•V5	2/6•V5	2/5•V5																								
V3	7/9•V5	5/7•V5	4/6•V5	3/5•V5																								
V4	8/9•V5	6/7•V5	5/6•V5	4/5•V5																								

### LCD Power Supply Circuit Pin

Pin name	I/O	Description	Number of pins
CAP1+	O	Boosting capacitor positive side connecting pin. Connects a capacitor between the pin and CAP1– pin.	2
CAP1–	O	Boosting capacitor negative side connecting pin. Connects a capacitor between the pin and CAP1+ pin.	2
CAP2+	O	Boosting capacitor positive side connecting pin. Connects a capacitor between the pin and CAP2– pin.	2
CAP2–	O	Boosting capacitor negative side connecting pin. Connects a capacitor between the pin and CAP2+ pin.	2
CAP3–	O	Boosting capacitor negative side connecting pin. Connects a capacitor between the pin and CAP1+ pin.	2
VOUT	O	Boosting output pin. Connects a capacitor between the pin and VSS2.	2
VR	I	<p>Voltage adjusting pin. Applies voltage between VDD and V5 using a split resistor.</p> <p>Valid only when the V5 voltage adjusting built-in resistor is not used (IRS=LOW) Do not use VR when the V5 voltage adjusting built-in resistor is used (IRS=HIGH)</p>	1

## System Bus Connecting Pins

Pin name	I/O	Description	Number of pins															
D7 to D0 (SI) (SCL)	I/O	An 8-bit bidirectional data bus is used to connect an 8-bit or 16-bit standard MPU data bus. When the serial interface is selected (P/S=LOW), D7: Serial data entry pin (SI) D6: Serial clock input pin (SCL) In this case, D0 to D5 are set to high impedance. When Chip Select is in the non-active state, D0 to D7 are set to high impedance.	8															
A0	I	Normally the lowest order bit of the MPU address bus is connected to discriminate data / commands. A0=HIGH: Indicates that D0 to D7 are display data. A0=LOW: Indicates that D0 to D7 are control data.	1															
RES	I	Initialized by setting $\overline{\text{RES}}$ to LOW. Reset operation is performed at the $\overline{\text{RES}}$ signal level.	1															
$\overline{\text{CS1}}$ $\overline{\text{CS2}}$	I	Chip Select signal. When $\overline{\text{CS1}}$ =LOW and $\overline{\text{CS2}}$ =HIGH, this signal becomes active and the input/output of data/commands is enabled.	2															
$\overline{\text{RD}}$ (E)	I	<ul style="list-style-type: none"> <li>When the 80 series MPU is connected, active LOW is set. Pin that connects the <math>\overline{\text{RD}}</math> signal of the 80 series MPU. When this signal is LOW, the S1D15705 series data bus is set in the output state.</li> <li>When the 68 series MPU is connected, active HIGH is set. 68 series MPU enable clock input pin</li> </ul>	1															
$\overline{\text{WR}}$ (R/W)	I	<ul style="list-style-type: none"> <li>When the 80 series MPU is connected, active LOW is set. Pin that connects the <math>\overline{\text{WR}}</math> signal of the 80 series MPU. The data bus signal is latched on the leading edge of the <math>\overline{\text{WR}}</math> signal.</li> <li>When the 68 series MPU is connected, Read/write control signal input pin R/W=HIGH: Read operation R/W=LOW: Write operation</li> </ul>	1															
FRS	O	Output pin for static drive Used together with the SYNC pin	1															
C86	I	MPU interface switching pin C86=HIGH: 68 series MPU interface C86=LOW: 80 series MPU interface	1															
P/S	I	<p>Switching pin for parallel data entry/serial data entry P/S=HIGH: Parallel data entry P/S=LOW: Serial data entry According to the P/S state, the following table is given.</p> <table border="1" style="margin-left: auto; margin-right: auto;"> <thead> <tr> <th>P/S</th> <th>Data/ command</th> <th>Data</th> <th>Read/write</th> <th>Serial clock</th> </tr> </thead> <tbody> <tr> <td>HIGH</td> <td>A0</td> <td>D0 to D7</td> <td><math>\overline{\text{RD}}</math>, <math>\overline{\text{WR}}</math></td> <td></td> </tr> <tr> <td>LOW</td> <td>A0</td> <td>SI (D7)</td> <td>Write-only</td> <td>SCL (D6)</td> </tr> </tbody> </table> <p>When P/S=LOW, D0 to D5 are set to high impedance. D0 to D5 can be HIGH, LOW, or "OPEN". RD(E) and WR (R/W) are fixed to HIGH or LOW. For the serial data entry, RAM display data cannot be read.</p>	P/S	Data/ command	Data	Read/write	Serial clock	HIGH	A0	D0 to D7	$\overline{\text{RD}}$ , $\overline{\text{WR}}$		LOW	A0	SI (D7)	Write-only	SCL (D6)	1
P/S	Data/ command	Data	Read/write	Serial clock														
HIGH	A0	D0 to D7	$\overline{\text{RD}}$ , $\overline{\text{WR}}$															
LOW	A0	SI (D7)	Write-only	SCL (D6)														

Pin name	I/O	Description	Number of pins																																													
CLS	I	<p>Pin that selects the validity/invalidity of the built-in oscillator circuit for display clocks.</p> <p>CLS=HIGH: Built-in oscillator circuit valid  CLS=LOW: Built-in oscillator circuit invalid (external input)  When CLS=LOW, display clocks are input from the CL pin.  When the S1D15705 series is used for the master/slave configuration, each of the CLS pins is set to the same level together.</p> <table border="1"> <thead> <tr> <th>Display clock</th> <th>Master</th> <th>Slave</th> </tr> </thead> <tbody> <tr> <td>Built-in oscillator circuit used</td> <td>HIGH</td> <td>HIGH</td> </tr> <tr> <td>External input</td> <td>LOW</td> <td>LOW</td> </tr> </tbody> </table>	Display clock	Master	Slave	Built-in oscillator circuit used	HIGH	HIGH	External input	LOW	LOW	1																																				
Display clock	Master	Slave																																														
Built-in oscillator circuit used	HIGH	HIGH																																														
External input	LOW	LOW																																														
M/S	I	<p>Pin that selects the master/slave operation for the S1D15705 series. The liquid crystal display system is synchronized by outputting the timing signal required for the liquid crystal display for the master operation and inputting the timing signal required for the liquid crystal display for the slave operation.</p> <p>M/S=HIGH : Master operation  M/S=LOW : Slave operation  According to the M/S and CLS states, the following table is given.</p> <table border="1"> <thead> <tr> <th>M/S</th> <th>CLS</th> <th>Oscillator circuit</th> <th>Power supply circuit</th> <th>CL</th> <th>FR</th> <th>SYNC</th> <th>FRS</th> <th>DOF</th> </tr> </thead> <tbody> <tr> <td>HIGH</td> <td>HIGH</td> <td>Valid</td> <td>Valid</td> <td>Output</td> <td>Output</td> <td>Output</td> <td>Output</td> <td>Output</td> </tr> <tr> <td></td> <td>LOW</td> <td>Invalid</td> <td>Valid</td> <td>Input</td> <td>Output</td> <td>Output</td> <td>Output</td> <td>Output</td> </tr> <tr> <td>LOW</td> <td>HIGH</td> <td>Invalid</td> <td>Invalid</td> <td>Input</td> <td>Input</td> <td>Input</td> <td>Output</td> <td>Input</td> </tr> <tr> <td></td> <td>LOW</td> <td>Invalid</td> <td>Invalid</td> <td>Input</td> <td>Input</td> <td>Input</td> <td>Output</td> <td>Input</td> </tr> </tbody> </table>	M/S	CLS	Oscillator circuit	Power supply circuit	CL	FR	SYNC	FRS	DOF	HIGH	HIGH	Valid	Valid	Output	Output	Output	Output	Output		LOW	Invalid	Valid	Input	Output	Output	Output	Output	LOW	HIGH	Invalid	Invalid	Input	Input	Input	Output	Input		LOW	Invalid	Invalid	Input	Input	Input	Output	Input	1
M/S	CLS	Oscillator circuit	Power supply circuit	CL	FR	SYNC	FRS	DOF																																								
HIGH	HIGH	Valid	Valid	Output	Output	Output	Output	Output																																								
	LOW	Invalid	Valid	Input	Output	Output	Output	Output																																								
LOW	HIGH	Invalid	Invalid	Input	Input	Input	Output	Input																																								
	LOW	Invalid	Invalid	Input	Input	Input	Output	Input																																								
CL	I/O	<p>Display clock I/O pin  According to the M/S and CLS states, the following table is given.</p> <table border="1"> <thead> <tr> <th>M/S</th> <th>CLS</th> <th>CL</th> </tr> </thead> <tbody> <tr> <td>HIGH</td> <td>HIGH</td> <td>Output</td> </tr> <tr> <td></td> <td>LOW</td> <td>Input</td> </tr> <tr> <td>LOW</td> <td>HIGH</td> <td>Input</td> </tr> <tr> <td></td> <td>LOW</td> <td>Input</td> </tr> </tbody> </table> <p>When the S1D15705 series is used for the master/slave configuration, each CL pin is connected.</p>	M/S	CLS	CL	HIGH	HIGH	Output		LOW	Input	LOW	HIGH	Input		LOW	Input	1																														
M/S	CLS	CL																																														
HIGH	HIGH	Output																																														
	LOW	Input																																														
LOW	HIGH	Input																																														
	LOW	Input																																														
FR	I/O	<p>Liquid crystal alternating current signal I/O pin  M/S=HIGH : Output  M/S=LOW : Input  When the S1D15705 series is used for the master/slave configuration, each FR pin is connected.</p>	1																																													
SYNC	I/O	<p>Liquid crystal synchronizing current signal I/O pin  M/S=HIGH : Output  M/S=LOW : Input  When the S1D15705 series is used for the master/slave configuration, each SYNC pin is connected.</p>	2																																													
DOF	I/O	<p>Liquid crystal display blanking control pin  M/S=HIGH : Output  M/S=LOW : Input  When the S1D15705 series is used for the master/slave configuration, each DOF pin is connected.</p>	1																																													
IRS	I	<p>V<sub>5</sub> voltage adjusting resistor selection pin  IRS=HIGH: Built-in resistor used  IRS=LOW: Built-in resistor not used. The V<sub>5</sub> voltage is adjusted by the VR pin and stand-alone split resistor.  Valid only at master operation. The pin is fixed to HIGH or LOW at slave operation.</p>	1																																													
HPM	I	<p>Power supply control pin of the power supply circuit for liquid crystal drive  HPM=HIGH : Normal mode  HPM=LOW : High power supply mode  Valid only at master operation. The pin is fixed to HIGH or LOW at slave operation.</p>	1																																													

## Liquid Crystal Drive Pin

Pin name	I/O	Description	Number of pins																																			
SEG0 to SEGn	O	<p>Output pins for the LCD segment drive. For the pin assignment by model, refer to the table below.</p> <table border="1"> <thead> <tr> <th>Product name</th> <th>SEG</th> <th>Number of pins</th> </tr> </thead> <tbody> <tr> <td>S1D15705*****</td> <td>SEG0 to SEG167</td> <td>168</td> </tr> <tr> <td>S1D15707*****/S1D15708*****</td> <td>SEG0 to SEG199</td> <td>200</td> </tr> </tbody> </table> <p>Contents of the display RAM and FR signal are combined to select a desired level among VDD, V2, V3 and V5.</p> <table border="1"> <thead> <tr> <th rowspan="2">RAM data</th> <th rowspan="2">FR</th> <th colspan="2">Output voltage</th> </tr> <tr> <th>Display normal operation</th> <th>Display reversal</th> </tr> </thead> <tbody> <tr> <td>HIGH</td> <td>HIGH</td> <td>VDD</td> <td>V2</td> </tr> <tr> <td>HIGH</td> <td>LOW</td> <td>V5</td> <td>V3</td> </tr> <tr> <td>LOW</td> <td>HIGH</td> <td>V2</td> <td>VDD</td> </tr> <tr> <td>LOW</td> <td>LOW</td> <td>V3</td> <td>V5</td> </tr> <tr> <td>Power save</td> <td>—</td> <td colspan="2">VDD</td> </tr> </tbody> </table>	Product name	SEG	Number of pins	S1D15705*****	SEG0 to SEG167	168	S1D15707*****/S1D15708*****	SEG0 to SEG199	200	RAM data	FR	Output voltage		Display normal operation	Display reversal	HIGH	HIGH	VDD	V2	HIGH	LOW	V5	V3	LOW	HIGH	V2	VDD	LOW	LOW	V3	V5	Power save	—	VDD		168 or 200
Product name	SEG	Number of pins																																				
S1D15705*****	SEG0 to SEG167	168																																				
S1D15707*****/S1D15708*****	SEG0 to SEG199	200																																				
RAM data	FR	Output voltage																																				
		Display normal operation	Display reversal																																			
HIGH	HIGH	VDD	V2																																			
HIGH	LOW	V5	V3																																			
LOW	HIGH	V2	VDD																																			
LOW	LOW	V3	V5																																			
Power save	—	VDD																																				
COM0 to COMn		<p>Output pins for the LCD common drive. For the pin assignment by model, refer to the table below.</p> <table border="1"> <thead> <tr> <th>Product name</th> <th>SEG</th> <th>Number of pins</th> </tr> </thead> <tbody> <tr> <td>S1D15705*****</td> <td>COM0 to COM63</td> <td>64</td> </tr> <tr> <td>S1D15707*****</td> <td>COM0 to COM31</td> <td>32</td> </tr> <tr> <td>S1D15708*****</td> <td>COM0 to COM15</td> <td>16</td> </tr> </tbody> </table> <p>Scan data and FR signal are combined to select a desired level among VDD, V1, V4 and V5.</p> <table border="1"> <thead> <tr> <th>Scanning data</th> <th>FR</th> <th>Output voltage</th> </tr> </thead> <tbody> <tr> <td>HIGH</td> <td>HIGH</td> <td>V5</td> </tr> <tr> <td>HIGH</td> <td>LOW</td> <td>VDD</td> </tr> <tr> <td>LOW</td> <td>HIGH</td> <td>V1</td> </tr> <tr> <td>LOW</td> <td>LOW</td> <td>V4</td> </tr> <tr> <td>Power save</td> <td>—</td> <td>VDD</td> </tr> </tbody> </table>	Product name	SEG	Number of pins	S1D15705*****	COM0 to COM63	64	S1D15707*****	COM0 to COM31	32	S1D15708*****	COM0 to COM15	16	Scanning data	FR	Output voltage	HIGH	HIGH	V5	HIGH	LOW	VDD	LOW	HIGH	V1	LOW	LOW	V4	Power save	—	VDD	64 or 32 or 16					
Product name	SEG	Number of pins																																				
S1D15705*****	COM0 to COM63	64																																				
S1D15707*****	COM0 to COM31	32																																				
S1D15708*****	COM0 to COM15	16																																				
Scanning data	FR	Output voltage																																				
HIGH	HIGH	V5																																				
HIGH	LOW	VDD																																				
LOW	HIGH	V1																																				
LOW	LOW	V4																																				
Power save	—	VDD																																				
COMS	O	Indicator dedicated COM output pin. Set to OPEN when not used. When COMS is used for the master/slave configuration, the same signal is output to both the master and slave.	2																																			

## Test Pin

Pin name	I/O	Description	Number of pins
TEST1 to 6	I/O	IC chip test pin. Fix the pin to HIGH. When using the temperature sensor with the S1D15705*10**, refer to "Section 17. Temperature Sensor Circuit".	6
TEST7 to 9	I/O	IC chip test pin. Take into consideration so that the capacity of lines cannot be exhausted by setting the pin to OPEN.	3

## 6. FUNCTION DESCRIPTION

### MPU Interface

#### Selection of interface type

The S1D15705 series transfers data through 8-bit bidirectional data buses (D7 to D0) or serial data input (SI). By setting the polarity of the P/S pin to either HIGH or LOW, the 8-bit parallel data entry or serial data entry can be selected as listed in Table 1.

Table 1

P/S	$\overline{\text{CS1}}$	CS2	A0	$\overline{\text{RD}}$	$\overline{\text{WR}}$	C86	D7	D6	D5 to D0
HIGH: Parallel data entry	$\overline{\text{CS1}}$	CS2	A0	$\overline{\text{RD}}$	$\overline{\text{WR}}$	C86	D7	D6	D5 to D0
LOW: Serial data entry	$\overline{\text{CS1}}$	CS2	A0	—	—	—	SI	SCL	(HZ)

Fix — to HIGH or LOW. HZ indicates the high impedance state.

#### Parallel interface

When the parallel interface is selected (P/S=HIGH), the S1D15705 series can directly be connected to the MPU bus of either the 80 or 68 series MPU by setting the C86 pin to HIGH or LOW as listed in Table 2.

Table 2

C86	$\overline{\text{CS1}}$	CS2	A0	$\overline{\text{RD}}$	$\overline{\text{WR}}$	D7 to D0
H: 68 series MPU bus	$\overline{\text{CS1}}$	CS2	A0	E	R/ $\overline{\text{W}}$	D7 to D0
L: 80 series MPU bus	$\overline{\text{CS1}}$	CS2	A0	$\overline{\text{RD}}$	$\overline{\text{WR}}$	D7 to D0

In addition, the data bus signal can be identified according to the combinations of the A0,  $\overline{\text{RD}}$  (E),  $\overline{\text{WR}}$  (R/ $\overline{\text{W}}$ ) signals as listed in Table 3.

Table 3

Common	68 series	80 series		Function
A0	R/ $\overline{\text{W}}$	$\overline{\text{RD}}$	$\overline{\text{WR}}$	
1	1	0	1	Display data read
1	0	1	0	Display data write
0	1	0	1	Status read
0	0	1	0	Control data write (command)

### Serial interface

When the serial interface is selected (P/S=LOW), the serial data entry (SI) and serial clock input(SCL) can be accepted with the chip in the non-active state ( $\overline{CS1}$ =LOW or CS2=HIGH). The serial interface consists of an 8-bit shift register and a 3-bit counter. Serial data is fetched from the serial data entry pin in the order of D7, D6, ....., and D0 on the leading edge of the serial clock and

converted into 8-bit parallel data on the leading edge of the 8th serial clock, then processed.

Whether to identify that the serial data entry is display data or command is judged by the A0 input, and A0=HIGH indicates display data and A0=LOW indicates the command. After the chip is set to the non-active state, the A0 input is read and identified at the timing on the 8×n-th leading edge of the serial clock. Fig. 1 shows the signal chart of the serial interface.

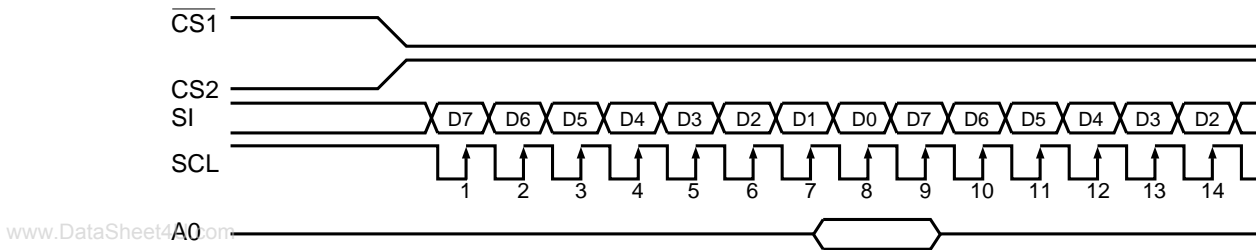

Fig. 1

- When the chip is in the non-active state, both the shift register and counter are reset to the initial state.
- Cannot be read for the serial interface.
- For the SCL signal, pay careful attention to the terminating reflection of lines and external noise. The operation confirmation using actual equipment is recommended.

### Chip select

The S1D15705 series has two chip select pins  $\overline{CS1}$  and CS2 and enables the MPU interface or serial interface only when  $\overline{CS1}$ =LOW and CS2=HIGH.

When Chip Select is in the non-active state, D0 to D7 are in the high impedance state and the A0, RD, and WR inputs become invalid. When the serial interface is selected, the shift register and counter are reset.

### Display data RAM and internal register access

Since the S1D15705 series access viewed from the MUP side satisfies the cycle time and does not require the wait time, high-speed data transfer is enabled.

The S1D15705 series performs a kind of inter-LSI pipeline processing through the bus holder attached to the internal data bus when it performs the data transfer with the MPU.

For example, when data is written on the display data RAM, the data is first held in the bus holder and written

on the display data RAM up to the next data write cycle. Further, when the MPU reads the contents of display data RAM, the read data at the first data read cycle (dummy) is held in the bus holder and read on the system bus from the bus holder up to the next data read cycle. The read sequence of the display data RAM is restricted. When the address is set, note that the specified address data is not output to the subsequent read instruction and output at the second data read. Therefore single dummy read is required after the address set and write cycle. Fig. 2 shows this relationship.

### Busy flag

When the busy flag is “1”, it indicates that the S1D15705 series is performing an internal operation, and only the status read instruction can be accepted. The busy flag is output to the D7 pin using the status read command. If the cycle time (tCYC) is ensured, the MPU throughput can be improved greatly since this flag needs not be checked before each command.

• Write

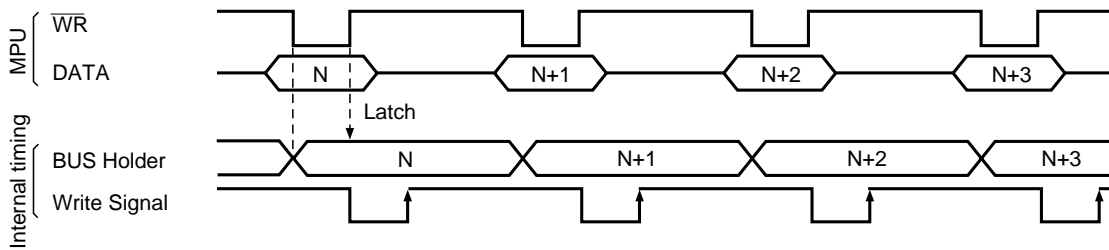

• Read

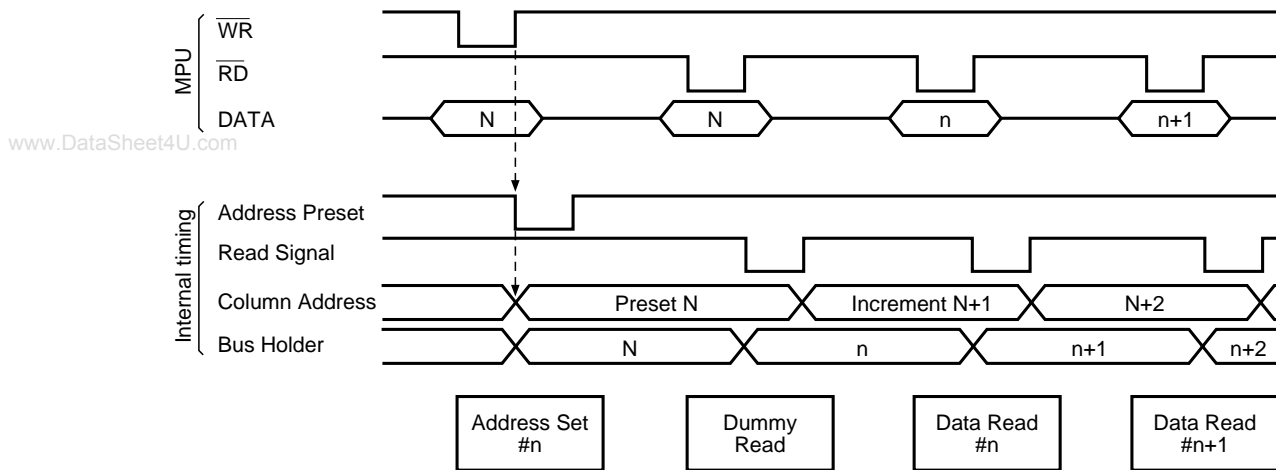

Fig. 2



**Display Data RAM**

**Display data RAM**

This display data RAM stores display dot data and consists of 65 (8 pages × one 8 bit + 1) × 200 bits. Desired bits can be accessed by specifying page and column addresses.

Since the MPU display data D7 to D0 correspond to the common direction of the liquid crystal display, the restrictions at display data transfer is reduced and the

display configuration with the high degree of freedom can easily be obtained when the S1D15705 series is used for the multiple chip configuration.

Besides, the read/write operation to the display data RAM is performed through the I/O buffer from the MPU side independently of the liquid crystal drive signal read. Therefore even when the display data RAM is asynchronously accessed during liquid crystal display, the access will not have any adverse effect on the display such as flickering.

www.DataSheet4U.com

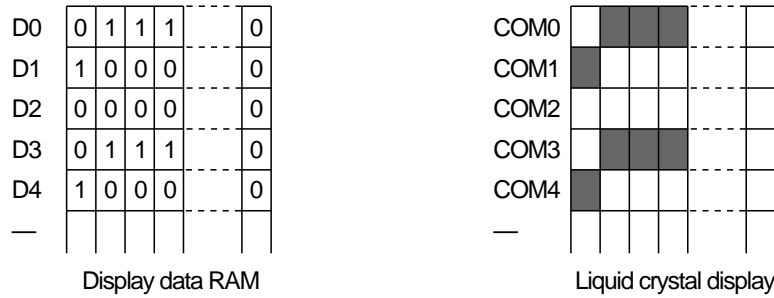

Fig. 3

**Page address circuit**

As shown in Fig. 4, the page address of the display data RAM is specified using the page address set command. To access the data using a new page, the page address is respecified.

The page address 8 (D3,D2,D1,D0=1,0,0,0) is an indicator dedicated RAM area and only the display data D0 is valid.

**Column address circuit**

As shown in Fig. 4, an address on the column side of the display data RAM is specified using the column address set command. Since the specified address is incremented

by 1 whenever the display data read/write command is input, the MPU can successively access the display data.

Besides, the column address stops the increment at the column C7H. Since the column and page addresses are independent each other, for example, the page and column addresses need to be respecified respectively to move from the column C7H of page 0 and column 00H. Further, as shown in Fig. 4, the correspondence relationship between the column address of the display data RAM and the segment address can be reversed using the ADC command (segment driver direction select command). Therefore the IC assignment restrictions at LCD module assembly are reduced.

Table 4

	S1D15705*****		S1D15707***** / S1D15708*****	
SEG output	SEG0	SEG167	SEG0	SEG199
ADC "0"	0 (H)→ Column Address→ A7 (H)		0 (H)→ Column Address→ C7 (H)	
(D0) "1"	C7 (H)← Column Address← 20 (H)		C7 (H)← Column Address← 0 (H)	

**Line address circuit**

When displaying contents of the display data RAM, the line address circuit is used for specifying the corresponding addresses. See Figure 4-1 and 4-2. Using the display start line address set command, the top line is normally selected (when the common output state is normal, COM0 is output. And, when reversed, the S1D15705\*\*\*\*\* outputs COM63, S1D15707\*\*\*\*\* outputs COM31 and

S1D15708\*\*\*\*\* outputs COM15). For the S1D15705\*\*\*\*\*, the display area of 65 lines is secured starting from the specified display start line address in the address incrementing direction. And, 33 lines are provided for the S1D15707\*\*\*\*\* , 17 lines are provided for the S1D15708\*\*\*\*\*.

Dynamically changing the line address using the display start line address set command enables screen scrolling and page change.

S1D15705\*\*\*\*\*: When setting the display start line to one channel

Page Address				Data	Line Address	COM Output
D3	D2	D1	D0			
0	0	0	0	D0	00H	COM0
				D1	01H	COM1
				D2	02H	COM2
				D3	03H	COM3
				D4	04H	COM4
				D5	05H	COM5
				D6	06H	COM6
				D7	07H	COM7
0	0	0	1	D0	08H	COM8
				D1	09H	COM9
				D2	0AH	COM10
				D3	0BH	COM11
				D4	0CH	COM12
				D5	0DH	COM13
				D6	0EH	COM14
				D7	0FH	COM15
0	0	1	0	D0	10H	COM16
				D1	11H	COM17
				D2	12H	COM18
				D3	13H	COM19
				D4	14H	COM20
				D5	15H	COM21
				D6	16H	COM22
				D7	17H	COM23
0	0	1	1	D0	18H	COM24
				D1	19H	COM25
				D2	1AH	COM26
				D3	1BH	COM27
				D4	1CH	COM28
				D5	1DH	COM29
				D6	1EH	COM30
				D7	1FH	COM31
0	1	0	0	D0	20H	COM32
				D1	21H	COM33
				D2	22H	COM34
				D3	23H	COM35
				D4	24H	COM36
				D5	25H	COM37
				D6	26H	COM38
				D7	27H	COM39
0	1	0	1	D0	28H	COM40
				D1	29H	COM41
				D2	2AH	COM42
				D3	2BH	COM43
				D4	2CH	COM44
				D5	2DH	COM45
				D6	2EH	COM46
				D7	2FH	COM47
0	1	1	0	D0	30H	COM48
				D1	31H	COM49
				D2	32H	COM50
				D3	33H	COM51
				D4	34H	COM52
				D5	35H	COM53
				D6	36H	COM54
				D7	37H	COM55
0	1	1	1	D0	38H	COM56
				D1	39H	COM57
				D2	3AH	COM58
				D3	3BH	COM59
				D4	3CH	COM60
				D5	3DH	COM61
				D6	3EH	COM62
				D7	3FH	COM63
1	0	0	0	D0		COMS

SEG0	SEG1	SEG2	SEG3	SEG4	SEG5	SEG6	SEG7	SEG160	SEG161	SEG162	SEG163	SEG164	SEG165	SEG166	SEG167	LCD Out
C7	C6	C5	C4	C3	C2	C1	C0	A0	A1	A2	A3	A4	A5	A6	A7	0
C7	C6	C5	C4	C3	C2	C1	C0	27	26	25	24	23	22	21	20	1

Column Address
D0
D0
ADC

Common output state: Normal rotation

63 lines

Start

The 65th line is accessed independently of the display start line address.

Fig. 4-1

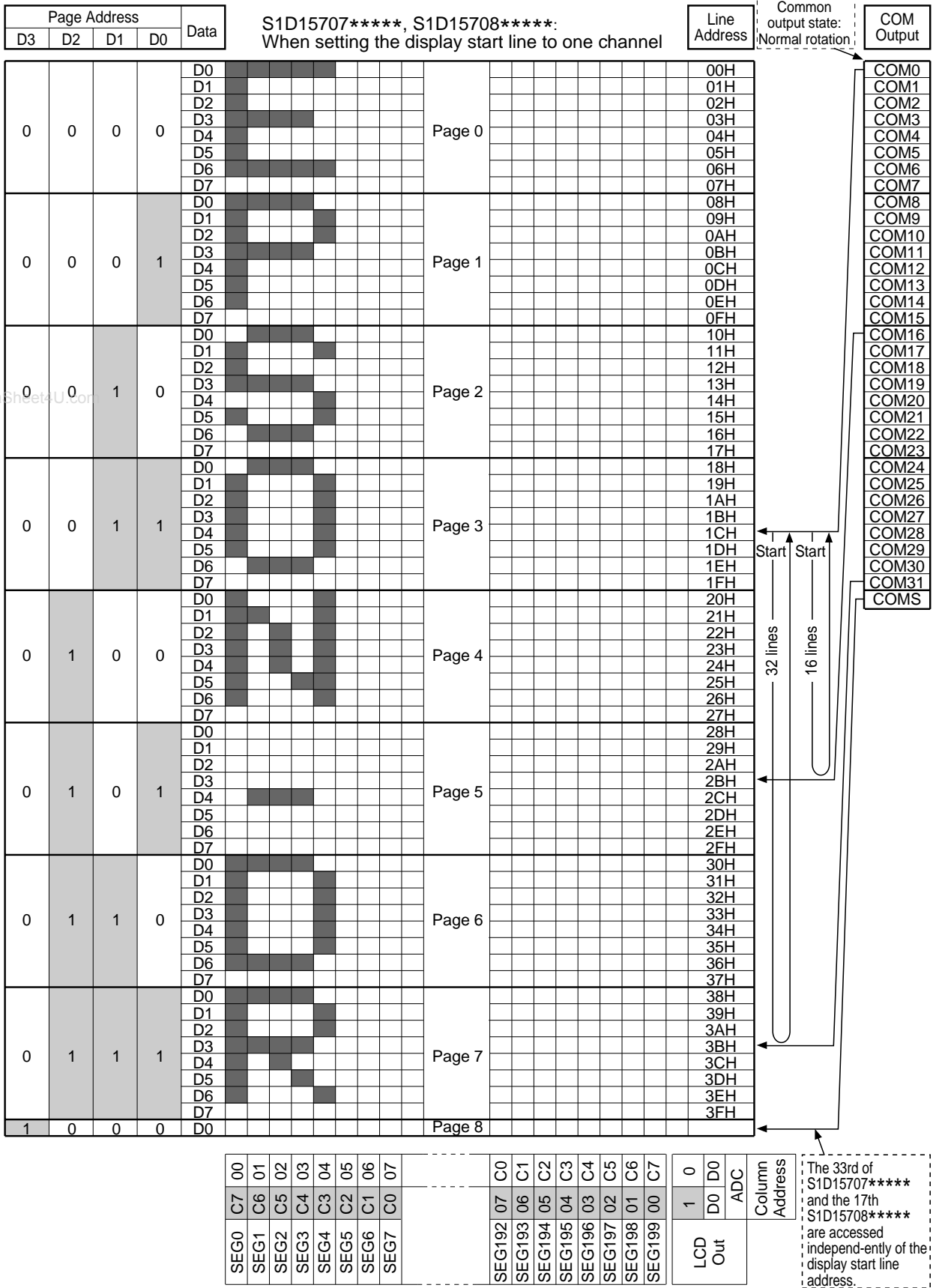

Fig. 4-2

**Display data latch circuit**

The display data latch circuit is a latch that temporarily stores the display data output from the display data RAM to the liquid crystal drive circuit.

Since the Display Normal Rotation/Reversal, Display ON/OFF, and Display All Lighting ON/OFF commands control the data in this latch, the data within the display data RAM is not changed.

**Oscillator Circuit**

This oscillator circuit is a CR type oscillator and generates display clocks. The oscillator circuit is valid only when M/S=HIGH and CLS=HIGH and starts oscillation after the Built-in Oscillator Circuit ON command is entered. When CLS=LOW, the oscillation is stopped and the display clocks are entered from the CL pin.

**Display Timing Generator Circuit**

This display timing generator circuit generates timing signals from the display clocks to the line address circuit and the display latch circuit. It latches the display data to the display data latch circuit and outputs it to the segment drive output pin by synchronizing to the display clocks. The read operation of display data to the liquid crystal drive circuit is completely independent of the access to the display data RAM from the MPU. Therefore

even when the display data RAM is asynchronously accessed during liquid crystal display, the access will not have any adverse effect on the display such as flickering.

The circuit also generates the internal common timing, liquid crystal alternating current signal (FR), and synchronous signal (SYNC) from the display clocks.

As shown in Fig. 5 and 6, the FR normally generates the drive waveforms in the 2-frame alternating current drive system to the liquid crystal drive circuit. It can generate n-line reversal alternating current drive waveforms by setting data (n-1) to the n-line reversal drive register. If a display quality problem such as crosstalk occurs, it can be improved by using the n-line reversal alternating current drive waveforms. Determine the number of lines (n) to which alternating current is applied by actually displaying the liquid crystal.

SNYC is a signal that synchronizes the line counter and common timing generator circuit to the SYNC signal output side IC. Therefore the SYNC signal becomes a waveform at a duty ratio of 50% that synchronizes to the frame synchronization.

When the S1D15705 series is used for the multiple chip configuration, the slave side needs to supply the display timing signals (FR, SYNC, CL, and  $\overline{DOF}$ ) from the master side.

Table 5 shows the state of FR, SYNC, CL, or  $\overline{DOF}$ .

Table 5

Operation mode	FR	SYNC	CL	DOF
Master (M/S=HIGH) Built-in oscillator circuit valid (CLS=HIGH)	Output	Output	Output	Output
Built-in oscillator circuit invalid (CLS=LOW)	Output	Output	Input	Output
Slave (M/S=LOW) Built-in oscillator circuit valid (CLS=HIGH)	Input	Input	Input	Input
Built-in oscillator circuit invalid (CLS=LOW)	Input	Input	Input	Input

**2-frame alternating current drive waveforms**

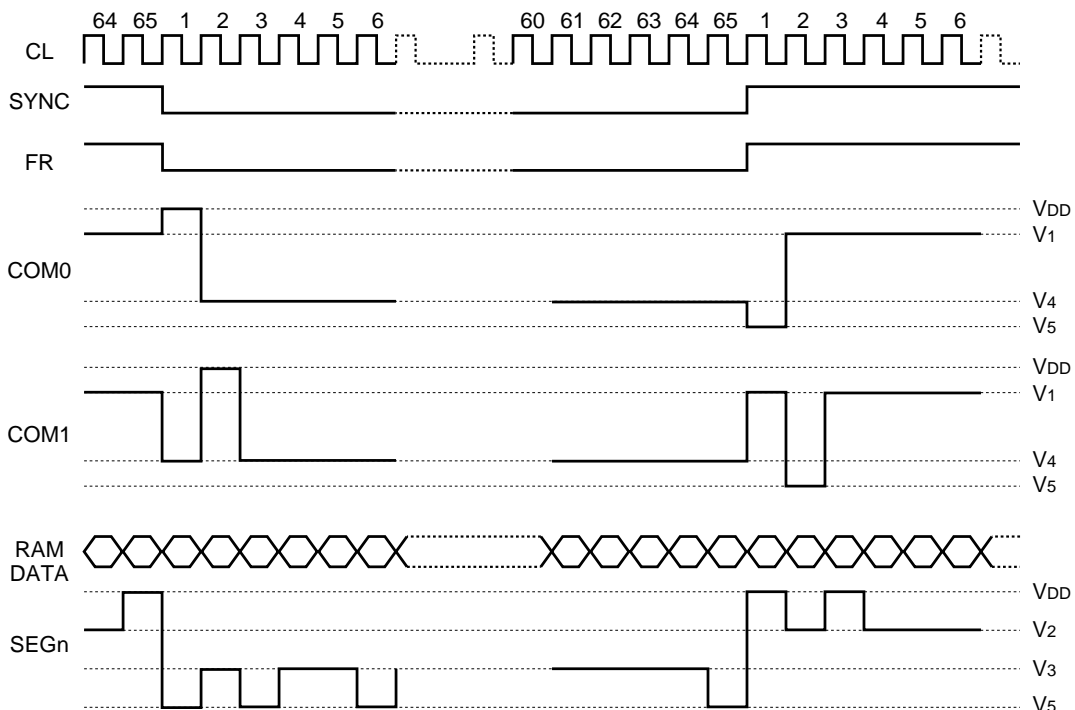

Fig. 5

**n-line reversal alternating current drive waveforms (Example of n=5: when the line reversal register is set to 4)**

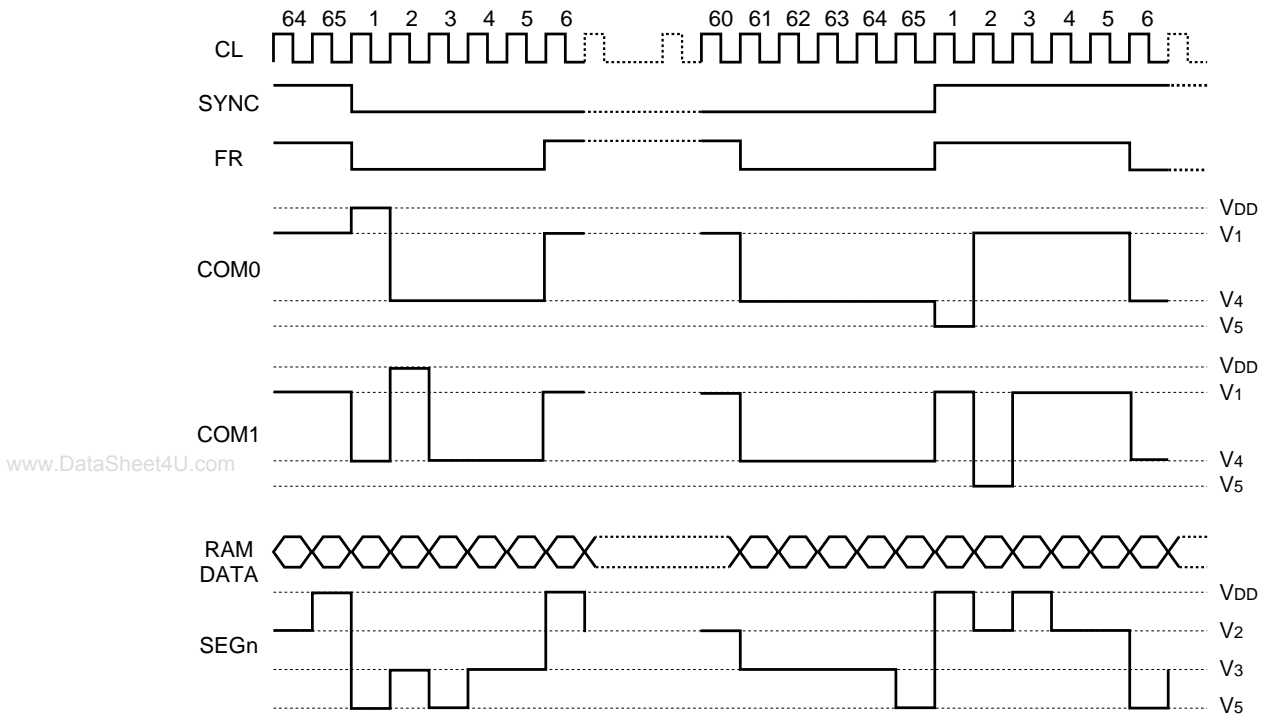

Fig. 6

**Common Output State Selection Circuit**

The S1D15705 series can set the scanning direction of the COM output using the common output state selection command (see Fig. 6). Therefore the IC assignment restrictions at LCD module assembly are reduced.

Table 6

State	COM scanning direction		
	S1D15705*****	S1D15707*****	S1D15708*****
Normal rotation	COM 0 → COM 63	COM 0 → COM 31	COM 0 → COM 15
Reversal	COM 63 → COM 0	COM 31 → COM 0	COM 15 → COM 0

**Liquid Crystal Drive Circuit**

These are a 233-channel (S1D15705\*\*\*\*\* and S1D15707\*\*\*\*\*), a 217-channel (S1D15708\*\*\*\*\*) multiplexers that generate four voltage levels for liquid crystal drive. It outputs the liquid crystal drive voltage that corresponds to the combinations of the display data, COM scanning signal, and FR signal.

Fig. 7 shows examples of the SEG and COM output waveforms.

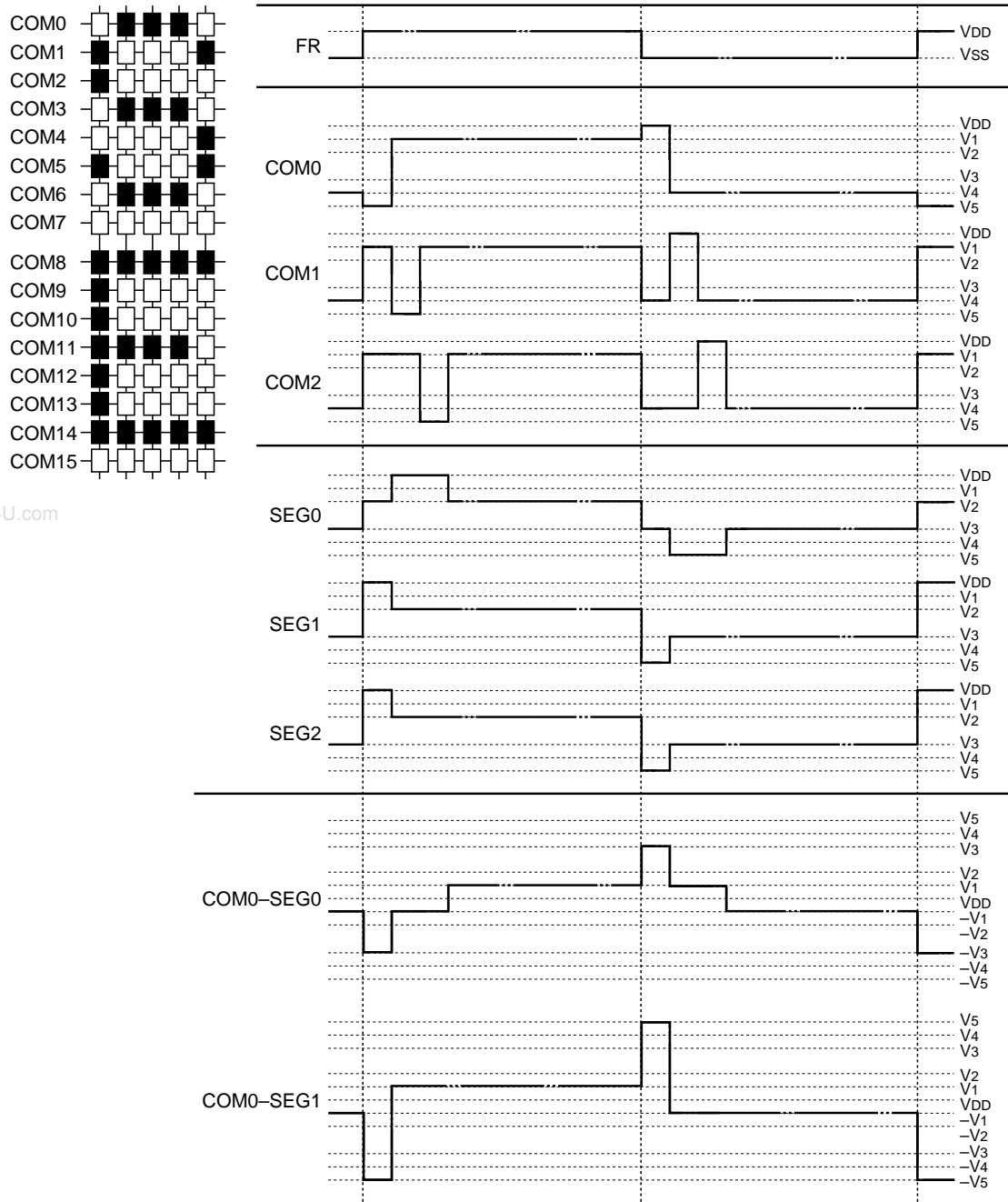

Fig. 7

### Power Supply Circuit

This power supply circuit is a low power supply consumption one that generates the voltage required for the liquid crystal drive and consists of a boosting circuit, voltage adjusting circuit, and voltage follower circuit. It is valid only at master operation.

The power supply circuit ON/OFF controls the boosting

circuit, voltage adjusting circuit, and voltage follower circuit using the power supply control set command, respectively.

Therefore, it can also use the partial functions of the external power supply and built-in power supply together. Table 7 lists the functions that control 3-bit data using the power control set command and Table 8 lists the reference combinations.

Table 7 Description of controlling bits using the power control set command

Item	State	
	"1"	"0"
D2 Boosting circuit control bit	ON	OFF
D1 Voltage adjusting circuit (V adjusting circuit) control bit	ON	OFF
D0 Voltage follower circuit (V/F circuit) control bit	ON	OFF

www.DataSheet4U.com

Table 8 Reference combinations

Status of use	D2	D1	D0	Boosting circuit	V adjusting circuit	V/F circuit	External voltage input	Boosting system pin
① Built-in power supply used	1	1	1	O	O	O	VSS2	Used
② V adjusting circuit and V/F circuit only	0	1	1	X	O	O	VOUT, VSS2	OPEN
③ V/F circuit only	0	0	1	X	X	O	V5, VSS2	OPEN
④ External power supply only	0	0	0	X	X	X	V1 to V5	OPEN

- The boosting system pin indicates the CAP1+, CAP1-, CAP2+, CAP2-, or CAP3- pin.
- Although the combinations other than those listed in the above table are also possible, they cannot be recommended because they are not actual use methods.

### Boosting circuit

The boosting circuit incorporated in the S1D15705 series enables the quadruple boosting, triple boosting, and double boosting of the VDD – VSS2 potential.

For the quadruple boosting, the VDD ↔ VSS2 potential is quadruple-boosted to the negative side and output to the VOUT pin by connecting the capacitor C1 between CAP1+↔ and CAP1-, between CAP2+↔ and CAP2-, between CAP1+↔ and CAP3-, and between VSS2↔ and VOUT.

For the triple boosting, the VDD ↔ VSS2 potential is

triple-boosted to the negative side and output to the VOUT pin by connecting the capacitor C1 between CAP1+↔ and CAP1-, between CAP2+↔ and CAP2-, and between VSS2↔ and VOUT and strapping both CAP3- and VOUT pins.

For the double boosting, the VDD ↔ VSS2 potential is doubly boosted to the negative side and output to the VOUT pin by connecting the capacitor C1 between CAP1+↔ and CAP1-, and between VSS2↔, setting CAP2+ to OPEN, and VOUT and strapping CAP2-, CAP3-, and VOUT pins.

Fig. 8 shows the relationships of boosting potential.

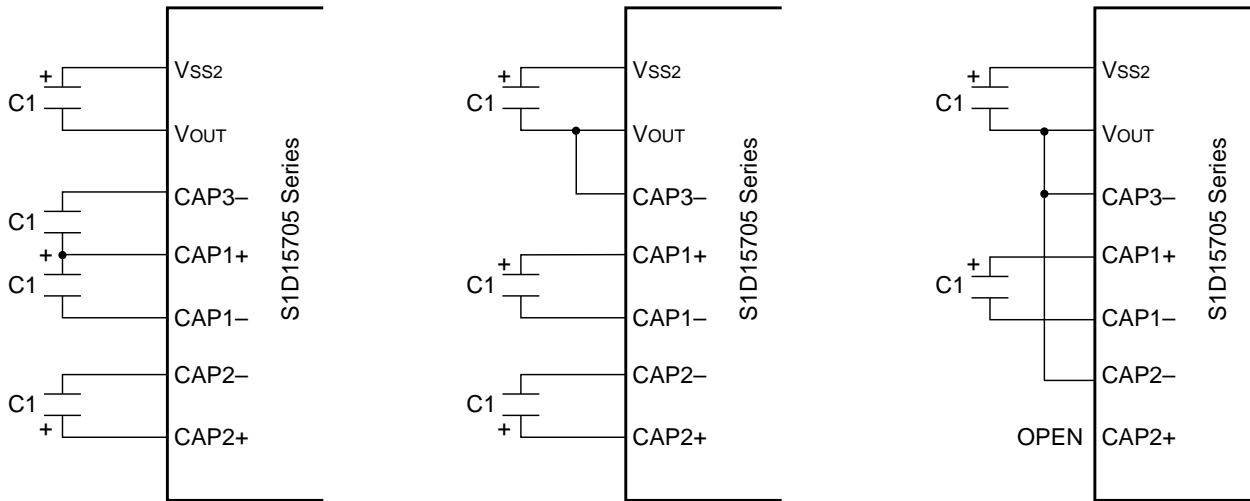

www.DataSheet4U.com Quadruple boosting circuit

Triple boosting circuit

Double boosting circuit

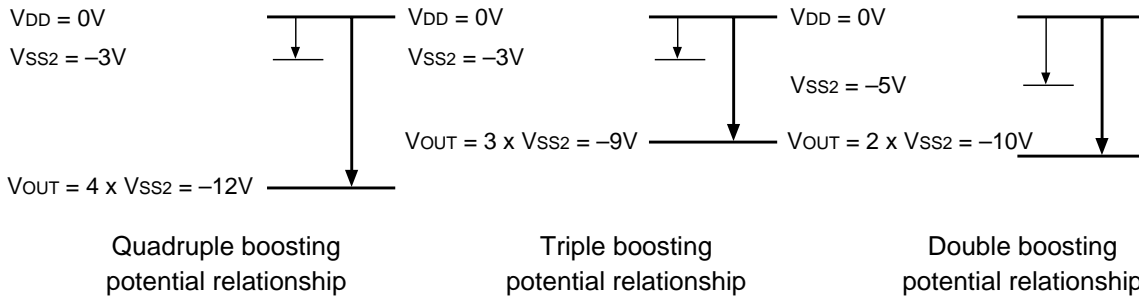

Quadruple boosting potential relationship

Triple boosting potential relationship

Double boosting potential relationship

Fig. 8

- Set the VSS2 voltage range so that the voltage of the VOUT pin cannot exceed the absolute maximum ratings.

**Voltage adjusting circuit**

The boosting voltage generated in VOUT outputs the liquid crystal drive voltage V5 through the voltage adjusting circuit.

Since the S1D15705 series incorporates a high-accuracy constant power supply, 64-step electronic control function, and V5 voltage adjusting resistor, a high-accuracy voltage adjusting circuit can eliminate and save parts.

- (A) When using the V5 voltage adjusting built-in resistor  
The liquid crystal power supply voltage V5 can be controlled only using the command without an external resistor and the light and shade of liquid crystal display be adjusted by using the V5 voltage adjusting built-in resistor and the electronic control function.

The V5 voltage can be obtained according to Expression A-1 within the range of  $|V5| < |VOUT|$ .

$$\begin{aligned}
 V_5 &= \left(1 + \frac{Rb}{Ra}\right) \cdot V_{EV} \\
 &= \left(1 + \frac{Rb}{Ra}\right) \cdot \left(1 - \frac{\alpha}{162}\right) \cdot V_{REG} \quad \text{(Expression A-1)} \\
 \because V_{EV} &= \left(1 - \frac{\alpha}{162}\right) \cdot V_{REG}
 \end{aligned}$$



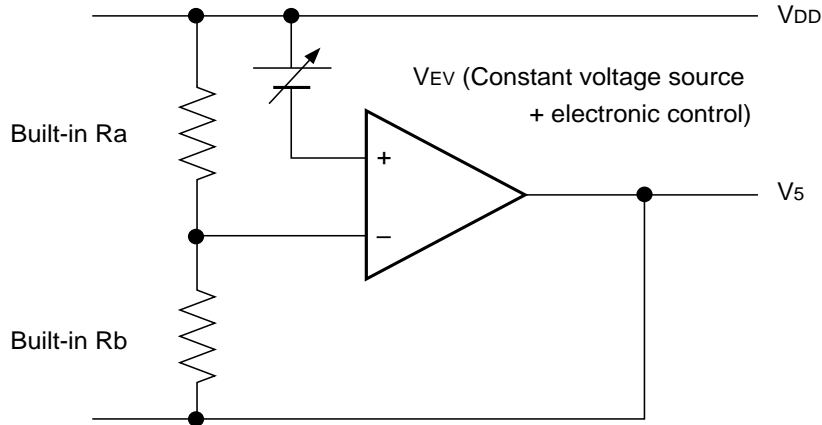

Fig. 9

VREG is a constant voltage source within an IC, and the value at Ta=25°C is constant as listed in Table 9.

www.DataSheet4U.com

Table 9

Device	Temperature gradient	Unit	VREG	Unit
Internal power supply	-0.05	[%/°C]	-2.1	[V]

α indicates an electronic control command value. Setting data in a 6-bit electronic control register enters one state among 64 states. Table 10 lists the values of α based on the setup of the electronic control register.

Table 10

D5	D4	D3	D2	D1	D0	α
0	0	0	0	0	0	63
0	0	0	0	0	1	62
0	0	0	0	1	0	61
		⋮				⋮
1	1	1	1	0	1	2
1	1	1	1	1	0	1
1	1	1	1	1	1	0

Rb/Ra indicates the V5 voltage adjusting built-in resistance ratio and can be adjusted into eight steps using the V5 voltage adjusting built-in resistance ratio set command. The reference values of the (1+Rb/Ra) ratio are obtained as listed in Table 11 by setting 3-bit data in the V5 voltage adjusting built-in resistance ratio register.

Table 11 (Reference values)

Register			S1D15705****	S1D15707****/S1D15708****
			Device per temperature gradient [Unit: %/°C]	Device per temperature gradient [Unit: %/°C]
D2	D1	D0	-0.05	-0.05
0	0	0	4.5	3.0
0	0	1	5.0	3.5
0	1	0	5.5	4.0
0	1	1	6.0	4.5
1	0	0	6.5	5.0
1	0	1	7.0	5.5
1	1	0	7.6	6.0
1	1	1	8.1	6.5

It is necessary to take a manufacturing deviation of upto ±7% of the built-in resistance ratio into consideration. When this is not permissible, supplement external Ra and Rb to adjust the V5 voltage.

Figs. 10 show the V5 voltage reference values per temperature gradient device based on the values of the V5 voltage adjusting built-in resistance ratio register and electronic control register at Ta=25°C.

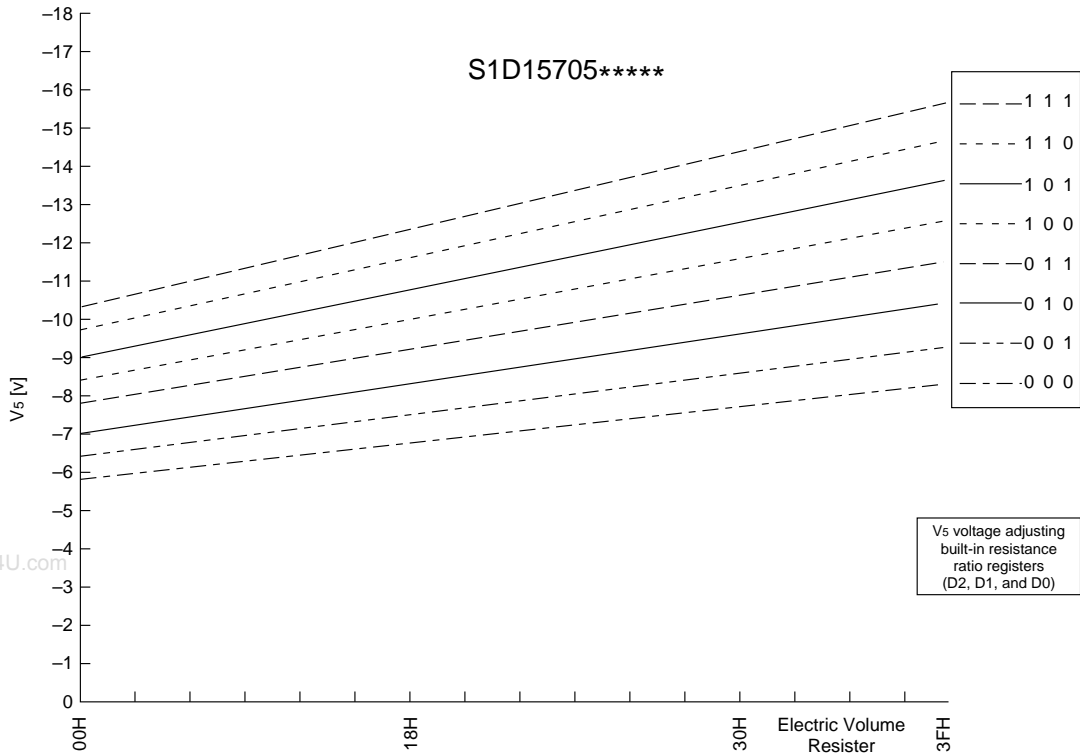

Fig. 10-1 S1D15705\*\*\*\*\* Temperature gradient = -0.05%/°C device

V5 voltage based on the values of V5 voltage adjusting built-in resistance ratio register and electronic control register

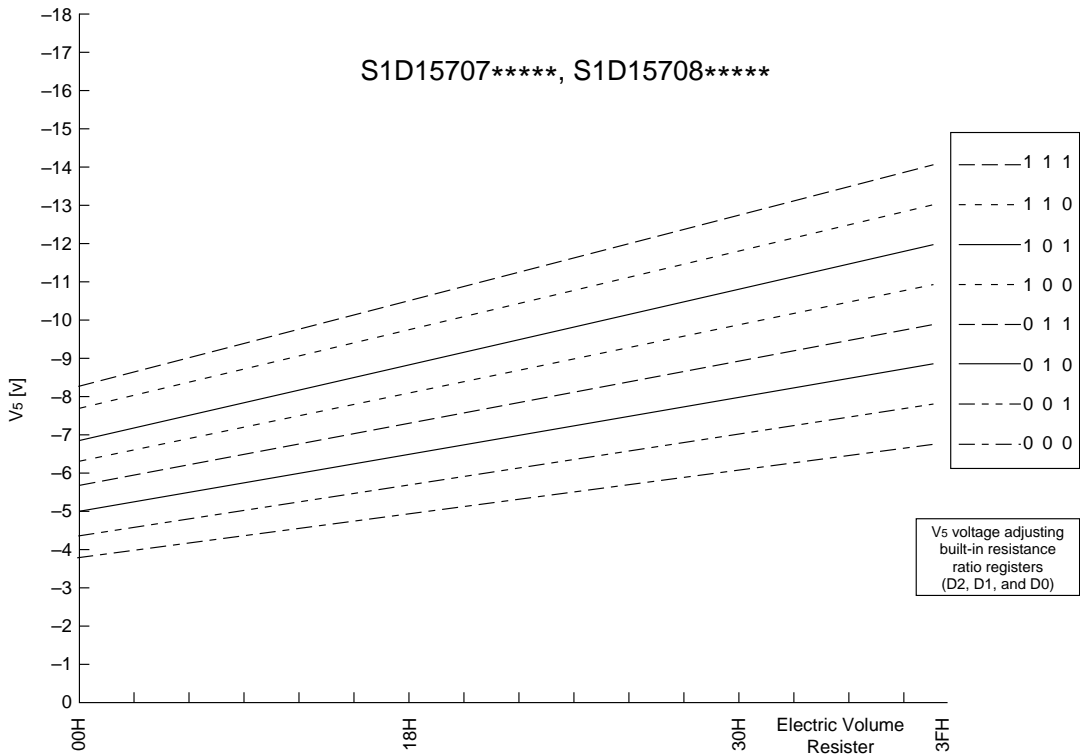

Fig. 10-2 S1D15707\*\*\*\*\*, S1D15708\*\*\*\*\* Temperature gradient = -0.05%/°C device

V5 voltage based on the values of V5 voltage adjusting built-in resistance ratio register and electronic control register

\*S1D15708 should be used in system operating voltage ranges. ( $V_5 - V_{DD} = -10V$  or  $V_5 - V_{DD} = \text{less than } -10V$ )

<Setting example: S1D15705\*\*\*\*\* When setting  $V_5 = -9\text{ V}$  at  $T_a=25^\circ\text{C}$ >  
 From Fig. 8 and Expression A-1.

Table 12

Description	Register					
	D5	D4	D3	D2	D1	D0
$V_5$ voltage adjusting	–	–	–	0	1	0
electronic control	0	1	1	0	0	1

In this case, Table 13 lists the  $V_5$  voltage variable range and pitch width using the electronic control function.

Table 13

$V_5$	Min.		Typ.		Max.	Unit
Variable range	–11.6	to	–9.3	to	–7.1	[V]
Pitch width			67			[mV]

(B) When using the external resistor (not using the  $V_5$  voltage adjusting built-in resistor) ①  
 The liquid crystal power supply voltage  $V_5$  can also be set by adding the resistors ( $R_{a'}$  and  $R_{b'}$ ) between  $V_{DD}$  and  $V_R$  and between  $V_R$  and  $V_5$  without the  $V_5$  voltage adjusting built-in resistor (IRS pin=LOW). Also in this case, the liquid crystal power supply voltage  $V_5$  can be controlled using the command and the light and shade of liquid crystal display can be adjusted by using the electronic control function.

The  $V_5$  voltage can be obtained from Expression B-1 by setting the external resistors  $R_{a'}$  and  $R_{b'}$  within the range of  $|V_5| < |V_{OUT}|$ .

$$V_5 = \left(1 + \frac{R_{b'}}{R_{a'}}\right) \cdot V_{EV} \tag{Expression B-1}$$

$$= \left(1 + \frac{R_{b'}}{R_{a'}}\right) \cdot \left(1 - \frac{\alpha}{162}\right) \cdot V_{REG}$$

$$\left[\because V_{EV} = \left(1 - \frac{\alpha}{162}\right) \cdot V_{REG}\right]$$

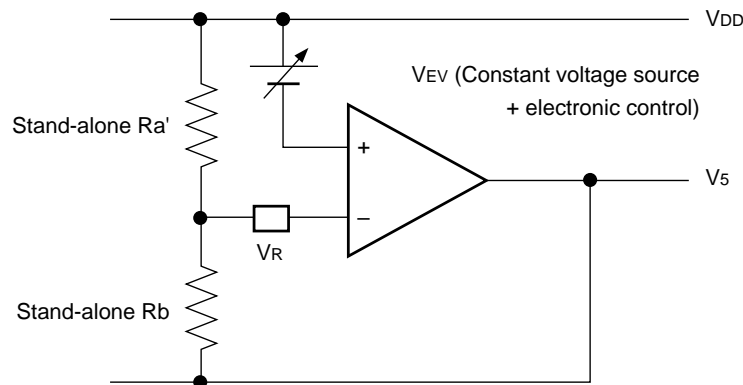

Fig. 11

<Setting example: S1D15705\*\*\*\*\* When setting  $V_5=-7\text{ V}$  at  $T_a=25^\circ\text{C}$ >

Set the value of the electronic control register as the intermediate value ( $D_5, D_4, D_3, D_2, D_1, D_0$ ) = (1,0,0,0,0,0). From the foregoing we can establish the expression:

$$\alpha = 31$$

$$V_{REG} = -2.1\text{V}$$

From Expression B-1, it follows that

$$V_5 = \left(1 + \frac{R_{b'}}{R_{a'}}\right) \cdot \left(1 - \frac{\alpha}{162}\right) \cdot V_{REG} \tag{Expression B-2}$$

$$-7\text{V} = \left(1 + \frac{R_{b'}}{R_{a'}}\right) \cdot \left(1 - \frac{31}{162}\right) \cdot (-2.1)$$

Also, suppose the current applied to  $R_{a'}$  and  $R_{b'}$  is  $5\mu\text{A}$ .

$$R_{a'} + R_{b'} = 1.4\text{M}\Omega \tag{Expression B-2}$$

It follows that

Therefore from Expressions B-2 and B-3, we have

$$\frac{R_{b'}}{R_{a'}} = 3.12$$

$$R_{a'} = 340\text{k}\Omega$$

$$R_{b'} = 1060\text{k}\Omega$$

In this case, Table 14 lists the  $V_5$  voltage variable range and pitch width using the electronic control function.

Table 14

V5	Min.		Typ.		Max.	Unit
Variable range	-8.6	to	-7.0	to	-5.3	[V]
Pitch width			52			[mV]

(C) When using the external resistor (not using the V5 voltage adjusting built-in resistor) ②  
 In the use of the above-mentioned external resistor, the liquid crystal power supply voltage V5 can also be set by adding the resistors to finely adjust Ra' and Rb'. Also in this case, the liquid crystal power supply voltage V5 can be controlled using the command and the light and shade of liquid crystal display can be adjusted by using the electronic control function.

The V5 voltage can be obtained from the following expression C-1 by setting the external resistors R1, R2 (variable resistors), and R3 within the range of  $|V5| < |VOUT|$  and finely adjusting R2 ( $\Delta R2$ ).

$$\begin{aligned}
 V_5 &= \left(1 + \frac{R_3 + R_2 - \Delta R_2}{R_1 + \Delta R_2}\right) \cdot V_{EV} \\
 &= \left(1 + \frac{R_3 + R_2 - \Delta R_2}{R_1 + \Delta R_2}\right) \cdot \left(1 - \frac{\alpha}{162}\right) \cdot V_{REG} \\
 \therefore V_{EV} &= \left(1 - \frac{\alpha}{162}\right) \cdot V_{REG} \quad (\text{Expression C-1})
 \end{aligned}$$

www.DataSheet4U.com

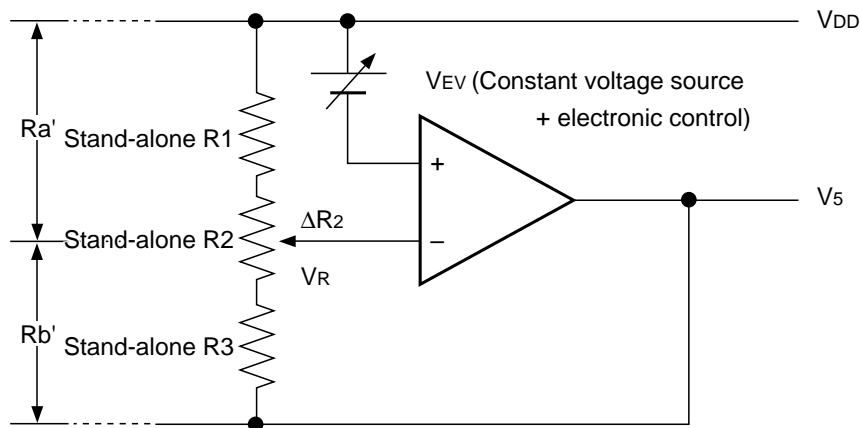

Fig. 12

<Setting example: S1D15705\*\*\*\*\* When setting V5=-5 to -9 V at Ta=25°C>

Set the value of the electronic control register as the intermediate value (D5, D4, D3, D2, D1, D0) = (1,0,0,0,0,0). From the foregoing we can establish the expression:

$$\begin{aligned}
 \alpha &= 31 \\
 V_{REG} &= -2.1V
 \end{aligned}$$

When  $\Delta R2=0\Omega$ , to obtain V5=-9 V from Expression C-1, it follows that

$$-9V = \left(1 + \frac{R_3 + R_2}{R_1}\right) \cdot \left(1 - \frac{31}{162}\right) \cdot (-2.1) \quad (\text{Expression C-2})$$

When  $\Delta R2=R2$ , to obtain V5=-5V, it follows that

$$-5V = \left(1 + \frac{R_3}{R_1 + R_2}\right) \cdot \left(1 - \frac{31}{162}\right) \cdot (-2.1) \quad (\text{Expression C-3})$$

Also, suppose the current applied between VDD and V5 is 5μA.

$$R_1 + R_2 + R_3 = 1.4M\Omega \quad (\text{Expression C-4})$$

It follows that

Therefore from Expressions C-2, C-3, and C-4, we have

$$\begin{aligned}
 R_1 &= 264k\Omega \\
 R_2 &= 211k\Omega \\
 R_3 &= 925k\Omega
 \end{aligned}$$

In this case, Table 6-15 lists the V5 voltage variable range and pitch width using the electronic control function.

Table 15

V5	Min.		Typ.		Max.	Unit
Variable range	-8.7	to	-7.0	to	-5.3	[V]
Pitch width			53			[mV]

- When using the V5 voltage adjusting built-in resistor or electronic control function, the state where at least the voltage adjusting circuit and voltage follower circuit are operated together needs to be set using the power control set command. Also when the boosting circuit is OFF, the voltage needs to be applied from VOUT.
- The VR pin is valid only when the V5 voltage adjusting built-in resistor (IRS pin=LOW). Set the VR pin to OPEN when using the V5 voltage adjusting built-in resistor (IRS pin=HIGH).
- Since the VR pin has high input impedance, noise must be taken into consideration such as for short and shielded lines.

**Liquid crystal voltage generator circuit**

The V5 voltage is resistor-split within an IC and generates the V1, V2, V3, and V4 potentials required for the liquid crystal drive.

Further, the V1, V2, V3, and V4 potentials are impedance-converted by the voltage follower and supplied to the liquid crystal drive circuit.

Using the bias set command allows you to select a desired bias ratio from 1/9 or 1/7 for the S1D15705\*\*\*\*\* and 1/6 or 1/5 for the S1D15707\*\*\*\*\* and S1D15708\*\*\*\*\*.

**High power mode**

The power supply circuit incorporated in the S1D15705 series has the ultra-low power consumption (normal mode: HPM=HIGH). Therefore the display quality

may be deteriorated in large load liquid crystal or panels. In this case, the display quality can be improved by setting HPM pin=LOW (high power mode). Whether to use the power supply circuit in this mode should need the display confirmation by actual equipment. Besides, if the improvement is insufficient even for the high power mode setting, the crystal liquid drive power needs to be supplied externally.

**Command sequence when the built-in power supply is turned off**

To turn off the built-in power supply, set it in the power save state and then turn off the power supply according to the command sequence shown in Fig. 13 (procedure).

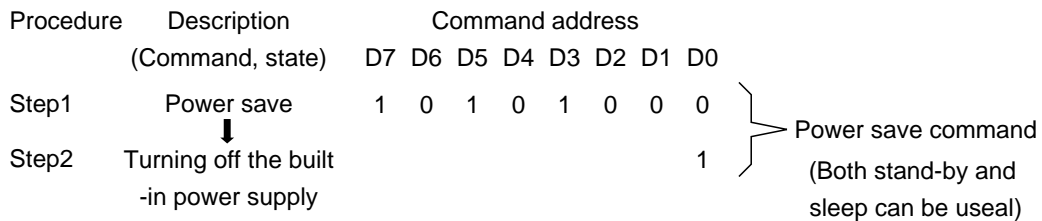

Fig. 13

Reference circuit examples

① Built-in power supply used

(1) When using the V5 voltage adjusting built-in resistor  
(Example of  $V_{SS2}=V_{SS}$ , quadruple boosting)

(2) When not using the V5 voltage adjusting built-in resistor  
(Example of  $V_{SS2}=V_{SS}$ , quadruple boosting)

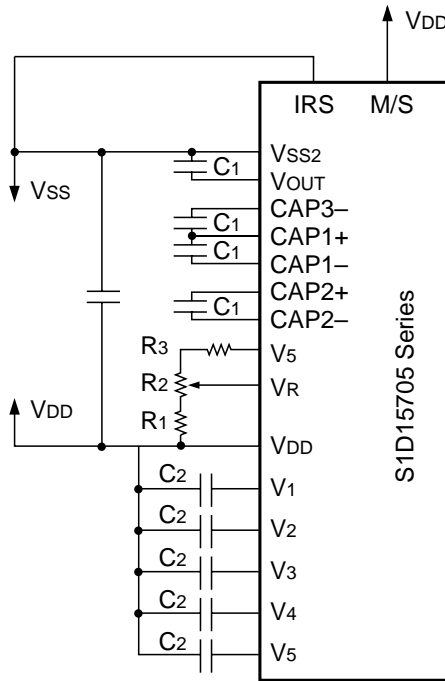
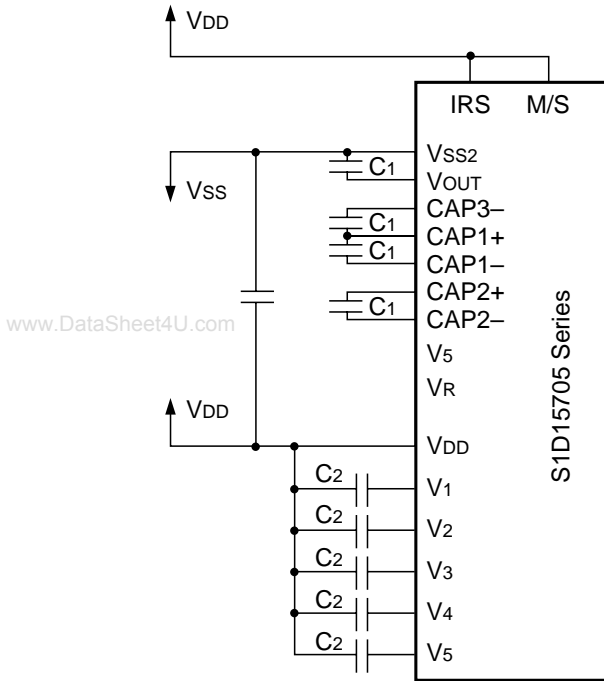

② Only the voltage adjusting circuit and V/F circuit used

(1) When using the V5 voltage adjusting built-in resistor

(2) When not using the V5 voltage adjusting built-in resistor

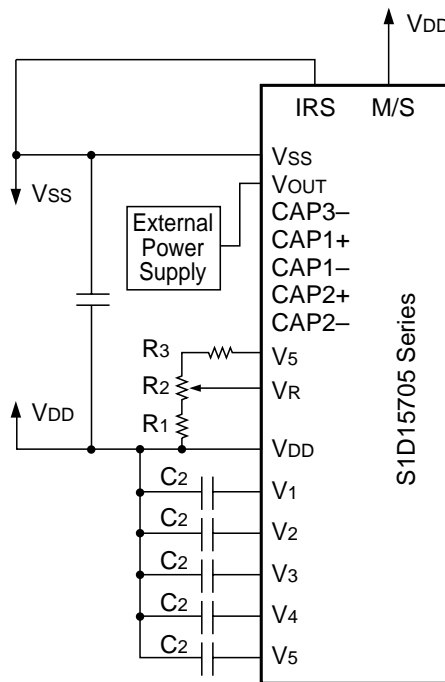
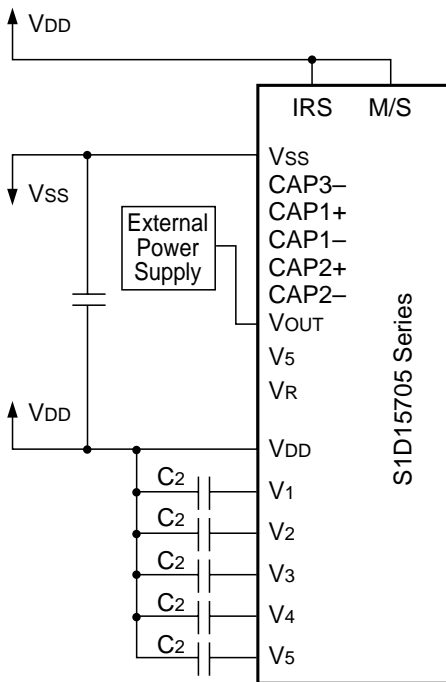

③ Only the V/F circuit used

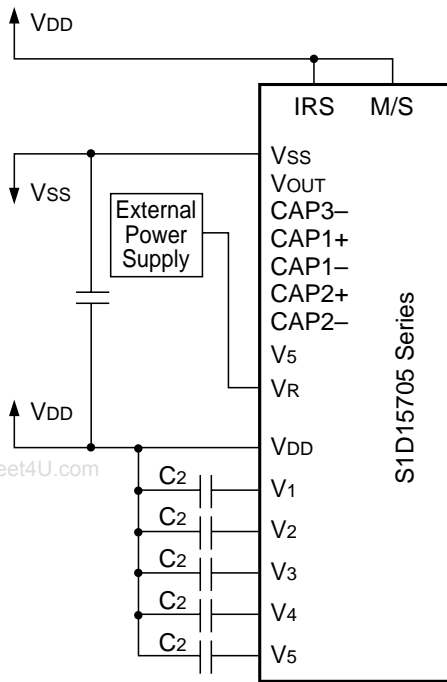

④ Only the external power supply used  
Depending on all external power supplies

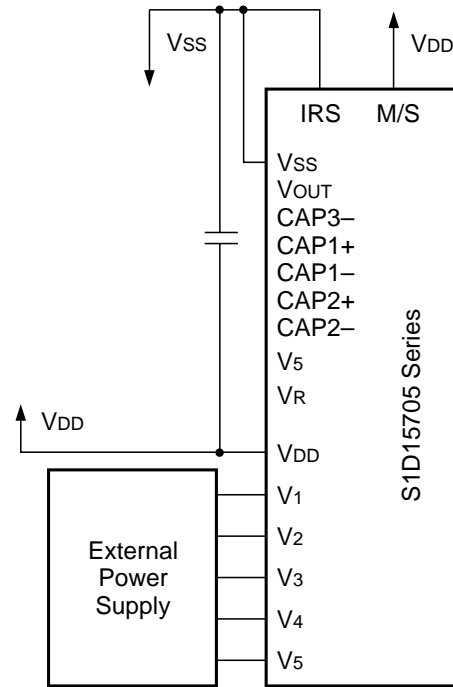

Common reference setting example  
At  $V_5 = -8$  to  $-12$  V variable

Item	Setting value	Unit
C1	1.0 to 4.7	$\mu\text{F}$
C2	0.01 to 1.0	$\mu\text{F}$

Fig. 14

- \*1 Since the VR pin has high input impedance, it uses short and shielded wires.
- \*2 C1 and C2 are determined according to the size of the LCD panel. Set a value so that the liquid crystal drive voltage can be stable.
  - [Setting example] • Turn on the V adjusting circuit and the V/F circuit and apply external voltage.
  - Display LCD heavy load patterns like lateral stripes and determine C2 so that the liquid crystal drive voltages ( $V_1$  to  $V_5$ ) can be stable.
  - Then turn on all built-in power supplies and determine C1.
- \*3 Capacity is connected in order to stabilize voltage between  $V_{DD}$  and  $V_{SS}$  power supplies.

\*4 When the built-in V/F circuit is used to drive an LCD panel with heavy alternating or direct current load, we recommend that external resistance be connected in order to stabilize V/F outputs, or electric potentials, V1, V2, V3 and V4.

Exemplary connection diagram 1 for external resistance

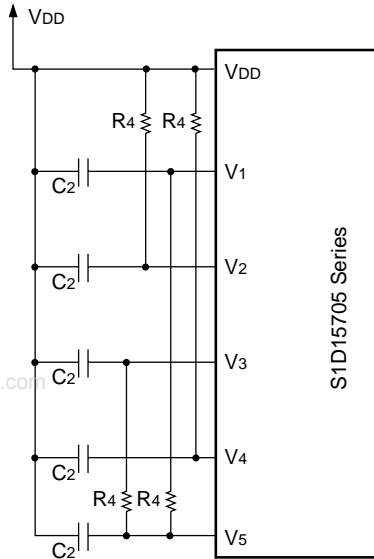

Exemplary connection diagram 2 for external resistance

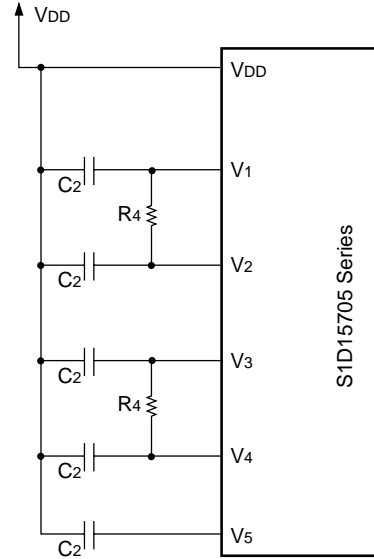

Adjust resistance value R4 to the optimal level by checking driving waveform displayed on the LCD.

Reference setting: R4 = 0.1 to 1.0 [MΩ]

Fig. 15

\*5 Precautions when installing the COG

When installing the COG, it is necessary to duly consider the fact that there exists a resistance of the ITO wiring occurring between the driver chip and the externally connected parts (such as capacitors and resistors). By the influence of this resistance, non-conformity may occur with the indications on the liquid crystal display. Therefore, when installing the COG design the module paying sufficient considerations to the following three points.

1. Suppress the resistance occurring between the driver chip pin to the externally connected parts as much as possible.
2. Suppress the resistance connecting to the power supply pin of the driver chip.
3. Make various COG module samples with different ITO sheet resistance to select the module with the sheet resistance with sufficient operation margin.

Also, as for this driver IC, pay sufficient attention to the following points when connecting to external parts for the characteristics of the circuit.

1. Connection to the boosting capacitors The boosting capacitors (the capacitors connecting to respective CAP pins and capacitor being inserted between VOUT and VSS2) of this IC are being switched over by use of the transistor with very low ON-resistance of about 10Ω. However, when installing the COG,

the resistance of ITO wiring is being inserted in series with the switching transistor, thus dominating the boosting ability.

Consequently, the boosting ability will be hindered as a result and pay sufficient attention to the wiring to respective boosting capacitors.

2. Connection of the smoothing capacitors for the liquid crystal drive

The smoothing capacitors for the liquid crystal driving potentials (V1, V2, V3 and V4) are indispensable for liquid crystal drives not only for the purpose of mere stabilization of the voltage levels. If the ITO wiring resistance which occurs pursuant to installation of the COG is supplemented to these smoothing capacitors, the liquid crystal driving potentials become unstable to cause non-conformity with the indications of the liquid crystal display. Therefore, when using the COG module, we definitely recommend to connect reinforcing resistors externally.

Reference value of the resistance is 100kΩ to 1MΩ. Meanwhile, because of the existence of these reinforcing resistors, current consumption will increase.

Indicated below is an exemplary connection diagram of external resistors. Please make sufficient evaluation work for the display statuses with any connection tests.



Exemplary connection diagram 1.

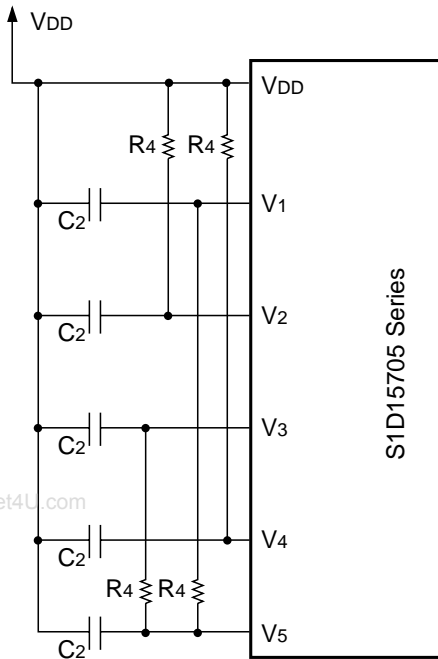

Exemplary connection diagram 2.

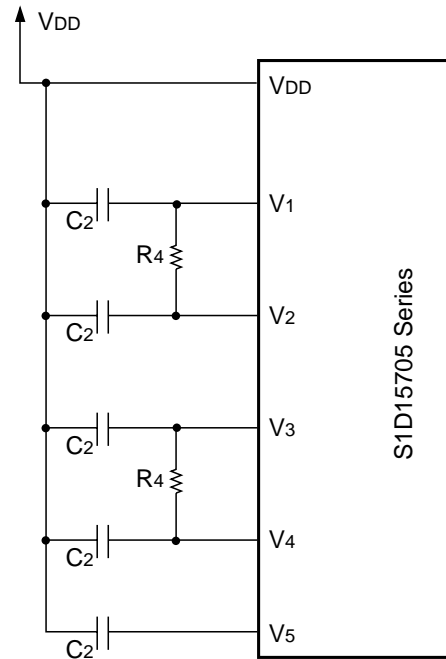

**Reset Circuit**

When the  $\overline{\text{RES}}$  input is set to the LOW level, this LSI enters each of the initial setting states

1. Display OFF
2. Display Normal Rotation
3. ADC Select: Normal rotation (ADC command D0=0)
4. Power Control Register: (D2,D1,D0)=(0,0,0)
5. Register Data Clear within Serial Interface
6. LCD Power Supply Bias Ratio:  
S1D15705: 1/9 bias  
S1D15707/S1D15708: 1/6 bias
7. n-Line Alternating Current Reversal Drive Reset
8. Sleeve mode cancel (standby mode is not canceled)
9. Display All Lighting OFF: (Display All Lighting ON/OFF command D0=LOW)
10. Built-in Oscillator Circuit stopped
11. Static Indicator OFF  
Static Indicator Register: (D1,D2)=(0,0)
12. Read Modify Write OFF
13. Display start line set to the first line
14. Column address set to address 0
15. Page address set to page 0
16. Common Output State Normal rotation
17. V5 Voltage Adjusting Built-in Resistance Ratio Register: (D2,D1,D0)=(0,0,0)
18. Electronic Control Register Set Mode Reset  
Electronic Control Register\* (D5, D4, D3, D2, D1, D0) = (1,0,0,0,0,0)
19. n-Line Alternating Current Reversal Register: (D3, D2, D1, D0) = (0, 0, 0, 0)
20. Test Mode Reset

On the other hand, when using the reset command, only the items 11 to 20 of the above-mentioned initial setting are executed.

When the power is turned on, the initialization using the  $\overline{\text{RES}}$  pin is required. After the initialization using the  $\overline{\text{RES}}$  pin, each input pin needs to be controlled normally. Besides, when the MPU control signal has high impedance, overcurrent may be applied to an IC. After turning on the power, take action so that the input pin cannot have high impedance. The S1D15705 Series discharge electric charges of V5 and VOUT at  $\overline{\text{RES}}$  pin is set to the LOW level. If external power supplies for driving LCD are used, do not input external power while the  $\overline{\text{RES}}$  pin is set to the LOW level to prevent short-circuiting between the external power supplies and VDD.

## 7. COMMAND

The S1D15705 series identifies data bus signals according to the combinations of A0,  $\overline{RD}(E)$ , and  $\overline{WR}(R/\overline{W})$ . Since the interpretation and execution of commands are performed only by the internal timing independently of external clocks, the S1D15705 performs high-speed processing that does not require busy check normally.

The 80 series MPU interface starts commands by inputting low pulses to the  $\overline{RD}$  pin at read and to the  $\overline{WR}$  pin at write operation. The 68 series MPU interface enters the read state when HIGH is input to the R/ $\overline{W}$  pin. It enters the write state when LOW is input to the same pin. It starts commands by inputting high pulses to the E pin (for the timing, see the Timing Characteristics of Chapter 10). Therefore the 68 series MPU interface differs from the 80 series MPU interface in that  $\overline{RD}(E)$  is set to "1 (H)" at status read and display data read in the Command Description and Command Table. The command description is given below by taking the 80 series MPU interface as an example.

When selecting the serial interface, enter sequential data from D7.

### Command description

#### (1) Display ON/OFF

This command specifies display ON/OFF.

A0	E R/ $\overline{W}$		D7	D6	D5	D4	D3	D2	D1	D0	Setting
	$\overline{RD}$	$\overline{WR}$									
0	1	0	1	0	1	0	1	1	1	1	Display ON
										0	Display OFF

For display OFF, the segment and common drivers output the VDD level.

#### (2) Display Start Line Set

This command specifies the display start line address of the display data RAM shown in Fig. 4. The display area is displayed for 65 lines for the S1D15705\*\*\*\*\*, 33 lines for the S1D15707\*\*\*\*\*, and 17 lines for the S1D15708\*\*\*\*\* from the specified line address to the line address increment direction. When this command is used to dynamically change the line address, the vertical smooth scroll and page change are enabled. For details, see the Line address circuit of "Function Description".

A0	E R/ $\overline{W}$		D7	D6	D5	D4	D3	D2	D1	D0	Line address
	$\overline{RD}$	$\overline{WR}$									
0	1	0	0	1	0	0	0	0	0	0	0
					0	0	0	0	0	1	1
					0	0	0	0	1	0	2
							↓				↓
					1	1	1	1	1	0	62
					1	1	1	1	1	1	63

**(3) Page Address Set**

This command specifies the page address that corresponds to the low address when accessing the display data RAM shown in Fig. 4 from the MPU side. The display data RAM can access desired bits when the page address and column address are specified. Even when the page address is changed, the display state will not be changed. For details, see the Page address circuit of “Function Description”.

A0	E R/W		D7	D6	D5	D4	D3	D2	D1	D0	Page address
	RD	WR									
0	1	0	1	0	1	1	0	0	0	0	0
							0	0	0	1	1
							0	0	1	0	2
							↓				↓
							0	1	1	1	7
							1	0	0	0	8

www.DataSheet4U.com

**(4) Column Address Set**

This command specifies the column address of the display data RAM shown in Fig. 4. The column address is set (basically successively) by dividing it into high-order four bits and low-order four bits. Since the column address is automatically incremented by 1 whenever the display data RAM is accessed. The MPU can successively read/write the display data. The column address stops the increment at C7H. In this case, the page address is not changed successively. For details, see the Column address circuit of “Function Description”.

	A0	E R/W		D7	D6	D5	D4	D3	D2	D1	D0
		RD	WR								
High-order bit →	0	1	0	0	0	0	1	A7	A6	A5	A4
Low-order bit →							0	A3	A2	A1	A0

A7	A6	A5	A4	A3	A2	A1	A0	Column address
0	0	0	0	0	0	0	0	0
0	0	0	0	0	0	0	1	1
0	0	0	0	0	0	1	0	2
				↓				↓
1	0	1	0	0	1	1	0	166
1	0	1	0	0	1	1	1	167
				↓				↓
1	1	0	0	0	1	1	0	198
1	1	0	0	0	1	1	1	199

(5) Status Read

A0	E R/W		D7	D6	D5	D4	D3	D2	D1	D0
	RD	WR								
0	0	1	BUSY	ADC	ON/OFF	RESET	0	0	0	0

BUSY	When BUSY=1, indicates an internal operation being done or reset. The command cannot be accepted until BUSY=0 is reached. However, if the cycle time is satisfied, the command needs not be checked.
ADC	Indicates the correspondence relationship between the column address and segment driver. 0: Reversal (column address 199-n ↔ SEG n) 1: Normal rotation (column address n ↔ SEG n) (Reverses the polarity of ADC command.)
ON/OFF	ON/OFF: Specifies display ON/OFF 0: Display ON 1: Display OFF (Reverses the polarity of display ON/OFF command.)
RESET	Indicates the $\overline{RES}$ signal or that initial setting is being done using the reset command. 0: Operating state 1: Resetting

(6) Display Data Write

This command writes 8-bit data to the specified address of the display data RAM. Since the column address is automatically incremented by 1 after the data is written, the MPU can successively write the display data.

A0	E R/W		D7	D6	D5	D4	D3	D2	D1	D0
	RD	WR								
1	1	0	Write data							

(7) Display Data Read

This command reads the 8-bit data in the specified address of the display data RAM. Since the column address is automatically incremented by 1 after the data is written, the MPU can successively read the data consisting of multiple words.

Besides, immediately after the column address is set, dummy read is required one time. For details, see the description of the Display data RAM and internal register access of “Function Description”.

When using the serial interface, the display cannot be read.

A0	E R/W		D7	D6	D5	D4	D3	D2	D1	D0
	RD	WR								
1	0	1	Read data							

**(8) ADC Select (Segment Driver Direction Select)**

This command can reverse the correspondence relationship between the column address of the display RAM data shown in Fig. 4 and the segment driver output. Therefore the order of the segment driver output pin can be reversed using the command. After the display data is written and read, the column address is incremented by 1 according to the column address of Fig. 4. For details, see the Column address circuit of “Function Description”.

A0	$\overline{\text{E}}$	$\overline{\text{R/W}}$	D7	D6	D5	D4	D3	D2	D1	D0	Setting
0	1	0	1	0	1	0	0	0	0	0	Clockwise (normal rotation)
										1	Counterclockwise (reversal)

**(9) Display Normal Rotation/Reversal**

This command can reversal display lighting and non-lighting without overwriting the contents of display data RAM. In this case, the contents of display data RAM are held.

A0	$\overline{\text{E}}$	$\overline{\text{R/W}}$	D7	D6	D5	D4	D3	D2	D1	D0	Setting
0	1	0	1	0	1	0	0	1	1	0	LCD on potential (normal rotation) RAM data HIGH
										1	LCD on potential (reversal) RAM data LOW

**(10) Display All Lighting ON/OFF**

This command can forcedly make all display set in the lighting state irrespective of the contents of display data RAM. In this case, the contents of display data RAM are held. This command has priority over the display normal rotation/reversal command.

A0	$\overline{\text{E}}$	$\overline{\text{R/W}}$	D7	D6	D5	D4	D3	D2	D1	D0	Setting
0	1	0	1	0	1	0	0	1	0	0	Normal display state
										1	Display all lighting

**(11) LCD Bias Set**

This command selects the bias ratio of the voltage required for liquid crystal drive. The command is valid when the V/F circuit of the power supply circuit is operated.

A0	$\overline{\text{E}}$	$\overline{\text{R/W}}$	D7	D6	D5	D4	D3	D2	D1	D0	Selected state	
											S1D15705*****	S1D15707***** / S1D15708*****
0	1	0	1	0	1	0	0	0	1	0	1/9 bias	1/6 bias
										1	1/7 bias	1/5 bias

**(12) Read Modify Write**

This command is used together with the end command. Once this command is entered, the column address can be incremented by 1 only using the display data write command instead of being changed using the display read command. This state is held until the end command is entered. When the end command is entered, the column address returns to the address when the read modify write command is entered. This function can reduce the load of the MPU when repeatedly changing data for a specific display area such as a blinking cursor.

A0	E R/W		D7	D6	D5	D4	D3	D2	D1	D0
	RD	WR								
0	1	0	1	1	1	0	0	0	0	0

\* The commands other than Display Data Read/Write can be used even in Read Modify Write mode. However, the column address set command cannot be used.

- Sequence for cursor display

www.DataSheet4U.com

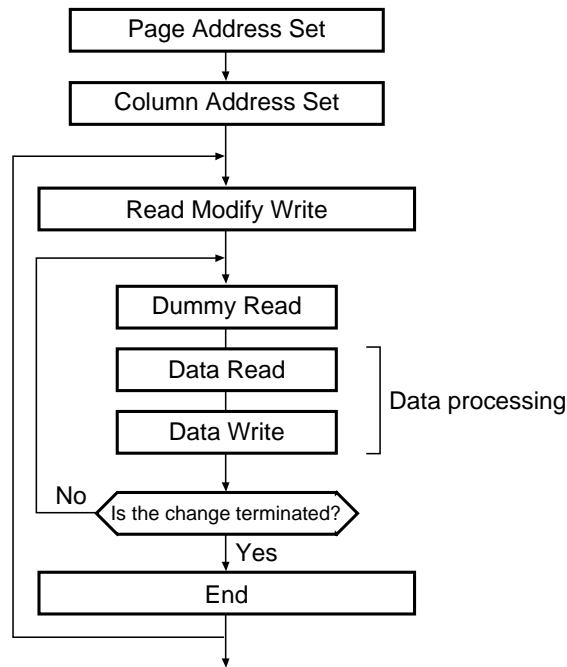

Fig. 16

**(13) End**

This command resets the Read Modify Write mode and returns the column address to the mode initial address.

	<b>E</b>	<b>R/W</b>								
<b>A0</b>	<b>RD</b>	<b>WR</b>	<b>D7</b>	<b>D6</b>	<b>D5</b>	<b>D4</b>	<b>D3</b>	<b>D2</b>	<b>D1</b>	<b>D0</b>
0	1	0	1	1	1	0	1	1	1	0

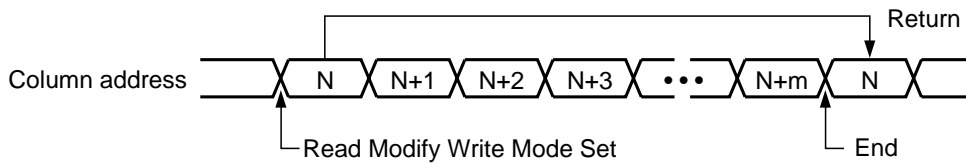

Fig. 17

www.DataSheet4U.com

**(14) Reset**

This command initializes Display Start Line, Column Address, Page Address, Common Output State, V5 Voltage Adjusting Built-in Resistance Ratio, Electronic Control, and Static Indicator and resets the Read Modify Write mode and Test mode. This will not have any effect on the display data RAM. For details, see the Reset of “Function Description”.

Reset operation is performed after the reset command is entered.

	<b>E</b>	<b>R/W</b>								
<b>A0</b>	<b>RD</b>	<b>WR</b>	<b>D7</b>	<b>D6</b>	<b>D5</b>	<b>D4</b>	<b>D3</b>	<b>D2</b>	<b>D1</b>	<b>D0</b>
0	1	0	1	1	1	0	0	0	1	0

The initialization when the power is applied is performed using the reset signal to the  $\overline{\text{RES}}$  pin. The reset command cannot be substituted for the signal.

**(15) Common Output State Selection**

This command can select the scanning direction of the COM output pin. For details, see the Common Output State Selection Circuit of “Function Description”.

<b>E</b>	<b>R/W</b>										<b>Selected state</b>				
		<b>A0</b>	<b>RD</b>	<b>WR</b>	<b>D7</b>	<b>D6</b>	<b>D5</b>	<b>D4</b>	<b>D3</b>	<b>D2</b>	<b>D1</b>	<b>D0</b>	<b>S1D15705*****</b>	<b>S1D15707*****</b>	<b>S1D15708*****</b>
0	1	0	1	1	0	0	0	0	*	*	*	Normal rotation	COM0 → COM63	COM0 → COM31	COM0 → COM15
										1		Reversal	COM63 → COM0	COM31 → COM0	COM15 → COM0

\*: Invalid bit

**(16) Power Control Set**

This command sets the function of the power supply circuit. For details, see the Power Supply Circuit of “Function Description”.

<u>E</u> <u>R/W</u>			D7	D6	D5	D4	D3	D2	D1	D0	Selected state
A0	RD	WR									
0	1	0	0	0	1	0	1	0			Boosting circuit: OFF Boosting circuit: ON
								0			V adjusting circuit: OFF
								1			V adjusting circuit: ON
									0		V/F circuit: OFF
									1		V/F circuit: ON

(V/F circuit: Voltage follower circuit, V adjusting circuit: voltage adjusting circuit)

**(17) V5 Voltage Adjusting Built-in Resistance Ratio Set**

www.DataSheet4U.com

This command sets the V5 voltage adjusting built-in resistance ratio. For details, see the Power Supply Circuit of “Function Description”.

<u>E</u> <u>R/W</u>			D7	D6	D5	D4	D3	D2	D1	D0	Rb to Ra ratio
A0	RD	WR									
0	1	0	0	0	1	0	0	0	0	0	Small
								0	0	1	
								0	1	0	
									↓		↓
								1	1	0	
								1	1	1	Large

**(18) Electronic Control (2-Byte Command)**

This command controls the liquid crystal drive voltage V5 output from the voltage adjusting circuit of the built-in liquid crystal power supply and can adjust the light and shade of liquid crystal display.

Since this command is a 2-byte command that is used together with the electronic control mode set command and electronic control register set command, always use both the commands consecutively.

• Electronic Control Mode Set

Entering this command validates the electronic control register set command. Once the electronic control mode is set, the commands other than the electronic control register set command cannot be used. This state is reset after data is set in the register using the electronic control register set command.

<u>E</u> <u>R/W</u>			D7	D6	D5	D4	D3	D2	D1	D0
A0	RD	WR								
0	1	0	1	0	0	0	0	0	0	1



• Electronic Control Register Set

This command is used to set 6-bit data in the electronic volume register to allow the liquid crystal drive voltage V5 to enter one-state voltage value among 64-state voltage values.

After this command is entered and the electronic control register is set, the electronic control mode is reset.

A0	E R/W		D7	D6	D5	D4	D3	D2	D1	D0	V5
	RD	WR									
0	1	0	*	*	0	0	0	0	0	0	Small
0	1	0	*	*	0	0	0	0	0	1	
0	1	0	*	*	0	0	0	0	1	0	
							↓				↓
0	1	0	*	*	1	1	1	1	1	0	
0	1	0	*	*	1	1	1	1	1	1	Large

\*: Invalid bit

When not using the electronic control function, set (1,0,0,0,0,0).

www.DataSheet4U.com

• Sequence of the electronic control register set

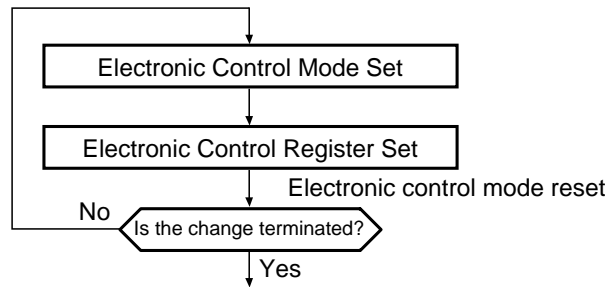

Fig. 18

**(19) Static Indicator (2-Byte Command)**

This command controls the indicator display of the static drive system. The static indicator display is controlled only using this command, and this command is independent of other display control commands.

The static indicator is used to connect the SYNC pin to one of its liquid crystal drive electrodes and the FRS pin to the other. For the electrodes used for the static indicator, the pattern separated from the electrodes for dynamic drive are recommended. When this pattern is too adjacent, the deterioration of liquid crystal and electrodes may be caused.

Since the static indicator ON command is a 2-byte command that is used together with the static indicator register set command, always use both the commands consecutively. (The static indicator OFF command is a 1-byte command.)

• Static Indicator ON/OFF

Entering the static indicator ON command validates the static indicator register set command. Once the static indicator ON command is entered, the commands other than the static indicator register set command cannot be used. This state is reset after the data is set in the register using the static indicator register set command.

A0	E R/W		D7	D6	D5	D4	D3	D2	D1	D0	Static indicator
	RD	WR									
0	1	0	1	0	1	0	1	1	0	0	OFF
										1	ON

• Static Indicator Register Set

This command sets data in the 2-bit static indicator register and sets the blinking state of the static indicator.

A0	E R/W		D7	D6	D5	D4	D3	D2	D1	D0	Indicator display state
	RD	WR									
0	1	0	*	*	*	*	*	*	0	0	OFF
									0	1	ON (blinks at an interval of approximately 0.5 second.)
									1	0	ON (blinks at an interval of approximately one second.)
									1	1	ON (goes on at all times.)

\*: Invalid bit

• Sequence of Static Indicator Register Set

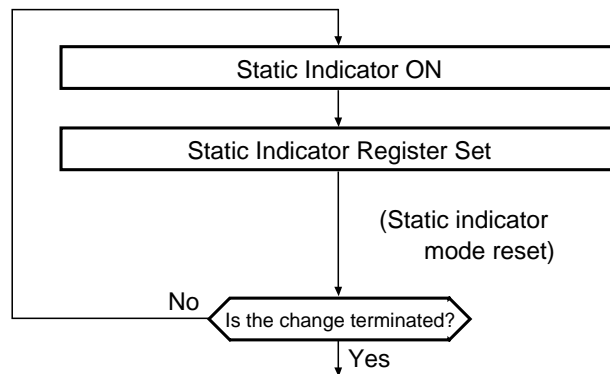

Fig. 19

**(20) Power Save**

This command makes the static indicator enter the power save state and can greatly reduce the power consumption. The power save state consists of the sleep state and stand-by state.

A0	E R/W		D7	D6	D5	D4	D3	D2	D1	D0	Power save state
	RD	WR									
0	1	0	1	0	1	0	1	0	0	0	Stand-by state
										1	Sleep state

The operating state before the display data and power save activation is held in the sleep and stand-by states, and the display data RAM can also be accessed from the MPU.

• Sleep State

This command stops all the operations of LCD display systems, and can reduce the power consumption approximate to the static current when they are not accessed from the MPU. The internal state in the sleep state is as follows:

- (1) The oscillator circuit and the LCD power supply circuit are stopped.
- (2) All liquid crystal drive circuit is stopped and the segment and common drivers output the VDD level.

• Stand-by State

This command stops the operation of the duty LCD display system and operates only the static drive system for indicators. Consequently the minimum current consumption required for the static drive is obtained. The internal state in the stand-by state is as follows:

- (1) The LCD power supply circuit is stopped. The oscillator circuit is operated.
- (2) The duty drive system liquid crystal drive circuit is stopped and the segment and common drivers output the VDD level. The static drive system is operated.

\* When using external power supplies, it is recommended that the function of the external power supply circuit should be stopped at power save activation. For example, when providing each level of the liquid crystal drive voltage using a stand-alone split resistor circuit, it is recommended that the circuit which cuts off the current applied to the split resistor circuit should be added at power save activation. The S1D15705 series has the liquid crystal display blanking control pin  $\overline{DOF}$  and is set to **LOW** at power save activation. The function of the external power supply circuit can be stopped using the  $\overline{DOF}$  output.

**(21) Power Save Reset**

This command resets the power save state and returns the state before power save activation.

A0	E R/W		D7	D6	D5	D4	D3	D2	D1	D0
	RD	WR								
0	1	0	1	1	1	0	0	0	0	1

**(22) n-Line Reversal Drive Register Set**

This command sets the number of reversal lines of the liquid crystal drive in the register. 2 to 16 lines can be set. For details, see the Display Timing Generator Circuit of “Function Description”.

A0	E R/W		D7	D6	D5	D4	D3	D2	D1	D0	Line of reversal lines
	RD	WR									
0	1	0	0	0	1	1	0	0	0	0	—
											2
											3
										↓	↓
							1	1	1	0	15
							1	1	1	1	16

**(23) n-Line Reversal Drive Reset**

This command resets the n-line reversal alternating current drive and returns to the normal 2-frame reversal alternating current drive system. The value of the n-line reversal alternating current drive register is not changed.

$\overline{E}$ $\overline{R/W}$			D7	D6	D5	D4	D3	D2	D1	D0
A0	RD	WR								
0	1	0	1	1	1	0	0	1	0	0

**(24) Built-in Oscillator Circuit ON**

This command starts the operation of the built-in CR oscillator circuit. This command is valid only for the master operation (M/S=HIGH) and built-in oscillator circuit valid (CLS=HIGH).

$\overline{E}$ $\overline{R/W}$			D7	D6	D5	D4	D3	D2	D1	D0
A0	RD	WR								
0	1	0	1	0	1	0	1	0	1	1

www.DataSheet4U.com

**(25) NOP**

Non-Operation

$\overline{E}$ $\overline{R/W}$			D7	D6	D5	D4	D3	D2	D1	D0
A0	RD	WR								
0	1	0	1	1	1	0	0	0	1	1

**(26) Test**

IC chip test command. Do not use this command. If the test command is used incorrectly, it can be reset by setting the RES input to LOW or by using the reset command or NOP.

$\overline{E}$ $\overline{R/W}$			D7	D6	D5	D4	D3	D2	D1	D0
A0	RD	WR								
0	1	0	1	1	1	1	*	*	*	*

\*: Invalid bit

(Note) Although the S1D15705 series holds the command operating state, it may change the internal state if excessive foreign noise is entered. Such action that suppresses the generation of noise and prevents the effect of noise needs to be taken on installation and systems. Besides, to prevent sudden noise, it is recommended that the operating state should periodically be refreshed.

Table 16 S1D15705 Series Commands

Command	Command code										Function	
	A0	RD	WR	D7	D6	D5	D4	D3	D2	D1		D0
(1) Display ON/OFF	0	1	0	1	0	1	0	1	1	1	0	LCD display ON/OFF 0: OFF, 1: ON
(2) Display Start Line Set	0	1	0	0	1	Display start address					1	Sets the display start line address of the display RAM.
(3) Page Address Set	0	1	0	1	0	1	1	Page Address				Sets the page address of the display RAM.
(4) Column Address Set High-Order Bit	0	1	0	0	0	0	1	High order Column address				Sets the high-order four bits of the column address of the display RAM.
Column Address Set Low-Order Bit	0	1	0	0	0	0	0	Low order Column address				Sets the low-order four bits of the column address of the display RAM.
(5) Status Read	0	0	1	Status			0	0	0	0	0	Reads the status information.
(6) Display Data Read	1	1	0	Write data							0	Writes data on the display RAM.
(7) Display Data Write	1	0	1	Read data							0	Reads data from the display RAM.
(8) ADC Select	0	1	0	1	0	1	0	0	0	0	0	Supports the SEG output of the display RAM address. 0: normal rotation, 1: Reversal
(9) Display Normal Rotation/Reversal	0	1	0	1	0	1	0	0	1	1	0	LCD display normal rotation/reversal 0: normal rotation, 1: Reversal
(10) Display All Lighting ON/OFF	0	1	0	1	0	1	0	0	1	0	0	Display all lighting 0: normal display, 1: All ON
(11) LCD Bias Set	0	1	0	1	0	1	0	0	0	1	0	Sets the LCD drive voltage bias ratio. S1D15705***** 0: 1/9, 1: 1/7, S1D15707***** 0: 1/6, 1: 1/5
(12) Read Modify Write	0	1	0	1	1	1	0	0	0	0	0	Increments the column address. At write operation: By 1, at read: 0
(13) End	0	1	0	1	1	1	0	1	1	1	0	Resets Read Modify Write.
(14) Reset	0	1	0	1	1	1	0	0	0	1	0	Internal resetting
(15) Common Output State Selection	0	1	0	1	1	0	0	0	*	*	*	Selects the scanning direction of the COM output. 0: Normal rotation, 1: Reversal
(16) Power Control Set	0	1	0	0	0	1	0	1	Operating state			Selects the state of the built-in power supply
(17) V <sub>5</sub> Voltage Adjusting Internal Resistance Ratio Set	0	1	0	0	0	1	0	0	Resistance ratio setting			Selects the state of the built-in resistance ratio (Rb/Ra).
(18) Electronic Control Mode Set	0	1	0	1	0	0	0	0	0	0	1	Sets the V <sub>5</sub> output voltage in the electronic register.
Electronic Control Register Set	0	1	0	*	*	Electronic control value						
(19) Static Indicator ON/OFF	0	1	0	1	0	1	0	1	1	0	0	0: OFF, 1: ON
Static Indicator Register Set	0	1	0	*	*	*	*	*	*	*	1	State Sets the blinking state.
(20) Power Save	0	1	0	1	0	1	0	1	0	0	0	Moves to the power save state. 0: Stand-by, 1: Sleep
(21) Power Save Reset	0	1	0	1	1	1	0	0	0	0	1	Resets power save.
(22) n-Line Reversal Drive Register Set	0	1	0	0	0	1	1	Number of reversal Line			Sets the number of line reversal drive lines.	
(23) n-Line Reversal Drive Reset	0	1	0	1	1	1	0	0	1	0	0	Resets the line reversal drive.
(24) Built-in Oscillator Circuit ON	0	1	0	1	0	1	0	1	0	1	1	Starts the operation of the built-in CR oscillator circuit.
(25) NOP	0	1	0	1	1	1	0	0	0	1	1	Non-Operation command
(26) Test	0	1	0	1	1	1	1	*	*	*	*	Do not use the IC chip test command.

\*: Invalid bit

## 8. COMMAND SETTING

### Instruction Setup: Reference

#### (1) Initial Setting

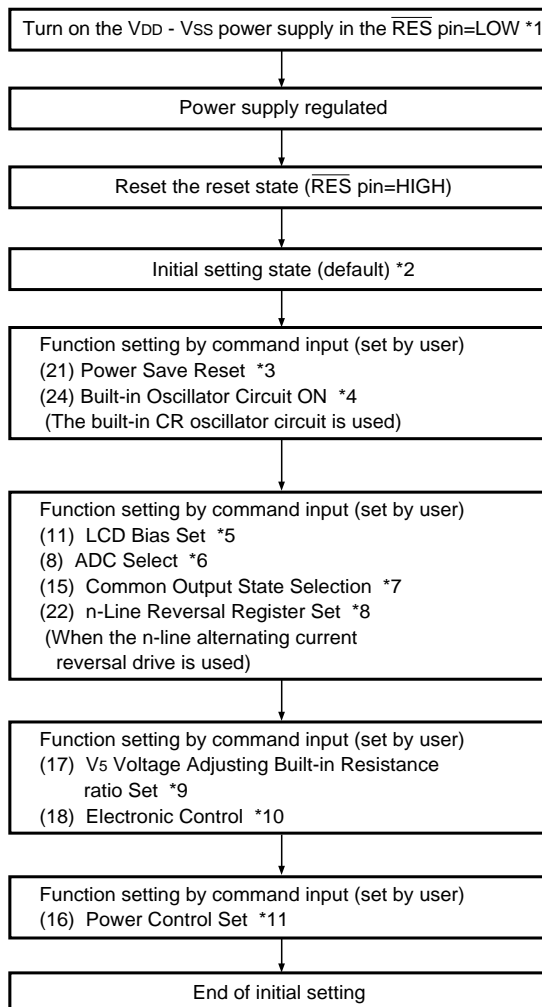

www.DataSheet4U.com

#### Notes: Reference items

- \*1: If external power supplies for driving LCD are used, do not supply voltage on VOUT or V5 pin during the period when  $\overline{\text{RES}} = \text{LOW}$ . Instead, input voltage after releasing the reset state.  
6. Function Description "Reset Circuit"
- \*2: The contents of DDRAM are not defined even in the initial setting state after resetting.  
6. Function Description Section "Reset Circuit"
- \*3: 7. Command Description Item (21) Power save reset
- \*4: 7. Command Description Item (24) Built-in oscillator circuit ON
- \*5: 7. Command Description Item (11) LCD bias set
- \*6: 7. Command Description Item (8) ADC select
- \*7: 7. Command Description Item (15) Common output state selection
- \*8: 6. Function Description Section "Display Timing Generator Circuit", 7. Command Description Item (22) n-Line Reversal Register Set
- \*9: 6. Function Description Section "Power Supply Circuit" and 7. Command Description Item (17) V5 Voltage Adjusting Built-in Resistance ratio Set
- \*10: 6. Function Description Section "Power Supply Circuit" and 7. Command Description Item (18) Electronic Control
- \*11: 6. Function Description Section "Power Supply Circuit" and 7. Command Description Item (16) Power Control Set

**(2) Data Display**

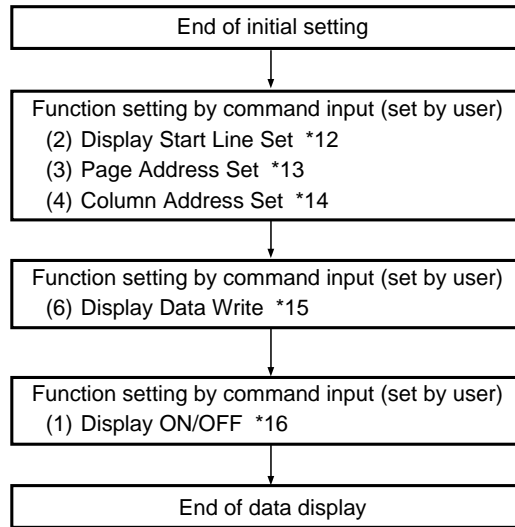

www.DataSheet4U.com

Notes: Reference items

- \*12: 7. Command Description Item (2) Display Start Line Set
- \*13: 7. Command Description Item (3) Page Address Set
- \*14: 7. Command Description Item (4) Column Address Set
- \*15: The contents of DDRAM is not defined after completing initial setting. Enter data in each DDRAM to be used for display.  
7. Command Description Item (6) Display Data Write
- \*16: Avoid activating the display function with entering space characters as the data if possible.  
7. Command Description Item (1) Display ON/OFF

**(3) Refresh \*17**

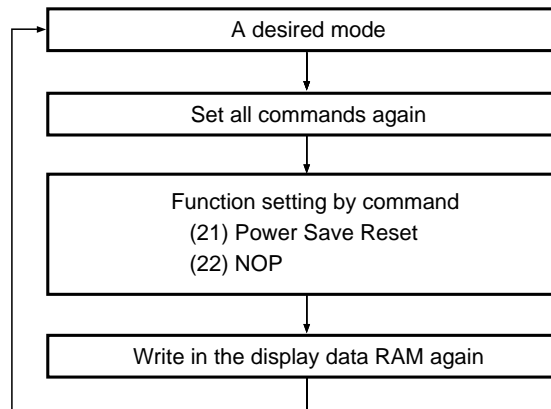

Notes: Reference items

- \*17: It is recommended that the operating modes and display contents be refreshed periodically to prevent the effect of unexpected noise.  
Input (21) Power Save Reset and (22) NOP in order to avoid going into a power save state and IC tip test state accidentally.

(4) Power OFF \*17

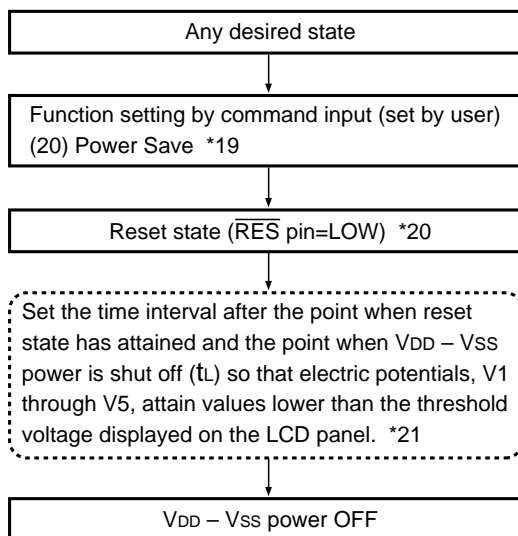

www.DataSheet4U.com

Notes: Reference items

- \*18: This IC is a VDD - VSS power system circuit controlling the LCD driving circuit for the VDD - V5 power system. Shutting of power with voltage remaining in the VDD - V5 power system may cause uncontrolled voltage to be output from the SEG and COM pins. Follow the Power OFF sequence.
- \*19: 7. Command Description Item Power Saving
- \*20: When external power supplies for driving LCD are used, turn all external power supplies off before entering reset state.  
6. Function Description Item Reset Circuit
- \*21: The reference value for the threshold voltage of the LCD panel is 1 [V].  
When the built-in power circuit is used, the discharge time, tH, or the time interval between the point when the reset state has started and the point when voltage between VDD and V5 becomes 1 [V] depends on the VDD - VSS power voltage and the capacity C2 connected between V1 - V5 and VDD.

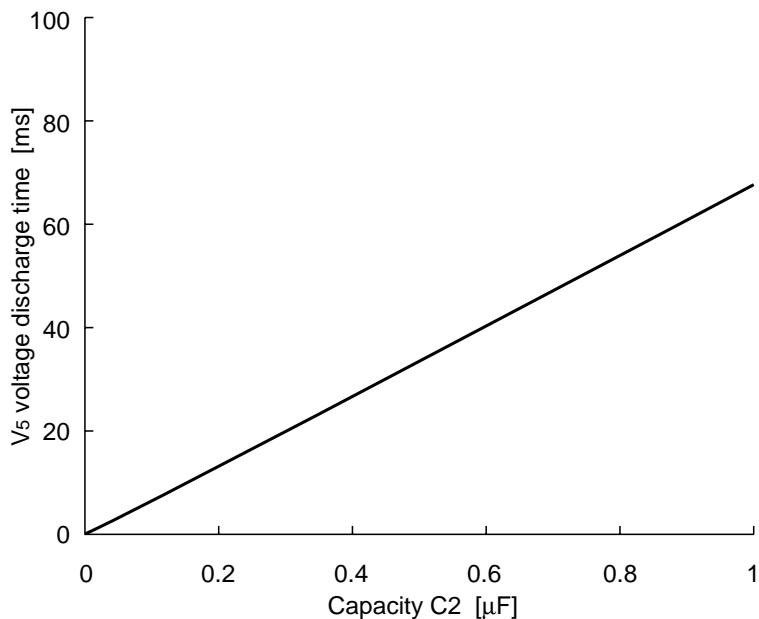

Fig. 20



Set up  $t_L$  so that the relationship,  $t_L > t_H$ , is maintained. A state of  $t_L < t_H$  may cause faulty display.

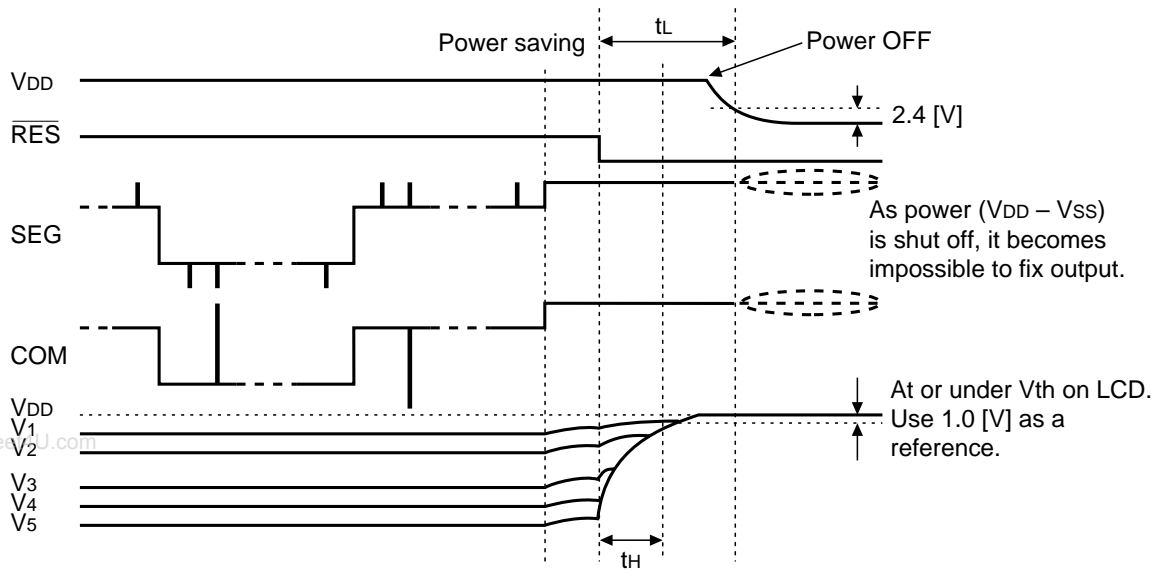
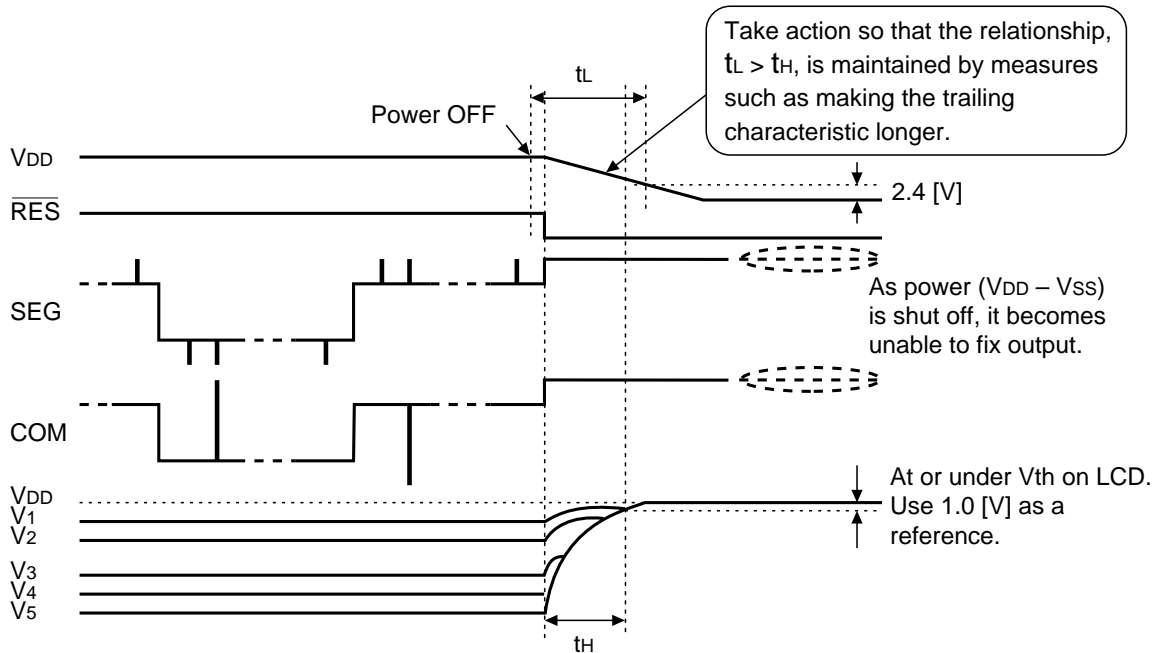

Fig. 21



If command control is disabled when power is OFF, take action so that the relationship,  $t_L > t_H$ , is maintained by measures such as making the trailing characteristic of power ( $V_{DD} - V_{SS}$ ) longer.

Fig. 22

### 9. ABSOLUTE MAXIMUM RATINGS

Table 17

VSS=0 V unless specified otherwise

Item	Symbol	Specification value	Unit
Power supply voltage	VDD	-0.3 to +7.0	V
Power supply voltage (2) (Based on VDD)	VSS2	-7.0 to +0.3	
		At triple boosting -6.0 to +0.3	
At quadruple boosting	-4.5 to +0.3		
Power supply voltage (3) (Based on VDD)	V5, VOUT	-20.0 to +0.3	
Power supply voltage (4) (Based on VDD)	V1, V2, V3, V4	V5 to +0.3	
Input voltage	VIN	-0.3 to VDD+0.3	
Output voltage	VO	-0.3 to VDD+0.3	
Operating temperature	TOPR	-40 to +85	°C
Storage temperature	TCP	-55 to +100	
	Bare chip	-55 to +125	

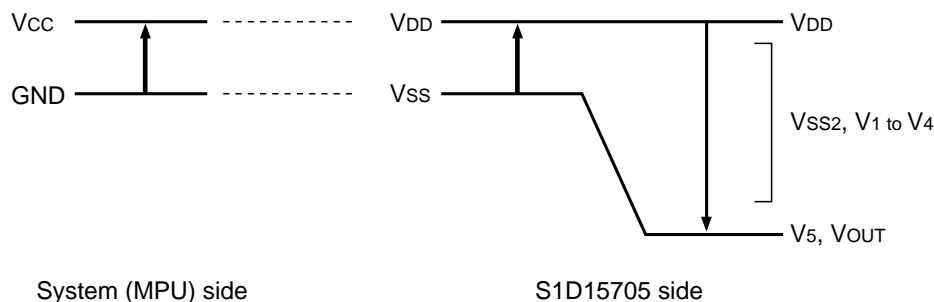

Fig. 23

- (Notes)
1. The values of the VSS2, V1 to V5, and VOUT voltages are based on VDD=0 V.
  2. The V1, V2, V3, and V4 voltages must always satisfy the condition of  $V_{DD} \geq V_1 \geq V_2 \geq V_3 \geq V_4 \geq V_5$ .
  3. The VSS2 and VOUT voltages must always satisfy the condition of  $V_{DD} \geq V_{SS} \geq V_{SS2} \geq V_{OUT}$ .
  4. When LSI is used exceeding the absolute maximum ratings, the LSI may be damaged permanently. Besides, it is desirable that the LSI should be used in the electrical characteristics condition for normal operation. If this condition is exceeded, the LSI may malfunction and have an adverse effect on the reliability of the LSI.

10. DC CHARACTERISTICS

Table 18

Unless otherwise specified, V<sub>SS</sub>=0 V, T<sub>a</sub>=-40 to +85°C

Item	Symbol	Condition	Specification value			Unit	Applicable pin	
			Min.	Typ.	Max.			
Operating voltage (1)	V <sub>DD</sub>	S1D15705*03**/S1D15707*03**	2.4	—	3.6	V	V <sub>DD</sub> *1	
	V <sub>DD</sub>	S1D15705*00**/S1D15707*00** /S1D15708*00**	3.6	—	5.5		V <sub>DD</sub> *1	
Operating voltage (2)	V <sub>SS2</sub>	(Based on V <sub>DD</sub> )	-6.0	—	-1.8		V <sub>SS2</sub>	
Operating voltage (3)	V <sub>5</sub>	S1D15705***** (Based on V <sub>DD</sub> )	-18.0	—	-4.5		V <sub>5</sub> *2	
	V <sub>5</sub>	S1D15707***** (Based on V <sub>DD</sub> )	-16.0	—	-4.5		V <sub>5</sub> *2	
	V <sub>5</sub>	S1D15708***** (Based on V <sub>DD</sub> )	-10.0	—	-4.5		V <sub>5</sub> *2	
	V <sub>1</sub> , V <sub>2</sub> V <sub>3</sub> , V <sub>4</sub>	(Based on V <sub>DD</sub> ) (Based on V <sub>DD</sub> )	0.4×V <sub>5</sub> V <sub>5</sub>	—	V <sub>DD</sub> 0.6×V <sub>5</sub>		V <sub>1</sub> , V <sub>2</sub> V <sub>3</sub> , V <sub>4</sub>	
High level input voltage	V <sub>IHC</sub>		0.8×V <sub>DD</sub>	—	V <sub>DD</sub>	*3		
Low level input voltage	V <sub>ILC</sub>		V <sub>SS</sub>	—	0.2×V <sub>DD</sub>	*3		
High level output voltage	V <sub>OHC</sub>	I <sub>OH</sub> =-0.5mA	0.8×V <sub>DD</sub>	—	V <sub>DD</sub>	*4		
Low level output voltage	V <sub>OLC</sub>	I <sub>OL</sub> =0.5mA	V <sub>SS</sub>	—	0.2×V <sub>DD</sub>	*4		
Input leak current	I <sub>LI</sub>	V <sub>IN</sub> =V <sub>DD</sub> or V <sub>SS</sub>	-1.0	—	1.0	μA	*5	
Output leak current	I <sub>LO</sub>		-3.0	—	3.0		*6	
Liquid crystal driver On resistance	R <sub>ON</sub>	T <sub>a</sub> =25°C	—	2.0	3.5	kΩ	SEGn COMn *7	
		(Based on V <sub>DD</sub> )	V <sub>5</sub> =-14.0V V <sub>5</sub> =-8.0V	—	3.2			5.4
Static current consumption	I <sub>SSQ</sub>		—	0.01	5	μA	V <sub>SS</sub> , V <sub>SS2</sub> V <sub>5</sub>	
Output leak current	I <sub>5Q</sub>	V <sub>5</sub> =-18.0V (Based on V <sub>DD</sub> )	—	0.01	15			
Input pin capacity	C <sub>IN</sub>	T <sub>a</sub> =25°C, f=1MHz	—	5.0	8.0	pF		
Oscillating frequency	Built-in oscillation	f <sub>OSC</sub>	T <sub>a</sub> =25°C	18	22	kHz	*8	
	External input	f <sub>CL</sub>	T <sub>a</sub> =25°C, S1D15705*****	4.5	5.5		6.5	CL *8
			T <sub>a</sub> =25°C, S1D15707*****	2.25	2.75		3.25	CL *8
			T <sub>a</sub> =25°C, S1D15708*****	1.13	1.38		1.63	CL *8

Table 19

Item	Symbol	Condition	Specification value			Unit	Applicable pin	
			Min.	Typ.	Max.			
Built-in power supply circuit	Input voltage	V <sub>SS2</sub>	At triple boosting (Based on V <sub>DD</sub> )	-6.0	—	-1.8	V	V <sub>SS2</sub>
		V <sub>SS2</sub>	At quadruple boosting (Based on V <sub>DD</sub> )	-4.5	—	-1.8		V <sub>SS2</sub>
	Boosting output voltage	V <sub>OUT</sub>	(Based on V <sub>DD</sub> )	-20.0	—	—	V <sub>OUT</sub>	
	Voltage adjusting circuit operating voltage	V <sub>OUT</sub>	(Based on V <sub>DD</sub> )	-20.0	—	-6.0	V <sub>OUT</sub>	
	V/F circuit operating voltage	V <sub>5</sub>	S1D15705***** (Based on V <sub>DD</sub> )	-18.0	—	-4.5		V <sub>5</sub> *9
			S1D15707***** (Based on V <sub>DD</sub> )	-16.0	—	-4.5		V <sub>5</sub> *9
S1D15708***** (Based on V <sub>DD</sub> )			-10.0	—	-4.5	V <sub>5</sub> *9		
Reference voltage	V <sub>REG0</sub>	T <sub>a</sub> =25°C,	-0.05%/°C	-2.04	-2.10	-2.16	*10	

[\*: see Page 61.]

## S1D15705 Series Technical Manual

**Dynamic current consumption value (1)** During display operation and built-in power supply OFF  
Current values dissipated by the whole IC when the external power supply is used

Table 20-1 Display All White

Ta=25°C

Item	Symbol	Condition	Specification value			Unit	Remarks
			Min.	Typ.	Max.		
S1D15705*00**	IDD (1)	VDD=5.0V, V5-VDD=-11.0V	—	22	37	μA	*11
S1D15705*03**		VDD=3.0V, V5-VDD=-11.0V	—	22	37		
S1D15707*00**		VDD=5.0V, V5-VDD=-8.0V		8	14		
S1D15707*03**		VDD=3.0V, V5-VDD=-8.0V		8	14		
S1D15708*00**		VDD=5.0V, V5-VDD=-6.0V		4	7		

Table 20-2 Display Checker Pattern

Ta=25°C

Item	Symbol	Condition	Specification value			Unit	Remarks
			Min.	Typ.	Max.		
S1D15705*00**	IDD (1)	VDD=5.0V, V5-VDD=-11.0V	—	33	55	μA	*11
S1D15705*03**		VDD=3.0V, V5-VDD=-11.0V	—	32	54		
S1D15707*00**		VDD=5.0V, V5-VDD=-8.0V		14	24		
S1D15707*03**		VDD=3.0V, V5-VDD=-8.0V		14	24		
S1D15708*00**		VDD=5.0V, V5-VDD=-6.0V		5	9		

**Dynamic current consumption value (2)** During display operation and built-in power supply ON  
Current values dissipated by the whole IC containing the built-in power supply circuit

Table 21-1 Display Checker Pattern

Ta=25°C

Item	Symbol	Condition		Specification value			Unit	Remarks
				Min.	Typ.	Max.		
S1D15705*00**	IDD (2)	VDD=5.0V, Triple boosting V5-VDD=-11.0V	Normal mode	—	73	122	μA	*12
			High power mode	—	216	360		
S1D15705*03**		VDD=3.0V, Quadruple boosting V5-VDD=-11.0V	Normal mode	—	92	154		
			High power mode	—	272	454		
S1D15707*00**		VDD=5.0V, Triple boosting V5-VDD=-8.0V	Normal mode	—	40	67		
			High power mode	—	171	285		
S1D15707*03**		VDD=3.0V, Quadruple boosting V5-VDD=-8.0V	Normal mode	—	51	85		
			High power mode	—	228	380		
S1D15708*00**		VDD=5.0V, Double boosting V5-VDD=-6.0V	Normal mode	—	28	47		
			High power mode	—	137	229		

[\*: see Page 61.]

Table 21-2 Display Checker Pattern

Ta=25°C

Item	Symbol	Condition		Specification value			Unit	Remarks
				Min.	Typ.	Max.		
S1D15705*00**	IDD (2)	VDD=5.0V, Triple boosting	Normal mode	—	97	162	μA	*12
		V5-VDD=-11.0V	High power mode	—	254	424		
S1D15705*03**		VDD=3.0V, Quadruple boosting	Normal mode	—	130	217		
		V5-VDD=-11.0V	High power mode	—	308	514		
S1D15707*00**		VDD=5.0V, Triple boosting	Normal mode	—	54	90		
		V5-VDD=-8.0V	High power mode	—	185	309		
S1D15707*03**		VDD=3.0V, Quadruple boosting	Normal mode	—	71	119		
		V5-VDD=-8.0V	High power mode	—	248	414		
S1D15708*00**		VDD=3.0V, Double boosting	Normal mode	—	35	59		
		V5-VDD=-6.0V	High power mode	—	144	240		

**Current consumption at power save** V<sub>SS</sub>=0 V and V<sub>DD</sub>= 3.0 V ±10% (S1D15705\*03\*\*, S1D15707\*03\*\*) 5.0V ± 10% (S1D15705\*00\*\*, S1D15707\*00\*\*, S1D15708\*00\*\*)

Table 22

Ta=25°C

Item	Symbol	Condition		Specification value			Unit	Remarks
				Min.	Typ.	Max.		
Sleep state	IDDS1	Ta=25°C		—	0.01	5	μA	
Stand-by state	IDDS2	Ta=25°C		—	4	8		

[\*: see Page 61.]

[Reference data 1]

- Dynamic current consumption (1) External power supply used and LCD being displayed

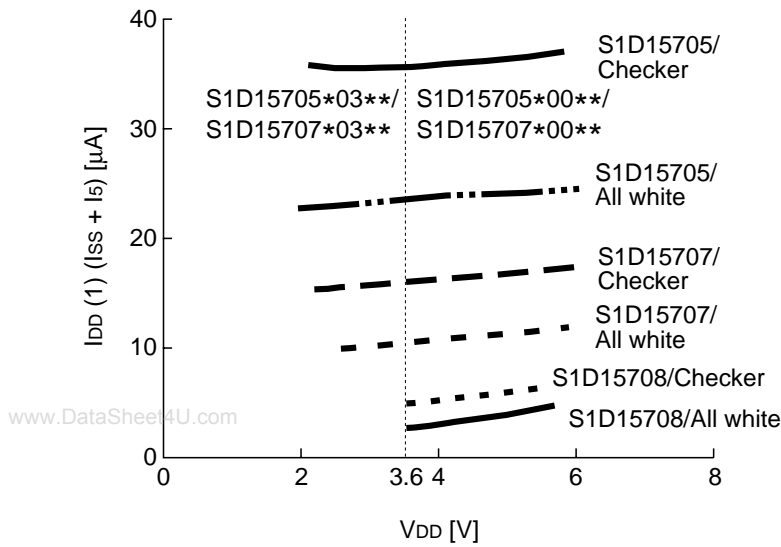

Condition: Built-in power supply OFF  
 External power supply used  
 S1D15705:  $V_5 - V_{DD} = -11.0$  V  
 S1D15707:  $V_5 - V_{DD} = -8.0$  V  
 S1D15708:  $V_5 - V_{DD} = -6.0$  V  
 Display pattern: All white/checker  
 $T_a = 25^\circ C$

Remarks: \*11

Fig. 24

[Reference data 2]

- Dynamic current consumption (2) Built-in power supply used and LCD being displayed

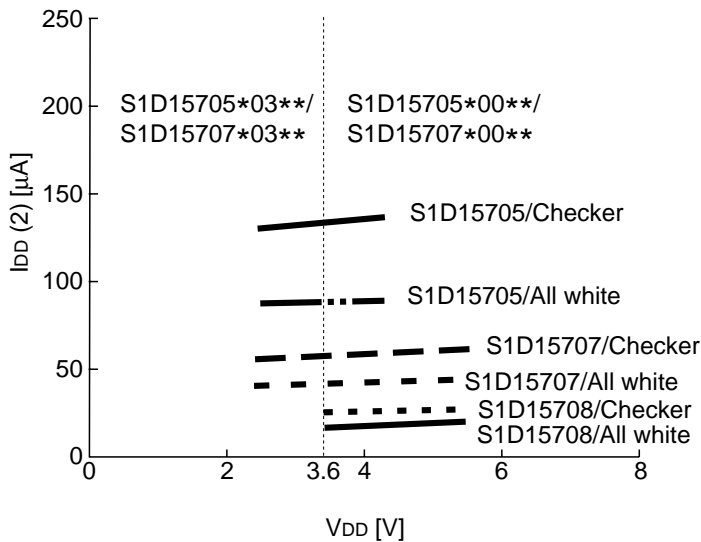

Condition: Built-in power supply ON  
 Normal mode  
 Quadruple boosting  
 S1D15705:  $V_5 - V_{DD} = -11.0$  V  
 Triple boosting  
 S1D15707:  $V_5 - V_{DD} = -8.0$  V  
 Double boosting  
 S1D15708:  $V_5 - V_{DD} = -6.0$  V  
 Display pattern: All white/checker  
 $T_a = 25^\circ C$

Remarks: \*12

Fig. 25

[\*: see page 61.]

[Reference data 3]

- Dynamic current consumption (3) During access

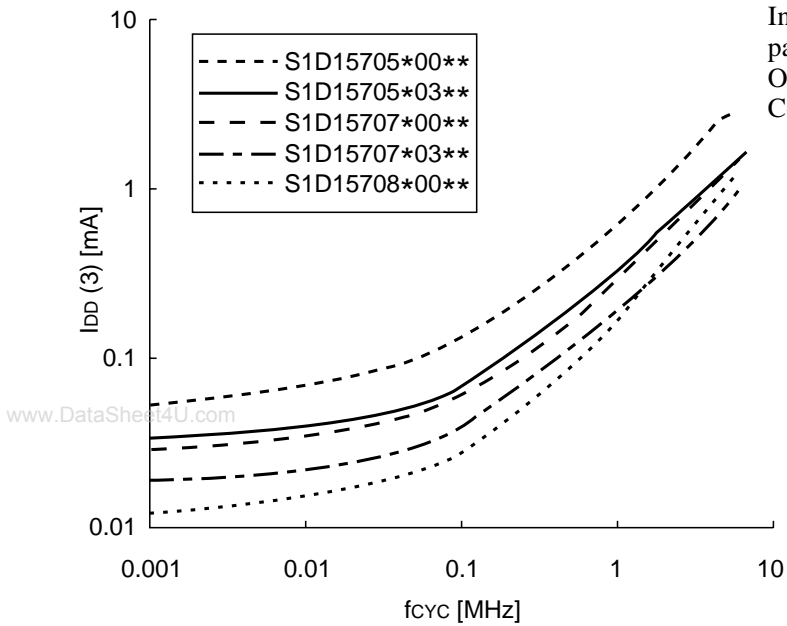

Indicates the current consumption when the checker pattern is always written at fcyc.

Only IDD (1) when not accessed

Condition: Built-in power supply OFF and external power supply used

S1D15705:

$V_5 - V_{DD} = -11.0 \text{ V}$

S1D15707:

$V_5 - V_{DD} = -11.0 \text{ V}$

S1D15705\*03\*\*/S1D15707\*03\*\*:

$V_{DD} - V_{SS} = 3.0 \text{ V}$

S1D15705\*00\*\*/S1D15707\*00\*\*

/S1D15708\*00\*\*:

$V_{DD} - V_{SS} = 5.0 \text{ V}$

$T_a = 25^\circ\text{C}$

[\*: see page 61.]

Fig. 26

[Reference data 4]

VSS and V5 system operating voltage ranges

Remarks: \*2

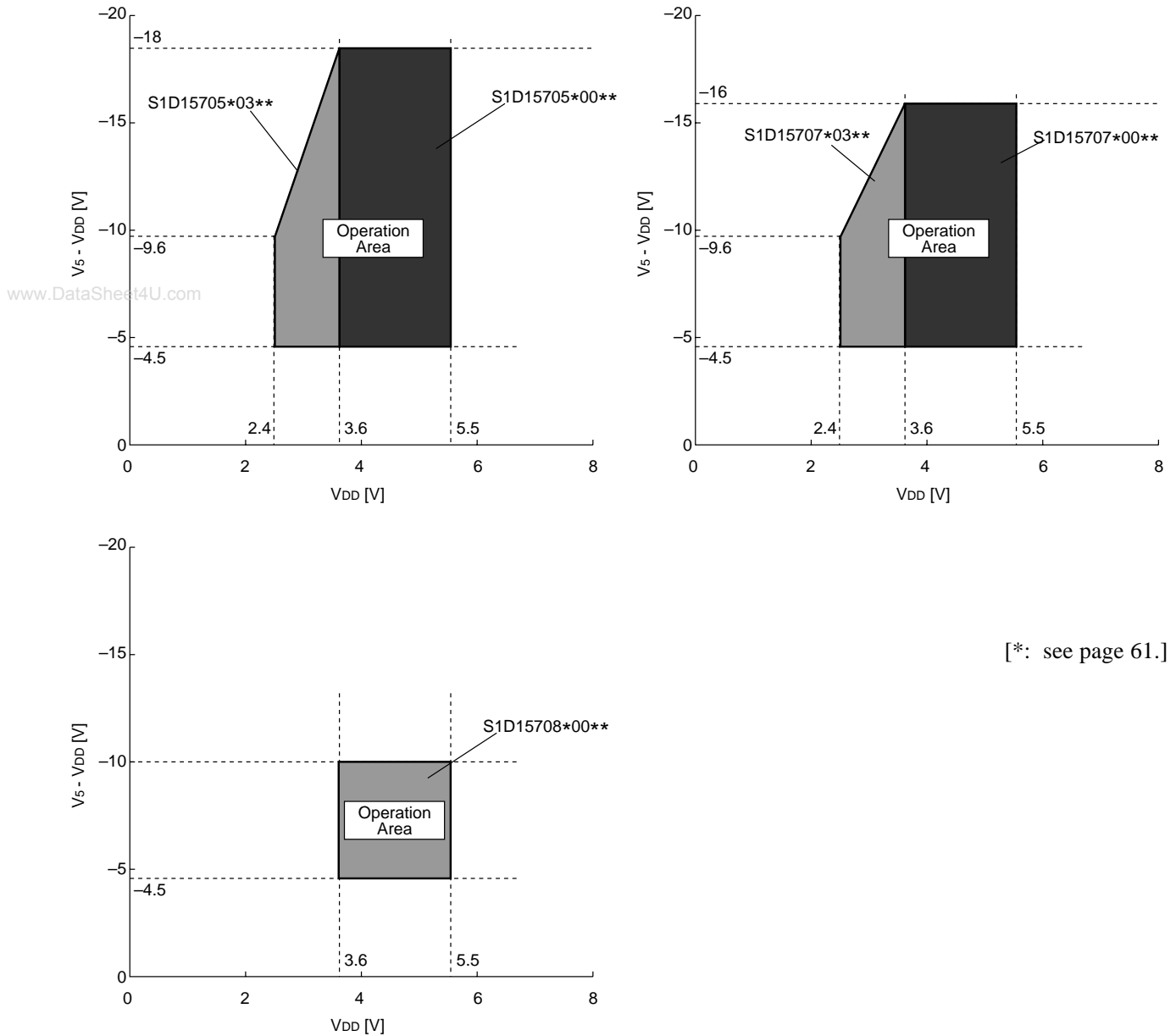

[\*: see page 61.]

Fig. 27



**Relationships between the oscillating frequency  $f_{osc}$ , display clock frequency  $f_{cl}$ , and liquid crystal frame frequency  $f_{FR}$**

Table 23

Item	fCL	fFR		
		Normal duty drive	n-line reverse drive	
S1D15705*****	When built-in oscillator circuit used	$\frac{f_{osc}}{4}$	$\frac{f_{osc}}{4.65}$	$\frac{f_{osc}}{4.n}$
	When built-in oscillator circuit not used	External input (fCL)	$\frac{f_{cl}}{65}$	$\frac{f_{cl}}{n}$
S1D15707*****	When built-in oscillator circuit used	$\frac{f_{osc}}{8}$	$\frac{f_{osc}}{8.33}$	$\frac{f_{osc}}{8.n}$
	When built-in oscillator circuit not used	External input (fCL)	$\frac{f_{cl}}{33}$	$\frac{f_{cl}}{n}$
S1D15708*****	When built-in oscillator circuit used	$\frac{f_{osc}}{16}$	$\frac{f_{osc}}{16.17}$	$\frac{f_{osc}}{16.n}$
	When built-in oscillator circuit not used	External input (fCL)	$\frac{f_{cl}}{17}$	$\frac{f_{cl}}{n}$

(fFR shows the alternating current cycle (frame cycle) of liquid crystal. The signal of FR terminal becomes twice as a frame cycle.)

[Reference items marked by \*]

- \*1 The wide operating voltage range is not warranted. However, when there is a sudden voltage change during MPU access, it cannot be warranted.
- \*2 For the VDD and V5 operating voltage ranges, see Fig. 27. These ranges are applied when using the external power supply.
- \*3 A0, D0 to D5, D6 (SCL), D7 (SI),  $\overline{RD}$  (E),  $\overline{WR}$  (R/W),  $\overline{CS1}$ , CS2, CLS, CL, FR, M/S, C86, P/S,  $\overline{DOF}$ , RES, IRS and HPM pins
- \*4 D0 to D7, FR, FRS, DOF and CL pins
- \*5 A0,  $\overline{RD}$  (E),  $\overline{WR}$  (R/W),  $\overline{CS1}$ , CS2, CLS, M/S, C86, P/S, RES, IRS and HPM pins
- \*6 Applied when D0 to D5, D6 (SCL), D7 (SI), CL, FR, and  $\overline{DOF}$  pins are in the high impedance state
- \*7 Resistance value when the 0.1 V voltage is applied between the output pin SEGn or COMn and power supply pins (V1, V2, V3, and V4). Specified within the range of operating voltage (3)  
 $R_{ON} = 0.1 \text{ V} / \Delta I$  ( $\Delta I$  indicates the current applied when 0.1 V is applied between the power ON.)
- \*8 For the relationship between the oscillating frequency and frame frequency, see Table 23. The specification value of the external input item is a recommended value.
- \*9 The V5 voltage adjusting circuit is adjusted within the voltage follower operating voltage range.
- \*10 Built-in reference voltage source of the V5 voltage adjusting circuit.
- \*11 and \*12 Indicate the current dissipated by a single IC at built-in oscillator circuit used, 1/9 bias (S1D15705\*\*\*\*\*), 1/6 bias (S1D15707\*\*\*\*\*/S1D15708\*\*\*\*\*), and display ON. Does not include the current due to the LCD panel capacity and wiring capacity. Applicable only when there is no access from the MPU.
- \*12 When the V5 voltage adjusting built-in resistor is used

Timing Characteristics

System bus read/write characteristics 1 (80 series MPU)

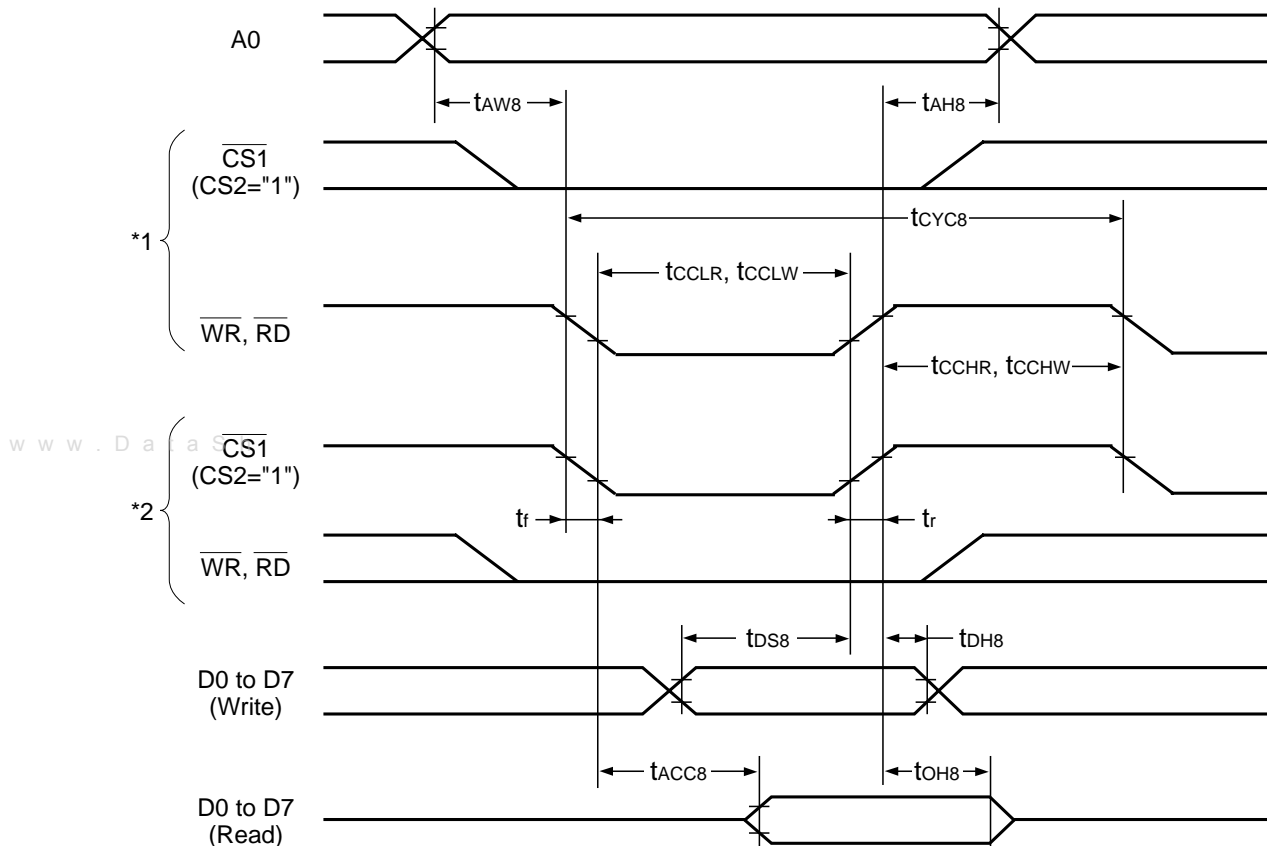

[S1D15705\*00\*\*, S1D15707\*00\*\*, S1D15708\*00\*\*: VDD=4.5V to 5.5V, Ta=-40 to +85°C]

Item	Signal	Symbol	Condition	Specification value		Unit
				Min.	Max.	
Address hold time	A0	tAH8		0	—	ns
Address setup time		tAW8		0	—	
System cycle time		tCYC8		250	—	
Control LOW pulse width (Write)	WR	tcCLW		30	—	
Control LOW pulse width (Read)	RD	tcCLR		70	—	
Control HIGH pulse width (Write)	WR	tcCHW		30	—	
Control HIGH pulse width (Read)	RD	tcCHR		30	—	
Data setup time	D0 to D7	tDS8		30	—	
Data hold time		tDH8		10	—	
RD access time		tACC8	CL=100pF	—	70	
Output disable time		tOH8		5	50	

[S1D15705\*00\*\*, S1D15707\*00\*\*, S1D15708\*00\*\*: V<sub>DD</sub>=3.6V to 4.5V, T<sub>a</sub>=-40 to +85°C]

Item	Signal	Symbol	Condition	Specification value		Unit
				Min.	Max.	
Address hold time	A0	t <sub>AH8</sub>		0	—	ns
Address setup time		t <sub>AW8</sub>		0	—	
System cycle time		t <sub>CYC8</sub>		300	—	
Control LOW pulse width (Write)	$\overline{WR}$	t <sub>CCLW</sub>		60	—	
Control LOW pulse width (Read)	$\overline{RD}$	t <sub>CCLR</sub>		120	—	
Control HIGH pulse width (Write)	$\overline{WR}$	t <sub>CCHW</sub>		60	—	
Control HIGH pulse width (Read)	$\overline{RD}$	t <sub>CCHR</sub>		60	—	
Data setup time	D0 to D7	t <sub>DS8</sub>		40	—	
Data hold time		t <sub>DH8</sub>		15	—	
$\overline{RD}$ access time		t <sub>ACC8</sub>	CL=100pF	—	280	
Output disable time	t <sub>OH8</sub>	10		100		

www.DataSheet4U.com

[S1D15705\*03\*\*, S1D15707\*03\*\*: V<sub>DD</sub>=2.4V to 3.6V, T<sub>a</sub>=-40 to +85°C]

Item	Signal	Symbol	Condition	Specification value		Unit
				Min.	Max.	
Address hold time	A0	t <sub>AH8</sub>		0	—	ns
Address setup time		t <sub>AW8</sub>		0	—	
System cycle time		t <sub>CYC8</sub>		800	—	
Control LOW pulse width (Write)	$\overline{WR}$	t <sub>CCLW</sub>		120	—	
Control LOW pulse width (Read)	$\overline{RD}$	t <sub>CCLR</sub>		240	—	
Control HIGH pulse width (Write)	$\overline{WR}$	t <sub>CCHW</sub>		120	—	
Control HIGH pulse width (Read)	$\overline{RD}$	t <sub>CCHR</sub>		120	—	
Data setup time	D0 to D7	t <sub>DS8</sub>		80	—	
Data hold time		t <sub>DH8</sub>		30	—	
$\overline{RD}$ access time		t <sub>ACC8</sub>	CL=100pF	—	280	
Output disable time	t <sub>OH8</sub>	10		200		

- \*1 This is in the case of making the access by  $\overline{WR}$  and  $\overline{RD}$ , setting the  $\overline{CS1}$ =LOW.
- \*2 This is in the case of making the access by  $\overline{CS1}$ , setting the  $\overline{WR}$ ,  $\overline{RD}$ =LOW.
- \*3 The rise and fall times (t<sub>r</sub> and t<sub>f</sub>) of the input signal are specified for less than 15 ns. When using the system cycle time at high speed, they are specified for (t<sub>r</sub>+t<sub>f</sub>) ≤ (t<sub>CYC8</sub>-t<sub>CCLW</sub>-t<sub>CCHW</sub>) or (t<sub>r</sub>+t<sub>f</sub>) ≤ (t<sub>CYC8</sub>-t<sub>CCLR</sub>-t<sub>CCHR</sub>).
- \*4 All timings are specified based on the 20 and 80% of V<sub>DD</sub>.
- \*5 t<sub>CCLW</sub> and t<sub>CCLR</sub> are specified for the overlap period when  $\overline{CS1}$  is at LOW ( $\overline{CS2}$ = HIGH) level and  $\overline{WR}$ ,  $\overline{RD}$  are at the LOW level.

System bus read/write characteristics 2 (68 series MPU)

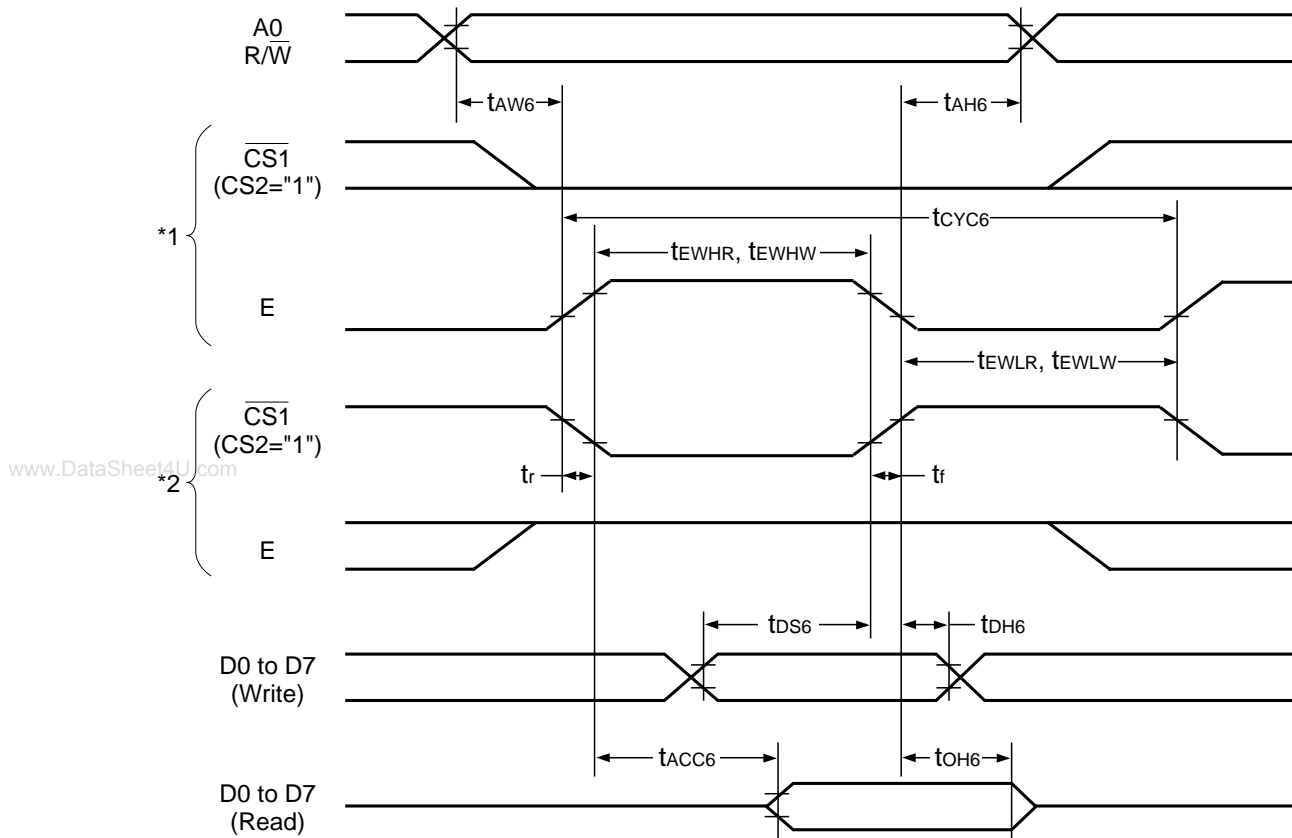

[S1D15705\*00\*\*, S1D15707\*00\*\*, S1D15708\*00\*\*: V<sub>DD</sub>=4.5V to 5.5V, T<sub>a</sub>=-40 to +85°C]

Item	Signal	Symbol	Condition	Specification value		Unit
				Min.	Max.	
Address hold time	A0	t <sub>AH6</sub>		0	—	ns
Address setup time		t <sub>AW6</sub>		0	—	
System cycle time		t <sub>CYC6</sub>		250	—	
Data setup time	D0 to D7	t <sub>DS6</sub>		30	—	
Data hold time		t <sub>DH6</sub>		10	—	
Access time		t <sub>ACC6</sub>	C <sub>L</sub> =100pF	—	70	
Output disable time		t <sub>OH6</sub>		5	50	
Enable HIGH pulse width	Read	E	t <sub>EWHR</sub>	70	—	
	Write	E	t <sub>EWHW</sub>	30	—	
Enable LOW pulse width	Read	E	t <sub>EWLR</sub>	30	—	
	Write	E	t <sub>EWLW</sub>	30	—	

[S1D15705\*00\*\*, S1D15707\*00\*\*, S1D15708\*00\*\*: V<sub>DD</sub>=3.6V to 4.5V, T<sub>a</sub>=-40 to +85°C]

Item	Signal	Symbol	Condition	Specification value		Unit
				Min.	Max.	
Address hold time	A0	t <sub>AH6</sub>		0	—	ns
Address setup time		t <sub>AW6</sub>		0	—	
System cycle time		t <sub>CYC6</sub>		300	—	
Data setup time	D0 to D7	t <sub>DS6</sub>		40	—	
Data hold time		t <sub>DH6</sub>		15	—	
Access time		t <sub>ACC6</sub>	CL=100pF	—	140	
Output disable time		t <sub>OH6</sub>		10	100	
Enable HIGH pulse width	Read Write	E	t <sub>EWHR</sub>	120	—	
			t <sub>EWHW</sub>	60	—	
Enable LOW pulse width	Read Write	E	t <sub>EWLR</sub>	60	—	
			t <sub>EWLW</sub>	60	—	

[S1D15705\*03\*\*, S1D15707\*03\*\*: V<sub>DD</sub>=2.4V to 3.6V, T<sub>a</sub>=-40 to +85°C]

www.DataSheet4U.com

Item	Signal	Symbol	Condition	Specification value		Unit
				Min.	Max.	
Address hold time	A0	t <sub>AH6</sub>		0	—	ns
Address setup time		t <sub>AW6</sub>		0	—	
System cycle time		t <sub>CYC6</sub>		800	—	
Data setup time	D0 to D7	t <sub>DS6</sub>		80	—	
Data hold time		t <sub>DH6</sub>		30	—	
Access time		t <sub>ACC6</sub>	CL=100pF	—	280	
Output disable time		t <sub>OH6</sub>		10	200	
Enable HIGH pulse width	Read Write	E	t <sub>EWHR</sub>	240	—	
			t <sub>EWHW</sub>	120	—	
Enable LOW pulse width	Read Write	E	t <sub>EWLR</sub>	120	—	
			t <sub>EWLW</sub>	120	—	

- \*1 This is in the case of making the access by  $\overline{E}$ , setting the  $\overline{CS1}$ =LOW.
- \*2 This is in the case of making the access by CS<sub>1</sub>, setting the E=HIGH.
- \*3 The rise and fall times (t<sub>r</sub> and t<sub>f</sub>) of the input signal are specified for less than 15 ns. When using the system cycle time at high speed, they are specified for (t<sub>r</sub>+t<sub>f</sub>) ≤ (t<sub>CYC6</sub>-t<sub>EWLW</sub>-t<sub>EWHW</sub>) or (t<sub>r</sub>+t<sub>f</sub>) ≤ (t<sub>CYC6</sub>-t<sub>EWLR</sub>-t<sub>EWHR</sub>).
- \*4 All timings are specified based on the 20 and 80% of V<sub>DD</sub>.
- \*5 t<sub>EWLW</sub> and t<sub>EWLR</sub> are specified for the overlap period when  $\overline{CS1}$  is at LOW (CS<sub>2</sub>= HIGH) level and E is at the HIGH level.

Serial interface

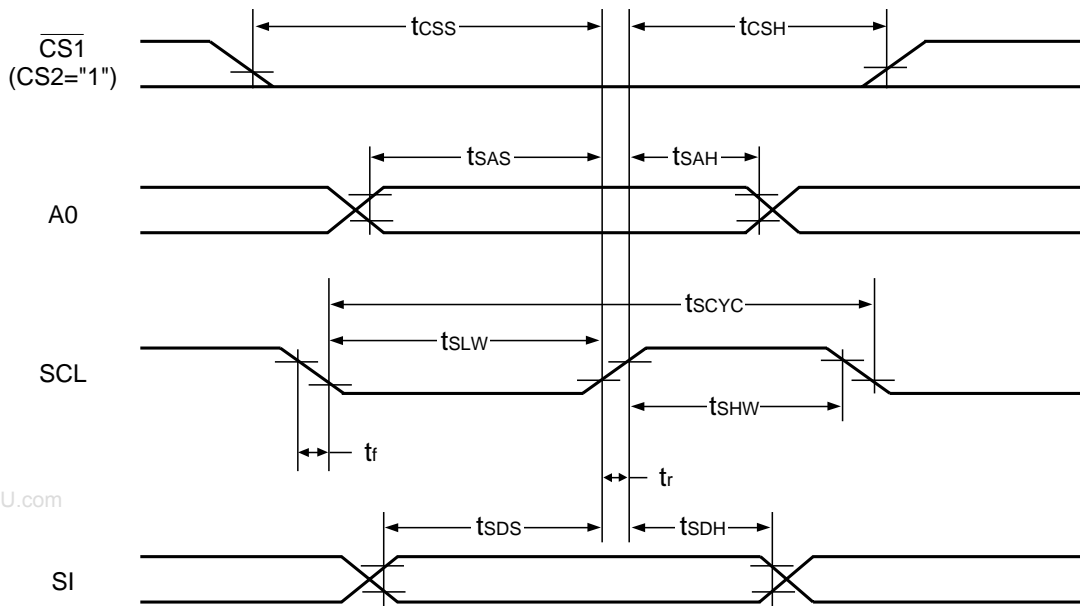

www.DataSheet4U.com

[S1D15705\*00\*\*, S1D15707\*00\*\*, S1D15708\*00\*\*: V<sub>DD</sub>=4.5V to 5.5V, T<sub>a</sub>=-40 to +85°C]

Item	Signal	Symbol	Condition	Specification value		Unit
				Min.	Max.	
Serial clock cycle	SCL	tSCYC		200	—	ns
SCL HIGH pulse width		tSHW		75	—	
SCL LOW pulse width		tSLW		75	—	
Address setup time	A0	tsAS		50	—	
Address hold time		tsAH		100	—	
Data setup time	SI	tSDS		50	—	
Data hold time		tSDH		50	—	
CS-SCL time	CS	tCSS		100	—	
		tCSH		100	—	

[S1D15705\*00\*\*, S1D15707\*00\*\*, S1D15708\*00\*\*: V<sub>DD</sub>=3.6V to 4.5V, T<sub>a</sub>=-40 to +85°C]

Item	Signal	Symbol	Condition	Specification value		Unit
				Min.	Max.	
Serial clock cycle	SCL	tSCYC		250	—	ns
SCL HIGH pulse width		tSHW		100	—	
SCL LOW pulse width		tSLW		100	—	
Address setup time	A0	tSAS		150	—	
Address hold time		tSAH		150	—	
Data setup time	SI	tSDS		100	—	
Data hold time		tSDH		100	—	
CS-SCL time	CS	tCSS		150	—	
		tCSH		150	—	

[S1D15705\*03\*\*, S1D15707\*03\*\*: V<sub>DD</sub>=2.4V to 3.6V, T<sub>a</sub>=-40 to +85°C]

www.DataSheet4U.com

Item	Signal	Symbol	Condition	Specification value		Unit
				Min.	Max.	
Serial clock cycle	SCL	tSCYC		400	—	ns
SCL HIGH pulse width		tSHW		150	—	
SCL LOW pulse width		tSLW		150	—	
Address setup time	A0	tSAS		250	—	
Address hold time		tSAH		250	—	
Data setup time	SI	tSDS		150	—	
Data hold time		tSDH		150	—	
CS-SCL time	CS	tCSS		250	—	
		tCSH		250	—	

\*1 The rise and fall times (t<sub>r</sub> and t<sub>f</sub>) of the input signal are specified for less than 15 ns.

\*2 All timings are specified based on the 20 and 80% of V<sub>DD</sub>.

Display control output timing

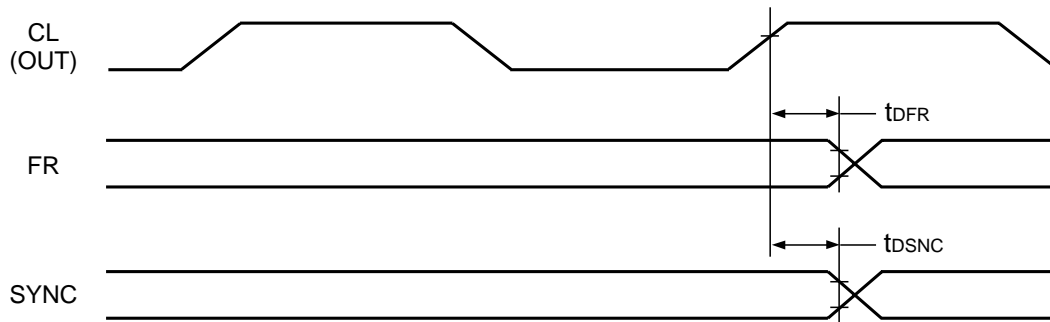

[S1D15705\*00\*\*, S1D15707\*00\*\*, S1D15708\*00\*\*: V<sub>DD</sub>=4.5V to 5.5V, T<sub>a</sub>=-40 to +85°C]

Item	Signal	Symbol	Condition	Specification value			Unit
				Min.	Typ.	Max.	
FR delay time	FR	tDFR	CL=50pF	—	10	40	ns
SYNC delay time	SYNC	tDSNC	CL=50pF	—	10	40	ns

[S1D15705\*00\*\*, S1D15707\*00\*\*, S1D15708\*00\*\*: V<sub>DD</sub>=3.6V to 4.5V, T<sub>a</sub>=-40 to +85°C]

Item	Signal	Symbol	Condition	Specification value			Unit
				Min.	Typ.	Max.	
FR delay time	FR	tDFR	CL=50pF	—	20	80	ns
SYNC delay time	SYNC	tDSNC	CL=50pF	—	20	80	ns

[S1D15705\*03\*\*, S1D15707\*03\*\*: V<sub>DD</sub>=2.4V to 3.6V, T<sub>a</sub>=-40 to +85°C]

Item	Signal	Symbol	Condition	Specification value			Unit
				Min.	Typ.	Max.	
FR delay time	FR	tDFR	CL=50pF	—	50	200	ns
SYNC delay time	SYNC	tDSNC	CL=50pF	—	50	200	ns

- \*1 Valid only when the master mode is selected.
- \*2 All timings are specified based on the 20 and 80% of V<sub>DD</sub>.
- \*3 Pay attention not to cause delays of the timing signals CL, FR and SYNC to the salve side by wiring resistance, etc., while master/slave operations are in progress. If these delays occur, indication failures such as flickering may occur.



Reset input timing

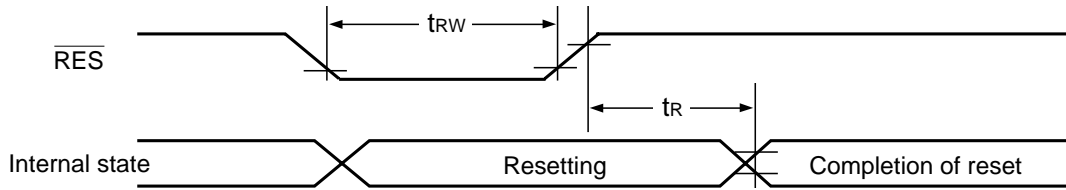

[S1D15705\*00\*\*, S1D15707\*00\*\*, S1D15708\*00\*\*: V<sub>DD</sub>=4.5V to 5.5V, T<sub>a</sub>=-40 to +85°C]

Item	Signal	Symbol	Condition	Specification value			Unit
				Min.	Typ.	Max.	
Reset time		t <sub>R</sub>		—	—	0.5	μs
Reset LOW pulse width	RES	t <sub>RW</sub>		0.5	—	—	

www.DataSheet4U.com

[S1D15705\*00\*\*, S1D15707\*00\*\*, S1D15708\*00\*\*: V<sub>DD</sub>=3.6V to 4.5V, T<sub>a</sub>=-40 to +85°C]

Item	Signal	Symbol	Condition	Specification value			Unit
				Min.	Typ.	Max.	
Reset time		t <sub>R</sub>		—	—	1	μs
Reset LOW pulse width	RES	t <sub>RW</sub>		1	—	—	

[S1D15705\*03\*\*, S1D15707\*03\*\*: V<sub>DD</sub>=2.4V to 3.6V, T<sub>a</sub>=-40 to +85°C]

Item	Signal	Symbol	Condition	Specification value			Unit
				Min.	Typ.	Max.	
Reset time		t <sub>R</sub>		—	—	1.5	μs
Reset LOW pulse width	RES	t <sub>RW</sub>		1.5	—	—	

\*1 All timings are specified based on the 20 and 80% of V<sub>DD</sub>.

### 11. MICROPROCESSOR (MPU) INTERFACE: REFERENCE

The S1D15705 series can directly be connected to the 80 system MPU and 68 series MUP. It can also be operated with a fewer signal lines by using the serial interface.

The S1D15705 series is used for the multiple chip configuration to expand the display area. In this case, it can select the ICs that are accessed individually using the Chip Select signal.

After the initialization using the RES pin, the respective input pins of the S1D15705 series need to be controlled normally.

#### 80 series MPU

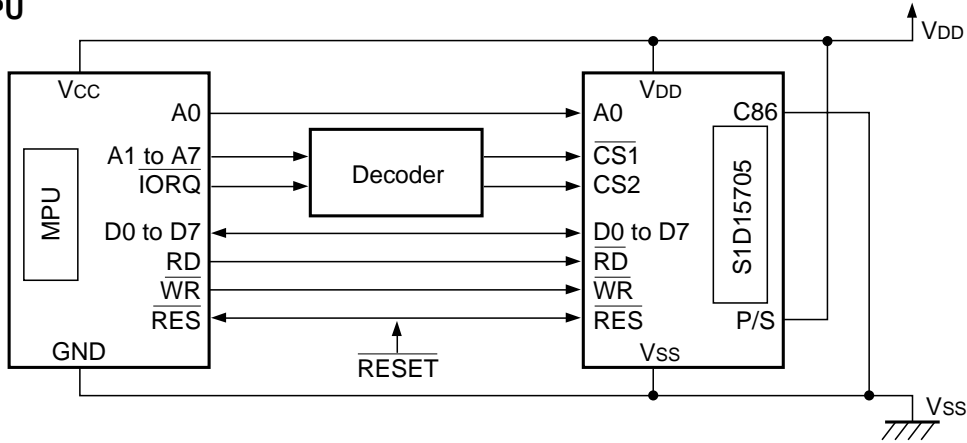

#### 68 series MPU

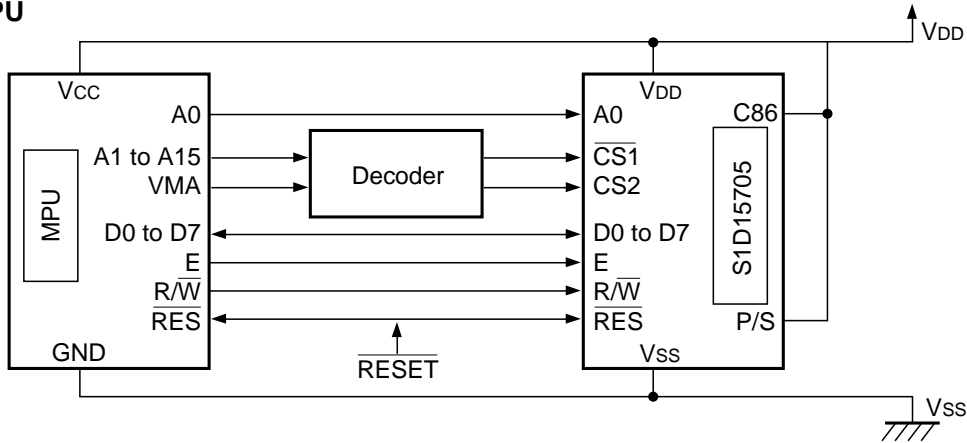

#### Serial interface

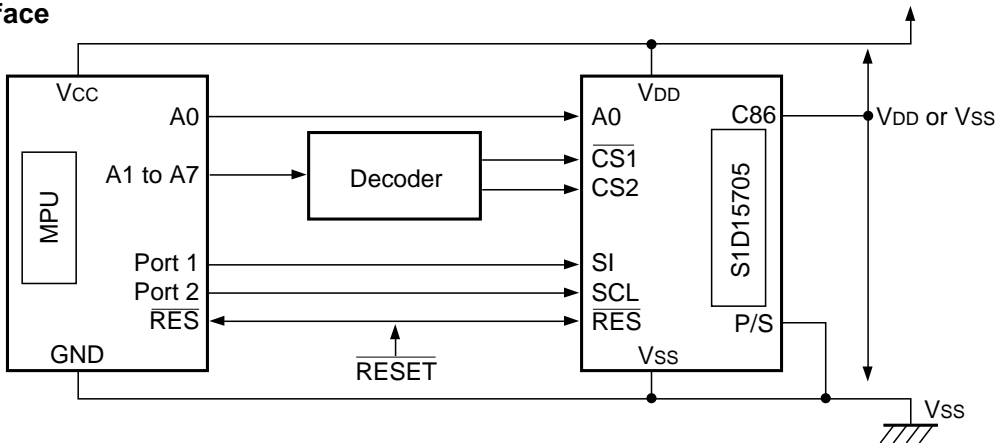

## 12. CONNECTION BETWEEN LCD DRIVERS: REFERENCE

The S1D15705 series is used for the multiple chip configuration to easily expand the liquid crystal display area. Use the same device (S1D15705\*\*\*\*\*/S1D15705\*\*\*\*\*, S1D15707\*\*\*\*\*/S1D15707\*\*\*\*\*, or S1D15708\*\*\*\*\*/S1D15708\*\*\*\*\*) for the master/slave.

### S1D15705 (master) ↔ S1D15705 (slave)

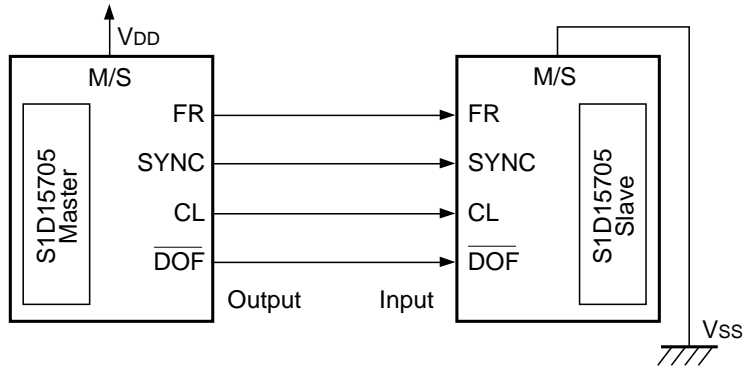

www.DataSheet4U.com

### 13. LCD PANEL WIRING: REFERENCE

The S1D15705 series is used for the multiple chip configuration to easily expand the liquid crystal display area. Use the same device (S1D15705\*\*\*\*\*/S1D15705\*\*\*\*\*, S1D15707\*\*\*\*\*/S1D15707\*\*\*\*\*, or S1D15708\*\*\*\*\*/S1D15708\*\*\*\*\*) for the multiple chip configuration.

#### 1-chip configuration

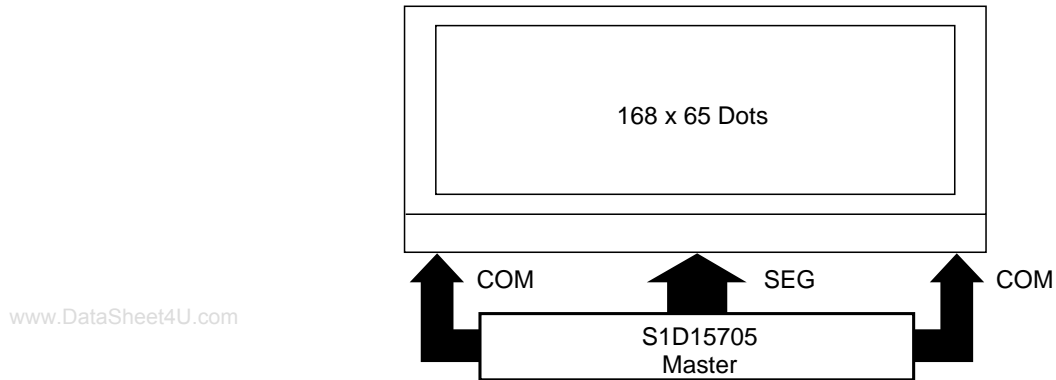

#### 2-chip configuration

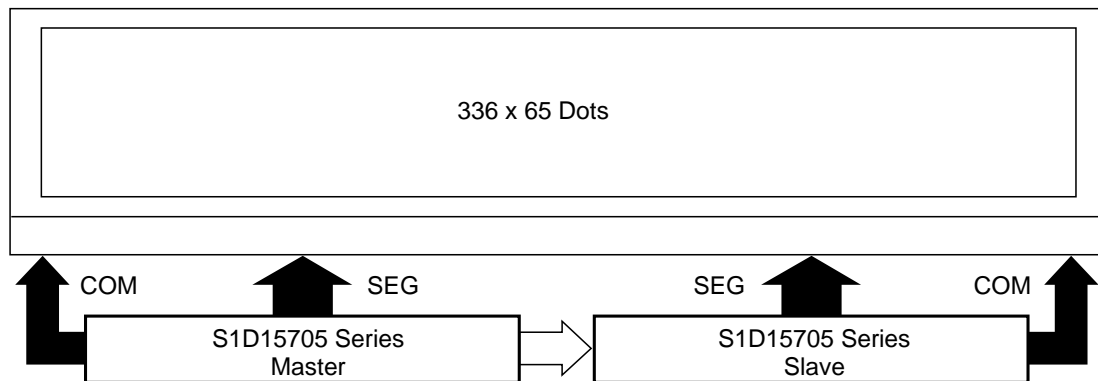

14. TCP PIN LAYOUT

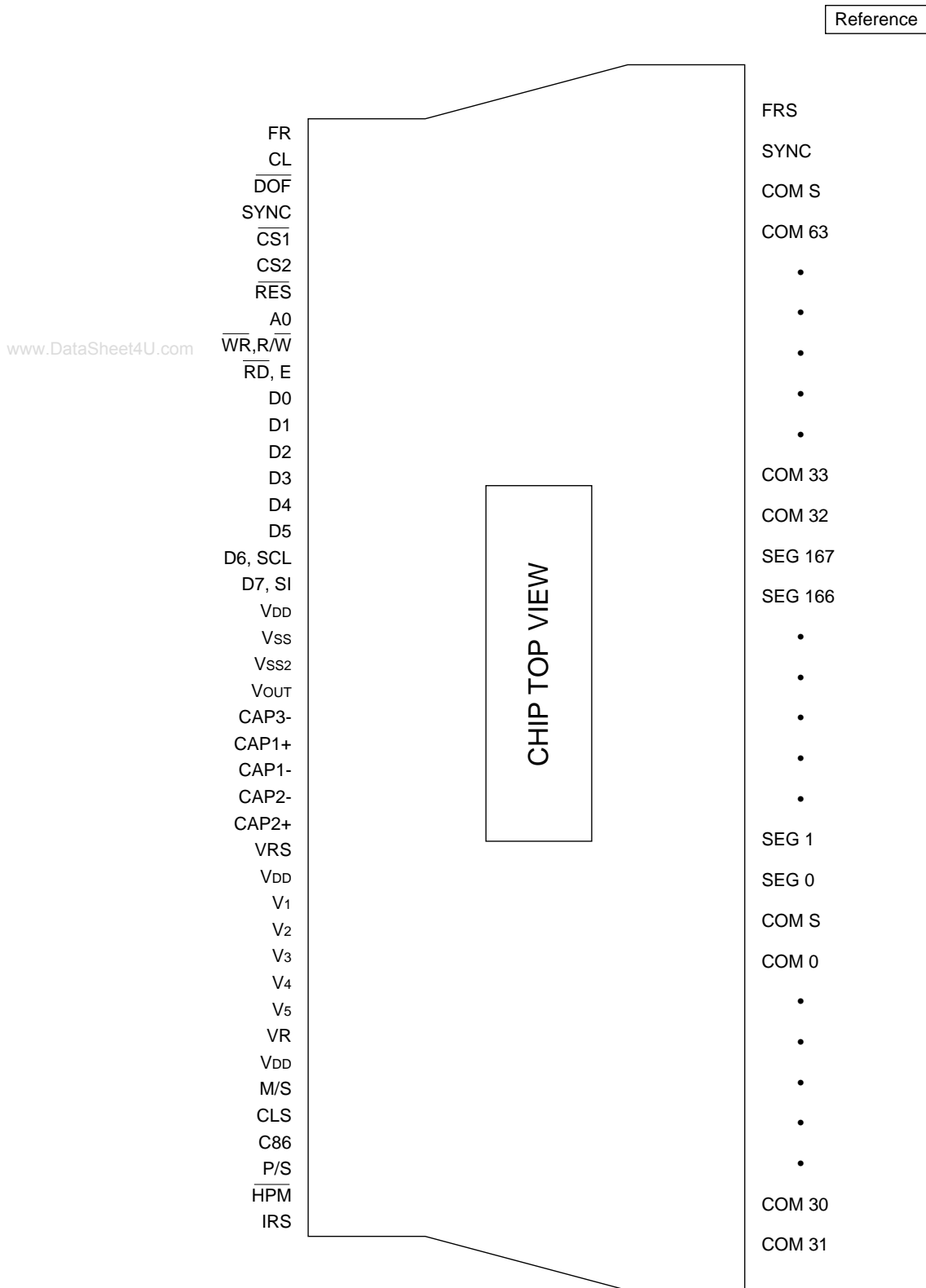

Note) This TCP pin layout does not specify the TCP dimensions.

15. TCP DIMENSIONS

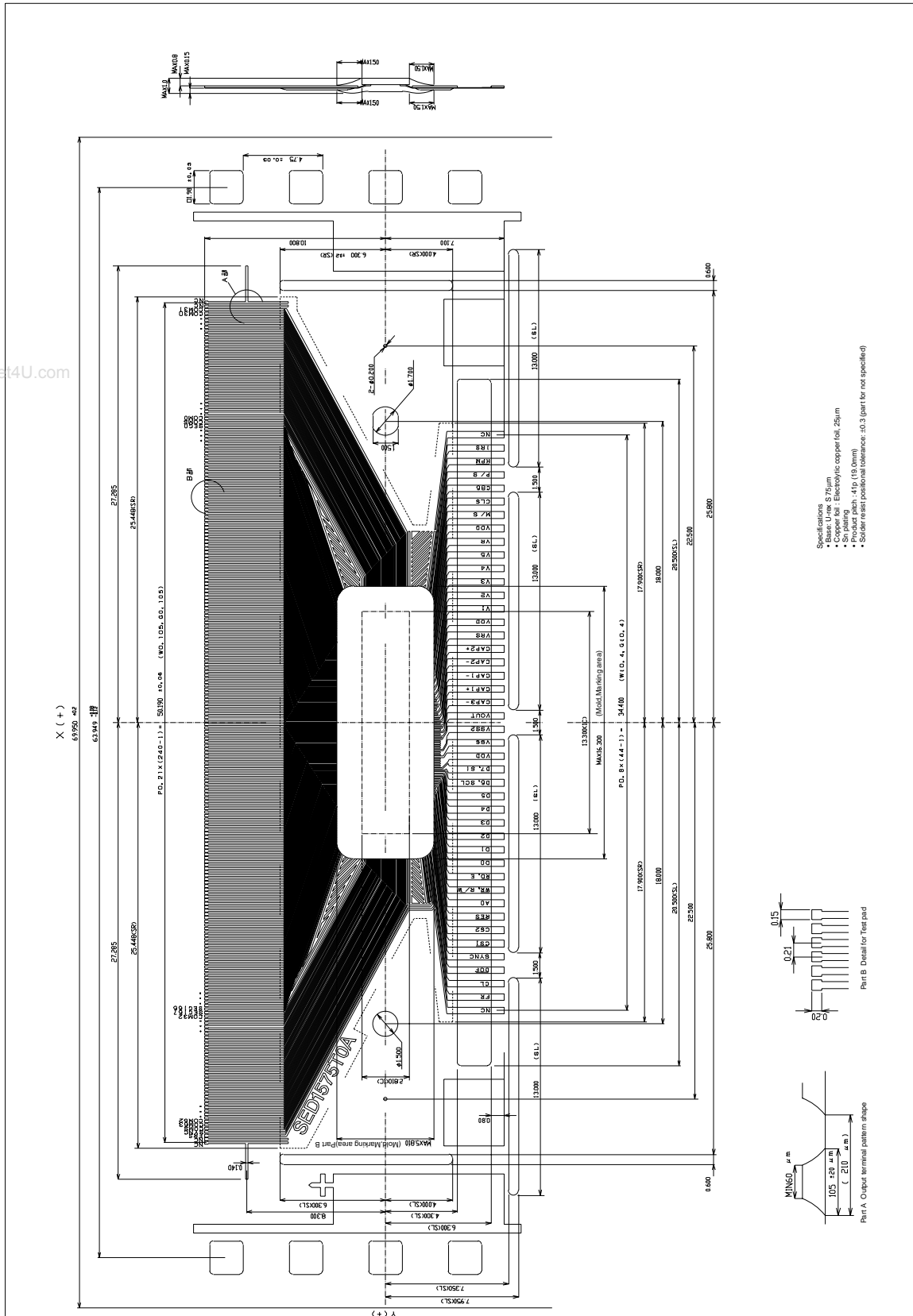

www.DataSheet4U.com

## 16. TEMPERATURE SENSOR CIRCUIT

S1D15705\*10\*\* incorporates a temperature sensor circuit with a 11.4mV/°C (typ.) temperature gradient carrying analog voltage output pins. The S1D15705\*10\*\* makes it possible to provide LCD indications with optimum contrast throughout a wide temperature range without need for use of supplementary parts by inputting electronic volume control registration value equivalent signals corresponding to the outputs of the temperature sensor through the MPU to control the LCD drive voltage V<sub>5</sub>.

For LCD drive voltage controls of higher precision, we recommend you to constitute a system which can absorb deviations of the output voltage by, such as, feeding back sampled output voltages under a certain temperature environment to the MPU to let it memorize as the reference voltages.

Regarding the specifications of other items than the temperature sensor circuit, such as of the absolute maximum ratings, DC characteristics, AC characteristics, etc., refer to the specifications for S1D15705\*00\*\*.

### Pin Definitions

Temperature sensor circuit related pins are allocated to TEST1, 2, 3 and 4 and the pin names are TEST1, SVS, VSEN, SEN and SENSEL in the given sequence. The temperature sensor should be used under the pin statuses indicated in the Table below. When the temperature sensor is not being used, fix respective pins to HIGH.

Pin names	I/O	Pin definitions	Number of pins
SVS	Power supply	This is the power supply pin for the temperature sensor. Apply prescribed operating voltage between the V <sub>DD</sub> .	1
VSEN	O	This is the analog voltage output pin for the temperature sensor. Monitor the output voltage between the V <sub>DD</sub> .	1
SEN	O	Consider to keep this pin open in order not to apply the load capacitance of wires, etc.	1
SENSEL	I	Fix this pin to HIGH.	1

### Electric Characteristics

Items	Codes	Conditions	Specifications			Units	Applicable pins
			Min.	Typ.	Max.		
Operating voltage	SVS	(On the basis of V <sub>DD</sub> )	-5.5	-5.0	-4.5	V	SVS
Output voltage	VSEN	(On the basis of V <sub>DD</sub> ) Ta = 40°C	-4.35	-3.62	-2.89	V	VSEN
		(On the basis of V <sub>DD</sub> ) Ta = 25°C	-3.48	-2.88	-2.28		
		(On the basis of V <sub>DD</sub> ) Ta = 85°C	-2.92	-2.20	-1.47		
Output voltage temperature gradient	VGRA	*1	9.4	11.4	13.4	mV/°C	VSEN
Output voltage linearity	ΔVL	*2	-1.5	—	1.5	%	VSEN
Output voltage setup time	t <sub>SEN</sub>	*3	100	—	—	mS	VSEN
Operating current	I <sub>SEN</sub>	Ta = 25°C	—	40	150	μA	SVS

[\* Notes]

\*1: Represents the gradient of the approximate line of the Typ. output voltages.

\*2: Represents the maximum deviation between the output voltage curve and the approximate line.

Assuming that the difference of output voltages at  $-40^{\circ}\text{C}$  and at  $80^{\circ}\text{C}$  as  $\Delta V_{\text{SEN}}$ , assuming that the difference between the approximate line and the output voltage values as  $\Delta V_{\text{DIFF}}$  and assuming that the maximum value thereof as  $\Delta V_{\text{DIFF}}(\text{MAX})$ , the output voltages linearity  $\Delta V_L$  can be calculated by use of the following equation.

$$\Delta V_L = \frac{\Delta V_{\text{DIFF}}(\text{MAX})}{\Delta V_{\text{SEN}}} \times 100$$

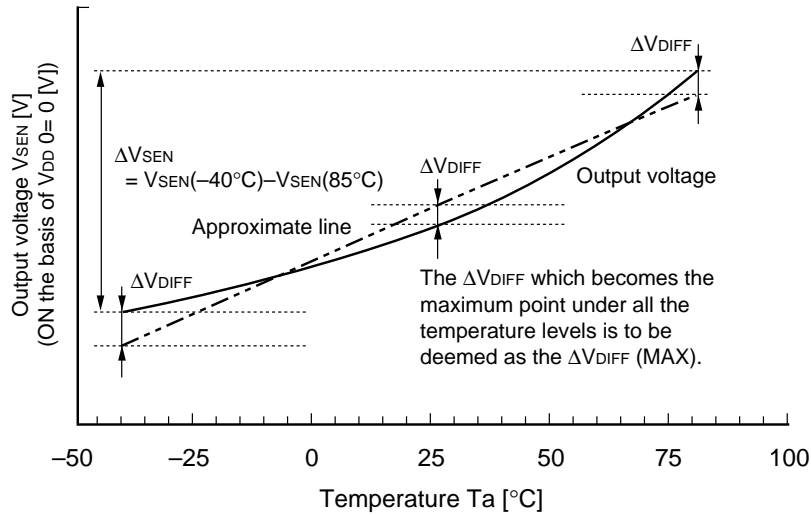

www.DataSheet4U.com

\*3: Represents the queuing time after the supply voltage SVS is applied to the SVS pin until the output voltage is stabilized and monitoring thereof becomes feasible. Be sure to sample the output voltage after the prescribed queuing time has elapsed.

**Output voltage characteristics**

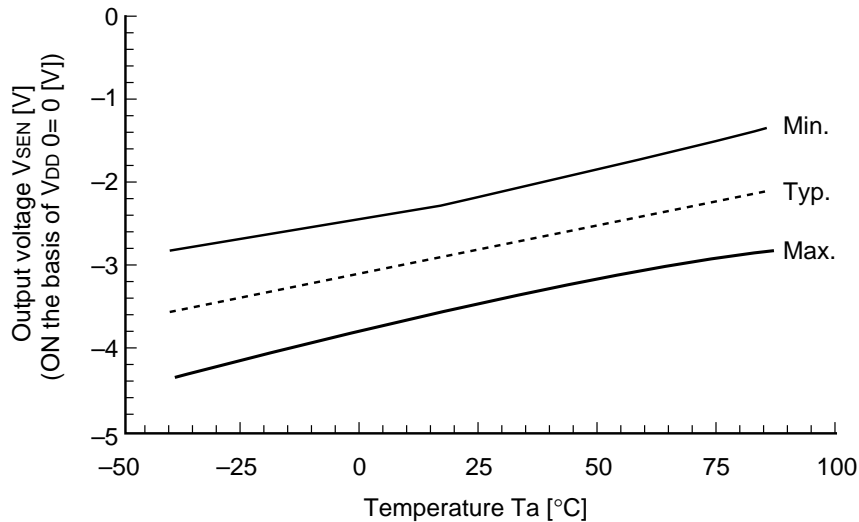



## Output Pin Load

Maintain the load capacity  $C_L$  for the VSEN output pin VSEN at 100pF or less and keep the load resistance  $R_L$  for the VSEN output pin VSEN at  $1M\Omega$  or more.

In order to obtain accurate output voltage values, be careful not to insert a current flowing channel between the VSS.

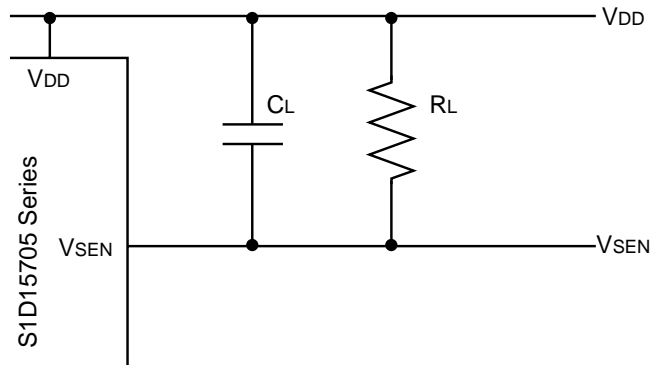

www.DataSheet4U.com

### 17. CAUTIONS

Cautions must be exercised on the following points when using this Development Specification:

1. This Development Specification is subject to change for engineering improvement.
2. This Development Specification does not guarantee execution of the industrial proprietary rights or other rights, or grant a license. Examples of applications described in This Development Specification are intended for your understanding of the Product. We are not responsible for any circuit problem or the like arising from the use of them.
3. Reproduction or copy of any part or whole of this Development Specification without permission of our company, or use thereof for other business purposes is strictly prohibited.

For the use of the semi-conductor,cautions must be exercised on the following points:

#### [Cautions against Light]

The semiconductor will be subject to changes in characteristics when light is applied. If this IC is exposed to light, operation error may occur. To protect the IC against light, the following points should be noted regarding the substrate or product where this IC is mounted:

- (1) Designing and mounting must be provided to get a structure which ensures a sufficient resistance of the IC to light in practical use.
- (2) In the inspection process, environmental configuration must be provided to ensure a sufficient resistance of the IC to light.
- (3) Means must be taken to ensure resistance to light on all the surfaces, backs and sides of the IC

### AMERICA

#### EPSON ELECTRONICS AMERICA, INC.

##### HEADQUARTERS

150 River Oaks Parkway  
San Jose, CA 95134, U.S.A.  
Phone: +1-800-228-3964      FAX: +1-408-922-0238

##### SALES OFFICES

###### West

1960 E. Grand Avenue Flr 2  
El Segundo, CA 90245, U.S.A.  
Phone: +1-800-249-7730      FAX: +1-310-955-5400

###### Central

101 Virginia Street, Suite 290  
Crystal Lake, IL 60014, U.S.A.  
Phone: +1-800-853-3588      FAX: +1-815-455-7633

###### Northeast

301 Edgewater Place, Suite 210  
Wakefield, MA 01880, U.S.A.  
Phone: +1-800-922-7667      FAX: +1-781-246-5443

###### Southeast

3010 Royal Blvd. South, Suite 170  
Alpharetta, GA 30005, U.S.A.  
Phone: +1-877-332-0020      FAX: +1-770-777-2637

### EUROPE

#### EPSON EUROPE ELECTRONICS GmbH

##### HEADQUARTERS

Riesstrasse 15  
80992 Munich, GERMANY  
Phone: +49-89-14005-0      FAX: +49-89-14005-110

##### DÜSSELDORF BRANCH OFFICE

Altstadtstrasse 176  
51379 Leverkusen, GERMANY  
Phone: +49-2171-5045-0      FAX: +49-2171-5045-10

##### FRENCH BRANCH OFFICE

1 Avenue de l'Atlantique, LP 915 Les Conquerants  
Z.A. de Courtaboeuf 2, F-91976 Les Ulis Cedex, FRANCE  
Phone: +33-1-64862350      FAX: +33-1-64862355

##### BARCELONA BRANCH OFFICE

###### Barcelona Design Center

Edificio Testa, C/Alcalde Barnils 64-68, Modulo C 2a planta  
E-08190 Sant Cugat del Vallès, SPAIN  
Phone: +34-93-544-2490      FAX: +34-93-544-2491

##### UK & IRELAND BRANCH OFFICE

8 The Square, Stockley Park, Uxbridge  
Middx UB11 1FW, UNITED KINGDOM  
Phone: +44-1295-750-216/+44-1342-824451  
FAX: +44-89-14005 446/447

##### Scotland Design Center

Integration House, The Alba Campus  
Livingston West Lothian, EH54 7EG, SCOTLAND  
Phone: +44-1506-605040      FAX: +44-1506-605041

### ASIA

#### EPSON (CHINA) CO., LTD.

23F, Beijing Silver Tower 2# North RD DongSanHuan  
ChaoYang District, Beijing, CHINA  
Phone: +86-10-6410-6655      FAX: +86-10-6410-7320

##### SHANGHAI BRANCH

7F, High-Tech Bldg., 900, Yishan Road,  
Shanghai 200233, CHINA  
Phone: +86-21-5423-5522      FAX: +86-21-5423-5512

##### EPSON HONG KONG LTD.

20/F., Harbour Centre, 25 Harbour Road  
Wanchai, Hong Kong  
Phone: +852-2585-4600      FAX: +852-2827-4346  
Telex: 65542 EPSCO HX

##### EPSON Electronic Technology Development (Shenzhen) LTD.

12/F, Dawning Mansion, Keji South 12th Road,  
Hi-Tech Park, Shenzhen  
Phone: +86-755-2699-3828      FAX: +86-755-2699-3838

##### EPSON TAIWAN TECHNOLOGY & TRADING LTD.

14F, No. 7, Song Ren Road,  
Taipei 110  
Phone: +886-2-8786-6688      FAX: +886-2-8786-6677

##### HSINCHU OFFICE

No. 99, Jiangong Road,  
Hsinchu City 300  
Phone: +886-3-573-9900      FAX: +886-3-573-9169

##### EPSON SINGAPORE PTE., LTD.

1 HarbourFront Place,  
#03-02 HarbourFront Tower One, Singapore 098633  
Phone: +65-6586-5500      FAX: +65-6271-3182

##### SEIKO EPSON CORPORATION

###### KOREA OFFICE

50F, KLI 63 Bldg., 60 Yoido-dong  
Youngdeungpo-Ku, Seoul, 150-763, KOREA  
Phone: +82-2-784-6027      FAX: +82-2-767-3677

###### GUMI OFFICE

2F, Grand B/D, 457-4 Songjeong-dong,  
Gumi-City, KOREA  
Phone: +82-54-454-6027      FAX: +82-54-454-6093

##### SEIKO EPSON CORPORATION

###### SEMICONDUCTOR OPERATIONS DIVISION

###### IC Sales Dept.

###### IC Marketing Group

421-8, Hino, Hino-shi, Tokyo 191-8501, JAPAN  
Phone: +81-42-587-5814      FAX: +81-42-587-5117