

# S1PDB72

## Single Phase Bridge Rectifiers Modules

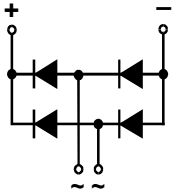
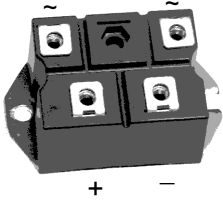

Type	$V_{RSM}$ V	$V_{RRM}$ V
S1PDB72N08	900	800
S1PDB72N10	1100	1000
S1PDB72N12	1300	1200
S1PDB72N14	1500	1400
S1PDB72N16	1700	1600
S1PDB72N18	1900	1800

Dimensions in mm (1mm=0.0394")

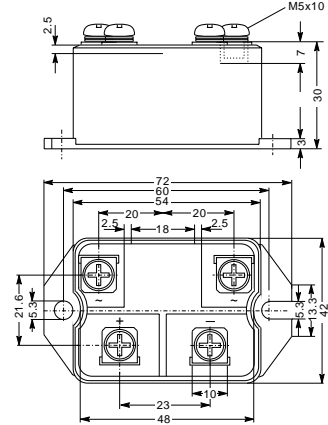

Symbol	Test Conditions	Maximum Ratings	Unit
$I_{dav}$	$T_C=100^{\circ}C$ , module	72	A
$I_{dav}$	$T_A=45^{\circ}C$ ( $R_{thCA}=0.6K/W$ ), module	49	
$I_{FSM}$	$T_{VJ}=45^{\circ}C$ $V_R=0$ $t=10ms$ (50Hz), sine $t=8.3ms$ (60Hz), sine	750 820	A
	$T_{VJ}=T_{VJM}$ $V_R=0$ $t=10ms$ (50Hz), sine $t=8.3ms$ (60Hz), sine	670 740	
$I^2t$	$T_{VJ}=45^{\circ}C$ $V_R=0$ $t=10ms$ (50Hz), sine $t=8.3ms$ (60Hz), sine	2800 2800	$A^2s$
	$T_{VJ}=T_{VJM}$ $V_R=0$ $t=10ms$ (50Hz), sine $t=8.3ms$ (60Hz), sine	2250 2250	
$T_{vJ}$ $T_{vJM}$ $T_{stg}$		-40...+150 150 -40...+125	$^{\circ}C$
$V_{ISOL}$	50/60Hz, RMS $I_{ISOL} \leq 1mA$ $t=1min$ $t=1s$	2500 3000	V~
$M_d$	Mounting torque (M5) Terminal connection torque (M5)	$5 \pm 15\%$ $5 \pm 15\%$	Nm
Weight	typ.	160	g

# S1PDB72

## Single Phase Bridge Rectifiers Modules

Symbol	Test Conditions	Characteristic Values	Unit
$I_R$	$V_R=V_{RRM}; T_{VJ}=25^{\circ}C$ $V_R=V_{RRM}; T_{VJ}=T_{VJM}$	$\leq 0.3$ $\leq 5$	mA
$V_F$	$I_F=150A; T_{VJ}=25^{\circ}C$	$\leq 1.6$	V
$V_{TO}$	For power-loss calculations only	0.8	V
$r_T$	$T_{VJ}=T_{VJM}$	5	$m\Omega$
$R_{thJC}$	per diode per module	1.1 0.183	K/W
$R_{thJK}$	per diode per module	1.52 0.253	K/W
$d_s$	Creeping distance on surface	10	mm
$d_A$	Creepage distance in air	9.4	mm
$a$	Max. allowable acceleration	50	$m/s^2$

### FEATURES

- \* Package with screw terminals
- \* Isolation voltage 3000 V~
- \* Planar passivated chips
- \* Blocking voltage up to 1800 V
- \* Low forward voltage drop

### APPLICATIONS

- \* Supplies for DC power equipment
- \* Input rectifiers for PWM inverter
- \* Battery DC power supplies
- \* Field supply for DC motors

### ADVANTAGES

- \* Easy to mount with two screws
- \* Space and weight savings
- \* Improved temperature and power cycling