

- Tentative Specification
- Preliminary Specification
- Approval Specification

**MODEL NO.: S231AJ1**

**SUFFIX: LE1**

Revision : <u>A1</u>	
Customer :	
APPROVED BY	SIGNATURE
<u>Name / Title</u> _____	
Note	
_____	
Please return 1 copy for your confirmation with your signature and comments.	

Approved By	Checked By	Prepared By
Chao-Chun Chung	Carlos Lee	John Hsieh

CONTENTS

CONTENTS.....	1
1. GENERAL DESCRIPTION.....	4
1.1 OVERVIEW.....	4
1.2 FEATURES.....	5
1.3 GENERAL SPECIFICATIONS.....	5
1.4 MECHANICAL SPECIFICATIONS.....	6
2. ABSOLUTE MAXIMUM RATINGS.....	6
2.1 ABSOLUTE RATINGS OF ENVIRONMENT.....	6
2.2 PACKAGE STORAGE.....	7
2.3 ELECTRICAL ABSOLUTE RATINGS.....	8
2.3.1 TFT LCD MODULE.....	8
2.3.2 BACKLIGHT CONVERTER UNIT.....	8
3. ELECTRICAL CHARACTERISTICS.....	9
3.1 TFT LCD MODULE.....	9
3.2 BACKLIGHT CONVERTER UNIT.....	10
3.2.1 CONVERTER CHARACTERISTICS.....	11
3.2.2 CONVERTER INTERFACE CHARACTERISTICS.....	12
4. INTERFACE PIN CONNECTION.....	14
4.1 TFT LCD MODULE.....	14
4.2 LVDS INTERFACE.....	16
4.3 COLOR DATA INPUT ASSIGNMENT.....	17
5. INTERFACE TIMING.....	18
5.1 INPUT SIGNAL TIMING SPECIFICATIONS.....	18
5.2 POWER ON/OFF SEQUENCE.....	21
6. OPTICAL CHARACTERISTICS.....	22
6.1 TEST CONDITIONS.....	22
6.2 OPTICAL SPECIFICATIONS.....	23
7. PRECAUTIONS.....	26
7.1 ASSEMBLY AND HANDLING PRECAUTIONS.....	26
7.2 SAFETY PRECAUTIONS.....	27
7.3 SAFETY STANDARDS.....	28

8. DEFINITION OF LABELS..... 29

    8.1 MODULE LABEL.....29

    8.2 CARTON LABEL..... 30

9. PACKAGING..... 30

    9.1 PACKAGING SPECIFICATIONS.....31

    9.2 PACKAGING METHOD..... 31

    9.3 UN-PACKAGING METHOD (type-A).....31

10. MECHANICAL CHARACTERISTIC.....32

**REVISION HISTORY**

Version	Date	Page(New)	Section	Description
1.0	2017/11/28	All		The tentative spec was first issued

## 1. GENERAL DESCRIPTION

### 1.1 OVERVIEW

S231AJ1-LE1 is a 23.1" TFT Liquid Crystal Display PID module with LED Backlight unit and 1ch-LVDS interface. This module supports 1920 x 158 HDTV format and can display 16.7M colors (8-bit). The converter module for backlight is built-in.

### 1.2 FEATURES

- High brightness 500 nits
- High contrast ratio (3000:1)
- Fast response time Gray to gray average (9.5) ms
- High color saturation NTSC 72%
- Full HDTV (158x 1920 pixels) resolution, true HDTV format
- DE (Data Enable) only mode
- LVDS (Low Voltage Differential Signaling) interface
- Optimized response time for 50Hz/60Hz frame rate
- Ultra wide viewing angle : Super MVA technology
- Viewing Angle : 176(H)/176(V) (CR ≥ 20) VA Technology
- RoHs compliance
- T-con input frame rate: 50Hz/60Hz, output frame rate: 50Hz/60Hz

### 1.3 GENERAL SPECIFICATIONS

Item	Specification	Unit	Note
Active Area	585.6(Length) * 48.19(Width)	mm	(1)
Bezel Opening Area	597(Length) * 60(Width)	mm	
Driver Element	a-si TFT active matrix	-	-
Pixel Number	158 x R.G.B. x 1920	pixel	-
Pixel Pitch (Sub Pixel)	0.10167 (H) x 0.305(V)	mm	-
Pixel Arrangement	RGB vertical stripe	-	-
Display Colors	1.07G colors (8-bit+FRC)	color	-
Display Operation Mode	Transmissive mode / Normally black	-	-
Surface Treatment	AGLR coating (Haze <1.0%)	-	(2)
Rotation Function	Unachievable		(3)
Display Orientation	Signal input with "INX"		(3)

Note (1) Please refer to the attached drawings in chapter 9 for more information about the front and back outlines.

Note (2) The spec. of the surface treatment is temporarily for this phase. INX reserves the rights to change this feature.

Note (3)

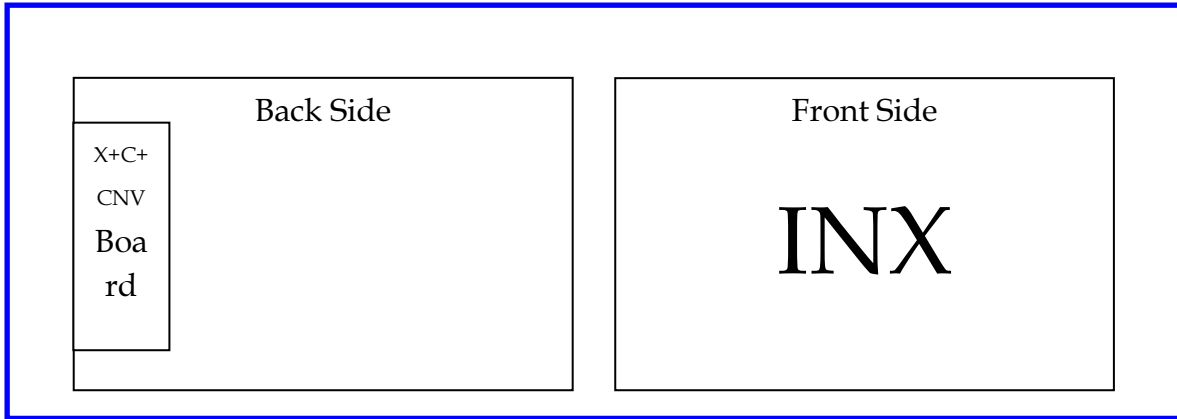

**1.4 MECHANICAL SPECIFICATIONS**

Item		Min.	Typ.	Max.	Unit	Note
Module Size	Horizontal (H)		( 597)		mm	(1)
	Vertical (V)		( 60)		mm	(1)
	Depth (D)		TBD		mm	(2)
	Depth (D)		TBD		mm	(3)
Weight			TBD		Kg	

Note (1) Please refer to the attached drawings for more information of front and back outline dimensions.

Note (2) Module Depth is between bezel to T-CON cover.

Note (3) Module Depth is between bezel to Converter cover

**2. ABSOLUTE MAXIMUM RATINGS**

**2.1 ABSOLUTE RATINGS OF ENVIRONMENT**

Item	Symbol	Value		Unit	Note
		Min.	Max.		
Storage Temperature	TST	-20	+60	°C	(1)
Operating Ambient Temperature	TOP	0	50	°C	(1), (2)
Shock (Non-Operating)	SNOP	-	50	G	(3), (5)
Vibration (Non-Operating)	VNOP	-	1.0	G	(4), (5)

Note (1) Temperature and relative humidity range is shown in the figure below.

- (a) 90 %RH Max.
- (b) Wet-bulb temperature should be 39 °C Max.
- (c) No condensation.

Note (2) Thermal management should be considered in final product design to prevent the surface temperature of display area from being over 65 °C. The range of operating temperature may degrade in case of improper thermal management in final product design.

Note (3) 11 ms, half sine wave, 1 time for ± X, ± Y, ± Z.

Note (4) 10 ~ 200 Hz, 30 min, 1 time each X, Y, Z.

Note (5) At testing Vibration and Shock, the fixture in holding the module has to be hard and rigid enough so that the module would not be twisted or bent by the fixture.

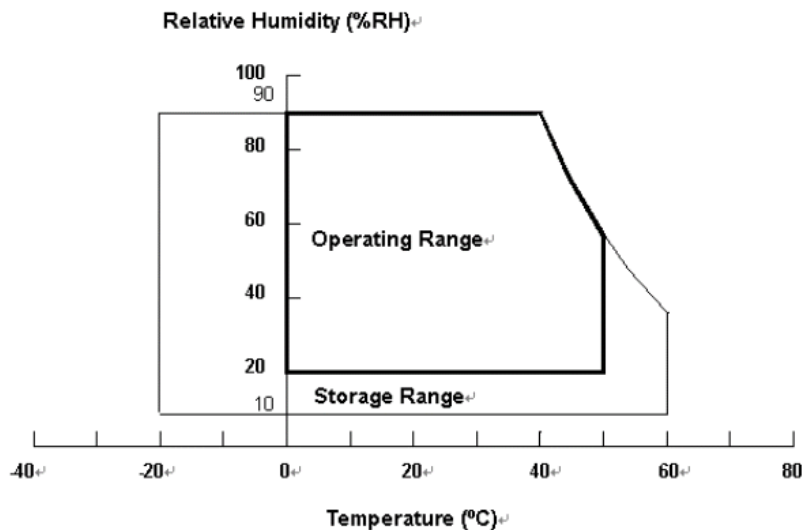

## 2.2 PACKAGE STORAGE

When storing modules as spares for a long time, the following precaution is necessary.

- (a) Do not leave the module in high temperature, and high humidity for a long time, It is highly recommended to store the module with temperature from 0 to 35 °C at normal humidity without condensation.
- (b) The module shall be stored in dark place. Do not store the TFT-LCD module in direct sunlight or fluorescent light.

## 2.3 ELECTRICAL ABSOLUTE RATINGS

### 2.3.1 TFT LCD MODULE

Item	Symbol	Value		Unit	Note
		Min.	Max.		
Power Supply Voltage	VCC	-0.3	13.5	V	(1)
Logic Input Voltage	VIN	-0.3	3.6	V	
Component thermal	-	-	100		(2)

Note (1) Permanent damage to the device may occur if maximum values are exceeded. Function operation should be restricted to the conditions described under Normal Operating Conditions

(2) The surface temperature of Source Driver and component on PCB should be controlled under 100°C operating over thermal spec can cause the damage or decrease of lifetime.

### 2.3.2 BACKLIGHT CONVERTER UNIT

Item	Symbol	Value		Unit	Note
		Min.	Max.		
Light Bar Voltage	VW	—	60	VRMS	
Converter Input Voltage	VBL	0	30	V	(1)
Control Signal Level	—	-0.3	6	V	(1), (3)

Note (1) Permanent damage to the device may occur if maximum values are exceeded. Functional operation should be restricted to the conditions described under normal operating conditions.

Note (2) No moisture condensation or freezing.



3. ELECTRICAL CHARACTERISTICS

3.1 TFT LCD MODULE

(Ta = 25 ± 2 °C)

Parameter		Symbol	Value			Unit	Note
			Min.	Typ.	Max.		
Power Supply Voltage		V <sub>CC</sub>	10.8	12	13.2	V	(1)
Rush Current		I <sub>RUSH</sub>	—	—	(TBD)	A	(2)
Power Consumption	White Pattern	P <sub>T</sub>	—	(TBD)	(TBD)	W	(3)
	Black Pattern	P <sub>T</sub>	—	(TBD)	(TBD)	W	
	Heavy Loading pattern	P <sub>T</sub>	—	(5)	(5.6)	W	
Power Supply Current	White Pattern	—	—	(TBD)	(TBD)	A	
	Black Pattern	—	—	(TBD)	(TBD)	A	
	Heavy Loading pattern	—	—	(0.48)	(0.52)	A	
LVDS interface	Differential Input High Threshold Voltage	V <sub>TH</sub>	—	—	+100	mV	(4)
	Differential Input Low Threshold Voltage	V <sub>TL</sub>	-100	—	—	mV	
	Common Input Voltage	V <sub>CM</sub>	1.0	1.2	1.4	V	
	Differential input voltage (single-end)	V <sub>ID</sub>	100	—	600	mV	
	Terminating Resistor	R <sub>T</sub>	—	100	—	ohm	
CMIS interface	Input High Threshold Voltage	V <sub>IH</sub>	2.7	—	3.3	V	
	Input Low Threshold Voltage	V <sub>IL</sub>	0	—	0.7	V	

Note (1) The module should be always operated within the above ranges. The ripple voltage should be controlled under 10% of  $V_{cc}$  (Typ.)

Note (2) Measurement Conditions :

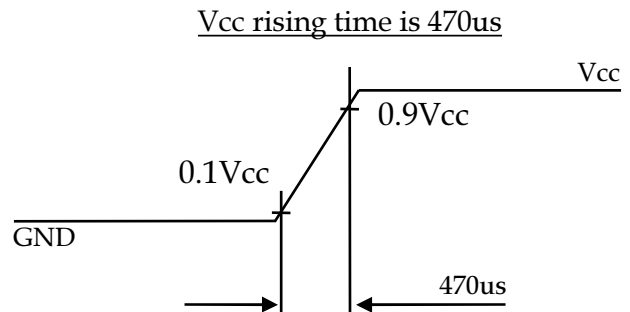
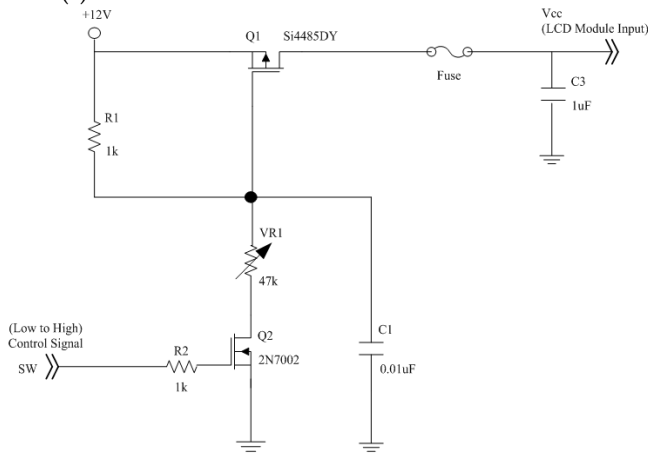

Note (3) The specified power supply current is under the conditions at  $V_{cc} = 12\text{ V}$ ,  $T_a = 25 \pm 2\text{ }^\circ\text{C}$ ,  $f_v = 60\text{ Hz}$ , whereas a power dissipation check pattern below is displayed.

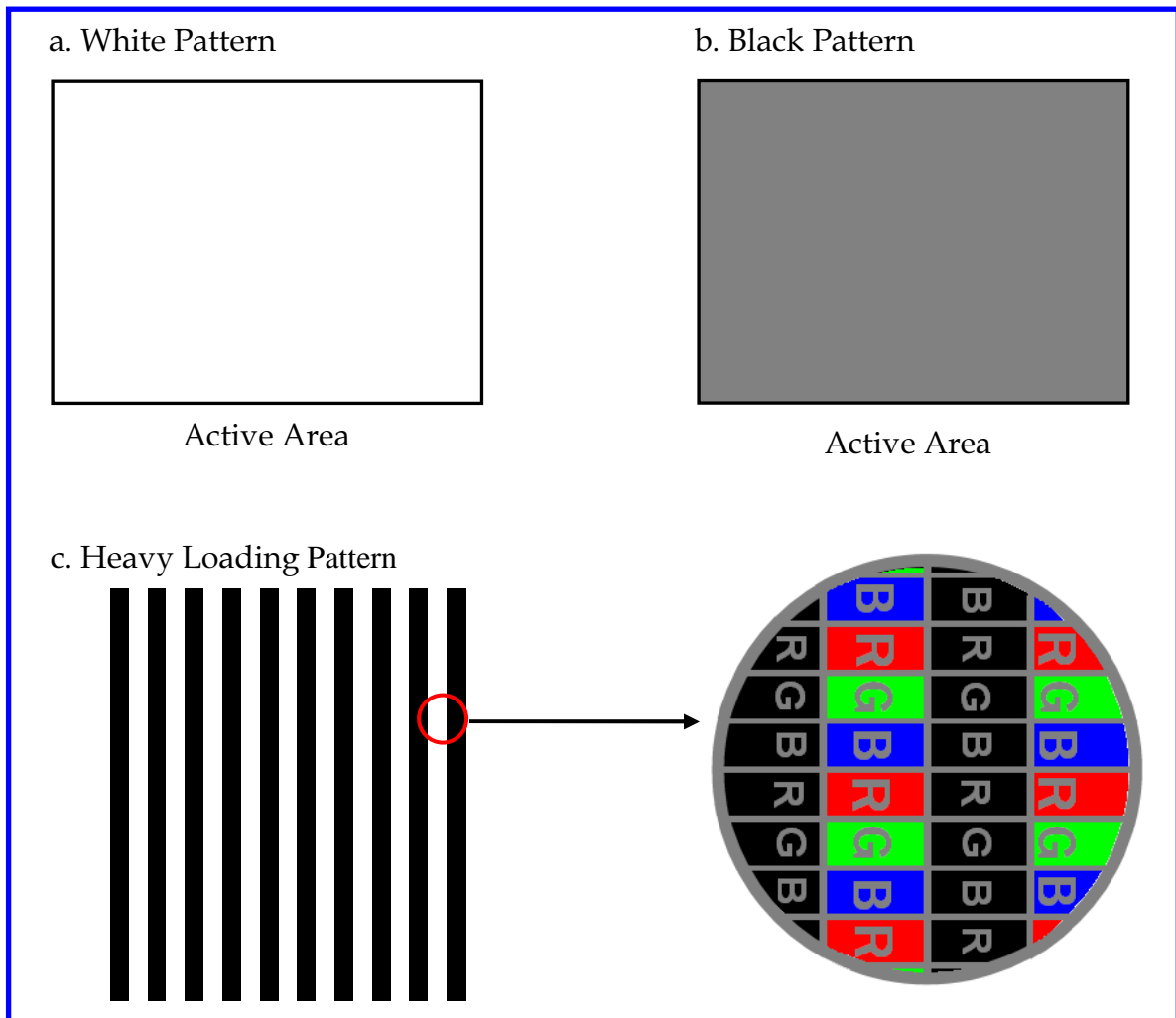

Note (4) The LVDS input characteristics is shown as below : The position of measurement is TCON LVDS input pin. The differential voltage must be higher than  $V_{TH}$  and lower than  $V_{TL}$  to ensure that the receiver indicates a valid logic state at its output.

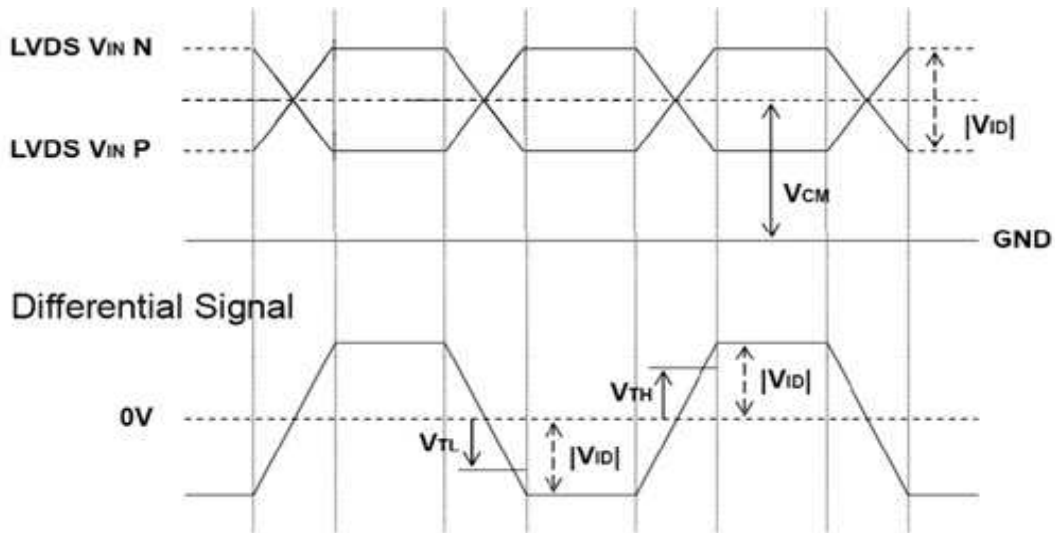

### 3.2 BACKLIGHT CONVERTER UNIT

#### 3.2.1 CONVERTER CHARACTERISTICS

Parameter	Symbol	Value			Unit	Note
		Min.	Typ.	Max.		
Power Consumption	$P_{BL}$	-	2.91	3.03	W	(1), (2)
Converter Input Voltage	VBL	11.4	12.0	12.6	VDC	
Converter Input Current	$I_{BL}$	-	2.43	0.25	A	Non Dimming
Input Inrush Current	$I_R$	-	-	0.8	Apeak	$V_{BL}=11.4V_7$ (3)
Dimming Frequency	FB	150	160	170	Hz	
Dimming Duty Ratio	DDR	5	-	100	%	(4)
Life Time	-	30,000	-	-	Hrs	(5)

Note (1) The power supply capacity should be higher than the total converter power consumption PBL. Since the pulse width modulation (PWM) mode was applied for backlight dimming, the driving current changed as PWM duty on and off. The transient response of power supply should be considered for the changing loading when converter dimming.

Note (2) The measurement condition of Max. value is based on 58" backlight unit under input voltage 24V.

Note (3) For input inrush current measure, the VBL rising time from 10% to 90% is about 20ms.

Note (4) EPWM signal have to input available duty range. 5% minimum duty ratio is only valid for electrical operation.

Note (5) The lifetime is defined as the time which luminance of the LED decays to 50% compared to the initial value,  
Operating condition: Continuous operating at  $T_a = 25 \pm 2^\circ\text{C}$

3.2.2 CONVERTER INTERFACE CHARACTERISTICS

Parameter		Symbol	Test Conditio	Value			Unit	Note	
				Min.	Typ.	Max.			
On/Off Control Voltage	ON	VBLON	—	2.0	—	5.0	V		
	OFF		—	0	—	0.8	V		
External PWM Control Voltage	HI	VEPWM	—	2.0	—	5.0	V	Duty on	(5)
	LO		—	0	—	0.8	V	Duty off	
Error Signal		ERR	—	—	—	—	—	Abnormal: Open	
VBL Rising Time		Tr1	—	20	—	—	ms	10%-90% V <sub>BL</sub>	
Control Signal Rising Time		Tr	—	—	—	100	ms		
Control Signal Falling Time		Tf	—	—	—	100	ms		
PWM Signal Rising Time		TPWM	—	—	—	50	us		
PWM Signal Falling Time		TPWM	—	—	—	50	us		
Input Impedance		Rin	—	1	—	—	MΩ		
PWM Delay Time		TPWM	—	100	—	—	ms		
BLON Delay Time		T <sub>on</sub>	—	300	—	—	ms		
		T <sub>on1</sub>	—	300	—	—	ms		
BLON Off Time		Toff	—	300	—	—	ms		

Note (1) The Dimming signal should be valid before backlight turns on by BLON signal. It is inhibited to change the external PWM signal during backlight turn on period.

Note (2) The power sequence and control signal timing are shown in the Fig.1. For a certain reason, the converter has a possibility to be damaged with wrong power sequence and control signal timing.

Note (3) While system is turned ON or OFF, the power sequences must follow as below descriptions:

Turn ON sequence: VBL → PWM signal → BLON

Turn OFF sequence: BLOFF → PWM signal → VBL

Note (4) When converter protective function is triggered, ERR will output open collector status. (Fig.2)

Note (5) The EPWM interface that inserts a pull up resistor to 5V in Max Duty (100%), please refers to Fig.3.

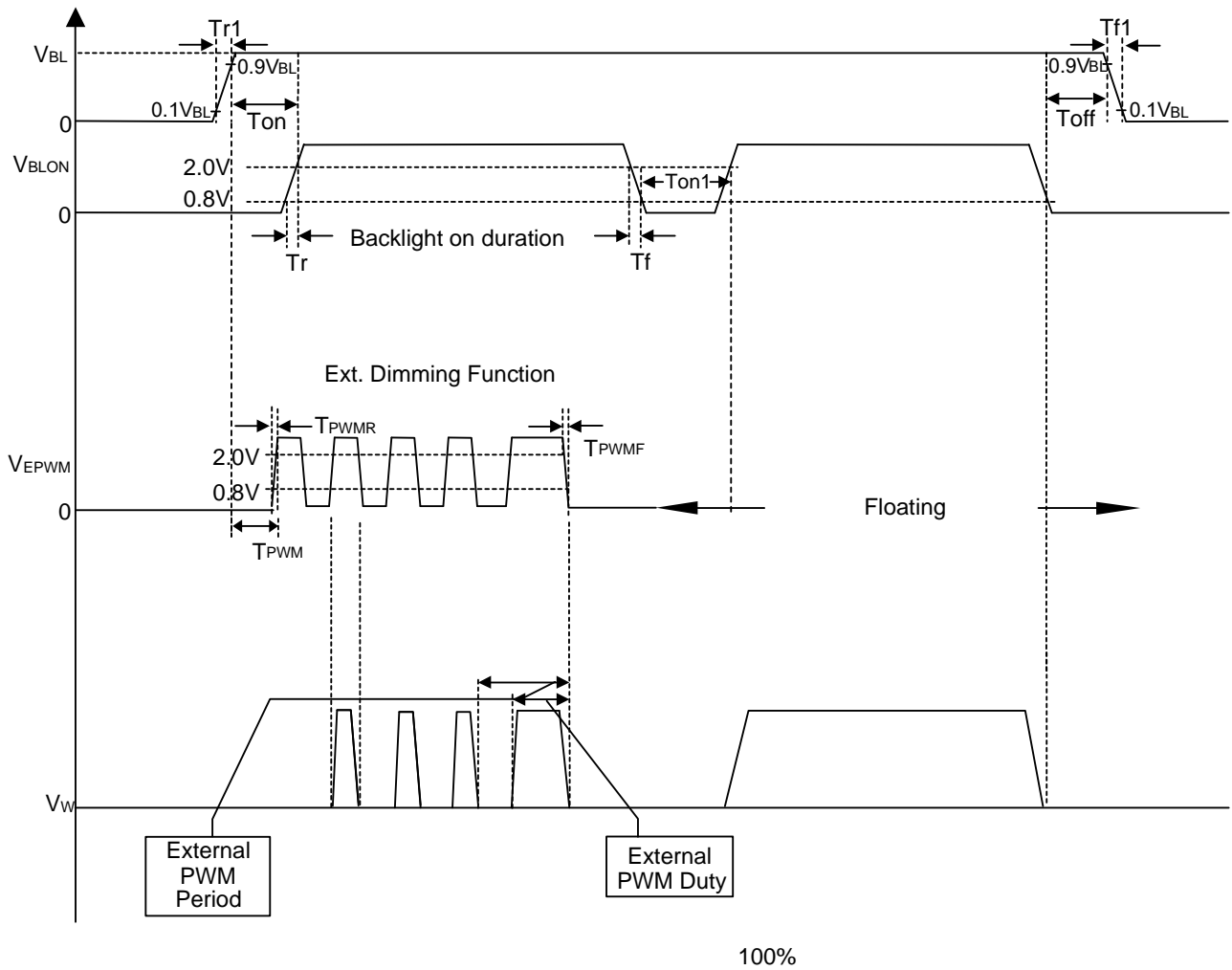

Fig. 1

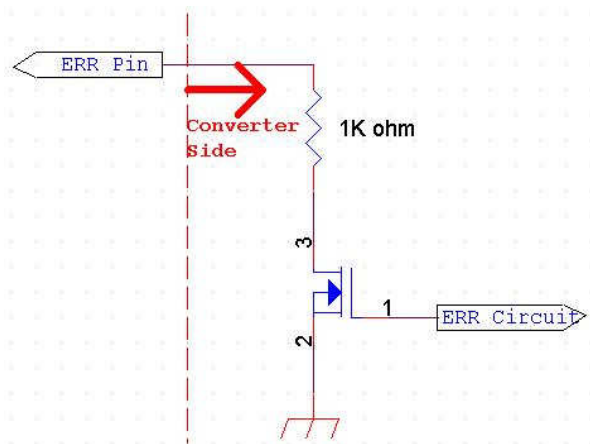

Fig. 2

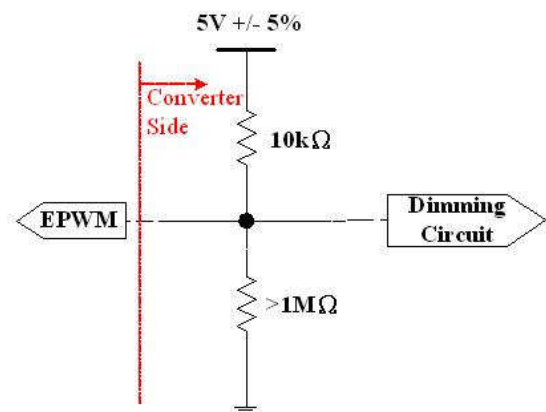

Fig. 3

#### 4. INTERFACE PIN CONNECTION

##### 4.1 TFT LCD MODULE

CNF1 Connector : 7003J30-000000-G2-(STARCONN)

Connector Pin Assignment

Pin	Name	Description	Remark
1	Vcc	+12V power supply	
2	Vcc	+12V power supply	
3	Vcc	+12V power supply	
4	Vcc	+12V power supply	
5	Vcc	+12V power supply	
6	EPWM Control	External dimming function for backlight brightness adjustment	(5)
7	GND	Ground	
8	GND	Ground	
9	SELLVDS	LVDS data format selection. GND is JEDIA for INX.	(3)(4)
10	LCD_BL	Backlight Enable Signal	(5)
11	GND	Ground	
12	NC	No connection	(2)
13	RX3+	Positive LVDS differential data input. Channel 3	
14	NC	No connection	(2)
15	RX3-	Negative LVDS differential data input. Channel 3	
16	NC	No connection	(2)
17	GND	Ground	
18	GND	Ground	
19	RXCLK+	Positive LVDS differential clock input.	
20	RX0-	Negative LVDS differential data input. Channel 0	
21	RXCLK-	Negative LVDS differential clock input.	
22	RX0+	Positive LVDS differential data input. Channel 0	
23	GND	Ground	
24	GND	Ground	
25	RX2+	Positive LVDS differential data input. Channel 2	
26	RX1-	Negative LVDS differential data input. Channel 1	
27	RX2-	Negative LVDS differential data input. Channel 2	
28	RX1+	Positive LVDS differential data input. Channel 1	
29	GND	Ground	
30	GND	Ground	

Note (1) LVDS connector pin order is defined as below.

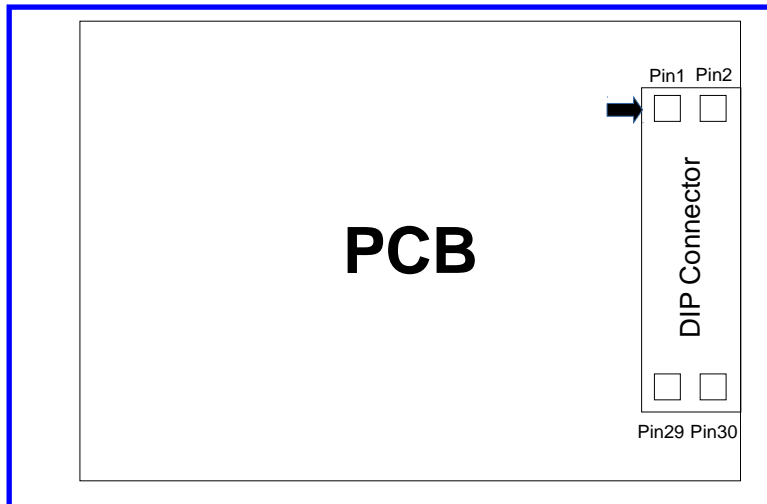

Note (2) Reserved for internal use. Please leave it open.

Note (3)

SELLVDS	Mode
L	JEIDA
H	VESA

L : Connect to GND, H : Connect to Open or +3.3V

Note (4) Interface optional pin has internal scheme as following diagram. Customer should keep the interface voltage level requirement which including panel board loading as below.

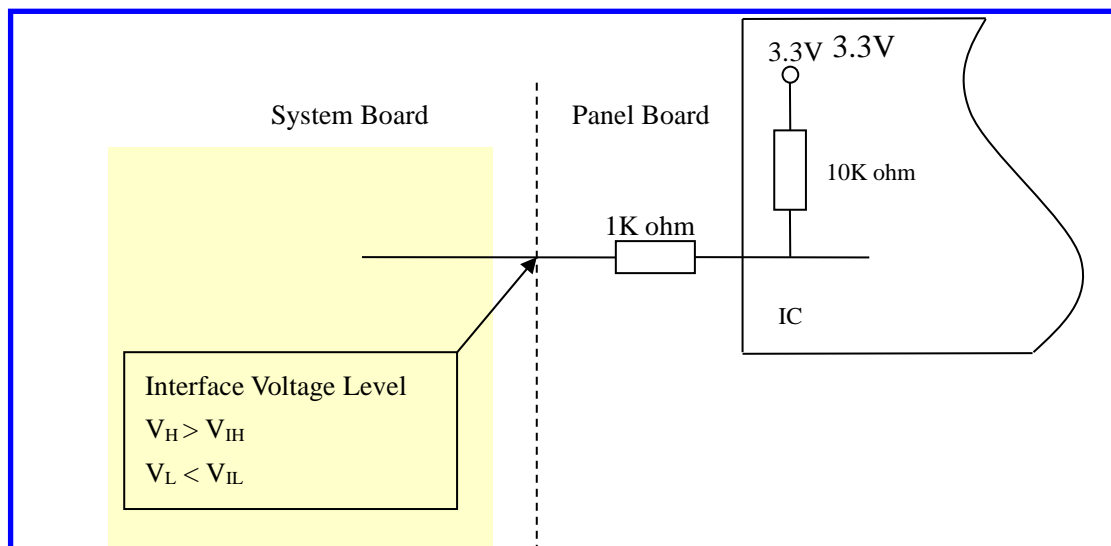

Note (5) Please refer converter page.

4.2 LVDS INTERFACE

VESA Format : SELLVDS = H or Open

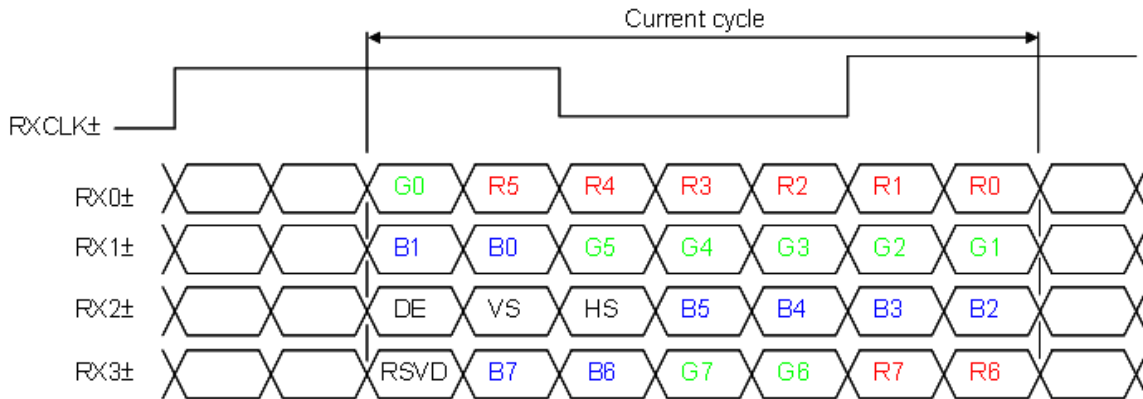

JEIDA Format : SELLVDS = L

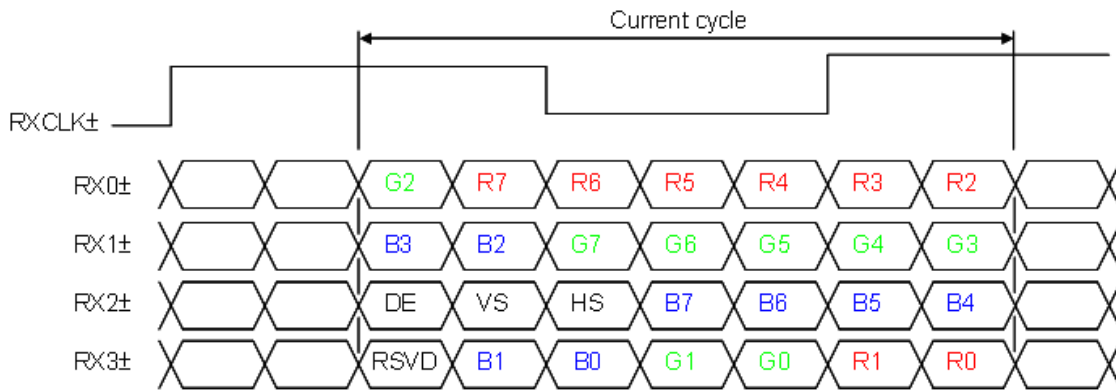

R0~R7 : Pixel R Data (7; MSB, 0; LSB)

G0~G7 : Pixel G Data (7; MSB, 0; LSB)

B0~B7 : Pixel B Data (7; MSB, 0; LSB)

DE : Data enable signal

DCLK : Data clock signal

Notes: (1) RSVD (reserved) pins on the transmitter shall be "H" or "L".



**4.3 COLOR DATA INPUT ASSIGNMENT**

The brightness of each primary color (red, green and blue) is based on the 8-bit gray scale data input for the color. The higher the binary input, the brighter the color. The table below provides the assignment of the color versus data input.

Color		Data Signal																							
		Red								Green						Blue									
		R7	R6	R5	R4	R3	R2	R1	R0	G7	G6	G5	G4	G3	G2	G1	G0	B7	B6	B5	B4	B3	B2	B1	B0
Basic Colors	Black	0	0	0	0	0	0	0	0	0	0	0	0	0	0	0	0	0	0	0	0	0	0	0	0
	Red	1	1	1	1	1	1	1	1	0	0	0	0	0	0	0	0	0	0	0	0	0	0	0	0
	Green	0	0	0	0	0	0	0	0	1	1	1	1	1	1	1	1	0	0	0	0	0	0	0	0
	Blue	0	0	0	0	0	0	0	0	0	0	0	0	0	0	0	0	1	1	1	1	1	1	1	1
	Cyan	0	0	0	0	0	0	0	0	1	1	1	1	1	1	1	1	1	1	1	1	1	1	1	1
	Magenta	1	1	1	1	1	1	1	1	0	0	0	0	0	0	0	0	1	1	1	1	1	1	1	1
	Yellow	1	1	1	1	1	1	1	1	1	1	1	1	1	1	1	1	0	0	0	0	0	0	0	0
	White	1	1	1	1	1	1	1	1	1	1	1	1	1	1	1	1	1	1	1	1	1	1	1	1
Gray Scale Of Red	Red (0) / Dark	0	0	0	0	0	0	0	0	0	0	0	0	0	0	0	0	0	0	0	0	0	0	0	
	Red (1)	0	0	0	0	0	0	0	1	0	0	0	0	0	0	0	0	0	0	0	0	0	0	0	
	Red (2)	0	0	0	0	0	0	1	0	0	0	0	0	0	0	0	0	0	0	0	0	0	0	0	
	:	:	:	:	:	:	:	:	:	:	:	:	:	:	:	:	:	:	:	:	:	:	:	:	
	:	:	:	:	:	:	:	:	:	:	:	:	:	:	:	:	:	:	:	:	:	:	:	:	
	Red (253)	1	1	1	1	1	1	0	1	0	0	0	0	0	0	0	0	0	0	0	0	0	0	0	
	Red (254)	1	1	1	1	1	1	1	0	0	0	0	0	0	0	0	0	0	0	0	0	0	0	0	
	Red (255)	1	1	1	1	1	1	1	1	0	0	0	0	0	0	0	0	0	0	0	0	0	0	0	
Gray Scale Of Green	Green (0) / Dark	0	0	0	0	0	0	0	0	0	0	0	0	0	0	0	0	0	0	0	0	0	0	0	
	Green (1)	0	0	0	0	0	0	0	0	0	0	0	0	0	0	0	1	0	0	0	0	0	0	0	
	Green (2)	0	0	0	0	0	0	0	0	0	0	0	0	0	0	1	0	0	0	0	0	0	0	0	
	:	:	:	:	:	:	:	:	:	:	:	:	:	:	:	:	:	:	:	:	:	:	:	:	
	:	:	:	:	:	:	:	:	:	:	:	:	:	:	:	:	:	:	:	:	:	:	:	:	
	Green (253)	0	0	0	0	0	0	0	0	1	1	1	1	1	1	0	1	0	0	0	0	0	0	0	
	Green (254)	0	0	0	0	0	0	0	0	1	1	1	1	1	1	1	0	0	0	0	0	0	0	0	
	Green (255)	0	0	0	0	0	0	0	0	1	1	1	1	1	1	1	1	0	0	0	0	0	0	0	
Gray Scale Of Blue	Blue (0) / Dark	0	0	0	0	0	0	0	0	0	0	0	0	0	0	0	0	0	0	0	0	0	0	0	
	Blue (1)	0	0	0	0	0	0	0	0	0	0	0	0	0	0	0	0	0	0	0	0	0	0	1	
	Blue (2)	0	0	0	0	0	0	0	0	0	0	0	0	0	0	0	0	0	0	0	0	0	1	0	
	:	:	:	:	:	:	:	:	:	:	:	:	:	:	:	:	:	:	:	:	:	:	:	:	
	:	:	:	:	:	:	:	:	:	:	:	:	:	:	:	:	:	:	:	:	:	:	:	:	
	Blue (253)	0	0	0	0	0	0	0	0	0	0	0	0	0	0	0	1	1	1	1	1	1	0	1	
	Blue (254)	0	0	0	0	0	0	0	0	0	0	0	0	0	0	0	1	1	1	1	1	1	1	0	
	Blue (255)	0	0	0	0	0	0	0	0	0	0	0	0	0	0	0	1	1	1	1	1	1	1	1	

Note (1) 0: Low Level Voltage, 1: High Level Voltage

## 5. INTERFACE TIMING

### 5.1 INPUT SIGNAL TIMING SPECIFICATIONS

The input signal timing specifications are shown as the following table and timing diagram.

Signal	Item	Symbol	Min.	Typ.	Max.	Unit	Note
LVDS Receiver Clock	Frequency	$F_{clk_{in}}$ (=1/TC)	60	74.25	80	MHz	
	Input cycle to cycle jitter	$T_{rcl}$	—	—	200	ps	(3)
	Spread spectrum modulation range	$F_{clk_{in\_mod}}$	$F_{clk_{in}}-2\%$	—	$F_{clk_{in}}+2\%$	MHz	(4)
	Spread spectrum modulation frequency	$F_{SSM}$	—	—	200	KHz	
LVDS Receiver Data	Receiver Skew Margin	$T_{RSKM}$	-400	—	400	ps	(5)
Vertical Active Display Term	Frame Rate	$F_{r5}$	47	50	53	Hz	
		$F_{r6}$	57	60	63	Hz	
	Total	$T_v$	(TBD)	2000	(TBD)	Th	$T_v=T_{vd}+T_{vb}$
	Display	$T_{vd}$	1920	1920	1920	Th	
	Blank	$T_{vb}$	(TBD)	80	(TBD)	Th	
Horizontal Active Display Term	Total	$T_h$	(TBD)	600	(TBD)	$T_c$	$T_h=T_{hd}+T_{hb}$
	Display	$T_{hd}$	256	256	256	$T_c$	
	Blank	$T_{hb}$	(TBD)	344	(TBD)	$T_c$	

Note (1) Please make sure the range of frame rate has follow the below equation :

$$F_{clk_{in}}(\max) \geq Fr6 \times T_v \times T_h$$

$$Fr5 \times T_v \times T_h \geq F_{clk_{in}}(\min)$$

Note (2) This module is operated in DE only mode and please follow the input signal timing diagram as below :

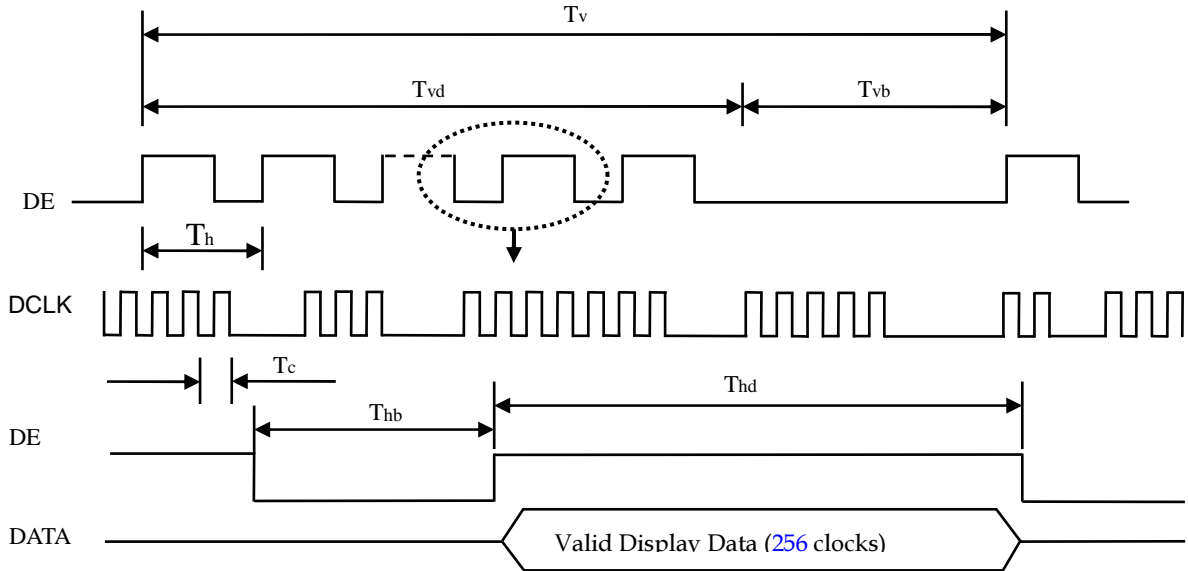

Note (3) The input clock cycle-to-cycle jitter is defined as below figures.  $Trcl = |T_1 - T|$

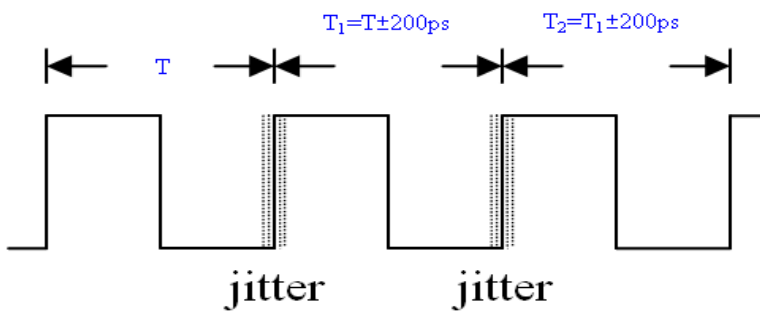

Note (4) The SSCG (Spread spectrum clock generator) is defined as below figures.

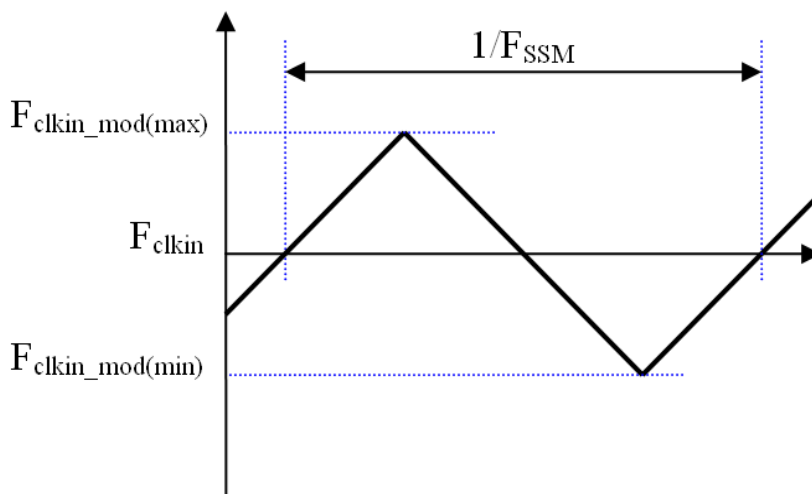

Note (5) The LVDS timing diagram and the receiver skew margin is defined and shown in following figure.

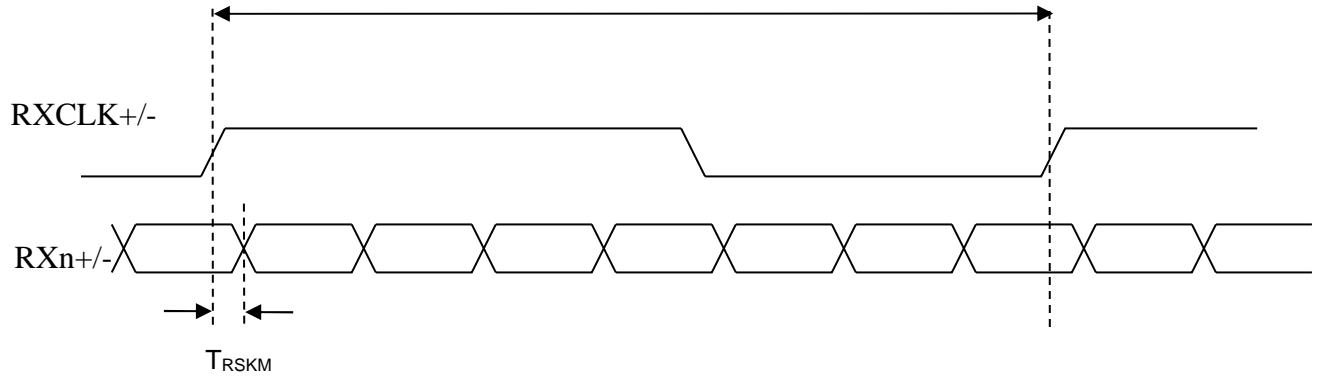

5.2 POWER ON/OFF SEQUENCE

(Ta = 25 ± 2 °C)

To prevent a latch-up or DC operation of LCD module, the power on/off sequence should be as the diagram below.

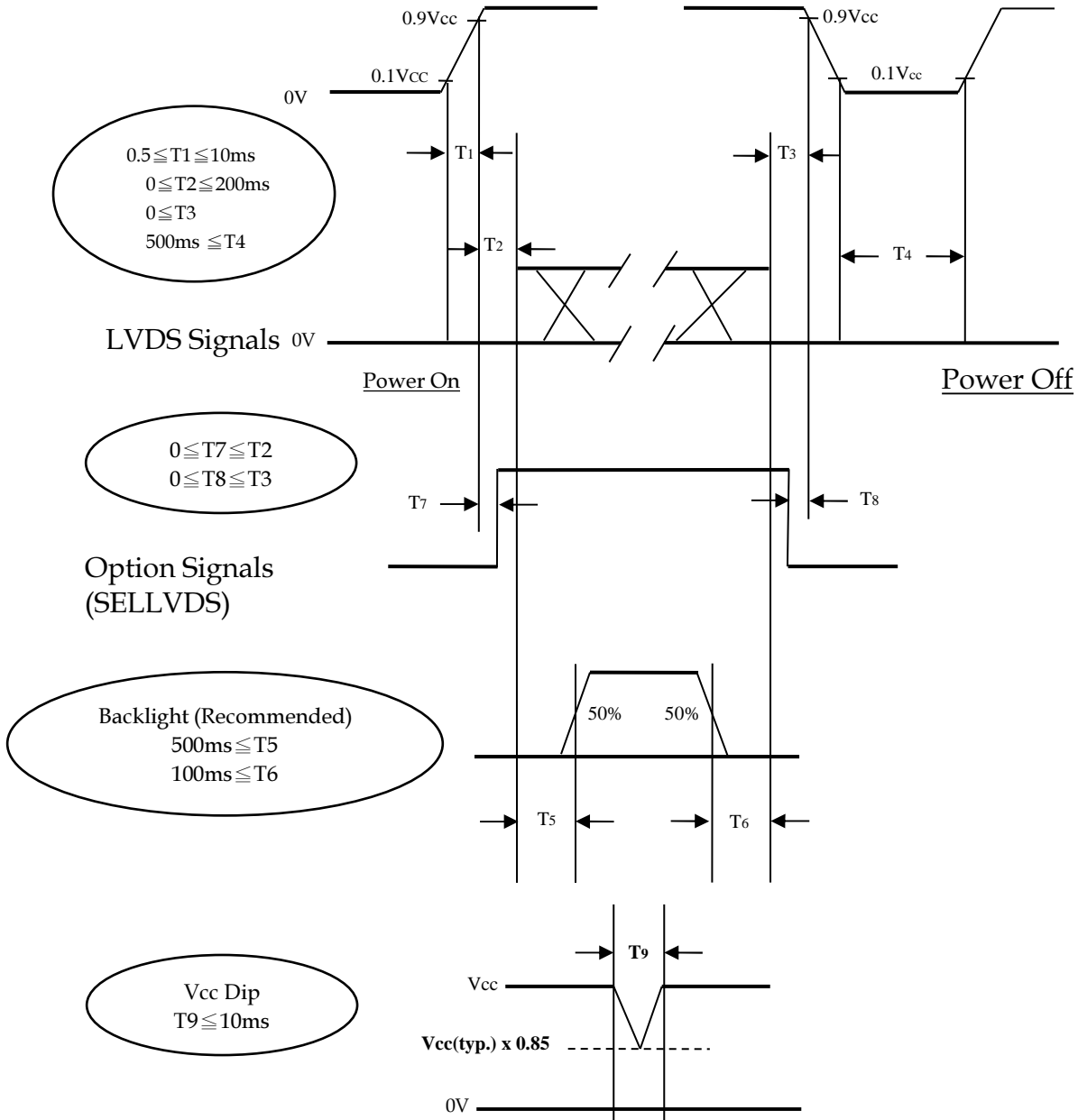

Note (1) The supply voltage of the external system for the module input should follow the definition of Vcc.

Note (2) Apply the LED voltage within the LCD operation range. When the backlight turns on before the LCD operation or the LCD turns off before the backlight turns off, the display may momentarily become abnormal screen.

Note (3) In case of VCC is in off level, please keep the level of input signals on the low or high impedance.

Note (4) T4 should be measured after the module has been fully discharged between power off and on period.

Note (5) Interface signal shall not be kept at high impedance when the power is on.

Note (6) Vcc must decay smoothly when power-off.

6. OPTICAL CHARACTERISTICS

6.1 TEST CONDITIONS

Item	Symbol	Value	Unit
Ambient Temperature	Ta	25±2	°C
Ambient Humidity	Ha	50±10	%RH
Supply Voltage	VCC	12±1.2	V
Input Signal	According to typical value in "3. ELECTRICAL CHARACTERISTICS"		
Vertical Frame Rate	Fr	60	Hz

The LCD module should be stabilized at given temperature for 1 hour to avoid abrupt temperature change during measuring in a windless room.

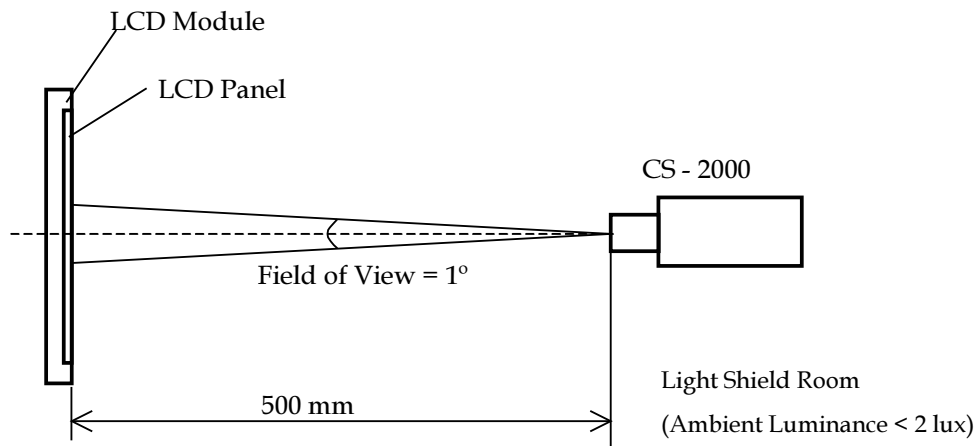

## 6.2 OPTICAL SPECIFICATIONS

The relative measurement methods of optical characteristics are shown in 7.2. The following items should be measured under the test conditions described in 7.1 and stable environment shown in 7.1.

Item		Symbol	Condition	Min.	Typ.	Max.	Unit	Note				
Contrast Ratio		CR	$\theta_x=0^\circ, \theta_y=0^\circ$ Viewing angle at normal direction	(2100)	(3000)	-	-	(2)				
Response Time		Gray to gray			9.5	19	ms	(3)				
Center Luminance of White		$L_C$		(420)	(500)	-	cd/m <sup>2</sup>	(4)				
White Variation		$\delta W$				1.3	-	(6)				
Cross Talk		CT		-		4	%	(5)				
Color Chromaticity	Red	Rx		Viewing angle at normal direction	Typ.- 0.03	(0.635)	Typ.+ 0.03	-				
		Ry				(0.332)		-				
	Green	Gx	(0.305)			-						
		Gy	(0.620)			-						
	Blue	Bx	(0.153)			-						
		By	(0.057)			-						
	White	Wx	0.280			-						
		Wy	0.290			-						
	Correlated color temperature					-		10000		-	K	
	Color Gamut		C.G.			-		72		-	%	NTSC
Viewing Angle	Horizontal	$\theta_{x+}$	CR $\geq$ 20	80	88	-	Deg.	(1)				
		$\theta_{x-}$		80	88	-						
	Vertical	$\theta_{y+}$		80	88	-						
		$\theta_{y-}$		80	88	-						

Note (1) Definition of Viewing Angle ( $\theta_x, \theta_y$ ) :

Viewing angles are measured by Autronic Conoscope Cono-80 (or Eldim EZ-Contrast 160R).

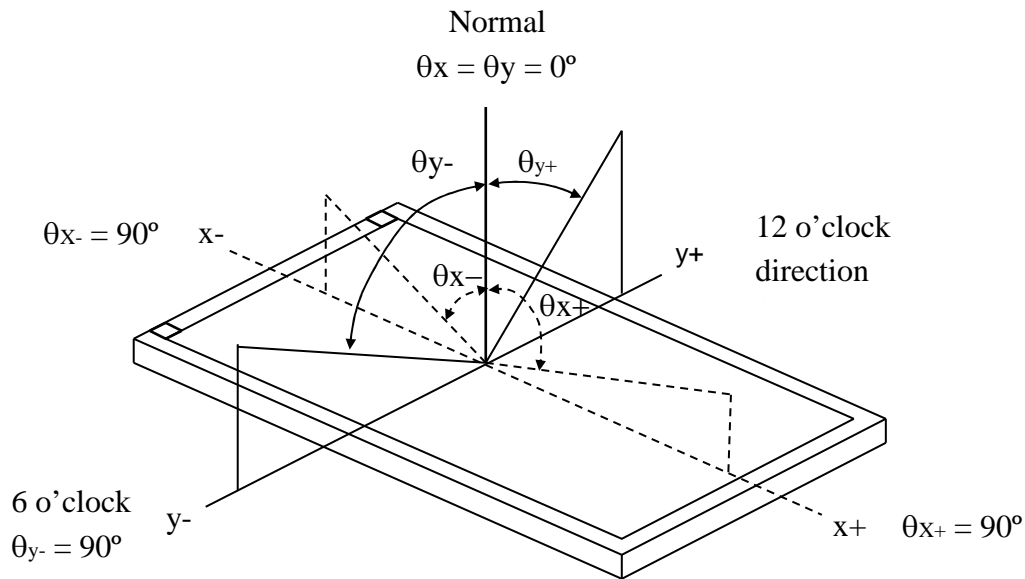

Note (2) Definition of Contrast Ratio (CR) :

The contrast ratio can be calculated by the following expression.

$$\text{Contrast Ratio (CR)} = \frac{\text{Surface Luminance of L255}}{\text{Surface Luminance of L0}}$$

L255: Luminance of gray level 255

L 0: Luminance of gray level 0

CR = CR (5), where CR (X) is corresponding to the Contrast Ratio of the point X at the figure in Note (6).

Note (3) Definition of Gray-to-Gray Switching Time :

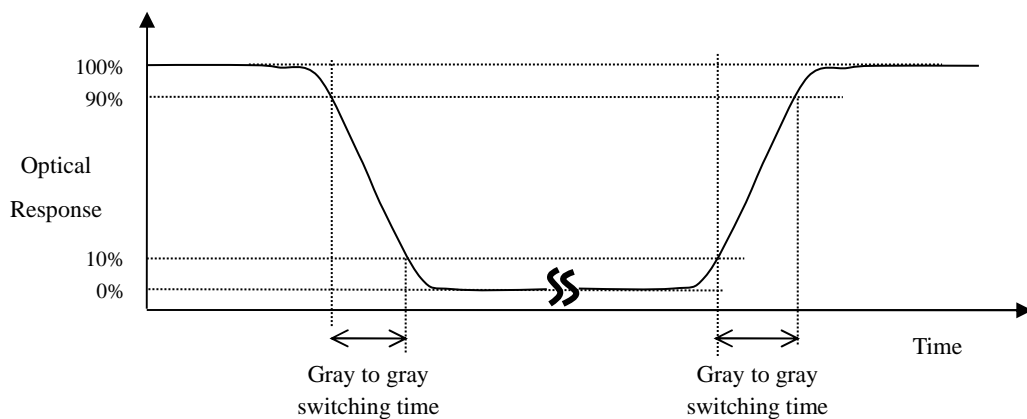

The driving signal means the signal of gray level 0, 31, 63, 95, 127, 159, 191, 223 and 255.

Gray to gray average time means the average switching time of gray level 0, 31, 63, 95, 127, 159, 191, 223 and 255 to each other.



Note (4) Definition of Luminance of White ( $L_C, L_{AVE}$ ) :

Measure the luminance of gray level 255 at center point and 5 points

$L_C = L(5)$ , where  $L(X)$  is corresponding to the luminance of the point  $X$  at the figure in Note (6).

Note (5) Definition of Cross Talk (CT) :

$$CT = | Y_B - Y_A | / Y_A \times 100 (\%)$$

Where:

$Y_A$  = Luminance of measured location without gray level 255 pattern (cd/m<sup>2</sup>)

$Y_B$  = Luminance of measured location with gray level 255 pattern (cd/m<sup>2</sup>)

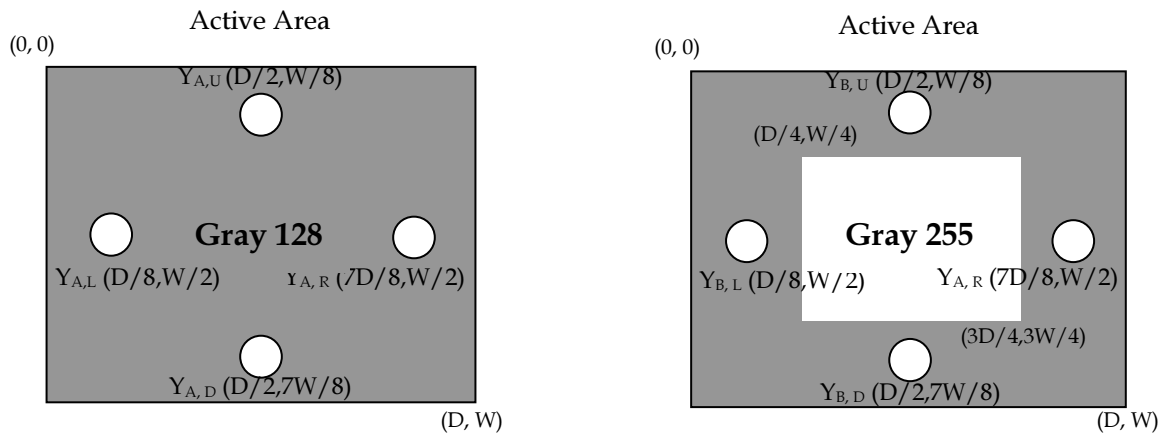

Note (6) Definition of White Variation ( $\delta W$ ) :

Measure the luminance of gray level 255 at 5 points

$$\delta W = \frac{\text{Maximum} [L(1), L(2), L(3), L(4), L(5)]}{\text{Minimum} [L(1), L(2), L(3), L(4), L(5)]}$$

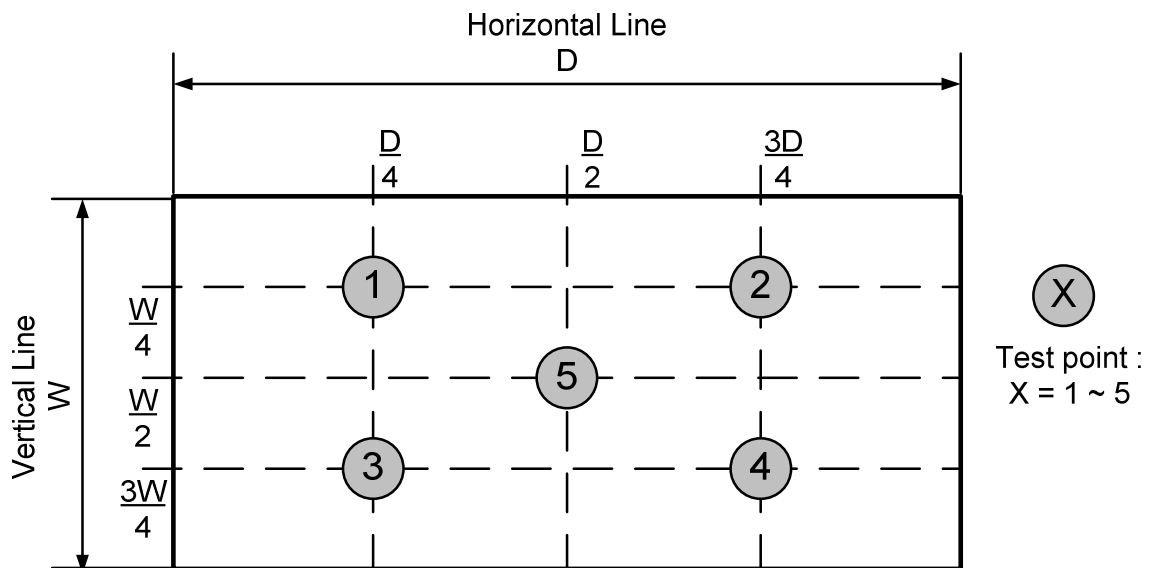

## 7. PRECAUTIONS

### 7.1 ASSEMBLY AND HANDLING PRECAUTIONS

- [1] Do not apply rough force such as bending or twisting to the module during assembly.
- [2] Do not apply pressure or impulse to the module to prevent the damage of LCD panel and Backlight.
- [3] Bezel of Set can not press or touch the panel surface. It will make light leakage or scrape.
- [4] It should be attached to the system firmly using all mounting holes.
- [5] It is recommended to assemble or to install a module into the user's system in clean working areas. The dust and oil may cause electrical short or worsen the polarizer, do not press or scratch the surface harder than a HB pencil lead.
- [6] Use finger-stalls with soft gloves in order to keep display clean during the incoming inspection and assembly process.
- [7] Protection film for polarizer on the module should be slowly peeled off just before use so that the electrostatic charge can be minimized.
- [8] Do not disassemble the module.
- [9] Always follow the correct power-on sequence when the LCD module is turned on. This can prevent the damage and latch-up of the CMOS LSI chips.
- [10] Do not plug in or pull out the I/F connector while the module is in operation, pins of I/F connector should not be touched directly with bare hands. Do not adjust the variable resistor located on the module.
- [11] Moisture can easily penetrate into LCD module and may cause the damage during operation.
- [12] When storing modules as spares for a long time, the following precaution is necessary.
  - [12.1] Do not leave the module in high temperature, and high humidity for a long time. It is highly recommended to store the module with temperature from 0 to 35°C at normal humidity (under 70%) without condensation.
  - [12.2] The module shall be stored in dark place. Do not store the TFT-LCD module in direct sunlight or fluorescent light.
- [13] When ambient temperature is lower than 10°C, the display quality might be reduced. For example, the response time will become slow, and the starting voltage of LED will be higher than that of room temperature.

## 7.2 SAFETY PRECAUTIONS

To optimize PID module's lifetime and functions, operating conditions should be followed as below

[1] Normal operating condition

[1.1] Temperature :  $20\pm 15^{\circ}\text{C}$

[1.2] Humidity :  $55\pm 20\%$

[1.3] Well-ventilated place is suggested to set up PID module and system.

[1.4] Display pattern : regular switched patterns or moving pictures.

[2] Operation usage to protect against image sticking due to long-term static display.

[2.1] Suitable operating time : under 24 hours a day.

(\* The moving picture can be allowed for 24 hours a day)

[2.2] Liquid Crystal refresh time is required. Cycling display between 5 minutes' information (static) display and 10 seconds' moving image.

[2.3] Periodical display contents should be changed from static image to moving picture.

[2.3.1] Different background and image colors changed respectively, and changed colors periodically.

[2.3.2] Background and image with large different luminance displayed at the same time should be avoided.

[2.3.3] Periodical power-off the system for a while or screen saver is needed after long-term static display.

[2.3.4] Moving picture or black pattern is strongly recommended for screen saver.

[3] The startup voltage of a Backlight may cause an electrical shock while assembling with the converter. Do not disassemble the module or insert anything into the Backlight unit.

[4] Do not connect or disconnect the module in the "Power On" condition.

[5] Do not exceed the absolute maximum rating value. (supply voltage variation, input voltage variation, variation in part contents and environmental temperature...) Otherwise the module may be damaged.

[6] If the liquid crystal material leaks from the panel, it should be kept away from the eyes or mouth. In case of contact with hands, skin or clothes, it has to be washed away thoroughly with soap.

[7] Module should be turned clockwise (regular front view perspective) when used in portrait mode.

[8] Ultra-violet ray filter is necessary for outdoor operation.

[9] Only when PID module is operated under right operating conditions, lifetime in this spec can be guaranteed.

After the module's end of life, it is not harmful in case of normal operation and storage.

**7.3 SAFETY STANDARDS**

The LCD module should be certified with safety regulations as follows:

Regulatory	Item	Standard
Information Technology equipment	UL	UL60950-1:2006 or Ed.2:2007
	cUL	CAN/CSA C22.2 No.60950-1-03 or 60950-1-07
	CB	IEC60950-1:2005 / EN60950-1:2006+ A11:2009
Audio/Video Apparatus	UL	UL60065 Ed.7:2007
	cUL	CAN/CSA C22.2 No.60065-03:2006 + A1:2006
	CB	IEC60065:2001+ A1:2005 / EN60065:2002 + A1:2006+ A11:2008

If the module displays the same pattern for a long period of time, the phenomenon of image sticking may be occurred.

8. DEFINITION OF LABELS

8.1 MODULE LABEL

The barcode nameplate is pasted on each module as illustration, and its definitions are as following explanation.



- (a) Model Name: S231AJ1-LE1
- (b) Revision: Rev. XX, for example: A0, A1... B1, B2... or C1, C2... etc.
- (c) Serial ID: XXXXXYYMDLNNNN

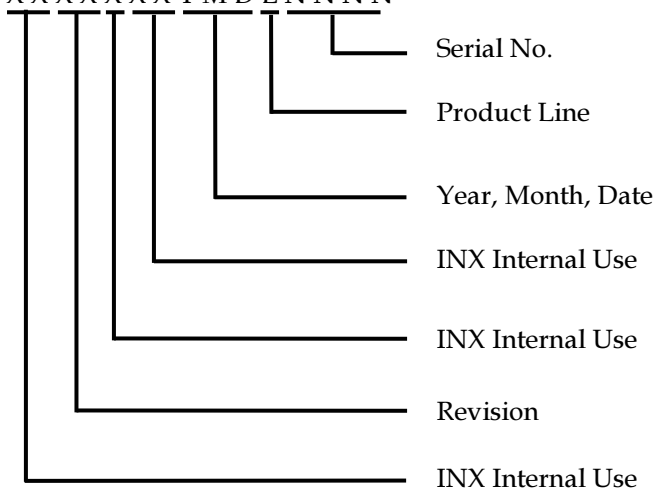

Serial ID includes the information as below:

- (b) Manufactured Date: Year: 0~9, for 2010~2019  
Month: 1~9, A~C, for Jan. ~ Dec.  
Day: 1~9, A~Y, for 1<sup>st</sup> to 31<sup>st</sup>, exclude I ,O, and U.
- (c) Revision Code: Cover all the change
- (d) Serial No.: Manufacturing sequence of product
- (e) Product Line: 1 → Line1, 2 → Line 2, ... etc.

8.2 CARTON LABEL

The barcode nameplate is pasted on each box as illustration, and its definitions are as following explanation.

P.O. NO. _____	
Parts ID. _____	
Model Name <u>  S231AJ1-LE1  </u>	
Carton ID. _____	 Quantities <u>  ____  </u>
XXXXXXXXXXXXXXXXXX	
Made In Taiwan (Made In China)	

Model Name: S231AJ1-LE1

Carton ID: X X X X X X Y M D X X X X

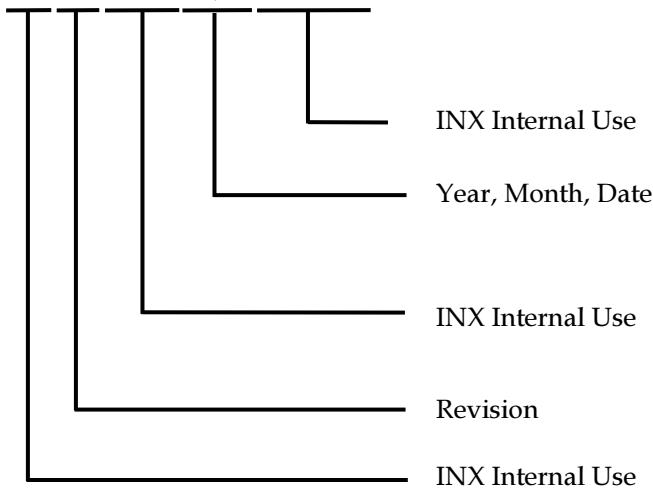

Serial ID includes the information as below :

Manufactured Date:

Year: 2010=0, 2011=1, 2012=2...etc.

Month: 1~9, A~C, for Jan. ~ Dec.

Day: 1~9, A~Y, for 1st to 31st, exclude I, O, and U.

Revision Code: Cover all the change

**9. PACKAGING**

**9.1 PACKAGING SPECIFICATIONS**

**TBD**

**9.2 PACKAGING METHOD**

**TBD**

**9.3 UN-PACKAGING METHOD (type-A)**

10. MECHANICAL CHARACTERISTIC

**TBD**