

S-2934AR/I

CMOS 4K-bit serial E²PROM Compatible with NMC93C66, NS code

The S-2934AR/I is a high speed, low power 4K-bit E²PROM that uses the CMOS floating-gate process. The organization is 256-word × 16-bit, and it is read or written serially.

■ Features

- Low power consumption
Operating: 2.0 mA max.
Standby: 1.0 μ A max.
- Wide operating voltage range
Write : 2.7 to 6.5 V
Read : 1.8 to 6.5 V
- Write operation with built-in timer
- Word/chip erase operation
- Rewritings: 10⁴ or 10⁵ times
- Data retention: 10 years
- Compatible with National Semiconductor NMC93C66 (DIP)

■ Pin Arrangement

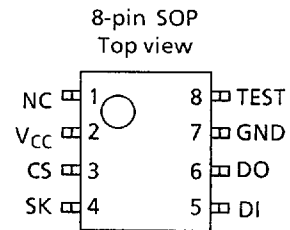
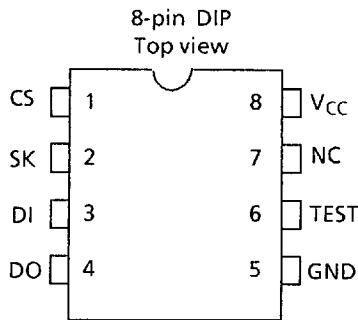

CS	Chip select
SK	Serial clock
DI	Serial data input
DO	Serial data output
GND	Ground (0 V)
V _{CC}	Power supply voltage (+ 5 V)
TEST	Test Usually open. When it is used, connect to GND or V _{CC}

Figure 1

S-2934AR/I

■ Block Diagram

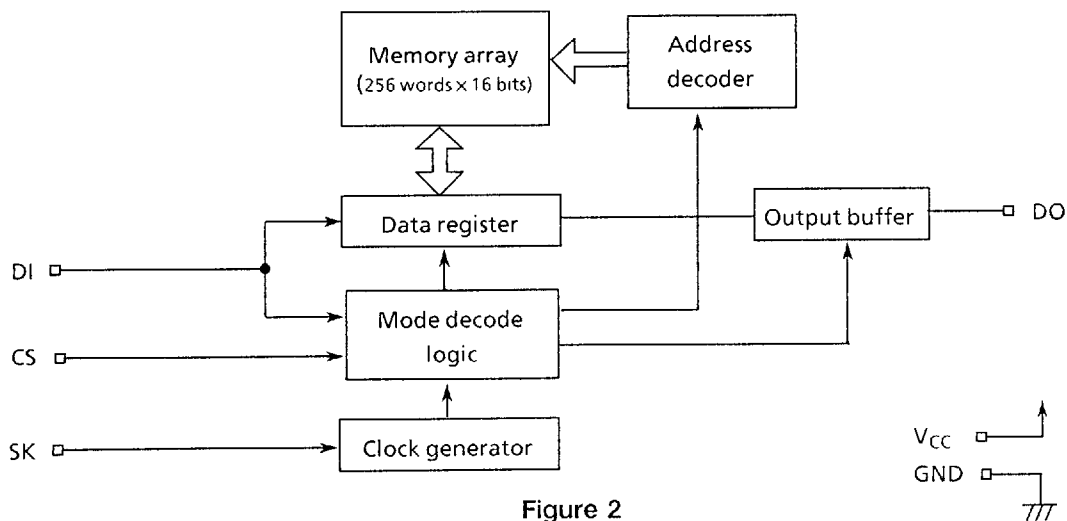

Figure 2

■ Instruction Set

Table 1

Instruction	Start bit	Op code	Address	Data
READ (Read data)	1	10	A ₇ to A ₀	D ₁₅ to D ₀
WRITE (Write data)	1	01	A ₇ to A ₀	D ₁₅ to D ₀
WRAL (Write all)	1	00	01xxxxxx	D ₁₅ to D ₀
ERASE (Erase data)	1	11	A ₇ to A ₀	—
ERAL (Erase all)	1	00	10xxxxxx	—
EWEN (Program enable)	1	00	11xxxxxx	—
EWDS (Program disable)	1	00	00xxxxxx	—

x : Don't care

■ Absolute Maximum Ratings

Table 2

Item	Symbol	Conditions	Ratings	Unit
Power supply voltage	V_{CC}		-0.3 to +7.0	V
Input voltage	V_{IN}		-0.3 to $V_{CC} + 0.3$	V
Output voltage	V_{OUT}		-0.3 to V_{CC}	V
Storage temperature under bias	T_{bias}	S-2934AR	-10 to +85	°C
		S-2934AI	-50 to +95	°C
Storage temperature	T_{stg}	S-2934AR	-65 to +125	°C
		S-2934AI	-65 to +150	°C

■ Recommended Operating Conditions

Table 3

Item	Symbol	Conditions	Min.	Typ.	Max.	Unit
Power supply voltage	V_{CC}	Read	1.8	—	6.5	V
		Write	2.7	—	6.5	V
High level input voltage	V_{IH}	$V_{CC} = 5.0 \pm 10\%$	2.0	—	V_{CC}	V
		$V_{CC} = 2.7$ to $6.5V$	$0.8 \times V_{CC}$	—	V_{CC}	V
		$V_{CC} = 1.8$ to $2.7V$	$0.8 \times V_{CC}$	—	V_{CC}	V
Low level input voltage	V_{IL}	$V_{CC} = 5.0 \pm 10\%$	0.0	—	0.8	V
		$V_{CC} = 2.7$ to $6.5V$	0.0	—	$0.15 \times V_{CC}$	V
		$V_{CC} = 1.8$ to $2.7V$	0.0	—	$0.2 \times V_{CC}$	V
Operating temperature	T_{opr}	S-2934AR	0	—	+70	°C
		S-2934AI	-40	—	+85	°C

S-2934AR/I

DC Electrical Characteristics

Table 4

(S-2934AR Ta = 0°C to 70°C, S-2934AI Ta = -40°C to 85°C)

Item	SmbI	Conditions	Read/write operations						Read operation			Unit
			V _{CC} = 5.0 V ± 10 %			V _{CC} = 3.0 V ± 10 %			V _{CC} = 1.8 to 2.7 V			
			Min	Typ	Max	Min	Typ	Max	Min	Typ	Max	
Current consumption (READ)	I _{CC1}	DO unloaded	—	—	2.0	—	—	1.0	—	—	0.5	mA
Current consumption (PROGRAM)	I _{CC2}	DO unloaded	—	—	5.0	—	—	2.0	—	—	—	mA

Table 5

(S-2934AR Ta = 0°C to 70°C, S-2934AI Ta = -40°C to 85°C)

Item	SmbI	Conditions	Read/write operations						Read operation			Unit
			V _{CC} = 5.0 V ± 10 %			V _{CC} = 2.7 to 6.5 V			V _{CC} = 1.8 to 2.7 V			
			Min	Typ	Max	Min	Typ	Max	Min	Typ	Max	
Standby current consumption	I _{SB}	Input V _{CC} or GND	—	—	1.0	—	—	1.0	—	—	1.0	μA
Input leakage current	I _{LI}	V _{IN} = GND to V _{CC}	—	0.1	1.0	—	0.1	1.0	—	0.1	1.0	μA
Output leakage current	I _{LO}	V _{OUT} = GND to V _{CC}	—	0.1	1.0	—	0.1	1.0	—	0.1	1.0	μA
Low level output voltage	V _{OL}	CMOS I _{OL} = 100 μA	—	—	0.1	—	—	0.1	—	—	0.1	V
		TTL I _{OL} = 2.1 mA	—	—	0.45	—	—	—	—	—	—	V
High level output voltage	V _{OH}	CMOS V _{CC} = 2.7 to 6.5 V, I _{OH} = -100 μA V _{CC} = 1.8 to 2.7 V, I _{OH} = -10 μA	V _{CC} -0.7	—	—	V _{CC} -0.7	—	—	V _{CC} -0.3	—	—	V
		TTL, I _{OH} = -400 μA	2.4	—	—	—	—	—	—	—	—	V
Write enable latch data hold voltage	V _{DH}		1.5	—	—	1.5	—	—	1.5	—	—	V

Rewriting Times

Table 6

(S-2934AR : Ta = 0°C to 70°C, S-2934AI : Ta = -40°C to 85°C)

Item	Symbol	Conditions	Min.	Typ.	Max.	Unit
Rewriting times	N _W	S-2934AR/I01	10 ⁴	—	—	times/word
		S-2934AR/I10	10 ⁵	—	—	times/word

Pin Capacitance

Table 7

(Ta = 25°C, f = 1.0 MHz, V_{CC} = 5 V)

Item	Symbol	Conditions	Min.	Typ.	Max.	Unit
Input capacitance	C _{IN}	V _{IN} = 0 V	—	—	6	pF
Output capacitance	C _{OUT}	V _{OUT} = 0 V	—	—	10	pF

■ AC Electrical Characteristics

Table 8 Measuring conditions

Input voltage level	$0.1 \times V_{CC}$ to $0.9 \times V_{CC}$
Output voltage level	$0.5 \times V_{CC}$
Output load	100pF

Table 9

(S-2934AR : Ta = 0°C to 70°C, S-2934AI : Ta = -40°C to 85°C)

Item	Symbol	Read / Write operations						Read operation			Unit
		$V_{CC} = 5.0 \pm 10\%$			$V_{CC} = 2.7$ to 6.5 V			$V_{CC} = 1.8$ to 2.7 V			
		Min.	Typ.	Max.	Min.	Typ.	Max.	Min.	Typ.	Max.	
CS setup time	t_{CSS}	0.2	—	—	0.4	—	—	1.0	—	—	μ s
CS hold time	t_{CSH}	0.2	—	—	0.4	—	—	1.0	—	—	μ s
CS deselect time	t_{CDS}	0.2	—	—	0.2	—	—	0.4	—	—	μ s
Data setup time	t_{DS}	0.2	—	—	0.4	—	—	0.8	—	—	μ s
Data hold time	t_{DH}	0.2	—	—	0.4	—	—	0.8	—	—	μ s
1 data output delay	t_{PD1}	—	—	0.4	—	—	1.0	—	—	2.0	μ s
0 data output delay	t_{PD0}	—	—	0.4	—	—	1.0	—	—	2.0	μ s
Clock frequency	f_{SK}	0.0	—	2.0	0.0	—	0.5	0.0	—	0.2	MHz
Clock pulse width	t_{SKH}, t_{SKL}	0.25	—	—	1.0	—	—	2.5	—	—	μ s
Output disable time	t_{HZ}	0	50	150	0	500	1000	—	—	—	ns
Output enable time	t_{SV}	0	50	150	0	500	1000	—	—	—	ns
Program time	t_{PR}	2.0	4.0	10	2.0	4.0	10	—	—	—	ms

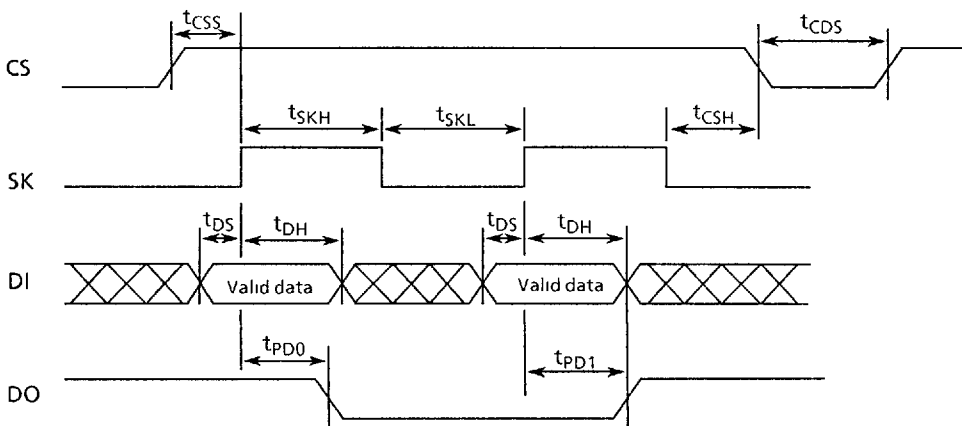

Figure 3 Timing chart

■ Operation

Note

- CS must be "L" between instructions.
- SK and DI must be "L" during verify operation.
- It is not necessary to erase data before WRITE or WRAL operation.

(1) Read mode

This mode reads data from a specified address. By the READ instruction, data is triggered at the rise of SK, and output serially to the DO pin.

The READ instruction is executed regardless of program enable or disable mode.

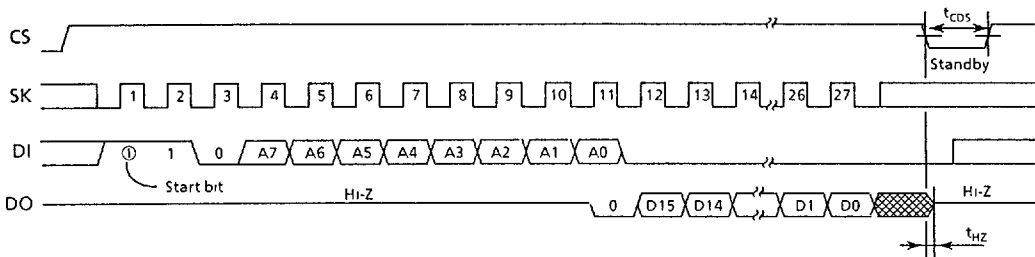

Figure 4 Read mode timing

(2) Write data mode

After the WRITE instruction, address and data are sent in program enable mode, CS must be low once. At the falling edge of its low, write operation of data in the specified address is started. This operation is performed by the internal auto-timing generation circuit and the SK is not necessary. The READY/BUSY status can be found by CS high level and checking DO pin. During write operation, low level is output to the DO pin, and after operation, high level is output.

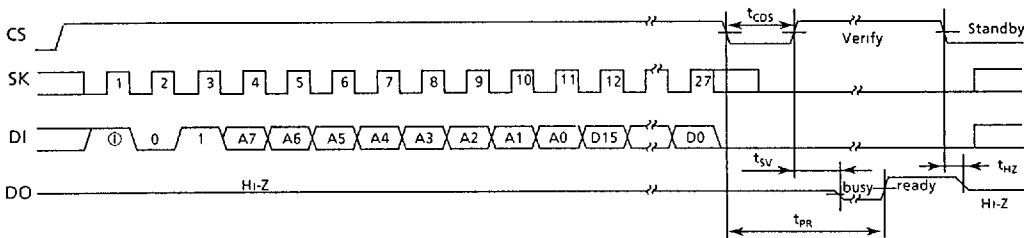

Figure 5 Write data mode timing

(3) Write all (WRAL) mode

After the WRAL instruction is sent, in program enable mode, CS must be low once. At the falling edge of its low, write operation is started, and the same data is written into all memory array bits. This operation is performed by the internal auto-timing generation circuit and SK is not necessary. The READY/BUSY status can be found by CS high level and checking DO pin. During write operation, low level is output to the DO pin, and after operation, high level is output.

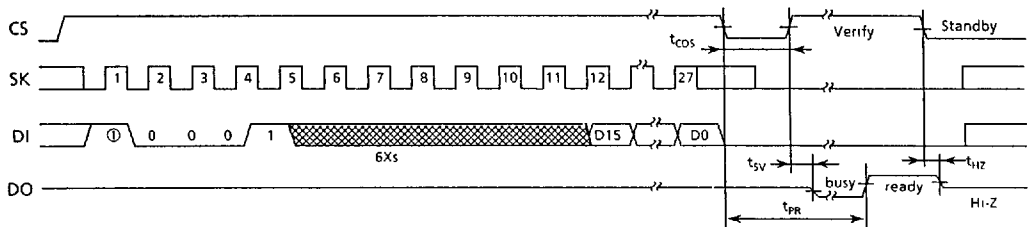

Figure 6 WRAL mode timing

(4) Erase data mode

After the ERASE instruction and address are sent in program enable mode, CS must be low once. At the falling edge of its low, erase operation of data in the specified address is started. This operation is performed by the internal auto-timing generation circuit and SK is not necessary. The READY/BUSY status can be found by CS high level and checking DO pin. During erase operation, low level is output to the DO pin, and after operation, high level is output.

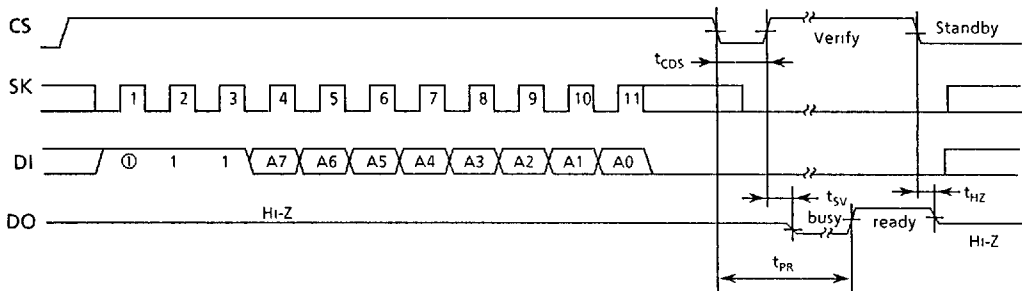

Figure 7 Erase data mode timing

S-2934AR/I

(5) Erase all (ERAL) mode

After the ERAL instruction is sent, in program enable mode, CS must be low once. At the falling edge of its low, erase operation of all memory array bits is started, and set to 1. This operation is performed by the internal auto-timing generation circuit and SK is not necessary. The READY/BUSY status can be found by CS high level and checking DO pin. During erase operation, low level is output to the DO pin, and after operation, high level is output.

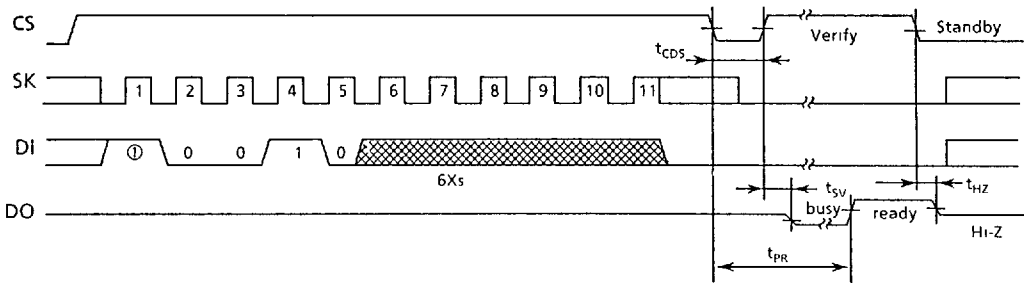

Figure 8 ERAL mode timing

(6) Program enable (EWEN) and program disable (EWDS) modes

The EWEN instruction puts the S-2934AR/I into program enable (EWEN) mode. In this mode, WRITE, WRAL, ERASE and ERAL instructions are enabled. The S-2934AR/I remains in EWEN mode until an EWDS instruction is executed. The EWDS instruction puts the S-2934AR/I into program disable (EWDS) mode. The WRITE, WRAL, ERASE and ERAL instructions are ignored in the EWDS mode; this mode is used to protect data against accidental programming. The S-2934AR/I is in program disable mode when power is turned on.

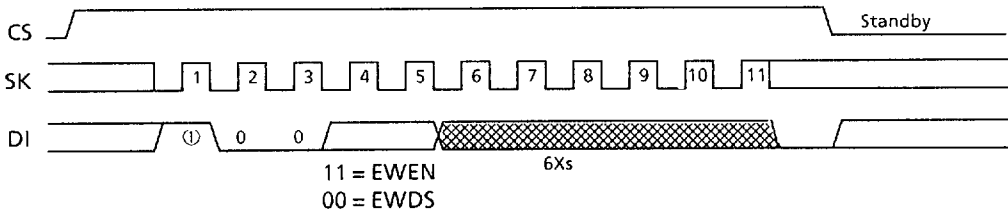

Figure 9 EWEN/EWDS mode timing

■ Dimensions (Unit:mm)

1. S-2934AR/I (8-pin DIP)

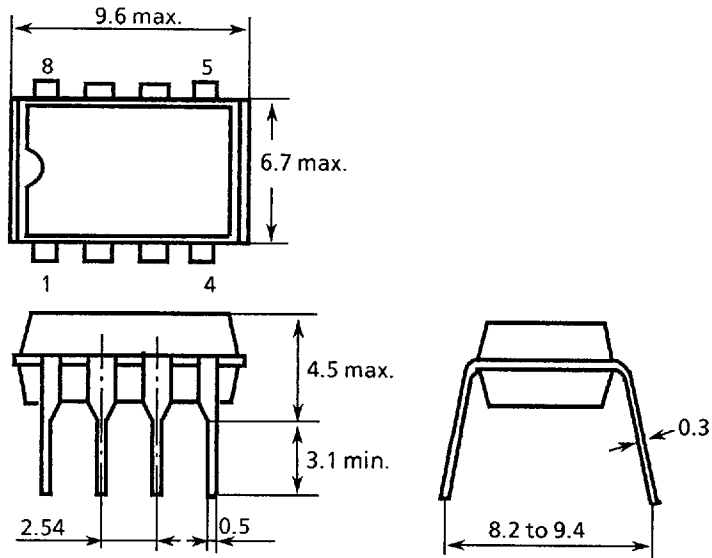

Figure 10

2. S-2934ARF/IF (8-pin SOP)

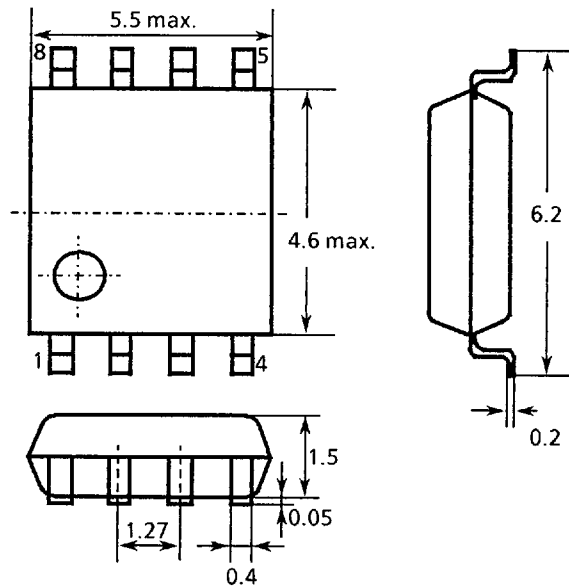

Figure 11

S-2934AR/I

Ordering Information

Table 10

Product name	Rewritings / word	Temperature	Package
S-2934AR01	10 ⁴	0°C to 70°C	DIP plastic
S-2934ARF01	10 ⁴	0°C to 70°C	SOP plastic
S-2934AI01	10 ⁴	-40°C to 85°C	DIP plastic
S-2934AIF01	10 ⁴	-40°C to 85°C	SOP plastic
S-2934AR10	10 ⁵	0°C to 70°C	DIP plastic
S-2934ARF10	10 ⁵	0°C to 70°C	SOP plastic
S-2934AI10	10 ⁵	-40°C to 85°C	DIP plastic
S-2934AIF10	10 ⁵	-40°C to 85°C	SOP plastic

Note : Each bit is set to 1 before delivery.

Markings

1. S-2934AR/I (8-pin DIP)

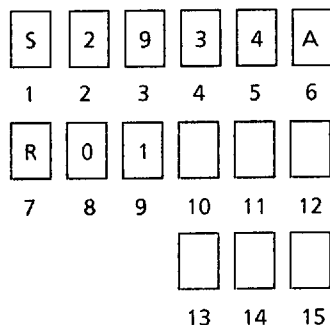

- 1 to 6 : Product name
- 7 : Temperature : R = 0 to 70°C, I = -40 to 85°C
- 8 to 9 : Min. rewriting time : 01 = 10⁴, 10 = 10⁵
- 10 to 12 : Lot No.
- 13 : Assembly mark
- 14 : Last column of year
- 15 : Month of manufacture: January = 1, February = 2, March = 3, April = 4, May = 5, June = 6, July = 7, August = 8, September = 9, October = X, November = Y, December = Z

2. S-2934ARF/IF (8-pin SOP)

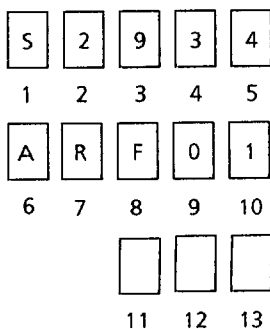

- 1 to 6 : Product name
- 7 : Temperature : R = 0 to 70°C, I = -40 to 85°C
- 8 : Package : F = SOP
- 9 to 10 : Min. rewriting time : 01 = 10⁴, 10 = 10⁵
- 11 : Month of manufacture: January = 1, February = 2, March = 3, April = 4, May = 5, June = 6, July = 7, August = 8, September = 9, October = X, November = Y, December = Z
- 12 to 13 : Lot No.

■ Characteristics

1. DC Characteristics

1.1 Current consumption (READ) I_{CC1} — Ambient temperature T_a

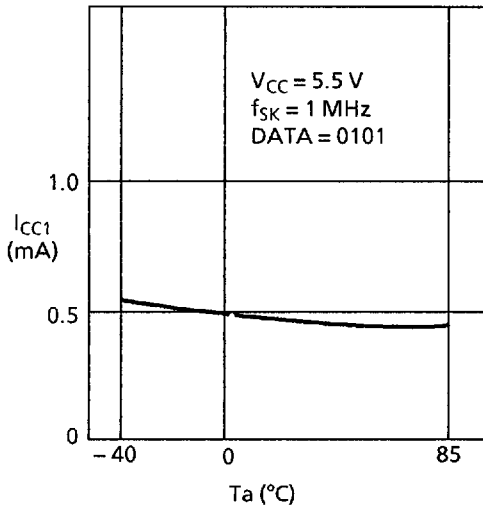

1.2 Current consumption (READ) I_{CC1} — Power supply voltage V_{CC}

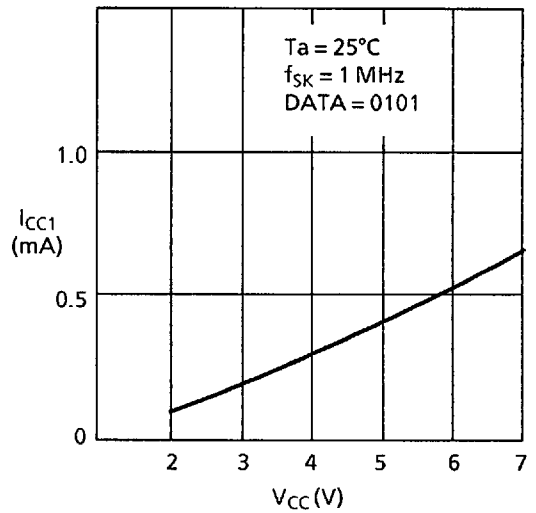

1.3 Current consumption (READ) I_{CC1} — Clock frequency f_{SK}

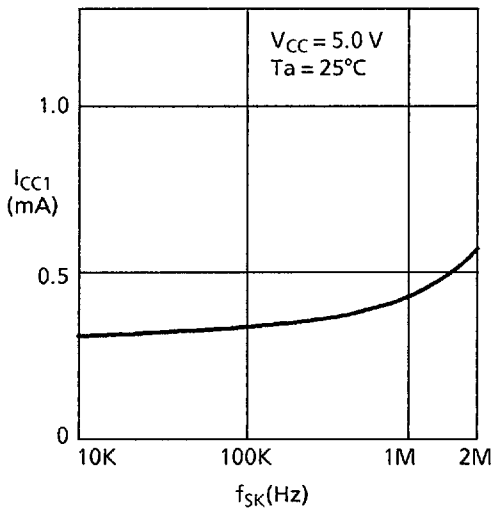

S-2934AR/I

1.4 Current consumption (PROGRAM) I_{CC2} - Ambient temperature T_a

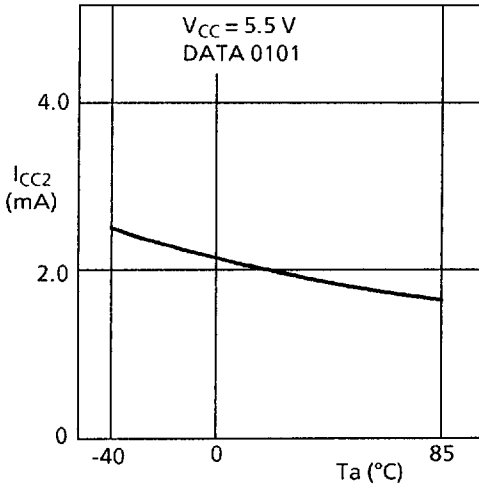

1.5 Current consumption (PROGRAM) I_{CC2} - Power supply voltage V_{CC}

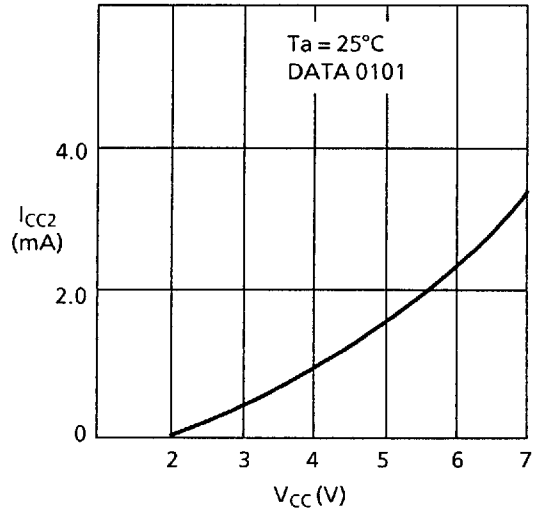

1.6 Standby current consumption I_{SB} - Ambient temperature T_a

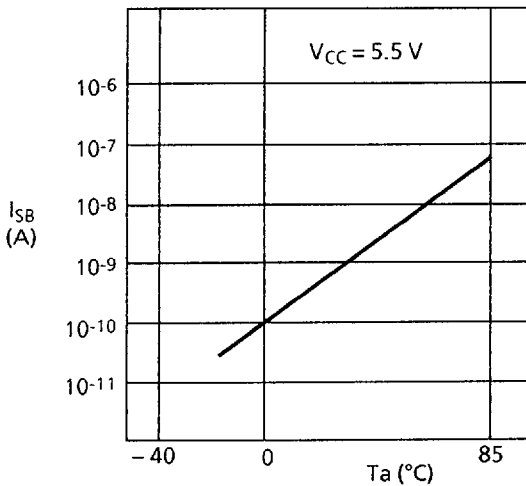

1.7 Input leakage current I_{LI} – Ambient temperature T_a

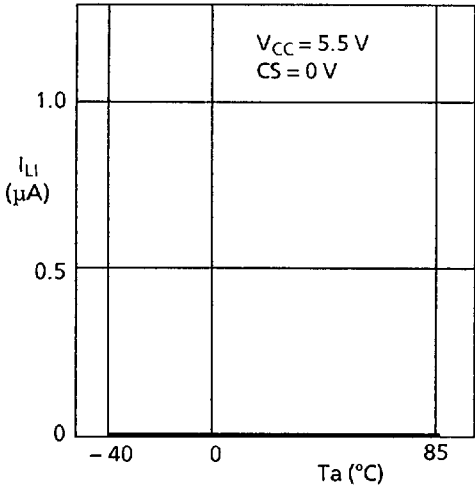

1.8 Input leakage current I_{LI} – Ambient temperature T_a

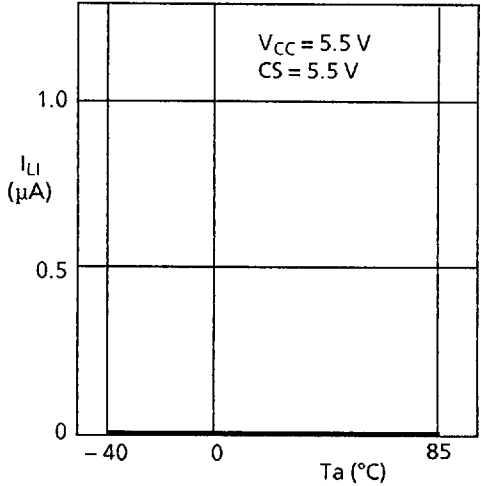

1.9 Output leakage current I_{LO} – Ambient temperature T_a

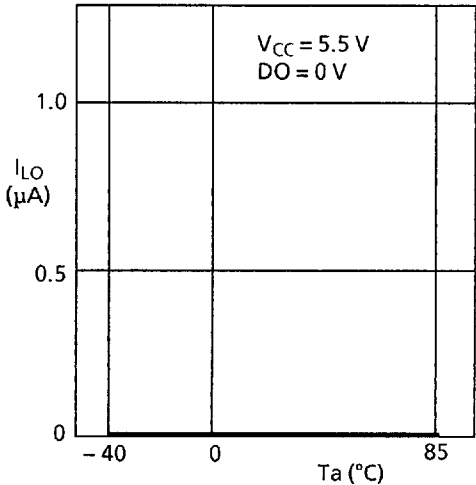

1.10 Output leakage current I_{LO} – Ambient temperature T_a

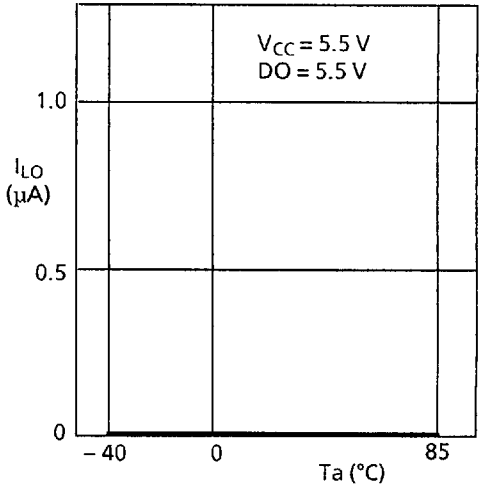

S-2934AR/I

1.11 High level output voltage V_{OH} - Ambient temperature T_a

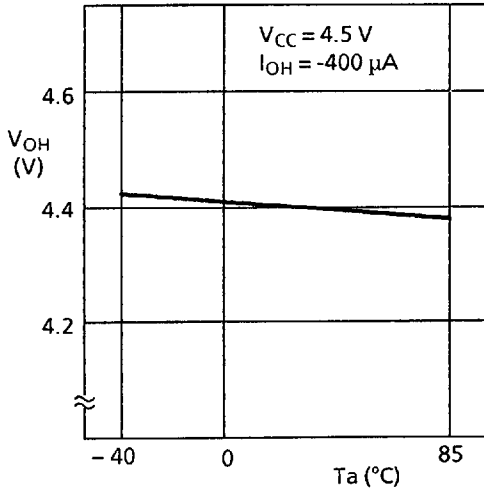

1.12 Low level output voltage V_{OL} - Ambient temperature T_a

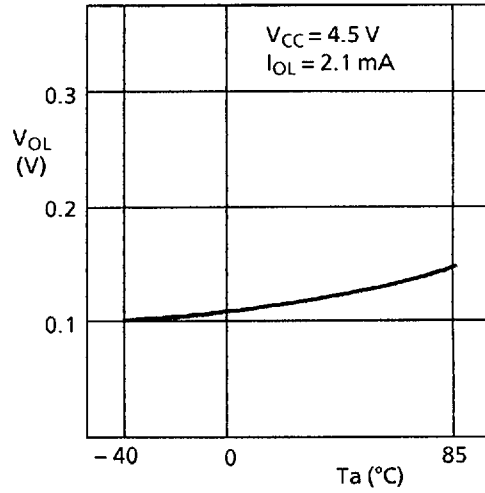

1.13 High level output current I_{OH} - Ambient temperature T_a

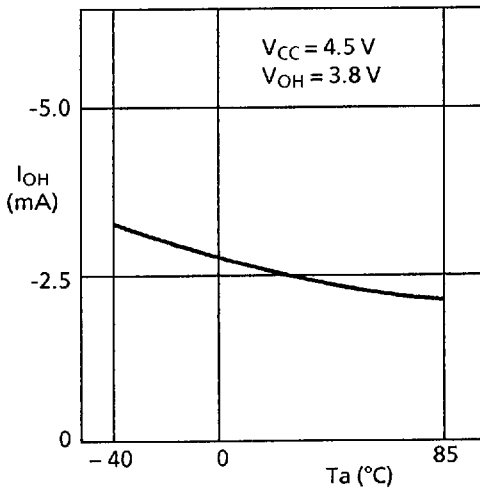

1.14 Low level output current I_{OL} - Ambient temperature T_a

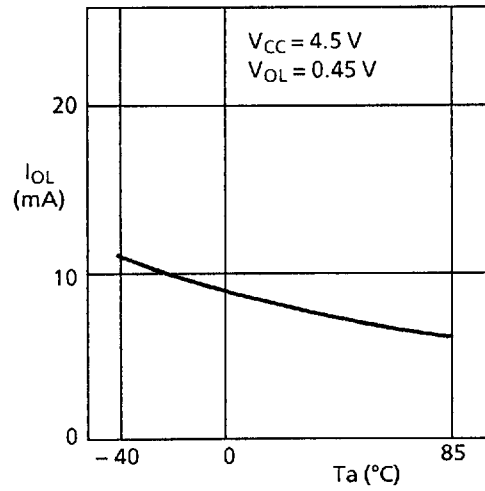

1.15 Input voltage V_{IN} -
Power supply voltage V_{CC}

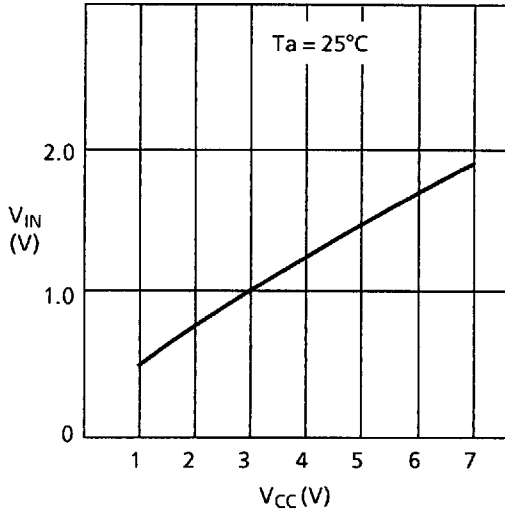

1.16 Input voltage V_{IN} -
Ambient temperature T_a

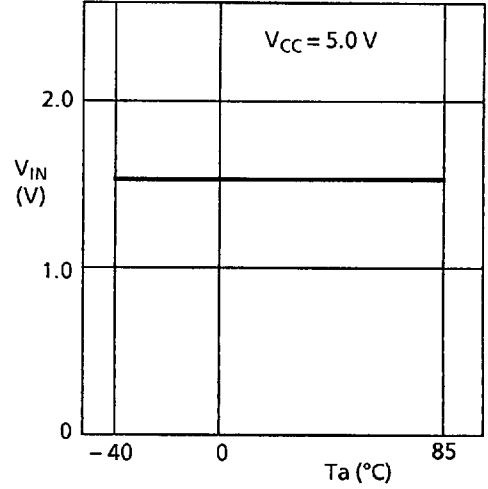

S-2934AR/I

2. AC Characteristics

2.1 Program time t_{PR} – Power supply voltage V_{CC}

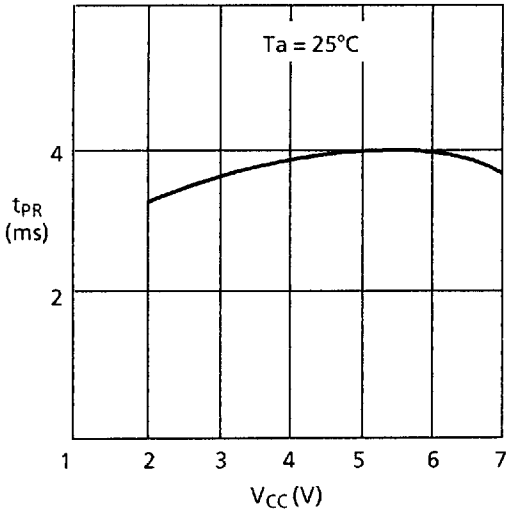

2.2 Program time t_{PR} – Ambient temperature T_a

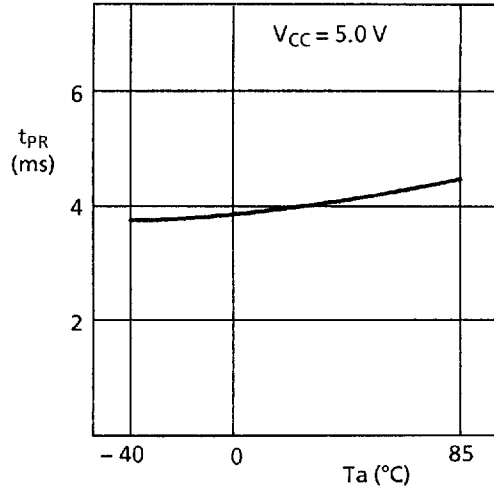

2.3 1 data output delay time t_{PD1} – Ambient temperature T_a

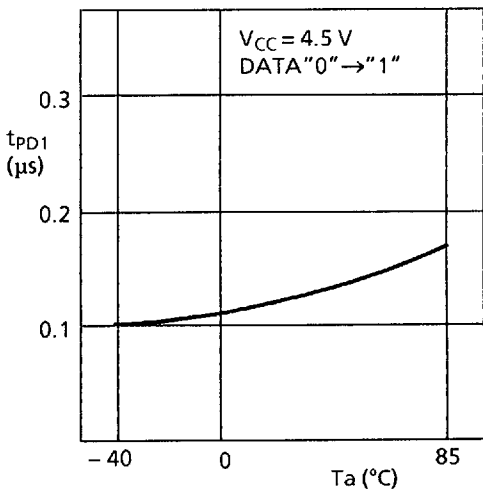

2.4 0 data output delay time t_{PD0} – Ambient temperature T_a

