



**2 MEGABIT (262,144 x 8 BIT)
5 VOLT CMOS FLASH MEMORY**

Features

- 256Kx8-bit Organization
- Address Access Time: 70, 90, 120, 150 ns
- Single 5V ± 10% Power Supply
- Sector Erase Mode Operation
- 16KB Boot Block (lockable)
- 512 bytes per Sector, 512 Sectors
 - Sector-Erase Cycle Time: 10ms (Max)
 - Byte-Write Cycle Time: 35µs (Max)
- Minimum 10,000 Erase-Program Cycles
- Low power dissipation
 - Active Read Current: 20mA (Typ)
 - Active Program Current: 30mA (Typ)
 - Standby Current: 100µA (Max)
- Hardware Data Protection
- Low V_{CC} Program Inhibit Below 3.5V
- Self-timed write/erase operations with end-of-cycle detection
 - $\overline{\text{DATA}}$ Polling
 - Toggle Bit
- CMOS and TTL Interface
- Available in one versions
 - S29C51002T (Top Boot Block)

- Packages:
 - 32-pin Plastic DIP
 - 32-pin TSOP-I
 - 32-pin PLCC

Description

The S29C51002T/S29C51002B is a high speed 262,144 x 8 bit CMOS flash memory. Writing or erasing the device is done with a single 5 Volt power supply. The device has separate chip enable $\overline{\text{CE}}$, write enable $\overline{\text{WE}}$, and output enable $\overline{\text{OE}}$ controls to eliminate bus contention.

The S29C51002T/S29C51002B offers a combination of: Boot Block with Sector Erase/Write Mode. The end of write/erase cycle is detected by $\overline{\text{DATA}}$ Polling of I/O₇ or by the Toggle Bit I/O₆.

The S29C51002T/S29C51002B features a sector erase operation which allows each sector to be erased and reprogrammed without affecting data stored in other sectors. The device also supports full chip erase.

Boot block architecture enables the device to boot from a protected sector located either at the top (S29C51002T) or the bottom (S29C51002B). All inputs and outputs are CMOS and TTL compatible.

The S29C51002T/S29C51002B is ideal for applications that require updatable code and data storage.



**2 MEGABIT (262,144 x 8 BIT)
5 VOLT CMOS FLASH MEMORY**

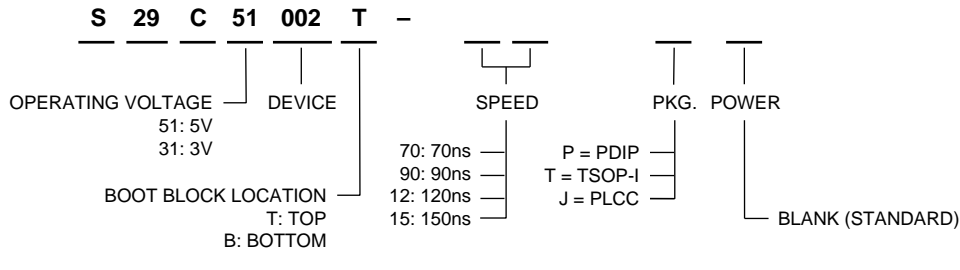

51002-01

Pin Configurations

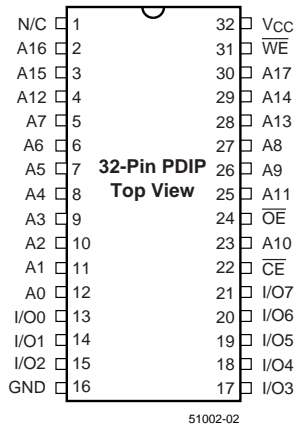

51002-02

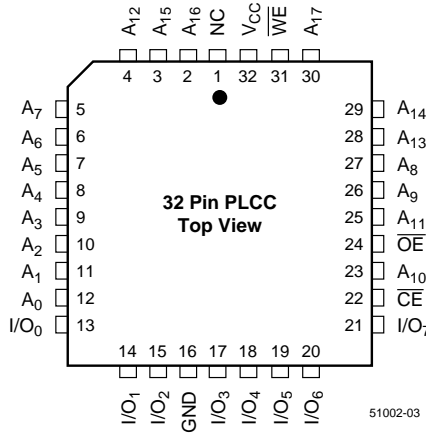

51002-03

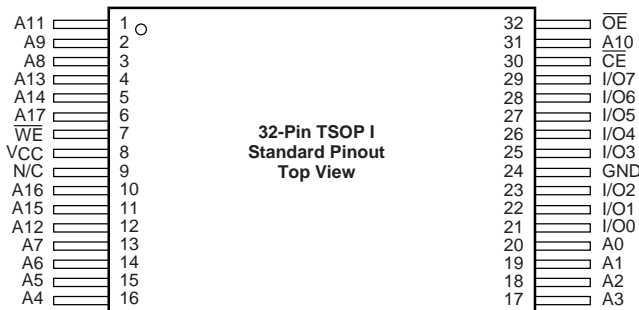

51002-04

Pin Names

A ₀ -A ₁₇	Address Inputs
I/O ₀ -I/O ₇	Data Input/Output
CE	Chip Enable
OE	Output Enable
WE	Write Enable
V _{CC}	5V ± 10% Power Supply
GND	Ground
NC	No Connect



**2 MEGABIT (262,144 x 8 BIT)
5 VOLT CMOS FLASH MEMORY**

Functional Block Diagram

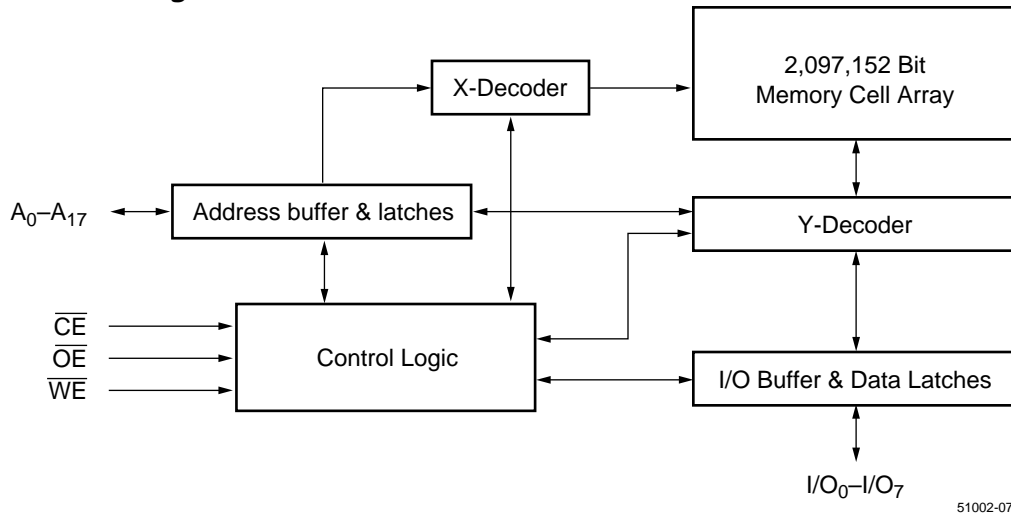

Capacitance (1,2)

Symbol	Parameter	Test Setup	Typ.	Max.	Units
C _{IN}	Input Capacitance	V _{IN} = 0	6	8	pF
C _{OUT}	Output Capacitance	V _{OUT} = 0	8	12	pF
C _{IN2}	Control Pin Capacitance	V _{IN} = 0	8	10	pF

NOTE:

1. Capacitance is sampled and not 100% tested.
2. T_A = 25°C, V_{CC} = 5V ± 10%, f = 1 MHz.

Latch Up Characteristics⁽¹⁾

Parameter	Min.	Max.	Unit
Input Voltage with Respect to GND on A ₉ , \overline{OE}	-1	+13	V
Input Voltage with Respect to GND on I/O, address or control pins	-1	V _{CC} + 1	V
V _{CC} Current	-100	+100	mA

NOTE:

1. Includes all pins except V_{CC}. Test conditions: V_{CC} = 5V, one pin at a time.

AC Test Load

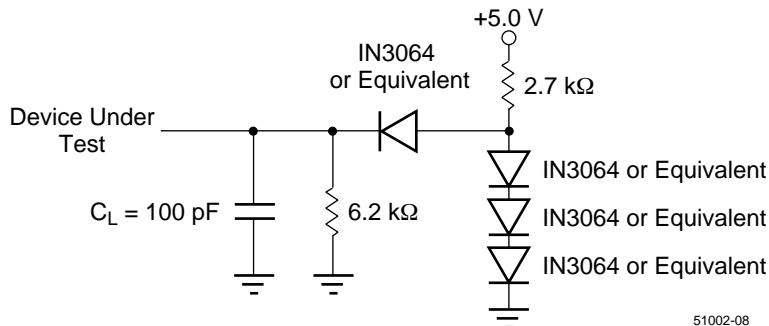



**2 MEGABIT (262,144 x 8 BIT)
5 VOLT CMOS FLASH MEMORY**

Absolute Maximum Ratings⁽¹⁾

Symbol	Parameter	Commercial	Industrial	Unit
V_{IN}	Input Voltage (input or I/O pins)	-2 to +7	-2 to +7	V
V_{IN}	Input Voltage (A_9 pin, \overline{OE})	-2 to +13	-2 to +13	V
V_{CC}	Power Supply Voltage	-0.5 to +5.5	-0.5 to +5.5	V
T_{STG}	Storage Temperature (Plastic)	-65 to +125	-65 to +150	°C
T_{OPR}	Operating Temperature	0 to +70	-40 to +85	°C
I_{OUT}	Short Circuit Current ⁽²⁾	200 (Max.)	200 (Max.)	mA

NOTE:

1. Stress greater than those listed under "Absolute Maximum Ratings" may cause permanent damage to the device. This is a stress rating only and functional operation of the device at these or any other conditions above those indicated in the operational sections of this specification is not implied. Exposure to absolute maximum rating conditions for extended periods may affect reliability.
2. No more than one output maybe shorted at a time and not exceeding one second long.

DC Electrical Characteristics

(over the commercial operating range)

Parameter Name	Parameter	Test Conditions	Min.	Max.	Unit
V_{IL}	Input LOW Voltage	$V_{CC} = V_{CC}$ Min.	—	0.8	V
V_{IH}	Input HIGH Voltage	$V_{CC} = V_{CC}$ Max.	2	—	V
I_{IL}	Input Leakage Current	$V_{IN} = GND$ to V_{CC} , $V_{CC} = V_{CC}$ Max.	—	±1	μA
I_{OL}	Output Leakage Current	$V_{OUT} = GND$ to V_{CC} , $V_{CC} = V_{CC}$ Max.	—	±10	μA
V_{OL}	Output LOW Voltage	$V_{CC} = V_{CC}$ Min., $I_{OL} = 2.1$ mA	—	0.4	V
V_{OH}	Output HIGH Voltage	$V_{CC} = V_{CC}$ Min, $I_{OH} = -400$ μA	2.4	—	V
I_{CC1}	Read Current	$\overline{CE} = \overline{OE} = V_{IL}$, $\overline{WE} = V_{IH}$, all I/Os open, Address input = V_{IL}/V_{IH} , at $f = 1/t_{RC}$ Min., $V_{CC} = V_{CC}$ Max.	—	40	mA
I_{CC2}	Write Current	$\overline{CE} = \overline{WE} = V_{IL}$, $\overline{OE} = V_{IH}$, $V_{CC} = V_{CC}$ Max.	—	50	mA
I_{SB}	TTL Standby Current	$\overline{CE} = \overline{OE} = \overline{WE} = V_{IH}$, $V_{CC} = V_{CC}$ Max.	—	2	mA
I_{SB1}	CMOS Standby Current	$\overline{CE} = \overline{OE} = \overline{WE} = V_{CC} - 0.3$ V, $V_{CC} = V_{CC}$ Max.	—	100	μA
V_H	Device ID Voltage for A_9	$\overline{CE} = \overline{OE} = V_{IL}$, $\overline{WE} = V_{IH}$	11.5	12.5	V
I_H	Device ID Current for A_9	$\overline{CE} = \overline{OE} = V_{IL}$, $\overline{WE} = V_{IH}$, $A_9 = V_H$ Max.	—	50	μA



**2 MEGABIT (262,144 x 8 BIT)
5 VOLT CMOS FLASH MEMORY**

AC Electrical Characteristics

(over all temperature ranges)

Read Cycle

Parameter Name	Parameter	-70		-90		-12		-15		Unit
		Min.	Max.	Min.	Max.	Min.	Max.	Min.	Max.	
t _{RC}	Read Cycle Time	70	—	90	—	120	—	150	—	ns
t _{AA}	Address Access Time	—	70	—	90	—	120	—	150	ns
t _{ACS}	Chip Enable Access Time	—	70	—	90	—	120	—	150	ns
t _{OE}	Output Enable Access Time	—	35	—	45	—	60	—	75	ns
t _{CLZ}	\overline{CE} Low to Output Active	0	—	0	—	0	—	0	—	ns
t _{OLZ}	\overline{OE} Low to Output Active	0	—	0	—	0	—	0	—	ns
t _{DF}	\overline{OE} or \overline{CE} High to Output in High Z	0	30	0	40	0	50	0	60	ns
t _{OH}	Output Hold from Address Change	0	—	0	—	0	—	0	—	ns

Program (Erase/Program) Cycle

Parameter Name	Parameter	-70			-90			-12			-15			Unit
		Min.	Typ.	Max.	Min.	Typ.	Max.	Min.	Typ.	Max.	Min.	Typ.	Max.	
t _{WC}	Write Cycle Time	70	—	—	90	—	—	120	—	—	150	—	—	ns
t _{AS}	Address Setup Time	0	—	—	0	—	—	0	—	—	0	—	—	ns
t _{AH}	Address Hold Time	45	—	—	45	—	—	50	—	—	50	—	—	ns
t _{CS}	\overline{CE} Setup Time	0	—	—	0	—	—	0	—	—	0	—	—	ns
t _{CH}	\overline{CE} Hold Time	0	—	—	0	—	—	0	—	—	0	—	—	ns
t _{OES}	\overline{OE} Setup Time	0	—	—	0	—	—	0	—	—	0	—	—	ns
t _{OEH}	\overline{OE} High Hold Time	0	—	—	0	—	—	0	—	—	0	—	—	ns
t _{WP}	\overline{WE} Pulse Width	35	—	—	45	—	—	50	—	—	50	—	—	ns
t _{WPH}	\overline{WE} Pulse Width High	20	—	—	30	—	—	35	—	—	35	—	—	ns
t _{DS}	Data Setup Time	30	—	—	30	—	—	30	—	—	30	—	—	ns
t _{DH}	Data Hold Time	0	—	—	0	—	—	0	—	—	0	—	—	ns
t _{WHWH1}	Programming Cycle	—	—	35	—	—	35	—	—	35	—	—	35	μs
t _{WHWH2}	Sector Erase Cycle	—	—	10	—	—	10	—	—	10	—	—	10	ms
t _{WHWH3}	Chip Erase Cycle	—	—	3.0	—	—	3.0	—	—	3.0	—	—	3.0	sec



2 MEGABIT (262,144 x 8 BIT)
5 VOLT CMOS FLASH MEMORY

Waveforms of Read Cycle

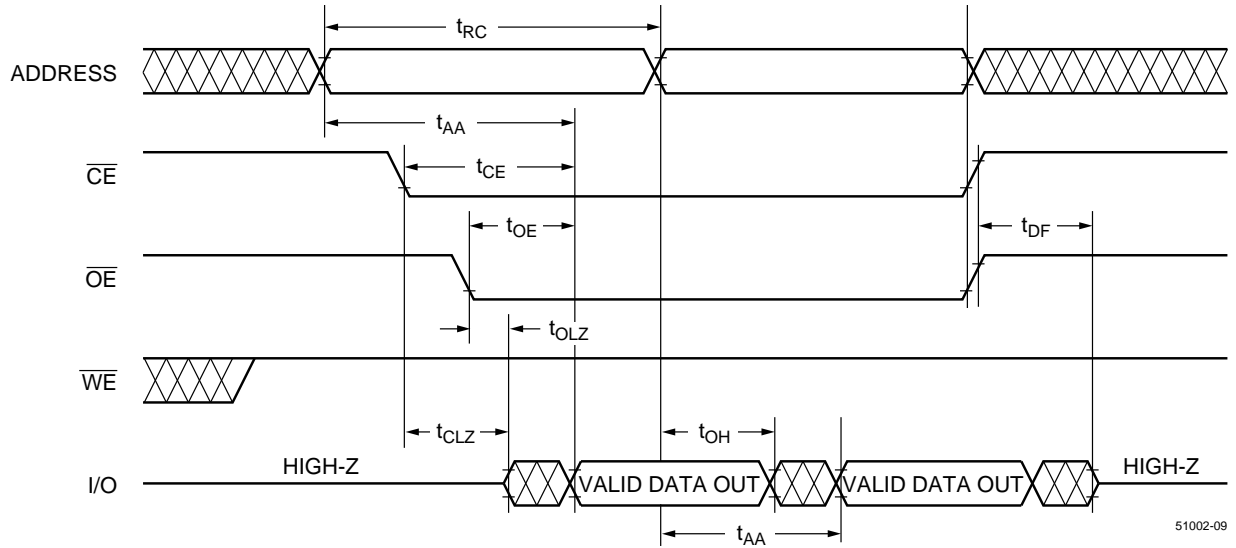

51002-09

Waveforms of \overline{WE} Controlled-Program Cycle

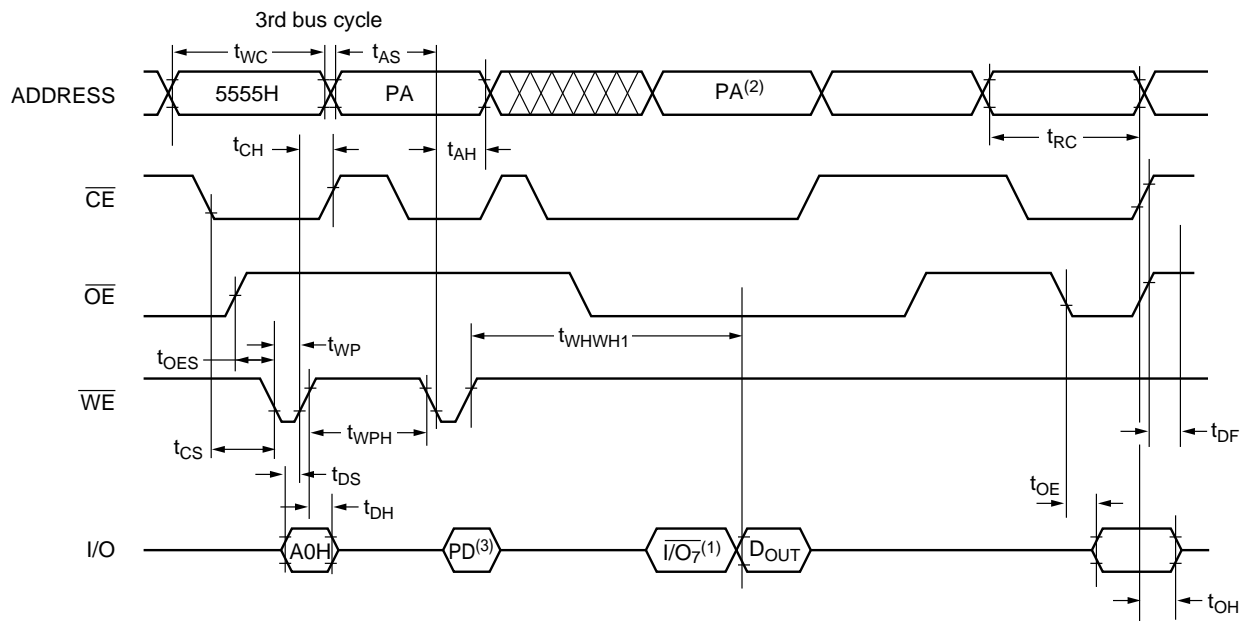

51002-10

NOTES:

1. I/O₇: The output is the complement of the data written to the device.
2. PA: The address of the memory location to be programmed.
3. PD: The data at the byte address to be programmed.



Waveforms of CE Controlled-Program Cycle

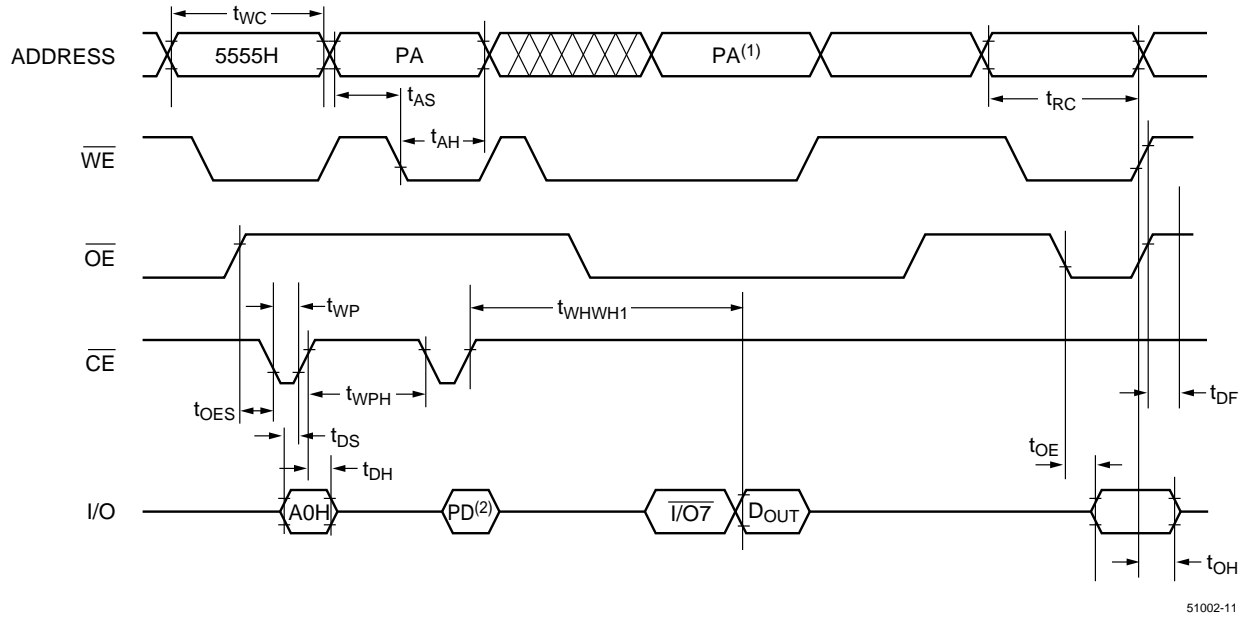

51002-11

Waveforms of Erase Cycle⁽¹⁾

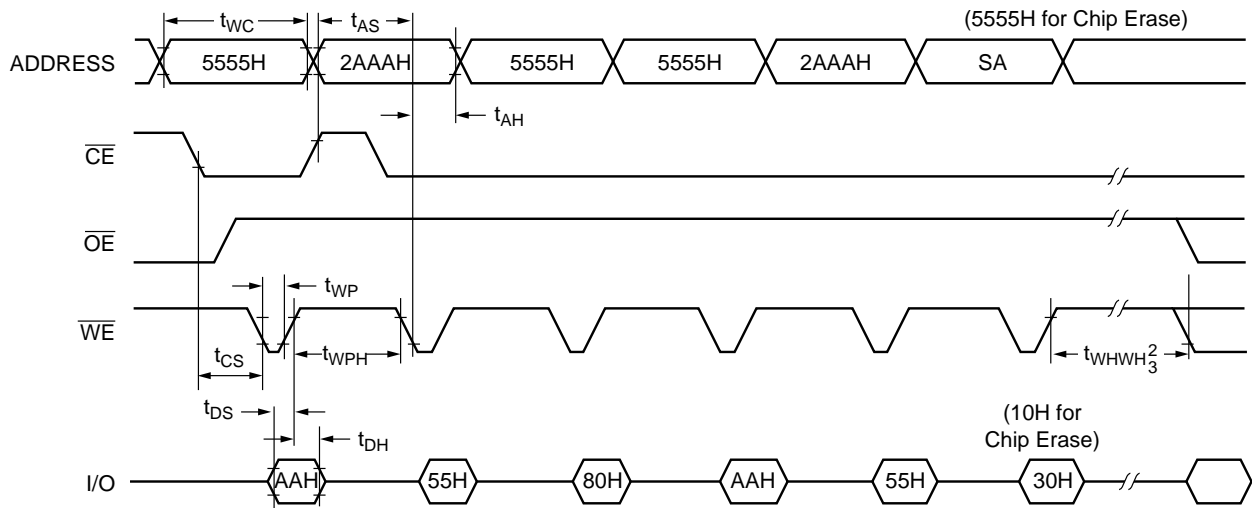

51002-12

NOTES:

1. PA: The address of the memory location to be programmed.
2. PD: The data at the byte address to be programmed.
3. SA: The sector address for Sector Erase.



Waveforms of DATA Polling Cycle

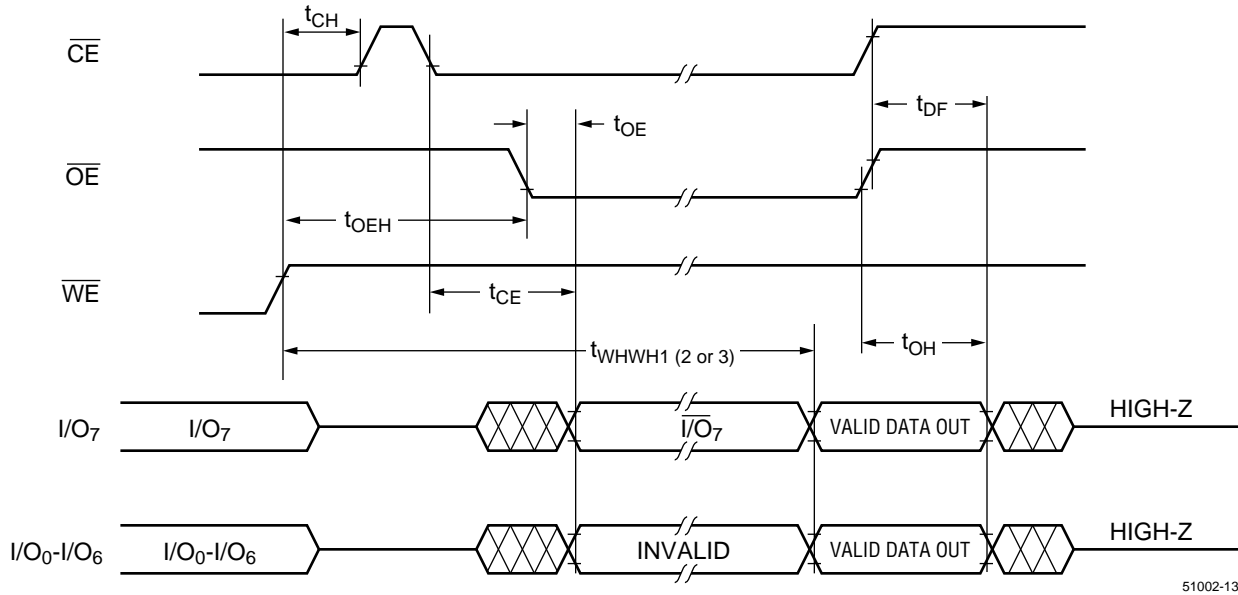

Waveforms of Toggle Bit Cycle

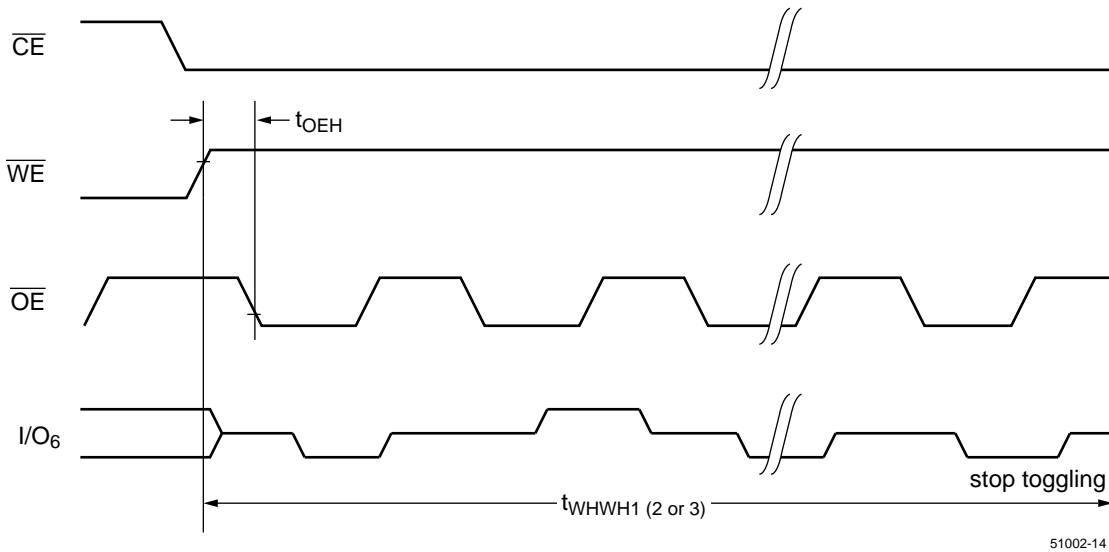



**2 MEGABIT (262,144 x 8 BIT)
5 VOLT CMOS FLASH MEMORY**

Functional Description

The S29C51002T/S29C51002B consists of 512 equally-sized sectors of 512 bytes each. The 16 KB lockable Boot Block is intended for storage of the system BIOS boot code. The boot code is the first piece of code executed each time the system is powered on or rebooted.

The S29C51002 is available in two versions: the S29C51002T with the Boot Block address starting from 3C000H to 3FFFFH, and the S29C51002B with the Boot Block address starting from 00000H to 3FFFFH.

Read Cycle

A read cycle is performed by holding both \overline{CE} and \overline{OE} signals LOW. Data Out becomes valid only when these conditions are met. During a read cycle \overline{WE} must be HIGH prior to \overline{CE} and \overline{OE} going LOW. \overline{WE} must remain HIGH during the read operation for the read to complete (see Table 1).

Output Disable

Returning \overline{OE} or \overline{CE} HIGH, whichever occurs first will terminate the read operation and place the I/O pins in the HIGH-Z state.

Standby

The device will enter standby mode when the \overline{CE} signal is HIGH. The I/O pins are placed in the HIGH-Z, independent of the \overline{OE} input state.

Byte Write Cycle

The S29C51002T/S29C51002B is programmed on a byte-by-byte basis. The byte write operation is initiated by using a specific four-bus-cycle sequence: two unlock program cycles, a program setup command and program data program cycles (see Table 2).

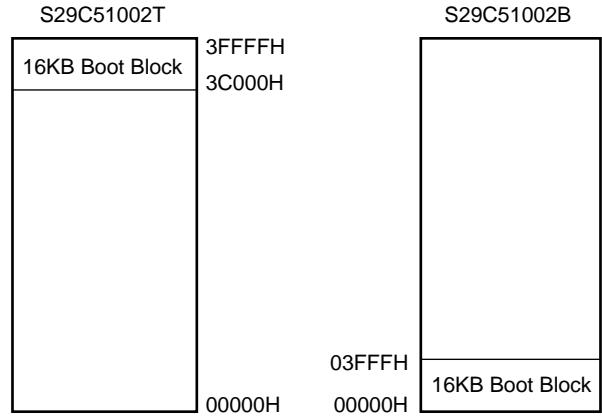

51002-15

16KB Boot Block = 32 Sectors

During the byte write cycle, addresses are latched on the falling edge of either \overline{CE} or \overline{WE} , whichever is last. Data is latched on the rising edge of \overline{CE} or \overline{WE} , whichever is first. The byte write cycle can be \overline{CE} controlled or \overline{WE} controlled.

Sector Erase Cycle

The S29C51002T/S29C51002B features a sector erase operation which allows each sector to be erased and reprogrammed without affecting data stored in other sectors. Sector erase operation is initiated by using a specific six-bus-cycle sequence: Two unlock program cycles, a setup command, two additional unlock program cycles, and the sector erase command (see Table 2). A sector must be first erased before it can be rewritten. While in the internal erase mode, the device ignores any program attempt into the device. The internal erase completion can be determined via DATA polling or toggle bit status.

The S29C51002T/S29C51002B is shipped fully erased (all bits = 1).

Table 1. Operation Modes Decoding

Decoding Mode	\overline{CE}	\overline{OE}	\overline{WE}	A ₀	A ₁	A ₉	I/O
Read	V _{IL}	V _{IL}	V _{IH}	A ₀	A ₁	A ₉	READ
Byte Write	V _{IL}	V _{IH}	V _{IL}	A ₀	A ₁	A ₉	PD
Standby	V _{IH}	X	X	X	X	X	HIGH-Z
Autoselect Device ID	V _{IL}	V _{IL}	V _{IH}	V _{IH}	V _{IL}	V _H	CODE
Autoselect Manufacture ID	V _{IL}	V _{IL}	V _{IH}	V _{IL}	V _{IL}	V _H	CODE
Enabling Boot Block Protection Lock	V _{IL}	V _H	V _{IL}	X	X	V _H	X
Disabling Boot Block Protection Lock	V _H	V _H	V _{IL}	X	X	V _H	X
Output Disable	V _{IL}	V _{IH}	V _{IH}	X	X	X	HIGH-Z

NOTES:

1. X = Don't Care, V_{IH} = HIGH, V_{IL} = LOW, V_H = 12.5V Max.
2. PD: The data at the byte address to be programmed.



**2 MEGABIT (262,144 x 8 BIT)
5 VOLT CMOS FLASH MEMORY**

Table 2. Command Codes

Command Sequence	First Bus Program Cycle		Second Bus Program Cycle		Third Bus Program Cycle		Fourth Bus Program Cycle		Fifth Bus Program Cycle		Six Bus Program Cycle	
	Address	Data	Address	Data	Address	Data	Address	Data	Address	Data	Address	Data
Read	XXXXH	F0H										
Read	5555H	AAH	2AAAH	55H	5555H	F0H	RA(1)	RD(2)				
Autoselect Mode	5555H	AAH	2AAAH	55H	5555H	90H	See table 3 for detail.					
Byte Program	5555H	AAH	2AAAH	55H	5555H	A0H	PA	PD(4)				
Chip Erase	5555H	AAH	2AAAH	55H	5555H	80H	5555H	AAH	2AAAH	55H	5555H	10H
Sector Erase	5555H	AAH	2AAAH	55H	5555H	80H	5555H	AAH	2AAAH	55H	SA(5)	30H

NOTES:

1. RA: Read Address
2. RD: Read Data
3. PA: The address of the memory location to be programmed.
4. PD: The data at the byte address to be programmed.
5. SA(5): Sector Address

Chip Erase Cycle

The S29C51002T/S29C51002B features a chip-erase operation. The chip erase operation is initiated by using a specific six-bus-cycle sequence: two unlock program cycles, a setup command, two additional unlock program cycles, and the chip erase command (see Table 2).

The automatic erase begins on the rising edge of the last \overline{WE} or \overline{CE} pulse in the command sequence and terminates when the data on DQ7 is "1".

Program Cycle Status Detection

There are two methods for determining the state of the S29C51002T/S29C51002B during a program (erase/write) cycle: \overline{DATA} Polling (I/O_7) and Toggle Bit (I/O_6).

 \overline{DATA} Polling (I/O_7)

The S29C51002T/S29C51002B features \overline{DATA} polling to indicate the end of a program cycle. When the device is in the program cycle, any attempt to read the device will receive the complement of the loaded data on I/O_7 . Once the program cycle is completed, I/O_7 will show true data, and the device is then ready for the next cycle.

Toggle Bit (I/O_6)

The S29C51002T/S29C51002B also features another method for determining the end of a program cycle. When the device is in the program cycle, any attempt to read the device will result in I/O_6 toggling between 1 and 0. Once the program is completed, the toggling will stop. The device is then ready for the next operation. Examining the toggle bit may begin at any time during a program cycle.

Boot Block Protection Enabling/Disabling

The S29C51002T/S29C51002B features hardware Boot Block Protection. The boot block sector protection is enabled when high voltage (12.5V) is applied to \overline{OE} and A9 pins with \overline{CE} pin LOW and \overline{WE} pin LOW. The sector protection is disabled when high voltage is applied to \overline{OE} , \overline{CE} and A9 pins with \overline{WE} pin LOW. Other pins can be HIGH or LOW. This is shown in table 1.

Autoselect Mode

The S29C51002T/S29C51002B features an Autoselect mode to identify boot block locking status, device ID and manufacturer ID.

Entering Autoselect mode is accomplished by applying a high voltage (VH) to the A9 Pin, or through a sequence of commands (as shown in table 2). Device will exit this mode once high voltage on A9 is removed or another command is loaded into the device.



**2 MEGABIT (262,144 x 8 BIT)
5 VOLT CMOS FLASH MEMORY**

Boot Block Protection Status

In Autoselect mode, performing a read at address location 3CXX2H (S29C51002T) or 0CXX2H (S29C51002B) will indicate boot block protection status. If the data is 01H, the boot block is protected. If the data is 00H, the boot block is unprotected. This is also shown in table 3.

Device ID

In Autoselect mode, performing a read at address XXX1H will determine whether the device is a Top Boot Block device or a Bottom Boot Block device. If the data is 02H, the device is a Top Boot Block. If the data is A2H, the device is a Bottom Boot Block device (see Table 3).

Manufacturer ID

In Autoselect mode, performing a read at address XXXX0H will determine the manufacturer ID. 40H is the manufacturer code for SyncMOS Flash.

Hardware Data Protection

V_{CC} Detection: the program operation is inhibited when VCC is less than 3.5V.

Noise Protection: a CE or WE pulse of less than 5ns will not initiate a program cycle.

Program Inhibit: holding any one of \overline{OE} LOW, \overline{CE} HIGH or \overline{WE} HIGH inhibits a program cycle.

Table 3. Autoselect Decoding

Decoding Mode	Boot Block	Address				Data I/O ₀ -I/O ₇
		A ₀	A ₁	A ₂ -A ₁₃	A ₁₄ -A ₁₇	
Boot Block Protection	Top	V _{IL}	V _{IH}	X	V _{IH}	01H: protected
	Bottom	V _{IL}	V _{IH}	X	V _{IL}	00H: unprotected
Device ID	Top	V _{IH}	V _{IL}	X	X	02H
	Bottom					A2H
Manufacture ID		V _{IL}	V _{IL}	X	X	40H

NOTE:

1. X = Don't Care, V_{IH} = HIGH, V_{IL} = LOW.



Byte Program Algorithm

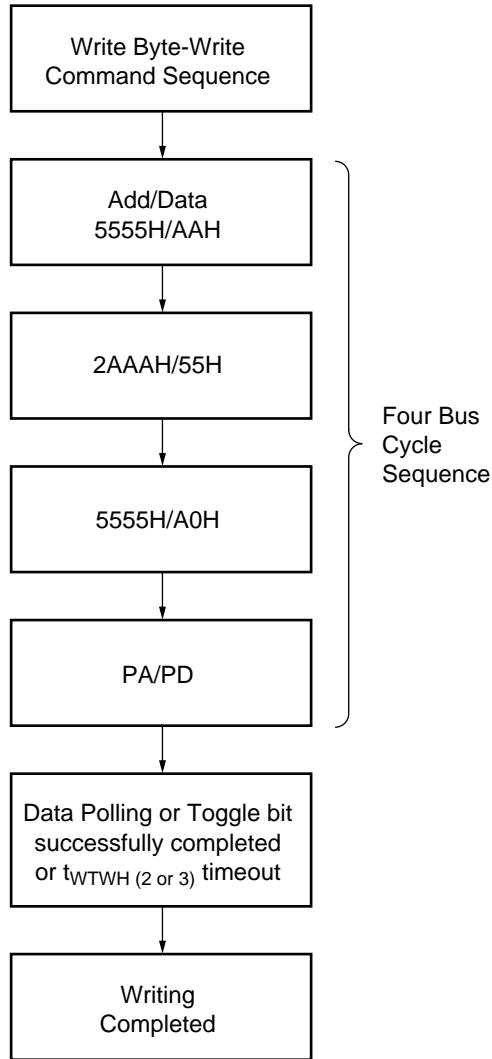

Chip/Sector Erase Algorithm

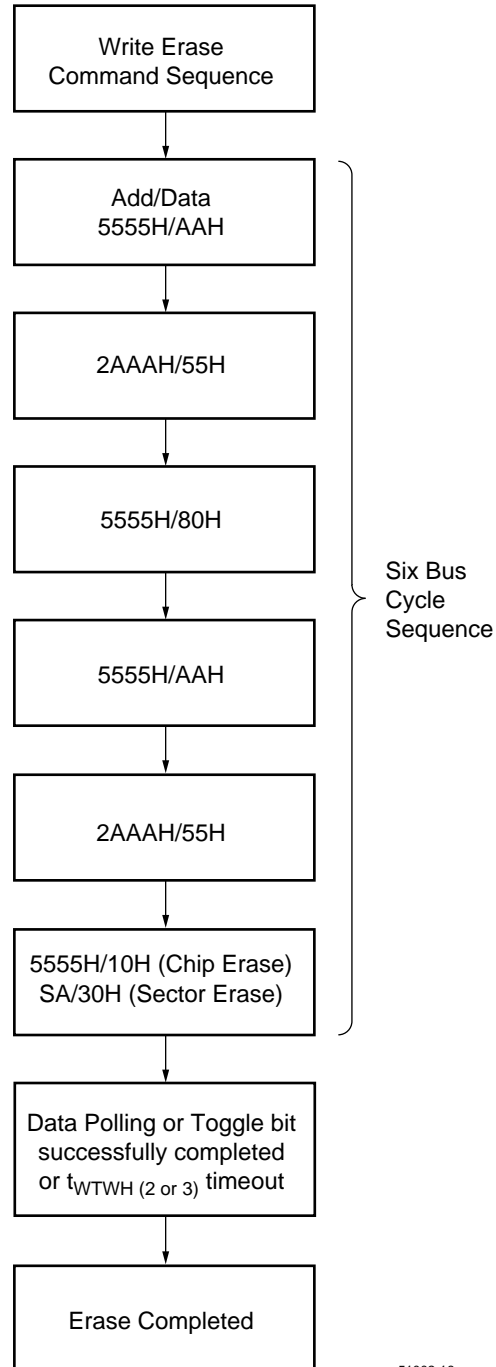

51002-16



DATA Polling Algorithm

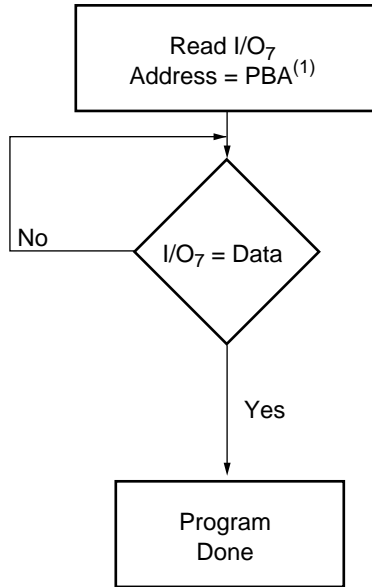

Toggle Bit Algorithm

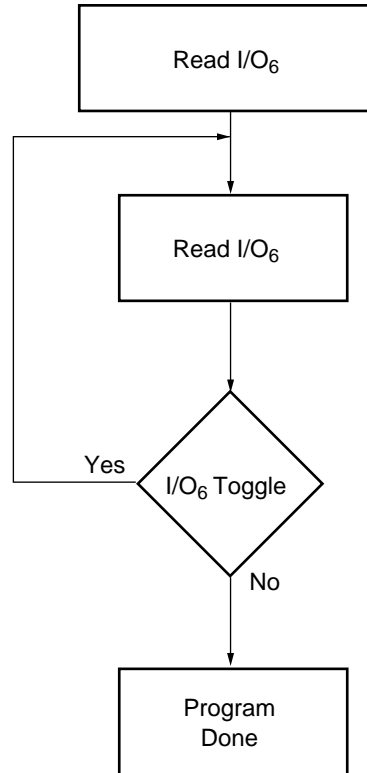

51002-17

NOTE:

1. PBA: The byte address to be programmed.



2 MEGABIT (262,144 x 8 BIT)
5 VOLT CMOS FLASH MEMORY

Package Diagrams

32-pin Plastic DIP

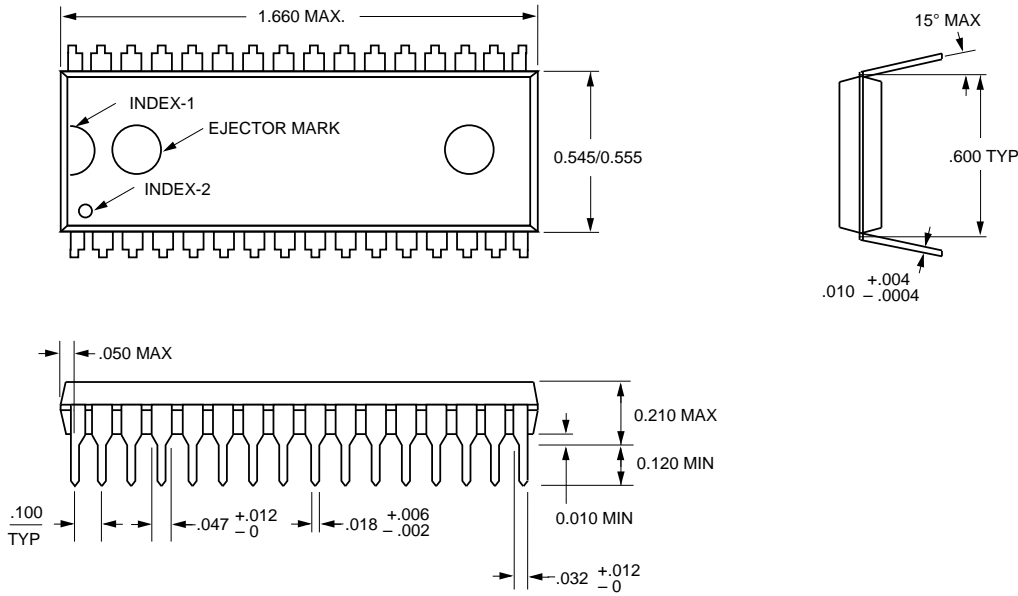

32-pin PLCC

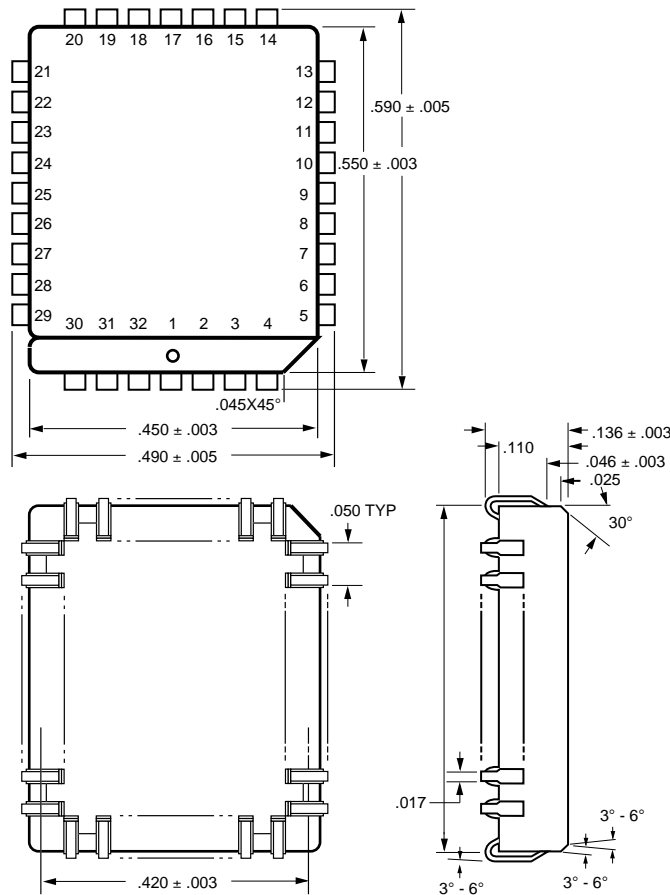



2 MEGABIT (262,144 x 8 BIT)
5 VOLT CMOS FLASH MEMORY

32-pin TSOP-I

Units in inches

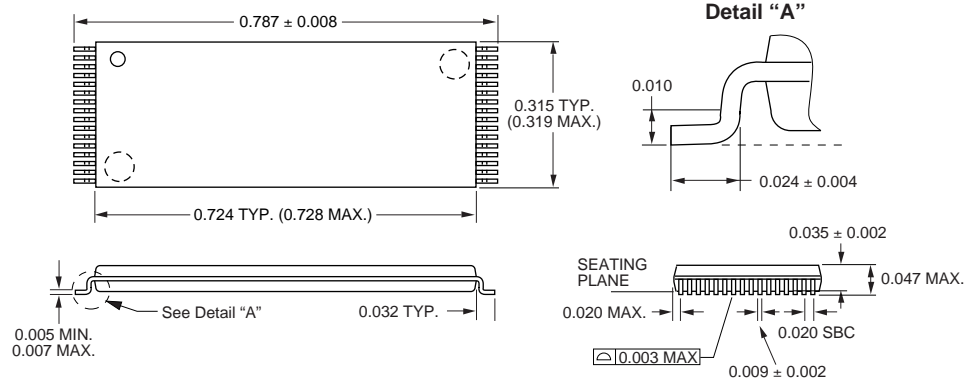



Sales Office :

4th Floor, No. 1, Creation Rd. 1,

Science-Based Industrial Park,

Hsinchu, Taiwan 30077

Tel : 886-3-5792988

Fax : 886-3-5792960

Note :

1. Publication date : November 1998 Rev. A , May 2002 Rev. B

2. All data and specification are subject changed with Program

(Erase/Program) Cycle as below description :

a. Chip erase time : 2.0 sec → 3.0 sec maximum.

b. Byte program time : 20 usec → 35 usec maximum