

S29GL-M MirrorBit™ Flash Family **S29GL256M, S29GL128M, S29GL064M,** **S29GL032M**



256 Megabit, 128 Megabit, 64 Megabit, and 32 Megabit
3.0 Volt-only Page Mode Flash Memory Featuring
0.23 μ m MirrorBit Process Technology

Data Sheet

For new designs, S29GL032A, S29GL064A, S29GL128N, and S29GL256N supersede S29GL032M, S29GL064M, S29GL128M, and S29GL256M, respectively. These are factory-recommended product migrations. Please refer to the S29GL-A and S29GL-N data sheets for specifications and ordering information.

Notice to Readers: This document states the current technical specifications regarding the Spansion product(s) described herein. Spansion LLC deems the products to have been in sufficient production volume such that subsequent versions of this document are not expected to change. However, typographical or specification corrections, or modifications to the valid combinations offered may occur.

Notice On Data Sheet Designations

Spansion LLC issues data sheets with Advance Information or Preliminary designations to advise readers of product information or intended specifications throughout the product life cycle, including development, qualification, initial production, and full production. In all cases, however, readers are encouraged to verify that they have the latest information before finalizing their design. The following descriptions of Spansion data sheet designations are presented here to highlight their presence and definitions.

Advance Information

The Advance Information designation indicates that Spansion LLC is developing one or more specific products, but has not committed any design to production. Information presented in a document with this designation is likely to change, and in some cases, development on the product may discontinue. Spansion LLC therefore places the following conditions upon Advance Information content:

“This document contains information on one or more products under development at Spansion LLC. The information is intended to help you evaluate this product. Do not design in this product without contacting the factory. Spansion LLC reserves the right to change or discontinue work on this proposed product without notice.”

Preliminary

The Preliminary designation indicates that the product development has progressed such that a commitment to production has taken place. This designation covers several aspects of the product life cycle, including product qualification, initial production, and the subsequent phases in the manufacturing process that occur before full production is achieved. Changes to the technical specifications presented in a Preliminary document should be expected while keeping these aspects of production under consideration. Spansion places the following conditions upon Preliminary content:

“This document states the current technical specifications regarding the Spansion product(s) described herein. The Preliminary status of this document indicates that product qualification has been completed, and that initial production has begun. Due to the phases of the manufacturing process that require maintaining efficiency and quality, this document may be revised by subsequent versions or modifications due to changes in technical specifications.”

Combination

Some data sheets will contain a combination of products with different designations (Advance Information, Preliminary, or Full Production). This type of document will distinguish these products and their designations wherever necessary, typically on the first page, the ordering information page, and pages with DC Characteristics table and AC Erase and Program table (in the table notes). The disclaimer on the first page refers the reader to the notice on this page.

Full Production (No Designation on Document)

When a product has been in production for a period of time such that no changes or only nominal changes are expected, the Preliminary designation is removed from the data sheet. Nominal changes may include those affecting the number of ordering part numbers available, such as the addition or deletion of a speed option, temperature range, package type, or V_{IO} range. Changes may also include those needed to clarify a description or to correct a typographical error or incorrect specification. Spansion LLC applies the following conditions to documents in this category:

“This document states the current technical specifications regarding the Spansion product(s) described herein. Spansion LLC deems the products to have been in sufficient production volume such that subsequent versions of this document are not expected to change. However, typographical or specification corrections, or modifications to the valid combinations offered may occur.”

Questions regarding these document designations may be directed to your local AMD or Fujitsu sales office.

S29GL-M MirrorBit™ Flash Family

S29GL256M, S29GL128M, S29GL064M, S29GL032M

256 Megabit, 128 Megabit, 64 Megabit, and 32 Megabit,
3.0 Volt-only Page Mode Flash Memory Featuring
0.23 µm MirrorBit Process Technology



Data Sheet

For new designs, S29GL032A, S29GL064A, S29GL128N, and S29GL256N supersede S29GL032M, S29GL064M, S29GL128M, and S29GL256M, respectively. These are factory-recommended product migrations. Please refer to the S29GL-A and S29GL-N data sheets for specifications and ordering information.

Distinctive Characteristics

Architectural Advantages

- **Single power supply operation**
 - 3 volt read, erase, and program operations
- **Manufactured on 0.23 µm MirrorBit process technology**
- **Secured Silicon Sector region**
 - 128-word/256-byte sector for permanent, secure identification through an 8-word/16-byte random Electronic Serial Number, accessible through a command sequence
 - May be programmed and locked at the factory or by the customer
- **Flexible sector architecture**
 - 256 Mb: 512 32-Kword (64 Kbyte) sectors
 - 128 Mb: 256 32-Kword (64 Kbyte) sectors
 - 64 Mb (uniform sector models): 128 32-Kword (64-Kbyte) sectors or 128 32 Kword sectors
 - 64 Mb (boot sector models): 127 32-Kword (64-Kbyte) sectors + 8 4Kword (8Kbyte) boot sectors
 - 32 Mb (uniform sector models): 64 32-Kword (64-Kbyte) sectors of 64 32-Kword sectors
 - 32 Mb (boot sector models): 63 32-Kword (64 Kbyte) sectors + 8 4-Kword (8-Kbyte) boot sectors
- **Compatibility with JEDEC standards**
 - Provides pinout and software compatibility for single-power supply flash, and superior inadvertent write protection
- **100,000 erase cycles typical per sector**
- **20-year data retention typical**

Performance Characteristics

- **High performance**
 - 90 ns access time (128 Mb, 64 Mb, 32 Mb), 100 ns access time (256 Mb)
 - 4-word/8-byte page read buffer
 - 25 ns page read times (128 Mb, 64 Mb, 32 Mb)
 - 30 ns page read times (256 Mb)
 - 16-word/32-byte write buffer
 - 16-word/32-byte write buffer reduces overall programming time for multiple-word updates

- **Low power consumption (typical values at 3.0 V, 5 MHz)**
 - 18 mA typical active read current (64 Mb, 32 Mb)
 - 25 mA typical active read current (256 Mb, 128 Mb)
 - 50 mA typical erase/program current
 - 1 µA typical standby mode current
- **Package options**
 - 40-pin TSOP
 - 48-pin TSOP
 - 56-pin TSOP
 - 64-ball Fortified BGA
 - 48-ball fine-pitch BGA
 - 63-ball fine-pitch BGA

Software & Hardware Features

- **Software features**
 - Program Suspend & Resume: read other sectors before programming operation is completed
 - Erase Suspend & Resume: read/program other sectors before an erase operation is completed
 - Data# polling & toggle bits provide status
 - CFI (Common Flash Interface) compliant: allows host system to identify and accommodate multiple flash devices
 - Unlock Bypass Program command reduces overall multiple-word programming time
- **Hardware features**
 - Sector Group Protection: hardware-level method of preventing write operations within a sector group
 - Temporary Sector Unprotect: V_{IP}-level method of charging code in locked sectors
 - WP#/ACC input accelerates programming time (when high voltage is applied) for greater throughput during system production. Protects first or last sector regardless of sector protection settings on uniform sector models
 - Hardware reset input (RESET#) resets device
 - Ready/Busy# output (RY/BY#) detects program or erase cycle completion

General Description

The S29GL256/128/064/032M family of devices are 3.0 V single power Flash memory manufactured using 0.23 μm MirrorBit technology. The S29GL256M is a 256 Mbit, organized as 16,777,216 words or 33,554,432 bytes. The S29GL128M is a 128 Mbit, organized as 8,388,608 words or 16,777,216 bytes. The S29GL064M is a 64 Mbit, organized as 4,194,304 words or 8,388,608 bytes. The S29GL032M is a 32 Mbit, organized as 2,097,152 words or 4,194,304 bytes. Depending on the model number, the devices have an 8-bit wide data bus only, 16-bit wide data bus only, or a 16-bit wide data bus that can also function as an 8-bit wide data bus by using the BYTE# input. The devices can be programmed either in the host system or in standard EPROM programmers.

Access times as fast as 90 ns (S29GL128M, S29GL064M, S29GL032M) or 100 ns (S29GL256M) are available. Note that each access time has a specific operating voltage range (V_{CC}) as specified in [Product Selector Guide](#) and [Ordering Information](#). Package offerings include 40-pin TSOP, 48-pin TSOP, 56-pin TSOP, 48-ball fine-pitch BGA, 63-ball fine-pitch BGA and 64-ball Fortified BGA, depending on model number. Each device has separate chip enable (CE#), write enable (WE#) and output enable (OE#) controls.

Each device requires only a **single 3.0 volt power supply** for both read and write functions. In addition to a V_{CC} input, a high-voltage **accelerated program (ACC)** feature provides shorter programming times through increased current on the WP#/ACC input. This feature is intended to facilitate factory throughput during system production, but may also be used in the field if desired.

The device is entirely command set compatible with the **JEDEC single-power-supply Flash standard**. Commands are written to the device using standard microprocessor write timing. Write cycles also internally latch addresses and data needed for the programming and erase operations.

The **sector erase architecture** allows memory sectors to be erased and reprogrammed without affecting the data contents of other sectors. The device is fully erased when shipped from the factory.

Device programming and erasure are initiated through command sequences. Once a program or erase operation starts, the host system need only poll the DQ7 (Data# Polling) or DQ6 (toggle) **status bits** or monitor the **Ready/Busy# (RY/BY#)** output to determine whether the operation is complete. To facilitate programming, an **Unlock Bypass** mode reduces command sequence overhead by requiring only two write cycles to program data instead of four.

Hardware data protection measures include a low V_{CC} detector that automatically inhibits write operations during power transitions. The hardware sector protection feature disables both program and erase operations in any combination of sectors of memory. This can be achieved in-system or via programming equipment.

The **Erase Suspend/Erase Resume** feature allows the host system to pause an erase operation in a given sector to read or program any other sector and then complete the erase operation. The **Program Suspend/Program Resume** feature enables the host system to pause a program operation in a given sector to read any other sector and then complete the program operation.

The **hardware RESET# pin** terminates any operation in progress and resets the device, after which it is then ready for a new operation. The RESET# pin may be tied to the system reset circuitry. A system reset would thus also reset the device, enabling the host system to read boot-up firmware from the Flash memory device.

The device reduces power consumption in the **standby mode** when it detects specific voltage levels on CE# and RESET#, or when addresses are stable for a specified period of time.

The **Write Protect (WP#)** feature protects the first or last sector by asserting a logic low on the WP#/ACC pin or WP# pin, depending on model number. The protected sector is still protected even during accelerated programming.

The **Secured Silicon Sector** provides a 128-word/256-byte area for code or data that can be permanently protected. Once this sector is protected, no further changes within the sector can occur.

Spansion MirrorBit flash technology combines years of Flash memory manufacturing experience to produce the highest levels of quality, reliability and cost effectiveness. The device electrically erases all bits within a sector simultaneously via hot-hole assisted erase. The data is programmed using hot electron injection.

Table of Contents

Distinctive Characteristics	1	Table 24. S29GL064M (Models R1, R2, R8, R9) Sector Group Protection/Unprotection Addresses	45
General Description	2	Table 25. S29GL064M (Model R3) Sector Group Protection/Unprotection Address Table	45
Product Selector Guide	6	Table 27. S29GL064M (Model R5) Sector Group Protection/Unprotection Addresses	46
S29GL256M, S29GL128M, S29GL064M, and S29GL032M	6	Table 28. S29GL064M (Models R6, R7) Sector Group Protection/Unprotection Address	46
Block Diagram	7	Table 29. S29GL128M Sector Group Protection/Unprotection Addresses	46
Connection Diagrams	8	Table 30. S29GL256M Sector Group Protection/Unprotection Addresses	47
For S29GL064M (model R0) only.	13	Temporary Sector Group Unprotect	48
Pin Description	16	Figure 1. Temporary Sector Group Unprotect Operation	48
Logic Symbols	17	Figure 2. In-System Sector Group Protect/Unprotect Algorithms	49
S29GL064M (Models R1, R2, R8, R9)	17	Secured Silicon Sector Flash Memory Region	50
S29GL064M (Models R3, R4)	17	Write Protect (WP#)	51
S29GL064M (Model R5)	18	Hardware Data Protection	51
S29GL064M (Model R6, R7)	18	Low VCC Write Inhibit	51
S29GL128M	18	Write Pulse “Glitch” Protection	51
Ordering Information-S29GL032M	19	Logical Inhibit	51
S29GL032M Standard Products	19	Power-Up Write Inhibit	51
Table 1. S29GL032M Ordering Options	20	Common Flash Memory Interface (CFI)	52
Ordering Information-S29GL064M	21	Table 31. CFI Query Identification String	52
S29GL064M Standard Products	21	Table 32. System Interface String	52
Table 2. S29GL064M Ordering Options	22	Table 33. Device Geometry Definition	53
Ordering Information-S29GL128M	23	Table 34. Primary Vendor-Specific Extended Query	53
Table 3. S29GL128M Ordering Options	24	Command Definitions	54
Ordering Information-S29GL256M	25	Reading Array Data	54
Table 4. S29GL256M Ordering Options	25	Reset Command	54
Device Bus Operations	26	Autoselect Command Sequence	55
Table 5. Device Bus Operations	26	Enter/Exit Secured Silicon Sector Command Sequence	55
Word/Byte Configuration	26	Word Program Command Sequence	55
Requirements for Reading Array Data	26	Unlock Bypass Command Sequence	56
Page Mode Read	27	Write Buffer Programming	56
Writing Commands/Command Sequences	27	Accelerated Program	57
Write Buffer	27	Figure 3. Write Buffer Programming Operation	58
Accelerated Program Operation	27	Figure 4. Program Operation	59
Autoselect Functions	28	Program Suspend/Program Resume Command Sequence	59
Standby Mode	28	Figure 5. Program Suspend/Program Resume	60
Automatic Sleep Mode	28	Chip Erase Command Sequence	60
RESET#: Hardware Reset Pin	28	Sector Erase Command Sequence	61
Output Disable Mode	29	Figure 6. Erase Operation	62
Table 6. S29GL032M (Model R0) Sector Addresses	29	Erase Suspend/Erase Resume Commands	62
Table 7. S29GL032M (Models R1, R2) Sector Addresses	29	Command Definitions	64
Table 8. S29GL032M (Models R3, R5) Top Boot Sector Addresses	30	Table 35. Command Definitions(x16 Mode, BYTE# = V _{IH})	64
Table 9. S29GL032M (Models R4, R6) Bottom Boot Sector Addresses	30	Table 36. Command Definitions (x8 Mode, BYTE# = V _{IL})	65
Table 11. S29GL064M (Models R1, R2, R8, R9) Sector Addresses	32	Write Operation Status	66
Table 14. S29GL064M (Model R5) Sector Addresses	35	DQ7: Data# Polling	66
Table 17. S29GL256M Sector Address Table	39	Figure 7. Data# Polling Algorithm	67
Autoselect Mode	43	RY/BY#: Ready/Busy#	67
Table 18. Autoselect Codes, (High Voltage Method)	43	DQ6: Toggle Bit I	67
Table 19. S29GL032M (Model R0) Sector Group Protection/Unprotection Addresses	44	Figure 8. Toggle Bit Algorithm	69
Table 20. S29GL032M (Models R1, R2) Sector Group Protection/Unprotection Addresses	44	DQ2: Toggle Bit II	69
Table 21. S29GL032M (Models R3, R5) Sector Group Protection/Unprotection Address Table	44	DQ5: Exceeded Timing Limits	70
Table 22. S29GL032M (Models R4, R6) Sector Group Protection/Unprotection Address Table	45	DQ3: Sector Erase Timer	70
Table 23. S29GL064M (Model R0) Sector Group Protection/Unprotection Address Table	45	DQI: Write-to-Buffer Abort	71
		Table 37. Write Operation Status	71
		Absolute Maximum Ratings	72

Figure 9. Maximum Negative Overshoot Waveform	72	Figure 23. Sector Group Protect and Unprotect Timing Diagram	86
Figure 10. Maximum Positive Overshoot Waveform.....	72	Alternate CE# Controlled Erase and Program Operations-S29GL064M	88
DC Characteristics	73	88
CMOS Compatible	73	Alternate CE# Controlled Erase and Program Operations-S29GL032M	88
Test Conditions	74	88
Figure 11. Test Setup	74	Figure 24. Alternate CE# Controlled Write (Erase/ Program) Operation Timings.....	89
Table 38. Test Specifications	74	Erase and Programming Performance	90
Key to Switching Waveforms	74	TSOP Pin and BGA Package Capacitance	91
Figure 12. Input Waveforms and Measurement Levels.....	74	Physical Dimensions	92
AC Characteristics	75	TS040—40-Pin Standard Thin Small Outline Package	92
Read-Only Operations-S29GL256M Only	75	TSR040—40-Pin Standard/Reverse Thin Small Outline Package	
Read-Only Operations-S29GL128M only	75	(TSOP)	93
Read-Only Operations-S29GL064M Only	75	TS048—48-Pin Standard/Reverse Thin Small Outline Package	
Read-Only Operations-S29GL032M only	76	(TSOP)	94
Figure 13. Read Operation Timings	76	TSR048—48-Pin Standard/Reverse Thin Small Outline Package	
Figure 14. Page Read Timings	77	(TSOP)	95
Hardware Reset (RESET#)	77	TS056/TSR056—56-Pin Standard/Reverse Thin Small Outline Package	
Figure 15. Reset Timings.....	78	(TSOP)	96
Erase and Program Operations-S29GL256M Only	79	LAA064—64-Ball Fortified Ball Grid Array (FBGA)	97
Erase and Program Operations-S29GL128M Only	80	LAC064—64-Pin 18 x 12 mm Package	98
Erase and Program Operations-S29GL064M Only	81	FBA048—48-Pin 6.15 x 8.15 mm Package	99
Erase and Program Operations-S29GL032M Only	82	FBC048—48-Pin 8 x 9 mm Package	100
Figure 16. Program Operation Timings	83	FBE063—63-Pin 12 x 11 mm Package	101
Figure 17. Accelerated Program Timing Diagram	83	FPT-48P-MI9	102
Figure 18. Chip/Sector Erase Operation Timings.....	84	FPT-56P-M01	102
Figure 19. Data# Polling Timings (During Embedded Algorithms)	84	FBG048—48-Pin 8 x 6 mm Package	103
.....	84	Revision Summary	104
Figure 20. Toggle Bit Timings (During Embedded Algorithms) ..	85		
Figure 21. DQ2 vs. DQ6	85		
Temporary Sector Unprotect	85		
Figure 22. Temporary Sector Group Unprotect Timing Diagram	86		

Product Selector Guide

S29GL256M, S29GL128M, S29GL064M, and S29GL032M

Part Number	S29GL256M		S29GL128M		S29GL064M			S29GL032M		
Speed Option	10	11	90	10	90	10	11	90	10	11
Max. Access Time (ns)	100	110	90	100	90	100	110	90	100	110
Max. CE# Access Time (ns)	100	110	90	100	90	100	110	90	100	110
Max. Page Access Time (ns)	30	30	25	30	25	30	30	25	30	30
Max. OE# Access Time (ns)	30	30	25	30	25	30	30	25	30	30

Block Diagram

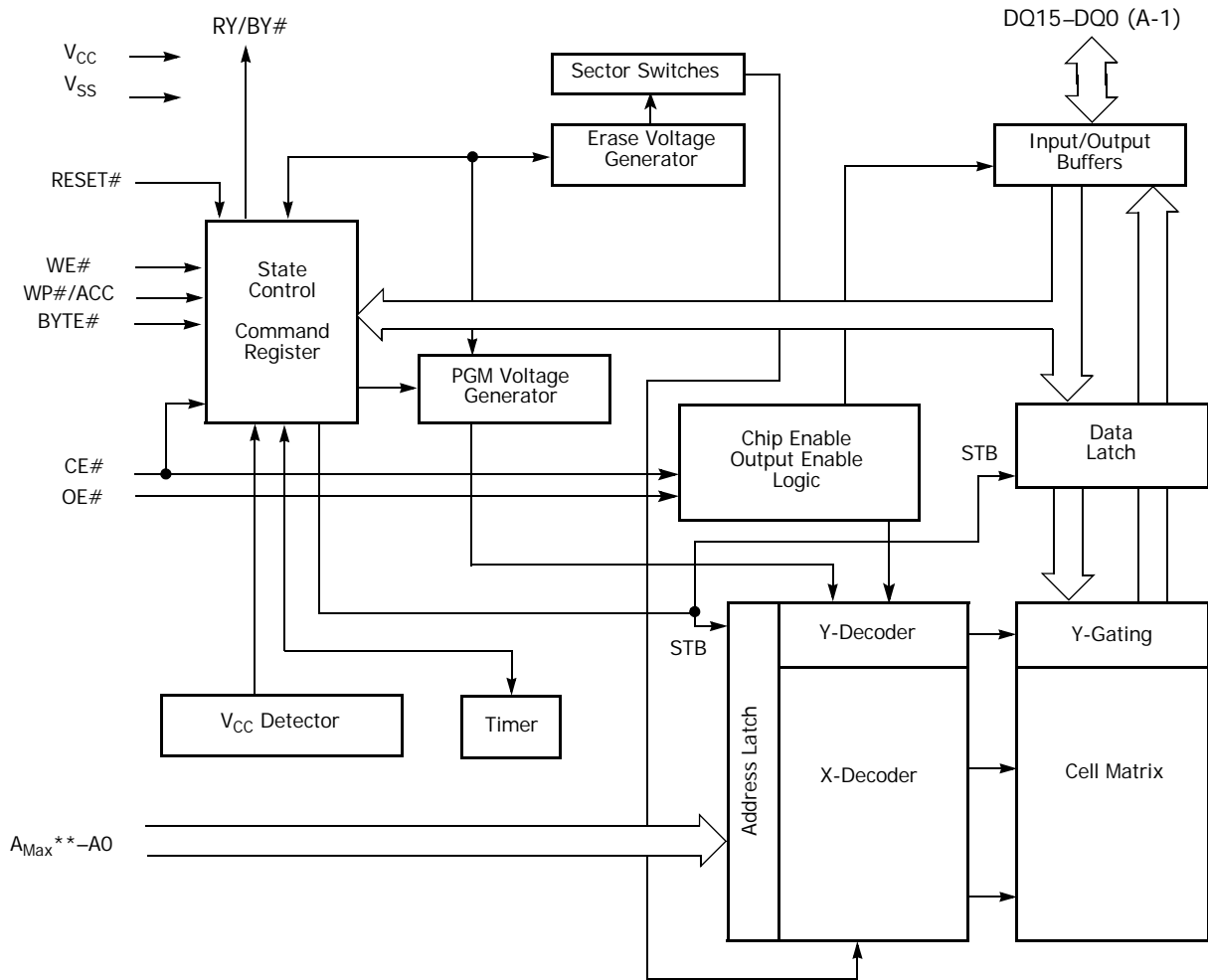

** $A_{Max} GL256M = A23$

$A_{Max} GL128M = A22$

$A_{Max} GL064M = A21$ ($A_{Max} GL064M-00 = A22$)

$A_{Max} GL032M = A20$ ($A_{Max} GL032M-00 = A21$)

Connection Diagrams

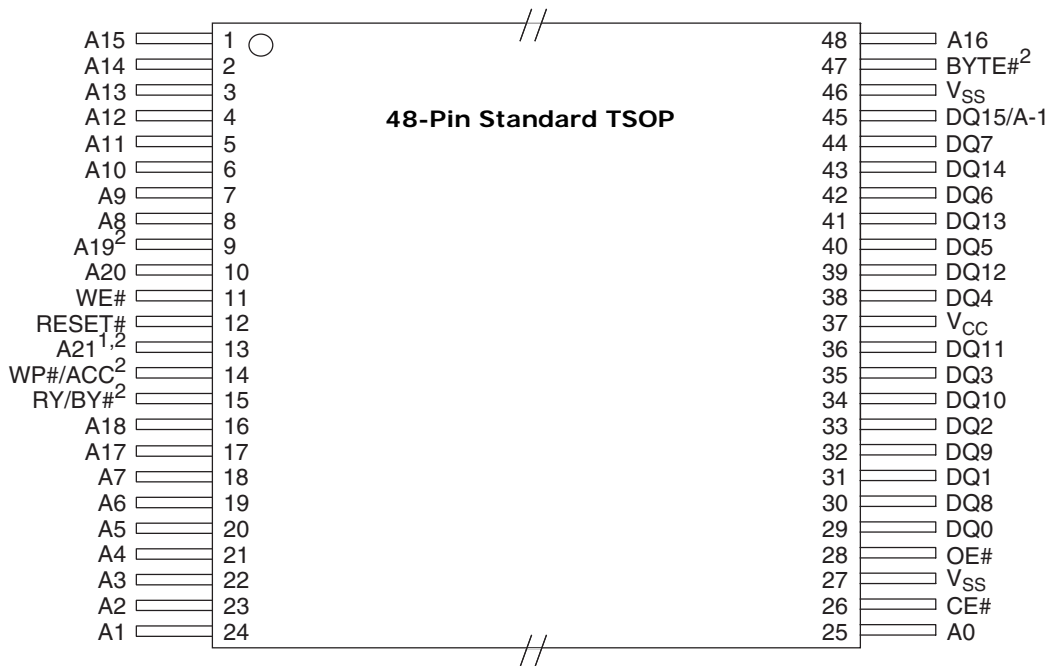
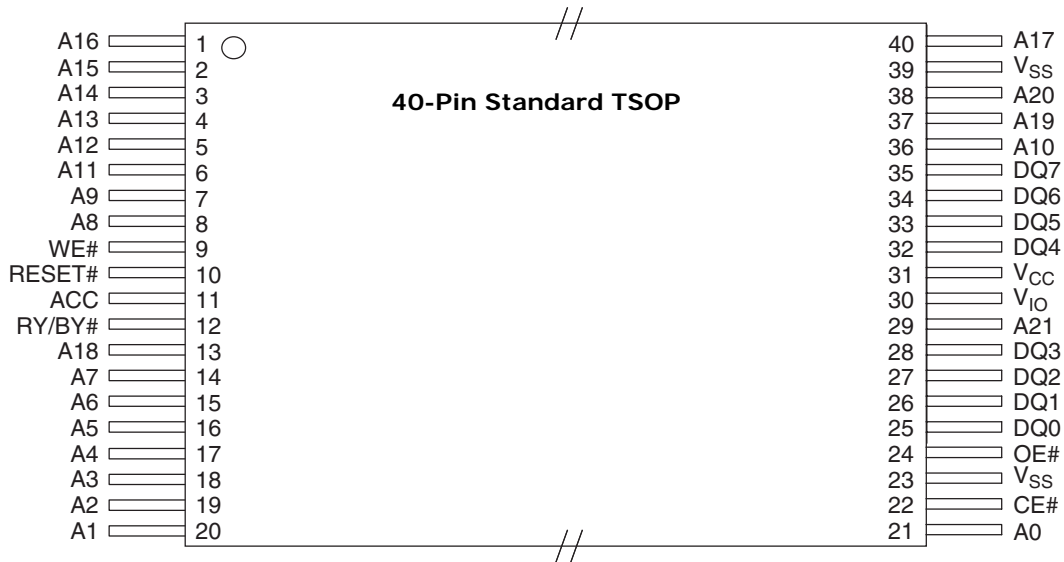

Notes:

1. Pin 13 is NC on S29GL032M.
2. Pin 9 is A21, Pin 13 is ACC, Pin 14 is WP#, Pin 15 is A19, and Pin 47 is V_{IO} on S29GL064M (models R6, R7).

Connection Diagrams

For S29GL064M (model R0) only

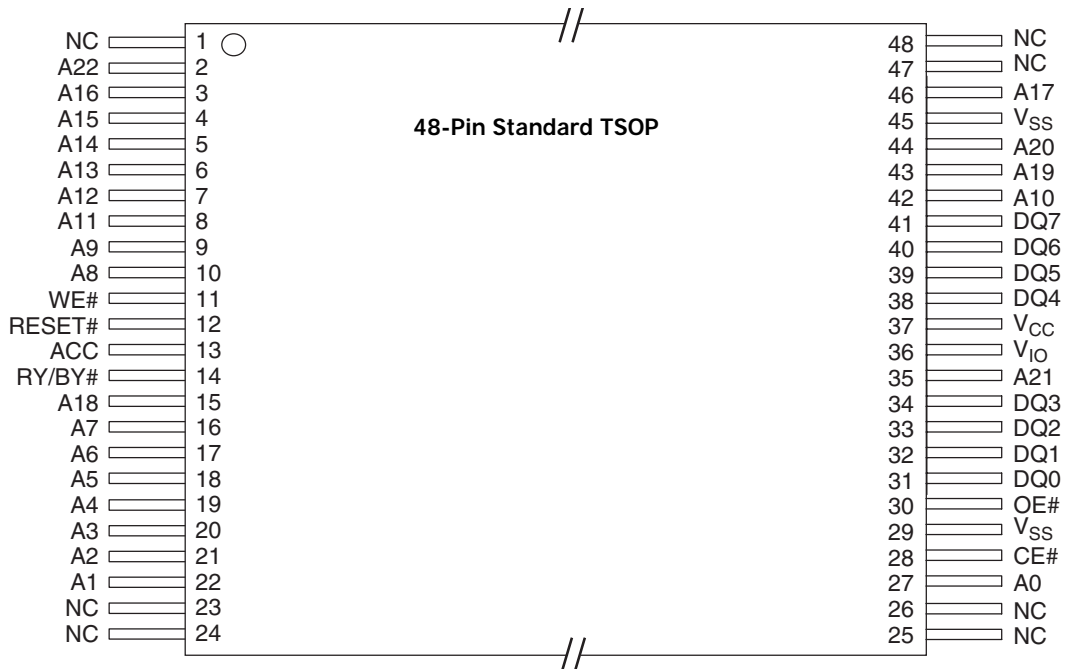

Connection Diagrams

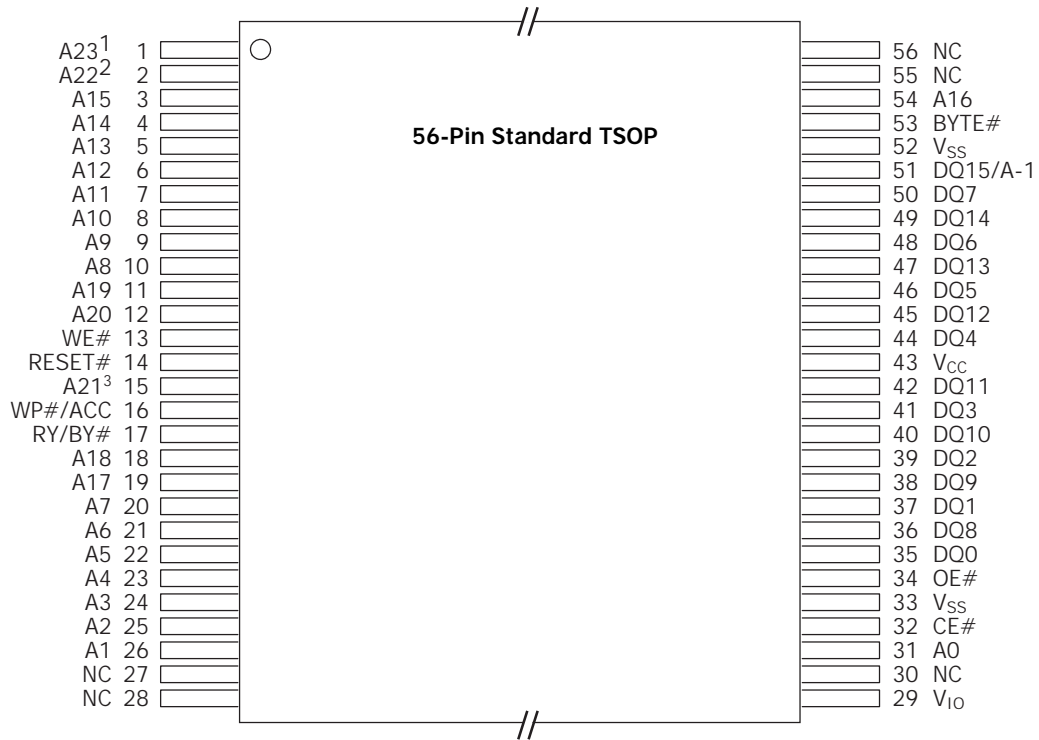

Notes:

1. Pin 1 is NC on S29GL128M, 29GL064M, and S29GL032M.
2. Pin 2 is NC on S29GL064M, and S29GL032M.
3. Pin 15 is NC on S29GL032M.

Connection Diagrams

64-ball Fortified BGA
Top View, Balls Facing Down

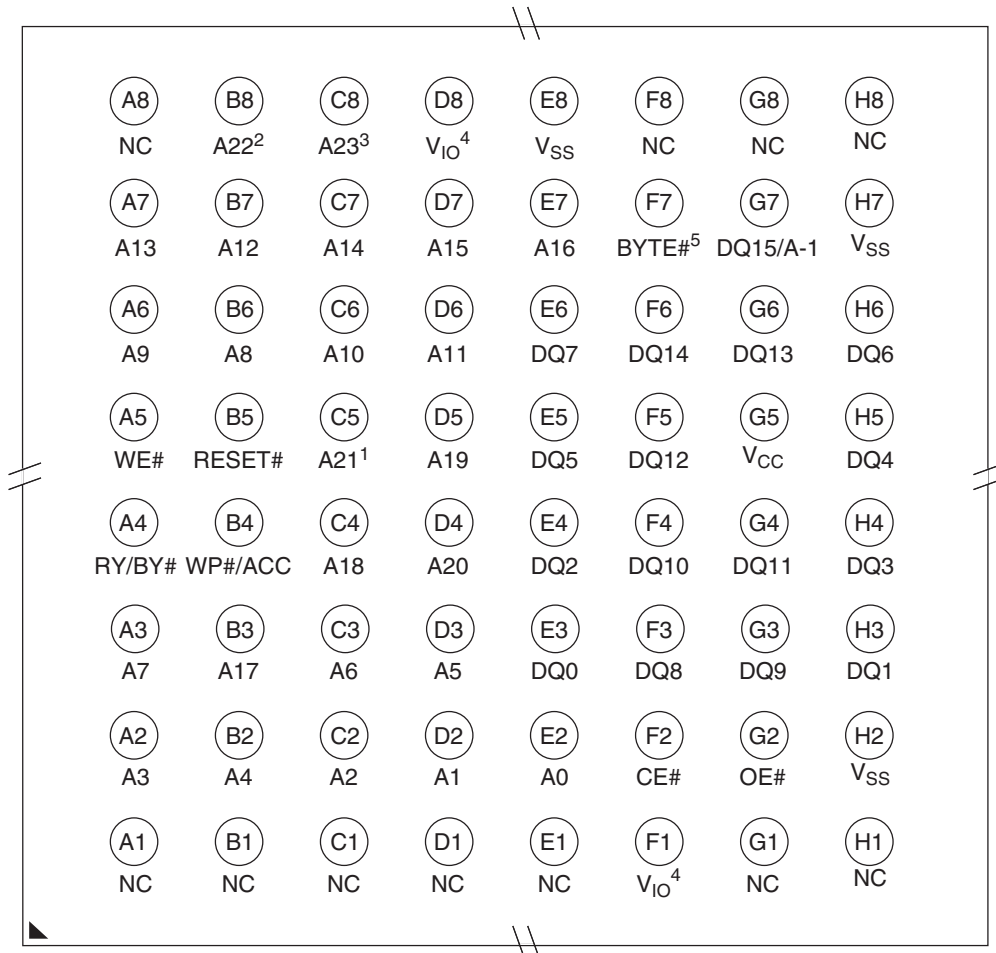

Notes:

1. Ball C5 is NC on S29GL032M.
2. Ball B8 is NC on S29GL064M and S29GL032M.
3. Ball C8 is NC on S29GL128M, S29GL064M and S29GL032M.
4. Ball D8 and Ball F1 are NC on S29GL064M (models R3, R4) and S29GL032M (models R3, R4, R5, R6).
5. Ball F7 is NC on S29GL064M (model R5).

Special Package Handling Instructions

Special handling is required for Flash Memory products in moulded packages (TSOP and BGA). The package and/or data integrity may be compromised if the package body is exposed to temperatures above 150°C for prolonged periods of time.

Connection Diagrams

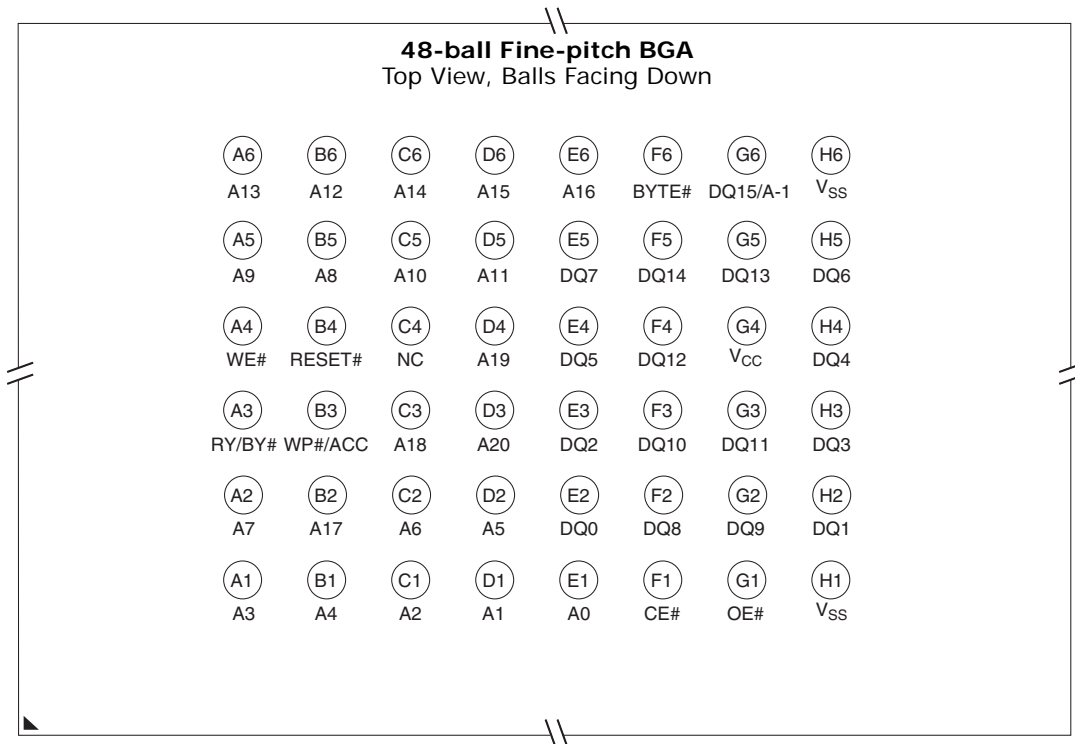

Special Package Handling Instructions

Special handling is required for Flash Memory products in molded packages (TSOP and BGA). The package and/or data integrity may be compromised if the package body is exposed to temperatures above 150°C for prolonged periods of time.

Connection Diagrams

For S29GL032M (model R0) only.

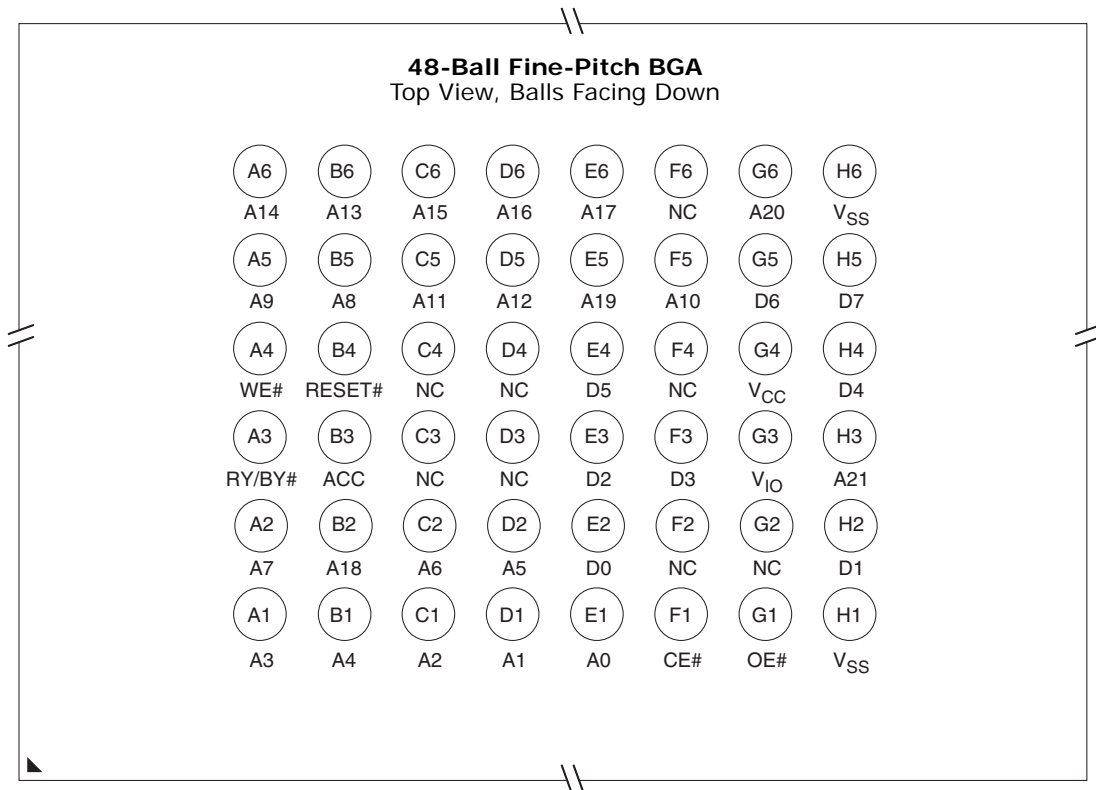

Special Package Handling Instructions

Special handling is required for Flash Memory products in molded packages (TSOP and BGA). The package and/or data integrity may be compromised if the package body is exposed to temperatures above 150°C for prolonged periods of time.

Pin Description

A23–A0	=	24 Address inputs
A22–A0	=	23 Address inputs
A21–A0	=	22 Address inputs
A20–A0	=	21 Address inputs
DQ7–DQ0	=	8 Data inputs/outputs
DQ14–DQ0	=	15 Data inputs/outputs
DQ15/A-1	=	DQ15 (Data input/output, word mode), A-1 (LSB Address input, byte mode)
CE#	=	Chip Enable input
OE#	=	Output Enable input
WE#	=	Write Enable input
WP#/ACC	=	Hardware Write Protect input/Programming Acceleration input
ACC	=	Acceleration input
WP#	=	Hardware Write Protect input
RESET#	=	Hardware Reset Pin input
RY/BY#	=	Ready/Busy output
BYTE#	=	Selects 8-bit or 16-bit mode
V _{CC}	=	3.0 volt-only single power supply (see Product Selector Guide for speed options and voltage supply tolerances)
V _{SS}	=	Device Ground
NC	=	Pin Not Connected Internally
V _{IO}	=	Output Buffer Power

Logic Symbols

S29GL032M (Model R0)

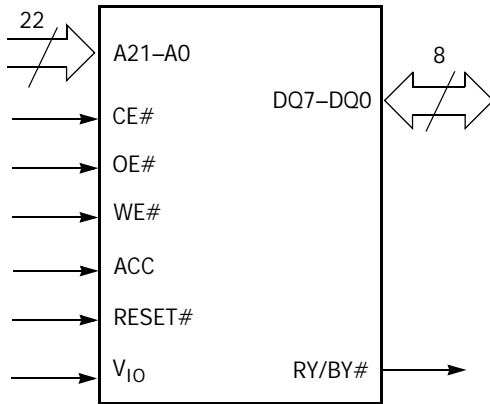

S29GL032M (Models RI, R2)

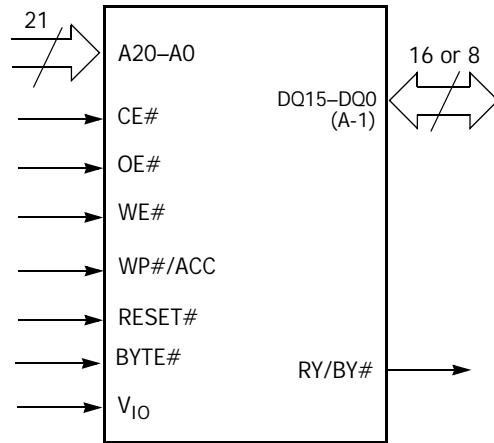

S29GL032M (Models R3, R4, R5, R6)

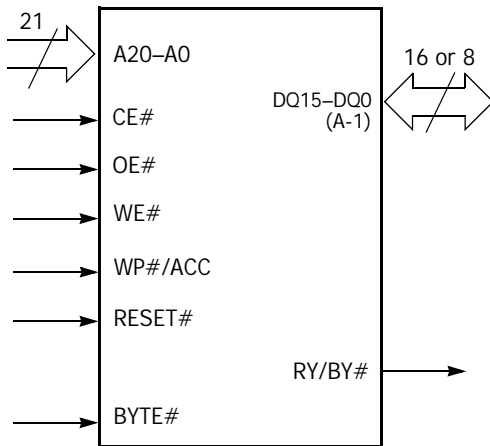

S29GL064M (Model R0)

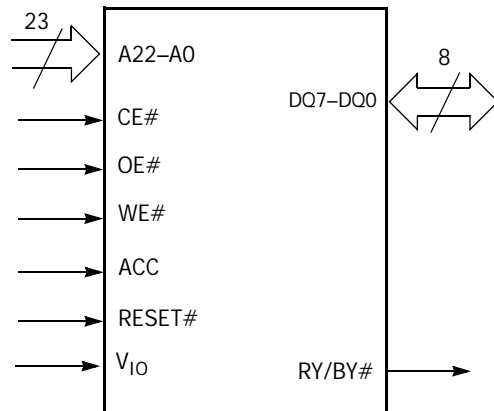

S29GL064M (Models RI, R2, R8, R9)

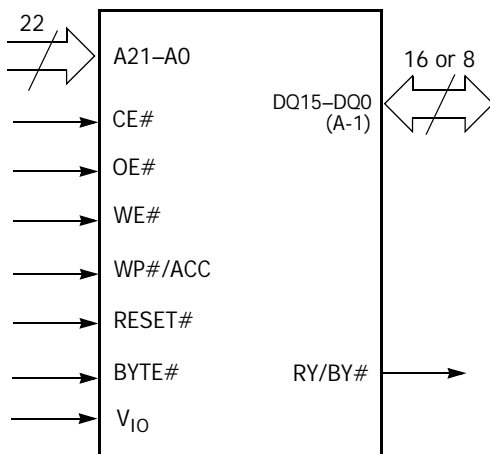

S29GL064M (Models R3, R4)

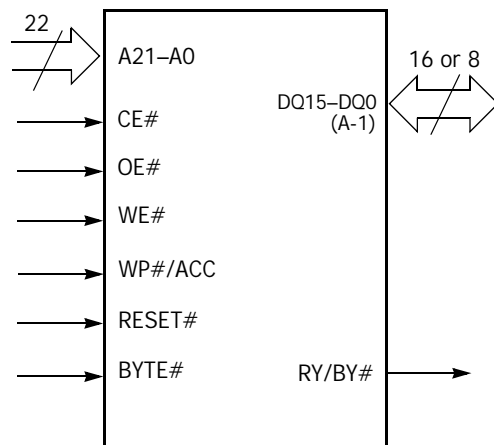

Logic Symbols

S29GL064M (Model R5)

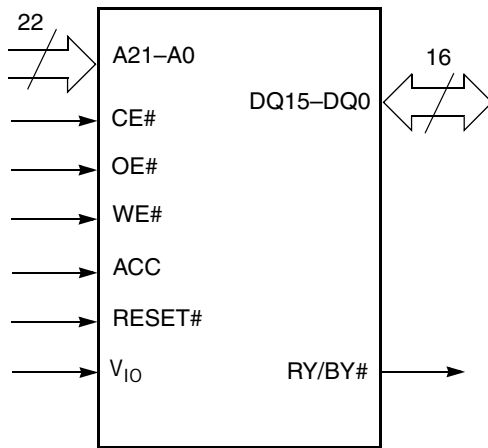

S29GL064M (Model R6, R7)

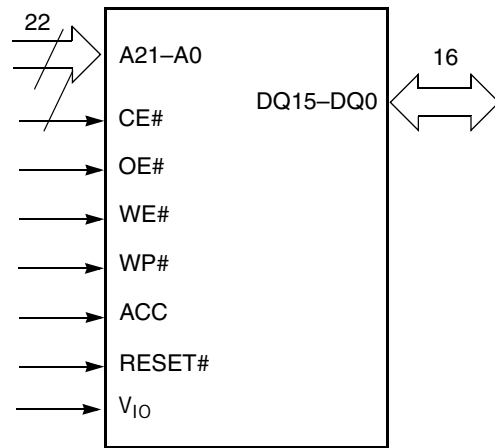

S29GLI28M

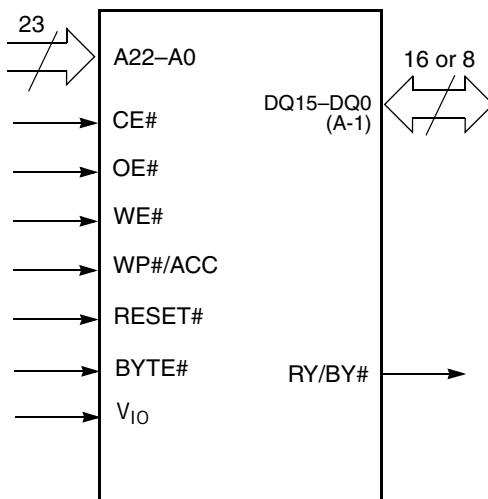

S29GL256M

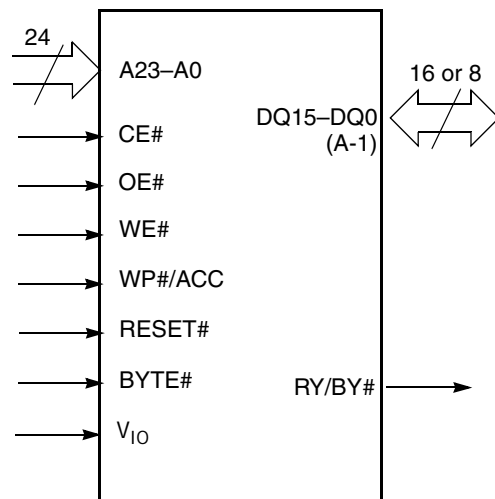

Table I. S29GL032M Ordering Options

S29GL032M Valid Combinations					Package Description (Notes)	
Device Number	Speed Option	Package, Material, & Temperature Range	Model Number	Packing Type		
S29GL032M	90	TAC,TFC	R0	0,2,3 (Note 1)	TS040 (2, 3, 5)	TSOP
		BAC,BFC			FBC048 (4)	Fine-Pitch BGA
		TAC,TFC	R1,R2		TS056 (2, 3, 5)	TSOP
		FAC,FFC			LAA064 (4)	Fortified BGA
		TAC,TFC	R3,R4		TS048 (2, 3, 5)	TSOP
		BAC,BFC			FBC048 (4)	Fine-Pitch BGA
	FAC,FFC	LAA064 (4)			Fortified BGA	
	90, 10, 11	TAI,TFI	R0		TS040 (2, 3, 5)	TSOP
		BAI,BFI			FBC048 (4)	Fine-Pitch BGA
		TAI,TFI	R1,R2		TS056 (2, 3, 5)	TSOP
		FAI,FFI			LAA064 (4)	Fortified BGA
		TAI,TFI	R3,R4		TS048 (2, 3, 5)	TSOP
		BAI,BFI			FBC048 (4)	Fine-Pitch BGA
		FAI,FFI			LAA064 (4)	Fortified BGA
		TBI,TCI			FPT-48P-M19 (3, 6)	TSOP
		BAI,BFI	R5,R6		FBG048 (4)	Fine-Pitch BGA

Notes:

1. Type 0 is standard. Specify others as required: TSOPs can be packed in Types 0 and 3; BGAs can be packed in Types 0, 2, or 3.
2. This package is recommended for new designs using TSOPs.
3. TSOP package marking omits packing type designator from the ordering part number.
4. BGA package marking omits leading "S29" and packing type designator from the ordering part number.
5. 100% Matte Sn is used for Pb-free TSOP plating.
6. SnBi is used for Pb-free TSOP plating.

Valid Combinations

Valid Combinations list configurations planned to be supported in volume for this device. Consult your local sales office to confirm availability of specific valid combinations and to check on newly released combinations.

Ordering Information-S29GL064M

For new designs, S29GL064A supersedes S29GL064M, and is the factory-recommended migration path. Please refer to the S29GL-A Datasheet for specifications and ordering information.

S29GL064M Standard Products

Standard products are available in several packages and operating ranges. The order number (Valid Combination) is formed by a combination of the following:

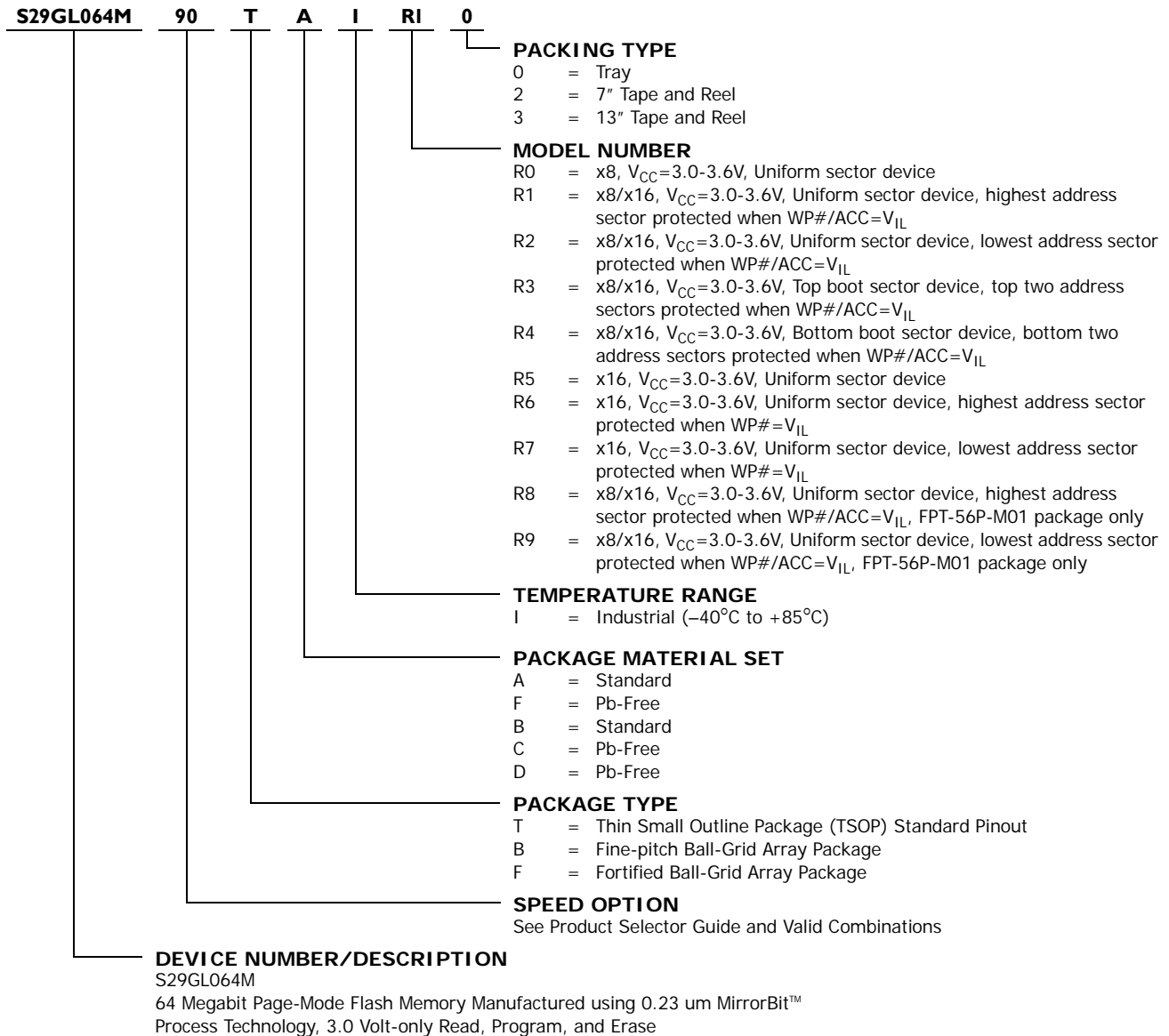

Valid Combinations

Valid Combinations list configurations planned to be supported in volume for this device. Consult your local sales office to confirm availability of specific valid combinations and to check on newly released combinations.

Table 2. S29GL064M Ordering Options

S29GL064M Valid Combinations					Package Description (Notes)	
Device Number	Speed Option	Package, Material, & Temperature Range	Model Number	Packing Type		
S29GL064M	90, 10, 11	TAI, TFI	R0,R3,R4,R6,R7	0,2,3 (Note 1)	TS048 (2, 3, 5)	
			R1,R2		TS056 (2, 3, 5)	
		TBI, TCI	R2,R7		FPT-48P-M19 (3, 6)	
		TAI, TDI	R9		FPT-56P-M01 (3, 6)	
		BAI, BFI	R0,R3,R4,R5		FBE063 (4, 6)	Fine-Pitch BGA
		FAI, FFI	R1,R2,R3,R4,R5		LAA064 (4)	Fortified BGA

Notes:

1. Type 0 is standard. Specify others as required: TSOPs can be packed in Types 0 and 3; BGAs can be packed in Types 0, 2, or 3.
2. This package is recommended for new designs using TSOPs.
3. TSOP package marking omits packing type designator from the ordering part number.
4. BGA package marking omits leading "S29" and packing type designator from the ordering part number.
5. 100% Matte Sn is used for Pb-free TSOP plating.
6. SnBi is used for Pb-free TSOP plating.

Ordering Information-S29GL128M

For new designs, S29GL128N supersedes S29GL128M, and is the factory-recommended migration path. Please refer to the S29GL-N Datasheet for specifications and ordering information.

Standard products are available in several packages and operating ranges. The order number (Valid Combination) is formed by a combination of the following:

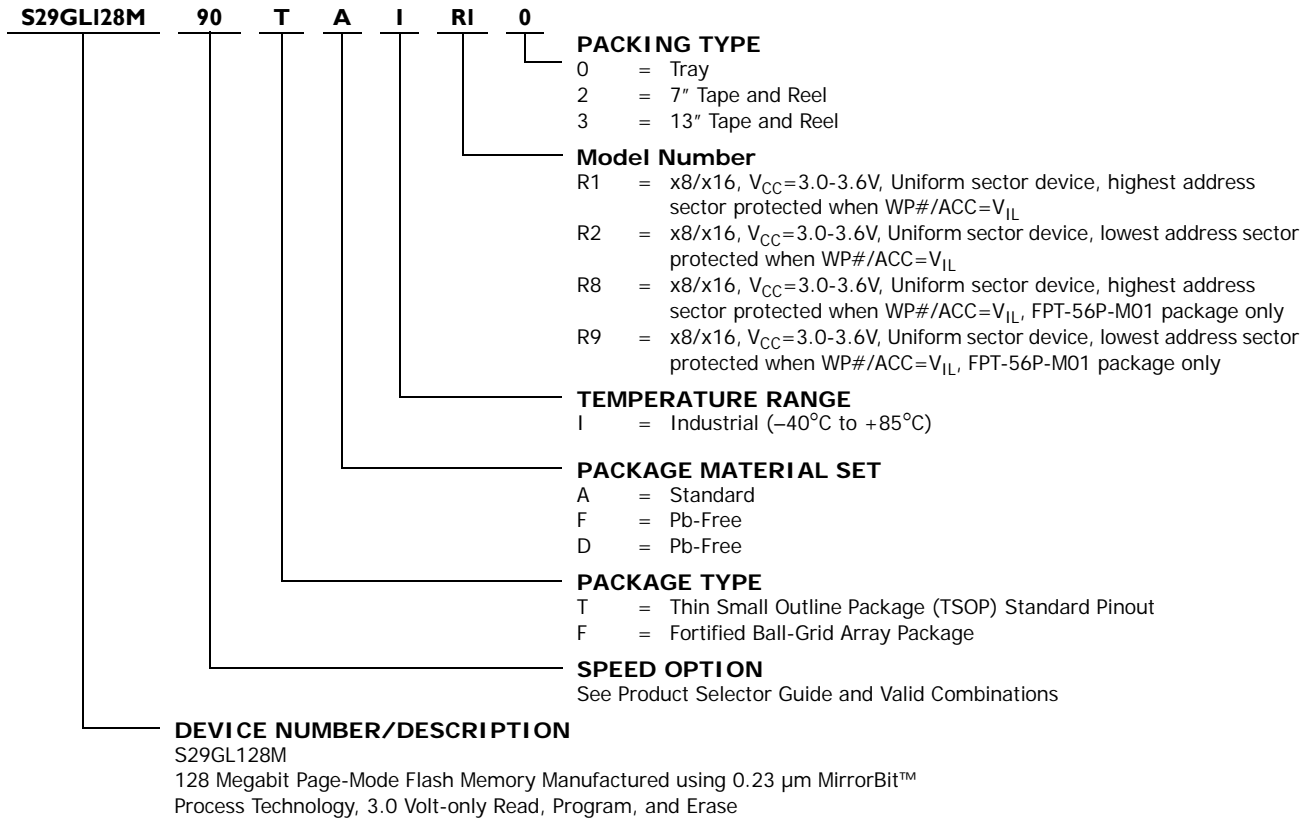

Table 3. S29GL128M Ordering Options

S29GL128M Valid Combinations					Package Descriptions (Notes)	
Base Ordering Part Number	Speed Option	Package Type, Material, & Temperature Range	Model Number	Packing Type		
S29GL128M	90, 10, 11 (Note 7)	TAI, TFI	R1, R2	0, 2, 3 (Note 1)	TS056 (2, 3, 5)	TSOP
		TAI, TDI	R9		FPT-56P-M01 (3, 6)	
		FAI, FFI	R1, R2		LAA064 (4)	

Notes:

1. Type 0 is standard. Specify others as required: TSOPs can be packed in Types 0 and 3; BGAs can be packed in Types 0, 2, or 3.
2. This package is recommended for new designs using TSOPs.
3. TSOP package marking omits packing type designator from the ordering part number.
4. BGA package marking omits leading "S29" and packing type designator from the ordering part number.
5. 100% Matte Sn is used for Pb-free TSOP plating.
6. SnBi is used for Pb-free TSOP plating.
7. Contact your Spansion representative for availability of the 90ns speed option for LAA064.

Valid Combinations

Valid Combinations list configurations planned to be supported in volume for this device. Consult your local sales office to confirm availability of specific valid combinations and to check on newly released combinations.

Ordering Information-S29GL256M

For new designs, S29GL256N supersedes S29GL256M, and is the factory-recommended migration path. Please refer to the S29GL-N Datasheet for specifications and ordering information.

Standard products are available in several packages and operating ranges. The order number (Valid Combination) is formed by a combination of the following:

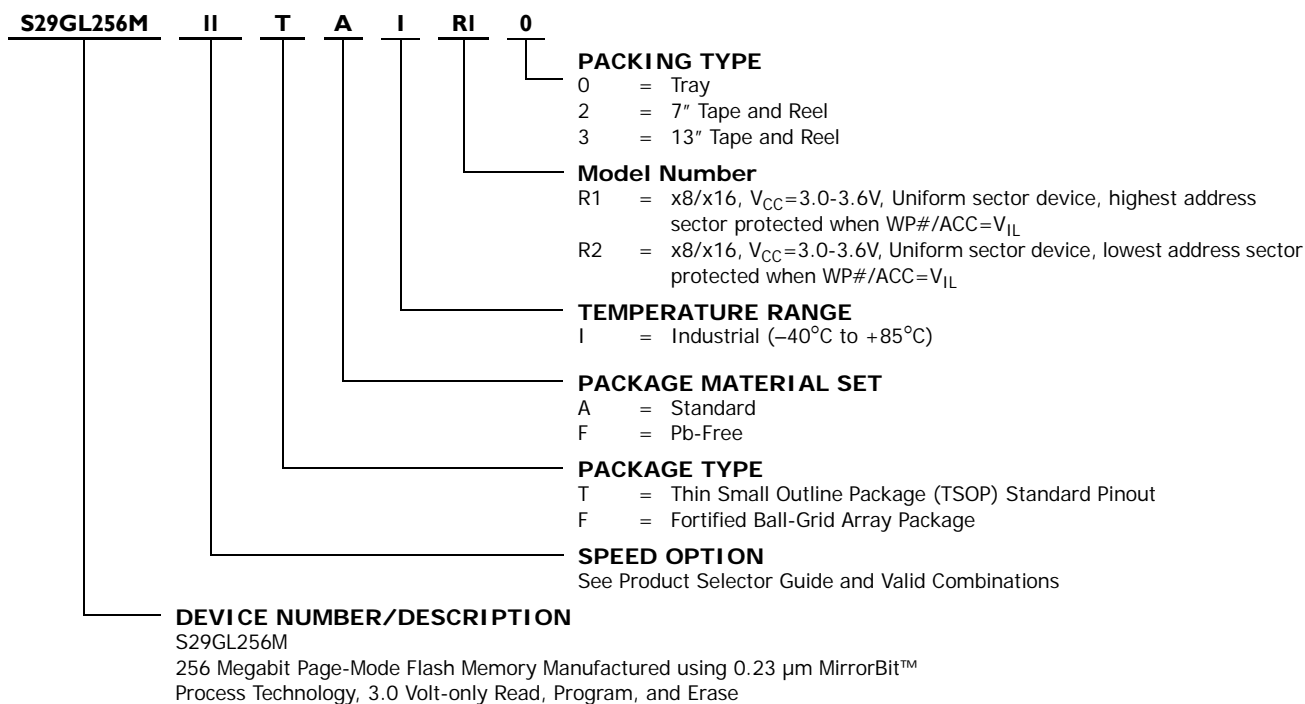

Table 4. S29GL256M Ordering Options

S29GL256M Valid Combinations					Package Description (Notes)	
Device Number	Speed Option	Package, Material, & Temperature Range	Model Number	Packing Type		
S29GL256M	10, 11 (Note 5)	TAI,TFI	R1,R2	0,2,3 (Note 1)	TS056 (2, 3, 4)	TSOP
		FAI,FFI			LAC064 (3)	Fortified BGA

Notes:

- Type 0 is standard. Specify others as required: TSOPs can be packed in Types 0 and 3; BGAs can be packed in Types 0, 2, or 3.
- TSOP package marking omits the packing type designator from the ordering part number.
- BGA package marking omits leading "S29" and packing type designator from the ordering part number.
- 100% Matte Sn is used for Pb-free TSOP plating.
- Contact your Spansion representative for availability of the 100 ns speed option.

Valid Combinations

Valid Combinations list configurations planned to be supported in volume for this device. Consult your local sales office to confirm availability of specific valid combinations and to check on newly released combinations.

Device Bus Operations

This section describes the requirements and use of the device bus operations, which are initiated through the internal command register. The command register itself does not occupy any addressable memory location. The register is a latch used to store the commands, along with the address and data information needed to execute the command. The contents of the register serve as inputs to the internal state machine. The state machine outputs dictate the function of the device. Table 5 lists the device bus operations, the inputs and control levels they require, and the resulting output. The following subsections describe each of these operations in further detail.

Table 5. Device Bus Operations

Operation	CE#	OE#	WE#	RESET#	WP#	ACC	Addresses (Note 1)	DQ0– DQ7	DQ8–DQ15	
									BYTE# = V _{IH}	BYTE# = V _{IL}
Read	L	L	H	H	X	X	A _{IN}	D _{OUT}	D _{OUT}	DQ8–DQ14
Write (Program/Erase)	L	H	L	H	(Note 3)	X	A _{IN}	(Note 4)	(Note 4)	= High-Z,
Accelerated Program	L	H	L	H	(Note 3)	V _{HH}	A _{IN}	(Note 4)	(Note 4)	DQ15 = A-1
Standby	V _{CC} ± 0.3 V	X	X	V _{CC} ± 0.3 V	X	H	X	High-Z	High-Z	High-Z
Output Disable	L	H	H	H	X	X	X	High-Z	High-Z	High-Z
Reset	X	X	X	L	X	X	X	High-Z	High-Z	High-Z
Sector Group Protect (Note 2)	L	H	L	V _{ID}	H	X	SA, A6=L, A3=L, A2=L, A1=H, A0=L	(Note 4)	X	X
Sector Group Unprotect (Note 2)	L	H	L	V _{ID}	H	X	SA, A6=H, A3=L, A2=L, A1=H, A0=L	(Note 4)	X	X
Temporary Sector Group Unprotect	X	X	X	V _{ID}	H	X	A _{IN}	(Note 4)	(Note 4)	High-Z

Legend: L = Logic Low = V_{IL}, H = Logic High = V_{IH}, V_{ID} = 11.5–12.5 V, V_{HH} = 11.5 V – 12.5 V, X = Don't Care, SA = Sector Address, A_{IN} = Address In, D_{IN} = Data In, D_{OUT} = Data Out

Notes:

- Addresses are Amax:A0 in word mode; Amax:A-1 in byte mode. Sector addresses are Amax:A15 in both modes.
- The sector protect and sector unprotect functions may also be implemented via programming equipment. See the "Sector Group Protection and Unprotection" section.
- If WP# = V_{IL}, the first or last sector remains protected (for uniform sector devices), and the two outer boot sectors are protected (for boot sector devices). If WP# = V_{IH}, the first or last sector, or the two outer boot sectors are protected or unprotected as determined by the method described in "Sector Group Protection and Unprotection". All sectors are unprotected when shipped from the factory (The Secured Silicon Sector may be factory protected depending on version ordered.)
- D_{IN} or D_{OUT} as required by command sequence, data polling, or sector protect algorithm (see Figure 2).

Word/Byte Configuration

The BYTE# pin controls whether the device data I/O pins operate in the byte or word configuration. If the BYTE# pin is set at logic '1', the device is in word configuration, DQ0–DQ15 are active and controlled by CE# and OE#.

If the BYTE# pin is set at logic '0', the device is in byte configuration, and only data I/O pins DQ0–DQ7 are active and controlled by CE# and OE#. The data I/O pins DQ8–DQ14 are tri-stated, and the DQ15 pin is used as an input for the LSB (A-1) address function.

Requirements for Reading Array Data

To read array data from the outputs, the system must drive the CE# and OE# pins to V_{IL}. CE# is the power control and selects the device. OE# is the output control and gates array data to the output pins. WE# should remain at V_{IH}.

The internal state machine is set for reading array data upon device power-up, or after a hardware reset. This ensures that no spurious alteration of the memory content occurs during the power transition. No command is necessary in this mode to obtain array data. Standard microprocessor read cycles that assert valid addresses on the device address inputs produce valid data on the device data outputs. The device remains enabled for read access until the command register contents are altered.

See [Reading Array Data](#) for more information. See [AC Characteristics](#) for timing specifications and the timing diagram. See [DC Characteristics](#) for the active current specification on reading array data.

Page Mode Read

The device is capable of fast page mode read and is compatible with the page mode Mask ROM read operation. This mode provides faster read access speed for random locations within a page. The page size of the device is 4 words/8 bytes. The appropriate page is selected by the higher address bits A(max)–A2. Address bits A1–A0 in word mode (A1–A-1 in byte mode) determine the specific word within a page. This is an asynchronous operation; the microprocessor supplies the specific word location.

The random or initial page access is equal to t_{ACC} or t_{CE} and subsequent page read accesses (as long as the locations specified by the microprocessor falls within that page) is equivalent to t_{PACC} . When CE# is deasserted and reasserted for a subsequent access, the access time is t_{ACC} or t_{CE} . Fast page mode accesses are obtained by keeping the “read-page addresses” constant and changing the “intra-read page” addresses.

Writing Commands/Command Sequences

To write a command or command sequence (which includes programming data to the device and erasing sectors of memory), the system must drive WE# and CE# to V_{IL} , and OE# to V_{IH} .

The device features an **Unlock Bypass** mode to facilitate faster programming. Once the device enters the Unlock Bypass mode, only two write cycles are required to program a word, instead of four. [Word Program Command Sequence](#) contains details on programming data to the device using both standard and Unlock Bypass command sequences.

An erase operation can erase one sector, multiple sectors, or the entire device. [Table 6](#) and [Table 17](#) indicates the address space that each sector occupies.

See [DC Characteristics](#) for the active current specification for the write mode. [AC Characteristics](#) contains timing specification tables and timing diagrams for write operations.

Write Buffer

Write Buffer Programming allows the system write to a maximum of 16 words/32 bytes in one programming operation. This results in faster effective programming time than the standard programming algorithms. See [Write Buffer Programming](#) for more information.

Accelerated Program Operation

The device offers accelerated program operations through the ACC function. This is one of two functions provided by the WP#/ACC or ACC pin, depending on model number. This function is primarily intended to allow faster manufacturing throughput at the factory.

If the system asserts V_{HH} on this pin, the device automatically enters the aforementioned Unlock Bypass mode, temporarily unprotects any protected sector groups, and uses the higher voltage on the pin to reduce the time required for program operations. The system would use a two-cycle program command sequence as required by the Unlock Bypass mode. Removing V_{HH} from the WP#/ACC or ACC pin, depending on model number, returns the device to normal operation. *Note that the WP#/ACC or ACC pin must not be at V_{HH} for operations other than accelerated programming, or device damage may result. WP# has an internal pullup; when unconnected, WP# is at V_{IH} .*

Autoselect Functions

If the system writes the autoselect command sequence, the device enters the autoselect mode. The system can then read autoselect codes from the internal register (which is separate from the memory array) on DQ7–DQ0. Standard read cycle timings apply in this mode. See [Autoselect Mode](#) and [Autoselect Command Sequence](#) for more information.

Standby Mode

When the system is not reading or writing to the device, it can place the device in the standby mode. In this mode, current consumption is greatly reduced, and the outputs are placed in the high impedance state, independent of the OE# input.

The device enters the CMOS standby mode when the CE# and RESET# pins are both held at $V_{IO} \pm 0.3$ V. (Note that this is a more restricted voltage range than V_{IH} .) If CE# and RESET# are held at V_{IH} , but not within $V_{IO} \pm 0.3$ V, the device is in the standby mode, but the standby current is greater. The device requires standard access time (t_{CE}) for read access when the device is in either of these standby modes, before it is ready to read data.

If the device is deselected during erasure or programming, the device draws active current until the operation is completed.

See [DC Characteristics](#) for the standby current specification.

Automatic Sleep Mode

The automatic sleep mode minimizes Flash device energy consumption. The device automatically enables this mode when addresses remain stable for $t_{ACC} + 30$ ns. The automatic sleep mode is independent of the CE#, WE#, and OE# control signals. Standard address access timings provide new data when addresses are changed. While in sleep mode, output data is latched and always available to the system. See [DC Characteristics](#) for the automatic sleep mode current specification.

RESET#: Hardware Reset Pin

The RESET# pin provides a hardware method of resetting the device to reading array data. When the RESET# pin is driven low for at least a period of t_{RP} , the device immediately terminates any operation in progress, tristates all output pins, and ignores all read/write commands for the duration of the RESET# pulse. The device also resets the internal state machine to reading array data. The operation that was interrupted should be reinitiated once the device is ready to accept another command sequence, to ensure data integrity.

Current is reduced for the duration of the RESET# pulse. When RESET# is held at $V_{SS} \pm 0.3$ V, the device draws CMOS standby current (I_{CC5}). If RESET# is held at V_{IL} but not within $V_{SS} \pm 0.3$ V, the standby current is greater.

The RESET# pin may be tied to the system reset circuitry. A system reset would thus also reset the Flash memory, enabling the system to read the boot-up firmware from the Flash memory.

See [AC Characteristics](#) for RESET# parameters and to [Figure 15](#) for the timing diagram.

Output Disable Mode

When the OE# input is at V_{IH}, output from the device is disabled. The output pins are placed in the high impedance state.

Table 6. S29GL032M (Model R0) Sector Addresses

Sector	A21-A16	8-bit Address Range	Sector	A21-A16	8-bit Address Range	Sector	A21-A16	8-bit Address Range	Sector	A21-A16	8-bit Address Range
SA0	000000	000000-00FFFF	SA16	011000	100000-10FFFF	SA32	110000	200000-20FFFF	SA48	111000	300000-30FFFF
SA1	000001	010000-01FFFF	SA17	011001	110000-11FFFF	SA33	110001	210000-21FFFF	SA49	111001	310000-31FFFF
SA2	000010	020000-02FFFF	SA18	011010	120000-12FFFF	SA34	110010	220000-22FFFF	SA50	111010	320000-32FFFF
SA3	000011	030000-03FFFF	SA19	011011	130000-13FFFF	SA35	110011	230000-23FFFF	SA51	111011	330000-33FFFF
SA4	000100	040000-04FFFF	SA20	011100	140000-14FFFF	SA36	110100	240000-24FFFF	SA52	111100	340000-34FFFF
SA5	000101	050000-05FFFF	SA21	011101	150000-15FFFF	SA37	110101	250000-25FFFF	SA53	111101	350000-35FFFF
SA6	000110	060000-06FFFF	SA22	011110	160000-16FFFF	SA38	110110	260000-26FFFF	SA54	111110	360000-36FFFF
SA7	000111	070000-07FFFF	SA23	011011	170000-17FFFF	SA39	110111	270000-27FFFF	SA55	111011	370000-37FFFF
SA8	001000	080000-08FFFF	SA24	011100	180000-18FFFF	SA40	111000	280000-28FFFF	SA56	111100	380000-38FFFF
SA9	001001	090000-09FFFF	SA25	011101	190000-19FFFF	SA41	111001	290000-29FFFF	SA57	111101	390000-39FFFF
SA10	001010	0A0000-0AFFFF	SA26	011110	1A0000-1AFFFF	SA42	111010	2A0000-2AFFFF	SA58	111110	3A0000-3AFFFF
SA11	001011	0B0000-0BFFFF	SA27	011111	1B0000-1BFFFF	SA43	111011	2B0000-2BFFFF	SA59	111111	3B0000-3BFFFF
SA12	001100	0C0000-0CFFFF	SA28	011100	1C0000-1CFFFF	SA44	111100	2C0000-2CFFFF	SA60	111100	3C0000-3CFFFF
SA13	001101	0D0000-0DFFFF	SA29	011101	1D0000-1DFFFF	SA45	111101	2D0000-2DFFFF	SA61	111101	3D0000-3DFFFF
SA14	001110	0E0000-0EFFFF	SA30	011110	1E0000-1EFFFF	SA46	110111	2E0000-2EFFFF	SA62	111110	3E0000-3EFFFF
SA15	001111	0F0000-0FFFFF	SA31	011111	1F0000-1FFFFF	SA47	110111	2F0000-2FFFFF	SA63	111111	3F0000-3FFFFF

Table 7. S29GL032M (Models RI, R2) Sector Addresses

Sector	A20-A15	Sector Size (KB/Kwords)	8-bit Address Range	16-bit Address Range	Sector	A20-A15	Sector Size (KB/Kwords)	8-bit Address Range	16-bit Address Range
SA0	000000	64/32	000000-00FFFF	000000-007FFF	SA32	110000	64/32	200000-20FFFF	100000-107FFF
SA1	000001	64/32	010000-01FFFF	008000-00FFFF	SA33	110001	64/32	210000-21FFFF	108000-10FFFF
SA2	000010	64/32	020000-02FFFF	010000-017FFF	SA34	110010	64/32	220000-22FFFF	110000-117FFF
SA3	000011	64/32	030000-03FFFF	018000-01FFFF	SA35	110011	64/32	230000-23FFFF	118000-11FFFF
SA4	000100	64/32	040000-04FFFF	020000-027FFF	SA36	110100	64/32	240000-24FFFF	120000-127FFF
SA5	000101	64/32	050000-05FFFF	028000-02FFFF	SA37	110101	64/32	250000-25FFFF	128000-12FFFF
SA6	000110	64/32	060000-06FFFF	030000-037FFF	SA38	110110	64/32	260000-26FFFF	130000-137FFF
SA7	000111	64/32	070000-07FFFF	038000-037FFF	SA39	110111	64/32	270000-27FFFF	138000-137FFF
SA8	001000	64/32	080000-08FFFF	040000-047FFF	SA40	111000	64/32	280000-28FFFF	140000-147FFF
SA9	001001	64/32	090000-09FFFF	048000-047FFF	SA41	111001	64/32	290000-29FFFF	148000-147FFF
SA10	001010	64/32	0A0000-0AFFFF	050000-057FFF	SA42	111010	64/32	2A0000-2AFFFF	150000-157FFF
SA11	001011	64/32	0B0000-0BFFFF	058000-057FFF	SA43	111011	64/32	2B0000-2BFFFF	158000-157FFF
SA12	001100	64/32	0C0000-0CFFFF	060000-067FFF	SA44	111100	64/32	2C0000-2CFFFF	160000-167FFF
SA13	001101	64/32	0D0000-0DFFFF	068000-067FFF	SA45	111101	64/32	2D0000-2DFFFF	168000-167FFF
SA14	001110	64/32	0E0000-0EFFFF	070000-077FFF	SA46	110111	64/32	2E0000-2EFFFF	170000-177FFF
SA15	001111	64/32	0F0000-0FFFFF	078000-077FFF	SA47	110111	64/32	2F0000-2FFFFF	178000-177FFF
SA16	010000	64/32	100000-10FFFF	080000-087FFF	SA48	111000	64/32	300000-30FFFF	180000-187FFF
SA17	010001	64/32	110000-11FFFF	088000-087FFF	SA49	111001	64/32	310000-31FFFF	188000-187FFF
SA18	010010	64/32	120000-12FFFF	090000-097FFF	SA50	111010	64/32	320000-32FFFF	190000-197FFF
SA19	010011	64/32	130000-13FFFF	098000-097FFF	SA51	111011	64/32	330000-33FFFF	198000-197FFF
SA20	010100	64/32	140000-14FFFF	0A0000-0A7FFF	SA52	111100	64/32	340000-34FFFF	1A0000-1A7FFF
SA21	010101	64/32	150000-15FFFF	0A8000-0A7FFF	SA53	111101	64/32	350000-35FFFF	1A8000-1A7FFF
SA22	010110	64/32	160000-16FFFF	0B0000-0B7FFF	SA54	111110	64/32	360000-36FFFF	1B0000-1B7FFF
SA23	010111	64/32	170000-17FFFF	0B8000-0B7FFF	SA55	111011	64/32	370000-37FFFF	1B8000-1B7FFF
SA24	011000	64/32	180000-18FFFF	0C0000-0C7FFF	SA56	111001	64/32	380000-38FFFF	1C0000-1C7FFF
SA25	011001	64/32	190000-19FFFF	0C8000-0C7FFF	SA57	111010	64/32	390000-39FFFF	1C8000-1C7FFF
SA26	011010	64/32	1A0000-1AFFFF	0D0000-0D7FFF	SA58	111100	64/32	3A0000-3AFFFF	1D0000-1D7FFF
SA27	011011	64/32	1B0000-1BFFFF	0D8000-0D7FFF	SA59	111101	64/32	3B0000-3BFFFF	1D8000-1D7FFF
SA28	011100	64/32	1C0000-1CFFFF	0E0000-0E7FFF	SA60	111110	64/32	3C0000-3CFFFF	1E0000-1E7FFF
SA29	011101	64/32	1D0000-1DFFFF	0E8000-0E7FFF	SA61	111101	64/32	3D0000-3DFFFF	1E8000-1E7FFF
SA30	011110	64/32	1E0000-1EFFFF	0F0000-0F7FFF	SA62	111110	64/32	3E0000-3EFFFF	1F0000-1F7FFF
SA31	011111	64/32	1F0000-1FFFFF	0F8000-0F7FFF	SA63	111111	64/32	3F0000-3FFFFF	1F8000-1F7FFF

Table 8. S29GL032M (Models R3, R5) Top Boot Sector Addresses

Sector	A20–A12	Sector Size (KB/Kwords)	8-bit Address Range	16-bit Address Range	Sector	A20–A12	Sector Size (KB/Kwords)	8-bit Address Range	16-bit Address Range
SA0	000000xxx	64/32	000000h–00FFFFh	00000h–07FFFh	SA36	100100xxx	64/32	240000h–24FFFFh	120000h–127FFFh
SA1	000001xxx	64/32	010000h–01FFFFh	08000h–0FFFFh	SA37	100101xxx	64/32	250000h–25FFFFh	128000h–12FFFFh
SA2	000010xxx	64/32	020000h–02FFFFh	10000h–17FFFh	SA38	100110xxx	64/32	260000h–26FFFFh	130000h–137FFFh
SA3	000011xxx	64/32	030000h–03FFFFh	18000h–1FFFFh	SA39	100111xxx	64/32	270000h–27FFFFh	138000h–13FFFFh
SA4	000100xxx	64/32	040000h–04FFFFh	20000h–27FFFh	SA40	101000xxx	64/32	280000h–28FFFFh	140000h–147FFFh
SA5	000101xxx	64/32	050000h–05FFFFh	28000h–2FFFFh	SA41	101001xxx	64/32	290000h–29FFFFh	148000h–14FFFFh
SA6	000110xxx	64/32	060000h–06FFFFh	30000h–37FFFh	SA42	101010xxx	64/32	2A0000h–2AFFFFh	150000h–157FFFh
SA7	000111xxx	64/32	070000h–07FFFFh	38000h–3FFFFh	SA43	101011xxx	64/32	2B0000h–2BFFFFh	158000h–15FFFFh
SA8	001000xxx	64/32	080000h–08FFFFh	40000h–47FFFh	SA44	101100xxx	64/32	2C0000h–2CFFFFh	160000h–167FFFh
SA9	001001xxx	64/32	090000h–09FFFFh	48000h–4FFFFh	SA45	101101xxx	64/32	2D0000h–2DFFFFh	168000h–16FFFFh
SA10	001010xxx	64/32	0A0000h–0AFFFFh	50000h–57FFFh	SA46	101110xxx	64/32	2E0000h–2EFFFFh	170000h–177FFFh
SA11	001011xxx	64/32	0B0000h–0BFFFFh	58000h–5FFFFh	SA47	101111xxx	64/32	2F0000h–2FFFFh	178000h–17FFFFh
SA12	001100xxx	64/32	0C0000h–0CFFFFh	60000h–67FFFh	SA48	110000xxx	64/32	300000h–30FFFFh	180000h–187FFFh
SA13	001101xxx	64/32	0D0000h–0DFFFFh	68000h–6FFFFh	SA49	110001xxx	64/32	310000h–31FFFFh	188000h–18FFFFh
SA14	001110xxx	64/32	0E0000h–0EFFFFh	70000h–77FFFh	SA50	110010xxx	64/32	320000h–32FFFFh	190000h–197FFFh
SA15	001111xxx	64/32	0F0000h–0FFFFh	78000h–7FFFFh	SA51	110011xxx	64/32	330000h–33FFFFh	198000h–19FFFFh
SA16	010000xxx	64/32	100000h–00FFFFh	80000h–87FFFh	SA52	100100xxx	64/32	340000h–34FFFFh	1A0000h–1A7FFFh
SA17	010001xxx	64/32	110000h–11FFFFh	88000h–8FFFFh	SA53	110101xxx	64/32	350000h–35FFFFh	1A8000h–1AFFFFh
SA18	010010xxx	64/32	120000h–12FFFFh	90000h–97FFFh	SA54	110110xxx	64/32	360000h–36FFFFh	1B0000h–1B7FFFh
SA19	010011xxx	64/32	130000h–13FFFFh	98000h–9FFFFh	SA55	110111xxx	64/32	370000h–37FFFFh	1B8000h–1BFFFFh
SA20	010100xxx	64/32	140000h–14FFFFh	A0000h–A7FFFh	SA56	111000xxx	64/32	380000h–38FFFFh	1C0000h–1C7FFFh
SA21	010101xxx	64/32	150000h–15FFFFh	A8000h–AFFFFh	SA57	111001xxx	64/32	390000h–39FFFFh	1C8000h–1CFFFFh
SA22	010110xxx	64/32	160000h–16FFFFh	B0000h–B7FFFh	SA58	111010xxx	64/32	3A0000h–3AFFFFh	1D0000h–1D7FFFh
SA23	010111xxx	64/32	170000h–17FFFFh	B8000h–BFFFFh	SA59	111011xxx	64/32	3B0000h–3BFFFFh	1D8000h–1DFFFFh
SA24	011000xxx	64/32	180000h–18FFFFh	C0000h–C7FFFh	SA60	111100xxx	64/32	3C0000h–3CFFFFh	1E0000h–1E7FFFh
SA25	011001xxx	64/32	190000h–19FFFFh	C8000h–CFFFFh	SA61	111101xxx	64/32	3D0000h–3DFFFFh	1E8000h–1EFFFFh
SA26	011010xxx	64/32	1A0000h–1AFFFFh	D0000h–D7FFFh	SA62	111110xxx	64/32	3E0000h–3EFFFFh	1F0000h–1F7FFFh
SA27	011011xxx	64/32	1B0000h–1BFFFFh	D8000h–DFFFFh	SA63	111111000	8/4	3F0000h–3F1FFFh	1F8000h–1F8FFFh
SA28	011000xxx	64/32	1C0000h–1CFFFFh	E0000h–E7FFFh	SA64	111111001	8/4	3F2000h–3F3FFFh	1F9000h–1F9FFFh
SA29	011101xxx	64/32	1D0000h–1DFFFFh	E8000h–EFFFFh	SA65	111111010	8/4	3F4000h–3F5FFFh	1FA000h–1FAFFFh
SA30	011110xxx	64/32	1E0000h–1EFFFFh	F0000h–F7FFFh	SA66	111111011	8/4	3F6000h–3F7FFFh	1FB000h–1FBFFFh
SA31	011111xxx	64/32	1F0000h–1FFFFh	F8000h–FFFFh	SA67	111111100	8/4	3F8000h–3F9FFFh	1FC000h–1FCFFFh
SA32	100000xxx	64/32	200000h–20FFFFh	F9000h–107FFFh	SA68	111111101	8/4	3FA000h–3FBFFFh	1FD000h–1FDFFFh
SA33	100001xxx	64/32	210000h–21FFFFh	108000h–10FFFFh	SA69	111111110	8/4	3FC000h–3FDFFFh	1FE000h–1FEFFFh
SA34	100010xxx	64/32	220000h–22FFFFh	110000h–117FFFh	SA70	111111111	8/4	3FE000h–3FFFFh	1FF000h–1FFFFh
SA35	101011xxx	64/32	230000h–23FFFFh	118000h–11FFFFh					

Table 9. S29GL032M (Models R4, R6) Bottom Boot Sector Addresses (Sheet 1 of 2)

Sector	A20–A12	Sector Size (KB/Kwords)	8-bit Address Range	16-bit Address Range	Sector	A20–A12	Sector Size (KB/Kwords)	8-bit Address Range	16-bit Address Range
SA0	000000000	8/4	000000h–001FFFh	00000h–00FFFh	SA19	001100xxx	64/32	0C0000h–0CFFFFh	60000h–67FFFh
SA1	000000001	8/4	002000h–003FFFh	01000h–01FFFh	SA20	001101xxx	64/32	0D0000h–0DFFFFh	68000h–6FFFFh
SA2	000000010	8/4	004000h–005FFFh	02000h–02FFFh	SA21	001101xxx	64/32	0E0000h–0EFFFFh	70000h–77FFFh
SA3	000000011	8/4	006000h–007FFFh	03000h–03FFFh	SA22	001111xxx	64/32	0F0000h–0FFFFh	78000h–7FFFFh
SA4	000000100	8/4	008000h–009FFFh	04000h–04FFFh	SA23	010000xxx	64/32	100000h–00FFFFh	80000h–87FFFh
SA5	000000101	8/4	00A000h–00BFFFh	05000h–05FFFh	SA24	010001xxx	64/32	110000h–11FFFFh	88000h–8FFFFh
SA6	000000110	8/4	00C000h–00DFFFh	06000h–06FFFh	SA25	010010xxx	64/32	120000h–12FFFFh	90000h–97FFFh
SA7	000000111	8/4	00E000h–00FFFFh	07000h–07FFFh	SA26	010011xxx	64/32	130000h–13FFFFh	98000h–9FFFFh
SA8	000001xxx	64/32	010000h–01FFFFh	08000h–0FFFFh	SA27	010100xxx	64/32	140000h–14FFFFh	A0000h–A7FFFh
SA9	000010xxx	64/32	020000h–02FFFFh	10000h–17FFFh	SA28	010101xxx	64/32	150000h–15FFFFh	A8000h–AFFFFh
SA10	000011xxx	64/32	030000h–03FFFFh	18000h–1FFFFh	SA29	010110xxx	64/32	160000h–16FFFFh	B0000h–B7FFFh
SA11	000100xxx	64/32	040000h–04FFFFh	20000h–27FFFh	SA30	010111xxx	64/32	170000h–17FFFFh	B8000h–BFFFFh
SA12	000101xxx	64/32	050000h–05FFFFh	28000h–2FFFFh	SA31	011000xxx	64/32	180000h–18FFFFh	C0000h–C7FFFh
SA13	000110xxx	64/32	060000h–06FFFFh	30000h–37FFFh	SA32	011001xxx	64/32	190000h–19FFFFh	C8000h–CFFFFh
SA14	000111xxx	64/32	070000h–07FFFFh	38000h–3FFFFh	SA33	011010xxx	64/32	1A0000h–1AFFFFh	D0000h–D7FFFh
SA15	001000xxx	64/32	080000h–08FFFFh	40000h–47FFFh	SA34	011011xxx	64/32	1B0000h–1BFFFFh	D8000h–DFFFFh
SA16	001001xxx	64/32	090000h–09FFFFh	48000h–4FFFFh	SA35	011000xxx	64/32	1C0000h–1CFFFFh	E0000h–E7FFFh
SA17	001010xxx	64/32	0A0000h–0AFFFFh	50000h–57FFFh	SA36	011101xxx	64/32	1D0000h–1DFFFFh	E8000h–EFFFFh
SA18	001011xxx	64/32	0B0000h–0BFFFFh	58000h–5FFFFh	SA37	011110xxx	64/32	1E0000h–1EFFFFh	F0000h–F7FFFh

Table 9. S29GL032M (Models R4, R6) Bottom Boot Sector Addresses (Sheet 2 of 2)

Sector	A20–A12	Sector Size (KB/Kwords)	8-bit Address Range	16-bit Address Range	Sector	A20–A12	Sector Size (KB/Kwords)	8-bit Address Range	16-bit Address Range
SA38	011111xxx	64/32	1F0000h–1FFFFFh	F8000h–FFFFFh	SA55	110000xxx	64/32	300000h–30FFFFh	180000h–187FFFh
SA39	100000xxx	64/32	200000h–20FFFFh	F9000h–107FFFh	SA56	110001xxx	64/32	310000h–31FFFFh	188000h–18FFFFh
SA40	100001xxx	64/32	210000h–21FFFFh	108000h–10FFFFh	SA57	110010xxx	64/32	320000h–32FFFFh	190000h–197FFFh
SA41	100010xxx	64/32	220000h–22FFFFh	110000h–117FFFh	SA58	110011xxx	64/32	330000h–33FFFFh	198000h–19FFFFh
SA42	101011xxx	64/32	230000h–23FFFFh	118000h–11FFFFh	SA59	100100xxx	64/32	340000h–34FFFFh	1A0000h–1A7FFFh
SA43	100100xxx	64/32	240000h–24FFFFh	120000h–127FFFh	SA60	110101xxx	64/32	350000h–35FFFFh	1A8000h–1AFFFFh
SA44	100101xxx	64/32	250000h–25FFFFh	128000h–12FFFFh	SA61	110110xxx	64/32	360000h–36FFFFh	1B0000h–1B7FFFh
SA45	100110xxx	64/32	260000h–26FFFFh	130000h–137FFFh	SA62	110111xxx	64/32	370000h–37FFFFh	1B8000h–1BFFFFh
SA46	100111xxx	64/32	270000h–27FFFFh	138000h–13FFFFh	SA63	111000xxx	64/32	380000h–38FFFFh	1C0000h–1C7FFFh
SA47	101000xxx	64/32	280000h–28FFFFh	140000h–147FFFh	SA64	111001xxx	64/32	390000h–39FFFFh	1C8000h–1CFFFFh
SA48	101001xxx	64/32	290000h–29FFFFh	148000h–14FFFFh	SA65	111010xxx	64/32	3A0000h–3AFFFFh	1D0000h–1D7FFFh
SA49	101010xxx	64/32	2A0000h–2AFFFFh	150000h–157FFFh	SA66	111011xxx	64/32	3B0000h–3BFFFFh	1D8000h–1DFFFFh
SA50	101011xxx	64/32	2B0000h–2BFFFFh	158000h–15FFFFh	SA67	111100xxx	64/32	3C0000h–3CFFFFh	1E0000h–1E7FFFh
SA51	101100xxx	64/32	2C0000h–2CFFFFh	160000h–167FFFh	SA68	111101xxx	64/32	3D0000h–3DFFFFh	1E8000h–1EFFFFh
SA52	101101xxx	64/32	2D0000h–2DFFFFh	168000h–16FFFFh	SA69	111110xxx	64/32	3E0000h–3EFFFFh	1F0000h–1F7FFFh
SA53	101110xxx	64/32	2E0000h–2EFFFFh	170000h–177FFFh	SA70	111111xxx	64/32	3F0000h–3FFFFFh	1F8000h–1FFFFFh
SA54	101111xxx	64/32	2F0000h–2FFFFFh	178000h–17FFFFh					

Table 10. S29GL064M (Model R0) Sector Addresses

Sector	A22–A16	8-bit Address Range	Sector	A22–A16	8-bit Address Range	Sector	A22–A16	8-bit Address Range	Sector	A22–A16	8-bit Address Range
SA0	0000000	000000–00FFFF	SA32	0100000	200000–20FFFF	SA64	1000000	400000–40FFFF	SA96	1100000	600000–60FFFF
SA1	0000001	010000–01FFFF	SA33	0100001	210000–21FFFF	SA65	1000001	410000–41FFFF	SA97	1100001	610000–61FFFF
SA2	0000010	020000–02FFFF	SA34	0100010	220000–22FFFF	SA66	1000010	420000–42FFFF	SA98	1100010	620000–62FFFF
SA3	0000011	030000–03FFFF	SA35	0100011	230000–23FFFF	SA67	1000011	430000–43FFFF	SA99	1100011	630000–63FFFF
SA4	0000100	040000–04FFFF	SA36	0100100	240000–24FFFF	SA68	1000100	440000–44FFFF	SA100	1100100	640000–64FFFF
SA5	0000101	050000–05FFFF	SA37	0100101	250000–25FFFF	SA69	1000101	450000–45FFFF	SA101	1100101	650000–65FFFF
SA6	0000110	060000–06FFFF	SA38	0100110	260000–26FFFF	SA70	1000110	460000–46FFFF	SA102	1100110	660000–66FFFF
SA7	0000111	070000–07FFFF	SA39	0100111	270000–27FFFF	SA71	1000111	470000–47FFFF	SA103	1100111	670000–67FFFF
SA8	0001000	080000–08FFFF	SA40	0101000	280000–28FFFF	SA72	1001000	480000–48FFFF	SA104	1101000	680000–68FFFF
SA9	0001001	090000–09FFFF	SA41	0101001	290000–29FFFF	SA73	1001001	490000–49FFFF	SA105	1101001	690000–69FFFF
SA10	0001010	0A0000–0AFFFF	SA42	0101010	2A0000–2AFFFF	SA74	1001010	4A0000–4AFFFF	SA106	1101010	6A0000–6AFFFF
SA11	0001011	0B0000–0BFFFF	SA43	0101011	2B0000–2BFFFF	SA75	1001011	4B0000–4BFFFF	SA107	1101011	6B0000–6BFFFF
SA12	0001100	0C0000–0CFFFF	SA44	0101100	2C0000–2CFFFF	SA76	1001100	4C0000–4CFFFF	SA108	1101100	6C0000–6CFFFF
SA13	0001101	0D0000–0DFFFF	SA45	0101101	2D0000–2DFFFF	SA77	1001101	4D0000–4DFFFF	SA109	1101101	6D0000–6DFFFF
SA14	0001110	0E0000–0EFFFF	SA46	0101110	2E0000–2EFFFF	SA78	1001110	4E0000–4EFFFF	SA110	1101110	6E0000–6EFFFF
SA15	0001111	0F0000–0FFFFF	SA47	0101111	2F0000–2FFFFF	SA79	1001111	4F0000–4FFFFF	SA111	1101111	6F0000–6FFFFF
SA16	0010000	100000–10FFFF	SA48	0110000	300000–30FFFF	SA80	1010000	500000–50FFFF	SA112	1110000	700000–70FFFF
SA17	0010001	110000–11FFFF	SA49	0110001	310000–31FFFF	SA81	1010001	510000–51FFFF	SA113	1110001	710000–71FFFF
SA18	0010010	120000–12FFFF	SA50	0110010	320000–32FFFF	SA82	1010010	520000–52FFFF	SA114	1110010	720000–72FFFF
SA19	0010011	130000–13FFFF	SA51	0110011	330000–33FFFF	SA83	1010011	530000–53FFFF	SA115	1110011	730000–73FFFF
SA20	0010100	140000–14FFFF	SA52	0110100	340000–34FFFF	SA84	1010100	540000–54FFFF	SA116	1110100	740000–74FFFF
SA21	0010101	150000–15FFFF	SA53	0110101	350000–35FFFF	SA85	1010101	550000–55FFFF	SA117	1110101	750000–75FFFF
SA22	0010110	160000–16FFFF	SA54	0110110	360000–36FFFF	SA86	1010110	560000–56FFFF	SA118	1110110	760000–76FFFF
SA23	0010111	170000–17FFFF	SA55	0110111	370000–37FFFF	SA87	1010111	570000–57FFFF	SA119	1110111	770000–77FFFF
SA24	0011000	180000–18FFFF	SA56	0111000	380000–38FFFF	SA88	1011000	580000–58FFFF	SA120	1111000	780000–78FFFF
SA25	0011001	190000–19FFFF	SA57	0111001	390000–39FFFF	SA89	1011001	590000–59FFFF	SA121	1111001	790000–79FFFF
SA26	0011010	1A0000–1AFFFF	SA58	0111010	3A0000–3AFFFF	SA90	1011010	5A0000–5AFFFF	SA122	1111010	7A0000–7AFFFF
SA27	0011011	1B0000–1BFFFF	SA59	0111011	3B0000–3BFFFF	SA91	1011011	5B0000–5BFFFF	SA123	1111011	7B0000–7BFFFF
SA28	0011100	1C0000–1CFFFF	SA60	0111100	3C0000–3CFFFF	SA92	1011100	5C0000–5CFFFF	SA124	1111100	7C0000–7CFFFF
SA29	0011101	1D0000–1DFFFF	SA61	0111101	3D0000–3DFFFF	SA93	1011101	5D0000–5DFFFF	SA125	1111101	7D0000–7DFFFF
SA30	0011110	1E0000–1EFFFF	SA62	0111110	3E0000–3EFFFF	SA94	1011110	5E0000–5EFFFF	SA126	1111110	7E0000–7EFFFF
SA31	0011111	1F0000–1FFFFF	SA63	0111111	3F0000–3FFFFF	SA95	1011111	5F0000–5FFFFF	SA127	1111111	7F0000–7FFFFF

Table II. S29GL064M (Models RI, R2, R8, R9) Sector Addresses

Sector	A21-A15	Sector Size (KB/Kwords)	8-bit Address Range	16-bit Address Range	Sector	A21-A15	Sector Size (KB/Kwords)	8-bit Address Range	16-bit Address Range
SA0	000000	64/32	000000-00FFFF	000000-007FFF	SA64	100000	64/32	400000-40FFFF	200000-207FFF
SA1	000001	64/32	010000-01FFFF	008000-00FFFF	SA65	100001	64/32	410000-41FFFF	208000-20FFFF
SA2	000010	64/32	020000-02FFFF	010000-017FFF	SA66	100010	64/32	420000-42FFFF	210000-217FFF
SA3	000011	64/32	030000-03FFFF	018000-01FFFF	SA67	100011	64/32	430000-43FFFF	218000-21FFFF
SA4	000100	64/32	040000-04FFFF	020000-027FFF	SA68	100100	64/32	440000-44FFFF	220000-227FFF
SA5	000101	64/32	050000-05FFFF	028000-02FFFF	SA69	100101	64/32	450000-45FFFF	228000-22FFFF
SA6	000110	64/32	060000-06FFFF	030000-037FFF	SA70	100110	64/32	460000-46FFFF	230000-237FFF
SA7	000111	64/32	070000-07FFFF	038000-03FFFF	SA71	100111	64/32	470000-47FFFF	238000-23FFFF
SA8	000100	64/32	080000-08FFFF	040000-047FFF	SA72	100100	64/32	480000-48FFFF	240000-247FFF
SA9	000101	64/32	090000-09FFFF	048000-04FFFF	SA73	100101	64/32	490000-49FFFF	248000-24FFFF
SA10	000110	64/32	0A0000-0AFFFF	050000-057FFF	SA74	100110	64/32	4A0000-4AFFFF	250000-257FFF
SA11	000111	64/32	0B0000-0BFFFF	058000-05FFFF	SA75	100111	64/32	4B0000-4BFFFF	258000-25FFFF
SA12	000100	64/32	0C0000-0CFFFF	060000-067FFF	SA76	100100	64/32	4C0000-4CFFFF	260000-267FFF
SA13	000101	64/32	0D0000-0DFFFF	068000-06FFFF	SA77	100101	64/32	4D0000-4DFFFF	268000-26FFFF
SA14	000110	64/32	0E0000-0EFFFF	070000-077FFF	SA78	100110	64/32	4E0000-4EFFFF	270000-277FFF
SA15	000111	64/32	0F0000-0FFFFF	078000-077FFF	SA79	100111	64/32	4F0000-4FFFFF	278000-277FFF
SA16	001000	64/32	100000-10FFFF	080000-087FFF	SA80	101000	64/32	500000-50FFFF	280000-287FFF
SA17	001001	64/32	110000-11FFFF	088000-08FFFF	SA81	101001	64/32	510000-51FFFF	288000-28FFFF
SA18	001010	64/32	120000-12FFFF	090000-097FFF	SA82	101010	64/32	520000-52FFFF	290000-297FFF
SA19	001011	64/32	130000-13FFFF	098000-09FFFF	SA83	101011	64/32	530000-53FFFF	298000-29FFFF
SA20	001100	64/32	140000-14FFFF	0A0000-0A7FFF	SA84	101100	64/32	540000-54FFFF	2A0000-2A7FFF
SA21	001101	64/32	150000-15FFFF	0A8000-0AFFFF	SA85	101101	64/32	550000-55FFFF	2A8000-2AFFFF
SA22	001110	64/32	160000-16FFFF	0B0000-0B7FFF	SA86	101110	64/32	560000-56FFFF	2B0000-2B7FFF
SA23	001111	64/32	170000-17FFFF	0B8000-0BFFFF	SA87	101111	64/32	570000-57FFFF	2B8000-2BFFFF
SA24	001100	64/32	180000-18FFFF	0C0000-0C7FFF	SA88	101100	64/32	580000-58FFFF	2C0000-2C7FFF
SA25	001101	64/32	190000-19FFFF	0C8000-0CFFFF	SA89	101101	64/32	590000-59FFFF	2C8000-2CFFFF
SA26	001110	64/32	1A0000-1AFFFF	0D0000-0D7FFF	SA90	101110	64/32	5A0000-5AFFFF	2D0000-2D7FFF
SA27	001111	64/32	1B0000-1BFFFF	0D8000-0DFFFF	SA91	101111	64/32	5B0000-5BFFFF	2D8000-2DFFFF
SA28	001100	64/32	1C0000-1CFFFF	0E0000-0E7FFF	SA92	101100	64/32	5C0000-5CFFFF	2E0000-2E7FFF
SA29	001101	64/32	1D0000-1DFFFF	0E8000-0EFFFF	SA93	101101	64/32	5D0000-5DFFFF	2E8000-2EFFFF
SA30	001110	64/32	1E0000-1EFFFF	0F0000-0F7FFF	SA94	101110	64/32	5E0000-5EFFFF	2F0000-2F7FFF
SA31	001111	64/32	1F0000-1FFFFF	0F8000-0FFFFF	SA95	101111	64/32	5F0000-5FFFFF	2F8000-2FFFFF
SA32	010000	64/32	200000-20FFFF	100000-107FFF	SA96	110000	64/32	600000-60FFFF	300000-307FFF
SA33	010001	64/32	210000-21FFFF	108000-10FFFF	SA97	110001	64/32	610000-61FFFF	308000-30FFFF
SA34	010010	64/32	220000-22FFFF	110000-117FFF	SA98	110010	64/32	620000-62FFFF	310000-317FFF
SA35	010011	64/32	230000-23FFFF	118000-11FFFF	SA99	110011	64/32	630000-63FFFF	318000-31FFFF
SA36	010100	64/32	240000-24FFFF	120000-127FFF	SA100	110100	64/32	640000-64FFFF	320000-327FFF
SA37	010101	64/32	250000-25FFFF	128000-12FFFF	SA101	110101	64/32	650000-65FFFF	328000-32FFFF
SA38	010110	64/32	260000-26FFFF	130000-137FFF	SA102	110110	64/32	660000-66FFFF	330000-337FFF
SA39	010111	64/32	270000-27FFFF	138000-13FFFF	SA103	110111	64/32	670000-67FFFF	338000-33FFFF
SA40	011000	64/32	280000-28FFFF	140000-147FFF	SA104	111000	64/32	680000-68FFFF	340000-347FFF
SA41	011001	64/32	290000-29FFFF	148000-14FFFF	SA105	111001	64/32	690000-69FFFF	348000-34FFFF
SA42	011010	64/32	2A0000-2AFFFF	150000-157FFF	SA106	111010	64/32	6A0000-6AFFFF	350000-357FFF
SA43	011011	64/32	2B0000-2BFFFF	158000-15FFFF	SA107	111011	64/32	6B0000-6BFFFF	358000-35FFFF
SA44	011100	64/32	2C0000-2CFFFF	160000-167FFF	SA108	111100	64/32	6C0000-6CFFFF	360000-367FFF
SA45	011101	64/32	2D0000-2DFFFF	168000-16FFFF	SA109	111101	64/32	6D0000-6DFFFF	368000-36FFFF
SA46	011110	64/32	2E0000-2EFFFF	170000-177FFF	SA110	111110	64/32	6E0000-6EFFFF	370000-377FFF
SA47	011111	64/32	2F0000-2FFFFF	178000-17FFFF	SA111	111111	64/32	6F0000-6FFFFF	378000-37FFFF
SA48	011000	64/32	300000-30FFFF	180000-187FFF	SA112	111000	64/32	700000-70FFFF	380000-387FFF
SA49	011001	64/32	310000-31FFFF	188000-18FFFF	SA113	111001	64/32	710000-71FFFF	388000-38FFFF
SA50	011010	64/32	320000-32FFFF	190000-197FFF	SA114	111010	64/32	720000-72FFFF	390000-397FFF
SA51	011011	64/32	330000-33FFFF	198000-19FFFF	SA115	111011	64/32	730000-73FFFF	398000-39FFFF
SA52	011100	64/32	340000-34FFFF	1A0000-1A7FFF	SA116	111100	64/32	740000-74FFFF	3A0000-3A7FFF
SA53	011101	64/32	350000-35FFFF	1A8000-1AFFFF	SA117	111101	64/32	750000-75FFFF	3A8000-3AFFFF
SA54	011110	64/32	360000-36FFFF	1B0000-1B7FFF	SA118	111110	64/32	760000-76FFFF	3B0000-3B7FFF
SA55	011111	64/32	370000-37FFFF	1B8000-1BFFFF	SA119	111111	64/32	770000-77FFFF	3B8000-3BFFFF
SA56	011000	64/32	380000-38FFFF	1C0000-1C7FFF	SA120	111000	64/32	780000-78FFFF	3C0000-3C7FFF
SA57	011001	64/32	390000-39FFFF	1C8000-1CFFFF	SA121	111001	64/32	790000-79FFFF	3C8000-3CFFFF
SA58	011010	64/32	3A0000-3AFFFF	1D0000-1D7FFF	SA122	111010	64/32	7A0000-7AFFFF	3D0000-3D7FFF
SA59	011011	64/32	3B0000-3BFFFF	1D8000-1DFFFF	SA123	111011	64/32	7B0000-7BFFFF	3D8000-3DFFFF
SA60	011100	64/32	3C0000-3CFFFF	1E0000-1E7FFF	SA124	111100	64/32	7C0000-7CFFFF	3E0000-3E7FFF
SA61	011101	64/32	3D0000-3DFFFF	1E8000-1EFFFF	SA125	111101	64/32	7D0000-7DFFFF	3E8000-3EFFFF
SA62	011110	64/32	3E0000-3EFFFF	1F0000-1F7FFF	SA126	111110	64/32	7E0000-7EFFFF	3F0000-3F7FFF
SA63	011111	64/32	3F0000-3FFFFF	1F8000-1FFFFF	SA127	111111	64/32	7F0000-7FFFFF	3F8000-3FFFFF

Table I2. S29GL064M (Model R3) Top Boot Sector Addresses

Sector	A21-A12	Sector Size (KB/ Kwords)	8-bit Address Range	16-bit Address Range	Sector	A21-A12	Sector Size (KB/ Kwords)	8-bit Address Range	16-bit Address Range
SA0	0000000xxx	64/32	000000h-00FFFFh	00000h-07FFFh	SA68	1000100xxx	64/32	440000h-44FFFFh	220000h-227FFFh
SA1	0000001xxx	64/32	010000h-01FFFFh	08000h-0FFFFh	SA69	1000101xxx	64/32	450000h-45FFFFh	228000h-22FFFFh
SA2	0000010xxx	64/32	020000h-02FFFFh	10000h-17FFFh	SA70	1000110xxx	64/32	460000h-46FFFFh	230000h-237FFFh
SA3	0000011xxx	64/32	030000h-03FFFFh	18000h-1FFFFh	SA71	1000111xxx	64/32	470000h-47FFFFh	238000h-23FFFFh
SA4	0000100xxx	64/32	040000h-04FFFFh	20000h-27FFFh	SA72	1001000xxx	64/32	480000h-48FFFFh	240000h-247FFFh
SA5	0000101xxx	64/32	050000h-05FFFFh	28000h-2FFFFh	SA73	1001001xxx	64/32	490000h-49FFFFh	248000h-24FFFFh
SA6	0000110xxx	64/32	060000h-06FFFFh	30000h-37FFFh	SA74	1001010xxx	64/32	4A0000h-4AFFFFh	250000h-257FFFh
SA7	0000111xxx	64/32	070000h-07FFFFh	38000h-3FFFFh	SA75	1001011xxx	64/32	4B0000h-4BFFFFh	258000h-25FFFFh
SA8	0001000xxx	64/32	080000h-08FFFFh	40000h-47FFFh	SA76	1001100xxx	64/32	4C0000h-4CFFFFh	260000h-267FFFh
SA9	0001001xxx	64/32	090000h-09FFFFh	48000h-4FFFFh	SA77	1001101xxx	64/32	4D0000h-4DFFFFh	268000h-26FFFFh
SA10	0001010xxx	64/32	0A0000h-0AFFFFh	50000h-57FFFh	SA78	1001110xxx	64/32	4E0000h-4EFFFFh	270000h-277FFFh
SA11	0001011xxx	64/32	0B0000h-0BFFFFh	58000h-5FFFFh	SA79	1001111xxx	64/32	4F0000h-4FFFFh	278000h-27FFFFh
SA12	0001100xxx	64/32	0C0000h-0CFFFFh	60000h-67FFFh	SA80	1010000xxx	64/32	500000h-50FFFFh	280000h-28FFFFh
SA13	0001101xxx	64/32	0D0000h-0DFFFFh	68000h-6FFFFh	SA81	1010001xxx	64/32	510000h-51FFFFh	288000h-28FFFFh
SA14	0001110xxx	64/32	0E0000h-0EFFFFh	70000h-77FFFh	SA82	1010010xxx	64/32	520000h-52FFFFh	290000h-297FFFh
SA15	0001111xxx	64/32	0F0000h-0FFFFh	78000h-7FFFFh	SA83	1010011xxx	64/32	530000h-53FFFFh	298000h-29FFFFh
SA16	0010000xxx	64/32	100000h-00FFFFh	80000h-87FFFh	SA84	1010100xxx	64/32	540000h-54FFFFh	2A0000h-2A7FFFh
SA17	0010001xxx	64/32	110000h-11FFFFh	88000h-8FFFFh	SA85	1010101xxx	64/32	550000h-55FFFFh	2A8000h-2AFFFFh
SA18	0010010xxx	64/32	120000h-12FFFFh	90000h-97FFFh	SA86	1010110xxx	64/32	560000h-56FFFFh	2B0000h-2B7FFFh
SA19	0010011xxx	64/32	130000h-13FFFFh	98000h-9FFFFh	SA87	1010111xxx	64/32	570000h-57FFFFh	2B8000h-2BFFFFh
SA20	0010100xxx	64/32	140000h-14FFFFh	A0000h-A7FFFh	SA88	1011000xxx	64/32	580000h-58FFFFh	2C0000h-2C7FFFh
SA21	0010101xxx	64/32	150000h-15FFFFh	A8000h-AFFFFh	SA89	1011001xxx	64/32	590000h-59FFFFh	2C8000h-2CFFFFh
SA22	0010110xxx	64/32	160000h-16FFFFh	B0000h-B7FFFh	SA90	1011010xxx	64/32	5A0000h-5AFFFFh	2D0000h-2D7FFFh
SA23	0010111xxx	64/32	170000h-17FFFFh	B8000h-BFFFFh	SA91	1011011xxx	64/32	5B0000h-5BFFFFh	2D8000h-2DFFFFh
SA24	0011000xxx	64/32	180000h-18FFFFh	C0000h-C7FFFh	SA92	1011100xxx	64/32	5C0000h-5CFFFFh	2E0000h-2E7FFFh
SA25	0011001xxx	64/32	190000h-19FFFFh	C8000h-CFFFFh	SA93	1011101xxx	64/32	5D0000h-5DFFFFh	2E8000h-2EFFFFh
SA26	0011010xxx	64/32	1A0000h-1AFFFFh	D0000h-D7FFFh	SA94	1011110xxx	64/32	5E0000h-5EFFFFh	2F0000h-2F7FFFh
SA27	0011011xxx	64/32	1B0000h-1BFFFFh	D8000h-DFFFFh	SA95	1011111xxx	64/32	5F0000h-5FFFFh	2F8000h-2FFFFh
SA28	0011000xxx	64/32	1C0000h-1CFFFFh	E0000h-E7FFFh	SA96	1100000xxx	64/32	600000h-60FFFFh	300000h-307FFFh
SA29	0011101xxx	64/32	1D0000h-1DFFFFh	E8000h-EFFFFh	SA97	1100001xxx	64/32	610000h-61FFFFh	308000h-30FFFFh
SA30	0011110xxx	64/32	1E0000h-1EFFFFh	F0000h-F7FFFh	SA98	1100010xxx	64/32	620000h-62FFFFh	310000h-317FFFh
SA31	0011111xxx	64/32	1F0000h-1FFFFh	F8000h-FFFFh	SA99	1100011xxx	64/32	630000h-63FFFFh	318000h-31FFFFh
SA32	0100000xxx	64/32	200000h-20FFFFh	F9000h-107FFFh	SA100	1100100xxx	64/32	640000h-64FFFFh	320000h-327FFFh
SA33	0100001xxx	64/32	210000h-21FFFFh	108000h-10FFFFh	SA101	1100101xxx	64/32	650000h-65FFFFh	328000h-32FFFFh
SA34	0100010xxx	64/32	220000h-22FFFFh	110000h-117FFFh	SA102	1100110xxx	64/32	660000h-66FFFFh	330000h-337FFFh
SA35	0101011xxx	64/32	230000h-23FFFFh	118000h-11FFFFh	SA103	1100111xxx	64/32	670000h-67FFFFh	338000h-33FFFFh
SA36	0100100xxx	64/32	240000h-24FFFFh	120000h-127FFFh	SA104	1101000xxx	64/32	680000h-68FFFFh	340000h-347FFFh
SA37	0100101xxx	64/32	250000h-25FFFFh	128000h-12FFFFh	SA105	1101001xxx	64/32	690000h-69FFFFh	348000h-347FFFh
SA38	0100110xxx	64/32	260000h-26FFFFh	130000h-137FFFh	SA106	1101010xxx	64/32	6A0000h-6AFFFFh	350000h-357FFFh
SA39	0100111xxx	64/32	270000h-27FFFFh	138000h-13FFFFh	SA107	1101011xxx	64/32	6B0000h-6BFFFFh	358000h-35FFFFh
SA40	0101000xxx	64/32	280000h-28FFFFh	140000h-147FFFh	SA108	1101100xxx	64/32	6C0000h-6CFFFFh	360000h-367FFFh
SA41	0101001xxx	64/32	290000h-29FFFFh	148000h-14FFFFh	SA109	1101101xxx	64/32	6D0000h-6DFFFFh	368000h-36FFFFh
SA42	0101010xxx	64/32	2A0000h-2AFFFFh	150000h-157FFFh	SA110	1101110xxx	64/32	6E0000h-6EFFFFh	370000h-377FFFh
SA43	0101011xxx	64/32	2B0000h-2BFFFFh	158000h-15FFFFh	SA111	1101111xxx	64/32	6F0000h-6FFFFFh	378000h-377FFFh
SA44	0101100xxx	64/32	2C0000h-2CFFFFh	160000h-167FFFh	SA112	1110000xxx	64/32	700000h-70FFFFh	380000h-387FFFh
SA45	0101101xxx	64/32	2D0000h-2DFFFFh	168000h-16FFFFh	SA113	1110001xxx	64/32	710000h-71FFFFh	388000h-38FFFFh
SA46	0101110xxx	64/32	2E0000h-2EFFFFh	170000h-177FFFh	SA114	1110010xxx	64/32	720000h-72FFFFh	390000h-397FFFh
SA47	0101111xxx	64/32	2F0000h-2FFFFh	178000h-177FFFh	SA115	1110011xxx	64/32	730000h-73FFFFh	398000h-39FFFFh
SA48	0110000xxx	64/32	300000h-30FFFFh	180000h-187FFFh	SA116	1110100xxx	64/32	740000h-74FFFFh	3A0000h-3A7FFFh
SA49	0110001xxx	64/32	310000h-31FFFFh	188000h-18FFFFh	SA117	1110101xxx	64/32	750000h-75FFFFh	3A8000h-3AFFFFh
SA50	0110010xxx	64/32	320000h-32FFFFh	190000h-197FFFh	SA118	1110110xxx	64/32	760000h-76FFFFh	3B0000h-3B7FFFh
SA51	0110011xxx	64/32	330000h-33FFFFh	198000h-19FFFFh	SA119	1110111xxx	64/32	770000h-77FFFFh	3B8000h-3BFFFFh
SA52	0100100xxx	64/32	340000h-34FFFFh	1A0000h-1A7FFFh	SA120	1111000xxx	64/32	780000h-78FFFFh	3C0000h-3C7FFFh
SA53	0110101xxx	64/32	350000h-35FFFFh	1A8000h-1AFFFFh	SA121	1111001xxx	64/32	790000h-79FFFFh	3C8000h-3CFFFFh
SA54	0110110xxx	64/32	360000h-36FFFFh	1B0000h-1B7FFFh	SA122	1111010xxx	64/32	7A0000h-7AFFFFh	3D0000h-3D7FFFh
SA55	0110111xxx	64/32	370000h-37FFFFh	1B8000h-1BFFFFh	SA123	1111011xxx	64/32	7B0000h-7BFFFFh	3D8000h-3DFFFFh
SA56	0111000xxx	64/32	380000h-38FFFFh	1C0000h-1C7FFFh	SA124	1111100xxx	64/32	7C0000h-7CFFFFh	3E0000h-3E7FFFh
SA57	0111001xxx	64/32	390000h-39FFFFh	1C8000h-1CFFFFh	SA125	1111101xxx	64/32	7D0000h-7DFFFFh	3E8000h-3EFFFFh
SA58	0111010xxx	64/32	3A0000h-3AFFFFh	1D0000h-1D7FFFh	SA126	1111110xxx	64/32	7E0000h-7EFFFFh	3F0000h-3F7FFFh
SA59	0111011xxx	64/32	3B0000h-3BFFFFh	1D8000h-1DFFFFh	SA127	1111111000	8/4	7F0000h-7F1FFFh	3F8000h-3F8FFFh
SA60	0111100xxx	64/32	3C0000h-3CFFFFh	1E0000h-1E7FFFh	SA128	1111111001	8/4	7F2000h-7F3FFFh	3F9000h-3F9FFFh
SA61	0111101xxx	64/32	3D0000h-3DFFFFh	1E8000h-1EFFFFh	SA129	1111111010	8/4	7F4000h-7F5FFFh	3FA000h-3FAFFFh
SA62	0111110xxx	64/32	3E0000h-3EFFFFh	1F0000h-1F7FFFh	SA130	1111111011	8/4	7F6000h-7F7FFFh	3FB000h-3FBFFFh
SA63	0111111xxx	64/32	3F0000h-3FFFFh	1F8000h-1FFFFh	SA131	1111111100	8/4	7F8000h-7F9FFFh	3FC000h-3FCFFFh
SA64	1000000xxx	64/32	400000h-40FFFFh	200000h-207FFFh	SA132	1111111101	8/4	7FA000h-7FBFFFh	3FD000h-3FDFFFh
SA65	1000001xxx	64/32	410000h-41FFFFh	208000h-20FFFFh	SA133	1111111110	8/4	7FC000h-7FDFFFh	3FE000h-3FEFFFh
SA66	1000010xxx	64/32	420000h-42FFFFh	210000h-217FFFh	SA134	1111111111	8/4	7FE000h-7FFFFh	3FF000h-3FFFFh
SA67	1000011xxx	64/32	430000h-43FFFFh	218000h-21FFFFh					

Table I3. S29GL064M (Model R4) Bottom Boot Sector Addresses

Sector	A21-A12	Sector Size (KB/ Kwords)	8-bit Address Range	16-bit Address Range	Sector	A21-A12	Sector Size (KB/ Kwords)	8-bit Address Range	16-bit Address Range
SA0	000000000	8/4	000000h-001FFFh	00000h-00FFFh	SA68	0111101xxx	64/32	3D0000h-3DFFFFh	1E8000h-1EFFFFh
SA1	000000001	8/4	002000h-003FFFh	01000h-01FFFh	SA69	0111110xxx	64/32	3E0000h-3EFFFFh	1F0000h-1F7FFFh
SA2	000000010	8/4	004000h-005FFFh	02000h-02FFFh	SA70	0111111xxx	64/32	3F0000h-3FFFFFh	1F8000h-1FFFFFh
SA3	000000011	8/4	006000h-007FFFh	03000h-03FFFh	SA71	1000000xxx	64/32	400000h-40FFFFh	200000h-207FFFh
SA4	000000100	8/4	008000h-009FFFh	04000h-04FFFh	SA72	1000001xxx	64/32	410000h-41FFFFh	208000h-20FFFFh
SA5	000000101	8/4	00A000h-00BFFFh	05000h-05FFFh	SA73	1000010xxx	64/32	420000h-42FFFFh	210000h-217FFFh
SA6	000000110	8/4	00C000h-00DFFFh	06000h-06FFFh	SA74	1000011xxx	64/32	430000h-43FFFFh	218000h-21FFFFh
SA7	000000111	8/4	00E000h-00FFFFFFh	07000h-07FFFh	SA75	1000100xxx	64/32	440000h-44FFFFh	220000h-227FFFh
SA8	0000001xxx	64/32	010000h-01FFFh	08000h-08FFFh	SA76	1000101xxx	64/32	450000h-45FFFFh	228000h-22FFFFh
SA9	0000010xxx	64/32	020000h-02FFFh	10000h-17FFFh	SA77	1000110xxx	64/32	460000h-46FFFFh	230000h-237FFFh
SA10	0000011xxx	64/32	030000h-03FFFh	18000h-1FFFFh	SA78	1000111xxx	64/32	470000h-47FFFFh	238000h-23FFFFh
SA11	0000100xxx	64/32	040000h-04FFFh	20000h-27FFFh	SA79	1001000xxx	64/32	480000h-48FFFFh	240000h-247FFFh
SA12	0000101xxx	64/32	050000h-05FFFh	28000h-2FFFFh	SA80	1001001xxx	64/32	490000h-49FFFFh	248000h-24FFFFh
SA13	0000110xxx	64/32	060000h-06FFFh	30000h-37FFFh	SA81	1001010xxx	64/32	4A0000h-4AFFFFh	250000h-257FFFh
SA14	0000111xxx	64/32	070000h-07FFFh	38000h-3FFFFh	SA82	1001011xxx	64/32	4B0000h-4BFFFFh	258000h-25FFFFh
SA15	0001000xxx	64/32	080000h-08FFFh	40000h-47FFFh	SA83	1001100xxx	64/32	4C0000h-4CFFFFh	260000h-267FFFh
SA16	0001001xxx	64/32	090000h-09FFFh	48000h-4FFFFh	SA84	1001101xxx	64/32	4D0000h-4DFFFFh	268000h-26FFFFh
SA17	0001010xxx	64/32	0A0000h-0AFFFh	50000h-57FFFh	SA85	1001110xxx	64/32	4E0000h-4EFFFFh	270000h-277FFFh
SA18	0001011xxx	64/32	0B0000h-0BFFFh	58000h-5FFFFh	SA86	1001111xxx	64/32	4F0000h-4FFFFFh	278000h-27FFFFh
SA19	0001100xxx	64/32	0C0000h-0CFFFh	60000h-67FFFh	SA87	1010000xxx	64/32	500000h-50FFFFh	280000h-28FFFFh
SA20	0001101xxx	64/32	0D0000h-0DFFFh	68000h-6FFFFh	SA88	1010001xxx	64/32	510000h-51FFFFh	288000h-28FFFFh
SA21	0001110xxx	64/32	0E0000h-0EFFFh	70000h-77FFFh	SA89	1010010xxx	64/32	520000h-52FFFFh	290000h-297FFFh
SA22	0001111xxx	64/32	0F0000h-0FFFFFh	78000h-7FFFFh	SA90	1010011xxx	64/32	530000h-53FFFFh	298000h-29FFFFh
SA23	0010000xxx	64/32	100000h-00FFFh	80000h-87FFFh	SA91	1010100xxx	64/32	540000h-54FFFFh	2A0000h-2A7FFFh
SA24	0010001xxx	64/32	110000h-11FFFh	88000h-8FFFFh	SA92	1010101xxx	64/32	550000h-55FFFFh	2A8000h-2AFFFFh
SA25	0010010xxx	64/32	120000h-12FFFh	90000h-97FFFh	SA93	1010110xxx	64/32	560000h-56FFFFh	2B0000h-2B7FFFh
SA26	0010011xxx	64/32	130000h-13FFFh	98000h-9FFFFh	SA94	1010111xxx	64/32	570000h-57FFFFh	2B8000h-2BFFFFh
SA27	0010100xxx	64/32	140000h-14FFFh	A0000h-A7FFFh	SA95	1011000xxx	64/32	580000h-58FFFFh	2C0000h-2C7FFFh
SA28	0010101xxx	64/32	150000h-15FFFh	A8000h-AFFFFh	SA96	1011001xxx	64/32	590000h-59FFFFh	2C8000h-2CFFFFh
SA29	0010110xxx	64/32	160000h-16FFFh	B0000h-B7FFFh	SA97	1011010xxx	64/32	5A0000h-5AFFFFh	2D0000h-2D7FFFh
SA30	0010111xxx	64/32	170000h-17FFFh	B8000h-BFFFFh	SA98	1011011xxx	64/32	5B0000h-5BFFFFh	2D8000h-2DFFFFh
SA31	0011000xxx	64/32	180000h-18FFFh	C0000h-C7FFFh	SA99	1011100xxx	64/32	5C0000h-5CFFFFh	2E0000h-2E7FFFh
SA32	0011001xxx	64/32	190000h-19FFFh	C8000h-CFFFFh	SA100	1011101xxx	64/32	5D0000h-5DFFFFh	2E8000h-2EFFFFh
SA33	0011010xxx	64/32	1A0000h-1AFFFh	D0000h-D7FFFh	SA101	1011110xxx	64/32	5E0000h-5EFFFFh	2F0000h-2FFFFFh
SA34	0011011xxx	64/32	1B0000h-1BFFFh	D8000h-DFFFFh	SA102	1011111xxx	64/32	5F0000h-5FFFFFh	2F8000h-2FFFFFh
SA35	0011000xxx	64/32	1C0000h-1CFFFh	E0000h-E7FFFh	SA103	1100000xxx	64/32	600000h-60FFFFh	300000h-307FFFh
SA36	0011101xxx	64/32	1D0000h-1DFFFh	E8000h-EFFFFh	SA104	1100001xxx	64/32	610000h-61FFFFh	308000h-30FFFFh
SA37	0011110xxx	64/32	1E0000h-1EFFFh	F0000h-F7FFFh	SA105	1100010xxx	64/32	620000h-62FFFFh	310000h-317FFFh
SA38	0011111xxx	64/32	1F0000h-1FFFFh	F8000h-FFFFFh	SA106	1100011xxx	64/32	630000h-63FFFFh	318000h-31FFFFh
SA39	0100000xxx	64/32	200000h-20FFFh	F9000h-107FFFh	SA107	1100100xxx	64/32	640000h-64FFFFh	320000h-327FFFh
SA40	0100001xxx	64/32	210000h-21FFFh	108000h-10FFFFh	SA108	1100101xxx	64/32	650000h-65FFFFh	328000h-32FFFFh
SA41	0100010xxx	64/32	220000h-22FFFh	110000h-117FFFh	SA109	1100110xxx	64/32	660000h-66FFFFh	330000h-337FFFh
SA42	0101011xxx	64/32	230000h-23FFFh	118000h-11FFFFh	SA110	1100111xxx	64/32	670000h-67FFFFh	338000h-33FFFFh
SA43	0100100xxx	64/32	240000h-24FFFh	120000h-127FFFh	SA111	1101000xxx	64/32	680000h-68FFFFh	340000h-347FFFh
SA44	0100101xxx	64/32	250000h-25FFFh	128000h-12FFFFh	SA112	1101001xxx	64/32	690000h-69FFFFh	348000h-34FFFFh
SA45	0100110xxx	64/32	260000h-26FFFh	130000h-137FFFh	SA113	1101010xxx	64/32	6A0000h-6AFFFFh	350000h-357FFFh
SA46	0100111xxx	64/32	270000h-27FFFh	138000h-13FFFFh	SA114	1101011xxx	64/32	6B0000h-6BFFFFh	358000h-35FFFFh
SA47	0101000xxx	64/32	280000h-28FFFh	140000h-147FFFh	SA115	1101100xxx	64/32	6C0000h-6CFFFFh	360000h-367FFFh
SA48	0101001xxx	64/32	290000h-29FFFh	148000h-14FFFFh	SA116	1101101xxx	64/32	6D0000h-6DFFFFh	368000h-36FFFFh
SA49	0101010xxx	64/32	2A0000h-2AFFFh	150000h-157FFFh	SA117	1101110xxx	64/32	6E0000h-6EFFFFh	370000h-377FFFh
SA50	0101011xxx	64/32	2B0000h-2BFFFh	158000h-15FFFFh	SA118	1101111xxx	64/32	6F0000h-6FFFFFh	378000h-37FFFFh
SA51	0101100xxx	64/32	2C0000h-2CFFFh	160000h-167FFFh	SA119	1110000xxx	64/32	700000h-70FFFFh	380000h-387FFFh
SA52	0101101xxx	64/32	2D0000h-2DFFFh	168000h-16FFFFh	SA120	1110001xxx	64/32	710000h-71FFFFh	388000h-38FFFFh
SA53	0101110xxx	64/32	2E0000h-2EFFFh	170000h-177FFFh	SA121	1110010xxx	64/32	720000h-72FFFFh	390000h-397FFFh
SA54	0101111xxx	64/32	2F0000h-2FFFFFh	178000h-17FFFFh	SA122	1110011xxx	64/32	730000h-73FFFFh	398000h-39FFFFh
SA55	0110000xxx	64/32	300000h-30FFFh	180000h-187FFFh	SA123	1110100xxx	64/32	740000h-74FFFFh	3A0000h-3A7FFFh
SA56	0110001xxx	64/32	310000h-31FFFh	188000h-18FFFFh	SA124	1110101xxx	64/32	750000h-75FFFFh	3A8000h-3AFFFFh
SA57	0110010xxx	64/32	320000h-32FFFh	190000h-197FFFh	SA125	1110110xxx	64/32	760000h-76FFFFh	3B0000h-3B7FFFh
SA58	0110011xxx	64/32	330000h-33FFFh	198000h-19FFFFh	SA126	1110111xxx	64/32	770000h-77FFFFh	3B8000h-3BFFFFh
SA59	0100100xxx	64/32	340000h-34FFFh	1A0000h-1A7FFFh	SA127	1111000xxx	64/32	780000h-78FFFFh	3C0000h-3C7FFFh
SA60	0100101xxx	64/32	350000h-35FFFh	1A8000h-1AFFFFh	SA128	1111001xxx	64/32	790000h-79FFFFh	3C8000h-3CFFFFh
SA61	0110110xxx	64/32	360000h-36FFFh	1B0000h-1B7FFFh	SA129	1111010xxx	64/32	7A0000h-7AFFFFh	3D0000h-3D7FFFh
SA62	0110111xxx	64/32	370000h-37FFFh	1B8000h-1BFFFFh	SA130	1111011xxx	64/32	7B0000h-7BFFFFh	3D8000h-3DFFFFh
SA63	0111000xxx	64/32	380000h-38FFFh	1C0000h-1C7FFFh	SA131	1111100xxx	64/32	7C0000h-7CFFFFh	3E0000h-3E7FFFh
SA64	0111001xxx	64/32	390000h-39FFFh	1C8000h-1CFFFFh	SA132	1111101xxx	64/32	7D0000h-7DFFFFh	3E8000h-3EFFFFh
SA65	0111010xxx	64/32	3A0000h-3AFFFh	1D0000h-1D7FFFh	SA133	1111110xxx	64/32	7E0000h-7EFFFFh	3F0000h-3F7FFFh
SA66	0111011xxx	64/32	3B0000h-3BFFFh	1D8000h-1DFFFFh	SA134	1111111000	64/32	7F0000h-7FFFFFh	3F8000h-3FFFFFh
SA67	0111100xxx	64/32	3C0000h-3CFFFh	1E0000h-1E7FFFh					

Table 14. S29GL064M (Model R5) Sector Addresses

Sector	A21-A15	16-bit Address Range	Sector	A21-A15	16-bit Address Range	Sector	A21-A15	16-bit Address Range
SA0	0 0 0 0 0 0 0	000000-007FFF	SA43	0 1 1 0 1 0 1 1	158000-15FFFF	SA86	1 1 0 1 0 1 1 0	2B0000-2B7FFF
SA1	0 0 0 0 0 0 1	008000-00FFFF	SA44	0 1 1 0 1 1 0 0	160000-167FFF	SA87	1 1 0 1 0 1 1 1	2B8000-2BFFFF
SA2	0 0 0 0 0 1 0	010000-017FFF	SA45	0 1 1 0 1 1 0 1	168000-16FFFF	SA88	1 1 0 1 1 0 0 0	2C0000-2C7FFF
SA3	0 0 0 0 0 1 1	018000-01FFFF	SA46	0 1 1 0 1 1 1 0	170000-177FFF	SA89	1 1 0 1 1 0 0 1	2C8000-2CFFFF
SA4	0 0 0 0 1 0 0	020000-027FFF	SA47	0 1 1 0 1 1 1 1	178000-17FFFF	SA90	1 1 0 1 1 0 1 0	2D0000-2D7FFF
SA5	0 0 0 0 1 0 1	028000-02FFFF	SA48	0 1 1 1 0 0 0 0	180000-187FFF	SA91	1 1 0 1 1 0 1 1	2D8000-2DFFFF
SA6	0 0 0 0 1 1 0	030000-037FFF	SA49	0 1 1 1 0 0 0 1	188000-18FFFF	SA92	1 1 0 1 1 1 0 0	2E0000-2E7FFF
SA7	0 0 0 0 1 1 1	038000-03FFFF	SA50	0 1 1 1 0 0 1 0	190000-197FFF	SA93	1 1 0 1 1 1 0 1	2E8000-2EFFFF
SA8	0 0 0 1 0 0 0	040000-047FFF	SA51	0 1 1 1 0 0 1 1	198000-19FFFF	SA94	1 1 0 1 1 1 1 0	2F0000-2F7FFF
SA9	0 0 0 1 0 0 1	048000-04FFFF	SA52	0 1 1 1 0 1 0 0	1A0000-1A7FFF	SA95	1 1 0 1 1 1 1 1	2F8000-2FFFFF
SA10	0 0 0 1 0 1 0	050000-057FFF	SA53	0 1 1 1 0 1 0 1	1A8000-1AFFFF	SA96	1 1 1 0 0 0 0 0	300000-307FFF
SA11	0 0 0 1 0 1 1	058000-05FFFF	SA54	0 1 1 1 0 1 1 0	1B0000-1B7FFF	SA97	1 1 1 0 0 0 0 1	308000-30FFFF
SA12	0 0 0 1 1 0 0	060000-067FFF	SA55	0 1 1 1 0 1 1 1	1B8000-1BFFFF	SA98	1 1 1 0 0 0 1 0	310000-317FFF
SA13	0 0 0 1 1 0 1	068000-06FFFF	SA56	0 1 1 1 1 0 0 0	1C0000-1C7FFF	SA99	1 1 1 0 0 0 1 1	318000-31FFFF
SA14	0 0 0 1 1 1 0	070000-077FFF	SA57	0 1 1 1 1 0 0 1	1C8000-1CFFFF	SA100	1 1 1 0 0 1 0 0	320000-327FFF
SA15	0 0 0 1 1 1 1	078000-07FFFF	SA58	0 1 1 1 1 0 1 0	1D0000-1D7FFF	SA101	1 1 1 0 0 1 0 1	328000-32FFFF
SA16	0 0 1 0 0 0 0	080000-087FFF	SA59	0 1 1 1 1 0 1 1	1D8000-1DFFFF	SA102	1 1 1 0 0 1 1 0	330000-337FFF
SA17	0 0 1 0 0 0 1	088000-08FFFF	SA60	0 1 1 1 1 1 0 0	1E0000-1E7FFF	SA103	1 1 1 0 0 1 1 1	338000-33FFFF
SA18	0 0 1 0 0 1 0	090000-097FFF	SA61	0 1 1 1 1 1 0 1	1E8000-1EFFFF	SA104	1 1 1 0 1 0 0 0	340000-347FFF
SA19	0 0 1 0 0 1 1	098000-09FFFF	SA62	0 1 1 1 1 1 1 0	1F0000-1F7FFF	SA105	1 1 1 0 1 0 0 1	348000-34FFFF
SA20	0 0 1 0 1 0 0	0A0000-0A7FFF	SA63	0 1 1 1 1 1 1 1	1F8000-1FFFFF	SA106	1 1 1 0 1 0 1 0	350000-357FFF
SA21	0 0 1 0 1 0 1	0A8000-0AFFFF	SA64	1 0 0 0 0 0 0 0	200000-207FFF	SA107	1 1 1 0 1 0 1 1	358000-35FFFF
SA22	0 0 1 0 1 1 0	0B0000-0B7FFF	SA65	1 0 0 0 0 0 0 1	208000-20FFFF	SA108	1 1 1 0 1 1 0 0	360000-367FFF
SA23	0 0 1 0 1 1 1	0B8000-0BFFFF	SA66	1 0 0 0 0 0 1 0	210000-217FFF	SA109	1 1 1 0 1 1 0 1	368000-36FFFF
SA24	0 0 1 1 0 0 0	0C0000-0C7FFF	SA67	1 0 0 0 0 1 1 1	218000-21FFFF	SA110	1 1 1 0 1 1 1 0	370000-377FFF
SA25	0 0 1 1 0 0 1	0C8000-0CFFFF	SA68	1 0 0 0 1 0 0 0	220000-227FFF	SA111	1 1 1 0 1 1 1 1	378000-37FFFF
SA26	0 0 1 1 0 1 0	0D0000-0D7FFF	SA69	1 0 0 0 1 0 0 1	228000-22FFFF	SA112	1 1 1 1 0 0 0 0	380000-387FFF
SA27	0 0 1 1 0 1 1	0D8000-0DFFFF	SA70	1 0 0 0 1 1 0 0	230000-237FFF	SA113	1 1 1 1 0 0 0 1	388000-38FFFF
SA28	0 0 1 1 1 0 0	0E0000-0E7FFF	SA71	1 0 0 0 1 1 1 1	238000-23FFFF	SA114	1 1 1 1 0 0 1 0	390000-397FFF
SA29	0 0 1 1 1 0 1	0E8000-0EFFFF	SA72	1 0 0 1 0 0 0 0	240000-247FFF	SA115	1 1 1 1 0 0 1 1	398000-39FFFF
SA30	0 0 1 1 1 1 0	0F0000-0F7FFF	SA73	1 0 0 1 0 0 0 1	248000-24FFFF	SA116	1 1 1 1 0 1 0 0	3A0000-3A7FFF
SA31	0 0 1 1 1 1 1	0F8000-0FFFFF	SA74	1 0 0 1 0 0 1 0	250000-257FFF	SA117	1 1 1 1 0 1 0 1	3A8000-3AFFFF
SA32	0 1 0 0 0 0 0	100000-107FFF	SA75	1 0 0 1 0 0 1 1	258000-25FFFF	SA118	1 1 1 1 0 1 1 0	3B0000-3B7FFF
SA33	0 1 0 0 0 0 1	108000-10FFFF	SA76	1 0 0 1 1 0 0 0	260000-267FFF	SA119	1 1 1 1 0 1 1 1	3B8000-3BFFFF
SA34	0 1 0 0 0 1 0	110000-117FFF	SA77	1 0 0 1 1 0 0 1	268000-26FFFF	SA120	1 1 1 1 1 0 0 0	3C0000-3C7FFF
SA35	0 1 0 0 0 1 1	118000-11FFFF	SA78	1 0 0 1 1 1 0 0	270000-277FFF	SA121	1 1 1 1 1 0 0 1	3C8000-3CFFFF
SA36	0 1 0 0 1 0 0	120000-127FFF	SA79	1 0 0 1 1 1 1 1	278000-27FFFF	SA122	1 1 1 1 1 0 1 0	3D0000-3D7FFF
SA37	0 1 0 0 1 0 1	128000-12FFFF	SA80	1 0 1 1 0 0 0 0	280000-287FFF	SA123	1 1 1 1 1 0 1 1	3D8000-3DFFFF
SA38	0 1 0 0 1 1 0	130000-137FFF	SA81	1 0 1 1 0 0 0 1	288000-28FFFF	SA124	1 1 1 1 1 1 0 0	3E0000-3E7FFF
SA39	0 1 0 0 1 1 1	138000-13FFFF	SA82	1 0 1 1 0 0 1 0	290000-297FFF	SA125	1 1 1 1 1 1 0 1	3E8000-3EFFFF
SA40	0 1 0 1 0 0 0	140000-147FFF	SA83	1 0 1 1 0 0 1 1	298000-29FFFF	SA126	1 1 1 1 1 1 1 0	3F0000-3F7FFF
SA41	0 1 0 1 0 0 1	148000-14FFFF	SA84	1 0 1 1 0 1 0 0	2A0000-2A7FFF	SA127	1 1 1 1 1 1 1 1	3F8000-3FFFFF
SA42	0 1 0 1 0 1 0	150000-157FFF	SA85	1 0 1 1 0 1 0 1	2A8000-2AFFFF			

Table I5. S29GL064M (Model R6, R7) Sector Addresses

Sector	A21-A15	16-bit Address Range	Sector	A21-A15	16-bit Address Range	Sector	A21-A15	16-bit Address Range
SA0	00000000	000000-007FFF	SA43	01101011	158000-15FFFF	SA86	11010110	2B0000-2B7FFF
SA1	00000001	008000-00FFFF	SA44	01101100	160000-167FFF	SA87	11010111	2B8000-2BFFFF
SA2	00000010	010000-017FFF	SA45	01101101	168000-16FFFF	SA88	11011000	2C0000-2C7FFF
SA3	00000011	018000-01FFFF	SA46	01101110	170000-177FFF	SA89	11011001	2C8000-2CFFFF
SA4	00000100	020000-027FFF	SA47	01101111	178000-17FFFF	SA90	11011010	2D0000-2D7FFF
SA5	00000101	028000-02FFFF	SA48	01110000	180000-187FFF	SA91	11011011	2D8000-2DFFFF
SA6	00000110	030000-037FFF	SA49	01110001	188000-18FFFF	SA92	11011100	2E0000-2E7FFF
SA7	00000111	038000-03FFFF	SA50	01110010	190000-197FFF	SA93	11011101	2E8000-2EFFFF
SA8	00001000	040000-047FFF	SA51	01110011	198000-19FFFF	SA94	11011110	2F0000-2F7FFF
SA9	00001001	048000-04FFFF	SA52	01110010	1A0000-1A7FFF	SA95	11011111	2F8000-2FFFFF
SA10	00001010	050000-057FFF	SA53	01110101	1A8000-1AFFFF	SA96	11100000	300000-307FFF
SA11	00001011	058000-05FFFF	SA54	01110110	1B0000-1B7FFF	SA97	11100001	308000-30FFFF
SA12	00001100	060000-067FFF	SA55	01110111	1B8000-1BFFFF	SA98	11100010	310000-317FFF
SA13	00001101	068000-06FFFF	SA56	01111000	1C0000-1C7FFF	SA99	11100011	318000-31FFFF
SA14	00001110	070000-077FFF	SA57	01111001	1C8000-1CFFFF	SA100	11100100	320000-327FFF
SA15	00001111	078000-07FFFF	SA58	01111010	1D0000-1D7FFF	SA101	11100101	328000-32FFFF
SA16	00010000	080000-087FFF	SA59	01111011	1D8000-1DFFFF	SA102	11100110	330000-337FFF
SA17	00010001	088000-08FFFF	SA60	01111100	1E0000-1E7FFF	SA103	11100111	338000-33FFFF
SA18	00010010	090000-097FFF	SA61	01111101	1E8000-1EFFFF	SA104	11101000	340000-347FFF
SA19	00010011	098000-09FFFF	SA62	01111110	1F0000-1F7FFF	SA105	11101001	348000-34FFFF
SA20	00010100	0A0000-0A7FFF	SA63	01111111	1F8000-1FFFFF	SA106	11101010	350000-357FFF
SA21	00010101	0A8000-0AFFFF	SA64	10000000	200000-207FFF	SA107	11101011	358000-35FFFF
SA22	00010110	0B0000-0B7FFF	SA65	10000001	208000-20FFFF	SA108	11101100	360000-367FFF
SA23	00010111	0B8000-0BFFFF	SA66	10000010	210000-217FFF	SA109	11101101	368000-36FFFF
SA24	00011000	0C0000-0C7FFF	SA67	10000011	218000-21FFFF	SA110	11101110	370000-377FFF
SA25	00011001	0C8000-0CFFFF	SA68	10000100	220000-227FFF	SA111	11101111	378000-37FFFF
SA26	00011010	0D0000-0D7FFF	SA69	10000101	228000-22FFFF	SA112	11110000	380000-387FFF
SA27	00011011	0D8000-0DFFFF	SA70	10000110	230000-237FFF	SA113	11110001	388000-38FFFF
SA28	00011100	0E0000-0E7FFF	SA71	10000111	238000-23FFFF	SA114	11110010	390000-397FFF
SA29	00011101	0E8000-0EFFFF	SA72	10001000	240000-247FFF	SA115	11110011	398000-39FFFF
SA30	00011110	0F0000-0F7FFF	SA73	10001001	248000-24FFFF	SA116	11110100	3A0000-3A7FFF
SA31	00011111	0F8000-0FFFFF	SA74	10001010	250000-257FFF	SA117	11110101	3A8000-3AFFFF
SA32	01000000	100000-107FFF	SA75	10001011	258000-25FFFF	SA118	11110110	3B0000-3B7FFF
SA33	01000001	108000-10FFFF	SA76	10001100	260000-267FFF	SA119	11110111	3B8000-3BFFFF
SA34	01000010	110000-117FFF	SA77	10001101	268000-26FFFF	SA120	11111000	3C0000-3C7FFF
SA35	01000011	118000-11FFFF	SA78	10001110	270000-277FFF	SA121	11111001	3C8000-3CFFFF
SA36	01000100	120000-127FFF	SA79	10001111	278000-27FFFF	SA122	11111010	3D0000-3D7FFF
SA37	01000101	128000-12FFFF	SA80	10010000	280000-287FFF	SA123	11111011	3D8000-3DFFFF
SA38	01000110	130000-137FFF	SA81	10010001	288000-28FFFF	SA124	11111100	3E0000-3E7FFF
SA39	01000111	138000-13FFFF	SA82	10010010	290000-297FFF	SA125	11111101	3E8000-3EFFFF
SA40	01001000	140000-147FFF	SA83	10010011	298000-29FFFF	SA126	11111110	3F0000-3F7FFF
SA41	01001001	148000-14FFFF	SA84	10010100	2A0000-2A7FFF	SA127	11111111	3F8000-3FFFFF
SA42	01001010	150000-157FFF	SA85	10010101	2A8000-2AFFFF			

Table I6. S29GLI28M Sector Address Table (Sheet I of 2)

Sector	A22-A15	Sector Size (KB/Kwords)	8-bit Address Range	16-bit Address Range	Sector	A22-A15	Sector Size (KB/Kwords)	8-bit Address Range	16-bit Address Range
SA0	00000000	64/32	000000-00FFFF	000000-007FFF	SA68	010000100	64/32	440000-44FFFF	220000-227FFF
SA1	00000001	64/32	010000-01FFFF	008000-00FFFF	SA69	010000101	64/32	450000-45FFFF	228000-22FFFF
SA2	00000010	64/32	020000-02FFFF	010000-017FFF	SA70	010000110	64/32	460000-46FFFF	230000-237FFF
SA3	00000011	64/32	030000-03FFFF	018000-01FFFF	SA71	010000111	64/32	470000-47FFFF	238000-23FFFF
SA4	00000100	64/32	040000-04FFFF	020000-027FFF	SA72	010001000	64/32	480000-48FFFF	240000-247FFF
SA5	00000101	64/32	050000-05FFFF	028000-02FFFF	SA73	010001001	64/32	490000-49FFFF	248000-24FFFF
SA6	00000110	64/32	060000-06FFFF	030000-037FFF	SA74	010001010	64/32	4A0000-4AFFFF	250000-257FFF
SA7	00000111	64/32	070000-07FFFF	038000-03FFFF	SA75	010001011	64/32	4B0000-4BFFFF	258000-25FFFF
SA8	00001000	64/32	080000-08FFFF	040000-047FFF	SA76	010001100	64/32	4C0000-4CFFFF	260000-267FFF
SA9	00001001	64/32	090000-09FFFF	048000-04FFFF	SA77	010001101	64/32	4D0000-4DFFFF	268000-26FFFF
SA10	00001010	64/32	0A0000-0AFFFF	050000-057FFF	SA78	010001110	64/32	4E0000-4EFFFF	270000-277FFF
SA11	00001011	64/32	0B0000-0BFFFF	058000-05FFFF	SA79	010001111	64/32	4F0000-4FFFFF	278000-27FFFF
SA12	00001100	64/32	0C0000-0CFFFF	060000-067FFF	SA80	010100000	64/32	500000-50FFFF	280000-287FFF
SA13	00001101	64/32	0D0000-0DFFFF	068000-06FFFF	SA81	010100001	64/32	510000-51FFFF	288000-28FFFF
SA14	00001110	64/32	0E0000-0EFFFF	070000-077FFF	SA82	010100010	64/32	520000-52FFFF	290000-297FFF
SA15	00001111	64/32	0F0000-0FFFFF	078000-07FFFF	SA83	010100011	64/32	530000-53FFFF	298000-29FFFF
SA16	00010000	64/32	100000-10FFFF	080000-087FFF	SA84	010100100	64/32	540000-54FFFF	2A0000-2A7FFF
SA17	00010001	64/32	110000-11FFFF	088000-08FFFF	SA85	010100101	64/32	550000-55FFFF	2A8000-2AFFFF
SA18	00010010	64/32	120000-12FFFF	090000-097FFF	SA86	010100110	64/32	560000-56FFFF	2B0000-2B7FFF
SA19	00010011	64/32	130000-13FFFF	098000-09FFFF	SA87	010100111	64/32	570000-57FFFF	2B8000-2BFFFF
SA20	00010100	64/32	140000-14FFFF	0A0000-0A7FFF	SA88	010101000	64/32	580000-58FFFF	2C0000-2C7FFF
SA21	00010101	64/32	150000-15FFFF	0A8000-0AFFFF	SA89	010101001	64/32	590000-59FFFF	2C8000-2CFFFF
SA22	00010110	64/32	160000-16FFFF	0B0000-0B7FFF	SA90	010101010	64/32	5A0000-5AFFFF	2D0000-2D7FFF
SA23	00010111	64/32	170000-17FFFF	0B8000-0BFFFF	SA91	010101011	64/32	5B0000-5BFFFF	2D8000-2DFFFF
SA24	00011000	64/32	180000-18FFFF	0C0000-0C7FFF	SA92	010101100	64/32	5C0000-5CFFFF	2E0000-2E7FFF
SA25	00011001	64/32	190000-19FFFF	0C8000-0CFFFF	SA93	010101101	64/32	5D0000-5DFFFF	2E8000-2EFFFF
SA26	00011010	64/32	1A0000-1AFFFF	0D0000-0D7FFF	SA94	010101110	64/32	5E0000-5EFFFF	2F0000-2F7FFF
SA27	00011011	64/32	1B0000-1BFFFF	0D8000-0DFFFF	SA95	010101111	64/32	5F0000-5FFFFF	2F8000-2FFFFF
SA28	00011100	64/32	1C0000-1CFFFF	0E0000-0E7FFF	SA96	011000000	64/32	600000-60FFFF	300000-307FFF
SA29	00011101	64/32	1D0000-1DFFFF	0E8000-0EFFFF	SA97	011000001	64/32	610000-61FFFF	308000-30FFFF
SA30	00011110	64/32	1E0000-1EFFFF	0F0000-0F7FFF	SA98	011000010	64/32	620000-62FFFF	310000-317FFF
SA31	00011111	64/32	1F0000-1FFFFF	0F8000-0FFFFF	SA99	011000011	64/32	630000-63FFFF	318000-31FFFF
SA32	00100000	64/32	200000-20FFFF	100000-107FFF	SA100	011000100	64/32	640000-64FFFF	320000-327FFF
SA33	00100001	64/32	210000-21FFFF	108000-10FFFF	SA101	011000101	64/32	650000-65FFFF	328000-32FFFF
SA34	00100010	64/32	220000-22FFFF	110000-117FFF	SA102	011000110	64/32	660000-66FFFF	330000-337FFF
SA35	00100011	64/32	230000-23FFFF	118000-11FFFF	SA103	011000111	64/32	670000-67FFFF	338000-33FFFF
SA36	00100100	64/32	240000-24FFFF	120000-127FFF	SA104	011001000	64/32	680000-68FFFF	340000-347FFF
SA37	00100101	64/32	250000-25FFFF	128000-12FFFF	SA105	011001001	64/32	690000-69FFFF	348000-34FFFF
SA38	00100110	64/32	260000-26FFFF	130000-137FFF	SA106	011001010	64/32	6A0000-6AFFFF	350000-357FFF
SA39	00100111	64/32	270000-27FFFF	138000-13FFFF	SA107	011001011	64/32	6B0000-6BFFFF	358000-35FFFF
SA40	00101000	64/32	280000-28FFFF	140000-147FFF	SA108	011001100	64/32	6C0000-6CFFFF	360000-367FFF
SA41	00101001	64/32	290000-29FFFF	148000-14FFFF	SA109	011001101	64/32	6D0000-6DFFFF	368000-36FFFF
SA42	00101010	64/32	2A0000-2AFFFF	150000-157FFF	SA110	011001110	64/32	6E0000-6EFFFF	370000-377FFF
SA43	00101011	64/32	2B0000-2BFFFF	158000-15FFFF	SA111	011001111	64/32	6F0000-6FFFFF	378000-37FFFF
SA44	00101100	64/32	2C0000-2CFFFF	160000-167FFF	SA112	011010000	64/32	700000-70FFFF	380000-387FFF
SA45	00101101	64/32	2D0000-2DFFFF	168000-16FFFF	SA113	011010001	64/32	710000-71FFFF	388000-38FFFF
SA46	00101110	64/32	2E0000-2EFFFF	170000-177FFF	SA114	011010010	64/32	720000-72FFFF	390000-397FFF
SA47	00101111	64/32	2F0000-2FFFFF	178000-17FFFF	SA115	011010011	64/32	730000-73FFFF	398000-39FFFF
SA48	00110000	64/32	300000-30FFFF	180000-187FFF	SA116	011010100	64/32	740000-74FFFF	3A0000-3A7FFF
SA49	00110001	64/32	310000-31FFFF	188000-18FFFF	SA117	011010101	64/32	750000-75FFFF	3A8000-3AFFFF
SA50	00110010	64/32	320000-32FFFF	190000-197FFF	SA118	011010110	64/32	760000-76FFFF	3B0000-3B7FFF
SA51	00110011	64/32	330000-33FFFF	198000-19FFFF	SA119	011010111	64/32	770000-77FFFF	3B8000-3BFFFF
SA52	00110100	64/32	340000-34FFFF	1A0000-1A7FFF	SA120	011011000	64/32	780000-78FFFF	3C0000-3C7FFF
SA53	00110101	64/32	350000-35FFFF	1A8000-1AFFFF	SA121	011011001	64/32	790000-79FFFF	3C8000-3CFFFF
SA54	00110110	64/32	360000-36FFFF	1B0000-1B7FFF	SA122	011011010	64/32	7A0000-7AFFFF	3D0000-3D7FFF
SA55	00110111	64/32	370000-37FFFF	1B8000-1BFFFF	SA123	011011011	64/32	7B0000-7BFFFF	3D8000-3DFFFF
SA56	00111000	64/32	380000-38FFFF	1C0000-1C7FFF	SA124	011011100	64/32	7C0000-7CFFFF	3E0000-3E7FFF
SA57	00111001	64/32	390000-39FFFF	1C8000-1CFFFF	SA125	011011101	64/32	7D0000-7DFFFF	3E8000-3EFFFF
SA58	00111010	64/32	3A0000-3AFFFF	1D0000-1D7FFF	SA126	011011110	64/32	7E0000-7EFFFF	3F0000-3F7FFF
SA59	00111011	64/32	3B0000-3BFFFF	1D8000-1DFFFF	SA127	011011111	64/32	7F0000-7FFFFF	3F8000-3FFFFF
SA60	00111100	64/32	3C0000-3CFFFF	1E0000-1E7FFF	SA128	100000000	64/32	800000-80FFFF	400000-407FFF
SA61	00111101	64/32	3D0000-3DFFFF	1E8000-1EFFFF	SA129	100000001	64/32	810000-81FFFF	408000-40FFFF
SA62	00111110	64/32	3E0000-3EFFFF	1F0000-1F7FFF	SA130	100000010	64/32	820000-82FFFF	410000-417FFF
SA63	00111111	64/32	3F0000-3FFFFF	1F8000-1FFFFF	SA131	100000011	64/32	830000-83FFFF	418000-41FFFF
SA64	01000000	64/32	400000-40FFFF	200000-207FFF	SA132	100000100	64/32	840000-84FFFF	420000-427FFF
SA65	01000001	64/32	410000-41FFFF	208000-20FFFF	SA133	100000101	64/32	850000-85FFFF	428000-42FFFF
SA66	01000010	64/32	420000-42FFFF	210000-217FFF	SA134	100000110	64/32	860000-86FFFF	430000-437FFF
SA67	01000011	64/32	430000-43FFFF	218000-21FFFF	SA135	100000111	64/32	870000-87FFFF	438000-43FFFF

Table I6. S29GLI28M Sector Address Table (Sheet 2 of 2)

Sector	A22-A15	Sector Size (KB/Kwords)	8-bit Address Range	16-bit Address Range	Sector	A22-A15	Sector Size (KB/Kwords)	8-bit Address Range	16-bit Address Range
SA136	1 0 0 0 1 0 0 0	64/32	880000-88FFFF	440000-447FFF	SA196	1 1 0 0 0 1 0 0	64/32	C40000-C4FFFF	620000-627FFF
SA137	1 0 0 0 1 0 0 1	64/32	890000-89FFFF	448000-44FFFF	SA197	1 1 0 0 0 1 0 1	64/32	C50000-C5FFFF	628000-62FFFF
SA138	1 0 0 0 1 0 0 10	64/32	8A0000-8AFFFF	450000-457FFF	SA198	1 1 0 0 0 1 1 0	64/32	C60000-C6FFFF	630000-637FFF
SA139	1 0 0 0 1 0 0 11	64/32	8B0000-8BFFFF	458000-45FFFF	SA199	1 1 0 0 0 1 1 1	64/32	C70000-C7FFFF	638000-63FFFF
SA140	1 0 0 0 1 1 0 0	64/32	8C0000-8CFFFF	460000-467FFF	SA200	1 1 0 0 1 0 0 0	64/32	C80000-C8FFFF	640000-647FFF
SA141	1 0 0 0 1 1 0 1	64/32	8D0000-8DFFFF	468000-46FFFF	SA201	1 1 0 0 1 0 0 1	64/32	C90000-C9FFFF	648000-64FFFF
SA142	1 0 0 0 1 1 0 10	64/32	8E0000-8EFFFF	470000-477FFF	SA202	1 1 0 0 1 0 1 0	64/32	CA0000-CAFFFF	650000-657FFF
SA143	1 0 0 0 1 1 0 11	64/32	8F0000-8FFFFF	478000-47FFFF	SA203	1 1 0 0 1 0 1 1	64/32	CB0000-CBFFFF	658000-65FFFF
SA144	1 0 0 1 0 0 0 0	64/32	900000-90FFFF	480000-487FFF	SA204	1 1 0 0 1 1 0 0	64/32	CC0000-CCFFFF	660000-667FFF
SA145	1 0 0 1 0 0 0 1	64/32	910000-91FFFF	488000-48FFFF	SA205	1 1 0 0 1 1 0 1	64/32	CD0000-CDFFFF	668000-66FFFF
SA146	1 0 0 1 0 0 0 10	64/32	920000-92FFFF	490000-497FFF	SA206	1 1 0 0 1 1 1 0	64/32	CE0000-CEFFFF	670000-677FFF
SA147	1 0 0 1 0 0 0 11	64/32	930000-93FFFF	498000-49FFFF	SA207	1 1 0 0 1 1 1 1	64/32	CF0000-CFFFFF	678000-67FFFF
SA148	1 0 0 1 0 1 0 0	64/32	940000-94FFFF	4A0000-4A7FFF	SA208	1 1 0 1 0 0 0 0	64/32	D00000-D0FFFF	680000-687FFF
SA149	1 0 0 1 0 1 0 1	64/32	950000-95FFFF	4A8000-4AFFFF	SA209	1 1 0 1 0 0 0 1	64/32	D10000-D1FFFF	688000-68FFFF
SA150	1 0 0 1 0 1 0 10	64/32	960000-96FFFF	4B0000-4B7FFF	SA210	1 1 0 1 0 0 1 0	64/32	D20000-D2FFFF	690000-697FFF
SA151	1 0 0 1 0 1 0 11	64/32	970000-97FFFF	4B8000-4BFFFF	SA211	1 1 0 1 0 0 1 1	64/32	D30000-D3FFFF	698000-69FFFF
SA152	1 0 0 1 1 0 0 0	64/32	980000-98FFFF	4C0000-4C7FFF	SA212	1 1 0 1 0 1 0 0	64/32	D40000-D4FFFF	6A0000-6A7FFF
SA153	1 0 0 1 1 0 0 1	64/32	990000-99FFFF	4C8000-4CFFFF	SA213	1 1 0 1 0 1 0 1	64/32	D50000-D5FFFF	6A8000-6AFFFF
SA154	1 0 0 1 1 0 0 10	64/32	9A0000-9AFFFF	4D0000-4D7FFF	SA214	1 1 0 1 0 1 1 0	64/32	D60000-D6FFFF	6B0000-6B7FFF
SA155	1 0 0 1 1 0 0 11	64/32	9B0000-9BFFFF	4D8000-4DFFFF	SA215	1 1 0 1 0 1 1 1	64/32	D70000-D7FFFF	6B8000-6BFFFF
SA156	1 0 0 1 1 1 0 0	64/32	9C0000-9CFFFF	4E0000-4E7FFF	SA216	1 1 0 1 1 0 0 0	64/32	D80000-D8FFFF	6C0000-6C7FFF
SA157	1 0 0 1 1 1 0 1	64/32	9D0000-9DFFFF	4E8000-4EFFFF	SA217	1 1 0 1 1 0 0 1	64/32	D90000-D9FFFF	6C8000-6CFFFF
SA158	1 0 0 1 1 1 0 10	64/32	9E0000-9EFFFF	4F0000-4F7FFF	SA218	1 1 0 1 1 0 1 0	64/32	DA0000-DAFFFF	6D0000-6D7FFF
SA159	1 0 0 1 1 1 0 11	64/32	9F0000-9FFFFF	4F8000-4FFFFF	SA219	1 1 0 1 1 0 1 1	64/32	DB0000-DBFFFF	6D8000-6DFFFF
SA160	1 0 1 0 0 0 0 0	64/32	A00000-A0FFFF	500000-507FFF	SA220	1 1 0 1 1 1 0 0	64/32	DC0000-DCFFFF	6E0000-6E7FFF
SA161	1 0 1 0 0 0 0 1	64/32	A10000-A1FFFF	508000-50FFFF	SA221	1 1 0 1 1 1 0 1	64/32	DD0000-DDFFFF	6E8000-6EFFFF
SA162	1 0 1 0 0 0 0 10	64/32	A20000-A2FFFF	510000-517FFF	SA222	1 1 0 1 1 1 1 0	64/32	DE0000-DEFFFF	6F0000-6F7FFF
SA163	1 0 1 0 0 0 0 11	64/32	A30000-A3FFFF	518000-51FFFF	SA223	1 1 0 1 1 1 1 1	64/32	DF0000-DFFFFF	6F8000-6FFFFF
SA164	1 0 1 0 0 1 0 0	64/32	A40000-A4FFFF	520000-527FFF	SA224	1 1 1 0 0 0 0 0	64/32	E00000-E0FFFF	700000-707FFF
SA165	1 0 1 0 0 1 0 1	64/32	A50000-A5FFFF	528000-52FFFF	SA225	1 1 1 0 0 0 0 1	64/32	E10000-E1FFFF	708000-70FFFF
SA166	1 0 1 0 0 1 0 10	64/32	A60000-A6FFFF	530000-537FFF	SA226	1 1 1 0 0 0 0 10	64/32	E20000-E2FFFF	710000-717FFF
SA167	1 0 1 0 0 1 0 11	64/32	A70000-A7FFFF	538000-53FFFF	SA227	1 1 1 0 0 0 1 1	64/32	E30000-E3FFFF	718000-71FFFF
SA168	1 0 1 0 0 1 0 10	64/32	A80000-A8FFFF	540000-547FFF	SA228	1 1 1 0 0 1 0 0	64/32	E40000-E4FFFF	720000-727FFF
SA169	1 0 1 0 0 1 0 11	64/32	A90000-A9FFFF	548000-54FFFF	SA229	1 1 1 0 0 1 0 1	64/32	E50000-E5FFFF	728000-72FFFF
SA170	1 0 1 0 0 1 1 0	64/32	AA0000-AAFFFF	550000-557FFF	SA230	1 1 1 0 0 1 1 0	64/32	E60000-E6FFFF	730000-737FFF
SA171	1 0 1 0 0 1 1 01	64/32	AB0000-ABFFFF	558000-55FFFF	SA231	1 1 1 0 0 1 1 1	64/32	E70000-E7FFFF	738000-73FFFF
SA172	1 0 1 0 0 1 1 10	64/32	AC0000-ACFFFF	560000-567FFF	SA232	1 1 1 0 1 0 0 0	64/32	E80000-E8FFFF	740000-747FFF
SA173	1 0 1 0 0 1 1 10	64/32	AD0000-ADFFFF	568000-56FFFF	SA233	1 1 1 0 1 0 0 1	64/32	E90000-E9FFFF	748000-74FFFF
SA174	1 0 1 0 0 1 1 11	64/32	AE0000-AEFFFF	570000-577FFF	SA234	1 1 1 0 1 0 1 0	64/32	EA0000-EAFFFF	750000-757FFF
SA175	1 0 1 0 0 1 1 11	64/32	AF0000-AFFFFF	578000-577FFF	SA235	1 1 1 0 1 0 1 1	64/32	EB0000-EBFFFF	758000-75FFFF
SA176	1 0 1 1 0 0 0 0	64/32	B00000-B0FFFF	580000-587FFF	SA236	1 1 1 0 1 1 0 0	64/32	EC0000-ECFFFF	760000-767FFF
SA177	1 0 1 1 0 0 0 1	64/32	B10000-B1FFFF	588000-58FFFF	SA237	1 1 1 0 1 1 0 1	64/32	ED0000-EDFFFF	768000-76FFFF
SA178	1 0 1 1 0 0 0 10	64/32	B20000-B2FFFF	590000-597FFF	SA238	1 1 1 0 1 1 1 0	64/32	EE0000-EEFFFF	770000-777FFF
SA179	1 0 1 1 0 0 0 11	64/32	B30000-B3FFFF	598000-59FFFF	SA239	1 1 1 0 1 1 1 1	64/32	EF0000-EFFFFF	778000-77FFFF
SA180	1 0 1 1 0 1 0 0	64/32	B40000-B4FFFF	5A0000-5A7FFF	SA240	1 1 1 1 0 0 0 0	64/32	F00000-F0FFFF	780000-787FFF
SA181	1 0 1 1 0 1 0 1	64/32	B50000-B5FFFF	5A8000-5AFFFF	SA241	1 1 1 1 0 0 0 1	64/32	F10000-F1FFFF	788000-78FFFF
SA182	1 0 1 1 0 1 0 10	64/32	B60000-B6FFFF	5B0000-5B7FFF	SA242	1 1 1 1 0 0 1 0	64/32	F20000-F2FFFF	790000-797FFF
SA183	1 0 1 1 0 1 0 11	64/32	B70000-B7FFFF	5B8000-5BFFFF	SA243	1 1 1 1 0 1 0 1	64/32	F30000-F3FFFF	798000-79FFFF
SA184	1 0 1 1 0 1 1 0	64/32	B80000-B8FFFF	5C0000-5C7FFF	SA244	1 1 1 1 0 1 0 0	64/32	F40000-F4FFFF	7A0000-7A7FFF
SA185	1 0 1 1 0 1 1 01	64/32	B90000-B9FFFF	5C8000-5CFFFF	SA245	1 1 1 1 0 1 0 1	64/32	F50000-F5FFFF	7A8000-7AFFFF
SA186	1 0 1 1 0 1 1 010	64/32	BA0000-BAFFFF	5D0000-5D7FFF	SA246	1 1 1 1 0 1 1 0	64/32	F60000-F6FFFF	7B0000-7B7FFF
SA187	1 0 1 1 0 1 1 011	64/32	BB0000-BBFFFF	5D8000-5DFFFF	SA247	1 1 1 1 0 1 1 1	64/32	F70000-F7FFFF	7B8000-7BFFFF
SA188	1 0 1 1 1 1 0 0	64/32	BC0000-BCFFFF	5E0000-5E7FFF	SA248	1 1 1 1 1 0 0 0	64/32	F80000-F8FFFF	7C0000-7C7FFF
SA189	1 0 1 1 1 1 0 01	64/32	BD0000-BDFFFF	5E8000-5EFFFF	SA249	1 1 1 1 1 0 0 1	64/32	F90000-F9FFFF	7C8000-7CFFFF
SA190	1 0 1 1 1 1 0 010	64/32	BE0000-BEFFFF	5F0000-5F7FFF	SA250	1 1 1 1 1 0 1 0	64/32	FA0000-FAFFFF	7D0000-7D7FFF
SA191	1 0 1 1 1 1 0 011	64/32	BF0000-BFFFFF	5F8000-5FFFFF	SA251	1 1 1 1 1 0 1 1	64/32	FB0000-FBFFFF	7D8000-7DFFFF
SA192	1 1 0 0 0 0 0 0	64/32	C00000-C0FFFF	600000-607FFF	SA252	1 1 1 1 1 1 0 0	64/32	FC0000-FCFFFF	7E0000-7E7FFF
SA193	1 1 0 0 0 0 0 01	64/32	C10000-C1FFFF	608000-60FFFF	SA253	1 1 1 1 1 1 0 1	64/32	FD0000-FDFFFF	7E8000-7EFFFF
SA194	1 1 0 0 0 0 0 10	64/32	C20000-C2FFFF	610000-617FFF	SA254	1 1 1 1 1 1 1 0	64/32	FE0000-FEFFFF	7F0000-7F7FFF
SA195	1 1 0 0 0 0 0 11	64/32	C30000-C3FFFF	618000-61FFFF	SA255	1 1 1 1 1 1 1 1	64/32	FF0000-FFFFFF	7F8000-7FFFFF

Table 17. S29GL256M Sector Address Table (Sheet 1 of 4)

Sector	A23-A15	Sector Size (KB/Kwords)	8-bit Address Range	16-bit Address Range	Sector	A23-A15	Sector Size (KB/Kwords)	8-bit Address Range	16-bit Address Range
SA0	0000000000	64/32	0000000-000FFFF	000000-007FFF	SA68	0010001000	64/32	0440000-044FFFF	220000-227FFF
SA1	0000000001	64/32	0010000-001FFFF	008000-00FFFF	SA69	0010001001	64/32	0450000-045FFFF	228000-22FFFF
SA2	0000000010	64/32	0020000-002FFFF	010000-017FFF	SA70	0010001010	64/32	0460000-046FFFF	230000-237FFF
SA3	0000000011	64/32	0030000-003FFFF	018000-01FFFF	SA71	0010001011	64/32	0470000-047FFFF	238000-23FFFF
SA4	0000000100	64/32	0040000-004FFFF	020000-027FFF	SA72	0010001000	64/32	0480000-048FFFF	240000-247FFF
SA5	0000000101	64/32	0050000-005FFFF	028000-02FFFF	SA73	0010001001	64/32	0490000-049FFFF	248000-24FFFF
SA6	0000000110	64/32	0060000-006FFFF	030000-037FFF	SA74	0010001010	64/32	04A0000-04AFFFF	250000-257FFF
SA7	0000000111	64/32	0070000-007FFFF	038000-03FFFF	SA75	0010001011	64/32	04B0000-04BFFFF	258000-25FFFF
SA8	0000001000	64/32	0080000-008FFFF	040000-047FFF	SA76	0010001100	64/32	04C0000-04CFFFF	260000-267FFF
SA9	0000001001	64/32	0090000-009FFFF	048000-04FFFF	SA77	0010001101	64/32	04D0000-04DFFFF	268000-26FFFF
SA10	0000001010	64/32	00A0000-00AFFFF	050000-057FFF	SA78	0010001110	64/32	04E0000-04EFFFF	270000-277FFF
SA11	0000001011	64/32	00B0000-00BFFFF	058000-05FFFF	SA79	0010001111	64/32	04F0000-04FFFF	278000-27FFFF
SA12	0000001100	64/32	00C0000-00CFFFF	060000-067FFF	SA80	0010001000	64/32	0500000-050FFFF	280000-287FFF
SA13	0000001101	64/32	00D0000-00DFFFF	068000-06FFFF	SA81	0010001001	64/32	0510000-051FFFF	288000-28FFFF
SA14	0000001110	64/32	00E0000-00EFFFF	070000-077FFF	SA82	0010001010	64/32	0520000-052FFFF	290000-297FFF
SA15	0000001111	64/32	00F0000-00FFFFFF	078000-07FFFF	SA83	0010001011	64/32	0530000-053FFFF	298000-29FFFF
SA16	0000100000	64/32	0100000-010FFFF	080000-087FFF	SA84	0010001000	64/32	0540000-054FFFF	2A0000-2A7FFF
SA17	0000100001	64/32	0110000-011FFFF	088000-08FFFF	SA85	0010001001	64/32	0550000-055FFFF	2A8000-2AFFFF
SA18	0000100010	64/32	0120000-012FFFF	090000-097FFF	SA86	0010001010	64/32	0560000-056FFFF	2B0000-2B7FFF
SA19	0000100011	64/32	0130000-013FFFF	098000-09FFFF	SA87	0010001011	64/32	0570000-057FFFF	2B8000-2BFFFF
SA20	0000100100	64/32	0140000-014FFFF	0A0000-0A7FFF	SA88	0010001100	64/32	0580000-058FFFF	2C0000-2C7FFF
SA21	0000100101	64/32	0150000-015FFFF	0A8000-0AFFFF	SA89	0010001101	64/32	0590000-059FFFF	2C8000-2CFFFF
SA22	0000100110	64/32	0160000-016FFFF	0B0000-0B7FFF	SA90	0010001110	64/32	05A0000-05AFFFF	2D0000-2D7FFF
SA23	0000100111	64/32	0170000-017FFFF	0B8000-0BFFFF	SA91	0010001111	64/32	05B0000-05BFFFF	2D8000-2DFFFF
SA24	0000110000	64/32	0180000-018FFFF	0C0000-0C7FFF	SA92	0010001100	64/32	05C0000-05CFFFF	2E0000-2E7FFF
SA25	0000110001	64/32	0190000-019FFFF	0C8000-0CFFFF	SA93	0010001101	64/32	05D0000-05DFFFF	2E8000-2EFFFF
SA26	0000110010	64/32	01A0000-01AFFFF	0D0000-0D7FFF	SA94	0010001110	64/32	05E0000-05EFFFF	2F0000-2F7FFF
SA27	0000110011	64/32	01B0000-01BFFFF	0D8000-0DFFFF	SA95	0010001111	64/32	05F0000-05FFFFFF	2F8000-2FFFFF
SA28	0000110100	64/32	01C0000-01CFFFF	0E0000-0E7FFF	SA96	0011000000	64/32	0600000-060FFFF	300000-307FFF
SA29	0000110101	64/32	01D0000-01DFFFF	0E8000-0EFFFF	SA97	0011000001	64/32	0610000-061FFFF	308000-30FFFF
SA30	0000110110	64/32	01E0000-01EFFFF	0F0000-0F7FFF	SA98	0011000010	64/32	0620000-062FFFF	310000-317FFF
SA31	0000110111	64/32	01F0000-01FFFFFF	0F8000-0FFFFFF	SA99	0011000011	64/32	0630000-063FFFF	318000-31FFFF
SA32	0001000000	64/32	0200000-020FFFF	100000-107FFF	SA100	0011000100	64/32	0640000-064FFFF	320000-327FFF
SA33	0001000001	64/32	0210000-021FFFF	108000-10FFFF	SA101	0011000101	64/32	0650000-065FFFF	328000-32FFFF
SA34	0001000010	64/32	0220000-022FFFF	110000-117FFF	SA102	0011000110	64/32	0660000-066FFFF	330000-337FFF
SA35	0001000011	64/32	0230000-023FFFF	118000-11FFFF	SA103	0011000111	64/32	0670000-067FFFF	338000-33FFFF
SA36	0001000100	64/32	0240000-024FFFF	120000-127FFF	SA104	0011001000	64/32	0680000-068FFFF	340000-347FFF
SA37	0001000101	64/32	0250000-025FFFF	128000-12FFFF	SA105	0011001001	64/32	0690000-069FFFF	348000-34FFFF
SA38	0001000110	64/32	0260000-026FFFF	130000-137FFF	SA106	0011001010	64/32	06A0000-06AFFFF	350000-357FFF
SA39	0001000111	64/32	0270000-027FFFF	138000-13FFFF	SA107	0011001011	64/32	06B0000-06BFFFF	358000-35FFFF
SA40	0001001000	64/32	0280000-028FFFF	140000-147FFF	SA108	0011001100	64/32	06C0000-06CFFFF	360000-367FFF
SA41	0001001001	64/32	0290000-029FFFF	148000-14FFFF	SA109	0011001101	64/32	06D0000-06DFFFF	368000-36FFFF
SA42	0001001010	64/32	02A0000-02AFFFF	150000-157FFF	SA110	0011001110	64/32	06E0000-06EFFFF	370000-377FFF
SA43	0001001011	64/32	02B0000-02BFFFF	158000-15FFFF	SA111	0011001111	64/32	06F0000-06FFFFFF	378000-37FFFF
SA44	0001001100	64/32	02C0000-02CFFFF	160000-167FFF	SA112	0011000000	64/32	0700000-070FFFF	380000-387FFF
SA45	0001001101	64/32	02D0000-02DFFFF	168000-16FFFF	SA113	0011000001	64/32	0710000-071FFFF	388000-38FFFF
SA46	0001001110	64/32	02E0000-02EFFFF	170000-177FFF	SA114	0011000010	64/32	0720000-072FFFF	390000-397FFF
SA47	0001001111	64/32	02F0000-02FFFFFF	178000-17FFFF	SA115	0011000011	64/32	0730000-073FFFF	398000-39FFFF
SA48	0001100000	64/32	0300000-030FFFF	180000-187FFF	SA116	0011000100	64/32	0740000-074FFFF	3A0000-3A7FFF
SA49	0001100001	64/32	0310000-031FFFF	188000-18FFFF	SA117	0011000101	64/32	0750000-075FFFF	3A8000-3AFFFF
SA50	0001100010	64/32	0320000-032FFFF	190000-197FFF	SA118	0011000110	64/32	0760000-076FFFF	3B0000-3B7FFF
SA51	0001100011	64/32	0330000-033FFFF	198000-19FFFF	SA119	0011000111	64/32	0770000-077FFFF	3B8000-3BFFFF
SA52	0001100100	64/32	0340000-034FFFF	1A0000-1A7FFF	SA120	0011000000	64/32	0780000-078FFFF	3C0000-3C7FFF
SA53	0001100101	64/32	0350000-035FFFF	1A8000-1AFFFF	SA121	0011000001	64/32	0790000-079FFFF	3C8000-3CFFFF
SA54	0001100110	64/32	0360000-036FFFF	1B0000-1B7FFF	SA122	0011000010	64/32	07A0000-07AFFFF	3D0000-3D7FFF
SA55	0001100111	64/32	0370000-037FFFF	1B8000-1BFFFF	SA123	0011000011	64/32	07B0000-07BFFFF	3D8000-3DFFFF
SA56	0001101000	64/32	0380000-038FFFF	1C0000-1C7FFF	SA124	0011000000	64/32	07C0000-07CFFFF	3E0000-3E7FFF
SA57	0001101001	64/32	0390000-039FFFF	1C8000-1CFFFF	SA125	0011000001	64/32	07D0000-07DFFFF	3E8000-3EFFFF
SA58	0001101010	64/32	03A0000-03AFFFF	1D0000-1D7FFF	SA126	0011000010	64/32	07E0000-07EFFFF	3F0000-3F7FFF
SA59	0001101011	64/32	03B0000-03BFFFF	1D8000-1DFFFF	SA127	0011000011	64/32	07F0000-07FFFFFF	3F8000-3FFFFF
SA60	0001101100	64/32	03C0000-03CFFFF	1E0000-1E7FFF	SA128	0100000000	64/32	0800000-080FFFF	400000-407FFF
SA61	0001101101	64/32	03D0000-03DFFFF	1E8000-1EFFFF	SA129	0100000001	64/32	0810000-081FFFF	408000-40FFFF
SA62	0001101110	64/32	03E0000-03EFFFF	1F0000-1F7FFF	SA130	0100000010	64/32	0820000-082FFFF	410000-417FFF
SA63	0001101111	64/32	03F0000-03FFFFFF	1F8000-1FFFFFF	SA131	0100000011	64/32	0830000-083FFFF	418000-41FFFF
SA64	0010000000	64/32	0400000-040FFFF	200000-207FFF	SA132	0100000100	64/32	0840000-084FFFF	420000-427FFF
SA65	0010000001	64/32	0410000-041FFFF	208000-20FFFF	SA133	0100000101	64/32	0850000-085FFFF	428000-42FFFF
SA66	0010000010	64/32	0420000-042FFFF	210000-217FFF	SA134	0100000110	64/32	0860000-086FFFF	430000-437FFF
SA67	0010000011	64/32	0430000-043FFFF	218000-21FFFF	SA135	0100000111	64/32	0870000-087FFFF	438000-43FFFF

Table 17. S29GL256M Sector Address Table (Sheet 2 of 4)

Sector	A23-A15	Sector Size (KB/Kwords)	8-bit Address Range	16-bit Address Range	Sector	A23-A15	Sector Size (KB/Kwords)	8-bit Address Range	16-bit Address Range
SA136	01100011000	64/32	0880000-088FFFF	440000-447FFF	SA204	01110011100	64/32	0CC0000-0CCFFFF	660000-667FFF
SA137	01100011001	64/32	0890000-089FFFF	448000-44FFFF	SA205	01110011101	64/32	0CD0000-0CDFFFF	668000-66FFFF
SA138	01100011010	64/32	08A0000-08AFFFF	450000-457FFF	SA206	01110011110	64/32	0CE0000-0CEFFFF	670000-677FFF
SA139	01100011011	64/32	08B0000-08BFFFF	458000-45FFFF	SA207	01110011111	64/32	0CF0000-0CFFFFF	678000-67FFFF
SA140	01100011100	64/32	08C0000-08CFFFF	460000-467FFF	SA208	01110000000	64/32	0D00000-0D0FFFF	680000-687FFF
SA141	01100011101	64/32	08D0000-08DFFFF	468000-46FFFF	SA209	01110100001	64/32	0D10000-0D1FFFF	688000-68FFFF
SA142	01100011110	64/32	08E0000-08EFFFF	470000-477FFF	SA210	01110100100	64/32	0D20000-0D2FFFF	690000-697FFF
SA143	01100011111	64/32	08F0000-08FFFFF	478000-47FFFF	SA211	01110100101	64/32	0D30000-0D3FFFF	698000-69FFFF
SA144	01100100000	64/32	0900000-090FFFF	480000-487FFF	SA212	01110100100	64/32	0D40000-0D4FFFF	6A0000-6A7FFF
SA145	01100100001	64/32	0910000-091FFFF	488000-48FFFF	SA213	01110100101	64/32	0D50000-0D5FFFF	6A8000-6AFFFF
SA146	01100100010	64/32	0920000-092FFFF	490000-497FFF	SA214	01110100110	64/32	0D60000-0D6FFFF	6B0000-6B7FFF
SA147	01100100011	64/32	0930000-093FFFF	498000-49FFFF	SA215	01110100111	64/32	0D70000-0D7FFFF	6B8000-6BFFFF
SA148	01100100100	64/32	0940000-094FFFF	4A0000-4A7FFF	SA216	01110110000	64/32	0D80000-0D8FFFF	6C0000-6C7FFF
SA149	01100100101	64/32	0950000-095FFFF	4A8000-4AFFFF	SA217	01110110001	64/32	0D90000-0D9FFFF	6C8000-6CFFFF
SA150	01100100110	64/32	0960000-096FFFF	4B0000-4B7FFF	SA218	01110110100	64/32	0DA0000-0DAFFFF	6D0000-6D7FFF
SA151	01100100111	64/32	0970000-097FFFF	4B8000-4BFFFF	SA219	01110110101	64/32	0DB0000-0DBFFFF	6D8000-6DFFFF
SA152	01100110000	64/32	0980000-098FFFF	4C0000-4C7FFF	SA220	01110111000	64/32	0DC0000-0DCFFFF	6E0000-6E7FFF
SA153	01100110001	64/32	0990000-099FFFF	4C8000-4CFFFF	SA221	01110111001	64/32	0DD0000-0DDFFFF	6E8000-6EFFFF
SA154	01100110100	64/32	09A0000-09AFFFF	4D0000-4D7FFF	SA222	01110111100	64/32	0DE0000-0DEFFFF	6F0000-6F7FFF
SA155	01100110101	64/32	09B0000-09BFFFF	4D8000-4DFFFF	SA223	01110111101	64/32	0DF0000-0DFFFFF	6F8000-6FFFFF
SA156	01100110110	64/32	09C0000-09CFFFF	4E0000-4E7FFF	SA224	01110100000	64/32	0E00000-0E0FFFF	700000-707FFF
SA157	01100110111	64/32	09D0000-09DFFFF	4E8000-4EFFFF	SA225	01110100001	64/32	0E10000-0E1FFFF	708000-70FFFF
SA158	01100111000	64/32	09E0000-09EFFFF	4F0000-4F7FFF	SA226	01110100010	64/32	0E20000-0E2FFFF	710000-717FFF
SA159	01100111001	64/32	09F0000-09FFFFF	4F8000-4FFFFF	SA227	01110100011	64/32	0E30000-0E3FFFF	718000-71FFFF
SA160	01101000000	64/32	0A00000-0A0FFFF	500000-507FFF	SA228	01110100100	64/32	0E40000-0E4FFFF	720000-727FFF
SA161	01101000001	64/32	0A10000-0A1FFFF	508000-50FFFF	SA229	01110100101	64/32	0E50000-0E5FFFF	728000-72FFFF
SA162	01101000010	64/32	0A20000-0A2FFFF	510000-517FFF	SA230	01110100110	64/32	0E60000-0E6FFFF	730000-737FFF
SA163	01101000011	64/32	0A30000-0A3FFFF	518000-51FFFF	SA231	01110100111	64/32	0E70000-0E7FFFF	738000-73FFFF
SA164	01101000100	64/32	0A40000-0A4FFFF	520000-527FFF	SA232	01110100100	64/32	0E80000-0E8FFFF	740000-747FFF
SA165	01101000101	64/32	0A50000-0A5FFFF	528000-52FFFF	SA233	01110100101	64/32	0E90000-0E9FFFF	748000-74FFFF
SA166	01101000110	64/32	0A60000-0A6FFFF	530000-537FFF	SA234	01110100101	64/32	0EA0000-0EAFFFF	750000-757FFF
SA167	01101000111	64/32	0A70000-0A7FFFF	538000-53FFFF	SA235	01110100111	64/32	0EB0000-0EBFFFF	758000-75FFFF
SA168	01101001000	64/32	0A80000-0A8FFFF	540000-547FFF	SA236	01110100110	64/32	0EC0000-0ECFFFF	760000-767FFF
SA169	01101001001	64/32	0A90000-0A9FFFF	548000-54FFFF	SA237	01110100101	64/32	0ED0000-0EDFFFF	768000-76FFFF
SA170	01101001010	64/32	0AA0000-0AAFFFF	550000-557FFF	SA238	01110100110	64/32	0EE0000-0EEFFFF	770000-777FFF
SA171	01101001011	64/32	0AB0000-0ABFFFF	558000-55FFFF	SA239	01110100111	64/32	0EF0000-0EFFFFF	778000-77FFFF
SA172	01101010000	64/32	0AC0000-0ACFFFF	560000-567FFF	SA240	01111000000	64/32	0F00000-0F0FFFF	780000-787FFF
SA173	01101010001	64/32	0AD0000-0ADFFFF	568000-56FFFF	SA241	01111000001	64/32	0F10000-0F1FFFF	788000-78FFFF
SA174	01101010010	64/32	0AE0000-0AEFFFF	570000-577FFF	SA242	01111000010	64/32	0F20000-0F2FFFF	790000-797FFF
SA175	01101010011	64/32	0AF0000-0AFFFFF	578000-57FFFF	SA243	01111000011	64/32	0F30000-0F3FFFF	798000-79FFFF
SA176	01101011000	64/32	0B00000-0B0FFFF	580000-587FFF	SA244	01111000100	64/32	0F40000-0F4FFFF	7A0000-7A7FFF
SA177	01101011001	64/32	0B10000-0B1FFFF	588000-58FFFF	SA245	01111000101	64/32	0F50000-0F5FFFF	7A8000-7AFFFF
SA178	01101011010	64/32	0B20000-0B2FFFF	590000-597FFF	SA246	01111000110	64/32	0F60000-0F6FFFF	7B0000-7B7FFF
SA179	01101011011	64/32	0B30000-0B3FFFF	598000-59FFFF	SA247	01111000111	64/32	0F70000-0F7FFFF	7B8000-7BFFFF
SA180	01101011100	64/32	0B40000-0B4FFFF	5A0000-5A7FFF	SA248	01111000100	64/32	0F80000-0F8FFFF	7C0000-7C7FFF
SA181	01101011101	64/32	0B50000-0B5FFFF	5A8000-5AFFFF	SA249	01111000101	64/32	0F90000-0F9FFFF	7C8000-7CFFFF
SA182	01101011110	64/32	0B60000-0B6FFFF	5B0000-5B7FFF	SA250	01111000110	64/32	0FA0000-0FAFFFF	7D0000-7D7FFF
SA183	01101011111	64/32	0B70000-0B7FFFF	5B8000-5BFFFF	SA251	01111000101	64/32	0FB0000-0FBFFFF	7D8000-7DFFFF
SA184	01101011100	64/32	0B80000-0B8FFFF	5C0000-5C7FFF	SA252	01111000100	64/32	0FC0000-0FCFFFF	7E0000-7E7FFF
SA185	01101011101	64/32	0B90000-0B9FFFF	5C8000-5CFFFF	SA253	01111000101	64/32	0FD0000-0FDFFFF	7E8000-7EFFFF
SA186	01101011110	64/32	0BA0000-0BAFFFF	5D0000-5D7FFF	SA254	01111000110	64/32	0FE0000-0FEFFFF	7F0000-7F7FFF
SA187	01101011111	64/32	0BB0000-0BBFFFF	5D8000-5DFFFF	SA255	01111000111	64/32	0FF0000-0FFFFFF	7F8000-7FFFFF
SA188	01101100000	64/32	0BC0000-0BCFFFF	5E0000-5E7FFF	SA256	10000000000	64/32	1000000-100FFFF	800000-807FFF
SA189	01101100001	64/32	0BD0000-0BDFFFF	5E8000-5EFFFF	SA257	10000000001	64/32	1010000-101FFFF	808000-80FFFF
SA190	01101100010	64/32	0BE0000-0BEFFFF	5F0000-5F7FFF	SA258	10000000010	64/32	1020000-102FFFF	810000-817FFF
SA191	01101100011	64/32	0BF0000-0BFFFFF	5F8000-5FFFFF	SA259	10000000011	64/32	1030000-103FFFF	818000-81FFFF
SA192	01100000000	64/32	0C00000-0C0FFFF	600000-607FFF	SA260	10000000100	64/32	1040000-104FFFF	820000-827FFF
SA193	01100000001	64/32	0C10000-0C1FFFF	608000-60FFFF	SA261	10000000101	64/32	1050000-105FFFF	828000-82FFFF
SA194	01100000010	64/32	0C20000-0C2FFFF	610000-617FFF	SA262	10000000110	64/32	1060000-106FFFF	830000-837FFF
SA195	01100000011	64/32	0C30000-0C3FFFF	618000-61FFFF	SA263	10000000111	64/32	1070000-107FFFF	838000-83FFFF
SA196	01100001000	64/32	0C40000-0C4FFFF	620000-627FFF	SA264	10000010000	64/32	1080000-108FFFF	840000-847FFF
SA197	01100001001	64/32	0C50000-0C5FFFF	628000-62FFFF	SA265	10000010001	64/32	1090000-109FFFF	848000-84FFFF
SA198	01100001010	64/32	0C60000-0C6FFFF	630000-637FFF	SA266	10000010100	64/32	10A0000-10AFFFF	850000-857FFF
SA199	01100001011	64/32	0C70000-0C7FFFF	638000-63FFFF	SA267	10000010101	64/32	10B0000-10BFFFF	858000-85FFFF
SA200	01100010000	64/32	0C80000-0C8FFFF	640000-647FFF	SA268	10000011000	64/32	10C0000-10CFFFF	860000-867FFF
SA201	01100010001	64/32	0C90000-0C9FFFF	648000-64FFFF	SA269	10000011001	64/32	10D0000-10DFFFF	868000-86FFFF
SA202	01100010010	64/32	0CA0000-0CAFFFF	650000-657FFF	SA270	10000011100	64/32	10E0000-10EFFFF	870000-877FFF
SA203	01100010011	64/32	0CB0000-0CBFFFF	658000-65FFFF	SA271	10000011101	64/32	10F0000-10FFFFF	878000-87FFFF

Table 17. S29GL256M Sector Address Table (Sheet 3 of 4)

Sector	A23-A15	Sector Size (KB/Kwords)	8-bit Address Range	16-bit Address Range	Sector	A23-A15	Sector Size (KB/Kwords)	8-bit Address Range	16-bit Address Range
SA272	11000110000	64/32	1100000-110FFFF	880000-887FFF	SA340	11010101000	64/32	1540000-154FFFF	AA0000-AA7FFF
SA273	11000110001	64/32	1110000-111FFFF	888000-88FFFF	SA341	11010101001	64/32	1550000-155FFFF	AA8000-AAFFFF
SA274	11000110010	64/32	1120000-112FFFF	890000-897FFF	SA342	11010101010	64/32	1560000-156FFFF	AB0000-AB7FFF
SA275	11000110011	64/32	1130000-113FFFF	898000-89FFFF	SA343	11010101011	64/32	1570000-157FFFF	AB8000-ABFFFF
SA276	11000110100	64/32	1140000-114FFFF	8A0000-8A7FFF	SA344	11010101000	64/32	1580000-158FFFF	AC0000-AC7FFF
SA277	11000110101	64/32	1150000-115FFFF	8A8000-8AFFFF	SA345	11010101001	64/32	1590000-159FFFF	AC8000-ACFFFF
SA278	11000110110	64/32	1160000-116FFFF	8B0000-8B7FFF	SA346	11010101010	64/32	15A0000-15AFFFF	AD0000-AD7FFF
SA279	11000110111	64/32	1170000-117FFFF	8B8000-8BFFFF	SA347	11010101011	64/32	15B0000-15BFFFF	AD8000-ADFFFF
SA280	11000111000	64/32	1180000-118FFFF	8C0000-8C7FFF	SA348	11010111000	64/32	15C0000-15CFFFF	AE0000-AE7FFF
SA281	11000111001	64/32	1190000-119FFFF	8C8000-8CFFFF	SA349	11010111001	64/32	15D0000-15DFFFF	AE8000-AEFFFF
SA282	11000111010	64/32	11A0000-11AFFFF	8D0000-8D7FFF	SA350	11010111010	64/32	15E0000-15EFFFF	AF0000-AF7FFF
SA283	11000111011	64/32	11B0000-11BFFFF	8D8000-8DFFFF	SA351	11010111011	64/32	15F0000-15FFFF	AF8000-AFFFF
SA284	11000111100	64/32	11C0000-11CFFFF	8E0000-8E7FFF	SA352	11011000000	64/32	1600000-160FFFF	B00000-B07FFF
SA285	11000111101	64/32	11D0000-11DFFFF	8E8000-8EFFFF	SA353	11011000001	64/32	1610000-161FFFF	B08000-B0FFFF
SA286	11000111110	64/32	11E0000-11EFFFF	8F0000-8F7FFF	SA354	11011000010	64/32	1620000-162FFFF	B10000-B17FFF
SA287	11000111111	64/32	11F0000-11FFFF	8F8000-8FFFF	SA355	11011000011	64/32	1630000-163FFFF	B18000-B1FFFF
SA288	11001000000	64/32	1200000-120FFFF	900000-907FFF	SA356	11011001000	64/32	1640000-164FFFF	B20000-B27FFF
SA289	11001000001	64/32	1210000-121FFFF	908000-90FFFF	SA357	11011001001	64/32	1650000-165FFFF	B28000-B2FFFF
SA290	11001000010	64/32	1220000-122FFFF	910000-917FFF	SA358	11011001010	64/32	1660000-166FFFF	B30000-B37FFF
SA291	11001000011	64/32	1230000-123FFFF	918000-91FFFF	SA359	11011001011	64/32	1670000-167FFFF	B38000-B3FFFF
SA292	11001001000	64/32	1240000-124FFFF	920000-927FFF	SA360	11011010000	64/32	1680000-168FFFF	B40000-B47FFF
SA293	11001001001	64/32	1250000-125FFFF	928000-92FFFF	SA361	11011010001	64/32	1690000-169FFFF	B48000-B4FFFF
SA294	11001001010	64/32	1260000-126FFFF	930000-937FFF	SA362	11011010010	64/32	16A0000-16AFFFF	B50000-B57FFF
SA295	11001001011	64/32	1270000-127FFFF	938000-93FFFF	SA363	11011010011	64/32	16B0000-16BFFFF	B58000-B5FFFF
SA296	11001010000	64/32	1280000-128FFFF	940000-947FFF	SA364	11011011000	64/32	16C0000-16CFFFF	B60000-B67FFF
SA297	11001010001	64/32	1290000-129FFFF	948000-94FFFF	SA365	11011011001	64/32	16D0000-16DFFFF	B68000-B6FFFF
SA298	11001010010	64/32	12A0000-12AFFFF	950000-957FFF	SA366	11011011010	64/32	16E0000-16EFFFF	B70000-B77FFF
SA299	11001010011	64/32	12B0000-12BFFFF	958000-95FFFF	SA367	11011011011	64/32	16F0000-16FFFF	B78000-B7FFFF
SA300	11001011000	64/32	12C0000-12CFFFF	960000-967FFF	SA368	11011100000	64/32	1700000-170FFFF	B80000-B87FFF
SA301	11001011001	64/32	12D0000-12DFFFF	968000-96FFFF	SA369	11011100001	64/32	1710000-171FFFF	B88000-B8FFFF
SA302	11001011010	64/32	12E0000-12EFFFF	970000-977FFF	SA370	11011100010	64/32	1720000-172FFFF	B90000-B97FFF
SA303	11001011011	64/32	12F0000-12FFFF	978000-97FFFF	SA371	11011100011	64/32	1730000-173FFFF	B98000-B9FFFF
SA304	11001100000	64/32	1300000-130FFFF	980000-987FFF	SA372	11011101000	64/32	1740000-174FFFF	BA0000-BA7FFF
SA305	11001100001	64/32	1310000-131FFFF	988000-98FFFF	SA373	11011101001	64/32	1750000-175FFFF	BA8000-BAFFFF
SA306	11001100010	64/32	1320000-132FFFF	990000-997FFF	SA374	11011101010	64/32	1760000-176FFFF	BB0000-BB7FFF
SA307	11001100011	64/32	1330000-133FFFF	998000-99FFFF	SA375	11011101011	64/32	1770000-177FFFF	BB8000-BBFFFF
SA308	11001101000	64/32	1340000-134FFFF	9A0000-9A7FFF	SA376	11011101000	64/32	1780000-178FFFF	BC0000-BC7FFF
SA309	11001101001	64/32	1350000-135FFFF	9A8000-9AFFFF	SA377	11011101001	64/32	1790000-179FFFF	BC8000-BCFFFF
SA310	11001101010	64/32	1360000-136FFFF	9B0000-9B7FFF	SA378	11011101010	64/32	17A0000-17AFFFF	BD0000-BD7FFF
SA311	11001101011	64/32	1370000-137FFFF	9B8000-9BFFFF	SA379	11011101011	64/32	17B0000-17BFFFF	BD8000-BDFFFF
SA312	11001110000	64/32	1380000-138FFFF	9C0000-9C7FFF	SA380	11011110000	64/32	17C0000-17CFFFF	BE0000-BE7FFF
SA313	11001110001	64/32	1390000-139FFFF	9C8000-9CFFFF	SA381	11011110001	64/32	17D0000-17DFFFF	BE8000-BEFFFF
SA314	11001110010	64/32	13A0000-13AFFFF	9D0000-9D7FFF	SA382	11011110010	64/32	17E0000-17EFFFF	BF0000-BF7FFF
SA315	11001110011	64/32	13B0000-13BFFFF	9D8000-9DFFFF	SA383	11011110011	64/32	17F0000-17FFFF	BF8000-BFFFF
SA316	11001110100	64/32	13C0000-13CFFFF	9E0000-9E7FFF	SA384	11000000000	64/32	1800000-180FFFF	C00000-C07FFF
SA317	11001110101	64/32	13D0000-13DFFFF	9E8000-9EFFFF	SA385	11000000001	64/32	1810000-181FFFF	C08000-C0FFFF
SA318	11001110110	64/32	13E0000-13EFFFF	9F0000-9F7FFF	SA386	11000000000	64/32	1820000-182FFFF	C10000-C17FFF
SA319	11001110111	64/32	13F0000-13FFFF	9F8000-9FFFF	SA387	11000000001	64/32	1830000-183FFFF	C18000-C1FFFF
SA320	11010000000	64/32	1400000-140FFFF	A00000-A07FFF	SA388	11000000000	64/32	1840000-184FFFF	C20000-C27FFF
SA321	11010000001	64/32	1410000-141FFFF	A08000-A0FFFF	SA389	11000000001	64/32	1850000-185FFFF	C28000-C2FFFF
SA322	11010000010	64/32	1420000-142FFFF	A10000-A17FFF	SA390	11000000010	64/32	1860000-186FFFF	C30000-C37FFF
SA323	11010000011	64/32	1430000-143FFFF	A18000-A1FFFF	SA391	11000000011	64/32	1870000-187FFFF	C38000-C3FFFF
SA324	11010000100	64/32	1440000-144FFFF	A20000-A27FFF	SA392	11000000000	64/32	1880000-188FFFF	C40000-C47FFF
SA325	11010000101	64/32	1450000-145FFFF	A28000-A2FFFF	SA393	11000000001	64/32	1890000-189FFFF	C48000-C4FFFF
SA326	11010000110	64/32	1460000-146FFFF	A30000-A37FFF	SA394	11000000010	64/32	18A0000-18AFFFF	C50000-C57FFF
SA327	11010000111	64/32	1470000-147FFFF	A38000-A3FFFF	SA395	11000000011	64/32	18B0000-18BFFFF	C58000-C5FFFF
SA328	11010010000	64/32	1480000-148FFFF	A40000-A47FFF	SA396	11000000000	64/32	18C0000-18CFFFF	C60000-C67FFF
SA329	11010010001	64/32	1490000-149FFFF	A48000-A4FFFF	SA397	11000000001	64/32	18D0000-18DFFFF	C68000-C6FFFF
SA330	11010010010	64/32	14A0000-14AFFFF	A50000-A57FFF	SA398	11000000000	64/32	18E0000-18EFFFF	C70000-C77FFF
SA331	11010010011	64/32	14B0000-14BFFFF	A58000-A5FFFF	SA399	11000000001	64/32	18F0000-18FFFF	C78000-C7FFFF
SA332	11010010100	64/32	14C0000-14CFFFF	A60000-A67FFF	SA400	11000000000	64/32	1900000-190FFFF	C80000-C87FFF
SA333	11010010101	64/32	14D0000-14DFFFF	A68000-A6FFFF	SA401	11000000001	64/32	1910000-191FFFF	C88000-C8FFFF
SA334	11010010110	64/32	14E0000-14EFFFF	A70000-A77FFF	SA402	11000000000	64/32	1920000-192FFFF	C90000-C97FFF
SA335	11010010111	64/32	14F0000-14FFFF	A78000-A7FFFF	SA403	11000000001	64/32	1930000-193FFFF	C98000-C9FFFF
SA336	11010100000	64/32	1500000-150FFFF	A80000-A87FFF	SA404	11000000000	64/32	1940000-194FFFF	CA0000-CA7FFF
SA337	11010100001	64/32	1510000-151FFFF	A88000-A8FFFF	SA405	11000000001	64/32	1950000-195FFFF	CA8000-CAFFFF
SA338	11010100010	64/32	1520000-152FFFF	A90000-A97FFF	SA406	11000000000	64/32	1960000-196FFFF	CB0000-CB7FFF
SA339	11010100011	64/32	1530000-153FFFF	A98000-A9FFFF	SA407	11000000001	64/32	1970000-197FFFF	CB8000-CBFFFF

Table 17. S29GL256M Sector Address Table (Sheet 4 of 4)

Sector	A23-A15	Sector Size (KB/Kwords)	8-bit Address Range	16-bit Address Range	Sector	A23-A15	Sector Size (KB/Kwords)	8-bit Address Range	16-bit Address Range
SA408	11100111000	64/32	1980000-198FFFF	CC0000-CC7FFF	SA460	11100111000	64/32	1CC0000-1CCFFFF	E60000-E67FFF
SA409	11100111001	64/32	1990000-199FFFF	CC8000-CCFFFF	SA461	11100111001	64/32	1CD0000-1CDFFFF	E68000-E6FFFF
SA410	11100111010	64/32	19A0000-19AFFFF	CD0000-CD7FFF	SA462	11100111010	64/32	1CE0000-1CEFFFF	E70000-E77FFF
SA411	11100111011	64/32	19B0000-19BFFFF	CD8000-CDFFFF	SA463	11100111011	64/32	1CF0000-1CFFFFF	E78000-E7FFFF
SA412	11100111100	64/32	19C0000-19CFFFF	CE0000-CE7FFF	SA464	11101000000	64/32	1D00000-1D0FFFF	E80000-E87FFF
SA413	11100111101	64/32	19D0000-19DFFFF	CE8000-CEFFFF	SA465	11101000001	64/32	1D10000-1D1FFFF	E88000-E8FFFF
SA414	11100111110	64/32	19E0000-19EFFFF	CF0000-CF7FFF	SA466	11101000010	64/32	1D20000-1D2FFFF	E90000-E97FFF
SA415	11100111111	64/32	19F0000-19FFFFF	CF8000-CFFFFF	SA467	11101000011	64/32	1D30000-1D3FFFF	E98000-E9FFFF
SA416	11101000000	64/32	1A00000-1A0FFFF	D00000-D07FFF	SA468	11101010000	64/32	1D40000-1D4FFFF	EA0000-EA7FFF
SA417	11101000001	64/32	1A10000-1A1FFFF	D08000-D0FFFF	SA469	11101010001	64/32	1D50000-1D5FFFF	EA8000-EAFFFF
SA418	11101000010	64/32	1A20000-1A2FFFF	D10000-D17FFF	SA470	11101010010	64/32	1D60000-1D6FFFF	EB0000-EB7FFF
SA419	11101000011	64/32	1A30000-1A3FFFF	D18000-D1FFFF	SA471	11101010011	64/32	1D70000-1D7FFFF	EB8000-EBFFFF
SA420	11101000100	64/32	1A40000-1A4FFFF	D20000-D27FFF	SA472	11101010000	64/32	1D80000-1D8FFFF	EC0000-EC7FFF
SA421	11101000101	64/32	1A50000-1A5FFFF	D28000-D2FFFF	SA473	11101010001	64/32	1D90000-1D9FFFF	EC8000-ECFFFF
SA422	11101000110	64/32	1A60000-1A6FFFF	D30000-D37FFF	SA474	11101010010	64/32	1DA0000-1DAFFFF	ED0000-ED7FFF
SA423	11101000111	64/32	1A70000-1A7FFFF	D38000-D3FFFF	SA475	11101010011	64/32	1DB0000-1DBFFFF	ED8000-EDFFFF
SA424	11101010000	64/32	1A80000-1A8FFFF	D40000-D47FFF	SA476	11101011000	64/32	1DC0000-1DCFFFF	EE0000-EE7FFF
SA425	11101010001	64/32	1A90000-1A9FFFF	D48000-D4FFFF	SA477	11101011001	64/32	1DD0000-1DDFFFF	EE8000-EEFFFF
SA426	11101010010	64/32	1AA0000-1AAFFFF	D50000-D57FFF	SA478	11101011010	64/32	1DE0000-1DEFFFF	EF0000-EF7FFF
SA427	11101010011	64/32	1AB0000-1ABFFFF	D58000-D5FFFF	SA479	11101011011	64/32	1DF0000-1DFFFFF	EF8000-EFFFFF
SA428	11101011000	64/32	1AC0000-1ACFFFF	D60000-D67FFF	SA480	11110000000	64/32	1E00000-1E0FFFF	F00000-F07FFF
SA429	11101011001	64/32	1AD0000-1ADFFFF	D68000-D6FFFF	SA481	11110000001	64/32	1E10000-1E1FFFF	F08000-F0FFFF
SA430	11101011010	64/32	1AE0000-1AEFFFF	D70000-D77FFF	SA482	11110000010	64/32	1E20000-1E2FFFF	F10000-F17FFF
SA431	11101011011	64/32	1AF0000-1AFFFFF	D78000-D7FFFF	SA483	11110000011	64/32	1E30000-1E3FFFF	F18000-F1FFFF
SA432	11101100000	64/32	1B00000-1B0FFFF	D80000-D87FFF	SA484	11110000100	64/32	1E40000-1E4FFFF	F20000-F27FFF
SA433	11101100001	64/32	1B10000-1B1FFFF	D88000-D8FFFF	SA485	11110000101	64/32	1E50000-1E5FFFF	F28000-F2FFFF
SA434	11101100010	64/32	1B20000-1B2FFFF	D90000-D97FFF	SA486	11110000110	64/32	1E60000-1E6FFFF	F30000-F37FFF
SA435	11101100011	64/32	1B30000-1B3FFFF	D98000-D9FFFF	SA487	11110000111	64/32	1E70000-1E7FFFF	F38000-F3FFFF
SA436	11101101000	64/32	1B40000-1B4FFFF	DA0000-DA7FFF	SA488	11110001000	64/32	1E80000-1E8FFFF	F40000-F47FFF
SA437	11101101001	64/32	1B50000-1B5FFFF	DA8000-DAFFFF	SA489	11110001001	64/32	1E90000-1E9FFFF	F48000-F4FFFF
SA438	11101101010	64/32	1B60000-1B6FFFF	DB0000-DB7FFF	SA490	11110001010	64/32	1EA0000-1EAFFFF	F50000-F57FFF
SA439	11101101011	64/32	1B70000-1B7FFFF	DB8000-DBFFFF	SA491	11110001011	64/32	1EB0000-1EBFFFF	F58000-F5FFFF
SA440	11101101000	64/32	1B80000-1B8FFFF	DC0000-DC7FFF	SA492	11110001100	64/32	1EC0000-1ECFFFF	F60000-F67FFF
SA441	11101101001	64/32	1B90000-1B9FFFF	DC8000-DCFFFF	SA493	11110001101	64/32	1ED0000-1EDFFFF	F68000-F6FFFF
SA442	11101101010	64/32	1BA0000-1BAFFFF	DD0000-DD7FFF	SA494	11110001110	64/32	1EE0000-1EEFFFF	F70000-F77FFF
SA443	11101101011	64/32	1BB0000-1BBFFFF	DD8000-DDFFFF	SA495	11110001111	64/32	1EF0000-1EFFFFF	F78000-F7FFFF
SA444	11101110000	64/32	1BC0000-1BCFFFF	DE0000-DE7FFF	SA496	11111000000	64/32	1F00000-1F0FFFF	F80000-F87FFF
SA445	11101110001	64/32	1BD0000-1BDFFFF	DE8000-DEFFFF	SA497	11111000001	64/32	1F10000-1F1FFFF	F88000-F8FFFF
SA446	11101110010	64/32	1BE0000-1BEFFFF	DF0000-DF7FFF	SA498	11111000010	64/32	1F20000-1F2FFFF	F90000-F97FFF
SA447	11101110011	64/32	1BF0000-1BFFFFF	DF8000-DFFFFF	SA499	11111000011	64/32	1F30000-1F3FFFF	F98000-F9FFFF
SA448	11110000000	64/32	1C00000-1C0FFFF	E00000-E07FFF	SA500	11111000100	64/32	1F40000-1F4FFFF	FA0000-FA7FFF
SA449	11110000001	64/32	1C10000-1C1FFFF	E08000-E0FFFF	SA501	11111000101	64/32	1F50000-1F5FFFF	FA8000-FAFFFF
SA450	11110000010	64/32	1C20000-1C2FFFF	E10000-E17FFF	SA502	11111000110	64/32	1F60000-1F6FFFF	FB0000-FB7FFF
SA451	11110000011	64/32	1C30000-1C3FFFF	E18000-E1FFFF	SA503	11111000111	64/32	1F70000-1F7FFFF	FB8000-FBFFFF
SA452	11110000100	64/32	1C40000-1C4FFFF	E20000-E27FFF	SA504	11111000100	64/32	1F80000-1F8FFFF	FC0000-FC7FFF
SA453	11110000101	64/32	1C50000-1C5FFFF	E28000-E2FFFF	SA505	11111000101	64/32	1F90000-1F9FFFF	FC8000-FCFFFF
SA454	11110000110	64/32	1C60000-1C6FFFF	E30000-E37FFF	SA506	11111000110	64/32	1FA0000-1FAFFFF	FD0000-FD7FFF
SA455	11110000111	64/32	1C70000-1C7FFFF	E38000-E3FFFF	SA507	11111000101	64/32	1FB0000-1FBFFFF	FD8000-FDFFFF
SA456	11110001000	64/32	1C80000-1C8FFFF	E40000-E47FFF	SA508	11111000100	64/32	1FC0000-1FCFFFF	FE0000-FE7FFF
SA457	11110001001	64/32	1C90000-1C9FFFF	E48000-E4FFFF	SA509	11111000101	64/32	1FD0000-1FDFFFF	FE8000-FEFFFF
SA458	11110001010	64/32	1CA0000-1CAFFFF	E50000-E57FFF	SA510	11111000110	64/32	1FE0000-1FEFFFF	FF0000-FF7FFF
SA459	11110001011	64/32	1CB0000-1CBFFFF	E58000-E5FFFF	SA511	11111000111	64/32	1FF0000-1FFFFFF	FF8000-FFFFFF

Autoselect Mode

The autoselect mode provides manufacturer and device identification, and sector group protection verification, through identifier codes output on DQ7–DQ0. This mode is primarily intended for programming equipment to automatically match a device to be programmed with its corresponding programming algorithm. However, the autoselect codes can also be accessed in-system through the command register.

When using programming equipment, the autoselect mode requires V_{ID} on address pin A9. Address pins A6, A3, A2, A1, and A0 must be as shown in Table 18. In addition, when verifying sector protection, the sector address must appear on the appropriate highest order address bits (see Table 6 through Table 17). Table 18 shows the remaining address bits that are don't care. When all necessary bits are set as required, the programming equipment may then read the corresponding identifier code on DQ7–DQ0.

To access the autoselect codes in-system, the host system can issue the autoselect command via the command register, as shown in Table 35 and Table 36. This method does not require V_{ID} . See [Autoselect Command Sequence](#) for more information.

Table 18. Autoselect Codes, (High Voltage Method)

Description	CE#	OE#	WE#	A22 to A15	A14 to A10	A9	A8 to A7	A6	A5 to A4	A3 to A2	A1	A0	DQ8 to DQ15		DQ7 to DQ0			
													BYTE# = V_{IH}	BYTE# = V_{IL}	Model Number			
															R0	R1, R2, R8, R9	R3,R4	R5, R6, R7
Manufacturer ID: Spansion Products	L	L	H	X	X	V_{ID}	X	L	X	L	L	L	00	X	01h	01h	01h	01h
S29GL256M	L	L	H	X	X	V_{ID}	X	L	X	L	L	H	22	X		7Eh		
										H	H	L	22	X		12h		
										H	H	H	22	X		01h		
S29GL128M	L	L	H	X	X	V_{ID}	X	L	X	L	L	H	22	X		7Eh		
										H	H	L	22	X		12h		
										H	H	H	22	X		00h		
S29GL064M	L	L	H	X	X	V_{ID}	X	L	X	L	L	H	22	X	7Eh	7Eh	7Eh	7Eh
										H	H	L	22	X	13h	0Ch	10h	13h
										H	H	H	22	X	00h	01h	00h (-R4, bottom boot) 01h (-R3, top boot)	01h
S29GL032M	L	L	H	X	X	V_{ID}	X	L	X	L	L	H	22	X	7Eh	7Eh	7Eh	7Eh
										H	H	L	22	X	1Ch	1Dh	1Ah	1Ah
										H	H	H	22	X	00h	00h	00h (-R4, bottom boot) 01h (-R3, top boot)	00h (-R6, bottom boot) 01h (-R5, top boot)
Sector Group Protection Verification	L	L	H	SA	X	V_{ID}	X	L	X	L	H	L	X	X	01h (protected), 00h (unprotected)			
Secured Silicon Sector Indicator Bit (DQ7), WP# protects highest address sector	L	L	H	X	X	V_{ID}	X	L	X	L	H	H	X	X	98h (factory locked), 18h (not factory locked)			
Secured Silicon Sector Indicator Bit (DQ7), WP# protects lowest address sector	L	L	H	X	X	V_{ID}	X	L	X	L	H	H	X	X	88h (factory locked), 08h (not factory locked)			

Legend: L = Logic Low = V_{IL} , H = Logic High = V_{IH} , SA = Sector Address, X = Don't care.

Sector Group Protection and Unprotection

The hardware sector group protection feature disables both program and erase operations in any sector group. In this device, a sector group consists of four adjacent sectors that are protected or unprotected at the same time (see [Table 4](#)). The hardware sector group unprotection feature re-enables both program and erase operations in previously protected sector groups. Sector group protection/unprotection can be implemented via two methods.

Sector protection/unprotection requires V_{DD} on the RESET# pin only, and can be implemented either in-system or via programming equipment. [Figure 2](#) shows the algorithms and [Figure 24](#) shows the timing diagram. This method uses standard microprocessor bus cycle timing. For sector group unprotect, all unprotected sector groups must first be protected prior to the first sector group unprotect write cycle.

The device is shipped with all sector groups unprotected. Spansion offers the option of programming and protecting sector groups at its factory prior to shipping the device through Spansion Programming Service. Contact a Spansion representative for details.

It is possible to determine whether a sector group is protected or unprotected. See [Autoselect Mode](#) for details.

Table 19. S29GL032M (Model R0) Sector Group Protection/Unprotection Addresses

Sector Group	A22–A18	Sector Group	A22–A18	Sector Group	A22–A18	Sector Group	A22–A18
SA0–SA3	00000	SA16–SA19	00100	SA32–SA35	01000	SA48–SA51	01100
SA4–SA7	00001	SA20–SA23	00101	SA36–SA39	01001	SA52–SA55	01101
SA8–SA11	00010	SA24–SA27	00110	SA40–SA43	01010	SA56–SA59	01110
SA12–SA15	00011	SA28–SA31	00111	SA44–SA47	01011	SA60–SA63	01111

Note: All sector groups are 256 Kwords in size.

Table 20. S29GL032M (Models RI, R2) Sector Group Protection/Unprotection Addresses

Sector Group	A20–A15	Sector Group	A20–A15	Sector Group	A20–A15	Sector Group	A20–A15
SA0	000000	SA12–SA15	0011xx	SA36–SA39	1001xx	SA56–SA59	1110xx
SA1	000001	SA16–SA19	0100xx	SA40–SA43	1010xx	SA60	111100
SA2	000010	SA20–SA23	0101xx	SA44–SA47	1011xx	SA61	111101
SA3	000011	SA24–SA27	0110xx	SA48–SA51	1100xx	SA62	111110
SA4–SA7	0001xx	SA28–SA31	0111xx	SA52–SA55	1101xx	SA63	111111
SA8–SA11	0010xx	SA32–SA35	1000xx				

Table 21. S29GL032M (Models R3, R5) Sector Group Protection/Unprotection Address Table

Sector	A20–A12	Sector/Sector Block Size (Kbytes)	Sector	A20–A12	Sector/Sector Block Size (Kbytes)	Sector	A20–A12	Sector/Sector Block Size (Kbytes)
SA0-SA3	0000XXXXXh	256 (4x64)	SA36-SA39	1001XXXXXh	256 (4x64)	SA63	111111000h	8
SA4-SA7	0001XXXXXh	256 (4x64)	SA40-SA43	1010XXXXXh	256 (4x64)	SA64	111111001h	8
SA8-SA11	0010XXXXXh	256 (4x64)	SA44-SA47	1011XXXXXh	256 (4x64)	SA65	111111010h	8
SA12-SA15	0011XXXXXh	256 (4x64)	SA48-SA51	1100XXXXXh	256 (4x64)	SA66	111111011h	8
SA16-SA19	0100XXXXXh	256 (4x64)	SA52-SA55	1101XXXXXh	256 (4x64)	SA67	111111100h	8
SA20-SA23	0101XXXXXh	256 (4x64)	SA56-SA59	1110XXXXXh	256 (4x64)	SA68	111111101h	8
SA24-SA27	0110XXXXXh	256 (4x64)	SA60-SA62	111100XXXh	192 (3x64)	SA69	111111110h	8
SA28-SA31	0111XXXXXh	256 (4x64)		111101XXXh		SA70	111111111h	8
SA32-SA35	1000XXXXXh	256 (4x64)		111110XXXh				

Table 22. S29GL032M (Models R4, R6) Sector Group Protection/Unprotection Address Table

Sector	A20–A12	Sector/Sector Block Size (Kbytes)	Sector	A20–A12	Sector/Sector Block Size (Kbytes)	Sector	A20–A12	
SA0	000000000h	8	SA8–SA10	000001XXXh	192 (3x64)	SA35–SA38	0111XXXXXh	256 (4x64)
SA1	000000001h	8		000010XXXh		SA39–SA42	1000XXXXXh	256 (4x64)
SA2	000000010h	8		000011XXXh		SA43–SA46	1001XXXXXh	256 (4x64)
SA3	000000011h	8	SA11–SA14	0001XXXXXh	256 (4x64)	SA47–SA50	1010XXXXXh	256 (4x64)
SA4	000000100h	8	SA15–SA18	0010XXXXXh	256 (4x64)	SA51–SA54	1011XXXXXh	256 (4x64)
SA5	000000101h	8	SA19–SA22	0011XXXXXh	256 (4x64)	SA55–SA58	1100XXXXXh	256 (4x64)
SA6	000000110h	8	SA23–SA26	0100XXXXXh	256 (4x64)	SA59–SA62	1101XXXXXh	256 (4x64)
SA7	000000111h	8	SA27–SA30	0101XXXXXh	256 (4x64)	SA63–SA66	1110XXXXXh	256 (4x64)
			SA31–SA34	0110XXXXXh	256 (4x64)	SA67–SA70	1111XXXXXh	256 (4x64)

Table 23. S29GL064M (Model 00) Sector Group Protection/Unprotection Address Table

Sector Group	A22–A18	Sector Group	A22–A18	Sector Group	A22–A18	Sector Group	A22–A18
SA0–SA3	00000	SA36–SA39	01001	SA68–SA71	10001	SA100–SA103	11001
SA4–SA7	00001	SA40–SA43	01010	SA72–SA75	10010	SA104–SA107	11010
SA8–SA11	00010	SA44–SA47	01011	SA76–SA79	10011	SA108–SA111	11011
SA12–SA15	00011	SA48–SA51	01100	SA80–SA83	10100	SA112–SA115	11100
SA16–SA19	00100	SA52–SA55	01101	SA88–SA91	10110	SA116–SA119	11101
SA20–SA23	00101	SA56–SA59	01110	SA92–SA95	10111	SA120–SA123	11110
SA24–SA27	00110	SA60–SA63	01111	SA96–SA99	11000	SA124–SA127	11111
SA32–SA35	01000	SA64–SA67	10000				

Note: All sector groups are 256 Kwords in size.

Table 24. S29GL064M (Models R1, R2, R8, R9) Sector Group Protection/Unprotection Addresses

Sector Group	A21–A15	Sector Group	A21–A15	Sector Group	A21–A15	Sector Group	A21–A15
SA0	0000000	SA28–SA31	00111xx	SA64–SA67	10000xx	SA104–SA107	11010xx
SA1	0000001	SA32–SA35	01000xx	SA68–SA71	10001xx	SA108–SA111	11011xx
SA2	0000010	SA36–SA39	01001xx	SA72–SA75	10010xx	SA112–SA115	11100xx
SA3	0000011	SA40–SA43	01010xx	SA76–SA79	10011xx	SA116–SA119	11101xx
SA4–SA7	00001xx	SA44–SA47	01011xx	SA80–SA83	10100xx	SA120–SA123	11110xx
SA8–SA11	00010xx	SA48–SA51	01100xx	SA84–SA87	10101xx	SA124	1111100
SA12–SA15	00011xx	SA52–SA55	01101xx	SA88–SA91	10110xx	SA125	1111101
SA16–SA19	00100xx	SA56–SA59	01110xx	SA92–SA95	10111xx	SA126	1111110
SA20–SA23	00101xx	SA60–SA63	01111xx	SA96–SA99	11000xx	SA127	1111111
SA24–SA27	00110xx	SA28–SA31	00111xx	SA100–SA103	11001xx		

Table 25. S29GL064M (Model R3) Sector Group Protection/Unprotection Address Table

Sector	A21–A12	Sector/ Sector Block Size (Kbytes)	Sector	A21–A12	Sector/ Sector Block Size (Kbytes)	Sector	A21–A12	Sector/ Sector Block Size (Kbytes)
SA0–SA3	00000XXXX	256 (4x64)	SA56–SA59	01110XXXX	256 (4x64)	SA112–SA115	11100XXXX	256 (4x64)
SA4–SA7	00001XXXX	256 (4x64)	SA60–SA63	01111XXXX	256 (4x64)	SA116–SA119	11101XXXX	256 (4x64)
SA8–SA11	00010XXXX	256 (4x64)	SA64–SA67	10000XXXX	256 (4x64)	SA120–SA123	11110XXXX	256 (4x64)
SA12–SA15	00011XXXX	256 (4x64)	SA68–SA71	10001XXXX	256 (4x64)	SA124–SA126	1111100XXX	192 (3x64)
SA16–SA19	00100XXXX	256 (4x64)	SA72–SA75	10010XXXX	256 (4x64)		1111101XXX	
SA20–SA23	00101XXXX	256 (4x64)	SA76–SA79	10011XXXX	256 (4x64)	SA127	1111110000	8
SA24–SA27	00110XXXX	256 (4x64)	SA80–SA83	10100XXXX	256 (4x64)	SA128	1111111001	8
SA28–SA31	00111XXXX	256 (4x64)	SA84–SA87	10101XXXX	256 (4x64)	SA129	1111111010	8
SA32–SA35	01000XXXX	256 (4x64)	SA88–SA91	10110XXXX	256 (4x64)	SA130	1111111011	8
SA36–SA39	01001XXXX	256 (4x64)	SA92–SA95	10111XXXX	256 (4x64)	SA131	1111111100	8
SA40–SA43	01010XXXX	256 (4x64)	SA96–SA99	11000XXXX	256 (4x64)	SA132	1111111101	8
SA44–SA47	01011XXXX	256 (4x64)	SA100–SA103	11001XXXX	256 (4x64)	SA133	1111111110	8
SA48–SA51	01100XXXX	256 (4x64)	SA104–SA107	11010XXXX	256 (4x64)	SA134	1111111111	8
SA52–SA55	01101XXXX	256 (4x64)	SA108–SA111	11011XXXX	256 (4x64)			

Table 26. S29GL064M (Model R4) Sector Group Protection/Unprotection Addresses

Sector	A21-A12	Sector/Sector Block Size (Kbytes)	Sector	A21-A12	Sector/Sector Block Size (Kbytes)	Sector	A21-A12	Sector/Sector Block Size (Kbytes)
SA0	0000000000	8	SA23-SA26	00100XXXXX	256 (4x64)	SA79-SA82	10010XXXXX	256 (4x64)
SA1	0000000001	8	SA27-SA30	00101XXXXX	256 (4x64)	SA83-SA86	10011XXXXX	256 (4x64)
SA2	0000000010	8	SA31-SA34	00110XXXXX	256 (4x64)	SA87-SA90	10100XXXXX	256 (4x64)
SA3	0000000011	8	SA35-SA38	00111XXXXX	256 (4x64)	SA91-SA94	10101XXXXX	256 (4x64)
SA4	0000000100	8	SA39-SA42	01000XXXXX	256 (4x64)	SA95-SA98	10110XXXXX	256 (4x64)
SA5	0000000101	8	SA43-SA46	01001XXXXX	256 (4x64)	SA99-SA102	10111XXXXX	256 (4x64)
SA6	0000000110	8	SA47-SA50	01010XXXXX	256 (4x64)	SA103-SA106	11000XXXXX	256 (4x64)
SA7	0000000111	8	SA51-SA54	01011XXXXX	256 (4x64)	SA107-SA110	11001XXXXX	256 (4x64)
SA8-SA10	0000001XXX	192 (3x64)	SA55-SA58	01100XXXXX	256 (4x64)	SA111-SA114	11010XXXXX	256 (4x64)
	0000010XXX		SA59-SA62	01101XXXXX	256 (4x64)	SA115-SA118	11011XXXXX	256 (4x64)
	0000011XXX		SA63-SA66	01110XXXXX	256 (4x64)	SA119-SA122	11100XXXXX	256 (4x64)
	00001XXXXX		SA67-SA70	01111XXXXX	256 (4x64)	SA123-SA126	11101XXXXX	256 (4x64)
SA11-SA14	00001XXXXX	256 (4x64)	SA71-SA74	10000XXXXX	256 (4x64)	SA127-SA130	11110XXXXX	256 (4x64)
SA15-SA18	00010XXXXX	256 (4x64)	SA75-SA78	10001XXXXX	256 (4x64)	SA131-SA134	11111XXXXX	256 (4x64)
SA19-SA22	00011XXXXX	256 (4x64)						

Table 27. S29GL064M (Model R5) Sector Group Protection/Unprotection Addresses

Sector Group	A21-A17	Sector Group	A21-A17	Sector Group	A21-A17	Sector Group	A21-A17	Sector Group	A21-A17
SA0-SA3	00000	SA28-SA31	00111	SA56-SA59	01110	SA80-SA83	10100	SA104-SA107	11010
SA4-SA7	00001	SA32-SA35	01000	SA60-SA63	01111	SA84-SA87	10101	SA108-SA111	11011
SA8-SA11	00010	SA36-SA39	01001	SA64-SA67	10000	SA88-SA91	10110	SA112-SA115	11100
SA12-SA15	00011	SA40-SA43	01010	SA68-SA71	10001	SA92-SA95	10111	SA116-SA119	11101
SA16-SA19	00100	SA44-SA47	01011	SA72-SA75	10010	SA96-SA99	11000	SA120-SA123	11110
SA20-SA23	00101	SA48-SA51	01100	SA76-SA79	10011	SA100-SA103	11001	SA124-SA127	11111
SA24-SA27	00110	SA52-SA55	01101						

Note: All sector groups are 128 Kwords in size.

Table 28. S29GL064M (Models R6, R7) Sector Group Protection/Unprotection Address

Sector Group	A21-A17	Sector Group	A21-A17	Sector Group	A21-A17	Sector Group	A21-A17	Sector Group	A21-A17
SA0-SA3	00000	SA28-SA31	00111	SA56-SA59	01110	SA80-SA83	10100	SA104-SA107	11010
SA4-SA7	00001	SA32-SA35	01000	SA60-SA63	01111	SA84-SA87	10101	SA108-SA111	11011
SA8-SA11	00010	SA36-SA39	01001	SA64-SA67	10000	SA88-SA91	10110	SA112-SA115	11100
SA12-SA15	00011	SA40-SA43	01010	SA68-SA71	10001	SA92-SA95	10111	SA116-SA119	11101
SA16-SA19	00100	SA44-SA47	01011	SA72-SA75	10010	SA96-SA99	11000	SA120-SA123	11110
SA20-SA23	00101	SA48-SA51	01100	SA76-SA79	10011	SA100-SA103	11001	SA124-SA127	11111
SA24-SA27	00110	SA52-SA55	01101						

Note: All sector groups are 128 Kwords in size.

Table 29. S29GL128M Sector Group Protection/Unprotection Addresses

Sector Group	A22-A15	Sector Group	A22-A15	Sector Group	A22-A15	Sector Group	A22-A15	Sector Group	A22-A15
SA0	00000000	SA44-SA47	001011xx	SA100-SA103	011001xx	SA156-SA159	100111xx	SA212-SA215	110101xx
SA1	00000001	SA48-SA51	001100xx	SA104-SA107	011010xx	SA160-SA163	101000xx	SA216-SA219	110110xx
SA2	00000010	SA52-SA55	001101xx	SA108-SA111	011011xx	SA164-SA167	101001xx	SA220-SA223	110111xx
SA3	00000011	SA56-SA59	001110xx	SA112-SA115	011100xx	SA168-SA171	101010xx	SA224-SA227	111000xx
SA4-SA7	000001xx	SA60-SA63	001111xx	SA116-SA119	011101xx	SA172-SA175	101011xx	SA228-SA231	111001xx
SA8-SA11	000010xx	SA64-SA67	010000xx	SA120-SA123	011110xx	SA176-SA179	101100xx	SA232-SA235	111010xx
SA12-SA15	000011xx	SA68-SA71	010001xx	SA124-SA127	011111xx	SA180-SA183	101101xx	SA236-SA239	111011xx
SA16-SA19	000100xx	SA72-SA75	010010xx	SA128-SA131	100000xx	SA184-SA187	101110xx	SA240-SA243	111100xx
SA20-SA23	000101xx	SA76-SA79	010011xx	SA132-SA135	100001xx	SA188-SA191	101111xx	SA244-SA247	111101xx
SA24-SA27	000110xx	SA80-SA83	010100xx	SA136-SA139	100010xx	SA192-SA195	110000xx	SA248-SA251	111110xx
SA28-SA31	000111xx	SA84-SA87	010101xx	SA140-SA143	100011xx	SA196-SA199	110001xx	SA252	11111100
SA32-SA35	001000xx	SA88-SA91	010110xx	SA144-SA147	100100xx	SA200-SA203	110010xx	SA253	11111101
SA36-SA39	001001xx	SA92-SA95	010111xx	SA148-SA151	100101xx	SA204-SA207	110011xx	SA254	11111110
SA40-SA43	001010xx	SA96-SA99	011000xx	SA152-SA155	100110xx	SA208-SA211	110100xx	SA255	11111111

Table 30. S29GL256M Sector Group Protection/Unprotection Addresses

Sector Group	A23-A15	Sector Group	A23-A15	Sector Group	A23-A15	Sector Group	A23-A15
SA0	00000000	SA124-SA127	0011111xx	SA260-SA263	1000001xx	SA392-SA395	1100010xx
SA1	00000001	SA128-SA131	0100000xx	SA264-SA267	1000010xx	SA396-SA399	1100011xx
SA2	00000010	SA132-SA135	0100001xx	SA268-SA271	1000011xx	SA400-SA403	1100100xx
SA3	00000011	SA136-SA139	0100010xx	SA276-SA279	1000101xx	SA404-SA407	1100101xx
SA4-SA7	0000001xx	SA140-SA143	0100011xx	SA276-SA279	1000101xx	SA408-SA411	1100110xx
SA8-SA11	0000010xx	SA144-SA147	0100100xx	SA280-SA283	1000110xx	SA412-SA415	1100111xx
SA12-SA15	0000011xx	SA148-SA151	0100101xx	SA284-SA287	1000111xx	SA416-SA419	1101000xx
SA16-SA19	0000100xx	SA152-SA155	0100110xx	SA288-SA291	1001000xx	SA420-SA423	1101001xx
SA20-SA23	0000101xx	SA156-SA159	0100111xx	SA292-SA295	1001001xx	SA424-SA427	1101010xx
SA24-SA27	0000110xx	SA160-SA163	0101000xx	SA296-SA299	1001010xx	SA428-SA431	1101011xx
SA28-SA31	0000111xx	SA164-SA167	0101001xx	SA300-SA303	1001011xx	SA432-SA435	1101100xx
SA32-SA35	0001000xx	SA168-SA171	0101010xx	SA304-SA307	1001100xx	SA436-SA439	1101101xx
SA36-SA39	0001001xx	SA172-SA175	0101011xx	SA308-SA311	1001101xx	SA440-SA443	1101110xx
SA40-SA43	0001010xx	SA176-SA179	0101100xx	SA312-SA315	1001110xx	SA444-SA447	1101111xx
SA44-SA47	0001011xx	SA180-SA183	0101101xx	SA316-SA319	1001111xx	SA448-SA451	1110000xx
SA48-SA51	0001100xx	SA184-SA187	0101110xx	SA320-SA323	1010000xx	SA452-SA455	1110001xx
SA52-SA55	0001101xx	SA188-SA191	0101111xx	SA324-SA327	1010001xx	SA456-SA459	1110010xx
SA56-SA59	0001110xx	SA192-SA195	0110000xx	SA328-SA331	1010010xx	SA460-SA463	1110011xx
SA60-SA63	0001111xx	SA196-SA199	0110001xx	SA332-SA335	1010011xx	SA464-SA467	1110100xx
SA64-SA67	0010000xx	SA200-SA203	0110010xx	SA336-SA339	1010100xx	SA468-SA471	1110101xx
SA68-SA71	0010001xx	SA204-SA207	0110011xx	SA340-SA343	1010101xx	SA472-SA475	1110110xx
SA72-SA75	0010010xx	SA208-SA211	0110100xx	SA344-SA347	1010110xx	SA476-SA479	1110111xx
SA76-SA79	0010011xx	SA212-SA215	0110101xx	SA348-SA351	1010111xx	SA480-SA483	1111000xx
SA80-SA83	0010100xx	SA216-SA219	0110110xx	SA352-SA355	1011000xx	SA484-SA487	1111001xx
SA84-SA87	0010101xx	SA220-SA223	0110111xx	SA356-SA359	1011001xx	SA488-SA491	1111010xx
SA88-SA91	0010110xx	SA224-SA227	0111000xx	SA360-SA363	1011010xx	SA492-SA495	1111011xx
SA92-SA95	0010111xx	SA228-SA231	0111001xx	SA364-SA367	1011011xx	SA496-SA499	1111100xx
SA96-SA99	0011000xx	SA232-SA235	0111010xx	SA368-SA371	1011100xx	SA500-SA503	1111101xx
SA100-SA103	0011001xx	SA236-SA239	0111011xx	SA372-SA375	1011101xx	SA504-SA507	1111110xx
SA104-SA107	0011010xx	SA240-SA243	0111100xx	SA376-SA379	1011110xx	SA508	111111100
SA108-SA111	0011011xx	SA244-SA247	0111101xx	SA380-SA383	1011111xx	SA509	111111101
SA112-SA115	0011100xx	SA248-SA251	0111110xx	SA384-SA387	1100000xx	SA510	111111110
SA116-SA119	0011101xx	SA252-SA255	0111111xx	SA388-SA391	1100001xx	SA511	111111111
SA120-SA123	0011110xx	SA256-SA259	1000000xx				

Temporary Sector Group Unprotect

This feature allows temporary unprotection of previously protected sector groups to change data in-system. The Sector Group Unprotect mode is activated by setting the RESET# pin to V_{ID} . During this mode, formerly protected sector groups can be programmed or erased by selecting the sector group addresses. Once V_{ID} is removed from the RESET# pin, all the previously protected sector groups are protected again. For this feature, [Figure 1](#) shows the algorithm, and [Figure 23](#) shows the timing diagrams.

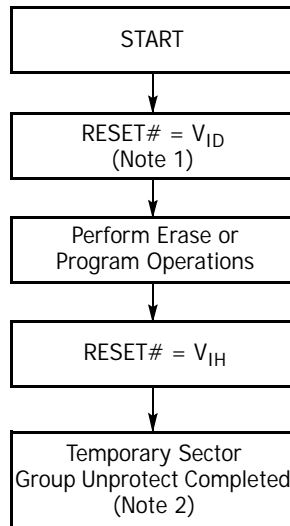

Notes:

1. All protected sector groups unprotected (If WP# = V_{IL} , the highest or lowest address sector remains protected for uniform sector devices, the top or bottom two address sectors remains protected for boot sector devices).
2. All previously protected sector groups are protected once again.

Figure 1. Temporary Sector Group Unprotect Operation

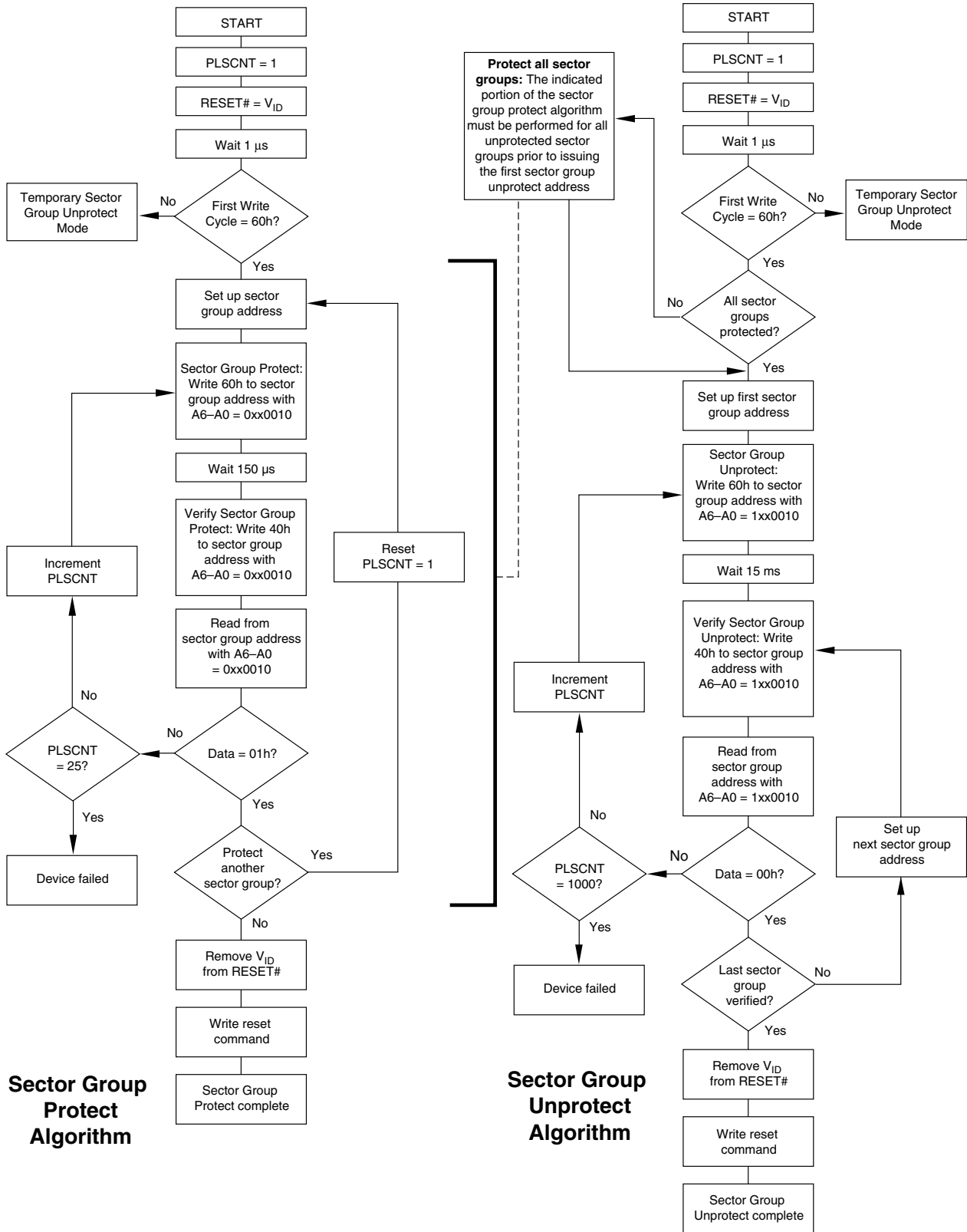

Figure 2. In-System Sector Group Protect/Unprotect Algorithms

Secured Silicon Sector Flash Memory Region

The Secured Silicon Sector feature provides a Flash memory region that enables permanent part identification through an Electronic Serial Number (ESN). The Secured Silicon Sector is 256 bytes in length, and uses a Secured Silicon Sector Indicator Bit (DQ7) to indicate whether or not the Secured Silicon Sector is locked when shipped from the factory. This bit is permanently set at the factory and cannot be changed, which prevents cloning of a factory locked part. This ensures the security of the ESN once the product is shipped to the field.

The factory offers the device with the Secured Silicon Sector either customer lockable (standard shipping option) or factory locked (contact a Spansion sales representative for ordering information). The customer-lockable version is shipped with the Secured Silicon Sector unprotected, allowing customers to program the sector after receiving the device. The customer-lockable version also has the Secured Silicon Sector Indicator Bit permanently set to a "0." The factory-locked version is always protected when shipped from the factory, and has the Secured Silicon (Secured Silicon) Sector Indicator Bit permanently set to a "1." Thus, the Secured Silicon Sector Indicator Bit prevents customer-lockable devices from being used to replace devices that are factory locked.

Note: The ACC function and unlock bypass modes are not available when the Secured Silicon Sector is enabled.

The Secured Silicon sector address space in this device is allocated as follows:

Secured Silicon Sector Address Range		Standard Factory Locked	ExpressFlash Factory Locked	Customer Lockable
x16	x8			
000000h – 000007h	000000h – 00000Fh	ESN	ESN or determined by customer	Determined by customer
000008h – 000007Fh	000010h – 0000FFh	Unavailable	Determined by customer	

The system accesses the Secured Silicon Sector through a command sequence (see [Write Protect \(WP#\)](#)). After the system writes the Enter Secured Silicon Sector command sequence, it may read the Secured Silicon Sector by using the addresses normally occupied by the first sector (SA0). This mode of operation continues until the system issues the Exit Secured Silicon Sector command sequence, or until power is removed from the device. On power-up, or following a hardware reset, the device reverts to sending commands to sector SA0.

Customer Lockable: Secured Silicon Sector *Not* Programmed or Protected At the Factory

Unless otherwise specified, the device is shipped such that the customer may program and protect the 256-byte Secured Silicon sector.

The system may program the Secured Silicon Sector using the write-buffer, accelerated and/or unlock bypass methods, in addition to the standard programming command sequence (see [Command Definitions](#)).

Programming and protecting the Secured Silicon Sector must be used with caution since, once protected, there is no procedure available for unprotecting the Secured Silicon Sector area and none of the bits in the Secured Silicon Sector memory space can be modified in any way.

The Secured Silicon Sector area can be protected using one of the following procedures:

- Write the three-cycle Enter Secured Silicon Sector Region command sequence, and then follow the in-system sector protect algorithm as shown in [Figure 2](#), except that *RESET#* may be at either V_{IH} or V_{ID} . This allows in-system protection of the Secured Silicon Sector without raising any device pin to a high voltage. Note that this method is only applicable to the Secured Silicon Sector.
- Write the three-cycle Enter Secured Silicon Sector Region command sequence and then use the alternate method of sector protection described in the "Sector Group Protection and Un-protection" section.

Once the Secured Silicon Sector is programmed, locked, and verified, the system must write the Exit Secured Silicon Sector Region command sequence to return to reading and writing within the remainder of the array.

Factory Locked: Secured Silicon Sector Programmed and Protected At the Factory

In devices with an ESN, the Secured Silicon Sector is protected when the device is shipped from the factory. The Secured Silicon Sector cannot be modified in any way. An ESN Factory Locked device has an 16-byte random ESN at addresses 000000h–000007h. Please contact your sales representative for details on ordering ESN Factory Locked devices.

Customers may opt to have their code programmed by the factory through the Spansion programming service (Customer Factory Locked). The devices are then shipped from the factory with the Secured Silicon Sector permanently locked. Contact your sales representative for details on using the Spansion programming service.

Write Protect (WP#)

The Write Protect function provides a hardware method of protecting the first or last sector group without using V_{ID} . Write Protect is one of two functions provided by the WP#/ACC input.

If the system asserts V_{IL} on the WP#/ACC pin, the device disables program and erase functions in the first or last sector group independently of whether those sector groups were protected or unprotected. Note that if WP#/ACC is at V_{IL} when the device is in the standby mode, the maximum input load current is increased (Table 30).

Note: If the system asserts V_{IH} on the WP#/ACC pin, the device reverts to whether the first or last sector was previously set to be protected or unprotected using the method described in "Sector Group Protection and Unprotection". Note that WP# has an internal pullup; when unconnected, WP# is at V_{IH} .

Hardware Data Protection

The command sequence requirement of unlock cycles for programming or erasing provides data protection against inadvertent writes (Table 35 and Table 36 contain command definitions). In addition, the following hardware data protection measures prevent accidental erasure or programming, which might otherwise be caused by spurious system level signals during V_{CC} power-up and power-down transitions, or from system noise.

Low V_{CC} Write Inhibit

When V_{CC} is less than V_{LKO} , the device does not accept any write cycles. This protects data during V_{CC} power-up and power-down. The command register and all internal program/erase circuits are disabled, and the device resets to the read mode. Subsequent writes are ignored until V_{CC} is greater than V_{LKO} . The system must provide the proper signals to the control pins to prevent unintentional writes when V_{CC} is greater than V_{LKO} .

Write Pulse "Glitch" Protection

Noise pulses of less than 3 ns (typical) on OE#, CE# or WE# do not initiate a write cycle.

Logical Inhibit

Write cycles are inhibited by holding any one of OE# = V_{IL} , CE# = V_{IH} or WE# = V_{IH} . To initiate a write cycle, CE# and WE# must be a logical zero while OE# is a logical one.

Power-Up Write Inhibit

If WE# = CE# = V_{IL} and OE# = V_{IH} during power up, the device does not accept commands on the rising edge of WE#. The internal state machine is automatically reset to the read mode on power-up.

Common Flash Memory Interface (CFI)

The Common Flash Interface (CFI) specification outlines device and host system software interrogation handshake, which allows specific vendor-specified software algorithms to be used for entire families of devices. Software support can then be device-independent, JEDEC ID-independent, and forward- and backward-compatible for the specified flash device families. Flash vendors can standardize their existing interfaces for long-term compatibility.

This device enters the CFI Query mode when the system writes the CFI Query command, 98h, to address 55h, any time the device is ready to read array data. The system can read CFI information at the addresses given in [Table 31](#) through [Table 34](#). To terminate reading CFI data, the system must write the reset command.

The system can also write the CFI query command when the device is in the autoselect mode. The device enters the CFI query mode, and the system can read CFI data at the addresses given in [Table 31](#) through [Table 34](#). The system must write the reset command to return the device to reading array data.

For further information, please refer to the CFI Specification and CFI Publication 100. Alternatively, contact your sales representative for copies of these documents.

Table 31. CFI Query Identification String

Addresses(x16)	Addresses(x8)	Data	Description
10h 11h 12h	20h 22h 24h	0051h 0052h 0059h	Query Unique ASCII string "QRY"
13h 14h	26h 28h	0002h 0000h	Primary OEM Command Set
15h 16h	2Ah 2Ch	0040h 0000h	Address for Primary Extended Table
17h 18h	2Eh 30h	0000h 0000h	Alternate OEM Command Set (00h = none exists)
19h 1Ah	32h 34h	0000h 0000h	Address for Alternate OEM Extended Table (00h = none exists)

Table 32. System Interface String

Addresses (x16)	Addresses (x8)	Data	Description
1Bh	36h	0027h	V _{CC} Min. (write/erase) D7–D4: volt, D3–D0: 100 millivolt
1Ch	38h	0036h	V _{CC} Max. (write/erase) D7–D4: volt, D3–D0: 100 millivolt
1Dh	3Ah	0000h	V _{PP} Min. voltage (00h = no V _{PP} pin present)
1Eh	3Ch	0000h	V _{PP} Max. voltage (00h = no V _{PP} pin present)
1Fh	3Eh	0007h	Reserved for future use
20h	40h	0007h	Typical timeout for Min. size buffer write 2 ⁿ μs (00h = not supported)
21h	42h	000Ah	Typical timeout per individual block erase 2 ⁿ ms
22h	44h	0000h	Typical timeout for full chip erase 2 ⁿ ms (00h = not supported)
23h	46h	0001h	Reserved for future use
24h	48h	0005h	Max. timeout for buffer write 2 ⁿ times typical
25h	4Ah	0004h	Max. timeout per individual block erase 2 ⁿ times typical
26h	4Ch	0000h	Max. timeout for full chip erase 2 ⁿ times typical (00h = not supported)

Note: CFI data related to VCC and time-outs may differ from actual VCC and time-outs of the product. Please consult the Ordering Information tables to obtain the VCC range for particular part numbers. See the [Erase and Programming Performance](#) table for typical timeout specifications.

Table 33. Device Geometry Definition

Addresses (x16)	Addresses (x8)	Data	Description
27h	4Eh	0019h 0018h 0017h 0016h	Device Size = 2 ⁿ byte 19 = 256 Mb, 18 = 128 Mb, 17 = 64 Mb, 16 = 32 Mb
28h 29h	50h 52h	000xh 0000h	Flash Device Interface description (refer to CFI publication 100) 0000h = x8-only bus devices 0001h = x16-only bus devices 0002h = x8/x16 bus devices
2Ah 2Bh	54h 56h	0005h 0000h	Max. number of byte in multi-byte write = 2 ⁿ (00h = not supported)
2Ch	58h	0001h 0002h	Number of Erase Block Regions within device (01h = uniform device, 02h = boot device)
2Dh 2Eh 2Fh 30h	5Ah 5Ch 5Eh 60h	00xxh 000xh 00x0h 000xh	Erase Block Region 1 Information (refer to the CFI specification or CFI publication 100) 003Fh, 0000h, 0000h, 0001h = 32 Mb (-R0, -R1, -R2, R5, R6) 007Fh, 0000h, 0020h, 0000h = 32 Mb (-R3, -R4), 64 Mb (-R3, -R4) 007Fh, 0000h, 0000h, 0001h = 64 Mb (-R0, -R1, -R2, -R5, -R6, -R7) 00FFh, 0000h, 0000h, 0001h = 128 Mb 00FFh, 0001h, 0000h, 0001h = 256 Mb
31h 32h 33h 34h	60h 64h 66h 68h	00xxh 0000h 0000h 000xh	Erase Block Region 2 Information (refer to CFI publication 100) 003Eh, 0000h, 0000h, 0001h = 32 Mb (-R1, -R2) 007Eh, 0000h, 0000h, 0001h = 64 Mb (-R1, -R2) 0000h, 0000h, 0000h, 0000h = all others
35h 36h 37h 38h	6Ah 6Ch 6Eh 70h	0000h 0000h 0000h 0000h	Erase Block Region 3 Information (refer to CFI publication 100)
39h 3Ah 3Bh 3Ch	72h 74h 76h 78h	0000h 0000h 0000h 0000h	Erase Block Region 4 Information (refer to CFI publication 100)

Table 34. Primary Vendor-Specific Extended Query

Addresses (x16)	Addresses (x8)	Data	Description
40h 41h 42h	80h 82h 84h	0050h 0052h 0049h	Query-unique ASCII string "PRI"
43h	86h	0031h	Major version number, ASCII
44h	88h	0033h	Minor version number, ASCII
45h	8Ah	000xh	Address Sensitive Unlock (Bits 1-0) 0 = Required, 1 = Not Required Process Technology (Bits 7-2) 0010b = 0.23 μm MirrorBit 0009h = x8-only bus devices 0008h = all other devices
46h	8Ch	0002h	Erase Suspend 0 = Not Supported, 1 = To Read Only, 2 = To Read & Write
47h	8Eh	0001h	Sector Protect 0 = Not Supported, X = Number of sectors in per group
48h	90h	0001h	Sector Temporary Unprotect 00 = Not Supported, 01 = Supported
49h	92h	0004h	Sector Protect/Unprotect scheme 0004h = Standard Mode (Refer to Text)
4Ah	94h	0000h	Simultaneous Operation 00 = Not Supported, X = Number of Sectors in Bank
4Bh	96h	0000h	Burst Mode Type 00 = Not Supported, 01 = Supported
4Ch	98h	0001h	Page Mode Type 00 = Not Supported, 01 = 4 Word Page, 02 = 8 Word Page
4Dh	9Ah	00B5h	ACC (Acceleration) Supply Minimum 00h = Not Supported, D7-D4: Volt, D3-D0: 100 mV
4Eh	9Ch	00C5h	ACC (Acceleration) Supply Maximum 00h = Not Supported, D7-D4: Volt, D3-D0: 100 mV
4Fh	9Eh	00xxh	Top/Bottom Boot Sector Flag 00h = Uniform Device without WP# protect, 02h = Bottom Boot Device, 03h = Top Boot Device, 04h = Uniform sectors bottom WP# protect, 05h = Uniform sectors top WP# protect
50h	A0h	0001h	Program Suspend < 00h = Not Supported, 01h = Supported

Command Definitions

Writing specific address and data commands or sequences into the command register initiates device operations. [Table 35](#) and [Table 36](#) define the valid register command sequences. *Writing incorrect address and data values or writing them in the improper sequence may place the device in an unknown state.* A reset command is then required to return the device to reading array data.

All addresses are latched on the falling edge of WE# or CE#, whichever happens later. All data is latched on the rising edge of WE# or CE#, whichever happens first. See [AC Characteristics](#) for timing diagrams.

Reading Array Data

The device is automatically set to reading array data after device power-up. No commands are required to retrieve data. The device is ready to read array data after completing an Embedded Program or Embedded Erase algorithm.

After the device accepts an Erase Suspend command, the device enters the erase-suspend-read mode, after which the system can read data from any non-erase-suspended sector. After completing a programming operation in the Erase Suspend mode, the system may once again read array data with the same exception. See [Erase Suspend/Erase Resume Commands](#) for more information.

The system *must* issue the reset command to return the device to the read (or erase-suspend-read) mode if DQ5 goes high during an active program or erase operation, or if the device is in the autoselect mode. See the next section, Reset Command, for more information.

See also [Requirements for Reading Array Data](#) in the Device Bus Operations section for more information. The Read-Only Operations—[AC Characteristics](#) provides the read parameters, and [Figure 13](#) shows the timing diagram.

Reset Command

Writing the reset command resets the device to the read or erase-suspend-read mode. Address bits are don't cares for this command.

The reset command may be written between the sequence cycles in an erase command sequence before erasing begins. This resets the device to the read mode. Once erasure begins, however, the device ignores reset commands until the operation is complete.

The reset command may be written between the sequence cycles in a program command sequence before programming begins. This resets the device to the read mode. If the program command sequence is written while the device is in the Erase Suspend mode, writing the reset command returns the device to the erase-suspend-read mode. Once programming begins, however, the device ignores reset commands until the operation is complete.

The reset command may be written between the sequence cycles in an autoselect command sequence. Once in the autoselect mode, the reset command must be written to return to the read mode. If the device entered the autoselect mode while in the Erase Suspend mode, writing the reset command returns the device to the erase-suspend-read mode.

If DQ5 goes high during a program or erase operation, writing the reset command returns the device to the read mode (or erase-suspend-read mode if the device was in Erase Suspend).

Note that if DQ1 goes high during a Write Buffer Programming operation, the system must write the Write-to-Buffer-Abort Reset command sequence to reset the device for the next operation.

Autoselect Command Sequence

The autoselect command sequence allows the host system to read several identifier codes at specific addresses:

Identifier Code	A7:A0 (x16)	A6:A-1 (x8)
Manufacturer ID	00h	00h
Device ID, Cycle 1	01h	02h
Device ID, Cycle 2	0Eh	1Ch
Device ID, Cycle 3	0Fh	1Eh
Secured Silicon Sector Factory Protect	03h	06h
Sector Protect Verify	(SA)02h	(SA)04h

Note: 3. The device ID is read over three cycles. SA = Sector Address

The autoselect command sequence is initiated by first writing two unlock cycles. This is followed by a third write cycle that contains the autoselect command. The device then enters the autoselect mode. The system may read at any address any number of times without initiating another autoselect command sequence:

The system must write the reset command to return to the read mode (or erase-suspend-read mode if the device was previously in Erase Suspend).

Enter/Exit Secured Silicon Sector Command Sequence

The Secured Silicon Sector region provides a secured data area containing an 8-word/16-byte random Electronic Serial Number (ESN). The system can access the Secured Silicon Sector region by issuing the three-cycle Enter Secured Silicon Sector command sequence. The device continues to access the Secured Silicon Sector region until the system issues the four-cycle Exit Secured Silicon Sector command sequence. The Exit Secured Silicon Sector command sequence returns the device to normal operation. [Table 35](#) and [Table 36](#) show the address and data requirements for both command sequences. Also, see [Secured Silicon Sector Flash Memory Region](#) for further information. *Note that the ACC function and unlock bypass modes are not available when the Secured Silicon Sector is enabled.*

Word Program Command Sequence

Programming is a four-bus-cycle operation. The program command sequence is initiated by writing two unlock write cycles, followed by the program set-up command. The program address and data are written next, which in turn initiate the Embedded Program algorithm. The system is not required to provide further controls or timings. The device automatically provides internally generated program pulses and verifies the programmed cell margin. [Table 35](#) and [Table 36](#) show the address and data requirements for the word program command sequence, respectively.

When the Embedded Program algorithm is complete, the device then returns to the read mode and addresses are no longer latched. The system can determine the status of the program operation by using DQ7 or DQ6. See [Write Operation Status](#) for information on these status bits. Any commands written to the device during the Embedded Program Algorithm are ignored. *Note that the Secured Silicon Sector, autoselect, and CFI functions are unavailable when a program operation is in progress.* Note that a **hardware reset** immediately terminates the program operation. The program command sequence should be reinitiated once the device returns to the read mode, to ensure data integrity.

Programming is allowed in any sequence of address locations and across sector boundaries. Programming to the same word address multiple times without intervening erases (incremental bit programming) requires a modified programming method. For such application requirements, please contact your local Spansion representative. Word programming is supported for backward compatibility with existing Flash driver software and for occasional writing of individual words. Use of write buffer programming (see below) is strongly recommended for general programming use when more than a few words are to be programmed. The effective word programming time using write buffer programming is approximately four times shorter than the single word programming time.

Any bit in a word cannot be programmed from “0” back to a “1.” Attempting to do so may cause the device to set DQ5=1, or cause DQ7 and DQ6 status bits to indicate the operation was successful. However, a succeeding read shows that the data is still “0.” Only erase operations can convert a “0” to a “1.”

Unlock Bypass Command Sequence

The unlock bypass feature allows the system to program words to the device faster than using the standard program command sequence. The unlock bypass command sequence is initiated by first writing two unlock cycles. This is followed by a third write cycle containing the unlock bypass command, 20h. The device then enters the unlock bypass mode. A two-cycle unlock bypass mode command sequence is all that is required to program in this mode. The first cycle in this sequence contains the unlock bypass program command, A0h; the second cycle contains the program address and data. Additional data is programmed in the same manner. This mode dispenses with the initial two unlock cycles required in the standard program command sequence, resulting in faster total programming time. [Table 35](#) and [Table 36](#) show the requirements for the command sequence.

During the unlock bypass mode, only the Unlock Bypass Program and Unlock Bypass Reset commands are valid. To exit the unlock bypass mode, the system must issue the two-cycle unlock bypass reset command sequence. The first cycle must contain the data 90h. The second cycle must contain the data 00h. The device then returns to the read mode.

Write Buffer Programming

Write Buffer Programming allows the system write to a maximum of 16 words/32 bytes in one programming operation. This results in faster effective programming time than the standard programming algorithms. The Write Buffer Programming command sequence is initiated by first writing two unlock cycles. This is followed by a third write cycle containing the Write Buffer Load command written at the Sector Address in which programming occurs. The fourth cycle writes the sector address and the number of word locations, minus one, to be programmed. For example, if the system programs six unique address locations, then 05h should be written to the device. This tells the device how many write buffer addresses are loaded with data and therefore when to expect the Program Buffer to Flash command. The number of locations to program cannot exceed the size of the write buffer or the operation aborts.

The fifth cycle writes the first address location and data to be programmed. The write-buffer-page is selected by address bits $A_{MAX}-A_4$. All subsequent address/data pairs must fall within the selected-write-buffer-page. The system then writes the remaining address/data pairs into the write buffer. Write buffer locations may be loaded in any order.

The write-buffer-page address must be the same for all address/data pairs loaded into the write buffer. (This means Write Buffer Programming cannot be performed across multiple write-buffer pages.) This also means that Write Buffer Programming cannot be performed across multiple sectors. If the system attempts to load programming data outside of the selected write-buffer page, the operation aborts.

Note that if a Write Buffer address location is loaded multiple times, the address/data pair counter is decremented for every data load operation. The host system must therefore account for loading a write-buffer location more than once. The counter decrements for each data load operation, not for each unique write-buffer-address location. Note also that if an address location is loaded more than once into the buffer, the final data loaded for that address is programmed.

Once the specified number of write buffer locations are loaded, the system must then write the Program Buffer to Flash command at the sector address. Any other address and data combination aborts the Write Buffer Programming operation. The device then begins programming. Data polling should be used while monitoring the last address location loaded into the write buffer. DQ7, DQ6, DQ5, and DQ1 should be monitored to determine the device status during Write Buffer Programming.

The write-buffer programming operation can be suspended using the standard program suspend/resume commands. Upon successful completion of the Write Buffer Programming operation, the device is ready to execute the next command.

The Write Buffer Programming Sequence can be aborted in the following ways:

- Load a value that is greater than the page buffer size during the Number of Locations to Program step.
- Write to an address in a sector different than the one specified during the Write-Buffer-Load command.
- Write an Address/Data pair to a different write-buffer-page than the one selected by the Starting Address during the write buffer data loading stage of the operation.
- Write data other than the Confirm Command after the specified number of data load cycles.

The abort condition is indicated by DQ1 = 1, DQ7 = DATA# (for the last address location loaded), DQ6 = toggle, and DQ5=0. A Write-to-Buffer-Abort Reset command sequence must be written to reset the device for the next operation.

Note that the Secured Silicon Sector, autoselect, and CFI functions are unavailable when a program operation is in progress. This flash device is capable of handling multiple write buffer programming operations on the same write buffer address range without intervening erases. For applications requiring incremental bit programming, a modified programming method is required; please contact your local Spansion representative. **Any bit in a write buffer address range cannot be programmed from "0" back to a "1."** Attempting to do so can cause the device to set DQ5=1, or cause the DQ7 and DQ6 status bits to indicate the operation was successful. However, a succeeding read shows that the data is still "0." Only erase operations can convert a "0" to a "1."

Accelerated Program

The device offers accelerated program operations through the WP#/ACC or ACC pin depending on the particular product. When the system asserts V_{HH} on the WP#/ACC or ACC pin. The device uses the higher voltage on the WP#/ACC or ACC pin to accelerate the operation. *Note that the WP#/ACC pin must not be at V_{HH} for operations other than accelerated programming, or device damage can result. WP# has an internal pullup; when unconnected, WP# is at V_{IH} .*

Figure 3 illustrates the algorithm for the program operation. See [Erase and Program Operations-S29GL032M Only](#) and [AC Characteristics](#) for parameters, and [Figure 14](#) for timing diagrams.

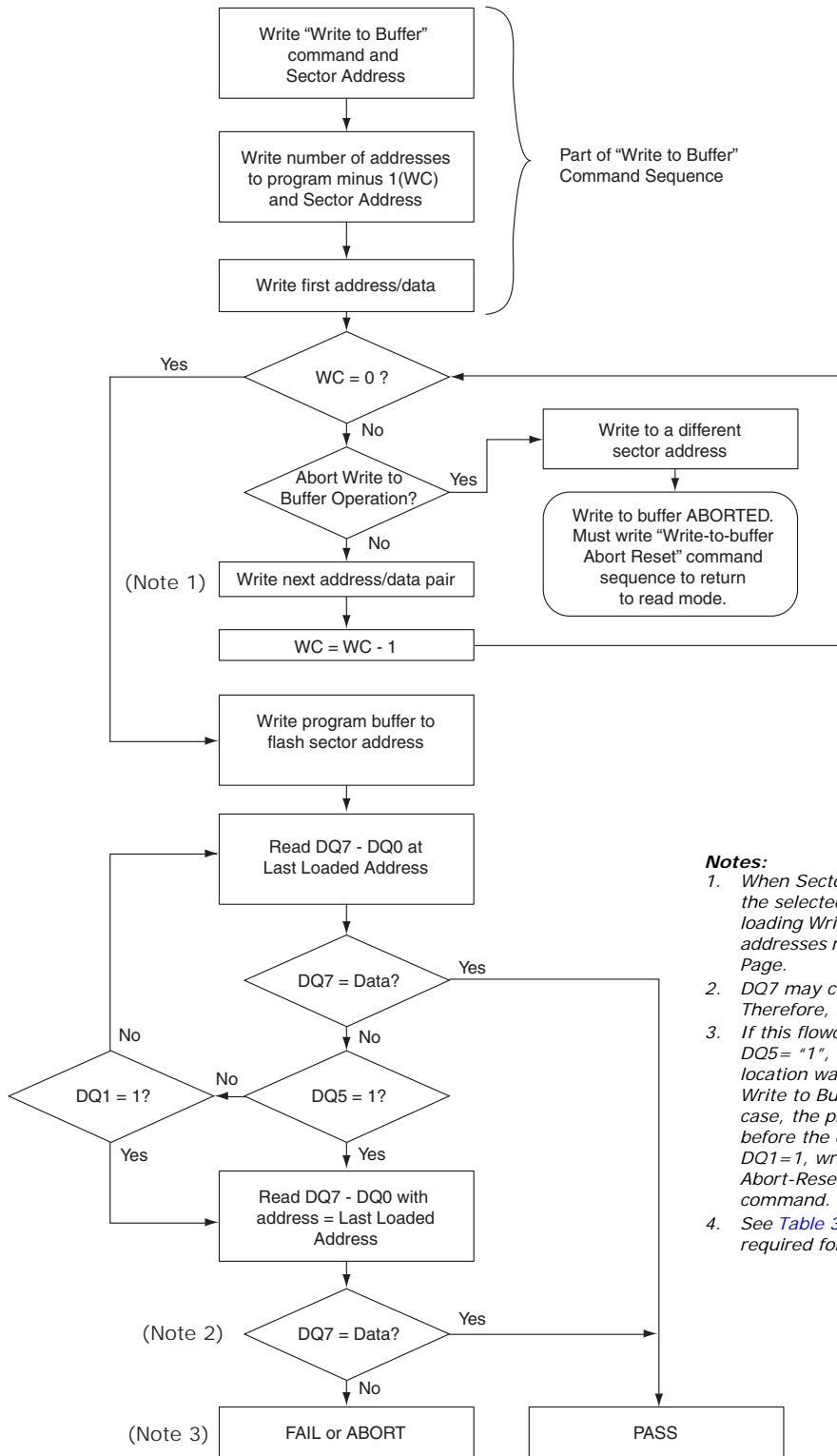

Notes:

1. When Sector Address is specified, any address in the selected sector is acceptable. However, when loading Write-Buffer address locations with data, all addresses must fall within the selected Write-Buffer Page.
2. DQ7 may change simultaneously with DQ5. Therefore, DQ7 should be verified.
3. If this flowchart location was reached because DQ5 = "1", then the device FAILED. If this flowchart location was reached because DQ1 = "1", then the Write to Buffer operation was ABORTED. In either case, the proper reset command must be written before the device can begin another operation. If DQ1=1, write the Write-Buffer-Programming-Abort-Reset command. If DQ5=1, write the Reset command.
4. See [Table 35](#) and [Table 36](#) for command sequences required for write buffer programming.

Figure 3. Write Buffer Programming Operation

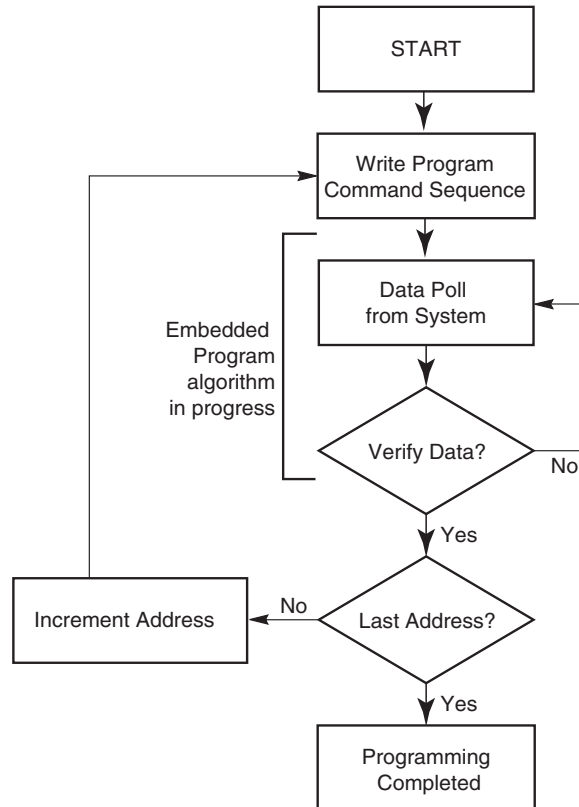

Note: See Table 35 and Table 36 for program command sequence

Figure 4. Program Operation

Program Suspend/Program Resume Command Sequence

The Program Suspend command allows the system to interrupt a programming operation or a Write to Buffer programming operation so that data can be read from any non-suspended sector. When the Program Suspend command is written during a programming process, the device halts the program operation within 15 μs maximum (5 μs typical) and updates the status bits. Addresses are not required when writing the Program Suspend command.

After the programming operation is suspended, the system can read array data from any non-suspended sector. The Program Suspend command can also be issued during a programming operation while an erase is suspended. In this case, data can be read from any addresses not in Erase Suspend or Program Suspend. If a read is needed from the Secured Silicon Sector area (One-time Program area), then user must use the proper command sequences to enter and exit this region. Note that the Secured Silicon Sector, autoselect, and CFI functions are unavailable when a program operation is in progress.

The system can also write the autoselect command sequence when the device is in the Program Suspend mode. The system can read as many autoselect codes as required. When the device exits the autoselect mode, the device reverts to the Program Suspend mode, and is ready for another valid operation. See [Autoselect Command Sequence](#) for more information.

After the Program Resume command is written, the device reverts to programming. The system can determine the status of the program operation using the DQ7 or DQ6 status bits, just as in the standard program operation. See [Write Operation Status](#) for more information.

The system must write the Program Resume command (address bits are don't care) to exit the Program Suspend mode and continue the programming operation. Further writes of the Resume command are ignored. Another Program Suspend command can be written after the device resumes programming.

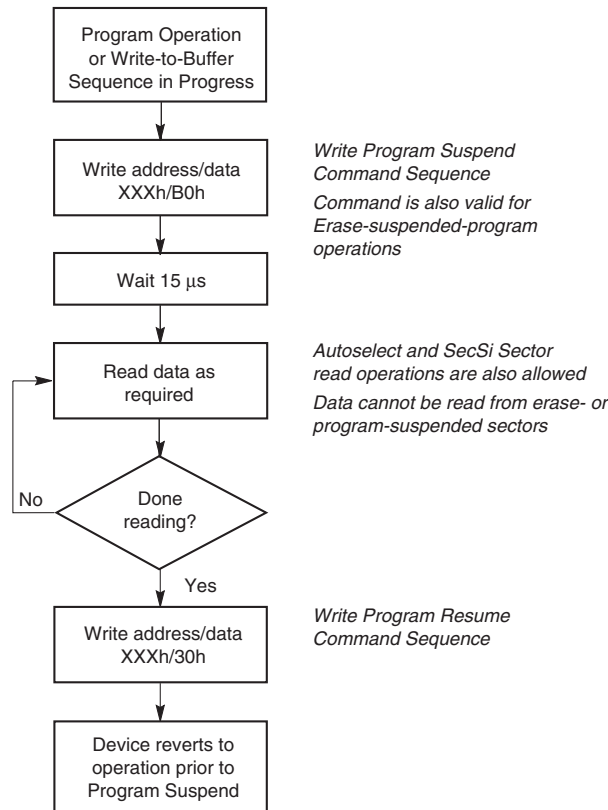

Figure 5. Program Suspend/Program Resume

Chip Erase Command Sequence

Chip erase is a six bus cycle operation. The chip erase command sequence is initiated by writing two unlock cycles, followed by a set-up command. Two additional unlock write cycles are then followed by the chip erase command, which in turn invokes the Embedded Erase algorithm. The device does *not* require the system to preprogram prior to erase. The Embedded Erase algorithm automatically preprograms and verifies the entire memory for an all zero data pattern prior to electrical erase. The system is not required to provide any controls or timings during these operations. [Table 35](#) and [Table 36](#) show the address and data requirements for the chip erase command sequence.

When the Embedded Erase algorithm is complete, the device returns to the read mode and addresses are no longer latched. The system can determine the status of the erase operation by using DQ7, DQ6, or DQ2. See [Write Operation Status](#) for information on these status bits.

Any commands written during the chip erase operation are ignored. However, note that a **hardware reset** immediately terminates the erase operation. If that occurs, the chip erase command sequence should be reinitiated once the device returns to reading array data, to ensure data integrity.

[Figure 6](#) illustrates the algorithm for the erase operation. See [Erase and Programming Performance](#) in [AC Characteristics](#) for parameters, and [Figure 18](#) for timing diagrams.

Sector Erase Command Sequence

Sector erase is a six bus cycle operation. The sector erase command sequence is initiated by writing two unlock cycles, followed by a set-up command. Two additional unlock cycles are written, and are then followed by the address of the sector to be erased, and the sector erase command. [Table 35](#) and [Table 36](#) shows the address and data requirements for the sector erase command sequence.

The device does *not* require the system to preprogram prior to erase. The Embedded Erase algorithm automatically programs and verifies the entire memory for an all zero data pattern prior to electrical erase. The system is not required to provide any controls or timings during these operations.

After the command sequence is written, a sector erase time-out of 50 μ s occurs. During the time-out period, additional sector addresses and sector erase commands can be written. Loading the sector erase buffer can be done in any sequence, and the number of sectors can be from one sector to all sectors. The time between these additional cycles must be less than 50 μ s, otherwise erasure may begin. Any sector erase address and command following the exceeded time-out can or cannot be accepted. It is recommended that processor interrupts be disabled during this time to ensure all commands are accepted. The interrupts can be re-enabled after the last Sector Erase command is written. **Any command other than Sector Erase or Erase Suspend during the time-out period resets the device to the read mode.** *Note that the Secured Silicon Sector, autoselect, and CFI functions are unavailable when an erase operation is in progress.* The system must rewrite the command sequence and any additional addresses and commands.

The system can monitor DQ3 to determine if the sector erase timer has timed out (See the section on DQ3: Sector Erase Timer.). The time-out begins from the rising edge of the final WE# pulse in the command sequence.

When the Embedded Erase algorithm is complete, the device returns to reading array data and addresses are no longer latched. The system can determine the status of the erase operation by reading DQ7, DQ6, or DQ2 in the erasing sector. See [Write Operation Status](#) for information on these status bits.

Once the sector erase operation starts, only the Erase Suspend command is valid. All other commands are ignored. However, note that a **hardware reset** immediately terminates the erase operation. If that occurs, the sector erase command sequence should be reinitiated once the device returns to reading array data, to ensure data integrity.

[Figure 6](#) illustrates the algorithm for the erase operation. See [Erase and Programming Performance](#) in [AC Characteristics](#) for parameters, and [Figure 18](#) for timing diagrams.

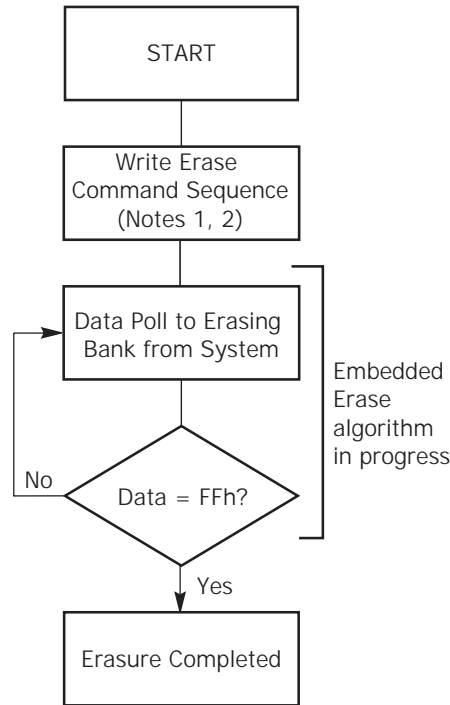

Notes:

1. See [Table 35](#) and [Table 36](#) for program command sequence.
2. See [DQ3: Sector Erase Timer](#) for information on the sector erase timer.

Figure 6. Erase Operation

Erase Suspend/Erasure Resume Commands

The Erase Suspend command, B0h, allows the system to interrupt a sector erase operation and then read data from, or program data to, any sector not selected for erasure. This command is valid only during the sector erase operation, including the 50 μ s time-out period during the sector erase command sequence. The Erase Suspend command is ignored if written during the chip erase operation or Embedded Program algorithm.

When the Erase Suspend command is written during the sector erase operation, the device requires a typical of 5 μ s (maximum of 20 μ s) to suspend the erase operation. However, when the Erase Suspend command is written during the sector erase time-out, the device immediately terminates the time-out period and suspends the erase operation.

After the erase operation is suspended, the device enters the erase-suspend-read mode. The system can read data from or program data to any sector not selected for erasure. (The device “erase suspends” all sectors selected for erasure.) Reading at any address within erase-suspended sectors produces status information on DQ7–DQ0. The system can use DQ7, or DQ6 and DQ2 together, to determine if a sector is actively erasing or is erase-suspended. See [Write Operation Status](#) for information on these status bits.

After an erase-suspended program operation is complete, the device returns to the erase-suspend-read mode. The system can determine the status of the program operation using the DQ7 or DQ6 status bits, just as in the standard word program operation. See [Write Operation Status](#) for more information.

In the erase-suspend-read mode, the system can also issue the autoselect command sequence. See [Autoselect Mode](#) and [Autoselect Command Sequence](#) for details.

To resume the sector erase operation, the system must write the Erase Resume command. Further writes of the Resume command are ignored. Another Erase Suspend command can be written after the chip resumes erasing.

Note: During an erase operation, this flash device performs multiple internal operations which are invisible to the system. When an erase operation is suspended, any of the internal operations that were not fully completed must be restarted. As such, if this flash device is continually issued suspend/resume commands in rapid succession, erase progress are impeded as a function of the number of suspends. The result is a longer cumulative erase time than without suspends. Note that the additional suspends do not affect device reliability or future performance. In most systems rapid erase/suspend activity occurs only briefly. In such cases, erase performance is not significantly impacted.

Command Definitions

Table 35. Command Definitions(x16 Mode, BYTE# = V_{IH})

Command Sequence (Note 1)	Cycles	Bus Cycles (Notes 2–5)												
		First		Second		Third	Fourth		Fifth		Sixth			
		Addr	Data	Addr	Data	Addr	Data	Addr	Data	Addr	Data	Addr	Data	
Read (6)	1	RA	RD											
Reset (7)	1	XXX	FO											
Autoselect (Note 8)	Manufacturer ID	4	555	AA	2AA	55	555	90	X00	0001				
	Device ID (9)	4	555	AA	2AA	55	555	90	X01	227E	X0E	(Note 18)	X0F	(Note 18)
	Secured Silicon Sector Factory Protect (10)	4	555	AA	2AA	55	555	90	X03	(Note 10)				
	Sector Group Protect Verify (12)	4	555	AA	2AA	55	555	90	(SA)X02	00/01				
Enter Secured Silicon Sector Region	3	555	AA	2AA	55	555	88							
Exit Secured Silicon Sector Region	4	555	AA	2AA	55	555	90	XXX	00					
Program	4	555	AA	2AA	55	555	A0	PA	PD					
Write to Buffer (11)	3	555	AA	2AA	55	SA	25	SA	WC	PA	PD	WBL	PD	
Program Buffer to Flash	1	SA	29											
Write to Buffer Abort Reset (13)	3	555	AA	2AA	55	555	FO							
Unlock Bypass	3	555	AA	2AA	55	555	20							
Unlock Bypass Program (14)	2	XXX	A0	PA	PD									
Unlock Bypass Reset (15)	2	XXX	90	XXX	00									
Chip Erase	6	555	AA	2AA	55	555	80	555	AA	2AA	55	555	10	
Sector Erase	6	555	AA	2AA	55	555	80	555	AA	2AA	55	SA	30	
Program/Erase Suspend (16)	1	XXX	B0											
Program/Erase Resume (16)	1	XXX	30											
CFI Query (18)	1	55	98											

Legend:

X = Don't care
 RA = Read Address of memory location to be read.
 RD = Read Data read from location RA during read operation.
 PA = Program Address. Addresses latch on falling edge of WE# or CE# pulse, whichever happens later.

PD = Program Data for location PA. Data latches on rising edge of WE# or CE# pulse, whichever happens first.
 SA = Sector Address of sector to be verified (in autoselect mode) or erased. Address bits A21–A15 uniquely select any sector.
 WBL = Write Buffer Location. Address must be within same write buffer page as PA.
 WC = Word Count. Number of write buffer locations to load minus 1.

Notes:

- See Table 1 for description of bus operations.
- All values are in hexadecimal.
- Shaded cells indicate read cycles. All others are write cycles.
- During unlock and command cycles, when lower address bits are 555 or 2AA as shown in table, address bits above A11 and data bits above DQ7 are don't care.
- No unlock or command cycles required when device is in read mode.
- Reset command is required to return to read mode (or to erase-suspend-read mode if previously in Erase Suspend) when device is in autoselect mode, or if DQ5 goes high while device is providing status information.
- Fourth cycle of the autoselect command sequence is a read cycle. Data bits DQ15–DQ8 are don't care. Except for RD, PD and WC. See Autoselect Command Sequence for more information.
- Device ID must be read in three cycles.
- If WP# protects highest address sector, data is 98h for factory locked and 18h for not factory locked. If WP# protects lowest address sector, data is 88h for factory locked and 08h for not factor locked.
- Data is 00h for an unprotected sector group and 01h for a protected sector group.
- Total number of cycles in command sequence is determined by number of words written to write buffer. Maximum number of cycles in command sequence is 21, including "Program Buffer to Flash" command.
- Command sequence resets device for next command after aborted write-to-buffer operation.
- Unlock Bypass command is required prior to Unlock Bypass Program command.
- Unlock Bypass Reset command is required to return to read mode when device is in unlock bypass mode.
- System may read and program in non-erasing sectors, or enter autoselect mode, when in Erase Suspend mode. Erase Suspend command is valid only during a sector erase operation.
- Erase Resume command is valid only during Erase Suspend mode.
- Command is valid when device is ready to read array data or when device is in autoselect mode.
- Refer to Table 18, AutoSelect Codes for individual Device IDs per device density and model number.

Table 36. Command Definitions (x8 Mode, BYTE# = V_{IL})

Command Sequence (Note 1)	Cycles	Bus Cycles (Notes 2–5)											
		First		Second		Third	Fourth			Fifth		Sixth	
		Addr	Data	Addr	Data	Addr	Data	Addr	Data	Addr	Data	Addr	Data
Read (6)	1	RA	RD										
Reset (7)	1	XXX	FO										
Autoselect (Note 8)	4	AAA	AA	555	55	AAA	90	X00	01				
	4	AAA	AA	555	55	AAA	90	X02	7E	X1C	(Note 17)	X1E	(Note 17)
	4	AAA	AA	555	55	AAA	90	X06	(Note 10)				
	4	AAA	AA	555	55	AAA	90	(SA)X04	00/01				
Enter Secured Silicon Sector Region	3	AAA	AA	555	55	AAA	88						
Exit Secured Silicon Sector Region	4	AAA	AA	555	55	AAA	90	XXX	00				
Write to Buffer (11)	3	AAA	AA	555	55	SA	25	SA	BC	PA	PD	WBL	PD
Program Buffer to Flash	1	SA	29										
Write to Buffer Abort Reset (13)	3	AAA	AA	555	55	AAA	FO						
Chip Erase	6	AAA	AA	555	55	AAA	80	AAA	AA	555	55	AAA	10
Sector Erase	6	AAA	AA	555	55	AAA	80	AAA	AA	555	55	SA	30
Program/Erase Suspend (14)	1	XXX	B0										
Program/Erase Resume (15)	1	XXX	30										
CFI Query (16)	1	AA	98										

Legend:

X = Don't care

RA = Read Address of memory location to be read.

RD = Read Data read from location RA during read operation.

PA = Program Address. Addresses latch on falling edge of WE# or CE# pulse, whichever happens later.

PD = Program Data for location PA. Data latches on rising edge of WE# or CE# pulse, whichever happens first.

SA = Sector Address of sector to be verified (in autoselect mode) or erased. Address bits A21–A15 uniquely select any sector.

WBL = Write Buffer Location. Address must be within same write buffer page as PA.

BC = Byte Count. Number of write buffer locations to load minus 1.

Notes:

- See Table 1 for description of bus operations.
- All values are in hexadecimal.
- Shaded cells indicate read cycles. All others are write cycles.
- During unlock and command cycles, when lower address bits are 555 or AAA as shown in table, address bits above A11 are don't care.
- Unless otherwise noted, address bits A21–A11 are don't cares.
- No unlock or command cycles required when device is in read mode.
- Reset command is required to return to read mode (or to erase-suspend-read mode if previously in Erase Suspend) when device is in autoselect mode, or if DQ5 goes high while device is providing status information.
- Fourth cycle of autoselect command sequence is a read cycle. Data bits DQ15–DQ8 are don't care. See [Autoselect Command Sequence](#) section or more information.
- Device ID must be read in three cycles.
- If WP# protects highest address sector, data is 98h for factory locked and 18h for not factory locked. If WP# protects lowest address sector, data is 88h for factory locked and 08h for not factory locked.
- Data is 00h for an unprotected sector group and 01h for a protected sector group.
- Total number of cycles in command sequence is determined by number of bytes written to write buffer. Maximum number of cycles in command sequence is 37, including "Program Buffer to Flash" command.
- Command sequence resets device for next command after aborted write-to-buffer operation.
- System may read and program in non-erasing sectors, or enter autoselect mode, when in Erase Suspend mode. Erase Suspend command is valid only during a sector erase operation.
- Erase Resume command is valid only during Erase Suspend mode.
- Command is valid when device is ready to read array data or when device is in autoselect mode.
- Refer to Table 18, AutoSelect Codes for individual Device IDs per device density and model number.

Write Operation Status

The device provides several bits to determine the status of a program or erase operation: DQ2, DQ3, DQ5, DQ6, and DQ7. [Table 37](#) and the following subsections describe the function of these bits. DQ7 and DQ6 each offer a method for determining whether a program or erase operation is complete or in progress. The device also provides a hardware-based output signal, RY/BY#, to determine whether an Embedded Program or Erase operation is in progress or is completed.

DQ7: Data# Polling

The Data# Polling bit, DQ7, indicates to the host system whether an Embedded Program or Erase algorithm is in progress or completed, or whether the device is in Erase Suspend. Data# Polling is valid after the rising edge of the final WE# pulse in the command sequence.

During the Embedded Program algorithm, the device outputs on DQ7 the complement of the datum programmed to DQ7. This DQ7 status also applies to programming during Erase Suspend. When the Embedded Program algorithm is complete, the device outputs the datum programmed to DQ7. The system must provide the program address to read valid status information on DQ7. If a program address falls within a protected sector, Data# Polling on DQ7 is active for approximately 1 μ s, then the device returns to the read mode.

During the Embedded Erase algorithm, Data# Polling produces a “0” on DQ7. When the Embedded Erase algorithm is complete, or if the device enters the Erase Suspend mode, Data# Polling produces a “1” on DQ7. The system must provide an address within any of the sectors selected for erasure to read valid status information on DQ7.

After an erase command sequence is written, if all sectors selected for erasing are protected, Data# Polling on DQ7 is active for approximately 100 μ s, then the device returns to the read mode. If not all selected sectors are protected, the Embedded Erase algorithm erases the unprotected sectors, and ignores the selected sectors that are protected. However, if the system reads DQ7 at an address within a protected sector, the status may not be valid.

Just prior to the completion of an Embedded Program or Erase operation, DQ7 can change asynchronously with DQ0–DQ6 while Output Enable (OE#) is asserted low. That is, the device can change from providing status information to valid data on DQ7. Depending on when the system samples the DQ7 output, it can read the status or valid data. Even if the device has completed the program or erase operation and DQ7 has valid data, the data outputs on DQ0–DQ6 may be still invalid. Valid data on DQ0–DQ7 appears on successive read cycles.

[Table 37](#) shows the outputs for Data# Polling on DQ7. [Figure 7](#) shows the Data# Polling algorithm. [Figure 17](#) shows the Data# Polling timing diagram.

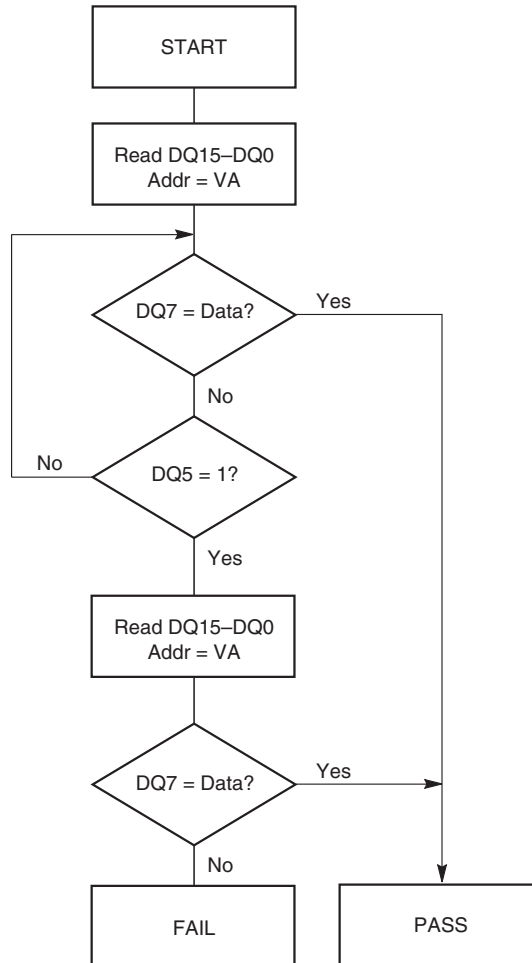
**Notes:**

1. VA = Valid address for programming. During a sector erase operation, a valid address is any sector address within the sector being erased. During chip erase, a valid address is any non-protected sector address.
2. DQ7 should be rechecked even if DQ5 = "1" because DQ7 can change simultaneously with DQ5.

Figure 7. Data# Polling Algorithm**RY/BY#: Ready/Busy#**

The RY/BY# is a dedicated, open-drain output pin which indicates whether an Embedded Algorithm is in progress or complete. The RY/BY# status is valid after the rising edge of the final WE# pulse in the command sequence. Since RY/BY# is an open-drain output, several RY/BY# pins can be tied together in parallel with a pull-up resistor to V_{CC}.

If the output is low (Busy), the device is actively erasing or programming. (This includes programming in the Erase Suspend mode.) If the output is high (Ready), the device is in the read mode, the standby mode, or in the erase-suspend-read mode. [Table 37](#) shows the outputs for RY/BY#.

DQ6: Toggle Bit I

Toggle Bit I on DQ6 indicates whether an Embedded Program or Erase algorithm is in progress or complete, or whether the device entered the Erase Suspend mode. Toggle Bit I may be read at any address, and is valid after the rising edge of the final WE# pulse in the command sequence (prior to the program or erase operation), and during the sector erase time-out.

During an Embedded Program or Erase algorithm operation, successive read cycles to any address cause DQ6 to toggle. The system may use either OE# or CE# to control the read cycles. When the operation is complete, DQ6 stops toggling.

After an erase command sequence is written, if all sectors selected for erasing are protected, DQ6 toggles for approximately 100 μ s, then returns to reading array data. If not all selected sectors are protected, the Embedded Erase algorithm erases the unprotected sectors, and ignores the selected sectors that are protected.

The system can use DQ6 and DQ2 together to determine whether a sector is actively erasing or is erase-suspended. When the device is actively erasing (that is, the Embedded Erase algorithm is in progress), DQ6 toggles. When the device enters the Erase Suspend mode, DQ6 stops toggling. However, the system must also use DQ2 to determine which sectors are erasing or erase-suspended. Alternatively, the system can use DQ7 (see the subsection on DQ7: Data# Polling).

If a program address falls within a protected sector, DQ6 toggles for approximately 1 μ s after the program command sequence is written, then returns to reading array data.

DQ6 also toggles during the erase-suspend-program mode, and stops toggling once the Embedded Program algorithm is complete.

[Table 37](#) shows the outputs for Toggle Bit I on DQ6. [Figure 8](#) shows the toggle bit algorithm. [Figure 20](#) shows the toggle bit timing diagrams. [Figure 21](#) shows the differences between DQ2 and DQ6 in graphical form. Also, see [DQ2: Toggle Bit II](#).

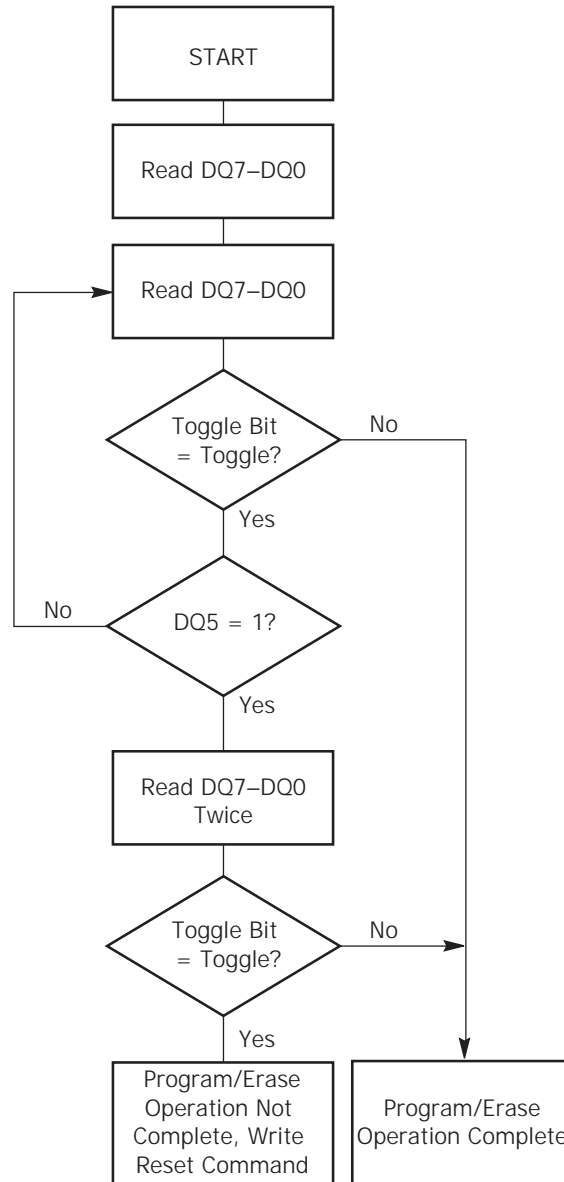

Note: The system should recheck the toggle bit even if DQ5 = "1" because the toggle bit may stop toggling as DQ5 changes to "1." See the subsections on DQ6 and DQ2 for more information.

Figure 8. Toggle Bit Algorithm

DQ2: Toggle Bit II

The "Toggle Bit II" on DQ2, when used with DQ6, indicates whether a particular sector is actively erasing (that is, the Embedded Erase algorithm is in progress), or whether that sector is erase-suspended. Toggle Bit II is valid after the rising edge of the final WE# pulse in the command sequence.

DQ2 toggles when the system reads at addresses within those sectors that are selected for erasure. (The system may use either OE# or CE# to control the read cycles.) But DQ2 cannot distinguish whether the sector is actively erasing or is erase-suspended. DQ6, by comparison, indicates whether the device is actively erasing, or is in Erase Suspend, but cannot distinguish which sectors are selected for erasure. Thus, both status bits are required for sector and mode information. Refer to [Table 37](#) to compare outputs for DQ2 and DQ6.

Figure 8 shows the toggle bit algorithm in flowchart form, and the section “DQ2: Toggle Bit II” explains the algorithm, also see [RY/BY#: Ready/Busy#](#). Figure 20 shows the toggle bit timing diagram. Figure 21 shows the differences between DQ2 and DQ6 in graphical form.

Whenever the system initially begins reading toggle bit status, it must read DQ7–DQ0 at least twice in a row to determine whether a toggle bit is toggling. Typically, the system would note and store the value of the toggle bit after the first read. After the second read, the system would compare the new value of the toggle bit with the first. If the toggle bit is not toggling, the device has completed the program or erase operation. The system can read array data on DQ7–DQ0 on the following read cycle.

However, if after the initial two read cycles, the system determines that the toggle bit is still toggling, the system also should note whether the value of DQ5 is high (see the section on DQ5). If it is, the system should then determine again whether the toggle bit is toggling, since the toggle bit may have stopped toggling just as DQ5 went high. If the toggle bit is no longer toggling, the device has successfully completed the program or erase operation. If it is still toggling, the device did not completed the operation successfully, and the system must write the reset command to return to reading array data.

The remaining scenario is that the system initially determines that the toggle bit is toggling and DQ5 did not go high. The system may continue to monitor the toggle bit and DQ5 through successive read cycles, determining the status as described in the previous paragraph. Alternatively, it may choose to perform other system tasks. In this case, the system must start at the beginning of the algorithm when it returns to determine the status of the operation (top of [Figure 6](#)).

DQ5: Exceeded Timing Limits

DQ5 indicates whether the program, erase, or write-to-buffer time exceeded a specified internal pulse count limit. Under these conditions DQ5 produces a “1,” indicating that the program or erase cycle was not successfully completed.

The device may output a “1” on DQ5 if the system tries to program a “1” to a location that was previously programmed to “0.” **Only an erase operation can change a “0” back to a “1.”** Under this condition, the device halts the operation, and when the timing limit is exceeded, DQ5 produces a “1.”

In all these cases, the system must write the reset command to return the device to the reading the array (or to erase-suspend-read if the device was previously in the erase-suspend-program mode).

DQ3: Sector Erase Timer

After writing a sector erase command sequence, the system may read DQ3 to determine whether or not erasure started. (The sector erase timer does not apply to the chip erase command.) If additional sectors are selected for erasure, the entire time-out also applies after each additional sector erase command. When the time-out period is complete, DQ3 switches from a “0” to a “1.” If the time between additional sector erase commands from the system can be assumed to be less than 50 μ s, the system need not monitor DQ3(see [Sector Erase Command Sequence](#)).

After the sector erase command is written, the system should read the status of DQ7 (Data# Polling) or DQ6 (Toggle Bit I) to ensure that the device accepted the command sequence, and then reads DQ3. If DQ3 is “1,” the Embedded Erase algorithm started; all further commands (except Erase Suspend) are ignored until the erase operation is complete. If DQ3 is “0,” the device accepts additional sector erase commands. To ensure the command was accepted, the system software should check the status of DQ3 prior to and following each subsequent sector erase command. If DQ3 is high on the second status check, the last command might not have been accepted.

[Table 37](#) shows the status of DQ3 relative to the other status bits.

DQ1: Write-to-Buffer Abort

DQ1 indicates whether a Write-to-Buffer operation was aborted. Under these conditions DQ1 produces a "1". The system must issue the Write-to-Buffer-Abort-Reset command sequence to return the device to reading array data. See [Write Buffer](#) for more details.

Table 37. Write Operation Status

Status		DQ7 (Note 2)	DQ6	DQ5 (Note 1)	DQ3	DQ2 (Note 2)	DQ1	RY/BY#		
Standard Mode	Embedded Program Algorithm	DQ7#	Toggle	0	N/A	No toggle	0	0		
	Embedded Erase Algorithm	0	Toggle	0	1	Toggle	N/A	0		
Program Suspend Mode	Program-Suspend Read	Program-Suspended Sector						Invalid (not allowed)		1
	Non-Program Suspend Read	Non-Program Suspend Sector						Data		1
Erase Suspend Mode	Erase-Suspend Read	Erase-Suspended Sector		1	No toggle	0	N/A	Toggle	N/A	1
	Non-Erase Suspend Read	Non-Erase Suspend Sector		Data						1
Write-to-Buffer	Busy (Note 3)	DQ7#	Toggle	0	N/A	N/A	N/A	0	0	
	Abort (Note 4)	DQ7#	Toggle	0	N/A	N/A	1	0		

Notes:

1. DQ5 switches to '1' when an Embedded Program, Embedded Erase, or Write-to-Buffer operation exceeded the maximum timing limits. Refer to the section on DQ5 for more information.
2. DQ7 and DQ2 require a valid address when reading status information. Refer to the appropriate subsection for further details.
3. The Data# Polling algorithm should be used to monitor the last loaded write-buffer address location.
4. DQ1 switches to '1' when the device aborts the write-to-buffer operation

Absolute Maximum Ratings

Storage Temperature, Plastic Packages	-65°C to +150°C
Ambient Temperature with Power Applied	-65°C to +125°C
Voltage with Respect to Ground:	
V _{CC} (Note 1)	-0.5 V to +4.0 V
. A9, OE#, ACC and RESET# (Note 2)	-0.5 V to +12.5 V
All other pins (Note 1)	-0.5 V to V _{CC} +0.5 V
Output Short Circuit Current (Note 3)	200 mA

Notes:

1. Minimum DC voltage on input or I/Os is -0.5 V. During voltage transitions, inputs or I/Os may overshoot V_{SS} to -2.0 V for periods of up to 20 ns. See Figure 9, Maximum Negative Overshoot Waveform. Maximum DC voltage on input or I/Os is V_{CC} + 0.5 V. During voltage transitions, input or I/O pins may overshoot to V_{CC} + 2.0 V for periods up to 20 ns. See Figure 10.
2. Minimum DC input voltage on pins A9, OE#, ACC, and RESET# is -0.5 V. During voltage transitions, A9, OE#, ACC, and RESET# may overshoot V_{SS} to -2.0 V for periods of up to 20 ns. See Figure 9. Maximum DC input voltage on pin A9, OE#, ACC, and RESET# is +12.5 V which may overshoot to +14.0V for periods up to 20 ns.
3. No more than one output may be shorted to ground at a time. Duration of the short circuit should not be greater than one second.
4. Stresses above those listed under "Absolute Maximum Ratings" may cause permanent damage to the device. This is a stress rating only; functional operation of the device at these or any other conditions above those indicated in the operational sections of this data sheet is not implied. Exposure of the device to absolute maximum rating conditions for extended periods may affect device reliability.

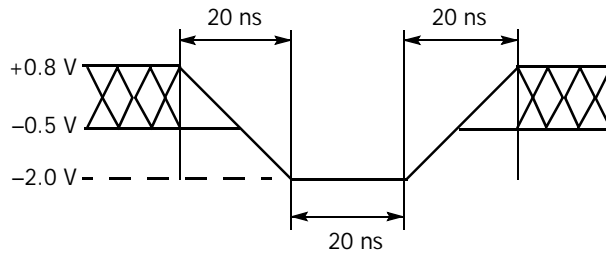

Figure 9. Maximum Negative Overshoot Waveform

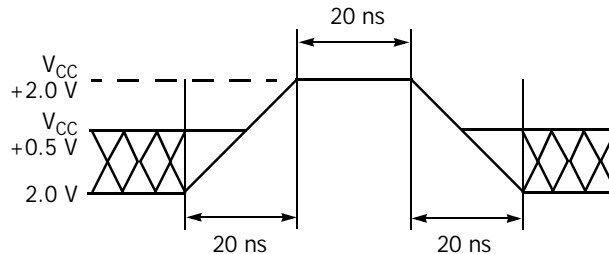

Figure 10. Maximum Positive Overshoot Waveform

Industrial (I) Devices

Ambient Temperature (T _A)	-40°C to +85°C
---	----------------

Supply Voltages

V _{CC} for full voltage range	+2.7 V to +3.6 V
V _{CC} for regulated voltage range	+3.0 V to +3.6 V
V _{IO}	V _{CC}

Note: Operating ranges define those limits between which the functionality of the device is guaranteed.

DC Characteristics

CMOS Compatible

Parameter Symbol	Parameter Description (Notes)	Test Conditions	Min	Typ	Max	Unit
I_{LI}	Input Load Current (1)	$V_{IN} = V_{SS}$ to V_{CC} , $V_{CC} = V_{CC\ max}$			± 1.0	μA
I_{LIT}	A9, ACC Input Load Current	$V_{CC} = V_{CC\ max}$; A9 = 12.5 V			35	μA
I_{LR}	Reset Leakage Current	$V_{CC} = V_{CC\ max}$; RESET# = 12.5 V			35	μA
I_{LO}	Output Leakage Current	$V_{OUT} = V_{SS}$ to V_{CC} , $V_{CC} = V_{CC\ max}$			± 1.0	μA
I_{CC1}	V_{CC} Initial Read Current (2, 3)	CE# = V_{IL} , OE# = V_{IH} ,	1 MHz	5	20	mA
			5 MHz (4)	18	25	
			5 MHz (5)	25	35	
			10 MHz (4)	35	50	
			10 MHz (5)	40	60	
I_{CC2}	V_{CC} Intra-Page Read Current (2, 3)	CE# = V_{IL} , OE# = V_{IH}	10 MHz	5	20	mA
		40 MHz	10	40		
I_{CC3}	V_{CC} Active Write Current (3, 4)	CE# = V_{IL} , OE# = V_{IH}		50	60	mA
I_{CC4}	V_{CC} Standby Current (3)	CE#, RESET# = $V_{CC} \pm 0.3$ V, WP# = V_{IH}		1	5	μA
I_{CC5}	V_{CC} Reset Current (3)	RESET# = $V_{SS} \pm 0.3$ V, WP# = V_{IH}		1	5	μA
I_{CC6}	Automatic Sleep Mode (3, 7)	$V_{IH} = V_{CC} \pm 0.3$ V; $-0.1 < V_{IL} \leq 0.3$ V, WP# = V_{IH}		1	5	μA
V_{IL}	Input Low Voltage (1, 8)		-0.5		0.8	V
V_{IH}	Input High Voltage (1, 8)		$0.7 V_{CC}$		$V_{CC} + 0.5$	V
V_{HH}	Voltage for ACC Program Acceleration	$V_{CC} = 2.7 - 3.6$ V	11.5	12.0	12.5	V
V_{ID}	Voltage for Autoselect and Temporary Sector Unprotect	$V_{CC} = 2.7 - 3.6$ V	11.5	12.0	12.5	V
V_{OL}	Output Low Voltage (8)	$I_{OL} = 4.0$ mA, $V_{CC} = V_{CC\ min}$			0.45	V
V_{OH1}	Output High Voltage	$I_{OH} = -2.0$ mA, $V_{CC} = V_{CC\ min}$	$0.85 V_{CC}$			V
V_{OH2}		$I_{OH} = -100$ μA , $V_{CC} = V_{CC\ min}$	$V_{CC} - 0.4$			V
V_{LKO}	Low V_{CC} Lock-Out Voltage (9)			2.3	2.5	V

Notes:

1. On the WP#/ACC pin only, the maximum input load current when WP# = V_{IL} is ± 5.0 μA .
2. The I_{CC} current listed is typically less than 3.5 mA/MHz, with OE# at V_{IH} .
3. Maximum I_{CC} specifications are tested with $V_{CC} = V_{CC\ max}$.
4. S29GL032M, S29GL064M
5. S29GL128M, S29GL256M
6. I_{CC} active while Embedded Erase or Embedded Program is in progress.
7. Automatic sleep mode enables the low power mode when addresses remain stable for $t_{ACC} + 30$ ns.
8. V_{CC} voltage requirements.
9. Not 100% tested.

Test Conditions

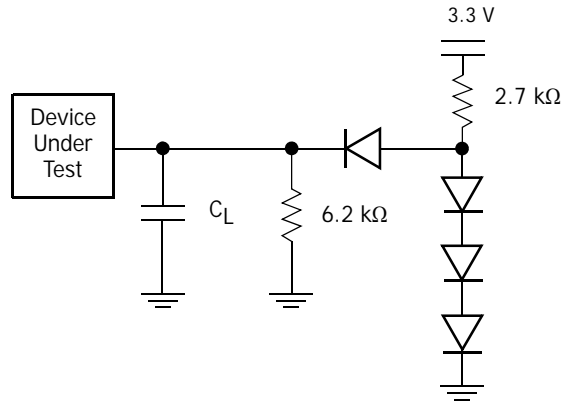

Note: Diodes are IN3064 or equivalent

Figure II. Test Setup

Table 38. Test Specifications

Test Condition	All Speeds	Unit
Output Load	1 TTL gate	
Output Load Capacitance, C_L (including jig capacitance)	30	pF
Input Rise and Fall Times	5	ns
Input Pulse Levels	0.0 or V_{CC}	V
Input timing measurement reference levels (See Note)	$0.5 V_{CC}$	V
Output timing measurement reference levels	$0.5 V_{CC}$	V

Key to Switching Waveforms

WAVEFORM	INPUTS	OUTPUTS
	Steady	
	Changing from H to L	
	Changing from L to H	
	Don't Care, Any Change Permitted	Changing, State Unknown
	Does Not Apply	Center Line is High Impedance State (High Z)

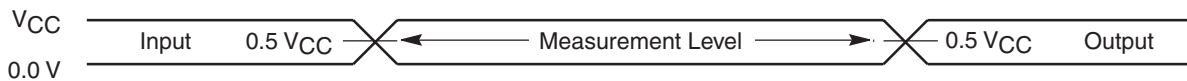

Figure I2. Input Waveforms and Measurement Levels

AC Characteristics

Read-Only Operations-S29GL256M Only

Parameter		Description	Test Setup	Speed Options		Unit	
JEDEC	Std.			10	11		
t _{AVAV}	t _{RC}	Read Cycle Time (Note 1)		Min	100	100	ns
t _{AVQV}	t _{ACC}	Address to Output Delay	CE#, OE# = V _{IL}	Max	100	100	ns
t _{ELOV}	t _{CE}	Chip Enable to Output Delay	OE# = V _{IL}	Max	100	100	ns
	t _{PACC}	Page Access Time		Max	30	30	ns
t _{GLQV}	t _{OE}	Output Enable to Output Delay		Max	30	30	ns
t _{EHOZ}	t _{DF}	Chip Enable to Output High Z (Note 1)		Max	16		ns
t _{GHOZ}	t _{DF}	Output Enable to Output High Z (Note 1)		Max	16		ns
t _{AXQX}	t _{OH}	Output Hold Time From Addresses, CE# or OE#, Whichever Occurs First		Min	0		ns
	t _{OEH}	Output Enable Hold Time (Note 1)	Read	Min	0		ns
			Toggle and Data# Polling	Min	10		ns

Notes:

1. Not 100% tested.
2. See [Figure 11](#) and [Table 38](#) for test specifications.

Read-Only Operations-S29GL128M only

Parameter		Description	Test Setup	Speed Options		Unit	
JEDEC	Std.			90	10		
t _{AVAV}	t _{RC}	Read Cycle Time (Note 1)		Min	90	100	ns
t _{AVQV}	t _{ACC}	Address to Output Delay	CE#, OE# = V _{IL}	Max	90	100	ns
t _{ELOV}	t _{CE}	Chip Enable to Output Delay	OE# = V _{IL}	Max	90	100	ns
	t _{PACC}	Page Access Time		Max	25	30	ns
t _{GLQV}	t _{OE}	Output Enable to Output Delay		Max	25	30	ns
t _{EHOZ}	t _{DF}	Chip Enable to Output High Z (Note 1)		Max	16		ns
t _{GHOZ}	t _{DF}	Output Enable to Output High Z (Note 1)		Max	16		ns
t _{AXQX}	t _{OH}	Output Hold Time From Addresses, CE# or OE#, Whichever Occurs First		Min	0		ns
	t _{OEH}	Output Enable Hold Time (Note 1)	Read	Min	0		ns
			Toggle and Data# Polling	Min	10		ns

Notes:

1. Not 100% tested.
2. See [Figure 11](#) and [Table 38](#) for test specifications.

Read-Only Operations-S29GL064M Only

Parameter		Description	Test Setup	Speed Options			Unit	
JEDEC	Std.			90	10	11		
t _{AVAV}	t _{RC}	Read Cycle Time (Note 1)		Min	90	100	110	ns
t _{AVQV}	t _{ACC}	Address to Output Delay	CE#, OE# = V _{IL}	Max	90	100	110	ns
t _{ELOV}	t _{CE}	Chip Enable to Output Delay	OE# = V _{IL}	Max	90	100	110	ns
	t _{PACC}	Page Access Time		Max	25	30	30	ns
t _{GLQV}	t _{OE}	Output Enable to Output Delay		Max	25	30	30	ns
t _{EHOZ}	t _{DF}	Chip Enable to Output High Z (See Note)		Max	16		ns	
t _{GHOZ}	t _{DF}	Output Enable to Output High Z (See Note)		Max	16		ns	
t _{AXQX}	t _{OH}	Output Hold Time From Addresses, CE# or OE#, Whichever Occurs First		Min	0		ns	
	t _{OEH}	Output Enable Hold Time (See Note)	Read	Min	0		ns	
			Toggle and Data# Polling	Min	10		ns	

Note: Not 100% tested.

AC Characteristics

Read-Only Operations-S29GL032M only

Parameter		Description	Test Setup	Speed Options			Unit	
JEDEC	Std.			90	10	11		
t_{AVAV}	t_{RC}	Read Cycle Time (Note 1)	Min	90	100	110	ns	
t_{AVOQ}	t_{ACC}	Address to Output Delay	CE#, OE# = V_{IL}	Max	90	100	110	ns
t_{ELOV}	t_{CE}	Chip Enable to Output Delay	OE# = V_{IL}	Max	90	100	110	ns
	t_{PACC}	Page Access Time		Max	25	30	30	ns
t_{GLOV}	t_{OE}	Output Enable to Output Delay		Max	25	30	30	ns
t_{EHOZ}	t_{DF}	Chip Enable to Output High Z (Note 1)		Max	16		ns	
t_{GHOZ}	t_{DF}	Output Enable to Output High Z (Note 1)		Max	16		ns	
t_{AXQX}	t_{OH}	Output Hold Time From Addresses, CE# or OE#, Whichever Occurs First		Min	0		ns	
	t_{OEh}	Output Enable Hold Time (Note 1)	Read	Min	0		ns	
	t_{OEh}	Output Enable Hold Time (Note 1)	Toggle and Data# Polling	Min	10		ns	

Notes:

1. Not 100% tested.
2. See Figure 11 and Table 38 for test specifications.

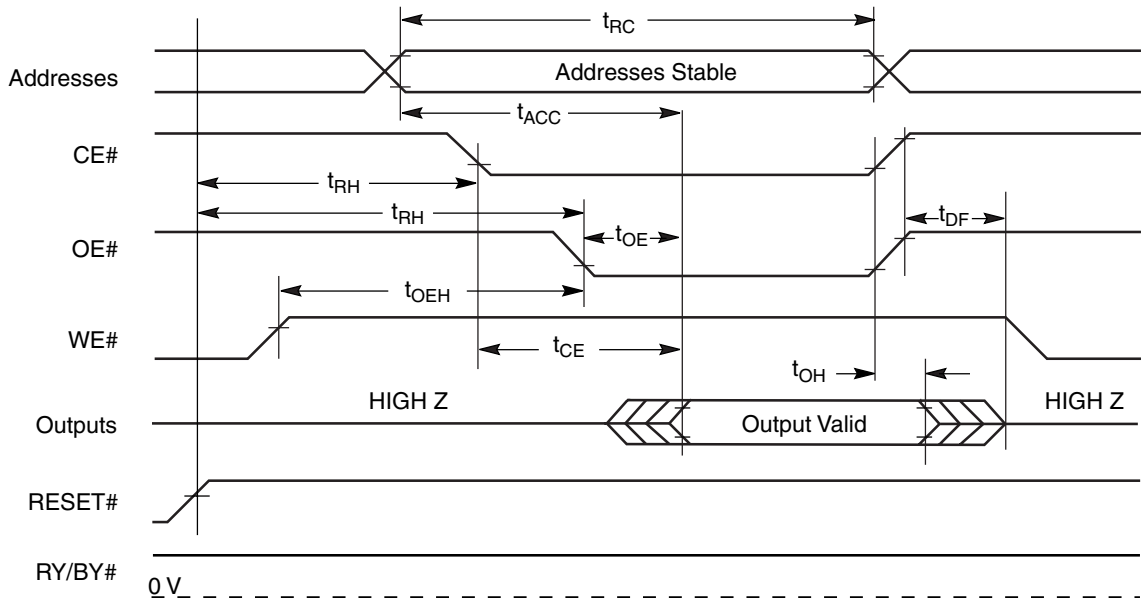
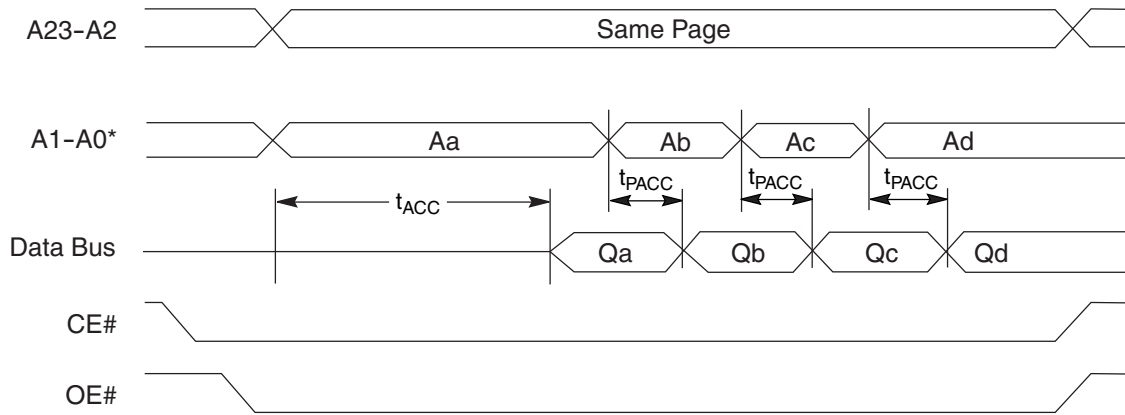

Figure I3. Read Operation Timings

AC Characteristics



Note: Figure shows device in word mode. Addresses are A1–A-1 for byte mode.

Figure I4. Page Read Timings

Hardware Reset (RESET#)

Parameter		Description		All Speed Options	Unit
JEDEC	Std.				
	t_{Ready}	RESET# Pin Low (During Embedded Algorithms) to Read Mode (See Note)	Max	20	μ s
	t_{Ready}	RESET# Pin Low (NOT During Embedded Algorithms) to Read Mode (See Note)	Max	500	ns
	t_{RP}	RESET# Pulse Width	Min	500	ns
	t_{RH}	Reset High Time Before Read (See Note)	Min	50	ns
	t_{RPD}	RESET# Input Low to Standby Mode (See Note)	Min	20	μ s
	t_{RB}	RY/BY# Output High to CE#, OE# pin Low	Min	0	ns

Note: Not 100% tested.

AC Characteristics

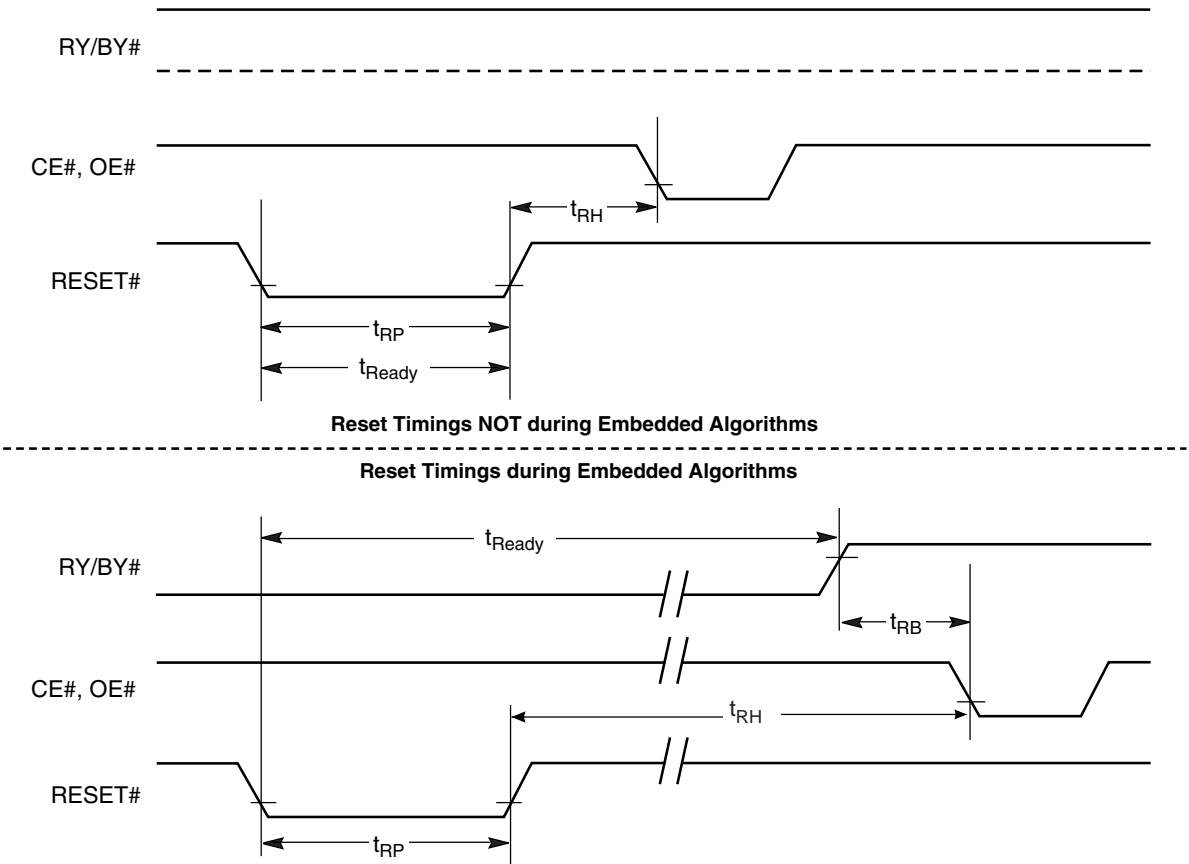

Figure 15. Reset Timings

AC Characteristics

Erase and Program Operations-S29GL256M Only

Parameter		Description		Speed Options		Unit
JEDEC	Std.			10	11	
t_{AVAV}	t_{WC}	Write Cycle Time (Note 1)	Min	100	110	ns
t_{AVWL}	t_{AS}	Address Setup Time	Min	0		ns
	t_{ASO}	Address Setup Time to OE# low during toggle bit polling	Min	15		ns
t_{WLAX}	t_{AH}	Address Hold Time	Min	45		ns
	t_{AHT}	Address Hold Time From CE# or OE# high during toggle bit polling	Min	0		ns
t_{DVWH}	t_{DS}	Data Setup Time	Min	45		ns
t_{WHDX}	t_{DH}	Data Hold Time	Min	0		ns
	t_{CEPH}	CE# High during toggle bit polling	Min	20		ns
	t_{OEPH}	OE# High during toggle bit polling	Min	20		ns
t_{GHWL}	t_{GHWL}	Read Recovery Time Before Write (OE# High to WE# Low)	Min	0		ns
t_{ELWL}	t_{CS}	CE# Setup Time	Min	0		ns
t_{WHEH}	t_{CH}	CE# Hold Time	Min	0		ns
t_{WLWH}	t_{WP}	Write Pulse Width	Min	35		ns
t_{WHDL}	t_{WPH}	Write Pulse Width High	Min	30		ns
t_{WHWH1}	t_{WHWH1}	Write Buffer Program Operation (Notes 2, 3)	Typ	240		μ s
		Single Word Program Operation (Note 2)	Typ	60		
		Accelerated Single Word Program Operation (Note 2)	Typ	54		
t_{WHWH2}	t_{WHWH2}	Sector Erase Operation (Note 2)	Typ	0.5		sec
	t_{VHH}	V_{HH} Rise and Fall Time (Note 1)	Min	250		ns
	t_{VCS}	V_{CC} Setup Time (Note 1)	Min	50		μ s
	t_{BUSY}	WE# High to RY/BY# Low	Min	100	110	ns
	t_{POLL}	Program Valid before Status Polling	Max	4		μ s

Notes:

1. Not 100% tested.
2. See [Erase and Programming Performance](#) for more information.
3. For 1–16 words/1–32 bytes programmed.
4. If a program suspend command is issued within t_{POLL} , the device requires t_{POLL} before reading status data, once programming resumes (that is, the program resume command is written). If the suspend command was issued after t_{POLL} , status data is available immediately after programming resumes. See [Figure 16](#).

AC Characteristics

Erase and Program Operations-S29GLI28M Only

Parameter		Description		Speed Options		Unit
JEDEC	Std.			90	10	
t _{AVAV}	t _{WC}	Write Cycle Time (Note 1)	Min	90	100	ns
t _{AVWL}	t _{AS}	Address Setup Time	Min	0		ns
	t _{ASO}	Address Setup Time to OE# low during toggle bit polling	Min	15		ns
t _{WLAX}	t _{AH}	Address Hold Time	Min	45		ns
	t _{AHT}	Address Hold Time From CE# or OE# high during toggle bit polling	Min	0		ns
t _{DVWH}	t _{DS}	Data Setup Time	Min	45		ns
t _{WHDX}	t _{DH}	Data Hold Time	Min	0		ns
	t _{CEPH}	CE# High during toggle bit polling	Min	20		ns
	t _{OEPH}	OE# High during toggle bit polling	Min	20		ns
t _{GHWL}	t _{GHWL}	Read Recovery Time Before Write (OE# High to WE# Low)	Min	0		ns
t _{ELWL}	t _{CS}	CE# Setup Time	Min	0		ns
t _{WHEH}	t _{CH}	CE# Hold Time	Min	0		ns
t _{WLWH}	t _{WP}	Write Pulse Width	Min	35		ns
t _{WHDL}	t _{WPH}	Write Pulse Width High	Min	30		ns
t _{WHWH1}	t _{WHWH1}	Write Buffer Program Operation (Notes 2, 3)	Typ	240		μs
		Single Word Program Operation (Note 2)	Typ	60		
		Accelerated Single Word Program Operation (Note 2)	Typ	54		
t _{WHWH2}	t _{WHWH2}	Sector Erase Operation (Note 2)	Typ	0.5		sec
	t _{VHH}	V _{HH} Rise and Fall Time (Note 1)	Min	250		ns
	t _{VCS}	V _{CC} Setup Time (Note 1)	Min	50		μs
	t _{BUSY}	WE# High to RY/BY# Low	Min	90	100	ns
	t _{POLL}	Program Valid before Status Polling	Max	4		μs

Notes:

1. Not 100% tested.
2. See [Erase and Programming Performance](#) for more information
3. For 1–16 words/1–32 bytes programmed.
4. If a program suspend command is issued within t_{POLL}, the device requires t_{POLL} before reading status data, once programming resumes (that is, the program resume command has been written). If the suspend command was issued after t_{POLL}, status data is available immediately after programming resumes. See [Figure 16](#).

AC Characteristics

Erase and Program Operations-S29GL064M Only

Parameter		Description	Speed Options			Unit	
JEDEC	Std.		90	10	11		
t_{AVAV}	t_{WC}	Write Cycle Time (Note 1)	Min	90	100	110	ns
t_{AVWL}	t_{AS}	Address Setup Time	Min	0			ns
	t_{ASO}	Address Setup Time to OE# low during toggle bit polling	Min	15			ns
t_{WLAX}	t_{AH}	Address Hold Time	Min	45			ns
	t_{AHT}	Address Hold Time From CE# or OE# high during toggle bit polling	Min	0			ns
t_{DVWH}	t_{DS}	Data Setup Time	Min	35			ns
t_{WHDX}	t_{DH}	Data Hold Time	Min	0			ns
	t_{CEPH}	CE# High during toggle bit polling	Min	20			ns
	t_{OEPH}	OE# High during toggle bit polling	Min	20			ns
t_{GHWL}	t_{GHWL}	Read Recovery Time Before Write (OE# High to WE# Low)	Min	0			ns
t_{ELWL}	t_{CS}	CE# Setup Time	Min	0			ns
t_{WHEH}	t_{CH}	CE# Hold Time	Min	0			ns
t_{WLWH}	t_{WP}	Write Pulse Width	Min	35			ns
t_{WHDL}	t_{WPH}	Write Pulse Width High	Min	30			ns
t_{WHWH1}	t_{WHWH1}	Write Buffer Program Operation (Notes 2, 3)	Typ	240			μ s
		Single Word Program Operation (Note 2)	Typ	60			
		Accelerated Single Word Program Operation (Note 2)	Typ	54			
t_{WHWH2}	t_{WHWH2}	Sector Erase Operation (Note 2)	Typ	0.5			sec
	t_{VHH}	V_{HH} Rise and Fall Time (Note 1)	Min	250			ns
	t_{VCS}	V_{CC} Setup Time (Note 1)	Min	50			μ s
	t_{BUSY}	WE# High to RY/BY# Low	Min	90	100	110	ns
	t_{POLL}	Program Valid before Status Polling	Max	4			μ s

Notes:

1. Not 100% tested.
2. See [Erase and Programming Performance](#) for more information
3. For 1–16 words/1–32 bytes programmed.
4. If a program suspend command is issued within t_{POLL} , the device requires t_{POLL} before reading status data, once programming resumes (that is, the program resume command has been written). If the suspend command was issued after t_{POLL} , status data is available immediately after programming resumes. See [Figure 16](#).

AC Characteristics

Erase and Program Operations-S29GL032M Only

Parameter		Description		Speed Options			Unit
JEDEC	Std.			90	10	11	
t _{AVAV}	t _{WC}	Write Cycle Time (Note 1)	Min	90	100	110	ns
t _{AVWL}	t _{AS}	Address Setup Time	Min	0			ns
	t _{ASO}	Address Setup Time to OE# low during toggle bit polling	Min	15			ns
t _{WLAX}	t _{AH}	Address Hold Time	Min	45			ns
	t _{AHT}	Address Hold Time From CE# or OE# high during toggle bit polling	Min	0			ns
t _{DVWH}	t _{DS}	Data Setup Time	Min	35			ns
t _{WHDX}	t _{DH}	Data Hold Time	Min	0			ns
	t _{CEPH}	CE# High during toggle bit polling	Min	20			ns
	t _{OEPH}	OE# High during toggle bit polling	Min	20			ns
t _{GHWL}	t _{GHWL}	Read Recovery Time Before Write (OE# High to WE# Low)	Min	0			ns
t _{ELWL}	t _{CS}	CE# Setup Time	Min	0			ns
t _{WHEH}	t _{CH}	CE# Hold Time	Min	0			ns
t _{WLWH}	t _{WP}	Write Pulse Width	Min	35			ns
t _{WHDL}	t _{WPH}	Write Pulse Width High	Min	30			ns
t _{WHWH1}	t _{WHWH1}	Write Buffer Program Operation (Notes 2, 3)	Typ	240			μs
		Single Word Program Operation (Note 2)	Typ	60			
		Accelerated Single Word Program Operation (Note 2)	Typ	54			
t _{WHWH2}	t _{WHWH2}	Sector Erase Operation (Note 2)	Typ	0.5			sec
	t _{VHH}	V _{HH} Rise and Fall Time (Note 1)	Min	250			ns
	t _{VCS}	V _{CC} Setup Time (Note 1)	Min	50			μs
	t _{BUSY}	WE# High to RY/BY# Low	Min	90	100	110	ns
	t _{POLL}	Program Valid before Status Polling	Max	4			μs

Notes:

1. Not 100% tested.
2. See [Erase and Programming Performance](#) for more information
3. For 1–16 words/1–32 bytes programmed.
4. Effective write buffer specification is based upon a 16-word/32-byte write buffer operation.
5. If a program suspend command is issued within t_{POLL}, the device requires t_{POLL} before reading status data, once programming resumes (that is, the program resume command has been written). If the suspend command was issued after t_{POLL}, status data is available immediately after programming resumes. See [Figure 16](#).

AC Characteristics

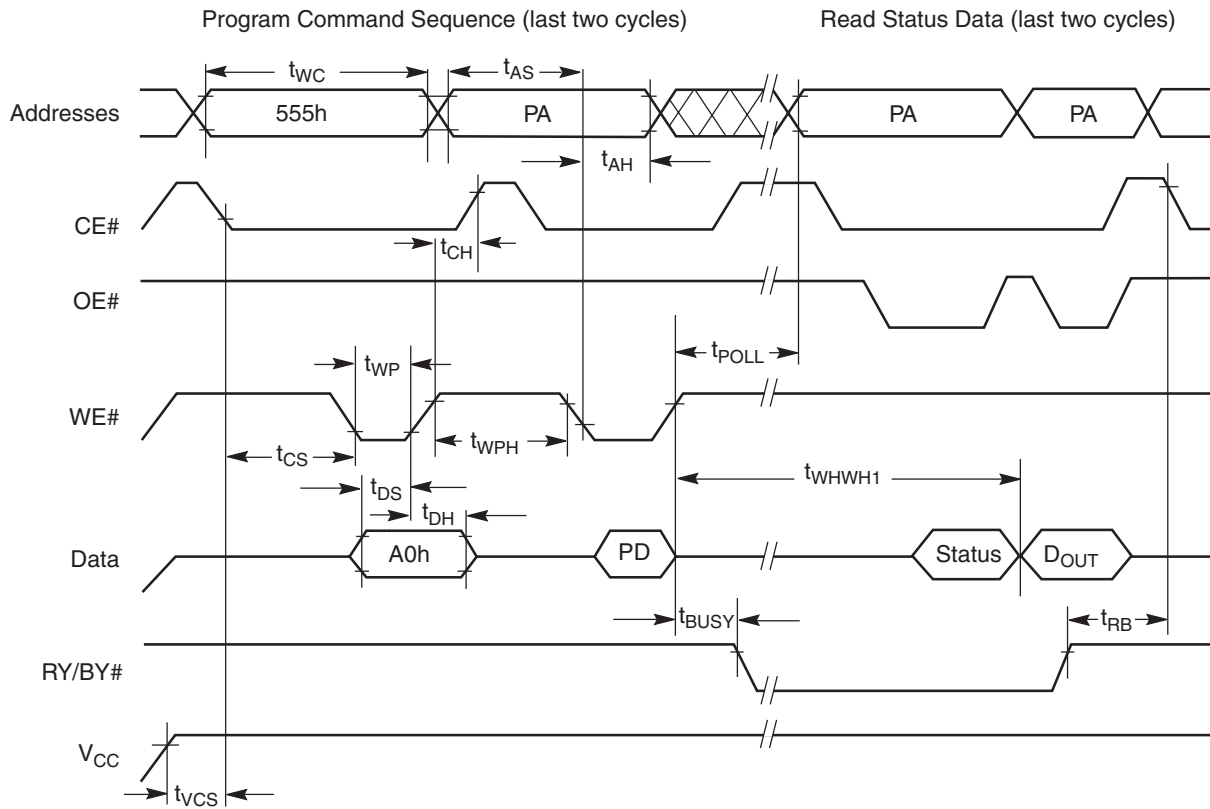

Notes:

1. PA = program address, PD = program data, D_{OUT} is the true data at the program address.
2. Illustration shows device in word mode.

Figure 16. Program Operation Timings

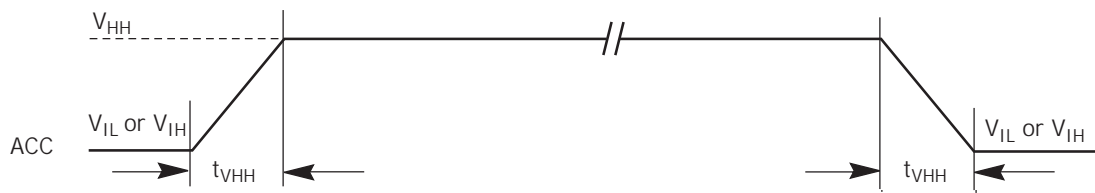
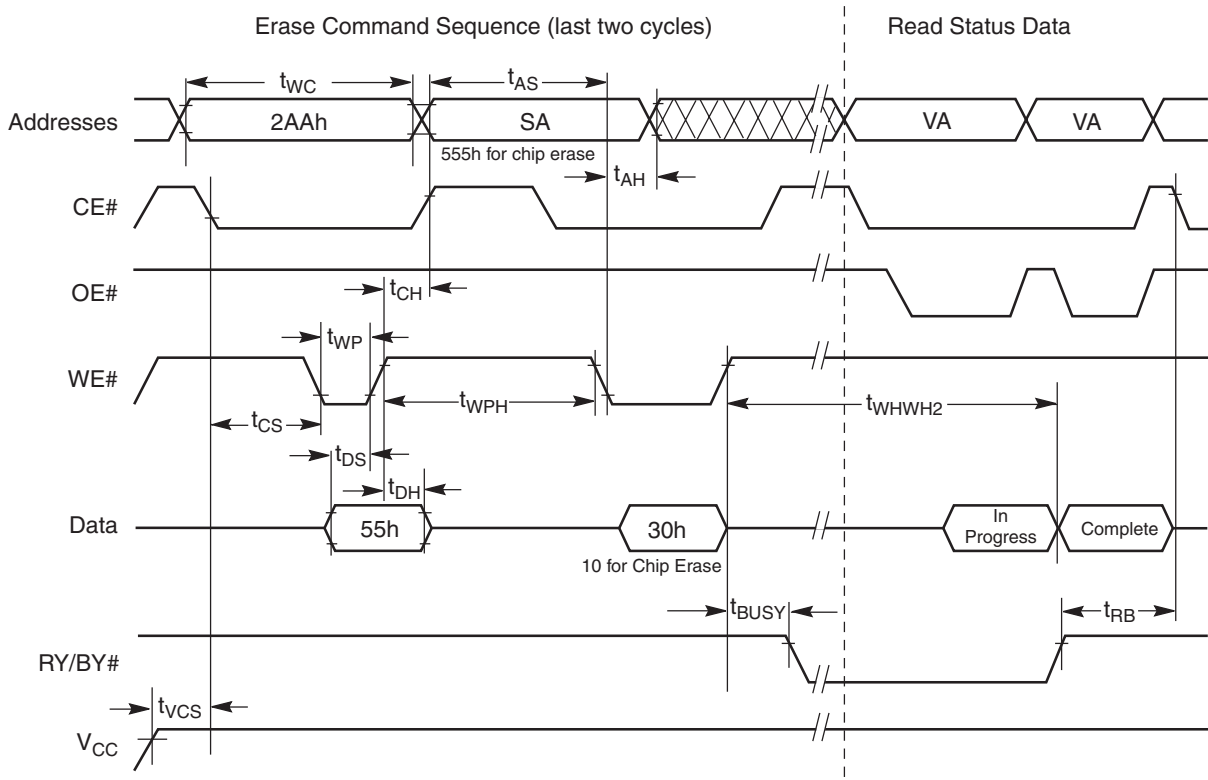

Figure 17. Accelerated Program Timing Diagram

AC Characteristics



Notes:

1. SA = sector address (for Sector Erase), VA = Valid Address for reading status data (see [Write Operation Status](#)).
2. Illustration shows device in word mode.

Figure 18. Chip/Sector Erase Operation Timings

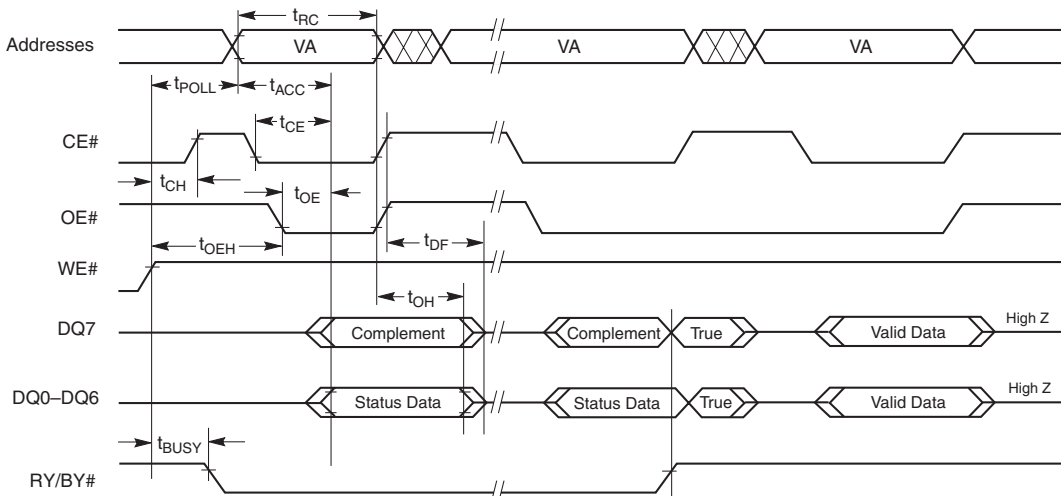

Note: VA = Valid address. Illustration shows first status cycle after command sequence, last status read cycle, and array data read cycle.

Figure 19. Data# Polling Timings (During Embedded Algorithms)

AC Characteristics

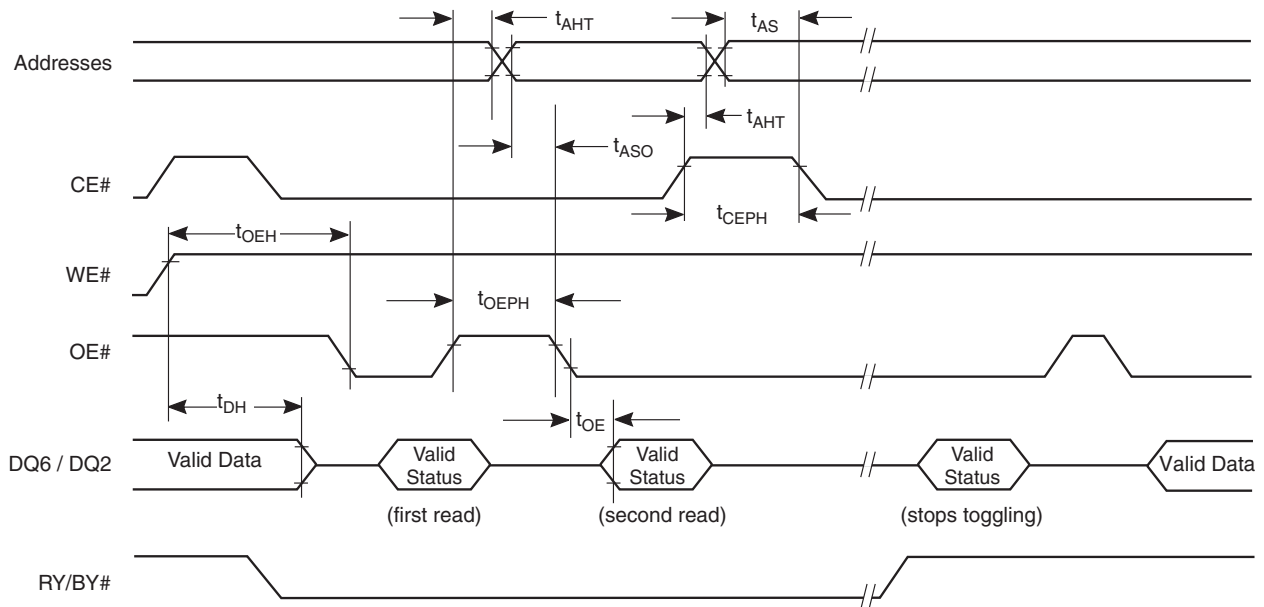

Note: VA = Valid address; not required for DQ6. Illustration shows first two status cycle after command sequence, last status read cycle, and array data read cycle.

Figure 20. Toggle Bit Timings (During Embedded Algorithms)

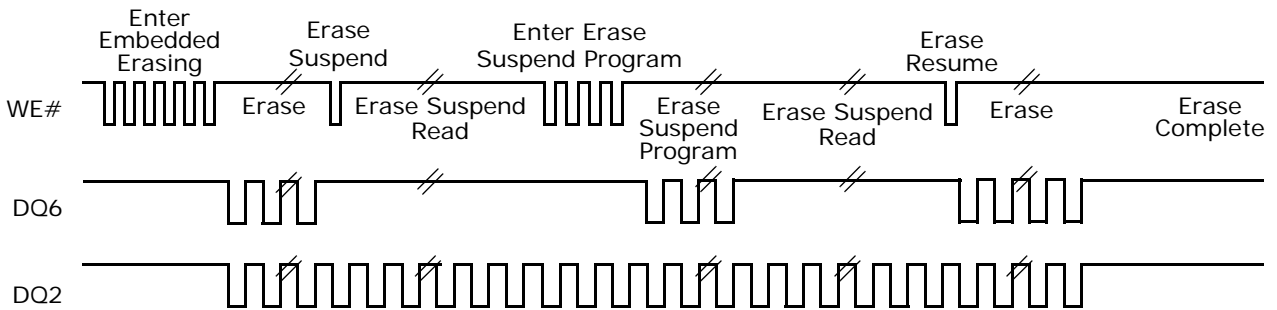

Note: DQ2 toggles only when read at an address within an erase-suspended sector. The system may use OE# or CE# to toggle DQ2 and DQ6.

Figure 21. DQ2 vs. DQ6

Temporary Sector Unprotect

Parameter		Description	All Speed Options	Unit	
JEDEC	Std				
	t_{VIDR}	V_{ID} Rise and Fall Time (See Note)	Min	500	ns
	t_{RSP}	RESET# Setup Time for Temporary Sector Unprotect	Min	4	μ s

Note: Not 100% tested.

AC Characteristics

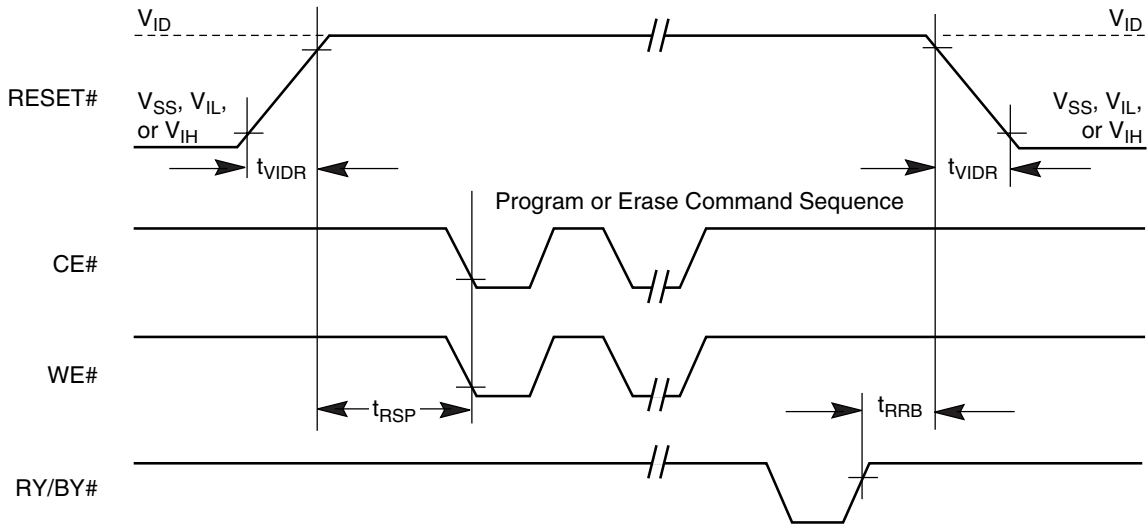
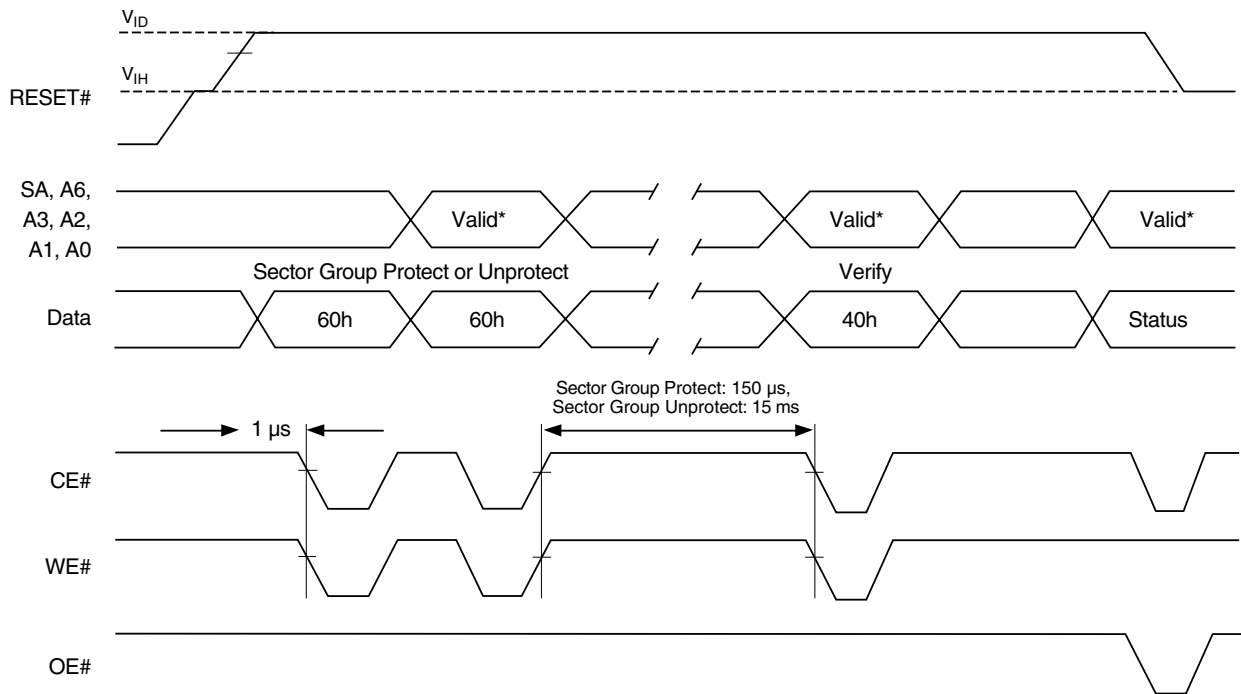

Figure 22. Temporary Sector Group Unprotect Timing Diagram



Note: For sector group protect, A6:A0 = 0xx0010. For sector group unprotect, A6:A0 = 1xx0010.

Figure 23. Sector Group Protect and Unprotect Timing Diagram

Alternate CE# Controlled Erase and Program Operations-S29GL256M

Parameter		Description		Speed Options		Unit
JEDEC	Std.			10	11	
t _{AVAV}	t _{WC}	Write Cycle Time (Note 1)	Min	100	110	ns
t _{AVWL}	t _{AS}	Address Setup Time	Min	0		ns
t _{ELAX}	t _{AH}	Address Hold Time	Min	45		ns
t _{DVEH}	t _{DS}	Data Setup Time	Min	45		ns
t _{EHDX}	t _{DH}	Data Hold Time	Min	0		ns
t _{GHEL}	t _{GHEL}	Read Recovery Time Before Write (OE# High to WE# Low)	Min	0		ns
t _{WLEL}	t _{WS}	WE# Setup Time	Min	0		ns
t _{EHWH}	t _{WH}	WE# Hold Time	Min	0		ns
t _{ELEH}	t _{CP}	CE# Pulse Width	Min	35		ns
t _{EHEL}	t _{CPH}	CE# Pulse Width High	Min	25		ns
t _{WHWH1}	t _{WHWH1}	Write Buffer Program Operation (Notes 2, 3)	Typ	240		μs
		Single Word Program Operation (Note 2)	Typ	60		
		Accelerated Single Word Program Operation (Note 2)	Typ	54		
t _{WHWH2}	t _{WHWH2}	Sector Erase Operation (Note 2)	Typ	0.5		sec
	t _{RH}	RESET# High Time Before Write	Min	50		ns
	t _{POLL}	Program Valid before Status Polling	Max	4		μs

Notes:

1. Not 100% tested.
2. See [Erase and Programming Performance](#) for more information
3. For 1–16 words/1–32 bytes programmed.
4. If a program suspend command is issued within t_{POLL}, the device requires t_{POLL} before reading status data, once programming resume (that is, the program resume command has been written). If the suspend command was issued after t_{POLL}, status data is available immediately after programming resumes. See [Figure 24](#).

Alternate CE# Controlled Erase and Program Operations-S29GL128M

Parameter		Description		Speed Options		Unit
JEDEC	Std.			10	11	
t _{AVAV}	t _{WC}	Write Cycle Time (Note 1)	Min	100	110	ns
t _{AVWL}	t _{AS}	Address Setup Time	Min	0		ns
t _{ELAX}	t _{AH}	Address Hold Time	Min	45		ns
t _{DVEH}	t _{DS}	Data Setup Time	Min	45		ns
t _{EHDX}	t _{DH}	Data Hold Time	Min	0		ns
t _{GHEL}	t _{GHEL}	Read Recovery Time Before Write (OE# High to WE# Low)	Min	0		ns
t _{WLEL}	t _{WS}	WE# Setup Time	Min	0		ns
t _{EHWH}	t _{WH}	WE# Hold Time	Min	0		ns
t _{ELEH}	t _{CP}	CE# Pulse Width	Min	35		ns
t _{EHEL}	t _{CPH}	CE# Pulse Width High	Min	25		ns
t _{WHWH1}	t _{WHWH1}	Write Buffer Program Operation (Notes 2, 3)	Typ	240		μs
		Single Word Program Operation (Note 2)	Typ	60		
		Accelerated Single Word Program Operation (Note 2)	Typ	54		
t _{WHWH2}	t _{WHWH2}	Sector Erase Operation (Note 2)	Typ	0.5		sec
	t _{RH}	RESET# High Time Before Write	Min	50		ns
	t _{POLL}	Program Valid before Status Polling (Note 4)	Max	4		μs

Notes:

1. Not 100% tested.
2. See [Erase and Programming Performance](#) for more information
3. For 1–16 words/1–32 bytes programmed.
4. If a program suspend command is issued within t_{POLL}, the device requires t_{POLL} before reading status data, once programming resumes (that is, the program resume command has been written). If the suspend command was issued after t_{POLL}, status data is available immediately after programming resumes. See [Figure 24](#).

Alternate CE# Controlled Erase and Program Operations-S29GL064M

Parameter		Description	Speed Options			Unit	
JEDEC	Std.		90	10	11		
t _{AVAV}	t _{WC}	Write Cycle Time (Note 1)	Min	90	100	110	ns
t _{AVWL}	t _{AS}	Address Setup Time	Min	0			ns
t _{ELAX}	t _{AH}	Address Hold Time	Min	45			ns
t _{DVEH}	t _{DS}	Data Setup Time	Min	35			ns
t _{EHDX}	t _{DH}	Data Hold Time	Min	0			ns
t _{GHEL}	t _{GHEL}	Read Recovery Time Before Write (OE# High to WE# Low)	Min	0			ns
t _{WLLEL}	t _{WS}	WE# Setup Time	Min	0			ns
t _{EHWH}	t _{WH}	WE# Hold Time	Min	0			ns
t _{ELEH}	t _{CP}	CE# Pulse Width	Min	35			ns
t _{EHEL}	t _{CPH}	CE# Pulse Width High	Min	25			ns
t _{WHWH1}	t _{WHWH1}	Write Buffer Program Operation (Notes 2, 3)	Typ	240			μs
		Single Word Program Operation (Note 2)	Typ	60			
		Accelerated Single Word Program Operation (Note 2)	Typ	54			
t _{WHWH2}	t _{WHWH2}	Sector Erase Operation (Note 2)	Typ	0.5			sec
	t _{RH}	RESET# High Time Before Write	Min	50			ns
	t _{POLL}	Program Valid before Status Polling (Note 5)	Max	4			μs

Notes:

1. Not 100% tested.
2. See [Erase and Programming Performance](#) for more information
3. For 1–16 words/1–32 bytes programmed.
4. If a program suspend command is issued within t_{POLL}, the device requires t_{POLL} before reading status data, once programming resumes (that is, the program resume command has been written). If the suspend command was issued after t_{POLL}, status data is available immediately after programming resumes. See [Figure 24](#).

Alternate CE# Controlled Erase and Program Operations-S29GL032M

Parameter		Description	Speed Options			Unit	
JEDEC	Std.		90	10	11		
t _{AVAV}	t _{WC}	Write Cycle Time (Note 1)	Min	90	100	110	ns
t _{AVWL}	t _{AS}	Address Setup Time	Min	0			ns
t _{ELAX}	t _{AH}	Address Hold Time	Min	45			ns
t _{DVEH}	t _{DS}	Data Setup Time	Min	35			ns
t _{EHDX}	t _{DH}	Data Hold Time	Min	0			ns
t _{GHEL}	t _{GHEL}	Read Recovery Time Before Write (OE# High to WE# Low)	Min	0			ns
t _{WLLEL}	t _{WS}	WE# Setup Time	Min	0			ns
t _{EHWH}	t _{WH}	WE# Hold Time	Min	0			ns
t _{ELEH}	t _{CP}	CE# Pulse Width	Min	35			ns
t _{EHEL}	t _{CPH}	CE# Pulse Width High	Min	25			ns
t _{WHWH1}	t _{WHWH1}	Write Buffer Program Operation (Notes 2, 3)	Typ	240			μs
		Single Word Program Operation (Note 2)	Typ	60			
		Accelerated Single Word Program Operation (Note 2)	Typ	54			
t _{WHWH2}	t _{WHWH2}	Sector Erase Operation (Note 2)	Typ	0.5			sec
	t _{RH}	RESET# High Time Before Write	Min	50			ns
	t _{POLL}	Program Valid before Status Polling (Note 4)	Max	4			μs

Notes:

1. Not 100% tested.
2. See [Erase and Programming Performance](#) for more information
3. For 1–16 words/1–32 bytes programmed.
4. If a program suspend command is issued within t_{POLL}, the device requires t_{POLL} before reading status data, once programming resumes (that is, the program resume command has been written). If the suspend command was issued after t_{POLL}, status data is available immediately after programming resumes. See [Figure 24](#).

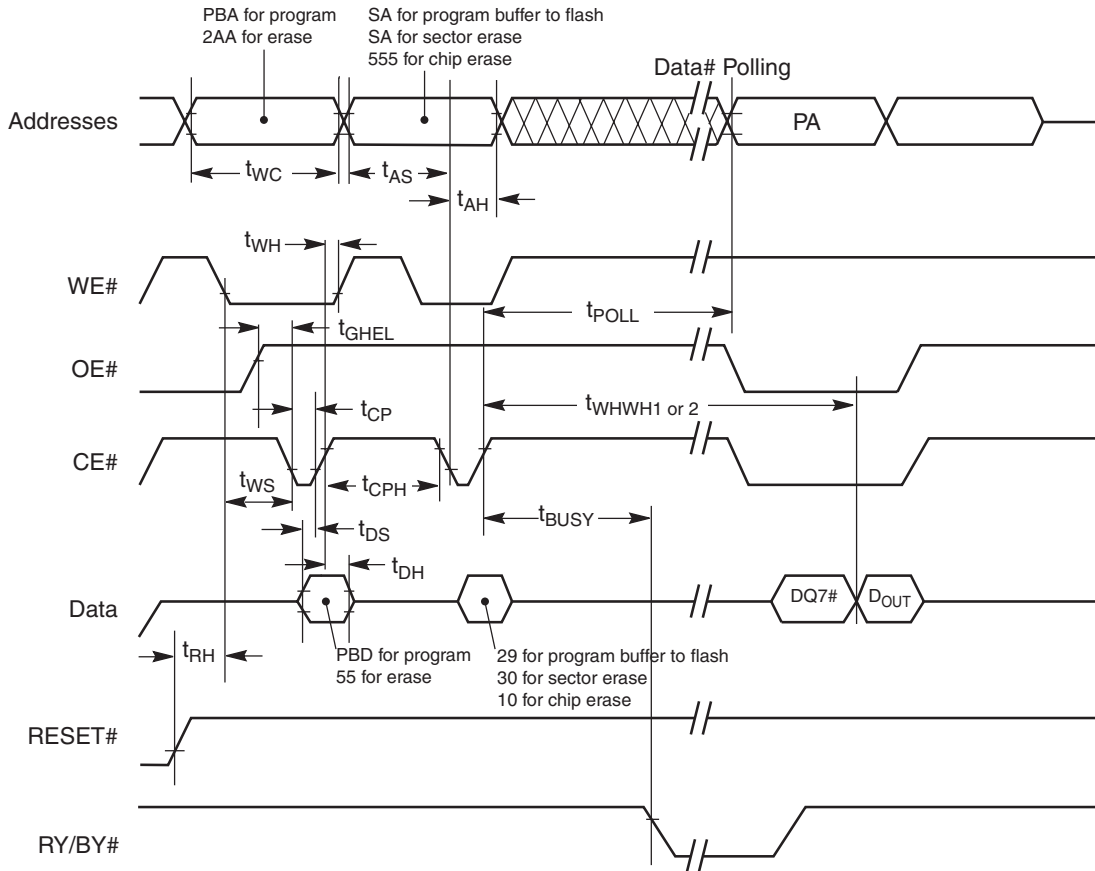

Notes:

1. Figure indicates last two bus cycles of a program or erase operation.
2. PA = program address, SA = sector address, PD = program data.
3. DQ7# is the complement of the data written to the device. DOUT is the data written to the device.
4. Illustration shows device in word mode.

Figure 24. Alternate CE# Controlled Write (Erase/Program) Operation Timings

Erase and Programming Performance

Parameter (Notes)		Typ (Note 1)	Max (Note 2)	Unit	Comments
Sector Erase Time		0.5	3.5	sec	Excludes 00h programming prior to erasure (Note 6)
Chip Erase Time	S29GL032M	32	64	sec	
	S29GL064M	64	128		
	S29GL128M	128	256		
	S29GL256M	256	512		
Total Write Buffer Program Time (3, 5)		240		µs	Excludes system level overhead (Note 7)
Total Accelerated Effective Write Buffer Program Time (4, 5)		200		µs	
Chip Program Time	S29GL032M	31.5		sec	
	S29GL064M	63			
	S29GL128M	126			
	S29GL256M	252			

Notes:

1. Typical program and erase times assume the following conditions: 25°C, V_{CC} = 3.0V, 10,000 cycles; checkerboard data pattern.
2. Under worst case conditions of 90°C: Worst case V_{CC}, 100,000 cycles.
3. Effective programming time (typ) is 15 µs (per word), 7.5 µs (per byte).
4. Effective accelerated programming time (typ) is 12.5 µs (per word), 6.3 µs (per byte).
5. Effective write buffer specification is calculated on a per-word/per-byte basis for a 16-word/32-byte write buffer operation.
6. In the pre-programming step of the Embedded Erase algorithm, all bits are programmed to 00h before erasure.
7. System-level overhead is the time required to execute the command sequence(s) for the program command. See Table 35 and Table 36 for further information on command definitions.

TSOP Pin and BGA Package Capacitance

For package types TA, TF, BA, BF, FA, FF (refer to Ordering Information Pages):

Parameter Symbol	Parameter Description	Test Setup	Typ	Max	Unit	
C _{IN}	Input Capacitance	V _{IN} = 0	TSOP	6	7.5	pF
			BGA	4.2	5.0	pF
C _{OUT}	Output Capacitance	V _{OUT} = 0	TSOP	8.5	12	pF
			BGA	5.4	6.5	pF
C _{IN2}	Control Pin Capacitance	V _{IN} = 0	TSOP	7.5	9	pF
			BGA	3.9	4.7	pF

For package types TB, TC, BB, BC, (refer to Ordering Information Pages):

Parameter Symbol	Parameter Description	Test Setup	Typ	Max	Unit	
C _{IN}	Input Capacitance	V _{IN} = 0	TSOP	8	10	pF
			BGA	8	10	pF
C _{OUT}	Output Capacitance	V _{OUT} = 0	TSOP	8.5	12	pF
			BGA	8.5	12	pF
C _{IN2}	Control Pin Capacitance	V _{IN} = 0	TSOP	8	10	pF
			BGA	8	10	pF
C _{IN3}	RESET# and WP#/ACC Pin Capacitance	V _{IN} = 0	TSOP	20	25	pF
			BGA	15	20	pF

Notes:

1. Sampled, not 100% tested.
2. Test conditions T_A = 25°C, f = 1.0 MHz.

Physical Dimensions

TSR040—40-Pin Standard/Reverse Thin Small Outline Package (TSOP)

REVERSE PIN OUT (TOP VIEW)

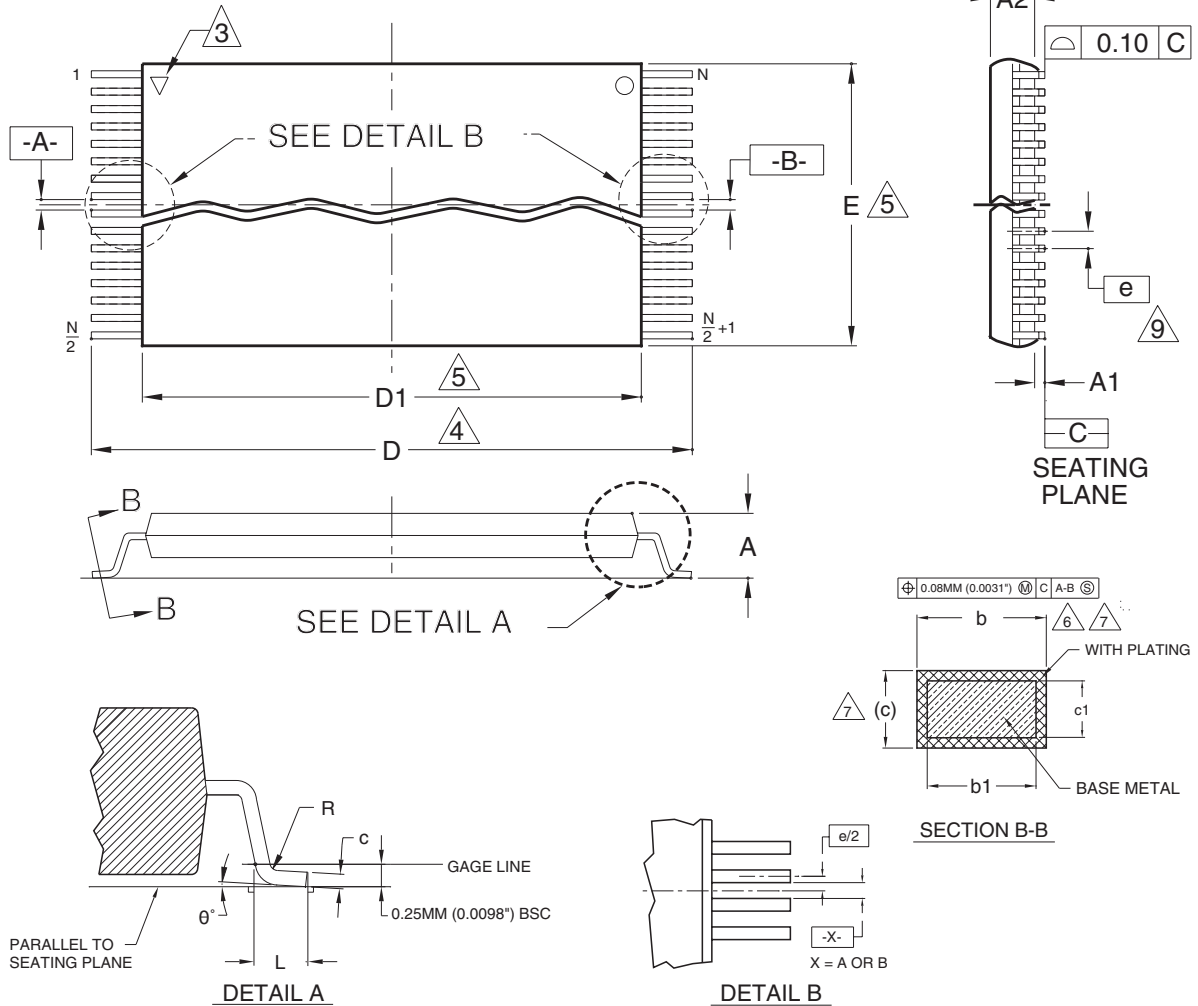

Package	TSR 040		
Jedec	MO-142 (B) EC		
Symbol	MIN	NOM	MAX
A	—	—	1.20
A1	0.05	—	0.15
A2	0.95	1.00	1.05
b1	0.17	0.20	0.23
b	0.17	0.22	0.27
c1	0.10	—	0.16
c	0.10	—	0.21
D	19.80	20.00	20.20
D1	18.30	18.40	18.50
E	9.90	10.00	10.10
e	0.50 BASIC		
L	0.50	0.60	0.70
θ	0°	3°	5°
R	0.08	—	0.20
N	40		

- NOTES:
- ① CONTROLLING DIMENSIONS ARE IN MILLIMETERS (MM). (DIMENSIONING AND TOLERANCING CONFORMS TO ANSI Y14.5M-1982)
 - ② NOT APPLICABLE.
 - ③ PIN 1 IDENTIFIER FOR REVERSE PIN OUT (DIE DOWN), INK OR LASER MARK.
 - ④ TO BE DETERMINED AT THE SEATING PLANE [C-C]. THE SEATING PLANE IS DEFINED AS THE PLANE OF CONTACT THAT IS MADE WHEN THE PACKAGE LEADS ARE ALLOWED TO REST FREELY ON A FLAT HORIZONTAL SURFACE.
 - ⑤ DIMENSIONS D1 AND E DO NOT INCLUDE MOLD PROTRUSION. ALLOWABLE MOLD PROTRUSION IS 0.15MM (.0059") PER SIDE.
 - ⑥ DIMENSION b DOES NOT INCLUDE DAMBAR PROTRUSION. ALLOWABLE DAMBAR PROTRUSION SHALL BE 0.08 (0.0031") TOTAL IN EXCESS OF b DIMENSION AT MAX. MATERIAL CONDITION. MINIMUM SPACE BETWEEN PROTRUSION AND AN ADJACENT LEAD TO BE 0.07 (0.0028").
 - ⑦ THESE DIMENSIONS APPLY TO THE FLAT SECTION OF THE LEAD BETWEEN 0.10MM (.0039") AND 0.25MM (0.0098") FROM THE LEAD TIP.
 - ⑧ LEAD COPLANARITY SHALL BE WITHIN 0.10MM (0.004") AS MEASURED FROM THE SEATING PLANE.
 - ⑨ DIMENSION "e" IS MEASURED AT THE CENTERLINE OF THE LEADS.

3324 \ 16-038.10a

Physical Dimensions

TS048—48-Pin Standard/Reverse Thin Small Outline Package (TSOP)

STANDARD PIN OUT (TOP VIEW)

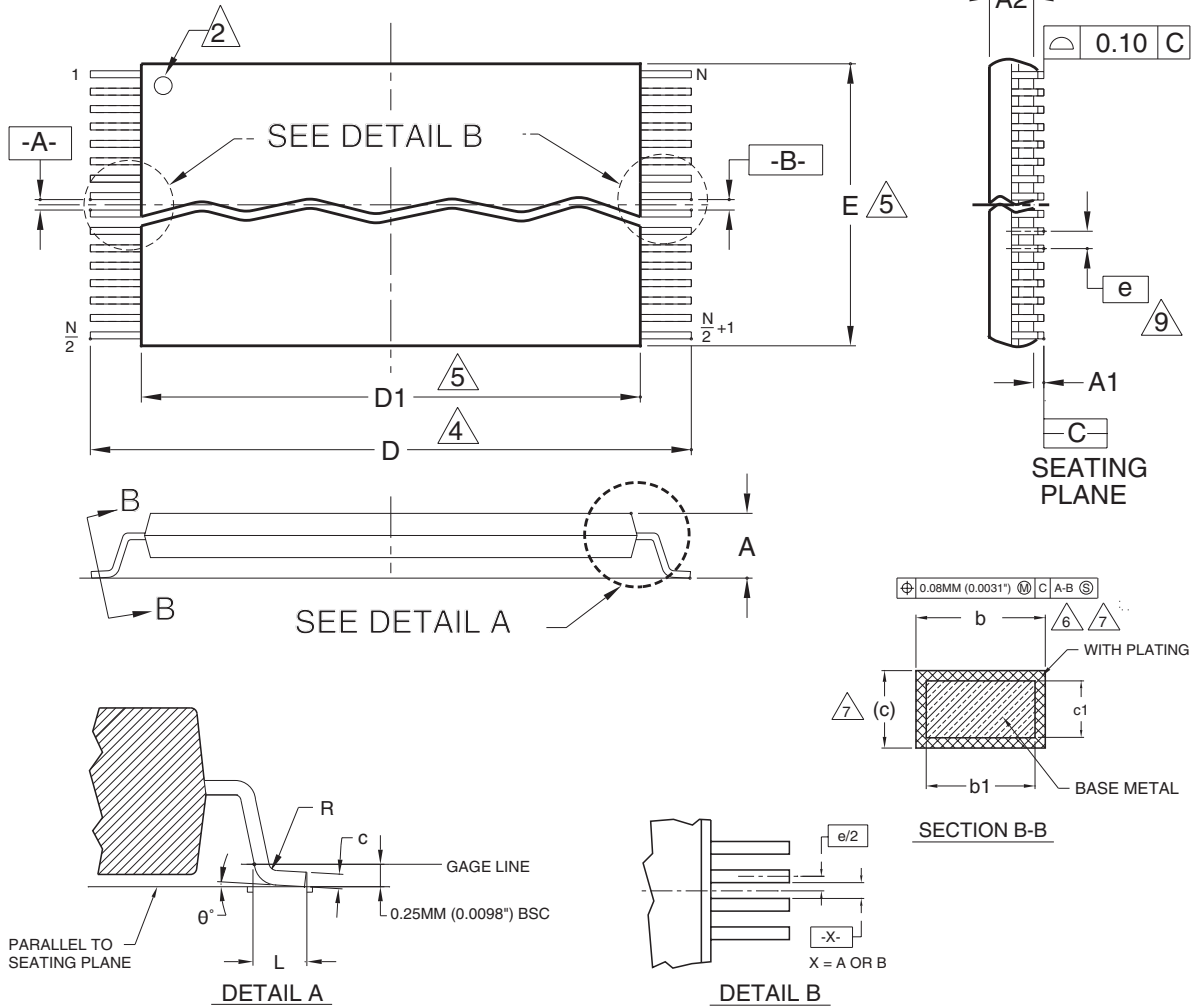

Package	TS 048		
Jedec	MO-142 (B) EC		
Symbol	MIN	NOM	MAX
A	—	—	1.20
A1	0.05	—	0.15
A2	0.95	1.00	1.05
b1	0.17	0.20	0.23
b	0.17	0.22	0.27
c1	0.10	—	0.16
c	0.10	—	0.21
D	19.80	20.00	20.20
D1	18.30	18.40	18.50
E	11.90	12.00	12.10
e	0.50 BASIC		
L	0.50	0.60	0.70
0	0°	3°	5°
R	0.08	—	0.20
N	48		

NOTES:

- ① CONTROLLING DIMENSIONS ARE IN MILLIMETERS (MM). (DIMENSIONING AND TOLERANCING CONFORMS TO ANSI Y14.5M-1982)
- ② PIN 1 IDENTIFIER FOR STANDARD PIN OUT (DIE UP).
- ③ NOT APPLICABLE.
- ④ TO BE DETERMINED AT THE SEATING PLANE [C]. THE SEATING PLANE IS DEFINED AS THE PLANE OF CONTACT THAT IS MADE WHEN THE PACKAGE LEADS ARE ALLOWED TO REST FREELY ON A FLAT HORIZONTAL SURFACE.
- ⑤ DIMENSIONS D1 AND E DO NOT INCLUDE MOLD PROTRUSION. ALLOWABLE MOLD PROTRUSION IS 0.15MM (.0059") PER SIDE.
- ⑥ DIMENSION b DOES NOT INCLUDE DAMBAR PROTRUSION. ALLOWABLE DAMBAR PROTRUSION SHALL BE 0.08 (0.0031") TOTAL IN EXCESS OF b DIMENSION AT MAX. MATERIAL CONDITION. MINIMUM SPACE BETWEEN PROTRUSION AND AN ADJACENT LEAD TO BE 0.07 (0.0028").
- ⑦ THESE DIMENSIONS APPLY TO THE FLAT SECTION OF THE LEAD BETWEEN 0.10MM (.0039") AND 0.25MM (0.0098") FROM THE LEAD TIP.
- ⑧ LEAD COPLANARITY SHALL BE WITHIN 0.10MM (0.004") AS MEASURED FROM THE SEATING PLANE.
- ⑨ DIMENSION "e" IS MEASURED AT THE CENTERLINE OF THE LEADS.

3325 \ 16-038.10a

Physical Dimensions

TSR048—48-Pin Standard/Reverse Thin Small Outline Package (TSOP)

REVERSE PIN OUT (TOP VIEW)

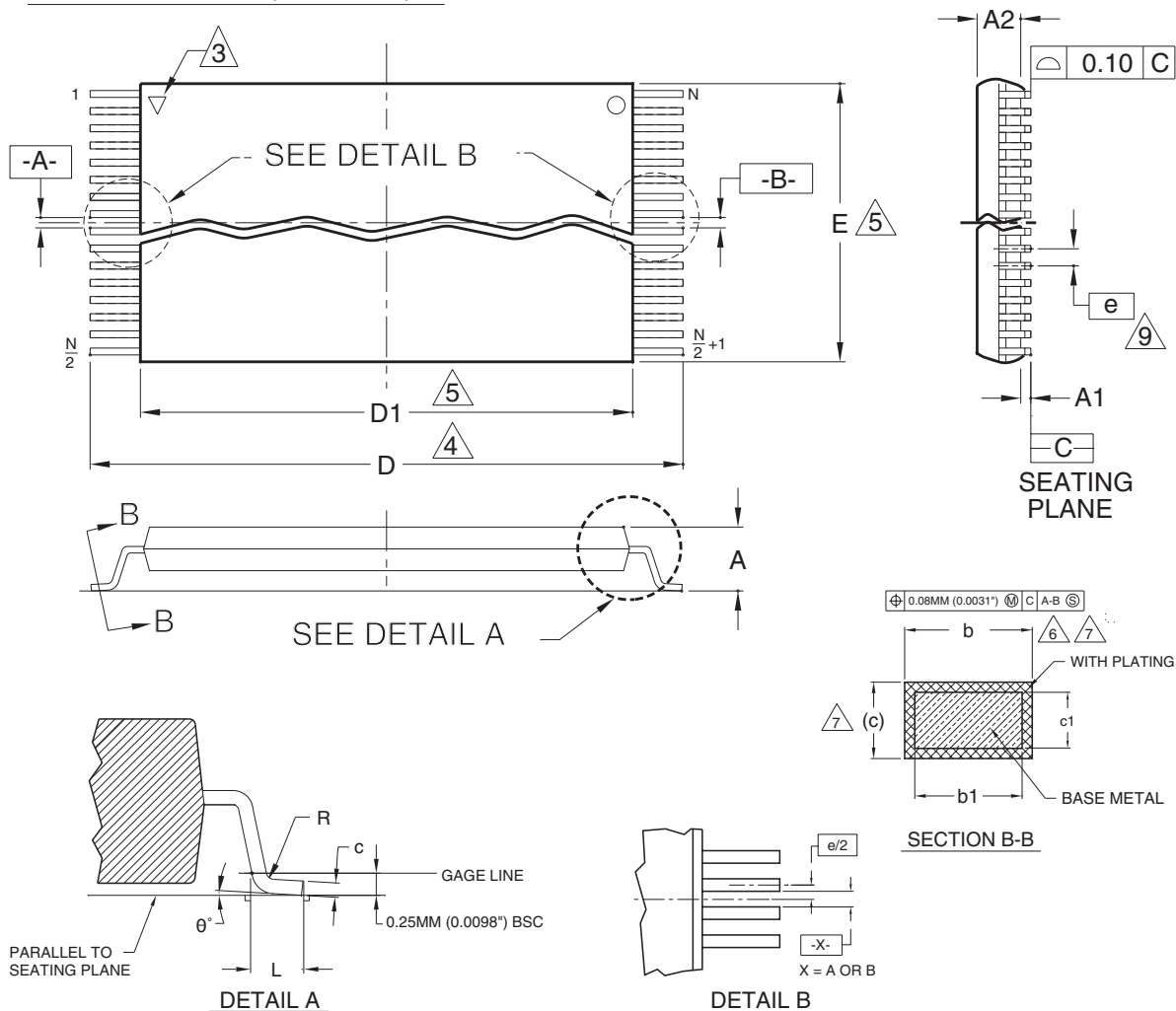

Package	TSR 048		
Jedec	MO-142 (B) EC		
Symbol	MIN	NOM	MAX
A	—	—	1.20
A1	0.05	—	0.15
A2	0.95	1.00	1.05
b1	0.17	0.20	0.23
b	0.17	0.22	0.27
c1	0.10	—	0.16
c	0.10	—	0.21
D	19.80	20.00	20.20
D1	18.30	18.40	18.50
E	11.90	12.00	12.10
e	0.50 BASIC		
L	0.50	0.60	0.70
θ	0°	3°	5°
R	0.08	—	0.20
N	48		

NOTES:

- ① CONTROLLING DIMENSIONS ARE IN MILLIMETERS (MM). (DIMENSIONING AND TOLERANCING CONFORMS TO ANSI Y14.5M-1982)
- ② NOT APPLICABLE.
- ③ PIN 1 IDENTIFIER FOR REVERSE PIN OUT (DIE DOWN), INK OR LASER MARK.
- ④ TO BE DETERMINED AT THE SEATING PLANE [C]. THE SEATING PLANE IS DEFINED AS THE PLANE OF CONTACT THAT IS MADE WHEN THE PACKAGE LEADS ARE ALLOWED TO REST FREELY ON A FLAT HORIZONTAL SURFACE.
- ⑤ DIMENSIONS D1 AND E DO NOT INCLUDE MOLD PROTRUSION. ALLOWABLE MOLD PROTRUSION IS 0.15MM (.0059") PER SIDE.
- ⑥ DIMENSION b DOES NOT INCLUDE DAMBAR PROTRUSION. ALLOWABLE DAMBAR PROTRUSION SHALL BE 0.08 (0.0031") TOTAL IN EXCESS OF b DIMENSION AT MAX. MATERIAL CONDITION. MINIMUM SPACE BETWEEN PROTRUSION AND AN ADJACENT LEAD TO BE 0.07 (0.0028").
- ⑦ THESE DIMENSIONS APPLY TO THE FLAT SECTION OF THE LEAD BETWEEN 0.10MM (.0039") AND 0.25MM (0.0098") FROM THE LEAD TIP.
- ⑧ LEAD COPLANARITY SHALL BE WITHIN 0.10MM (0.004") AS MEASURED FROM THE SEATING PLANE.
- ⑨ DIMENSION "e" IS MEASURED AT THE CENTERLINE OF THE LEADS.

3326 \ 16-038.10a

Physical Dimensions

TS056/TSR056—56-Pin Standard/Reverse Thin Small Outline Package (TSOP)

STANDARD PIN OUT (TOP VIEW)

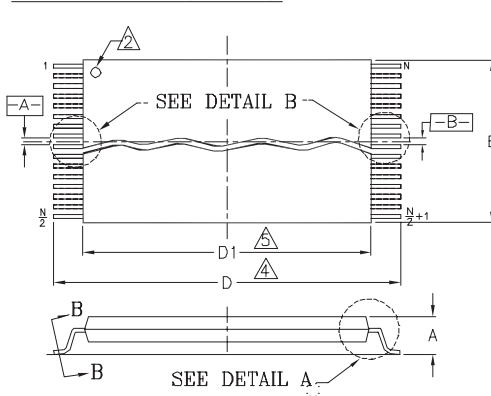

REVERSE PIN OUT (TOP VIEW)

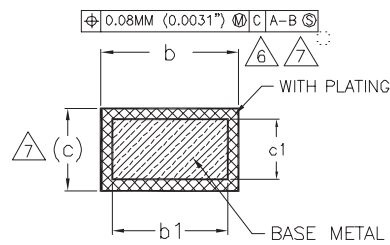
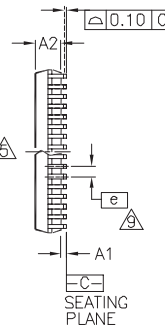
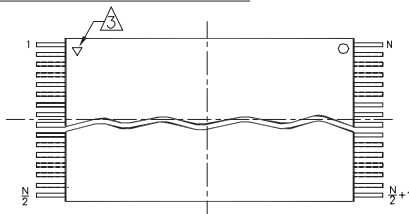

SECTION B-B

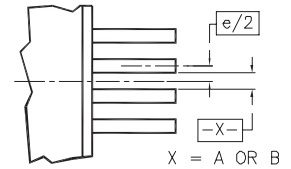

DETAIL B

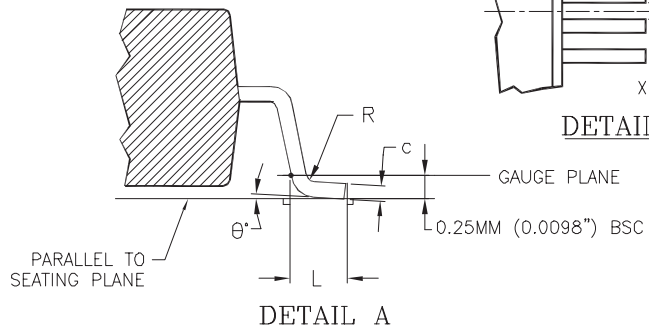

DETAIL A

PACKAGE	TS/TSR 56		
JEDEC	MO-142 (B) EC		
SYMBOL	MIN.	NOM.	MAX.
A	---	---	1.20
A1	0.05	---	0.15
A2	0.95	1.00	1.05
b1	0.17	0.20	0.23
b	0.17	0.22	0.27
c1	0.10	---	0.16
c	0.10	---	0.21
D	19.90	20.00	20.20
D1	18.30	18.40	18.50
E	13.90	14.00	14.10
e	0.50 BASIC		
L	0.50	0.60	0.70
∅	0°	3°	5°
R	0.08	---	0.20
N	56		

NOTES:

- 1 CONTROLLING DIMENSIONS ARE IN MILLIMETERS (mm). (DIMENSIONING AND TOLERANCING CONFORMS TO ANSI Y14.5M-1982.)
- 2 PIN 1 IDENTIFIER FOR STANDARD PIN OUT (DIE UP).
- 3 PIN 1 IDENTIFIER FOR REVERSE PIN OUT (DIE DOWN), INK OR LASER MARK.
- 4 TO BE DETERMINED AT THE SEATING PLANE [C]. THE SEATING PLANE IS DEFINED AS THE PLANE OF CONTACT THAT IS MADE WHEN THE PACKAGE LEADS ARE ALLOWED TO REST FREELY ON A FLAT HORIZONTAL SURFACE.
- 5 DIMENSIONS D1 AND E DO NOT INCLUDE MOLD PROTRUSION. ALLOWABLE MOLD PROTRUSION IS 0.15 mm PER SIDE.
- 6 DIMENSION b DOES NOT INCLUDE DAMBAR PROTRUSION. ALLOWABLE DAMBAR PROTRUSION SHALL BE 0.08 mm TOTAL IN EXCESS OF b DIMENSION AT MAX MATERIAL CONDITION. MINIMUM SPACE BETWEEN PROTRUSION AND AN ADJACENT LEAD TO BE 0.07 mm.
- 7 THESE DIMENSIONS APPLY TO THE FLAT SECTION OF THE LEAD BETWEEN 0.10 mm AND 0.25 mm FROM THE LEAD TIP.
- 8 LEAD COPLANARITY SHALL BE WITHIN 0.10 mm AS MEASURED FROM THE SEATING PLANE.
- 9 DIMENSION "e" IS MEASURED AT THE CENTERLINE OF THE LEADS.

3160/38.10A

Physical Dimensions

LAA064—64-Ball Fortified Ball Grid Array (FBGA)

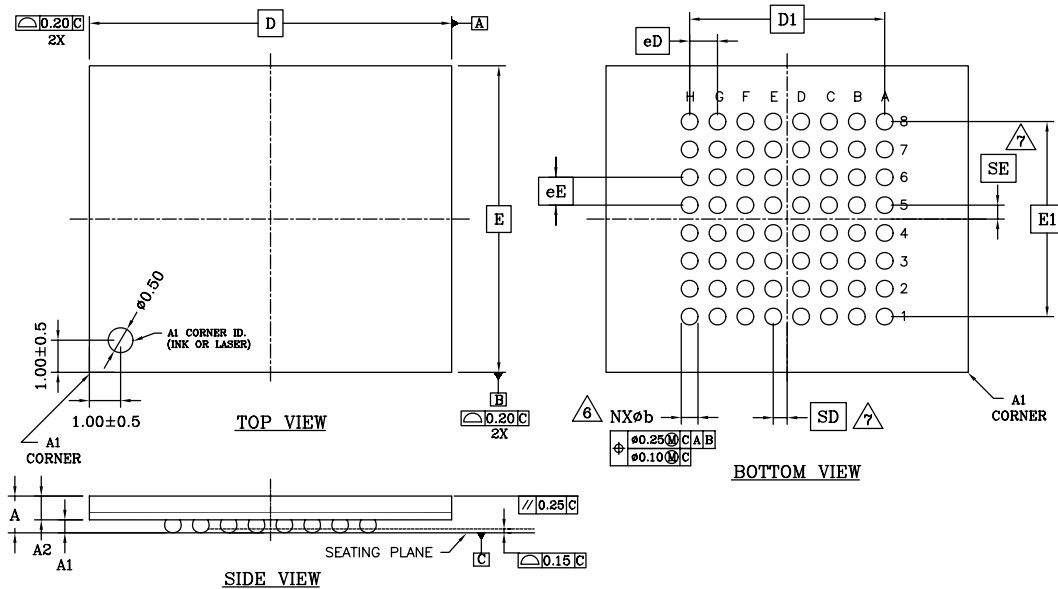

PACKAGE	LAA 064			
JEDEC	N/A			
	13.00x11.00 mm PACKAGE			
SYMBOL	MIN.	NOM.	MAX.	NOTE
A	—	—	1.40	PROFILE HEIGHT
A1	0.40	—	—	STANDOFF
A2	0.60	—	—	BODY THICKNESS
D	13.00 BSC.			BODY SIZE
E	11.00 BSC.			BODY SIZE
D1	7.00 BSC.			MATRIX FOOTPRINT
E1	7.00 BSC.			MATRIX FOOTPRINT
MD	8			MATRIX SIZE D DIRECTION
ME	8			MATRIX SIZE E DIRECTION
N	64			BALL COUNT
φb	0.50	0.60	0.70	BALL DIAMETER
φD	1.00 BSC.			BALL PITCH - D DIRECTION
φE	1.00 BSC.			BALL PITCH - E DIRECTION
SD/SE	0.50 BSC.			SOLDER BALL PLACEMENT
	A1—A8, K1—K8			DEPOPULATED SOLDER BALLS

NOTES:

- DIMENSIONING AND TOLERANCING METHODS PER ASME Y14.5M-1994 .
- ALL DIMENSIONS ARE IN MILLIMETERS .
- BALL POSITION DESIGNATION PER JESD 95-1, SPP-010 (EXCEPT AS NOTED).
- ⓔ REPRESENTS THE SOLDER BALL GRID PITCH .
- SYMBOL "MD" IS THE BALL MATRIX SIZE IN THE "D" DIRECTION.
SYMBOL "ME" IS THE BALL COLUMN MATRIX SIZE IN THE "E" DIRECTION.
N IS THE NUMBER OF POPULATED SOLDER BALL POSITIONS FOR MATRIX SIZE MD X ME.
- ⓐ DIMENSION "b" IS MEASURED AT THE MAXIMUM BALL DIAMETER IN A PLANE PARALLEL TO DATUM "C".
- Ⓩ SD AND SE ARE MEASURED WITH RESPECT TO DATUMS A AND B AND DEFINE THE POSITION OF THE CENTER SOLDER BALL IN THE OUTER ROW.
WHEN THERE IS AN ODD NUMBER OF SOLDER BALLS IN THE OUTER ROW, SD OR SE = 0.000.
WHEN THERE IS AN EVEN NUMBER OF SOLDER BALLS IN THE OUTER ROW, SD OR SE = ⓔ/2
- "X" IN THE PACKAGE VARIATIONS DENOTES PART IS UNDER QUALIFICATION.
- "+" INDICATES THE THEORETICAL CENTER OF DEPOPULATED BALLS.

Physical Dimensions

LAC064—64-Pin I8 x I2 mm Package

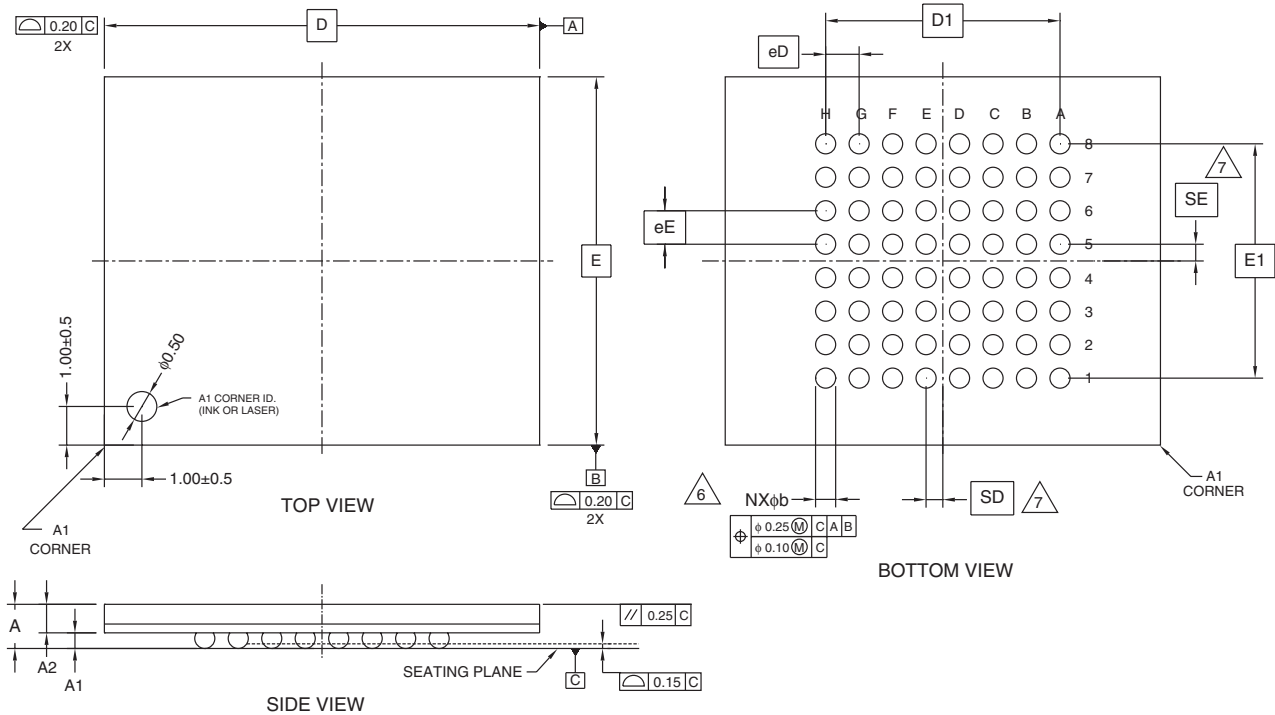

PACKAGE	LAC 064			NOTE
JEDEC	N/A			
18.00 mm x 12.00 mm PACKAGE				
SYMBOL	MIN	NOM	MAX	NOTE
A	---	---	1.40	PROFILE HEIGHT
A1	0.40	---	---	STANDOFF
A2	0.60	---	---	BODY THICKNESS
D	18.00 BSC.			BODY SIZE
E	12.00 BSC.			BODY SIZE
D1	7.00 BSC.			MATRIX FOOTPRINT
E1	7.00 BSC.			MATRIX FOOTPRINT
MD	8			MATRIX SIZE D DIRECTION
ME	8			MATRIX SIZE E DIRECTION
N	64			BALL COUNT
φb	0.50	0.60	0.70	BALL DIAMETER
eD	1.00 BSC.			BALL PITCH - D DIRECTION
eE	1.00 BSC.			BALL PITCH - E DIRECTION
SD / SE	0.50 BSC.			SOLDER BALL PLACEMENT
	NONE			DEPOPULATED SOLDER BALLS

NOTES:

- DIMENSIONING AND TOLERANCING PER ASME Y14.5M-1994.
- ALL DIMENSIONS ARE IN MILLIMETERS.
- BALL POSITION DESIGNATION PER JESD 95-1, SPP-010 (EXCEPT AS NOTED).
- [e] REPRESENTS THE SOLDER BALL GRID PITCH.
- SYMBOL "MD" IS THE BALL ROW MATRIX SIZE IN THE "D" DIRECTION.
SYMBOL "ME" IS THE BALL COLUMN MATRIX SIZE IN THE "E" DIRECTION.
N IS THE TOTAL NUMBER OF SOLDER BALLS.
- [6] DIMENSION "b" IS MEASURED AT THE MAXIMUM BALL DIAMETER IN A PLANE PARALLEL TO DATUM C.
- [7] SD AND SE ARE MEASURED WITH RESPECT TO DATUMS A AND B AND DEFINE THE POSITION OF THE CENTER SOLDER BALL IN THE OUTER ROW.
WHEN THERE IS AN ODD NUMBER OF SOLDER BALLS IN THE OUTER ROW PARALLEL TO THE D OR E DIMENSION, RESPECTIVELY, SD OR SE = [e]/2.
WHEN THERE IS AN EVEN NUMBER OF SOLDER BALLS IN THE OUTER ROW, SD OR SE = [e/2]
- NOT USED.
- "+" INDICATES THE THEORETICAL CENTER OF DEPOPULATED BALLS.

Physical Dimensions

FBA048—48-Pin 6.15 x 8.15 mm Package

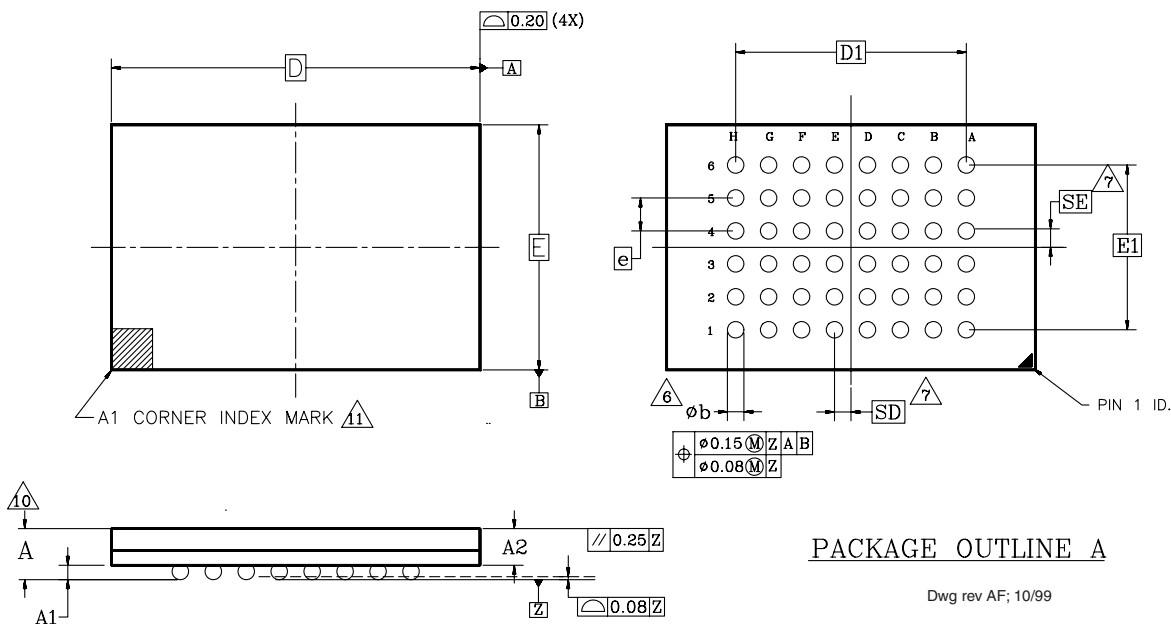

PACKAGE	xFBA 048			NOTE
JEDEC	N/A			
	6.15mmx8.15mm PACKAGE			
SYMBOL	MIN	NOM	MAX	
A	—	—	1.20	OVERALL THICKNESS
A1	0.20	—	—	BALL HEIGHT
A2	0.84	—	0.94	BODY THICKNESS
D	8.15 BSC			BODY SIZE
E	6.15 BSC			BODY SIZE
D1	5.60 BSC			BALL FOOTPRINT
E1	4.00 BSC			BALL FOOTPRINT
MD	8			ROW MATRIX SIZE D DIRECTION
ME	6			ROW MATRIX SIZE E DIRECTION
N	48			TOTAL BALL COUNT
b	0.25	0.30	0.35	BALL DIAMETER
e	0.80 BSC			BALL PITCH
SD/SE	0.40 BSC			SOLDER BALL PLACEMENT

NOTES:

- DIMENSIONING AND TOLERANCING PER ASME Y14.5M-1994.
- ALL DIMENSIONS ARE IN MILLIMETERS.
- BALL POSITION DESIGNATION PER JESD 95-1, SPP-010.
- [e] REPRESENTS THE SOLDER BALL GRID PITCH.
- SYMBOL "MD" IS THE BALL ROW MATRIX SIZE IN THE "D" DIRECTION. SYMBOL "ME" IS THE BALL COLUMN MATRIX SIZE IN THE "E" DIRECTION. N IS THE MAXIMUM NUMBER OF SOLDER BALLS FOR MATRIX SIZE MD x ME.
- DIMENSION "b" IS MEASURED AT THE MAXIMUM BALL DIAMETER IN A PLANE PARALLEL TO DATUM Z.
- SD AND SE ARE MEASURED WITH RESPECT TO DATUMS A AND B AND DEFINE THE POSITION OF THE CENTER SOLDER BALL IN THE OUTER ROW. WHEN THERE IS AN ODD NUMBER OF SOLDER BALLS IN THE OUTER ROW PARALLEL TO THE D OR E DIMENSION, RESPECTIVELY, SD OR SE = 0.000 WHEN THERE IS AN EVEN NUMBER OF SOLDER BALLS IN THE OUTER ROW, SD OR SE = $\frac{e}{2}$
- "X" IN THE PACKAGE VARIATIONS DENOTES PART IS UNDER QUALIFICATION.
- "+" IN THE PACKAGE DRAWING INDICATE THE THEORETICAL CENTER OF DEPOPULATED BALLS.
- FOR PACKAGE THICKNESS A IS THE CONTROLLING DIMENSION.
- A1 CORNER TO BE IDENTIFIED BY CHAMFER, INK MARK, METALLIZED MARKINGS INDENTATION OR OTHER MEANS.

Physical Dimensions

FBC048—48-Pin 8 x 9 mm Package

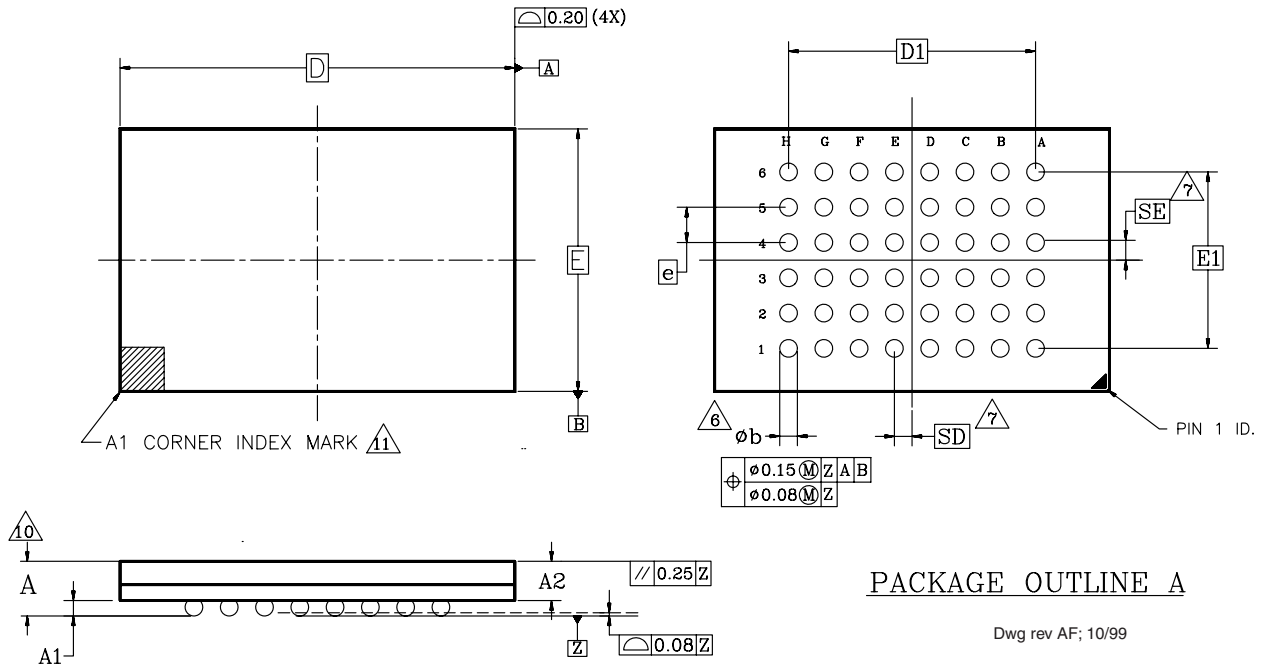

PACKAGE	FBC 048			NOTE
JEDEC	N/A			
8.00mmx9.00mm PACKAGE				
SYMBOL	MIN	NOM	MAX	NOTE
A	—	—	1.20	OVERALL THICKNESS
A1	0.20	—	—	BALL HEIGHT
A2	0.84	—	0.94	BODY THICKNESS
D	9.00 BSC			BODY SIZE
E	8.00 BSC			BODY SIZE
D1	5.60 BSC			BALL FOOTPRINT
E1	4.00 BSC			BALL FOOTPRINT
MD	8			ROW MATRIX SIZE D DIRECTION
ME	6			ROW MATRIX SIZE E DIRECTION
N	48			TOTAL BALL COUNT
b	0.25	0.30	0.35	BALL DIAMETER
e	0.80 BSC			BALL PITCH
SD/SE	0.40 BSC			SOLDER BALL PLACEMENT

NOTES:

- DIMENSIONING AND TOLERANCING PER ASME Y14.5M-1994.
- ALL DIMENSIONS ARE IN MILLIMETERS.
- BALL POSITION DESIGNATION PER JESD 95-1, SPP-010.
- \square REPRESENTS THE SOLDER BALL GRID PITCH.
- SYMBOL "MD" IS THE BALL ROW MATRIX SIZE IN THE "D" DIRECTION. SYMBOL "ME" IS THE BALL COLUMN MATRIX SIZE IN THE "E" DIRECTION. N IS THE MAXIMUM NUMBER OF SOLDER BALLS FOR MATRIX SIZE MD x ME.
- $\triangle 6$ DIMENSION "b" IS MEASURED AT THE MAXIMUM BALL DIAMETER IN A PLANE PARALLEL TO DATUM Z.
- $\triangle 7$ SD AND SE ARE MEASURED WITH RESPECT TO DATUMS A AND B AND DEFINE THE POSITION OF THE CENTER SOLDER BALL IN THE OUTER ROW. WHEN THERE IS AN ODD NUMBER OF SOLDER BALLS IN THE OUTER ROW PARALLEL TO THE D OR E DIMENSION, RESPECTIVELY, SD OR SE = 0.000 WHEN THERE IS AN EVEN NUMBER OF SOLDER BALLS IN THE OUTER ROW, SD OR SE = $\square e/2$
- "X" IN THE PACKAGE VARIATIONS DENOTES PART IS UNDER QUALIFICATION.
- "+" IN THE PACKAGE DRAWING INDICATE THE THEORETICAL CENTER OF DEPOPULATED BALLS.
- $\triangle 10$ FOR PACKAGE THICKNESS A IS THE CONTROLLING DIMENSION.
- $\triangle 11$ A1 CORNER TO BE IDENTIFIED BY CHAMFER, INK MARK, METALLIZED MARKINGS INDENTION OR OTHER MEANS.

Physical Dimensions

FBE063—63-Pin I2 x II mm Package

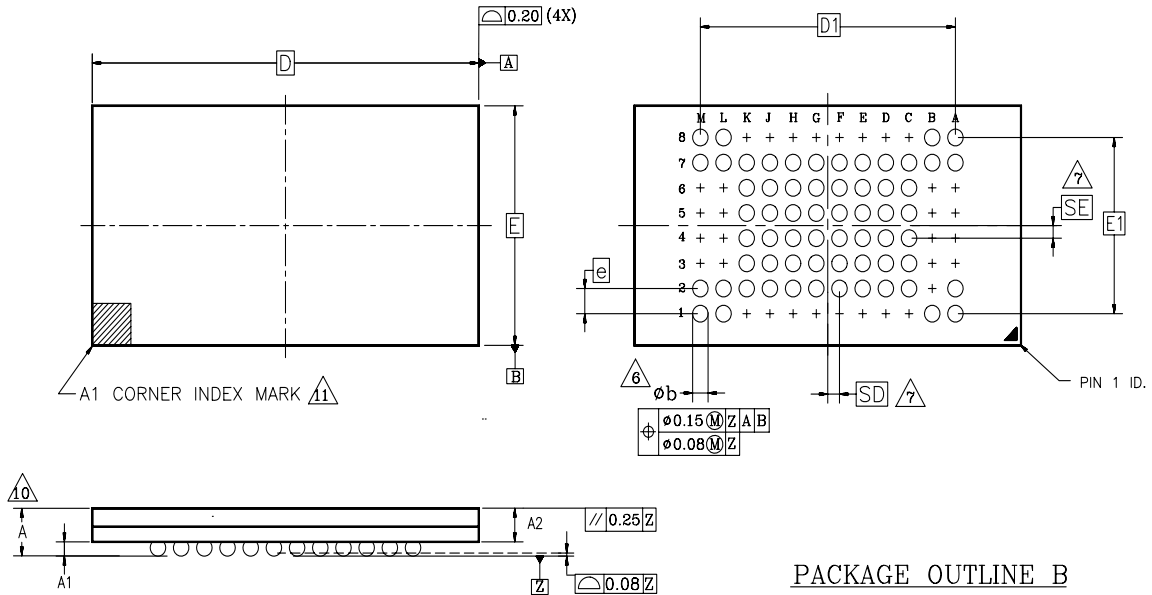

PACKAGE OUTLINE B

Dwg rev AF; 10/99

PACKAGE	xFBE 063			
JEDEC	N/A			
	12.00mmx11.00mm PACKAGE			
SYMBOL	MIN	NOM	MAX	NOTE
A	-	-	1.20	OVERALL THICKNESS
A1	0.20	-	-	BALL HEIGHT
A2	0.84	-	0.94	BODY THICKNESS
D	12.00 BSC			BODY SIZE
E	11.00 BSC			BODY SIZE
D1	8.80 BSC			BALL FOOTPRINT
E1	5.60 BSC			BALL FOOTPRINT
MD	12			ROW MATRIX SIZE D DIRECTION
ME	8			ROW MATRIX SIZE E DIRECTION
N	63			TOTAL BALL COUNT
b	0.25	0.30	0.35	BALL DIAMETER
e	0.80 BSC			BALL PITCH
SD/SE	0.40 BSC			SOLDER BALL PLACEMENT
	A3-A6, B2-B6 L3-L6, M3-M6 C1-K1, C8-K8			DEPOPULATED SOLDER BALLS

NOTES:

- DIMENSIONING AND TOLERANCING PER ASME Y14.5M-1994.
- ALL DIMENSIONS ARE IN MILLIMETERS.
- BALL POSITION DESIGNATION PER JESD 95-1, SPP-010.
- [e] REPRESENTS THE SOLDER BALL GRID PITCH.
- SYMBOL "MD" IS THE BALL ROW MATRIX SIZE IN THE "D" DIRECTION. SYMBOL "ME" IS THE BALL COLUMN MATRIX SIZE IN THE "E" DIRECTION. N IS THE MAXIMUM NUMBER OF SOLDER BALLS FOR MATRIX SIZE MD x ME.
- [6] DIMENSION "b" IS MEASURED AT THE MAXIMUM BALL DIAMETER IN A PLANE PARALLEL TO DATUM Z.
- [7] SD AND SE ARE MEASURED WITH RESPECT TO DATUMS A AND B AND DEFINE THE POSITION OF THE CENTER SOLDER BALL IN THE OUTER ROW. WHEN THERE IS AN ODD NUMBER OF SOLDER BALLS IN THE OUTER ROW PARALLEL TO THE D OR E DIMENSION, RESPECTIVELY, SD OR SE = 0.000 WHEN THERE IS AN EVEN NUMBER OF SOLDER BALLS IN THE OUTER ROW, SD OR SE = $e/2$
- "X" IN THE PACKAGE VARIATIONS DENOTES PART IS UNDER QUALIFICATION.
- "+" IN THE PACKAGE DRAWING INDICATE THE THEORETICAL CENTER OF DEPOPULATED BALLS.
- [10] FOR PACKAGE THICKNESS A IS THE CONTROLLING DIMENSION.
- [11] A1 CORNER TO BE IDENTIFIED BY CHAMFER, INK MARK, METALLIZED MARKINGS INDENTION OR OTHER MEANS.

Physical Dimensions

FPT-48P-MI9

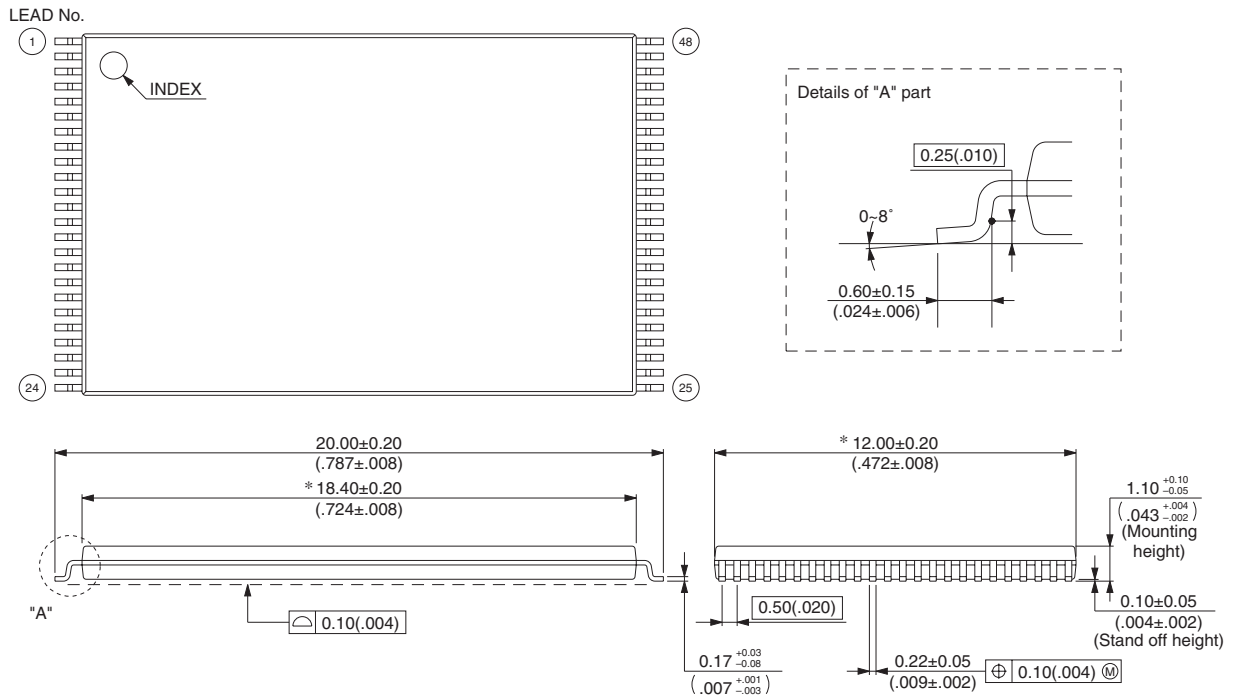

FPT-56P-M01

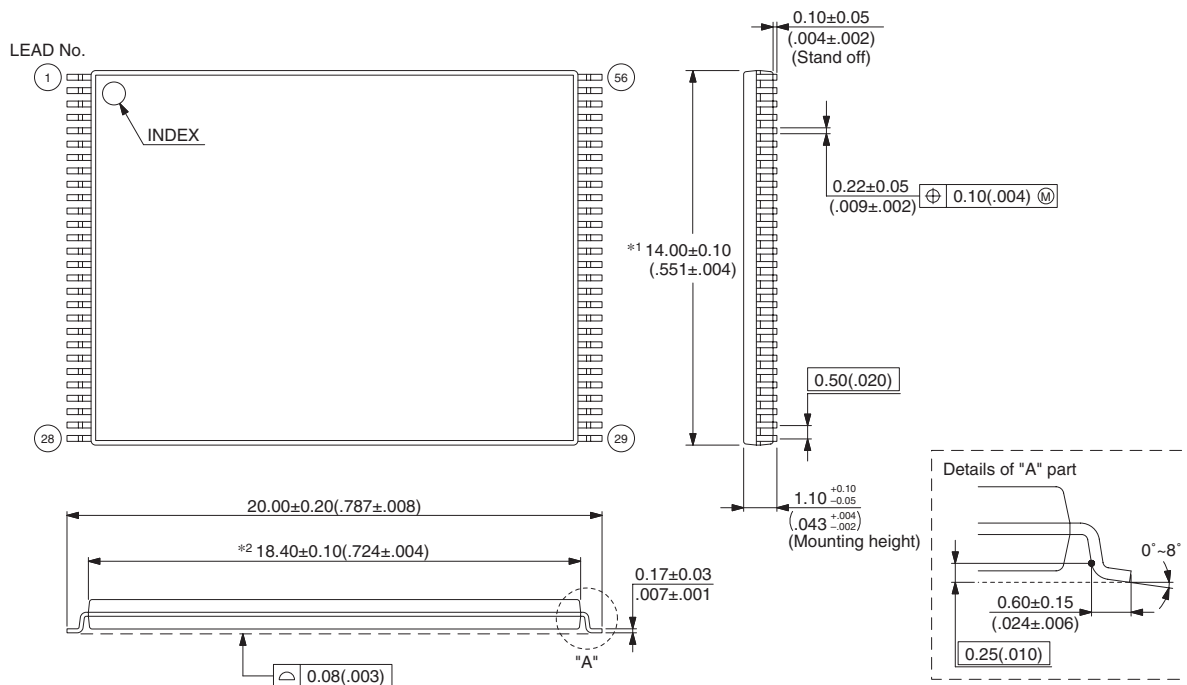

Physical Dimensions

FBG048—48-Pin 8 x 6 mm Package

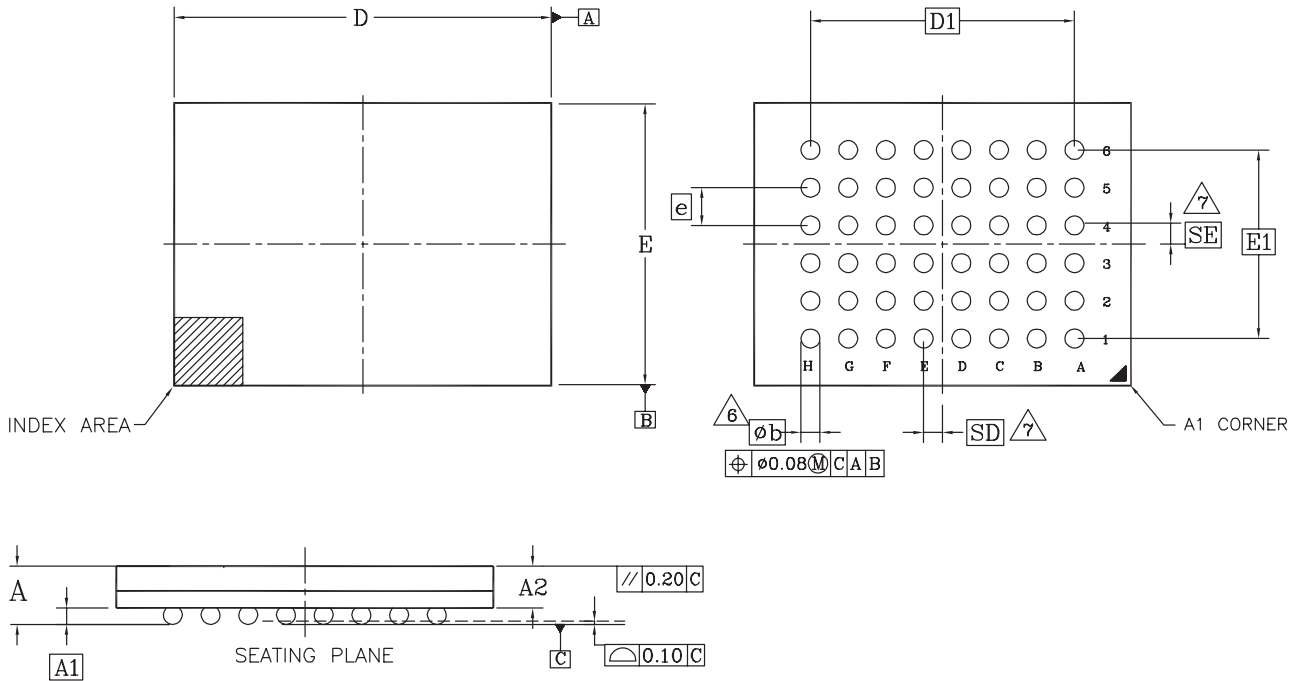

PACKAGE	FBG 048			
JEDEC	N/A			
	8.00 mm x 6.00 mm NOM PACKAGE			
SYMBOL	MIN	NOM	MAX	NOTE
A	0.95	1.08	1.20	OVERALL THICKNESS
A1	0.28	0.38	0.48	BALL HEIGHT
A2	---	---	---	BODY THICKNESS
D	7.80	8.00	8.20	BODY SIZE
E	5.80	6.00	6.20	BODY SIZE
D1	5.60 BSC.			BALL FOOTPRINT
E1	4.00 BSC.			BALL FOOTPRINT
MD	8			ROW MATRIX SIZE D DIRECTION
ME	6			ROW MATRIX SIZE E DIRECTION
N	48			TOTAL BALL COUNT
ϕb	0.40	0.45	0.50	BALL DIAMETER
e	0.80 BSC.			BALL PITCH
SD / SE	0.40 BSC.			SOLDER BALL PLACEMENT
	NONE			DEPOPULATED SOLDER BALLS

NOTES:

- DIMENSIONING AND TOLERANCING PER ASME Y14.5M-1994.
- ALL DIMENSIONS ARE IN MILLIMETERS.
- BALL POSITION DESIGNATION PER JESD 95-1, SPP-010 (EXCEPT AS NOTED).
- e REPRESENTS THE SOLDER BALL GRID PITCH.
- SYMBOL "MD" IS THE BALL ROW MATRIX SIZE IN THE "D" DIRECTION.
SYMBOL "ME" IS THE BALL COLUMN MATRIX SIZE IN THE "E" DIRECTION.
N IS THE TOTAL NUMBER OF SOLDER BALLS.
- 6 DIMENSION "b" IS MEASURED AT THE MAXIMUM BALL DIAMETER IN A PLANE PARALLEL TO DATUM C.
- 7 SD AND SE ARE MEASURED WITH RESPECT TO DATUMS A AND B AND DEFINE THE POSITION OF THE CENTER SOLDER BALL IN THE OUTER ROW.
WHEN THERE IS AN ODD NUMBER OF SOLDER BALLS IN THE OUTER ROW PARALLEL TO THE D OR E DIMENSION, RESPECTIVELY, SD OR SE = 0.000.
WHEN THERE IS AN EVEN NUMBER OF SOLDER BALLS IN THE OUTER ROW, SD OR SE = e/2
- NOT USED.
- "+" INDICATES THE THEORETICAL CENTER OF DEPOPULATED BALLS.
- 10 A1 CORNER TO BE IDENTIFIED BY CHAMFER, LASER OR INK MARK, METALLIZED MARK INDENTATION OR OTHER MEANS.

34221_16-038.9m

Revision Summary

Revision A (January 29, 2004)

Initial Release.

Revision AI (February 23, 2004)

Connection Diagrams

Removed 80-ball Fine-pitch BGA pinout.

Ordering Information

Added additional packing type.

Removed frame description from package material set.

Updated valid combinations to reflect the addition of new package type.

Added marking descriptions to all valid combination tables.

Word Program Command Sequence and Unlock Bypass Command Sequence

Added these sections.

Figure 3, Write Buffer Programming Operation, Figure 4, Program Operation

Updated figure.

Table 35, "Command Definitions (x16 Mode, BYTE# = VIH)," on page 64

Updated table.

Added note 19.

Table 36, "Command Definitions (x8 Mode, BYTE# = VIL)," on page 65

Updated table.

Added note 17.

Figure 7, Data# Polling Algorithm

Updated figure.

Erase and Program Operations and Alternate CE# Controlled Erase and Program Operations

Updated T_{WHWHI} description

Added Note 4.

Figure 16, Figure 18, Figure 20, Figure 24

Updated figure.

Physical Dimensions

Removed BGA-63P-M02 and BGA-80P-M01

Added the TS040 package

Revision A2 (February 25, 2004)

Connection Diagrams

Removed the 40-pin reverse TSOP diagram.

Updated the 48-pin standard TSOP diagram.

Removed the 48-pin reverse TSOP diagram.

Removed the 56-pin reverse TSOP diagram.

Ordering Information

Removed all references to package type R.

Table 18 Autoselect Codes, (High Voltage Method)

Updated the R3, R4 column replacing -04 and -03 designators with -R4 and -R3 respectively.

Word Program Command Sequence

Included statements documenting word programming support for backward compatibility with existing Flash drivers.

Physical Dimensions

Removed the BGA-80P-M02 diagram.

Revision A3 (February 26, 2004)

Distinctive Characteristics

Corrected typo in the Flexible Sector Architecture section.

Revision A4 (March 24, 2004)

CMOS Compatible

Removed V_{CC} from Max for V_{OL} .

Erase and Program Operations-S29GL256M only

Corrected unit typos.

Erase and Program Operations-S29GL128M only

Corrected the minimum Data Setup Time.

Alternate CE# Controlled Erase and Program Operations-S29GL128M

Corrected the minimum CE# Pulse width.

TSOP Pin and BGA Package Capacitance: Pkg types TB, TC, BB, BC

Added C_{IN3} .

Connection Diagrams

40-pin standard TSOP: Corrected pin 30 to be V_{IO} .

48-pin standard TSOP: Added superscripts to designators for pin 9, 13, 14, 15 and 47. Changed pin 13 to A21. Added two notes below illustration.

56-pin standard TSOP: Added superscripts to designators for pin 1, 2 and 12. Changed pin 56 to NC. Added three notes below illustration.

64-ball Fortified BGA: Corrected ball D8 to be V_{IO} . Added superscripts to designators for ball D8, F7, and F1. Added two notes below illustration.

63-ball Fine-pitch BGA: Added superscript to designator for Ball H7. Added one note below illustration. Added connection diagrams for S29GL064M (model R0) and S29GL032M (model R0).

Pin Description

Added V_{IO} description.

Logic Symbols

Added V_{IO} on all models except R3 and R4.

Figure 3 Write Buffer Programming Operation

Corrected the DQ locations and added callouts to notes one through three.

DC Characteristics

Corrected test conditions for I_{CC6} .

Revision A5 (April 30, 2004)**Ordering Information - S29GL032M**

Added R5 and R6 model numbers to the breakout table.

Updated the Valid Combinations for BGA packages table to reflect model numbers R5 and R6.

Ordering Information - S29GL064M

Revised R8 and R9 model numbers on the breakout table.

Updated the Valid Combinations for TSOP packages table.

Ordering Information - S29GL0128M

Added R8 and R9 model numbers to the breakout table.

Revised the Package Material Set options on the breakout table.

Updated the Valid Combinations for TSOP packages table.

Ordering Information - S29GL256M

Revised the Package Material Set options on the breakout table.

Connection Diagrams (56-Pin TSOP)

Added a callout to Note 3 for pin 15.

Device Geometry Definition table

Revised the data and description information for addresses: 28h/50h and 29h/52h.

Primary Vendor Specific Extended Query table

Revised the data and description information for addresses: 45h/8Ah (x16/x8)

Revised the data information for addresses: 4Ch/98h (x16/x8)

Erase and Programming Performance table

Revised notes 1 and 2 below the table.

Revision B0 (May 24, 2004)**Global**

Converted to full datasheet status.

Figure 18, Autoselect Codes, (High Voltage Method)

Corrected typos in description.

Added values for R5, R6, R7 description for cycle 1-3.

Added R8 and R9 to Model Number.

Revision BI (August 2, 2004)

Ordering Information-S29GL032M

Added the following temperature range: "C = Commercial (0°C to +70°C)".

Commercial temperature range options added for 90ns speeds.

Global Change

S29GL032M, S29GL064M, S29GL128M, S29GL236M ordering options pages:

Updated note 3 with the following "...TSOPs can be packed in Types 0 and 3; BGAs can be packed in Types 0, 2, or 3.

Revision B2 (September 8, 2004)

Connection Diagram - 64-ball Fortified BGA

Modified note 4.

Logic Symbol-S29GL032M (Models R3, R4)

Added models R5 and R6 to the logic symbol.

Logic Symbol-S29GL064M (Models R1, R2)

Added models R8 & R9 to the logic symbol.

S29GL032M Valid Combinations

Corrected ordering part numbers for LAA064 packages.

Physical Dimensions

Renamed the BGA-48P-M20 package as the FBG048 package.

Ordering Information

Added footnotes to indicate TSOP Pb-free leadframe plating.

Revision B3 (October 9, 2004)

General

Updated all references to Figures, Tables, and Headings to reflect page number (active link)

Updated tables 20, 21, and 22

Updated tables 24, 25, and 26

S29GL064M Valid combination

Corrected ordering part numbers for TS056 packages

S29GL032M Sector Protection/Uprotection Address Tables

Corrected table titles

S29GL064M Sector Protection/Uprotection Address Tables

Corrected table titles

Primary Vendor-Specific Extended Query

Corrected CFI data at address 48h/90h to be 0001h

DC Characteristics

Updated note 2

Figure 15, Reset Timing

Added t_{RH}

Revision B4 (January 10, 2005)

Secured Sector Flash Memory Region

Updated Secured Silicon Sector address table with addresses in x8-mode

DC Characteristics, CMOS Compatible

Corrected WP#/ACC input load current footnote

Document

Updated cross-references and format.

Valid Combination Tables

Added notes to the 128 Mb and 256 Mb combination tables.

Revision B5 (December 13, 2005)

Added Supersession text.

Corrected typos on connection diagrams and in CFI table.

Colophon

The products described in this document are designed, developed and manufactured as contemplated for general use, including without limitation, ordinary industrial use, general office use, personal use, and household use, but are not designed, developed and manufactured as contemplated (1) for any use that includes fatal risks or dangers that, unless extremely high safety is secured, could have a serious effect to the public, and could lead directly to death, personal injury, severe physical damage or other loss (i.e., nuclear reaction control in nuclear facility, aircraft flight control, air traffic control, mass transport control, medical life support system, missile launch control in weapon system), or (2) for any use where chance of failure is intolerable (i.e., submersible repeater and artificial satellite). Please note that Spanion will not be liable to you and/or any third party for any claims or damages arising in connection with above-mentioned uses of the products. Any semiconductor devices have an inherent chance of failure. You must protect against injury, damage or loss from such failures by incorporating safety design measures into your facility and equipment such as redundancy, fire protection, and prevention of over-current levels and other abnormal operating conditions. If any products described in this document represent goods or technologies subject to certain restrictions on export under the Foreign Exchange and Foreign Trade Law of Japan, the US Export Administration Regulations or the applicable laws of any other country, the prior authorization by the respective government entity be required for export of those products.

Trademarks and Notice

The contents of this document are subject to change without notice. This document may contain information on a Spanion product under development by Spanion LLC. Spanion LLC reserves the right to change or discontinue work on any product without notice. The information in this document is provided as is without warranty or guarantee of any kind as to its accuracy, completeness, operability, fitness for particular purpose, merchantability, non-infringement of third-party rights, or any other warranty, express, implied, or statutory. Spanion LLC assumes no liability for any damages of any kind arising out of the use of the information in this document.

Copyright © 2004–2005 Spanion LLC. All rights reserved.

Spanion, the Spanion logo, MirrorBit, combinations thereof, and ExpressFlash are trademarks of Spanion LLC. Other company and product names used in this publication are for identification purposes only and may be trademarks of their respective companies.