

描述 / Descriptions

表面贴装通用硅整流器，反向电压：50V~1000V，正向电流：2.0A，薄型 SOD-123FL 封装。
Surface Mount General Purpose Silicon Rectifiers, Reverse Voltage: 50 to 1000V, Forward Current: 2.0A, SOD-123FL thin package.

特征 / Features

玻璃钝化芯片，无铅符合欧盟 RoHS 指令 2011/65/EU，适用于表面贴装。无卤产品。
Glass Passivated Chip Junction, Lead free in comply with EU RoHS 2011/65/EU directives, For surface mounted applications. Halogen free product.

用途 / Applications

一般用途。
General purpose.

内部等效电路 / Equivalent Circuit



引脚排列 / Pinning

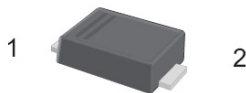

PIN	DESCRIPTION
1	Cathode
2	Anode

The recommended mounting pad size

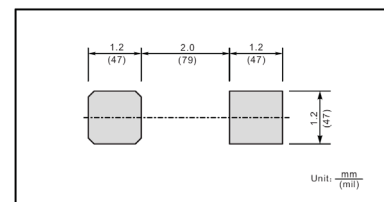

印章代码 / Marking

见印章说明。See Marking Instructions.

极限参数 / Absolute Maximum Ratings(Ta=25°C)

参数 Parameter	符号 Symbol	数值 Rating							单位 Unit
		S2AW	S2BW	S2DW	S2GW	S2JW	S2KW	S2MW	
Maximum Repetitive Peak Reverse Voltage	V_{RRM}	50	100	200	400	600	800	1000	V
Maximum RMS voltage	V_{RMS}	35	70	140	280	420	560	700	V
Maximum DC Blocking Voltage	V_{DC}	50	100	200	400	600	800	1000	V
Maximum Average Forward Rectified Current at Ta= 65°C	$I_{F(AV)}$	2.0							A
Peak Forward Surge Current 8.3 ms Single Half Sine Wave Superimposed on Rated Load (JEDEC Method)	I_{FSM}	50							A
Typical Junction Capacitance at VR=4V, f=1MHz	C_j	30							pF
Typical Thermal Resistance ¹⁾	$R_{\theta JA}$	90							°C/W
Operating and Storage Temperature Range	T_j, T_{stg}	-55~+150							°C

Note:

1) P.C.B. mounted with 0.2 X 0.2" (5 X 5 mm) copper pad areas.

电性能参数 / Electrical Characteristics(Ta=25°C)

参数 Parameter	符号 Symbol	测试条件 Test Conditions	数值 Rating							单位 Unit
			S2AW	S2BW	S2DW	S2GW	S2JW	S2KW	S2MW	
Maximum Forward Voltage	V_F	$I_F=2.0A$	1.1							V
Maximum DC Reverse Current at Maximum DC Blocking Voltage	I_R	$T_a=25^\circ C$	5.0							μA
		$T_a=125^\circ C$	50							μA

电参数曲线图 / Electrical Characteristic Curve

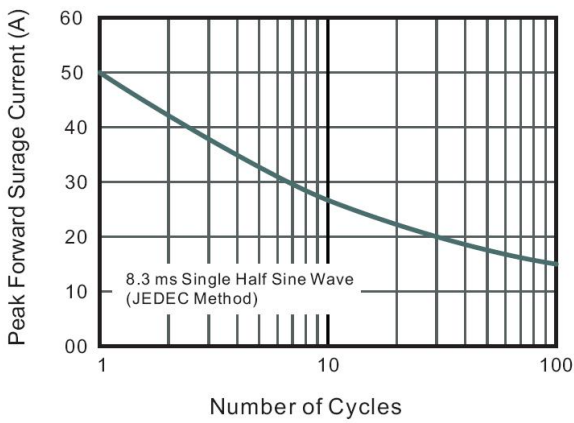
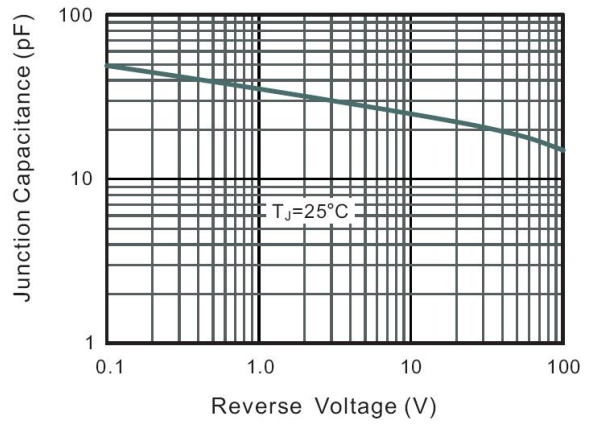
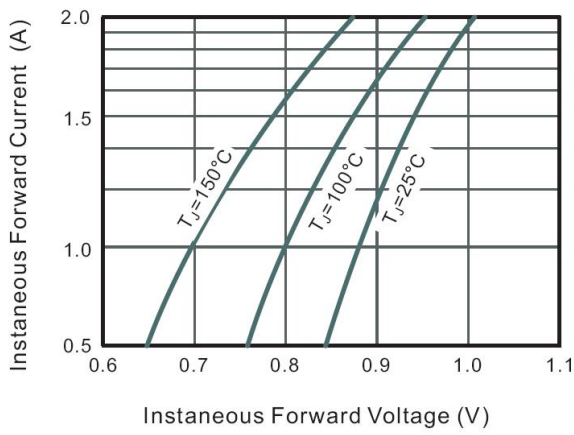
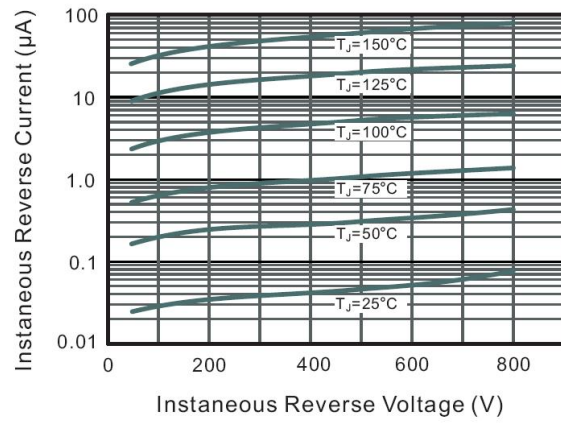
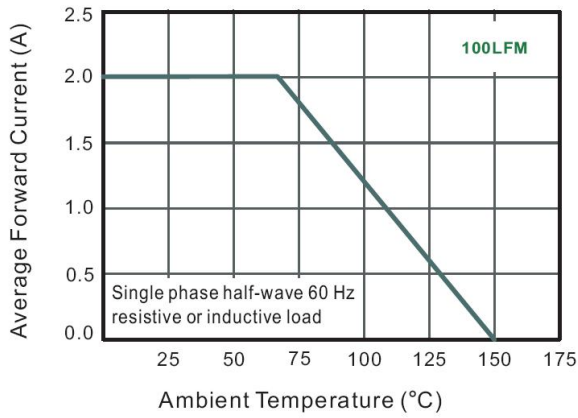

外形尺寸图 / Package Dimensions

SOD-123FL

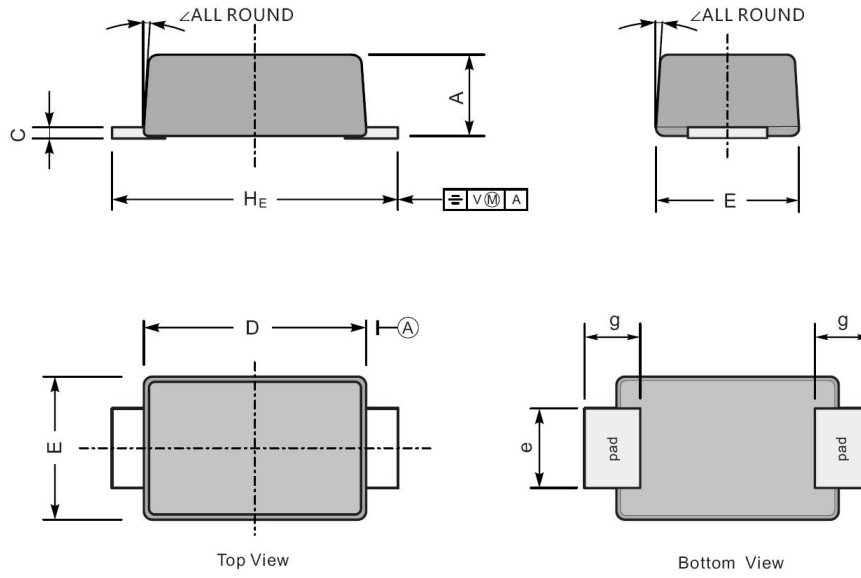

UNIT		A	C	D	E	e	g	H_E	\angle
mm	max	1.1	0.20	2.9	1.9	1.1	0.9	3.8	7°
	min	0.9	0.12	2.6	1.7	0.8	0.7	3.5	
mil	max	43	7.9	114	75	43	35	150	
	min	35	4.7	102	67	31	28	138	

Marking

Type number	Marking code
S2AW	2A1
S2BW	2A2
S2DW	2A3
S2GW	2A4
S2JW	2A5
S2KW	2A6
S2MW	2A7

回流焊温度曲线图(无铅) / Temperature Profile for IR Reflow Soldering(Pb-Free)



说明：

- 1、预热温度 25 ~ 150°C，时间 60 ~ 90sec;
- 2、峰值温度 245±5°C，时间持续为 5±0.5sec;
- 3、焊接制程冷却速度为 2 ~ 10°C/sec.

Note:

- 1.Preheating:25~150°C, Time:60~90sec.
- 2.Peak Temp.:245±5°C, Duration:5±0.5sec.
3. Cooling Speed: 2~10°C/sec.

耐焊接热试验条件 / Resistance to Soldering Heat Test Conditions

温度：260±5°C

时间：10±1 sec.

Temp.:260±5°C

Time:10±1 sec

包装规格 / Packaging SPEC.

卷盘包装 / REEL

Package Type 封装形式	Units 包装数量					Dimension 包装尺寸 (unit: mm ³)		
	Units/Reel 只/卷盘	Reels/Inner Box 卷盘/盒	Units/Inner Box 只/盒	Inner Boxes/Outer Box 盒/箱	Units/Outer Box 只/箱	Reel	Inner Box 盒	Outer Box 箱
SOD-123FL	3000	8	24000	5	120000	7" ×11	185X180X105	550X210X220

使用说明 / Notices