**SSOPH-28N**

With Heat-sink

**ORDERING INFORMATION**

Product	Marking	Package
S3056	S3056	SSOPH-28N

**▲ Marking Detail Information**

① Device Code

② Year &amp; Week Code

**Description**

The S3056 contains 4 channels voltage-type BTL drivers for actuators [ focus, tracking ] and sled, spindle motor drivers and it also contains 1 channel of bi-directional tray motor driver.

Furthermore it embraces 2 independent precision voltage comparators for external application circuits even amplifying internal drivers.

It supports various applications with pb free and heat-sink package.

**Application**

- ◆ CD-Player
- ◆ CD-ROM
- ◆ DVD-Player

**Features and Benefits**

- ◆ 1 Channel is bi-directional DC motor driver for tray.
- ◆ 4 Channels are voltage-type BTL drivers for actuators[ focus, tracking ] and sled, spindle motors.
- ◆ Built in general-purpose voltage open collector output 2 comparators.
- ◆ Separating power of Vcc1 and Vcc2 is to improve power efficiency.
- ◆ Built in Level shift circuit.
- ◆ Built in Thermal shut down circuit.
- ◆ Built in Mute mode.
- ◆ **Dual Actuator drivers**  
A general purpose input OP Provides differential input for signal addition.  
The output structure is two power OPAMPS in bridge configuration.
- ◆ **Sled motor driver**  
A general purpose input OP provides differential input for signal addition.  
The output structure is one power OPAMP in bridge configuration.
- ◆ **Spindle driver**  
Single input linear BTL driver. The output structure are two power OPAMPS in bridge configuration.
- ◆ **Tray Bi-directional driver**  
The DC motor driver supports forward/reverse control for tray motor.

◆ Internal Block Diagram & Pin Assignment

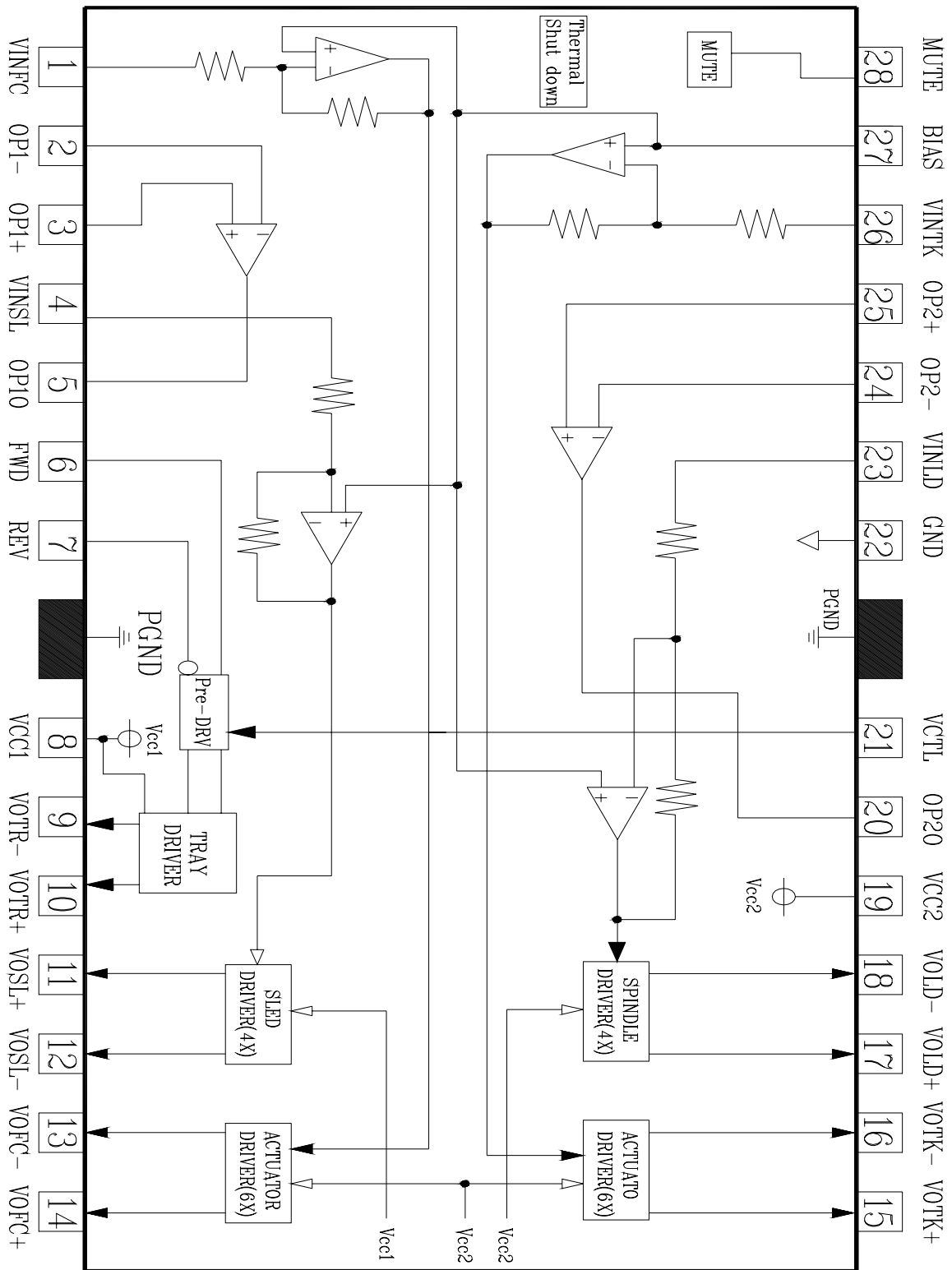

◆ Pin Description

NO	SYMBOL	I/O	DESCRIPTION
1	VINFC	I	Input for focus driver
2	OP1-	I	Comparator 1 input [-]
3	OP1+	I	Comparator 1 input [+]
4	VINSL	I	Input for sled driver
5	OP1O	O	Comparator 1 output
6	FWD	I	Tray driver input signal for forward direction
7	REV	I	Tray driver input signal for reverse direction
8	V <sub>CC1</sub>	PWR	V <sub>CC</sub> for pre-drive block and power block of sled & tray
9	VOTR-	O	Tray driver output (-)
10	VOTR+	O	Tray driver output (+)
11	VOSL+	O	Sled driver output (+)
12	VOSL-	O	Sled driver output (-)
13	VOFC-	O	Focus driver output (-)
14	VOFC+	O	Focus driver output (+)
15	VOTK+	O	Tracking driver output (+)
16	VOTK-	O	Tracking driver output (-)
17	VOLD+	O	Spindle driver output (+)
18	VOLD-	O	Spindle driver output (-)
19	V <sub>CC2</sub>	PWR	V <sub>CC</sub> for power block of focus, tracking and spindle
20	OP2O	O	Comparator 2 output
21	VCTL	-	Speed control input of tray driver
22	GND	-	Ground
23	VINLD	I	Input for spindle driver
24	OP2-	I	Comparator 2 input [-]
25	OP2+	I	Comparator 2 input [+]
26	VINTK	I	Input for tracking driver
27	BIAS	I	Input for reference voltage
28	MUTE	I	Input for mute control

Symbol of + and – [ output of drives ] means polarity to input pin.

For example : if voltage level of pin1 is high, pin14 is high

◆ Absolute Maximum Ratings (  $T_a = 25^\circ\text{C}$  )

Parameter	Symbol	Limits	Unit
Supply Voltage	$V_{CC1}/V_{CC2}$	13.5	V
Power Dissipation	$P_d$	1.7	W
Operate Temperature Range	$T_{opr}$	-35 ~ +85	$^\circ\text{C}$
Storage Temperature Range	$T_{stg}$	-55 ~ +150	$^\circ\text{C}$

[  $P_d$  ] When mounted on a 70mm×70mm×1.6mm glass epoxy board.

Reduced by 13.6mW for each increase in  $T_a$  of  $1^\circ\text{C}$

[  $T_{stg}$  ] Should not exceed  $P_d$  or SOA and  $T_j=150^\circ\text{C}$  values

◆ Guaranteed Operating Conditions (  $T_a = 25^\circ\text{C}$  )

Parameter	Symbol	Limits	Unit
Power Supply Voltage	$V_{CC1}$	4.3 ~ 13.2	V
	$V_{CC2}$	4.3 ~ $V_{CC1}$	V

◆ Power Dissipation Curve [  $P_d$  ]

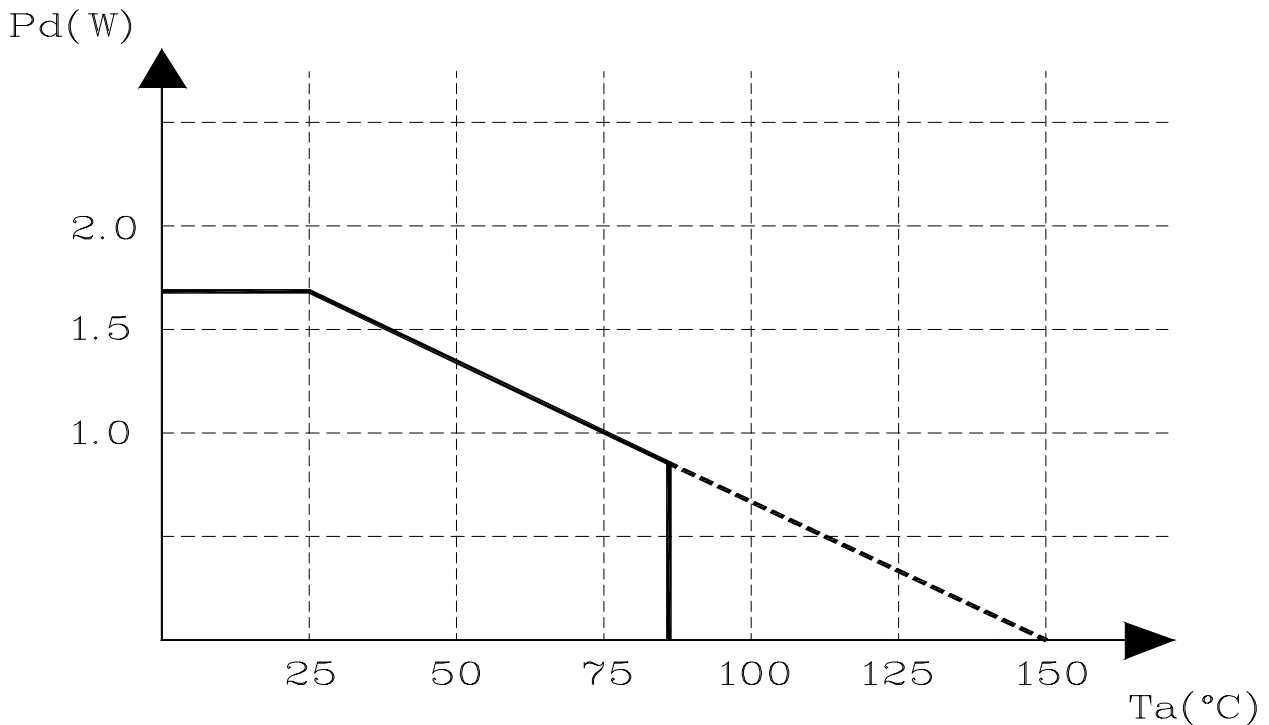

◆ 70mm×70mm×1.6mm glass epoxy board .

◆ De-rating is done at 13.6mW/ $^\circ\text{C}$  for operating above  $T_a=25^\circ\text{C}$

## ◆ Electrical characteristics

( Unless otherwise specified Ta=25°C, Vcc1=12V, Vcc2=5V, BIAS=2.5V, RL=8Ω/12Ω/20Ω/45Ω)

NO	Characteristics	Symbol	Condition	Specification			Unit
				MIN.	TYP.	MAX.	
1	Quiescent current	Iqc		-	30	-	mA
2	Voltage for Mute on	Vston		0	-	0.5	V
3	Voltage for Mute off	Vstoffs		2	-	5	V
<b>&lt; Actuator Driver: Focus, Tracking &gt;</b>							
4	Output Offset Voltage	Voo		-50	-	50	mV
5	Maximum output Voltage	Vom	@12Ω Load	3.6	4	-	V
6	Voltage Gain	Gv	VIN=BIAS+0.2Vpp ac @1khz	21.5	23.5	25.5	dB
<b>&lt; Sled Motor Driver &gt;</b>							
7	Output Offset Voltage	Voosl		-100	-	100	mV
8	Maximum output Voltage	Vomsl	@20Ω Load	7.5	9.0	-	V
9	Voltage Gain	Gvsl	VIN=BIAS+0.2Vpp ac @1khz	18.0	20.0	22.0	dB
<b>&lt; Spindle Motor driver &gt;</b>							
10	Output Offset Voltage	Voold		-50	-	50	mV
11	Maximum output Voltage	Vomld	@8Ω Load	-	3.5	-	V
12	Voltage Gain	Gvld	VIN=BIAS+0.2Vpp ac @1khz	13.5	15.5	17.5	dB
<b>&lt; Tray Motor driver &gt;</b>							
13	Output saturation Voltage1	Vsat1	Upper + Lower saturation IL=200mA	0.7	1.1	1.5	V
14	Output saturation voltage between F&R	ΔVsat1	Output saturation voltage1 between FWD and REV	-	-	0.1	V
15	Output saturation Voltage2	Vsat2	Upper + Lower saturation IL=200mA	1	1.55	2.2	V
16	Output adjustable gain on "H" side voltage	VvtrH	VCTL=2V	7.4	9.2	11	dB
<b>&lt; Tray Motor driver input logic &gt;</b>							
17	High level input voltage	VIH		1.5	-	Vcc	V
18	Low level input voltage	VIL		-0.3	-	0.5	V
19	High level input current	IIH	VFWD=VREV=5V	-	180.0	270.0	uA
<b>&lt; Comparator &gt;</b>							
20	High level output voltage	VOH	Vcc1=Vcom=5V OPN=2V, OPP=3V, RL=4.7K	-	-	Vcc	V
21	Low level output voltage	VOL	Vcc1=Vcom=5V OPN=2V, OPP=1V, RL=4.7K	-	-	0.5	mV
22	Output sink current	Isink1	Vcc1=Vcom=5V OPN=2V, OPP=1V, RL=4.7K	0.80	1.00	-	mA
		Isink2	Vcc1=Vcom=5V OPN=2V, OPP=1V	25.00	35.00	-	mA

## Application Information

### 1. Thermal Shut Down Circuit

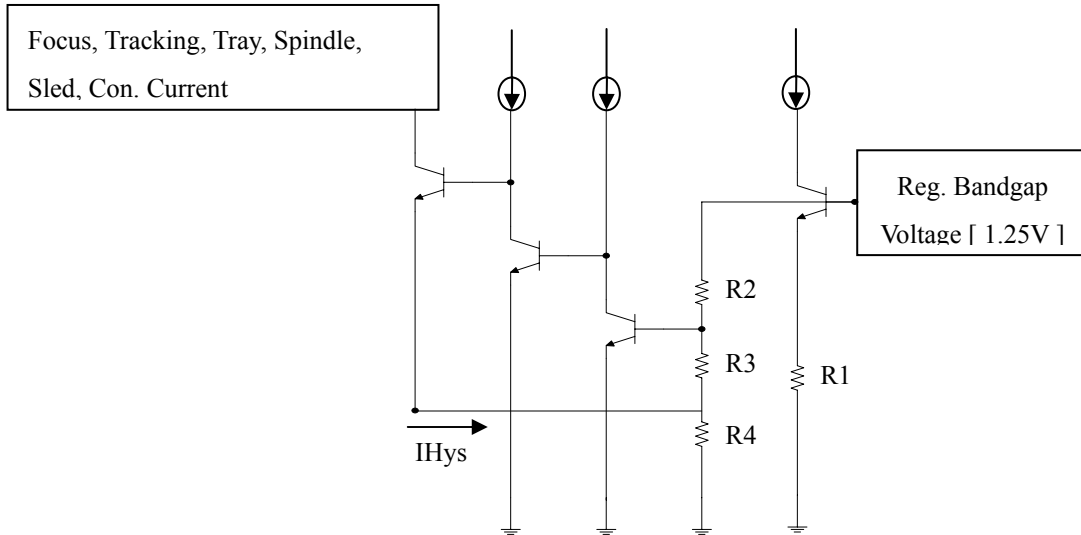

The built-in thermal shutdown circuit mutes the output current when the chip temperature reaches 175°C (typ.). The hysteresis is set to 25°C (typ.) by IHys, so the circuit will start up again when the chip temperature falling to 150°C (typ.)

### 2. Comparator Circuit

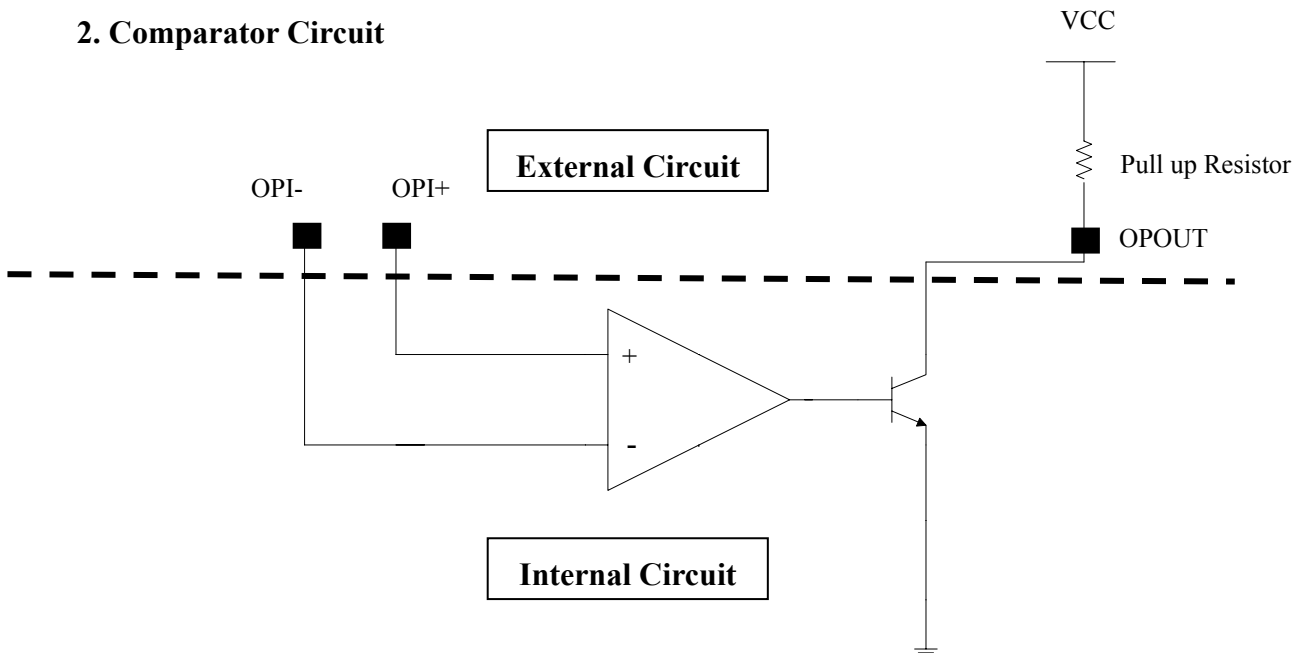

- It can be used general Comparators or OP-AMPS
- It needs to attach an external circuit as user's application circuits.

### 3. Bias & Mute Circuit

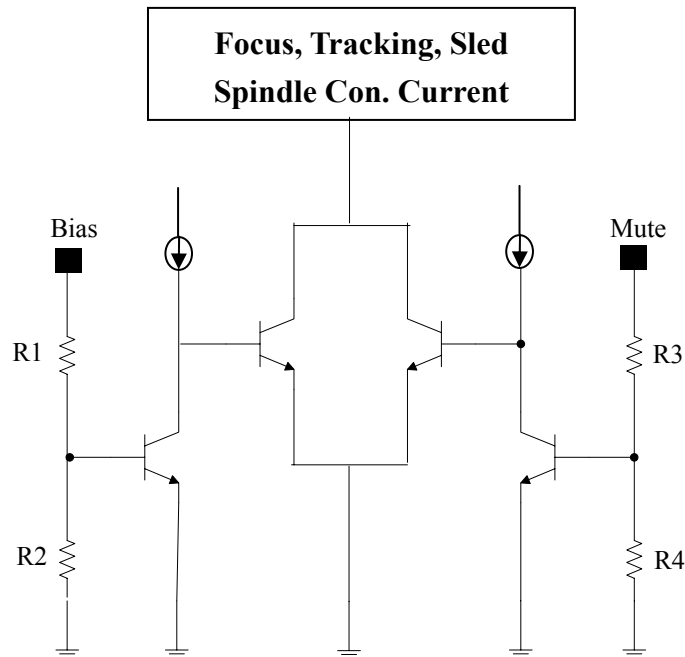

Bias pin (pin 27) should be pulled up to more than 1.2V. In case the bias pin's voltage is pulled down below 1.2V (typ.), the output current is muted, also Mute pin is same as Bias pin.

[Except Tray, Regulator, Comparator, those are only controlled by Vcc1. ]

#### 4. BTL Driver Circuits [Focus, Tracking, Sled, Spindle]

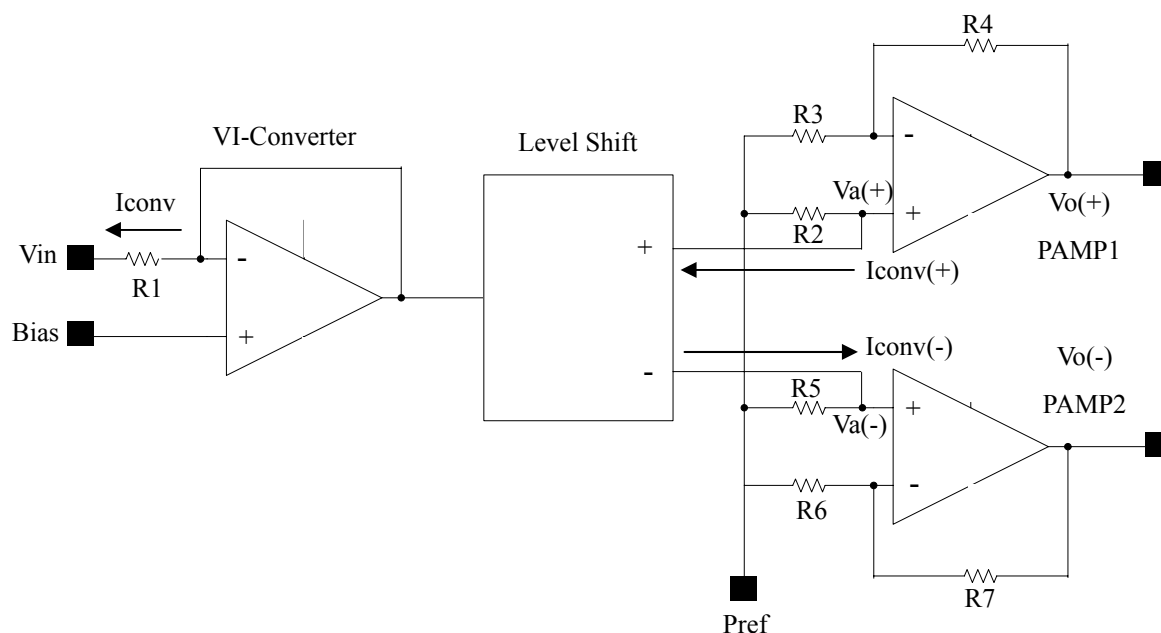

BTL Driver Circuits are composed of VI-Converter, Level Shifter and Output power AMP.

VI-Converter converts voltage of  $V_{in}$  into current [Iconv]

$$I_{conv} = (V_{in} - \text{Bias}) / R1 [10K\Omega]$$

#### [ Closed loop Voltage Gain Calculation ]

$$V_{a(+)} = (R2 \times I_{conv}) + \text{Pref}$$

$$V_{a(-)} = (-R5 \times I_{conv}) + \text{Pref}$$

$$V_{o(+)} = V_{a(+)} \times (1 + R4/R3)$$

$$V_{o(-)} = V_{a(-)} \times (1 + R7/R6)$$

$$[* R2 = R5, R3 = R6, R4 = R7 *]$$

#### Focus, Tracking closed loop Voltage Gain [ $R2 = 25K\Omega$ , $R3 = 10K\Omega$ , $R4 = 20K\Omega$ ]

$$\text{Gain} = 20 \log \left[ \frac{V_{o(+)} - V_{o(-)}}{V_{in} - \text{Bias}} \right]$$

$$= 20 \log \left[ \frac{V_{a(+)} \times (1 + R3/R4) - V_{a(-)} \times (1 + R6/R7)}{V_{in} - \text{Bias}} \right]$$

$$= 20 \log \left[ \frac{\{(R2 \times I_{conv}) + \text{Pref}\} \times (1 + R4/R3) - \{(-R5 \times I_{conv}) + \text{Pref}\} \times (1 + R7/R6)}{V_{in} - \text{Bias}} \right]$$

$$= 20 \log [2 \times (25K/10K) \times \{1 + (20K/10K)\}]$$

$$= 23.5 \text{ [dB]}$$

#### Sled closed loop Voltage Gain [ $R2 = 25K\Omega$ , $R3 = 10K\Omega$ , $R4 = 10K\Omega$ ]

$$\text{Gain} = 20 \log [2 \times (25K/10K) \times \{1 + (10K/10K)\}]$$

$$= 20 \text{ [dB]}$$

#### Spindle closed loop Voltage Gain [ $R2 = 15K\Omega$ , $R3 = 10K\Omega$ , $R4 = 10K\Omega$ ]

$$\text{Gain} = 20 \log [2 \times (25K/10K) \times \{1 + (10K/10K)\}]$$

$$= 15.5 \text{ [dB]}$$



5. Tray driver logic input

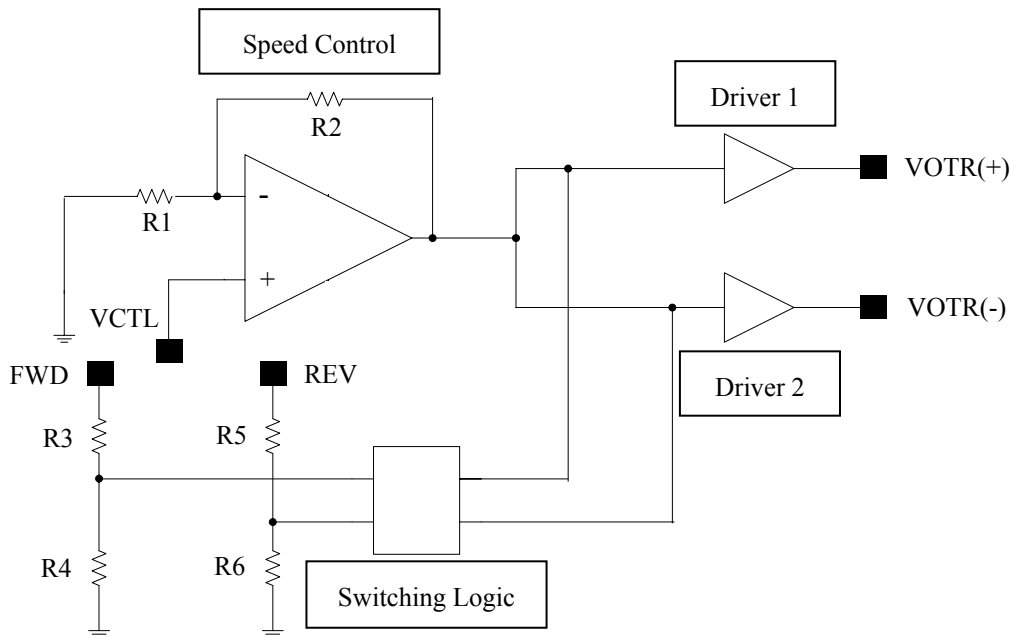

FWD [pin6]	REV [pin7]	VOTR+ [pin10]	VOTR- [pin9]	FUNCTION
L	L	OPEN	OPEN	Open mode
L	H	L	H	Reverse mode
H	L	H	L	Forward mode
H	H	L	L	Brake mode

Input circuit of pin6 [FWD] and pin7 [REV] is designed to avoid simultaneous activation of upper and lower output power TR. however, in order to improve reliability, apply motor forward/reverse input once through open mode. We recommend that the time period of open state is longer than 10msec.

“H” side output voltage on output voltage [VOL+, VOL-] varies depending on output control terminal for tray. [pin21]“H” side output voltage is set three times (9.2dB typ.) VTCL [pin21], and “L” side output voltage is equal to output saturation voltage.

### Characteristic Diagrams

**Fig. 1  $V_{CC} - I_{QC}$**

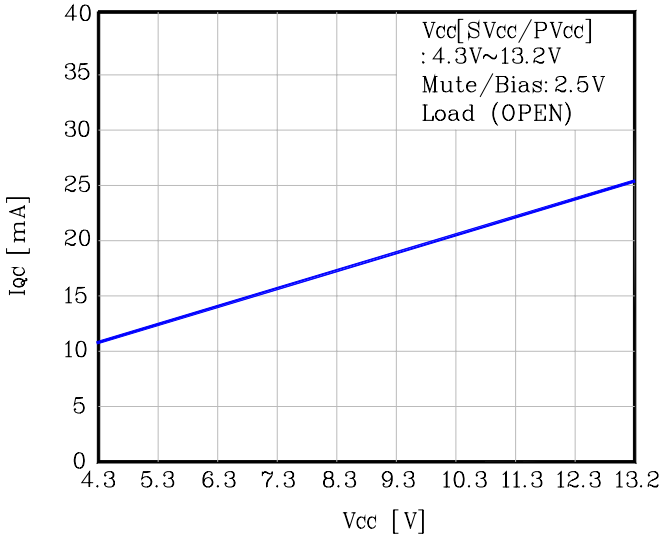

**Fig. 2 Temperature -  $I_{QC}$**

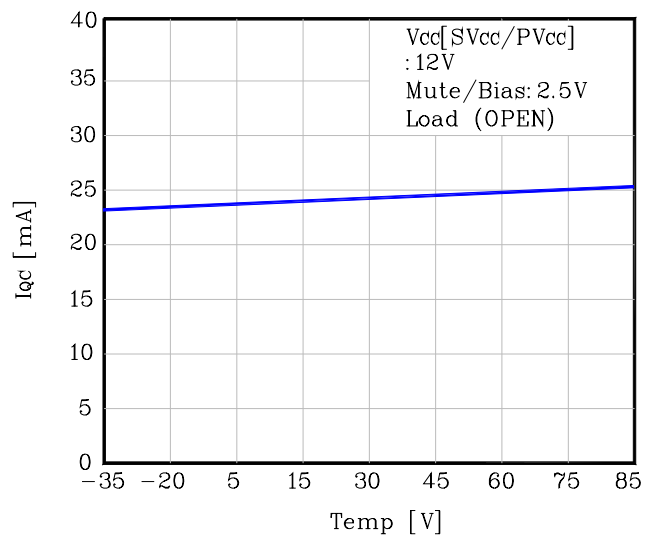

**Fig. 3  $V_{OM} - V_{CC}$**

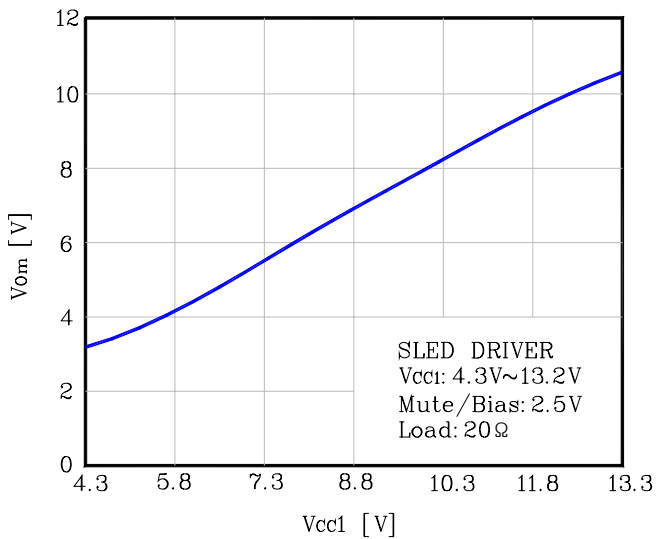

**Fig.4  $V_{OM} - V_{CC}$**

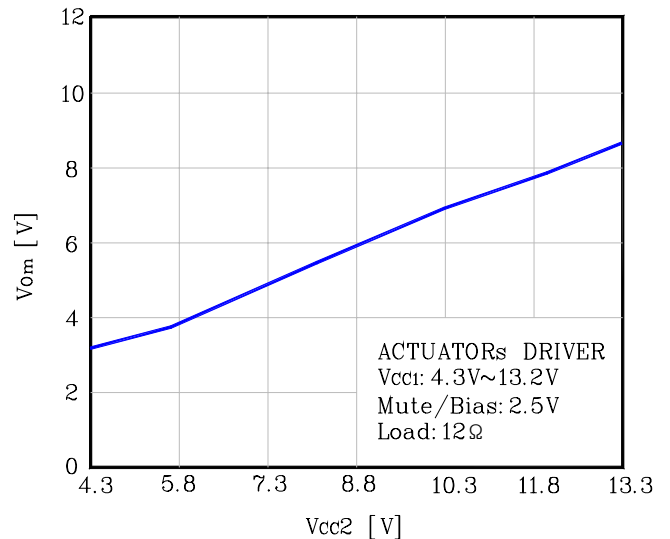

**Fig. 5  $V_{OM} - V_{CC}$**

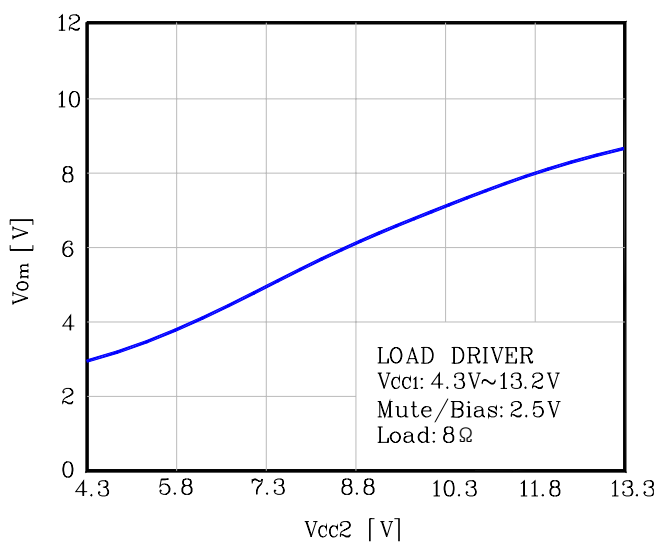

**Fig.6 OP  $V_{IN} - OP V_O$**

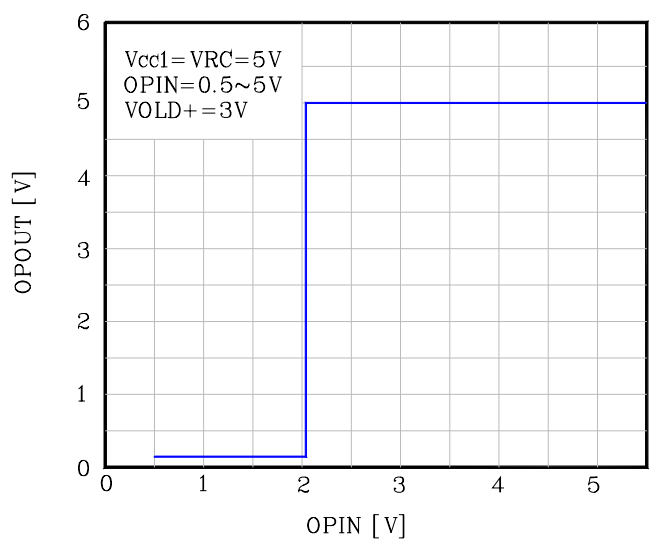

◆ Testing Circuit

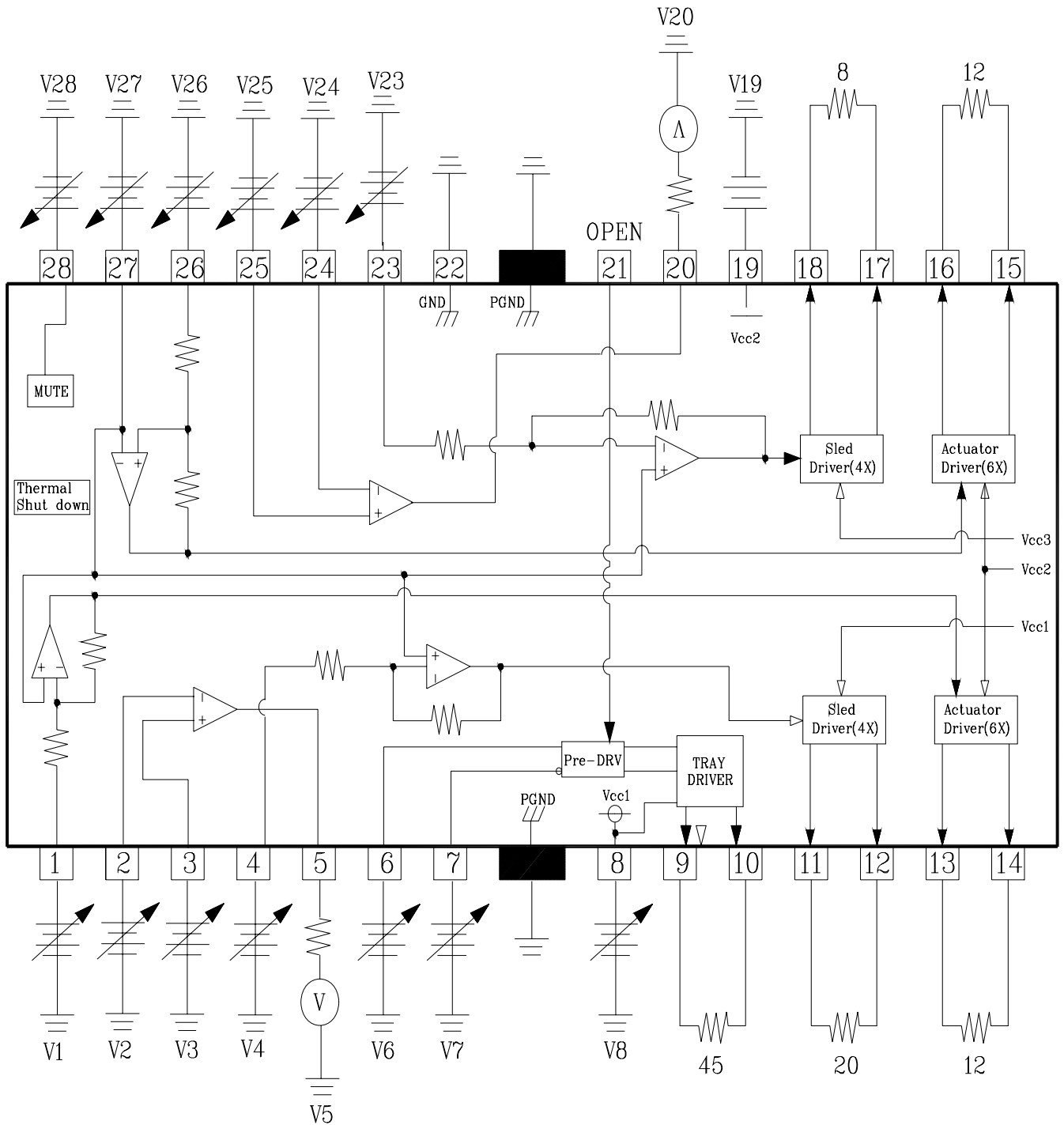

◆ Outline Dimension

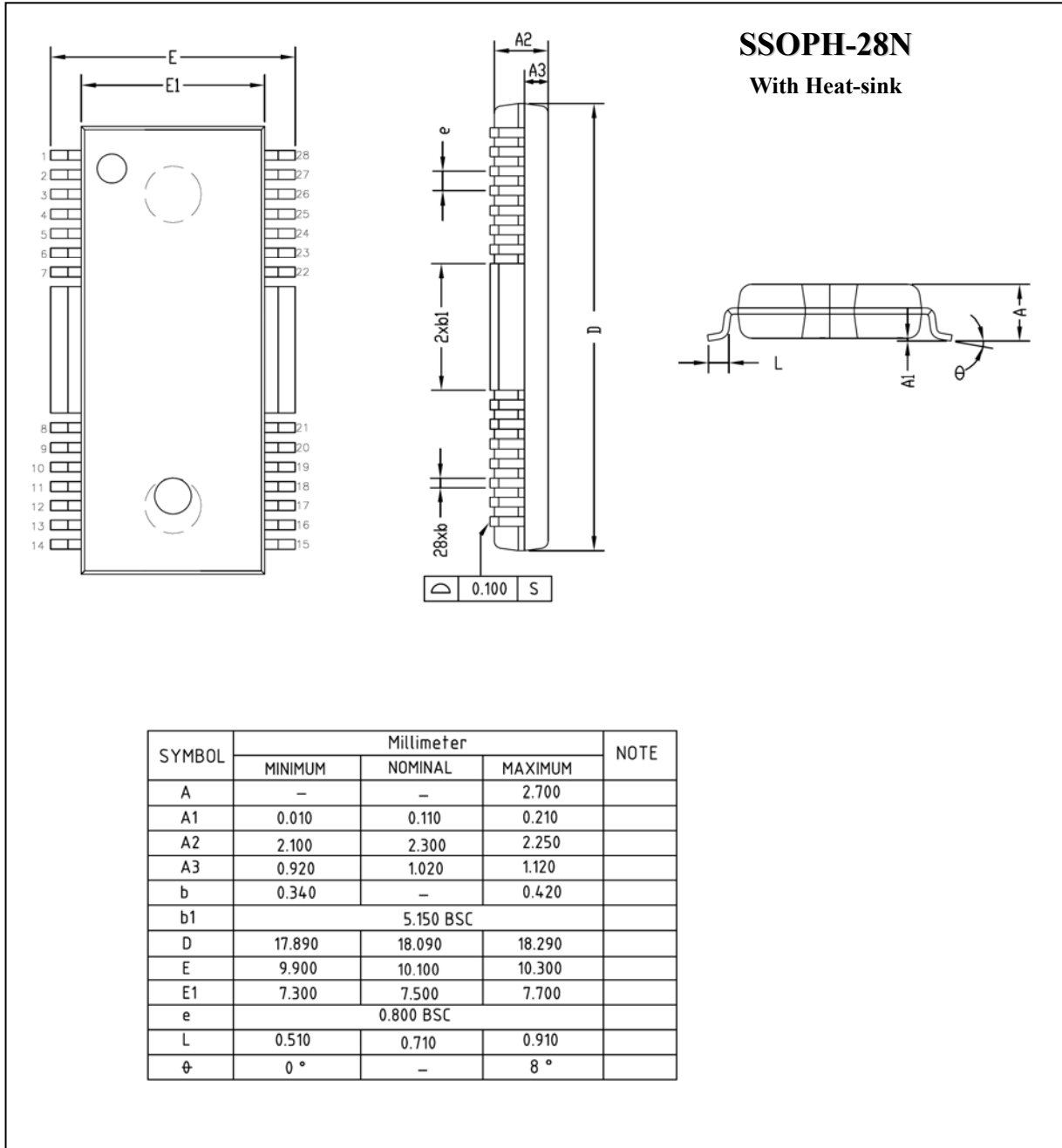

**The AUK Corp. products are intended for the use as components in general electronic equipment (Office and communication equipment, measuring equipment, home appliance, etc.).**

**Please make sure that you consult with us before you use these AUK Corp. products in equipments which require high quality and / or reliability, and in equipments which could have major impact to the welfare of human life(atomic energy control, airplane, spaceship, transportation, combustion control, all types of safety device, etc.). AUK Corp. cannot accept liability to any damage which may occur in case these AUK Corp. products were used in the mentioned equipments without prior consultation with AUK Corp..**

**Specifications mentioned in this publication are subject to change without notice.**