

Descriptions

The S3882 is fixed PWM controller for Off-line and DC-DC converter applications. The internal circuits include UVLO, low start up current circuit, temperature compensated reference, high gain error amplifier, current sensing comparator, and high current totempole output for driving a power MOSFET.

Also S3882 provide low start up current below 0.3mA and short shutdown delay Time typical 100nsec.

S3882 have UVLO threshold of 16V(on) and 10V(off).

Features

- Low start up current < 0.3mA
- Operating range up to 500KHz
- Cycle by cycle current limiting
- Under Voltage Lock Out with hysteresis
- Short shutdown delay time ; typical 100nsec
- High current totempole output
- Output swing limiting : 22V

Ordering Information

Type NO.	Marking	Package Code
S3882	S3882	SOP-8

Outline Dimensions

unit : mm

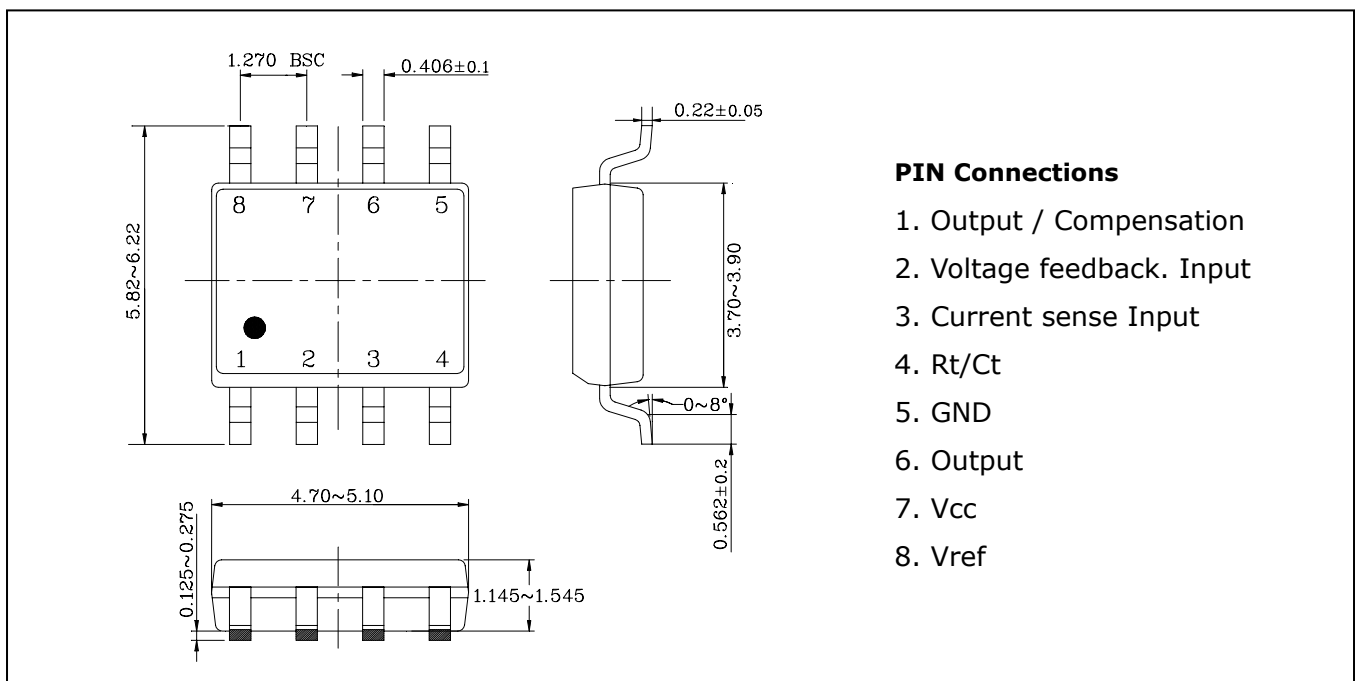

Absolute Maximum Ratings

Ta=25°C

Characteristic	Symbol	Ratings	Unit
Supply Voltage	V _{CC}	28	V
Output Current	I _O	1	A
Analog Inputs	V _{i(ana)}	-0.3 to 6.3	V
Error Amp. Output Sink current	I _{sink(EA)}	10	mA
Power Dissipation	P _d	1	W

Electrical Characteristics(V_{CC}=15V, R_t=10Kohm, C_t=3.3nF, Ta=0°C to 70°C, Unless otherwise specified)

Characteristic	Symbol	Test Condition	Min.	Typ.	Max.	Unit
1. Reference Section						
Output Voltage	V _{ref}	T _j =25°C, I _O =1mA	4.91	5.00	5.09	V
Line Regulation	Δ V _{ref}	12V ≤ V _{CC} ≤ 25V	-	6	20	mV
Load Regulation	Δ V _{ref}	1mA ≤ I _O ≤ 20mA	-	6	25	mV
Output Short Current	I _{sc}	Ta=25°C	-180	-100	-	mA
2. Oscillator Section						
Initial Accuracy	f _{OSC}	T _j =25°C	47	52	57	KHz
Voltage Stability	Δf / ΔV	12V ≤ V _{CC} ≤ 25V	-	0.2	1.0	%
Oscillator Voltage	V _{OSC}	V _{pin4} , peak to peak	1.4	1.7	1.8	V
Discharge Current	I _{discharge}	T _j =25°C, Pin4=2V	7.8	8.3	8.8	mA
3. Error Amp Section						
Input Voltage	V ₂	V _{PIN1} =2.5V	2.42	2.50	2.58	V
Input Bias Current	I _b	-	-2.0	-0.3	-	μA
Open Loop Voltage Gain	A _{VO1}	2V ≤ V _O ≤ 4V	65	90	-	dB
Unity Gain Bandwidth	GBW	T _j =25°C	0.7	1	-	MHz
PSRR	PSRR1	V _{CC} =12V to 25V	60	70	-	dB
Output Sink Current	I _{SINK}	V _{PIN2} =2.7V, V _{PIN1} =1.1V	2	6	-	mA
Output Source Current	I _{SOURCE}	V _{PIN2} =2.3V, V _{PIN1} =5V	-	-0.8	-0.5	mA
Output High Voltage	V _{OH}	V _{pin2} =2.3V, R ₁ =15 kΩ to GN	5	6	-	V
Output Low Voltage	V _{OL}	V _{PIN2} =2.3V, R ₁ =15 kΩ to PIN8	-	0.8	1.1	V
4. Current Sense Section						
Gain	G _V	-	2.85	3.0	3.15	V/V
Maximum Input Signal	V _{i(MaX)}	V _{PIN 1} =5V	0.9	1.0	1.1	V
PSRR	PSRR2	12V ≤ V _{CC} ≤ 25V	-	70	-	dB
Input Bias Current	I _{bias}	-	-10	-2	-	μA
Delay to Output	T _d	V _{PIN 3} =0V to 2V	-	100	200	nS

Electrical Characteristics(continued)

(V_{cc}=15V, R_t=10Kohm, C_t=3.3nF, T_a=0°C to 70°C, Unless otherwise specified)

Characteristic	Symbol	Test Condition	Min.	Typ.	Max.	Unit
5. Output Section						
Output Low Level1	V _{OL1}	I _{sink} =20mA	-	0.1	0.4	V
Output Low Level2	V _{OL2}	I _{sink} =200mA	-	1.5	2.0	V
Output High Level1	V _{OH1}	I _{source} =20mA	13.0	13.5	-	V
Output High Level2	V _{OH2}	I _{source} =200mA	12.0	13.5	-	V
Rise Time	t _r	T _j =25°C, C ₁ =1nF	-	40	100	nS
Fall Time	t _f	T _j =25°C, C ₁ =1nF	-	40	100	nS
Out Volt. Swing Limit	V _{olim}	V _{cc} =27V, C ₁ =1nF	-	22	-	V
6. Under Voltage Lockout Section						
Start Threshold	V _{th}	-	15	16	17	V
Min. Operating Voltage	V _{tL}	After turn on	9	10	11	V
7.PWM Section						
Maximum Duty Cycle	D _{max}	-	94	96	100	%
Minimum Duty Cycle	D _{min}	-	-	-	0	%
8.Total Standby Section						
Start-Up Current	I _{st}	-	-	0.2	0.4	mA
Operating Supply Current	I _{CC}	V _{pin2} =V _{pin3} =0V	-	11	17	mA
V _{CC} Zener Voltage	V _Z	I _{CC} =25mA	-	29	-	V

NOTE: Adjust V_{cc} above the the start threshold before setting at 15V

Block Diagram

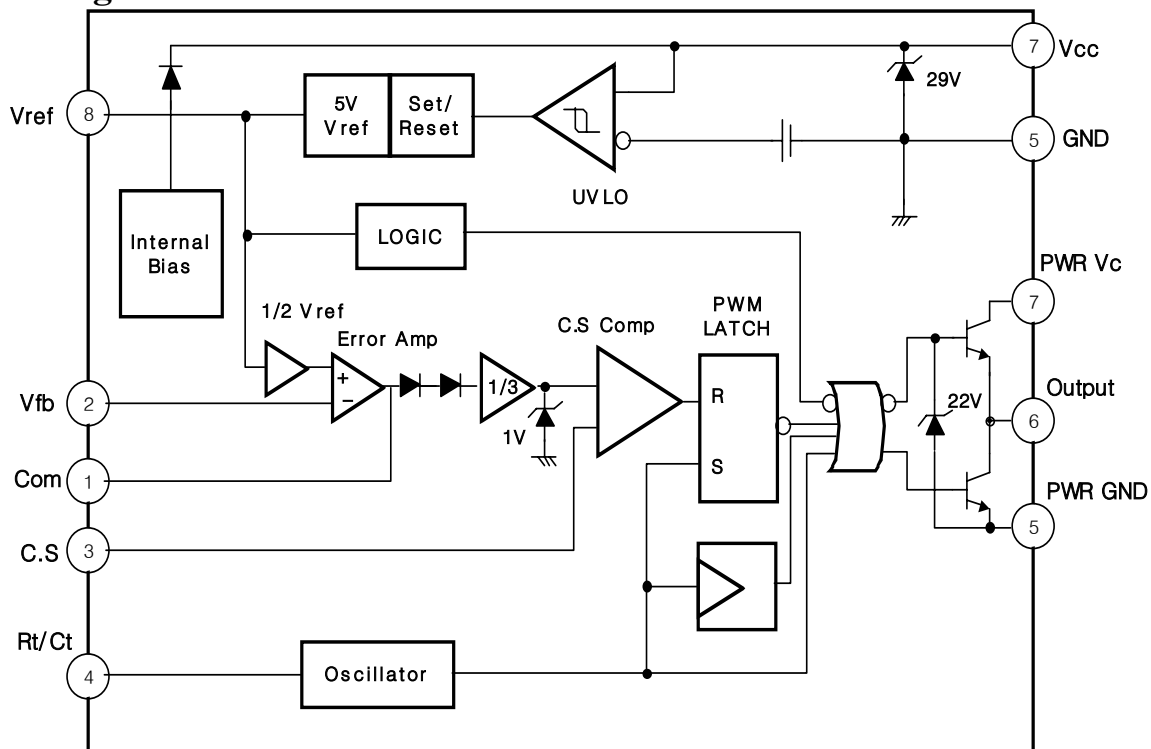

Information in Using IC

1. Under voltage Lockout

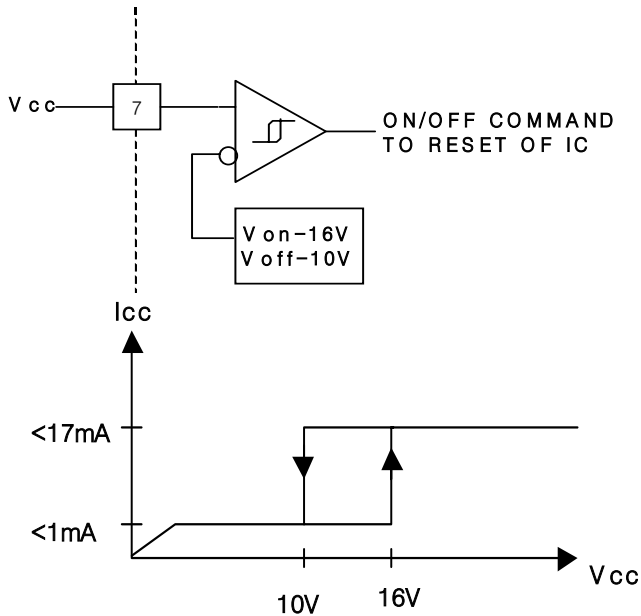

To prevent erratic output behavior which activating the power switch with extraneous leakage currents, during under voltage lockout. Output(pin6) should be shunted to ground with a bleeder resistor.

The Vcc comparator upper and lower threshold are 16V/10V. The large hysteresis and low start up currents makes it ideally suited in off-line converter application where efficient bootstrap start-up techniques are required.

2. Oscillator Waveforms and Maximum Duty Cycle

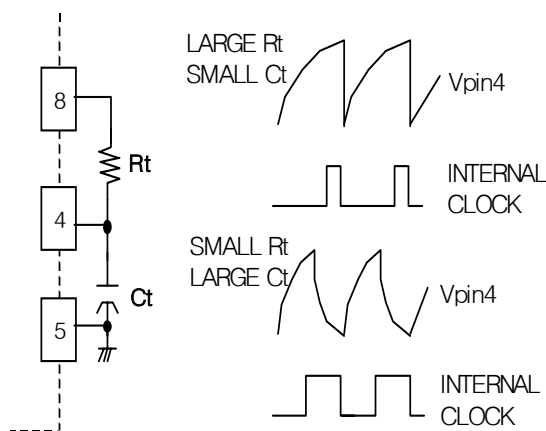

The oscillator frequency is programmed by the values selected for the timing components R_t and C_t . C_t is charged from 5V, V_{ref} , through resistor R_t to approximately 2.8V and discharged to 1.2V by an internal current sink.

During the discharge of C_t , the oscillator generates an internal blanking pulse and the center input NOR gate high. This makes output to be in a low state and control the amount of output dead time.

3. Error AMP Configuration

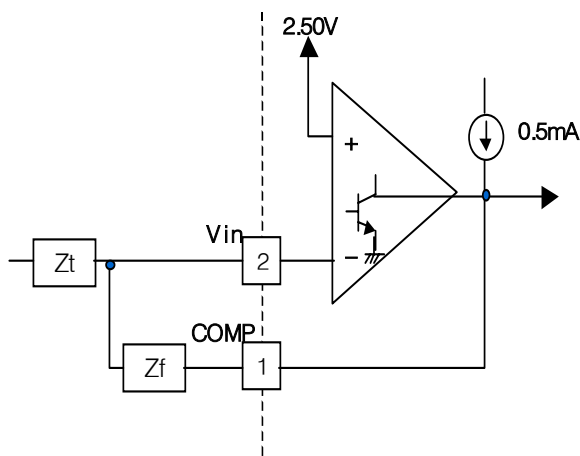

Error amp output(Pin1) is provided for external loop compensation and error amp can source or sink up to 0.5mA. The non-inverting input is internally biased at 2.5V and is not pinned out. The converter output voltage is typically divided down and monitored by the inverting input(pin2).

4. Current Sense Circuit

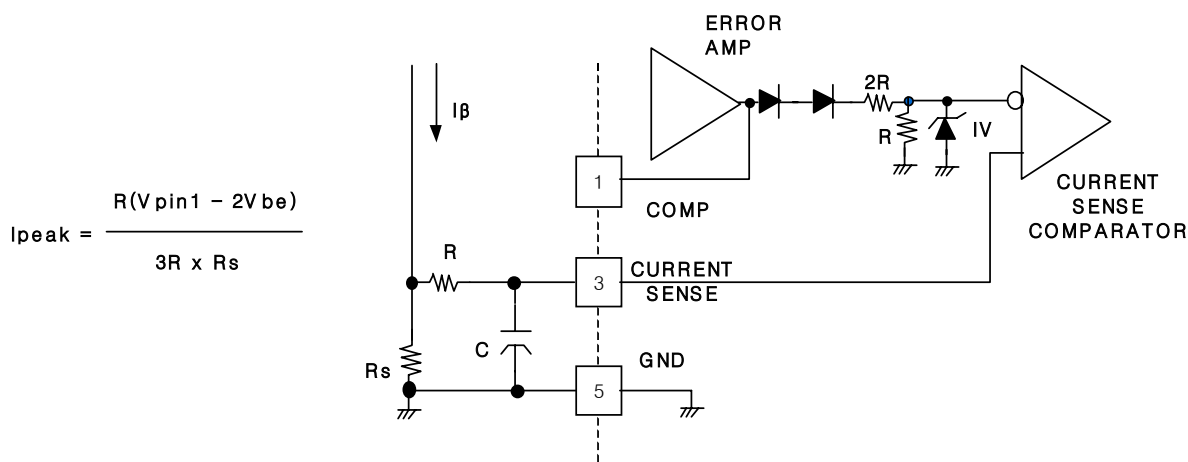

A normal operating conditions occurs when the power supply output is overloaded or if output voltage to 1.0V. Therefore the maximum peak switch current is $I_{pk(max)} = 1.0V/R_s$, and under the normal operating conditions the peak inductor current controlled by the voltage at pin1.

5. Shutdown Techniques

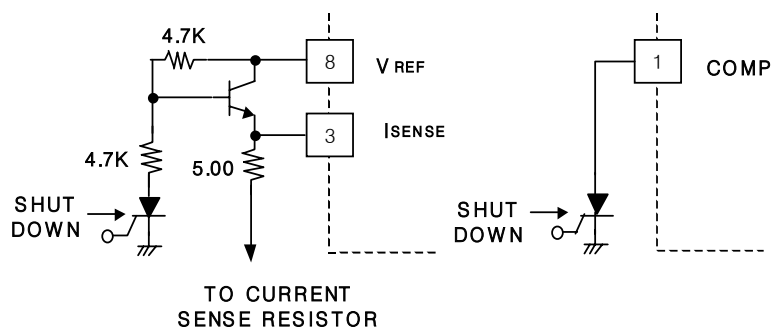

Shutdown of the S3882 can be accomplished by two methods; either raise pin3 above 1V or pull pin1 below a voltage two diodes drops above ground. Either causes the output of the PWM method comparator to be high (refer to

block diagram). The PWM latch is reset dominant so that the output will remain low until the next clock cycle after the shutdown condition at pins 1 and/or 3 is removed. In one example, an externally latched shutdown may be accomplished by adding an SCR which turn off, allowing the SCR to reset.

6. Open Loop Test

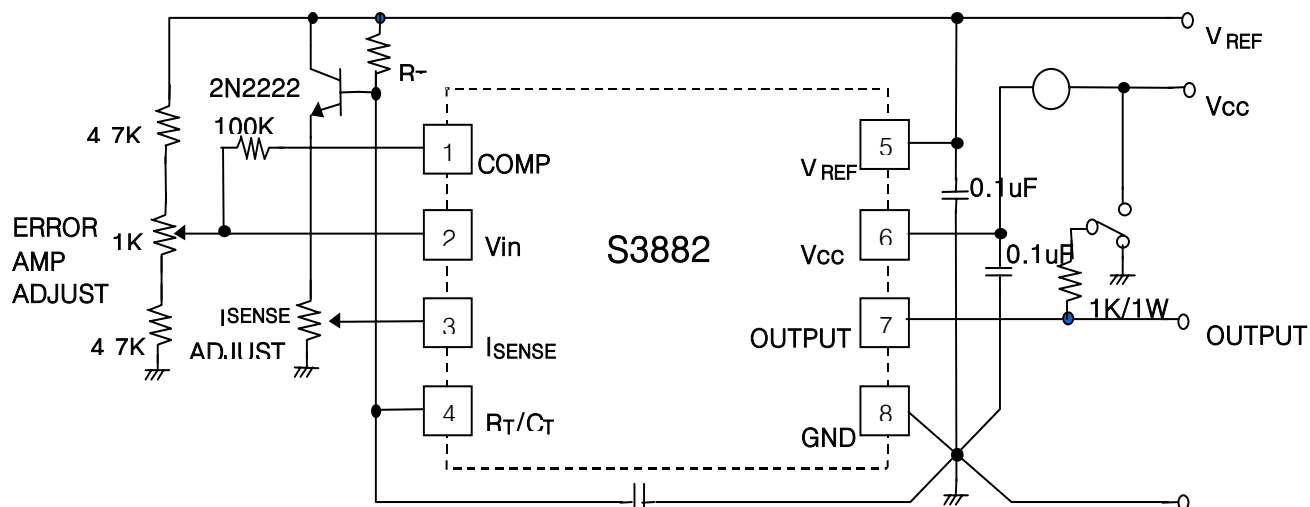

High peak currents associated with capacitive loads necessitate careful grounding techniques. Timing and bypass capacitors should be connected close to Pin5 in a single point ground. The transistor and 5 kΩ potentiometer are used to sample the oscillator waveform and apply an adjustable ramp to Pin 3.

7. Slope Compensation

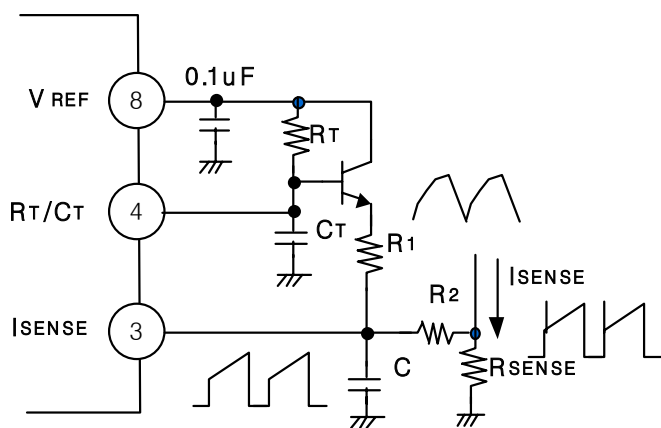

A fraction of the oscillator ramp can be resistively summed with the current sense signal to provide slope compensation for converters requiring duty cycle over 50%. Note that capacitor C, forms a filter with R₂ to suppress the leading edge switch spikes.

Electrical Characteristic Curves

OUTPUT DEAD-TIME vs. OSCILLATOR FREQUENCY

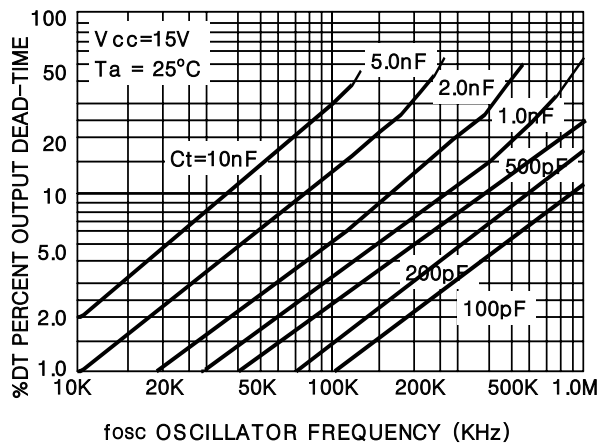

TIMING RESISTOR vs. OSCILLATOR FREQUENCY

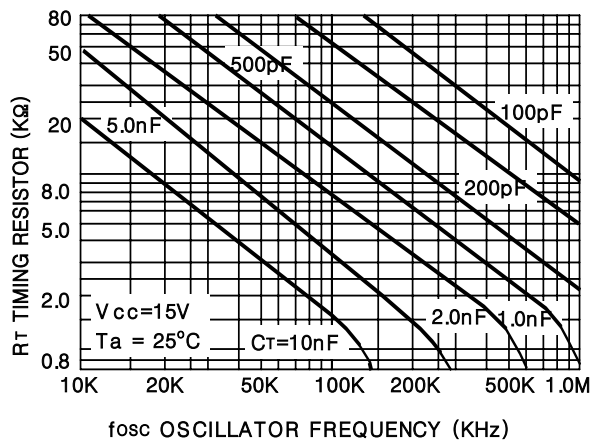

Error Amplifier Open-Loop Frequency Response

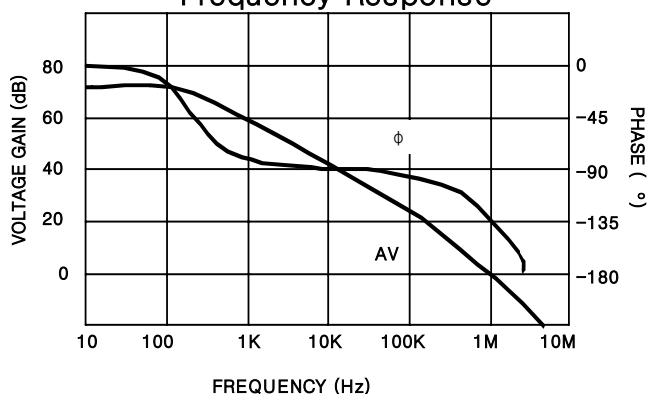

Output Saturation Characteristics

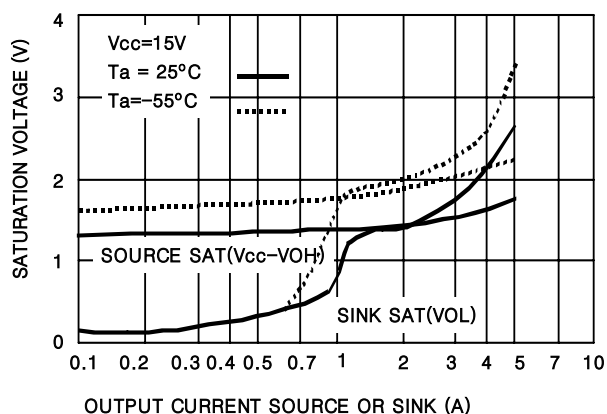

These AUK products are intended for usage in general electronic equipments(Office and communication equipment, measuring equipment, domestic electrification, etc.).

Please make sure that you consult with us before you use these AUK products in equipments which require high quality and/or reliability, and in equipments which could have major impact to the welfare of human life(atomic energy control, airplane, spaceship, traffic signal, combustion central, all types of safety device, etc.).

AUK cannot accept liability to any damage which may occur in case these AUK products were used in the mentioned equipments without prior consultation with AUK.