

S3C2501X

32-BIT RISC MICROPROCESSOR USER'S MANUAL

Revision 1



ELECTRONICS

Important Notice

The information in this publication has been carefully checked and is believed to be entirely accurate at the time of publication. Samsung assumes no responsibility, however, for possible errors or omissions, or for any consequences resulting from the use of the information contained herein.

Samsung reserves the right to make changes in its products or product specifications with the intent to improve function or design at any time and without notice and is not required to update this documentation to reflect such changes.

This publication does not convey to a purchaser of semiconductor devices described herein any license under the patent rights of Samsung or others.

Samsung makes no warranty, representation, or guarantee regarding the suitability of its products for any particular purpose, nor does Samsung assume any liability arising out of the application or use of any product or circuit and specifically disclaims any and all liability, including without limitation any consequential or incidental damages.

**S3C2501X RISC Microprocessor
User's Manual, Revision 1
Publication Number: 21-S3-C2501X-122002**

© 2002 Samsung Electronics

All rights reserved. No part of this publication may be reproduced, stored in a retrieval system, or transmitted in any form or by any means, electric or mechanical, by photocopying, recording, or otherwise, without the prior written consent of Samsung Electronics.

Samsung Electronics' Microprocessor business has been awarded full ISO-14001 certification (BSI Certificate No. FM24653). All semiconductor products are designed and manufactured in accordance with the highest quality standards and objectives.

Samsung Electronics Co., Ltd.
San #24 Nongseo-Ri, Kiheung-Eup
Yongin-City, Kyunggi-Do, Korea
C.P.O. Box #37, Suwon 449-900

TEL: (82)-(31)-209-2831
FAX: (82)-(31)-209-8309
Home-Page URL: <http://www.samsungsemi.com>

Printed in the Republic of Korea

"Typical" parameters can and do vary in different applications. All operating parameters, including "Typicals" must be validated for each customer application by the customer's technical experts.

Samsung products are not designed, intended, or authorized for use as components in systems intended for surgical implant into the body, for other applications intended to support or sustain life, or for any other application in which the failure of the Samsung product could create a situation where personal injury or death may occur.

Should the Buyer purchase or use a Samsung product for any such unintended or unauthorized application, the Buyer shall indemnify and hold Samsung and its officers, employees, subsidiaries, affiliates, and distributors harmless against all claims, costs, damages, expenses, and reasonable attorney fees arising out of, either directly or indirectly, any claim of personal injury or death that may be associated with such unintended or unauthorized use, even if such claim alleges that Samsung was negligent regarding the design or manufacture of said product.

Table of Contents

Chapter 1 Product Overview

1.1 Overview	1-1
1.2 Features	1-2
1.3 Block Diagram	1-4
1.4 Package Diagram	1-5
1.5 Pin Assignment.....	1-6
1.6 Signal Description.....	1-12
1.7 Pad Type	1-26
1.8 Special Registers.....	1-27

Chapter 2 Programmer's Model

2.1 Overview	2-1
2.2 Switching State	2-1
2.2.1 Entering THUMB State	2-1
2.2.2 Entering ARM State.....	2-1
2.3 Memory Formats.....	2-2
2.3.1 Big-Endian Format.....	2-2
2.3.2 Little-Endian Format	2-2
2.4 Instruction Length	2-3
2.5 Data Types	2-3
2.6 Operating Modes	2-3
2.7 Registers	2-4
2.7.3 The Relationship Between ARM and THUMB State Registers.....	2-7
2.7.4 Accessing Hi-Registers in THUMB State.....	2-8
2.8 The Program Status Registers	2-8
2.8.1 The Condition Code Flags	2-9
2.8.2 The Control Bits.....	2-9
2.9 Exceptions	2-11
2.9.1 Action on Entering an Exception	2-11
2.9.2 Action on Leaving an Exception.....	2-11
2.9.3 Exception Entry/Exit Summary	2-12
2.9.4 FIQ.....	2-12
2.9.5 IRQ.....	2-13
2.9.6 Abort	2-13
2.9.7 Software Interrupt.....	2-14
2.9.8 Undefined Instruction.....	2-14
2.10 Exception Vectors.....	2-14
2.10.1 Exception Priorities.....	2-15
2.10.2 Not All Exceptions Can Occur at Once:	2-15
2.11 Interrupt Latencies	2-16
2.12 Reset	2-16
2.13 Introduction for ARM940T	2-17
2.14 ARM940T Block Diagram.....	2-18
2.15 About The ARM940T Programmer's Model	2-19
2.15.1 Data Abort Model.....	2-20
2.15.2 Instruction Set Extension Spaces.....	2-20
2.16 ARM940T CP15 Registers	2-21
2.16.1 CP15 Register Map Summary	2-21

Table of Contents (Continued)

Chapter 3 Instruction Set

3.1 Instruction Set Summary	3-1
3.1.1 Format Summary	3-1
3.1.2 Instruction Summary	3-2
3.2 The Condition Field	3-4
3.3 Branch and Exchange (BX)	3-5
3.3.1 Instruction Cycle Times	3-5
3.3.2 Assembler Syntax	3-5
3.3.3 Using R15 as an Operand	3-5
3.4 Branch and Branch with Link (B, BL)	3-7
3.4.1 The Link Bit	3-7
3.4.2 Instruction Cycle Times	3-7
3.4.3 Assembler Syntax	3-8
3.5 Data Processing	3-9
3.5.1 CPSR Flags	3-11
3.5.2 Shifts	3-12
3.5.3 Immediate Operand Rotates	3-16
3.5.4 Writing to R15	3-16
3.5.5 Using R15 as an Operand	3-16
3.5.6 Teq, Tst, Cmp and CMN Opcodes	3-16
3.5.7 Instruction Cycle Times	3-17
3.5.8 Assembler Syntax	3-17
3.6 PSR Transfer (MRS, MSR)	3-19
3.6.1 Operand Restrictions	3-19
3.6.2 Reserved Bits	3-21
3.6.3 Instruction Cycle Times	3-21
3.6.4 Assembler Syntax	3-22
3.7 Multiply and Multiply-Accumulate (MUL, MLA)	3-23
3.7.1 CPSR Flags	3-24
3.7.2 Instruction Cycle Times	3-24
3.7.3 Assembler Syntax	3-24
3.8 Multiply Long and Multiply-Accumulate Long (MULL, MLAL)	3-25
3.8.1 Operand Restrictions	3-25
3.8.2 CPSR Flags	3-26
3.8.3 Instruction Cycle Times	3-26
3.8.4 Assembler Syntax	3-27
3.9 Single Data Transfer (LDR, STR)	3-28
3.9.1 Offsets and Auto-Indexing	3-29
3.9.2 Shifted Register Offset	3-29
3.9.3 Bytes and Words	3-29
3.9.4 Use of R15	3-31
3.9.5 Restriction on the Use of Base Register	3-31
3.9.6 Data Aborts	3-31
3.9.7 Instruction Cycle Times	3-31
3.9.8 Assembler Syntax	3-32

Table of Contents (Continued)

Chapter 3 Instruction Set (Continued)

3.10 Halfword and Signed Data Transfer (LDRH/STRH/LDRSB/LDRSH).....	3-34
3.10.1 Offsets and Auto-Indexing	3-35
3.10.2 Half-Word Load and Stores	3-36
3.10.3 Signed Byte and Half-Word Loads.....	3-36
3.10.4 Endianness and Byte/Half-Word Selection.....	3-36
3.10.5 Use of R15	3-37
3.10.6 Data Aborts.....	3-37
3.10.7 Instruction Cycle Times	3-37
3.10.8 Assembler Syntax.....	3-38
3.11 Block Data Transfer (LDM, STM)	3-40
3.11.1 The Register List.....	3-40
3.11.2 Addressing Modes	3-41
3.11.3 Address Alignment.....	3-41
3.11.4 Use of the S Bit	3-43
3.11.5 Use of R15 as the Base	3-43
3.11.6 Inclusion of the Base in the Register List.....	3-44
3.11.7 Data Aborts.....	3-44
3.11.8 Instruction Cycle Times	3-44
3.11.9 Assembler Syntax.....	3-45
3.12 Single Data Swap (SWP).....	3-47
3.12.1 Bytes and Words	3-47
3.12.2 Use of R15	3-47
3.12.3 Data Aborts.....	3-48
3.12.4 Instruction Cycle Times	3-48
3.12.5 Assembler Syntax.....	3-48
3.13 Software Interrupt (SWI)	3-49
3.13.1 Return from the Supervisor.....	3-49
3.13.2 Comment Field.....	3-49
3.13.3 Instruction Cycle Times	3-49
3.13.4 Assembler Syntax.....	3-50
3.14 Coprocessor Data Operations (CDP).....	3-51
3.14.1 Coprocessor Instructions.....	3-51
3.14.2 The Coprocessor Fields	3-51
3.14.3 Instruction Cycle Times	3-52
3.14.4 Assembler Syntax.....	3-52
3.15 Coprocessor Data Transfers (LDC, STC)	3-53
3.15.1 The Coprocessor Fields	3-53
3.15.2 Addressing Modes	3-54
3.15.3 Address Alignment.....	3-54
3.15.4 Use of R15	3-54
3.15.5 Data Aborts.....	3-54
3.15.6 Instruction Cycle Times	3-54
3.15.7 Assembler Syntax.....	3-55

Table of Contents (Continued)

Chapter 3 Instruction Set (Continued)

3.16 Coprocessor Register Transfers (MRC, MCR)	3-56
3.16.1 The Coprocessor Fields	3-56
3.16.2 Transfers to R15	3-57
3.16.3 Transfers from R15	3-57
3.16.4 Instruction Cycle Times	3-57
3.16.5 Assembler Syntax	3-57
3.17 Undefined Instruction	3-58
3.17.1 Instruction Cycle Times	3-58
3.17.2 Assembler Syntax	3-58
3.18 Instruction Set Examples	3-59
3.18.1 Using The Conditional Instructions	3-59
3.18.2 Pseudo-Random Binary Sequence Generator	3-61
3.18.3 Multiplication by Constant Using The Barrel Shifter	3-61
3.18.4 Loading a Word From an Unknown Alignment	3-63
3.19 Thumb Instruction Set Format	3-64
3.19.1 Format Summary	3-64
3.19.2 Opcode Summary	3-65
3.20 Format 1: Move Shifted Register	3-67
3.20.1 Operation	3-67
3.20.2 Instruction Cycle Times	3-67
3.21 Format 2: Add/Subtract	3-68
3.21.1 Operation	3-68
3.21.2 Instruction Cycle Times	3-69
3.22 Format 3: Move/Compare/Add/Subtract Immediate	3-70
3.22.1 Operations	3-70
3.22.2 Instruction Cycle Times	3-70
3.23 Format 4: ALU Operations	3-71
3.23.1 Operation	3-71
3.23.2 Instruction Cycle Times	3-72
3.24 Format 5: Hi-Register Operations/Branch Exchange	3-73
3.24.1 Operation	3-73
3.24.2 Instruction Cycle Times	3-74
3.24.3 The Bx Instruction	3-74
3.24.4 Using R15 as an Operand	3-75
3.25 Format 6: PC-Relative Load	3-76
3.25.1 Operation	3-76
3.25.2 Instruction Cycle Times	3-76
3.26 Format 7: Load/Store With Register Offset	3-77
3.26.1 Operation	3-77
3.26.2 Instruction Cycle Times	3-78
3.27 Format 8: Load/Store Sign-Extended Byte/Half-Word	3-79
3.27.1 Operation	3-79
3.27.2 Instruction Cycle Times	3-80

Table of Contents (Continued)

Chapter 3 Instruction Set (Continued)

3.28	Format 9: Load/Store with Immediate Offset.....	3-81
3.28.1	Operation.....	3-81
3.28.2	Instruction Cycle Times	3-82
3.29	Format 10: Load/Store Half-Word	3-83
3.29.1	Operation.....	3-83
3.29.2	Instruction Cycle Times	3-83
3.30	Format 11: SP-Relative Load/Store	3-84
3.30.1	Operation.....	3-84
3.30.2	Instruction Cycle Times	3-84
3.31	Format 12: Load Address.....	3-85
3.31.1	Operation.....	3-85
3.31.2	Instruction Cycle Times	3-86
3.32	Format 13: Add Offset to Stack Pointer.....	3-87
3.32.1	Operation.....	3-87
3.32.2	Instruction Cycle Times	3-87
3.33	Format 14: Push/Pop Registers.....	3-88
3.33.1	Operation.....	3-88
3.33.2	Instruction Cycle Times	3-89
3.34	Format 15: Multiple Load/Store	3-90
3.34.1	Operation.....	3-90
3.34.2	Instruction Cycle Times	3-90
3.35	Format 16: Conditional Branch.....	3-91
3.35.1	Operation.....	3-91
3.35.2	Instruction Cycle Times	3-92
3.36	Format 17: Software Interrupt	3-93
3.36.1	Operation.....	3-93
3.36.2	Instruction Cycle Times	3-93
3.37	Format 18: Unconditional Branch	3-94
3.37.1	Operation.....	3-94
3.38	Format 19: Long Branch With Link.....	3-95
3.38.1	Operation.....	3-95
3.38.2	Instruction Cycle Times	3-96
3.39	Instruction Set Examples	3-97
3.39.1	Multiplication by a Constant Using Shifts and Adds.....	3-97
3.39.2	General Purpose Signed Divide.....	3-98
3.39.3	Division by a Constant	3-100

Table of Contents (Continued)

Chapter 4 System Configuration

4.1 Overview	4-1
4.2 Features.....	4-1
4.3 Address Map.....	4-2
4.4 Remap of Memory Space	4-3
4.5 External Address Translation	4-3
4.6 Arbitration Scheme	4-4
4.6.1 Problem Solvings with Programmable Round-Robin	4-7
4.7 Clock Configuration.....	4-9
4.8 System Configuration Special Registers.....	4-15
4.8.1 System Configuration Register.....	4-16
4.8.2 Product Code and Revision Number Register	4-18
4.8.3 Clock Control Register	4-19
4.8.4 Peripheral Clock Disable Register.....	4-20
4.8.5 Clock Status Register	4-21
4.8.6 AHB Bus Master Priority Register	4-21
4.8.7 Core PLL Control Register	4-22
4.8.8 System Bus PLL Control Register	4-23
4.8.9 PHY PLL Control Register	4-24

Chapter 5 Memory Controller

5.1 Overview	5-1
5.2 Features.....	5-2
5.3 Memory Map.....	5-3
5.4 Bus Interface Signals	5-5
5.5 Endian Modes	5-7
5.6 Ext I/O Bank Controller	5-13
5.6.1 Features	5-13
5.6.2 External Device Connection.....	5-14
5.6.3 Ext. I/O Bank Controller Special Register.....	5-21
5.6.4 Timing Diagram	5-29
5.7 SDRAM Controller	5-38
5.7.1 Features	5-38
5.7.2 SDRAM Size and Configuration.....	5-39
5.7.3 Address Mapping.....	5-42
5.7.4 SDRAM Commands.....	5-44
5.7.5 External Data Bus Width.....	5-45
5.7.6 Merging Write Buffer	5-45
5.7.7 Self Refresh.....	5-45
5.7.8 Basic Operation	5-46
5.7.9 SDRAM Special Registers	5-47
5.7.10 SDRAM Controller Timing.....	5-54

Table of Contents (Continued)

Chapter 6 I²C Bus Controller

6.1 Overview	6-1
6.2 Features	6-1
6.3 Functional Description	6-2
6.4 I ² C Concepts	6-3
6.4.1 Basic Operation	6-3
6.4.2 General Characteristics	6-4
6.4.3 Bit Transfers	6-4
6.4.4 Data Validity	6-5
6.4.5 Start and Stop Conditions	6-5
6.4.6 Data Transfer Operations	6-6
6.5 I ² C Special Registers	6-8
6.5.1 Control Status Register	6-8
6.5.2 Shift Buffer Register	6-10
6.5.3 Prescaler Register	6-10
6.5.4 Prescaler Counter Register	6-11
6.5.5 Interrupt Pending Register	6-11

Chapter 7 Ethernet Controller

7.1 Overview	7-1
7.2 Features	7-2
7.3 MAC Function Blocks.....	7-3
7.3.1 Media Independent Interface (MII)	7-3
7.3.2 Physical Layer Entity (PHY)	7-4
7.3.3 Buffered Dma Interface (BDI)	7-4
7.3.4 The MAC Transmitter Block.....	7-4
7.3.5 The MAC Receiver Block.....	7-6
7.3.6 Flow Control Block.....	7-7
7.3.7 Buffered DMA (BDMA) Overview	7-7
7.4 Ethernet Controller Special Registers.....	7-13
7.4.1 BDMA Relative Special Register	7-15
7.4.2 MAC Relative Special Register.....	7-24
7.5 Ethernet Operations.....	7-37
7.5.1 MAC Frame Format.....	7-37
7.5.2 The MII Station Manager	7-45
7.5.3 Full-Duplex Pause Operations	7-46
7.5.4 Error Signalling.....	7-48
7.5.5 Timing Parameters for MII Transactions	7-50

Table of Contents (Continued)

Chapter 8 DES/3DES

8.1 Overview	8-1
8.2 Feature	8-1
8.3 DES/3DES Special Registers.....	8-3
8.3.1 DES/3DES Control Register.....	8-4
8.3.2 DES/3DES Status Register.....	8-5
8.3.3 DES/3DES Interrupt Enable Register.....	8-6
8.3.4 DES/3DES Run Enable Register.....	8-6
8.3.5 DES/3DES Key1 Left/Right Side Register.....	8-6
8.3.6 DES/3DES Key 2 Left/Right Side Register.....	8-7
8.3.7 DES/3DES Key 3 Left Side Register.....	8-7
8.3.8 DES/3DES IV Left/Right Side Register.....	8-7
8.3.9 DES/3DES Input/Output Data FIFO Register.....	8-8
8.4 DES/3DES Operation.....	8-9
8.5 Performance Calculation Guide	8-10

Chapter 9 GDMA Controller

9.1 Overview	9-1
9.2 Feature	9-1
9.3 GDMA Special Registers.....	9-3
9.3.1 GDMA Programmable Priority Registers.....	9-4
9.3.2 GDMA Control Registers.....	9-9
9.3.3 GDMA Source/Destination Address Registers.....	9-12
9.3.4 GDMA Transfer Count Registers.....	9-13
9.3.5 GDMA Run Enable Registers.....	9-14
9.3.6 GDMA Interrupt Pending Register.....	9-15
9.4 GDMA Mode Operation.....	9-16
9.4.1 Software Mode.....	9-16
9.4.2 External GDMA Request Mode	9-16
9.4.3 HUART Mode	9-16
9.4.4 DES Mode	9-17
9.5 GDMA Function Description.....	9-17
9.5.1 GDMA Transfers.....	9-17
9.5.2 Starting/Ending GDMA Transfers.....	9-17
9.5.3 Data Transfer Modes	9-18
9.6 GDMA Transfer Timing Data.....	9-19
9.6.1 Single and One Data Burst Mode	9-20
9.6.2 Single and Four Data Burst Mode	9-21
9.6.3 Block and One Data Burst Mode.....	9-22
9.6.4 Block and Four Data Burst	9-23

Table of Contents (Continued)

Chapter 10 Serial I/O (Console UART)

10.1 Overview	10-1
10.2 Features	10-1
10.3 Console UART Special Registers	10-3
10.3.1 Console UART Control Registers	10-4
10.3.2 Console UART Status Registers	10-8
10.3.3 Console UART Interrupt Enable Register	10-11
10.3.4 UART Transmit Data Register	10-13
10.3.5 UART Receive Data Register	10-14
10.3.6 UART Baud Rate Divisor Register	10-15
10.3.7 Console UART Baud Rate Examples	10-16
10.3.8 UART Control Character Register 1 and 2	10-17

Chapter 11 Serial I/O (High-Speed UART)

11.1 Overview	11-1
11.2 Features	11-1
11.3 High-Speed UART Special Registers	11-3
11.3.1 High-Speed UART Control Registers	11-4
11.3.2 High-Speed UART Status Registers	11-9
11.3.3 High-Speed UART Interrupt Enable Register	11-14
11.3.4 High-Speed UART Transmit Buffer Register	11-16
11.3.5 High-Speed UART Receive Buffer Register	11-17
11.3.6 High-Speed UART Baud Rate Divisor Register	11-18
11.3.7 High-Speed UART Baud Rate Examples	11-19
11.3.8 High-Speed UART Control Character 1 Register	11-20
11.3.9 High-Speed UART Control Character 2 Register	11-21
11.3.10 High-Speed UART Autobaud Boundary Register	11-22
11.3.11 High-Speed UART Autobaud Table Register	11-23
11.4 High-Speed UART Operation	11-24
11.4.1 FIFO Operation	11-24
11.4.2 Hardware Flow Control	11-24
11.4.3 Software Flow Control	11-26
11.4.4 Auto Baud Rate Detection	11-26

Chapter 12 I/O Ports

12.1 Overview	12-1
12.2 Features	12-1
12.3 I/O Port Special Register	12-2
12.3.1 I/O Port Mode Select Register	12-2
12.3.2 I/O Port Function Control Register	12-4
12.3.3 I/O Port Control Register for GDMA	12-7
12.3.4 I/O Port Control Register for External Interrupt	12-8
12.3.5 I/O Port External Interrupt Clear Register	12-10
12.3.6 I/O Port Data Register	12-11
12.3.7 I/O Port Drive Control Register	12-11

Table of Contents (Concluded)

Chapter 13 Interrupt Controller

13.1 Overview	13-1
13.2 Features.....	13-1
13.3 Interrupt Sources.....	13-2
13.4 Interrupt Controller Special Registers	13-3
13.4.1 Interrupt Mode Registers.....	13-3
13.4.2 Interrupt Mask Registers	13-5
13.4.3 Interrupt Priority Registers	13-8
13.4.4 Interrupt Offset Register.....	13-9
13.4.5 Interrupt by Priority Register	13-12
13.4.6 Interrupt Test Register	13-12

Chapter 14 32-bit Timers

14.1 Overview	14-1
14.2 Feature	14-1
14.3 Interval Mode Operation.....	14-2
14.4 Toggle Mode Operation.....	14-2
14.5 Timer Operation Guidelines	14-3
14.6 Timer Special Register.....	14-4
14.6.1 Timer Mode Register	14-4
14.6.2 Timer Data Registers	14-6
14.6.3 Timer Count Registers	14-7
14.6.4 Timer Interrupt Clear Registers	14-8
14.6.5 Watchdog Timer Register	14-9

Chapter 15 Electrical Data

15.1 Overview	15-1
15.2 Absolute Maximum Ratings.....	15-1
15.3 Recommended Operating Conditions	15-1
15.4 DC Electrical Specifications	15-2
15.5 AC Electrical Characteristics	15-4

Chapter 16 Mechanical Data

16.1 Overview	16-1
---------------------	------

List of Figures

Figure Number	Title	Page Number
1-1	S3C2501X Block Diagram	1-4
1-2	S3C2501X Pin Assignment Diagram	1-5
2-1	Big-Endian Addresses of Bytes within Words.....	2-2
2-2	Little-Endian Addresses of Bytes Words	2-2
2-3	Register Organization in ARM State	2-5
2-4	Register Organization in THUMB State	2-6
2-5	Mapping of THUMB State Registers onto ARM State Registers.....	2-7
2-6	Program Status Register Format	2-8
2-7	ARM940T Block Diagram	2-18
3-1	ARM Instruction Set Format	3-1
3-2	Branch and Exchange Instructions.....	3-5
3-3	Branch Instructions	3-7
3-4	Data Processing Instructions	3-9
3-5	ARM Shift Operations.....	3-12
3-6	Logical Shift Left	3-12
3-7	Logical Shift Right	3-13
3-8	Arithmetic Shift Right	3-13
3-9	Rotate Right	3-14
3-10	Rotate Right Extended	3-14
3-11	PSR Transfer	3-20
3-12	Multiply Instructions.....	3-23
3-13	Multiply Long Instructions	3-25
3-14	Single Data Transfer Instructions.....	3-28
3-15	Little-Endian Offset Addressing	3-30
3-16	Half-word and Signed Data Transfer with Register Offset	3-34
3-17	Half-word and Signed Data Transfer with Immediate Offset and Auto-Indexing	3-35
3-18	Block Data Transfer Instructions	3-40
3-19	Post-Increment Addressing.....	3-41
3-20	Pre-Increment Addressing	3-42
3-21	Post-Decrement Addressing	3-42
3-22	Pre-Decrement Addressing.....	3-43
3-23	Swap Instruction	3-47
3-24	Software Interrupt Instruction.....	3-49
3-25	Coprocessor Data Operation Instruction	3-51
3-26	Coprocessor Data Transfer Instructions	3-53
3-27	Coprocessor Register Transfer Instructions	3-56
3-28	Undefined Instruction.....	3-58
3-29	THUMB Instruction Set Formats	3-64

List of Figures (Continued)

Figure Number	Title	Page Number
3-30	Format 1.....	3-67
3-31	Format 2.....	3-68
3-32	Format 3.....	3-70
3-33	Format 4.....	3-71
3-34	Format 5.....	3-73
3-35	Format 6.....	3-76
3-36	Format 7.....	3-77
3-37	Format 8.....	3-79
3-38	Format 9.....	3-81
3-39	Format 10.....	3-83
3-40	Format 11.....	3-84
3-41	Format 12.....	3-85
3-42	Format 13.....	3-87
3-43	Format 14.....	3-88
3-44	Format 15.....	3-90
3-45	Format 16.....	3-91
3-46	Format 17.....	3-93
3-47	Format 18.....	3-94
3-48	Format 19.....	3-95
4-1	S3C2501X Address map after reset	4-2
4-2	External Address Bus Diagram	4-4
4-3	Priority Groups of S3C2501X.....	4-5
4-4	AHB Programmable Priority Registers	4-6
4-5	Shows the Clock Generation Logic of the S3C2501X.....	4-14
4-6	Divided System Clock Timing Diagram.....	4-19
5-1	Memory Bank Address map.....	5-4
5-2	Memory Controller Bus Signals.....	5-6
5-3	8-bit ROM, SRAM and Flash Basic Connection	5-14
5-4	8-bit ROM, SRAM and Flash Basic Connection (8-bit Memory x 2).....	5-15
5-5	16-bit SRAM Basic Connection.....	5-16
5-6	16-bit ROM and Flash Basic Connection	5-17
5-7	16-bit ROM Basic Connection 2.....	5-18
5-8	16-bit SRAM Basic Connection 2.....	5-19
5-9	ROM & SRAM with Muxed Address & Data Bus Connection.....	5-20
5-10	BnCON.....	5-22
5-11	Bank n Control (BnCON) Register Configuration.....	5-24
5-12	Muxed Bus Control (MUXBCON) Register Configuration	5-26
5-13	Wait Control (WAITCON) Register Configuration	5-28

List of Figures (Continued)

Figure Number	Title	Page Number
5-14	Read Timing Diagram 1	5-29
5-15	Write Timing Diagram 1	5-30
5-16	Read Timing Diagram 2	5-31
5-17	Write Timing Diagram 2	5-32
5-18	Read after Write at the Same Bank (COHDIS = 1)	5-33
5-19	Read Timing Diagram (Muxed Bus).....	5-34
5-20	Write Timing Diagram (Muxed Bus)	5-35
5-21	Write Timing Diagram (nEWAIT).....	5-36
5-22	Write Timing Diagram (nREADY).....	5-37
5-23	SDRAM Configuration Register 0	5-49
5-24	SDRAM Command Register	5-51
5-25	SDRAM Refresh Timer Register	5-52
5-26	SDRAM Write Buffer Time-out Register	5-53
5-27	Single Read Operation (CAS Latency=2).....	5-54
5-28	Single Read Operation (CAS Latency=3).....	5-55
5-29	Single Write Operation	5-56
5-30	Burst Read Operation (CAS Latency = 2)	5-57
5-31	Burst Read Operation (CAS Latency = 3)	5-58
5-32	Burst Write Operation.....	5-59
6-1	I ² C Block Diagram.....	6-1
6-2	Master Transmitter and Slave Receiver.....	6-3
6-3	Master Receiver and Slave Transmitter.....	6-4
6-4	Start and Stop Conditions.....	6-5
6-5	Data Transfer Format	6-7
6-6	I ² C Control Status Register.....	6-10
7-1	Ethernet Diagram	7-1
7-2	Data Structure of Tx Buffer Descriptor.....	7-10
7-3	Data Structure of Rx Buffer Descriptor	7-11
7-4	Data Structure of the Receive Frame	7-12
7-5	Fields of an IEEE802.3/Ethernet Frame	7-38
7-6	CSMA/CD Transmit Operation	7-40
7-7	Timing for Transmission without Collision.....	7-41
7-8	Timing for Transmission with Collision in Preamble.....	7-42
7-9	Receiving Frame without Error	7-43
7-10	Receiving Frame with Error	7-43
7-11	CSMA/CD Receive Operation	7-44
7-12	MAC Control Frame Format	7-46
7-13	Timing Relationship of Transmission Signals at MII.....	7-50
7-14	Timing Relationship of Reception Signals at MII.....	7-50
7-15	MDIO Sourced by PHY.....	7-50
7-16	MDIO Sourced by STA.....	7-50
8-1	DES/3DES Block Diagram	8-2

List of Figures (Continued)

Figure Number	Title	Page Number
9-1	GDMA Controller Block Diagram	9-2
9-2	GDMA Programmable Priority Registers.....	9-5
9-3	GDMA Control Register.....	9-11
9-4	GDMA Source/Destination Address Register	9-12
9-5	GDMA Transfer Count Register	9-13
9-6	GDMA Run Enable Register	9-14
9-7	GDMA Interrupt Pending Register.....	9-15
9-8	External GDMA Requests (Single Mode)	9-18
9-9	External GDMA Requests (Block Mode)	9-18
9-10	External GDMA Requests Detailed Timing	9-19
9-11	Single and One Data Burst Mode Timing	9-20
9-12	Single and Four Data Burst Mode Timing	9-21
9-13	Block and One Data Burst Mode Timing	9-22
9-14	Block and Four Data Burst Timing	9-23
10-1	Console UART Block Diagram.....	10-2
10-2	Console UART Control Register	10-6
10-3	Console UART Control Register	10-7
10-4	Console UART Status Register.....	10-10
10-5	Console UART Interrupt Enable Register.....	10-12
10-6	Console UART Transmit Data Register.....	10-13
10-7	Console UART Receive Data Register.....	10-14
10-8	Console UART Baud Rate Divisor Register	10-15
10-9	Console UART Baud Rate Generator (BRG).....	10-16
10-10	Console UART Control Character 1 Register	10-17
10-11	Console UART Control Character 2 Register	10-17
10-12	Interrupt-Based Serial I/O Transmit and Receive Timing Diagram.....	10-18
10-13	Serial I/O Frame Timing Diagram (Normal Console UART)	10-19
10-14	Infra-Red Transmit Mode Frame Timing Diagram.....	10-19
10-15	Infra-Red Receive Mode Frame Timing Diagram.....	10-20
11-1	High-Speed UART Block Diagram	11-2
11-2	High-Speed UART Control Register.....	11-7
11-3	High-Speed UART Status Register	11-12
11-4	High-Speed UART Interrupt Enable Register	11-15
11-5	High-Speed UART Transmit Buffer Register.....	11-16
11-6	High-Speed UART Receive Buffer Register.....	11-17
11-7	High-Speed UART Baud Rate Divisor Register.....	11-18
11-8	High-Speed UART Baud Rate Generator (BRG).....	11-19
11-9	High-Speed UART Control Character 1 Register.....	11-20
11-10	High-Speed UART Control Character 2 Register.....	11-21

List of Figures (Concluded)

Figure Number	Title	Page Number
11-11	AutoBaud Boundary Register Range	11-22
11-12	High-Speed UART AutoBaud Boundary Register.....	11-22
11-13	Example of AutoBaud Table Register Setting.....	11-23
11-14	High-Speed UART AutoBaud Table Register.....	11-23
11-15	When CTS Signal Level is High During Transmit Operation	11-25
11-16	When CTS Signal Level is Low During Transmit Operation	11-25
11-17	Normal Received Rx Data.....	11-26
11-18	DCD Lost During Rx Data Receive	11-26
11-19	Interrupt-Based Serial I/O Transmit and Receive Timing Diagram.....	11-27
11-20	DMA-Based Serial I/O Timing Diagram (Tx Only).....	11-28
11-21	DMA-Based Serial I/O Timing Diagram (Rx Only)	11-28
11-22	Serial I/O Frame Timing Diagram (Normal High-Speed UART)	11-29
11-23	Infra-Red Transmit Mode Frame Timing Diagram.....	11-29
11-24	Infra-Red Receive Mode Frame Timing Diagram	11-30
12-1	I/O Port Mode Registers 1/2	12-3
12-2	I/O Function Control Register 1	12-5
12-3	I/O Function Control Register 2	12-6
12-4	I/O Port Control Register for GDMA.....	12-7
12-5	I/O Port Control Register for External Interrupt	12-9
12-6	I/O Port External Interrupt Clear Register	12-10
13-1	Internal Interrupt Mode Register	13-4
13-2	External Interrupt Mode Register	13-5
13-3	Internal Interrupt Mask Register.....	13-6
13-4	External Interrupt Mask Register	13-7
13-5	Interrupt Priority Register.....	13-8
14-1	Timer Output Signal Timing.....	14-2
14-2	32-Bit Timer Block Diagram	14-3
14-3	Timer Mode Register.....	14-5
14-4	Timer Data Registers.....	14-6
14-5	Timer Count Registers.....	14-7
14-6	Timer Interrupt Clear Register	14-8
14-7	Watchdog Timer Register.....	14-9
16-1	272-BGA-2727-AN Package Dimensions.....	16-2

List of Tables

Table Number	Title	Page Number
1-1	S3C2501X Signal Descriptions	1-12
1-2	S3C2501X Pad Type and Feature	1-26
1-3	S3C2501X System Configuration	1-27
1-4	S3C2501X Memory Controller	1-27
1-5	S3C2501X SDRAM Controller	1-27
1-6	S3C2501X IIC Controller	1-28
1-7	S3C2501X Ethernet Controller 0.....	1-28
1-8	S3C2501X Ethernet Controller 1.....	1-29
1-9	S3C2501X DES Controller.....	1-30
1-10	S3C2501X GDMA Controller	1-31
1-11	S3C2501X Console UART Controller.....	1-32
1-12	S3C2501X High speed UART Controller.....	1-32
1-13	S3C2501X I/O Port Controller.....	1-33
1-14	S3C2501X Interrupt Controller.....	1-33
1-15	S3C2501X Timer Controller.....	1-34
2-1	PSR Mode. Bit Values	2-10
2-2	Exception Entry/Exit	2-12
2-3	Exception Vectors	2-14
2-4	ARM9TDMI Implementation Option.....	2-19
2-5	CP15 Register Map	2-21
2-6	ID Code Register	2-21
2-7	Cache Type Register Format.....	2-22
2-8	CP15 Register 1	2-23
2-9	Clocking Modes.....	2-23
2-10	Cacheable Register Format.....	2-24
2-11	Write Buffer Control Register	2-25
2-12	Protection Space Register Format.....	2-26
2-13	Permission Encoding.....	2-26
2-14	CP15 Data Protection Region Registers	2-27
2-15	CP15 Instruction Protection Region Registers	2-27
2-16	CP15 Protection Region Register Format	2-28
2-17	Area Size Encoding.....	2-28
2-18	Cache Operations Writing to Register 7.....	2-29
2-19	CP15 Register 7 Index/Segment Data Format.....	2-30
2-20	CP15 Register 7 Prefetch Address Format	2-30
2-21	Lockdown Register Format.....	2-31
2-22	CP15 Register 15	2-32

List of Tables (Continued)

Table Number	Title	Page Number
3-1	The ARM Instruction Set.....	3-2
3-2	Condition Code Summary.....	3-4
3-3	ARM Data Processing Instructions.....	3-11
3-4	Incremental Cycle Times.....	3-17
3-5	Assembler Syntax Descriptions.....	3-27
3-6	Addressing Mode Names.....	3-45
3-7	THUMB Instruction Set Opcodes.....	3-65
3-8	Summary of Format 1 Instructions.....	3-67
3-9	Summary of Format 2 Instructions.....	3-68
3-10	Summary of Format 3 Instructions.....	3-70
3-11	Summary of Format 4 Instructions.....	3-71
3-12	Summary of Format 5 Instructions.....	3-74
3-13	Summary of PC-Relative Load Instruction.....	3-76
3-14	Summary of Format 7 Instructions.....	3-77
3-15	Summary of format 8 instructions.....	3-79
3-16	Summary of Format 9 Instructions.....	3-81
3-17	Half-word Data Transfer Instructions.....	3-83
3-18	SP-Relative Load/Store Instructions.....	3-84
3-19	Load Address.....	3-85
3-20	The ADD SP Instruction.....	3-87
3-21	PUSH and POP Instructions.....	3-88
3-22	The Multiple Load/Store Instructions.....	3-90
3-23	The Conditional Branch Instructions.....	3-91
3-24	The SWI Instruction.....	3-92
3-25	Summary of Branch Instruction.....	3-93
3-26	The BL Instruction.....	3-94
4-1	The Base Address of Remapped Memory.....	4-3
4-2	AHB Bus Priorities for Arbitration.....	4-4
4-3	Clock Frequencies for CLKMOD Pins, CPU_FREQ Pins, and BUS_FREQ Pins....	4-9
4-4	P, M, S values of the S3C2501X PLL.....	4-13
4-5	System Configuration Registers.....	4-15

List of Tables (Continued)

Table Number	Title	Page Number
5-1	Base Address of Each Bank	5-3
5-2	Bus Interface Signals.....	5-5
5-3	External 32-bit Datawidth Store Operation with Big-Endian.....	5-7
5-4	External 32-bit Datawidth Load Operation with Big-Endian	5-7
5-5	External 16-bit Datawidth Store Operation with Big-Endian.....	5-8
5-6	External 16-bit Datawidth Load Operation with Big-Endian	5-8
5-7	External 8-bit Datawidth Store Operation with Big-Endian	5-9
5-8	External 8-bit Datawidth Load Operation with Big-Endian	5-9
5-9	External 32-bit Datawidth Store Operation with Little-Endian	5-10
5-10	External 32-bit Datawidth Load Operation with Little-Endian	5-10
5-11	External 16-bit Datawidth Store Operation with Little-Endian	5-11
5-12	External 16-bit Datawidth Load Operation with Little-Endian	5-11
5-13	External 8-bit Datawidth Store Operation with Little-Endian	5-12
5-14	External 8-bit Datawidth Load Operation with Little-Endian.....	5-12
5-15	Ext. I/O Bank Controller Special Registers	5-21
5-16	Bank n Control (BnCON) Register	5-23
5-17	Muxed Bus Control Register	5-25
5-18	WAIT Control Register	5-27
5-19	Supported SDRAM Configuration of 32-bit External Bus.....	5-40
5-20	Supported SDRAM Configuration of 16-bit External Bus.....	5-41
5-21	SDRAM Address Mapping of 32-bit External Bus	5-42
5-22	SDRAM address mapping of 16-bit external bus.....	5-43
5-23	SDRAM commands.....	5-44
5-24	SDRAM Special Registers.....	5-47
5-25	SDRAM Configuration Register	5-47
5-26	SDRAM Command Register.....	5-50
5-27	SDRAM Refresh Timer Register.....	5-52
5-28	SDRAM Write Buffer Time-out Register	5-53
6-1	Control Status Register.....	6-8
6-2	IICCON Register Description	6-8
6-3	IICBUF Register	6-10
6-4	IICPS Register	6-10
6-5	IICCNT Register.....	6-11
6-6	IICPND Register.....	6-11

List of Tables (Continued)

Table Number	Title	Page Number
7-1	MAC Function Block Descriptions	7-3
7-2	ETHERNET 0 Special Registers	7-13
7-3	ETHERNET 1 Special Registers	7-14
7-4	BDMATXCON Register	7-15
7-5	BDMA RXCON Register	7-16
7-6	BDMATXDPTR Register	7-17
7-7	BDMARXDPTR Register	7-17
7-8	BTXBDCNT Register	7-18
7-9	BRXBDCNT Register	7-18
7-10	BMTXINTEN Register	7-19
7-11	BMTXSTAT Register	7-20
7-12	BMRXINTEN Register	7-21
7-13	BMRXSTAT Register	7-22
7-14	BDMARXLEN Register	7-23
7-15	CFTXSTAT Register	7-24
7-16	MACCON Register	7-25
7-17	CAMCON Register	7-26
7-18	MACTXCON Register	7-27
7-19	MACTXSTAT Register	7-28
7-20	MACRXCON Register	7-29
7-21	MACRXSTAT Register	7-30
7-22	STADATA Register	7-31
7-23	STACON Register	7-32
7-24	CAMEN Register	7-33
7-25	MISSCNT Register	7-34
7-26	PZCNT Register	7-35
7-27	RMPZCNT Register	7-35
7-28	CAM Register	7-36
7-29	MAC Frame Format Description	7-37
7-30	STA Frame Structure Description	7-45

List of Tables (Continued)

Table Number	Title	Page Number
8-1	DES/3DES Special Registers Overview	8-3
8-2	DES/3DES Control Register Description.....	8-4
8-3	DES/3DES Status Register Description	8-5
8-4	DES/3DES Interrupt Enable Register Description	8-6
8-5	DES/3DES Run Enable Register Description.....	8-6
8-6	DES/3DES Key1 Left Side Register Description	8-6
8-7	DES/3DES Key 1 Right Side Register Description.....	8-6
8-8	DES/3DES Key 2 Left Side Register Description	8-7
8-9	DES/3DES Key 2 Right Side Register Description.....	8-7
8-10	DES/3DES Key 3 Left Side Register Description	8-7
8-11	DES/3DES Key 3 Right Side Register Description.....	8-7
8-12	DES/3DES IV Left Side Register Description.....	8-7
8-13	DES/3DES IV Right Side Register Description	8-7
8-14	DES/3DES Input Data FIFO Description.....	8-8
8-15	DES/3DES Output Data FIFO Description	8-8
9-1	GDMA Special Registers Overview	9-3
9-2	GDMA Programmable Priority Registers	9-4
9-3	DCON0/1/2/3/4/5 Registers	9-9
9-4	GDMA Control Register Description	9-9
9-5	DSAR0/1/2/3/4/5 and DDAR0/1/2/3/4/5 Registers.....	9-12
9-6	DTCR0/1/2/3/4/5 Registers.....	9-13
9-7	DRER0/1/2/3/4/5 Registers.....	9-14
9-8	DIPR0/1/2/3 Registers.....	9-15

List of Tables (Continued)

Table Number	Title	Page Number
10-1	Console UART Special Registers Overview.....	10-3
10-2	CUCON Registers	10-4
10-3	Console UART Control Register Description.....	10-4
10-4	CUSTAT Registers	10-8
10-5	Console UART Status Register Description	10-8
10-6	CUINT Registers	10-11
10-7	Console UART Interrupt Enable Register Description	10-11
10-8	CUTXBUF Registers.....	10-13
10-9	Console UART Transmit Register Description.....	10-13
10-10	CURXBUF Registers	10-14
10-11	Console UART Receive Register Description	10-14
10-12	CUBRD Registers.....	10-15
10-13	Typical Baud Rates Examples of Console UART	10-16
10-14	CUCHAR 1, 2 Registers	10-17
11-1	High-Speed UART Special Registers Overview.....	11-3
11-2	High-Speed UART Control Register.....	11-4
11-3	High-Speed UART Control Register Description	11-4
11-4	High-Speed UART Status Register	11-9
11-5	High-Speed UART Status Register Description.....	11-9
11-6	High-Speed UART Interrupt Enable Register	11-14
11-7	High-Speed UART Interrupt Enable Register Description.....	11-14
11-8	High-Speed UART Transmit Register	11-16
11-9	High-Speed UART Transmit Register Description.....	11-16
11-10	High-Speed UART Receive Register	11-17
11-11	High-Speed UART Receive Register Description.....	11-17
11-12	High-Speed UART Transmit Register	11-18
11-13	Typical Baud Rates Examples of High-Speed UART	11-19
11-14	High-Speed UART Control Character 1 Register	11-20
11-15	High-Speed UART Control Character 2 Register.....	11-21
11-16	High-Speed UART AutoBaud Boundary Register.....	11-22
11-17	High-Speed UART AutoBaud Table Register	11-23
12-1	I/O Port Special Registers	12-2
12-2	IOPMODE1/2 Registers.....	12-2
12-3	IOPCON1/2 Register	12-4
12-4	IOPGDMA Register	12-7
12-5	IOPEXTINT Register	12-8
12-6	IOPEXTINTPND Register.....	12-10
12-7	IOPDATA1/2 Register.....	12-11
12-8	IOPDRV1/2 Register.....	12-11

List of Tables (Concluded)

Table Number	Title	Page Number
13-1	S3C2501X Internal Interrupt Sources.....	13-2
13-2	S3C2501X External Interrupt Sources	13-3
13-3	INTMOD, EXTMOD Register	13-3
13-4	INTMASK, EXTMASK Register	13-5
13-5	Interrupt Priority Register.....	13-8
13-6	INTOFFSET_FIQ, INTOFFSET_IRQ Register	13-9
13-7	Index Value of Interrupt Sources	13-10
13-8	IPRIORHI, IPRIORLO Register	13-12
13-9	INTTSTHI, INTTSTLO Register.....	13-12
14-1	TMOD Register	14-4
14-2	TDATA0 - TDATA5 Registers	14-6
14-3	TCNT0 - TCNT5 Registers	14-7
14-4	Timer Interrupt Clear Registers.....	14-8
14-5	WDT Register	14-9
14-6	Watchdog Timer Timeout Value	14-10
15-1	Absolute Maximum Ratings.....	15-1
15-2	Recommended Operating Conditions	15-1
15-3	D.C Electric Characteristics	15-2
15-4	Operating Frequency.....	15-4
15-5	Clock AC timing specification-	15-4
15-6	AC Electrical Characteristics for S3C2501X.....	15-5

1

PRODUCT OVERVIEW

1.1 OVERVIEW

Samsung's S3C2501X 16/32-bit RISC microcontroller is a cost-effective, high-performance microcontroller solution for Ethernet-based systems, for example, SOHO router, internet gateway, WLAN AP, etc. A variety of communication features are embedded into S3C2501X required in many communication areas, including two Ethernet MACs, a high speed UART, and a console UART. A security feature is also supported by DES/3DES accelerator.

This highly integrated microcontroller enables customers to save system costs and increase performance over other 32-bit microcontroller.

The S3C2501X is built based on an outstanding CPU core: The ARM940T cached processor is a member of the ARM9 Thumb family of high-performance 32-bit system-on-a-chip processor solutions.

It provides a complete high performance CPU subsystem, including ARM9TDMI RISC integer CPU, 4KB instruction/data caches, write buffer, and protection unit, with an AMBA bus interface.

The ARM9TDMI core within the ARM940T executes both the 32-bit ARM and 16-bit Thumb instruction sets, allowing the user to trade off between high performance and high code density.

It is binary compatible with ARM7TDMI, ARM10TDMI, and Strong ARM processors, and is supported by a wide range of tools, operating systems, and application software.

The following integrated on-chip functions are described in detail in this user's manual :

- ARM940T cached processor
- Ethernet Controller
- GDMA Controller
- UART Controller
- I²C Controller
- Programmable I/O ports
- Interrupt Controller

1.2 FEATURES

ARM940T Core processor

- Fully 16/32-bit RISC architecture.
- Harvard cache architecture with separate 4KB Instruction and Data cache
- Protection unit to partition memory and set individual protection attributes for each partition
- AMBA Bus architecture
- Up to 166MHz operating frequency

Memory Controller

- 24-bit External Address Pins
- 2 Banks for SDRAM with 16/32 bit external bus.
- 8 Banks for Flash/ROM/SRAM/External I/O with 8/16/32-bit external bus.
- One External Bus Master with Bus Request/Acknowledge Pins

Ethernet Controllers

- Buffered DMA (BDMA) engine using burst mode
- BDMA Tx/Rx buffers (256-byte/256-byte)
- MAC Tx/Rx FIFOs (80-byte/16-byte) to support re-transmit after collision without DMA request
- Data alignment logic
- Support for old and new media (compatible with existing 10M-bit/s networks)
- 10/100 Mbps operation to increase price/performance options and to support phased conversions
- Full IEEE 802.3 compatibility for existing applications
- Media Independent interface (MII) or 7-wire interface
- Station management (STA) signaling for external physical layer configuration and link negotiation

On-chip CAM (21 addresses)

- Full-duplex mode for doubled bandwidth
- Pause operation hardware support for full-duplex flow control
- Long packet mode for specialized environments
- Short packet mode for fast testing
- PAD generation for ease of processing and reduced processing time

Universal Asynchronous Receiver Transmitter (UART)

- Programmable baud rates
- 32-byte Transmit FIFO and 32-byte Receive FIFO
- UART source clock selectable (Internal clock :PCLK2, External clock: EXT_CLK)
- Auto baud rate detection
- Infra-red (IR) transmit/receive
- Insertion of one or two Stop bits per frame
- Selectable 5-bit, 6-bit, 7-bit, or 8-bit data transfers
- Parity checking

DES/3DES Accelerator

- DES or Triple DES mode
- ECB or CBC mode
- Encryption or decryption support
- General DMA support

1.2 FEATURES (Continue)

General DMA Channels

- Six GDMA channels
- Memory to memory data transfer
- Memory to peripheral data transfer (high-speed UART and DES)
- Support for four external GDMA requests from GDMA request pins (xGDMA_Req0 - xGDMA_Req3).

Six Programmable Timers

- Interval or toggle mode operation

Hardware Watchdog Timer

- Useful for periodic reset or interrupts

Programmable Interrupt Controller

- 28 programmable interrupt sources
- 22 internal sources and 6 external sources
- programmable priority control

Programmable I/O port Controller

- 64 programmable I/O ports
- Individually configurable to input, output, or I/O mode for dedicated signals
- 6 external interrupt request
- 4 external GDMA request
- 4 external GDMA acknowledge
- 6 timer outputs
- 7 UART signals

I²C Controller

- Master mode operation only
- Baud rate generator for serial clock

Three PLLs for System, Core and PHY Clock Each

PLL0 for ARM940T

- The Input frequency is 10MHz.
- Provide up to 166MHz output to ARM940T

PLL1 for system clock

- The Input frequency is 10MHz.
- Provide up to 133MHz output to system

PLL2 for PHY

- The input frequency is 10MHz
- Provide 20 MHz or 25MHz output to external PHY chip

Operating Voltage Range

- Internal Power: 1.8 V \pm 5 %
- I/O Power: 3.3 V \pm 5 %

Operating temperature range

- -40 °C – 85 °C

Package Type

- 272 BGA

1.3 BLOCK DIAGRAM

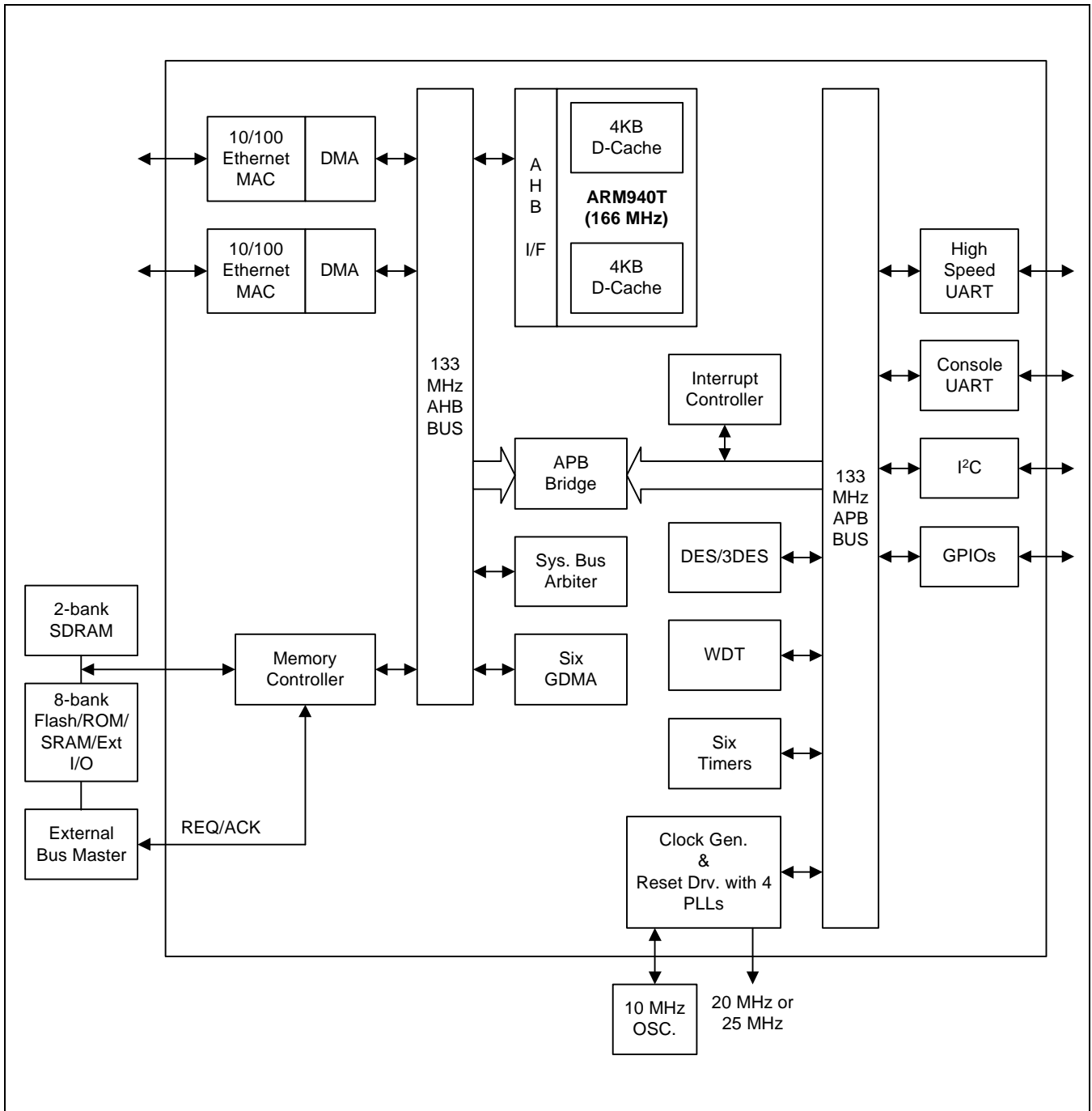

Figure 1-1. S3C2501X Block Diagram

1.4 PACKAGE DIAGRAM

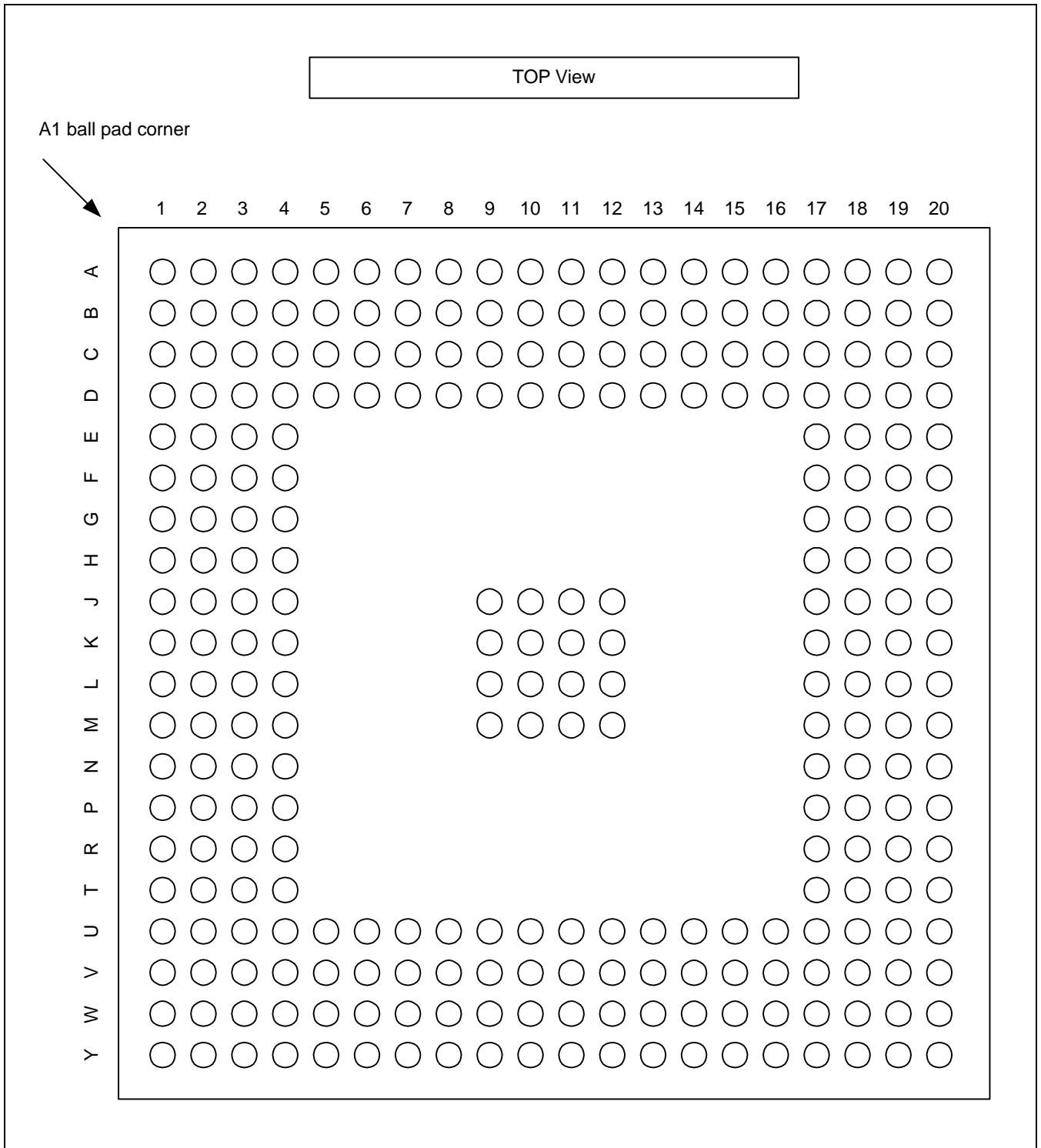

Figure 1-2. S3C2501X Pin Assignment Diagram

1.5 PIN ASSIGNMENT

Pin #	Pin Name	Direction	Pin #	Pin Name	Direction
A1	GND		B11	ADDR17	O
A2	PHY_FREQ	I	B12	ADDR15	O
A3	GPIO59	I/O	B13	ADDR11	O
A4	GPIO56	I/O	B14	ADDR8	O
A5	GPIO52	I/O	B15	ADDR5	O
A6	GPIO49	I/O	B16	ADDR1	O
A7	GPIO47	I/O	B17	XDATA27	I/O
A8	GPIO44	I/O	B18	XDATA26	I/O
A9	N.C		B19	XDATA23	I/O
A10	ADDR20	O	B20	XDATA21	I/O
A11	ADDR19	O	C1	TXD0_0/TXD_10M	O
A12	ADDR16	O	C2	MDC_0	O
A13	ADDR12	O	C3	PHY_CLKO	O
A14	ADDR9	O	C4	GPIO61	I/O
A15	ADDR6	O	C5	GPIO57	I/O
A16	ADDR2	O	C6	GPIO54	I/O
A17	XDATA31	I/O	C7	GPIO50	I/O
A18	XDATA30	I/O	C8	GPIO46	I/O
A19	XDATA25	I/O	C9	GPIO42	I/O
A20	XDATA24	I/O	C10	ADDR22	O
B1	PHY_CLKSEL	I	C11	ADDR18	O
B2	GPIO63	I/O	C12	ADDR14	O
B3	GPIO62	I/O	C13	ADDR10/AP	O
B4	GPIO58	I/O	C14	ADDR7	O
B5	GPIO55	I/O	C15	ADDR3	O
B6	GPIO51	I/O	C16	ADDR0	O
B7	GPIO48	I/O	C17	XDATA28	I/O
B8	GPIO45	I/O	C18	XDATA22	I/O
B9	N.C		C19	XDATA20	I/O
B10	ADDR21	O	C20	XDATA17	I/O

1.5 PIN ASSIGNMENT (Continue)

Pin #	Pin Name	Direction	Pin #	Pin Name	Direction
D1	TXD0_1/LOOP10M	O	E19	XDATA13	I/O
D2	MDIO_0	I/O	E20	XDATA10	I/O
D3	COL_0	I	F1	RXD0_0/RXD_10M	I
D4	GND		F2	RX_CLK_0	I
D5	GPIO60	I/O	F3	TX_ERR_0/PCOMP_10M	O
D6	VDD1.8		F4	VDD1.8	
D7	GPIO53	I/O	F17	VDD3.3	
D8	GND		F18	XDATA12	I/O
D9	GPIO43	I/O	F19	XDATA9	I/O
D10	ADDR23/ALE	O	F20	XDATA7	I/O
D11	VDD1.8		G1	RXD0_2	I
D12	ADDR13	O	G2	RXD0_1	I
D13	GND		G3	VDD3.3	
D14	ADDR4	O	G4	CRS_0	I
D15	VDD1.8		G17	XDATA11	I/O
D16	XDATA29	I/O	G18	XDATA8	I/O
D17	GND		G19	XDATA6	I/O
D18	XDATA19	I/O	G20	XDATA5	I/O
D19	XDATA16	I/O	H1	RX_ERR_0	I
D20	XDATA14	I/O	H2	RX_DV_0/LINK_10M	I
E1	TX_EN_0	O	H3	RXD0_3	I
E2	TXD0_3	O	H4	GND	
E3	TXD0_2	O	H17	GND	
E4	TX_CLK_0	I	H18	XDATA4	I/O
E17	XDATA18	I/O	H19	XDATA3	I/O
E18	XDATA15	I/O	H20	XDATA2	I/O

1.5 PIN ASSIGNMENT (Continue)

Pin #	Pin Name	Direction	Pin #	Pin Name	Direction
J1	VDD1.8_A		L1	VDD1.8_A	
J2	N.C		L2	VDD1.8	
J3	N.C		L3	CPU_FILTER	O
J4	N.C		L4	GND_A	
J9	GND		L9	GND	
J10	GND		L10	GND	
J11	GND		L11	GND	
J12	GND		L12	GND	
J17	XDATA1	I/O	L17	VDD3.3	
J18	XDATA0	I/O	L18	nWBE1/nBE1/DQM1	O
J19	nSDCAS	O	L19	nWBE0/nBE0/DQM0	O
J20	nSDRAS	O	L20	nWBE2/nBE2/DQM2	O
K1	GND_A		M1	VDD1.8_A	
K2	VDD1.8		M2	VDD1.8	
K3	BUS_FILTER	O	M3	PHY_FILTER	O
K4	VDD1.8		M4	GND_A	
K9	GND		M9	GND	
K10	GND		M10	GND	
K11	GND		M11	GND	
K12	GND		M12	GND	
K17	nSDCS1	O	M17	nRCS5	O
K18	nSDCS0	O	M18	nRCS6	O
K19	nSDWE/nWE16	O	M19	nRCS7	O
K20	nWBE3/nBE3/DQM3	O	M20	nOE	O

1.5 PIN ASSIGNMENT (Continue)

Pin #	Pin Name	Direction	Pin #	Pin Name	Direction
N1	VDD1.8_A		T3	TX_ERR_1/PCOMP_10M	O
N2	VDD1.8		T4	RXD1_0/RXD_10M	I
N3	N.C		T17	BUS_FREQ2	I
N4	GND		T18	CPU_FREQ2	I
N17	GND		T19	XBMREQ	I
N18	nRCS2	O	T20	XBMACK	O
N19	nRCS3	O	U1	TX_EN_1	O
N20	nRCS4	O	U2	CRS_1	I
P1	GND_A		U3	RXD1_1	I
P2	MDC_1	O	U4	GND	
P3	COL_1	I	U5	N.C	
P4	TXD1_1/LOOP_10M	O	U6	VDD3.3	
P17	B0SIZE1	I	U7	HURXD/GPIO35	I/O
P18	CKE	O	U8	GND	
P19	nRCS0	O	U9	GPIO0	I/O
P20	nRCS1	O	U10	VDD3.3	
R1	MDIO_1	I/O	U11	xINT2/ GPIO10	I/O
R2	TX_CLK_1	I	U12	xGDMA_Req0/ GPIO14	I/O
R3	TXD1_2	O	U13	GND	
R4	VDD1.8		U14	TIMER2/ GPIO24	I/O
R17	VDD3.3		U15	VDD3.3	
R18	B0SIZE0	I	U16	TMODE	I
R19	nEWAIT	I	U17	GND	
R20	BIG	I	U18	BUS_FREQ1	I
T1	TXD1_0/TXD_10M	O	U19	BUS_FREQ0	I
T2	TXD1_3	O	U20	CPU_FREQ1	I

1.5 PIN ASSIGNMENT (Continue)

Pin #	Pin Name	Direction	Pin #	Pin Name	Direction
V1	RX_CLK_1	I	W1	RXD1_3	I
V2	RXD1_2	I	W2	RX_ERR_1	I
V3	RX_DV_1/LINK10M	I	W3	CUTXD	O
V4	GPIO29	I/O	W4	GPIO28	I/O
V5	UCLK	I	W5	GPIO32	I/O
V6	GPIO34	I/O	W6	XCLK	I
V7	HUnDTR/GPIO37	I/O	W7	HUnDSR/GPIO38	I/O
V8	HUnCTS/GPIO40	I/O	W8	HUnDCD/GPIO41	I/O
V9	GPIO1	I/O	W9	GPIO2	I/O
V10	GPIO5	I/O	W10	GPIO4	I/O
V11	xINT1/GPIO9	I/O	W11	xINT0/GPIO8	I/O
V12	xINT5/GPIO13	I/O	W12	xINT4/GPIO12	I/O
V13	xGDMA_Req3/GPIO17	I/O	W13	xGDMA_Req2/GPIO16	I/O
V14	xGDMA_Ack3/GPIO21	I/O	W14	xGDMA_Ack1/GPIO19	I/O
V15	TIMER3/GPIO25	I/O	W15	TIMER0/GPIO22	I/O
V16	TIMER5/GPIO27	I/O	W16	TIMER4/GPIO26	I/O
V17	nRESET	I	W17	SCL	I/O
V18	TDI	I	W18	TCK	I
V19	CLKMOD1	I	W19	TDO	O
V20	CPU_FREQ0	I	W20	CLKMOD0	I

1.5 PIN ASSIGNMENT (Continue)

Pin #	Pin Name	Direction	Pin #	Pin Name	Direction
Y1	CURXD	I	Y11	GPIO7	I/O
Y2	CLKSEL	I	Y12	xINT3/GPIO11	I/O
Y3	GPIO30	I/O	Y13	xGDMA_Req1/GPIO15	I/O
Y4	GPIO31	I/O	Y14	xGDMA_Ack0/GPIO18	I/O
Y5	GPIO33	I/O	Y15	xGDMA_Ack2/GPIO20	I/O
Y6	HUTXD/GPIO36	I/O	Y16	TIMER1/GPIO23	I/O
Y7	HUnRTS/GPIO39	I/O	Y17	GND	
Y8	HCLKO	O	Y18	SDA	I/O
Y9	GPIO3	I/O	Y19	TMS	I
Y10	GPIO6	I/O	Y20	nTRST	I

1.6 SIGNAL DESCRIPTION

Table 1-1. S3C2501X Signal Descriptions

Group	Pin Name	Pin	Type	Pad Type	Description
System Config (20)	XCLK	1	I	Phic	S3C2501X PLL Clock Source. If CLKSEL is Low, PLL output clock is used as the system clock. If CLKSEL is high, XCLK is used as the system clock.
	HCLKO	1	O	phbst24	System clock output. The internal system clock is monitored via HCLKO. If SDRAM is used, this clock should be used SDRAM clock.
	CLKSEL	1	I	Phic	Clock Select for CPU PLL and system PLL. If CLKSEL is low, CPU PLL clock is used as ARM940T source clock and system PLL clock is used system clock source, depending on CLKMOD[1:0]. If CLKSEL is high, XCLK is used both clock sources.
	BUS_FILTER	1	I	poar50_abb	PLL filter pin for System PLL. If the PLL is used, 320pF capacitor should be connected between the pin and ground.
	PHY_FREQ	1	I	Phic	PHY clock frequency select for PHY PLL. 0 = 20MHz, 1 = 25MHz
	PHY_CLKSEL	1	I	Phic	Clock Select for PHY PLL. If this pin is set to low, the PHY PLL generates clock depending on PHY_FREQ state. The PHY PLL goes into power down mode with PHY_CLKSEL set to high.
	PHY_FILTER	1	O	poar50_abb	PLL filter pin for PHY PLL. If the PLL is used, 320pF capacitor should be connected between the pin and ground.
	PHY_CLKO	1	O	phob8	PHY clock Out. PHY PLL clock output can be monitored by PHY_CLKO. This clock is used as the external phy source clock.
	CPU_FILTER	1	O	poar50_abb	PLL filter pin for System PLL. If the PLL is used, 320pF capacitor should be connected between the pin and ground.

Table 1-1. S3C2501X Signal Descriptions (Continue)

Group	Pin Name	Pin	Type	Pad Type	Description
System Config (20)	CLKMOD [1:0]	2	I	Phic	The CLKMOD pin determines internal clock scheme of S3C2501X. When CLKMOD is "00", the nfast clock mode is defined. In this mode, the same clock is used as CPU clock and system clock. When CLKMOD is "10", the sync mode is defined. In this mode, the system clock is half frequency of the CPU clock. When CLKMOD is "11", the async clock mode is defined. In this mode, the CPU clock and system clock can operate independently as long as the CPU clock is faster than system clock.
	CPU_FREQ [2:0]	3	I	phic	CPU Clock Frequency Selection.
	BUS_FREQ [2:0]	3	I	phic	System Bus Clock Frequency Selection.
	nRESET	1	I	phis	Not Reset. NRESET is the global reset input for the S3C2501X and nRESET must be held to "low" for at least 64 clock cycles for digital filtering.
	TMODE	1	I	phicd	Test Mode. The TMODE pin setting is interpreted as follows: 0 = normal operating mode 1 = chip test mode.
	BIG	1	I	phicd	BIG endian mode select pin When this pin is set to "0", the S3C2501X operates in little endian mode. When this pin is set to "1", the S3C2501X operates in big endian mode.

Table 1-1. S3C2501X Signal Descriptions (Continue)

Group	Pin Name	Pin	Type	Pad Type	Description
Memory Interface (80)	ADDR[23:0] ADDR[10]/AP	24	O	Phot20	Address bus. The 24-bit address bus covers the full 16 M word address range of each ROM/SRAM /FLASH and external I/O bank. In the SDRAM interface, ADDR[14:13] is always used as bank address of SDRAM devices. If SDRAM devices with 2 internal bank is used, ADDR[13] should be connected to the BA of SDRAM. If SDRAM devices with 4 internal bank is used, ADDR[14:13] should be connected to the BA[1:0] of SDRAM. ADDR[10]/AP is the auto precharge control pin. The auto precharge command is issued at the same time as burst read or burst write by asserting high on ADDR[10]/AP.
	XDATA[31:0]	32	I/O	phbsut20	External bi-directional 32bit data bus. The S3C2501X supports 8 bit, 16bit, 32bit bus with ROM/SRAM/Flash/Ext IO bank, but supports 16 bit or 32 bit bus with SDRAM bank.
	nSDCS[1:0]	2	O	phot20	Not chip select strobe for SDRAM. Two SDRAM banks are supported.
	nSDRAS	1	O	phot20	Not row address strobe for SDRAM. NSDRAS signal is used for both SDRAM banks.
	nSDCAS	1	O	phot20	Not column address strobe for SDRAM. NSDCAS signal is used for both SDRAM banks.
	CKE	1	O	phob12	Clock Enable for SDRAM CKE is clock enable signal for SDRAM.
	nSDWE/nWE16	1	O	phot20	Not Write Enable for SDRAM or 16 bit ROM/SRAM. This signal is always used as write enable of SDRAM and is used as write enable of only 16-bit ROM/SRAM/Flash. (That is, It is not enabled for 8 bit Memory)

Table 1-1. S3C2501X Signal Descriptions (Continue)

Group	Pin Name	Pin	Type	Pad Type	Description
Memory Interface (80)	nEWAIT	1	I	phicu	Not External wait signal. This signal is activated when an external I/O device or ROM/SRAM/Flash banks need more access cycles than those defined in the corresponding control register.
	nRCS[7:0]	8	O	phot20	Not ROM/SRAM/Flash/ External I/O Chip select. The S3C2501X supports up to 8 banks of ROM/SRAM/Flash/ External I/O. By controlling the nRCS signals, you can map CPU address into the physical memory banks.
	B0SIZE[1:0]	2	I	phic	Bank 0 Data Bus Access Size. Bank0 is used for the boot program. You use these pins to set the size of the bank 0 data bus as follows: "01" = Byte, "10" = Half word, "11" = Word, and "00" = reserved.
	nOE	1	O	phot20	Not output enable. Whenever a memory read access occurs, the nOE output controls the output enable port of the specific memory device.
	nWBE[3:0]/ nBE[3:0]/ DQM[3:0]	4	O	phot20	Not write byte enable or DQM for SDRAM Whenever a memory write access occurs, the nWBE output controls the write enable port of the specific memory device. DQM is data input/output mask signal for SDRAM.

Table 1-1. S3C2501X Signal Descriptions (Continue)

Group	Pin Name	Pin	Type	Pad Type	Description
Memory Interface (80)	XBMREQ	1	I	phicd	External Master bus request. An external bus master uses this pin to request the external bus. When it activates the XBMREQ, the S3C2501X drives the state of external bus pins to high impedance. This lets the external bus master take control of the external bus. When it has control, the external bus master assumes responsibility for SDRAM refresh operation. The XBMREQ is deactivated when the external bus master releases the external bus. When this occurs, the S3C2501X can get the control of the bus and the XBMACK goes "low".
	XBMACK	1	O	phob8	External bus Acknowledge.
TAP Control (5)	TCK	1	I	phic	JTAG Test Clock. The JTAG test clock shifts state information and test data into, and out of, the S3C2501X during JTAG test operations.
	TMS	1	I	phicu	JTAG Test Mode Select. This pin controls JTAG test operations in the S3C2501X. This pin is internally connected pull-up.
	TDI	1	I	phicu	JTAG Test Data In. The TDI level is used to serially shift test data and instructions into the S3C2501X during JTAG test operations. This pin is internally connected pull-up.
	TDO	1	O	phot12	JTAG Test Data Out. The TDO level is used to serially shift test data and instructions out of the S3C2501X during JTAG test operations.
	nTRST	1	I	phicu	JTAG Not Reset. Asynchronous reset of the JTAG logic. This pin is internally connected pull-up.

Table 1-1. S3C2501X Signal Descriptions (Continue)

Group	Pin Name	Pin	Type	Pad Type	Description
Ethernet Controller0 (18)	MDC_0	1	O	phob12	Management Data Clock. The signal level at the MDC pin is used as a timing reference for data transfers that are controlled by the MDIO signal.
	MDIO_0	1	I/O	phbcut12	Management Data I/O. When a read command is being executed, data that is clocked out of the PHY is presented on this pin. When a write command is being executed, data that is clocked out of the controller is presented on this pin for the Physical Layer Entity, PHY.
	COL_0	1	I	phis	Collision Detected/Collision Detected for 10M. COL is asserted asynchronously with minimum delay from the start of a collision on the medium in MII mode. COL_10M is asserted when a 10-Mbit/s PHY detects a collision.
	TX_CLK_0	1	I	phis	Transmit Clock/Transmit Clock for 10M. The controller drives TXD[3:0] and TX_EN from the rising edge of TX_CLK. In MII mode, the PHY samples TXD[3:0] and TX_EN on the rising edge of TX_CLK. For data transfers, TXCLK_10M is provided by the 10M-bit/s PHY.
	TXD0[3:0]/ TXD_10M/ LOOP_10M	4	O	phob12	Transmit Data/Transmit Data for 10M. Transmit data is aligned on nibble boundaries. TXD[0] corresponds to the first bit to be transmitted on the physical medium, which is the LSB of the first byte and the fifth bit of that byte during the next clock. TXD_10M is shared with TXD[0] and is a data line for transmitting to the 10M-bit/s PHY. LOOP_10M is shared with TXD[1] and is driven by the loop-back bit in the control register.

Table 1-1. S3C2501X Signal Descriptions (Continue)

Group	Pin Name	Pin	Type	Pad Type	Description
Ethernet Controller0 (18)	TX_EN_0	1	O	phob4	Transmit Enable/Transmit Enable for 10M. TX_EN provides precise framing for the data carried on TXD[3:0]. This pin is active during the clock periods in which TXD[3:0] contains valid data to be transmitted from the preamble stage through CRC. When the controller is ready to transfer data, it asserts TXEN_10M.
	TX_ERR_0/ PCOMP_10M	1	O	phob4	Transmit Error/Packet Compression Enable for 10M. TX_ERR is driven synchronously to TX_CLK and sampled continuously by the Physical Layer Entity, PHY. If asserted for one or more TX_CLK periods, TX_ERR causes the PHY to emit one or more symbols which are not part of the valid data, or delimiter set located somewhere in the frame that is being transmitted. PCOMP_10M is asserted immediately after the packet's DA field is received. PCOMP_10M is used with the Management Bus of the DP83950 Repeater Interface Controller (from National Semiconductor). The MAC can be programmed to assert PCOMP if there is a CAM match, or if there is not a match. The RIC (Repeater Interface Controller) uses this signal to compress (shorten) the packet received for management purposes and to reduce memory usage. (See the DP83950 Data Sheet, published by National Semiconductor, for details on the RIC Management Bus.) This pin is controlled by a special register, with which you can define the polarity and assertion method (CAM match active or not match active) of the PCOMP signal.

Table 1-1. S3C2501X Signal Descriptions (Continue)

Group	Pin Name	Pin	Type	Pad Type	Description
Ethernet Controller0 (18)	CRS_0	1	I	phis	Carrier Sense/Carrier Sense for 10M. CRS is asserted asynchronously with minimum delay from the detection of a non-idle medium in MII mode. CRS_10M is asserted when a 10-Mbit/s PHY has data to transfer. A 10-Mbit/s transmission also uses this signal.
	RX_CLK_0	1	I	phis	Receive Clock/Receive Clock for 10M. RX_CLK is a continuous clock signal. Its frequency is 25 MHz for 100-Mbit/s operation, and 2.5 MHz for 10-Mbit/s. RXD[3:0], RX_DV, and RX_ERR are driven by the PHY off the falling edge of RX_CLK, and sampled on the rising edge of RX_CLK. To receive data, the RXCLK_10 M clock comes from the 10Mbit/s PHY.
	RXD0[3:0]/RXD_10M	4	I	phis	Receive Data/Receive Data for 10M. RXD is aligned on nibble boundaries. RXD[0] corresponds to the first bit received on the physical medium, which is the LSB of the byte in one clock period and the fifth bit of that byte in the next clock. RXD_10M is shared with RXD[0] and it is a line for receiving data from the 10-Mbit/s PHY.
	RX_DV_0/ LINK_10M	1	I	phis	Receive Data Valid. PHY asserts RX_DV synchronously, holding it active during the clock periods in which RXD[3:0] contains valid data received. PHY asserts RX_DV no later than the clock period when it places the first nibble of the start frame delimiter (SFD) on RXD[3:0]. If PHY asserts RX_DV prior to the first nibble of the SFD, then RXD[3:0] carries valid preamble symbols. LINK_10M is shared with RX_DV and used to convey the link status of the 10-Mbit/s endec. The value is stored in a status register.

Table 1-1. S3C2501X Signal Descriptions (Continue)

Group	Pin Name	Pin	Type	Pad Type	Description
Ethernet Controller0 (18)	RX_ERR_0	1	I	phisd	Receive Error. PHY asserts RX_ERR synchronously whenever it detects a physical medium error (e.g., a coding violation). PHY asserts RX_ERR only when it asserts RX_DV.
Ethernet Controller1 (18)	MDC_1	1	O	phob12	Management Data Clock. The signal level at the MDC pin is used as a timing reference for data transfers that are controlled by the MDIO signal.
	MDIO_1	1	I/O	phbcut12	Management Data I/O. When a read command is being executed, data that is clocked out of the PHY is presented on this pin. When a write command is being executed, data that is clocked out of the controller is presented on this pin for the Physical Layer Entity, PHY.
	COL_1	1	I	phis	Collision Detected/Collision Detected for 10M. COL is asserted asynchronously with minimum delay from the start of a collision on the medium in MII mode. COL_10M is asserted when a 10-Mbit/s PHY detects a collision.
	TX_CLK_1	1	I	phis	Transmit Clock/Transmit Clock for 10M. The controller drives TXD[3:0] and TX_EN from the rising edge of TX_CLK. In MII mode, the PHY samples TXD[3:0] and TX_EN on the rising edge of TX_CLK. For data transfers, TXCLK_10M is provided by the 10-Mbit/s PHY.

Table 1-1. S3C2501X Signal Descriptions (Continue)

Group	Pin Name	Pin	Type	Pad Type	Description
Ethernet Controller1 (18)	TXD1[3:0]/ TXD_10M/ LOOP_10M	4	O	phob12	Transmit Data/Transmit Data for 10M. Transmit data is aligned on nibble boundaries. TXD[0] corresponds to the first bit to be transmitted on the physical medium, which is the LSB of the first byte and the fifth bit of that byte during the next clock. TXD_10M is shared with TXD[0] and is a data line for transmitting to the 10-Mbit/s PHY. LOOP_10M is shared with TXD[1] and is driven by the loop-back bit in the control register.
	TX_EN_1	1	O	phob4	Transmit Enable/Transmit Enable for 10M. TX_EN provides precise framing for the data carried on TXD[3:0]. This pin is active during the clock periods in which TXD[3:0] contains valid data to be transmitted from the preamble stage through CRC. When the controller is ready to transfer data, it asserts TXEN_10M.

Table 1-1. S3C2501X Signal Descriptions (Continue)

Group	Pin Name	Pin	Type	Pad Type	Description
Ethernet Controller1 (18)	TX_ERR_1/ PCOMP_10M	1	O	phob4	Transmit Error/Packet Compression Enable for 10M. TX_ERR is driven synchronously to TX_CLK and sampled continuously by the Physical Layer Entity, PHY. If asserted for one or more TX_CLK periods, TX_ERR causes the PHY to emit one or more symbols which are not part of the valid data, or delimiter set located somewhere in the frame that is being transmitted. PCOMP_10M is asserted immediately after the packet's DA field is received. PCOMP_10M is used with the Management Bus of the DP83950 Repeater Interface Controller (from National Semiconductor). The MAC can be programmed to assert PCOMP if there is a CAM match, or if there is not a match. The RIC (Repeater Interface Controller) uses this signal to compress (shorten) the packet received for management purposes and to reduce memory usage. (See the DP83950 Data Sheet, published by National Semiconductor, for details on the RIC Management Bus.) This pin is controlled by a special register, with which you can define the polarity and assertion method (CAM match active or not match active) of the PCOMP signal.
	CRS_1	1	I	phis	Carrier Sense/Carrier Sense for 10M. CRS is asserted asynchronously with minimum delay from the detection of a non-idle medium in MII mode. CRS_10M is asserted when a 10-Mbit/s PHY has data to transfer. A 10-Mbit/s transmission also uses this signal.

Table 1-1. S3C2501X Signal Descriptions (Continue)

Group	Pin Name	Pin	Type	Pad Type	Description
Ethernet Controller1 (18)	RX_CLK_1	1	I	phis	Receive Clock/Receive Clock for 10M. RX_CLK is a continuous clock signal. Its frequency is 25 MHz for 100-Mbit/s operation, and 2.5 MHz for 10-Mbit/s. RXD[3:0], RX_DV, and RX_ERR are driven by the PHY off the falling edge of RX_CLK, and sampled on the rising edge of RX_CLK. To receive data, the RXCLK_10 M clock comes from the 10Mbit/s PHY.
	RXD1[3:0]/RXD_10M	4	I	phis	Receive Data/Receive Data for 10M. RXD is aligned on nibble boundaries. RXD[0] corresponds to the first bit received on the physical medium, which is the LSB of the byte in one clock period and the fifth bit of that byte in the next clock. RXD_10M is shared with RXD[0] and it is a line for receiving data from the 10-Mbit/s PHY.
	RX_DV_1 LINK_10M	1	I	phis	Receive Data Valid. PHY asserts RX_DV synchronously, holding it active during the clock periods in which RXD[3:0] contains valid data received. PHY asserts RX_DV no later than the clock period when it places the first nibble of the start frame delimiter (SFD) on RXD[3:0]. If PHY asserts RX_DV prior to the first nibble of the SFD, then RXD[3:0] carries valid preamble symbols. LINK_10M is shared with RX_DV and used to convey the link status of the 10-Mbit/s endec. The value is stored in a status register.
	RX_ERR_1	1	I	phisd	Receive Error. PHY asserts RX_ERR synchronously whenever it detects a physical medium error (e.g., a coding violation). PHY asserts RX_ERR only when it asserts RX_DV.

Table 1-1. S3C2501X Signal Descriptions (Continue)

Group	Pin Name	Pin	Type	Pad Type	Description
CUART (2)	CURXD	1	I	phis	Console UART Receive Data.
	CUTXD	1	O	phob8	Console UART Transmit Data.
HUART (7)	UCLK	1	I	Phis	HUART External Clock
	HURXD/GPIO35	1	I/O	phbst8	HUART Receive Data. HURXD is the HUART input signal for receiving serial data. General I/O Port
	HUTXD/GPIO36	1	I/O	phbst8	HUART Transmit Data. HUTXD is the HUART output signal for transmitting serial data. General I/O Port
	HUnDTR/GPIO37	1	I/O	phbst8	Not HUART Data Terminal Ready.. This output signals the host (or peripheral) that HUART is ready to transmit or receive serial data. General I/O Port
	HUnDSR/GPIO38	1	I/O	phbst8	Not HUART Data Set Ready. This input signals in the HUART that the peripheral (or host) is ready to transmit or receive serial data General I/O Port
	HUnRTS/GPIO39	1	I/O	phbst8	Not request to send. This pin output state goes Low or High according to the transmit data is in Tx buffer or Tx FIFO when hardware flow control bit value set to one in HUART control register. If Tx buffer or Tx FIFO has data to send, this pin state goes low. If hardware flow control bit is zero, this pin output can be controlled directly by HUART control register. General I/O Port

Table 1-1. S3C2501X Signal Descriptions (Continue)

Group	Pin Name	Pin	Type	Pad Type	Description
HUART (7)	HUnCTS/GPIO40	1	I/O	phbst8	Not Clear to send This input pin function controlled by hardware flow control bit value in HUART control register. If hardware flow control bit set to one, HUART can transmit the transmitting data only when this pin state is active. General I/O Port
	HUnDCD/GPIO41	1	I/O	phbst8	Not Data Carrier Detect. This input pin function is determined by hardware flow control bit value in HUART control register. If hardware flow control bit set to one, HUART can receive the receiving data only when this pin state is active. General I/O Port
GPIO Included xINT xGDMA_ Req xGDMA_ _Ack Timer	GPIO[7:0]	8	I/O	phbst8	General I/O Ports
	GPIO[34:28]	7	I/O	phbst8	General I/O Ports
	GPIO[63:42]	22	I/O	phbst8	General I/O Ports
	xINT[5:0]/ GPIO[13:8]	6	I/O	phbst8	External interrupt requests/General I/O Ports.
	xGDMA_Req [3:0] /GPIO[17:14]	4	I/O	phbst8	External DMA requests for GDMA/General I/O Ports.
	xGDMA_Ack [3:0] /GPIO[21:18]	4	I/O	phbst8	External DMA acknowledge from GDMA/General I/O Ports.
	TIMER0/GPIO[22]	1	I/O	phbst8	TIMER0 Out/General I/O Port.
	TIMER1/GPIO[23]	1	I/O	phbst8	TIMER1 Out/General I/O Port.
	TIMER2/GPIO[24]	1	I/O	phbst8	TIMER2 Out/General I/O Port.
	TIMER3/GPIO[25]	1	I/O	phbst8	TIMER3 Out/General I/O Port.
	TIMER4/GPIO[26]	1	I/O	phbst8	TIMER4 Out/General I/O Port.
TIMER5/GPIO[27]	1	I/O	phbst8	TIMER5 Out/General I/O Port.	
I ² C (2)	SCL	1	I/O	phbcd8	I ² C serial clock.
	SDA	1	I/O	phbcd8	I ² C serial data.

NOTE: Total Number of Signal Pins = 210

1.7 PAD TYPE

Table 1-2. S3C2501X Pad Type and Feature

PAD Type	Type	Current Drive	Cell Type	Feature	Slew Rate Control
Phic	I	–	LVC MOS Level	3.3V	–
Phicd	I	–	LVC MOS Level	3.3V	–
Phicu	I	–	LVC MOS Level	3.3V Pull-up resistor	–
Phis	I	–	LVC MOS Schmitt Trigger	3.3V	–
Phisd	I	–	LVC MOS Schmitt Trigger	3.3V Pull-down resistor	–
Poar50_abb	O	–	Analog output with seperate bulk bias		–
phob4	O	4mA	Normal Buffer		
Phob12	O	12mA	Normal Buffer		
Phot12	O	12mA	Tri-State Buffer		–
phot20	O	20mA	Tri-State Buffer		–
Phbcut12	I/O	12mA	LVC MOS Level Tri-State Buffer	3.3V Pull-up resistor	–
phbsud4	I/O	4sm	LVC MOS Schmit trigger level Tri-State Buffer	3.3 Pull-up resistor	
phbst8	I/O	8mA	LVC MOS Schmit trigger level Tri-State Buffer	3.3V	
phbst16	I/O	16mA	LVC MOS Schmit trigger leve Tri-State Buffer	3.3V	
Phbst24	I/O	24mA	LVC MOS Schmit trigger level Tri-State Buffer	3.3V	
Phbsut20	I/O	20mA	LVC MOS Schmit trigger level Tri-State Buffer	3.3V Pull-up resistor	
phbcd8	I/O	8mA	LVC MOS Level Open drain buffer	3.3V	–
Pbusbfs	I/O	6mA	USB Buffer		–

NOTE: For the detail information about the pad type. Input/Output Cells of the STD130/MDL130 0.18µm 3.3V Standard Cell Library Data Book” which is produced by Samsung Electronics Co., Ltd, ASIC Team.

1.8 SPECIAL REGISTERS

Table 1-3. S3C2501X System Configuration

Registers	Address	R/W	Description	Reset Value
SYSCFG	0xF0000000	R/W	System configuration register	–
PDCODE	0xF0000004	R	Product code and revision number register	0x25010000
CLKCON	0xF0000008	R/W	System clock control register	0x00000000
PCLKDIS	0xF000000C	R/W	Peripheral clock disable register	0xF0005000
CLKST	0xF0000010	R	Clock Status register	
HPRIF	0xF0000014	R/W	AHB bus master fixed priority register	0x00543210
HPRIR	0xF0000018	R/W	AHB bus master round-robin priority register	0x00000000
CPLL	0xF000001C	R/W	Core PLL Configuration Register	0x0001039E
SPLL	0xF0000020	R/W	System BUS PLL Configuration Register	0x00010370
PPLL	0xF0000028	R/W	PHY PLL Configuration Register	0x000103111

Table 1-4. S3C2501X Memory Controller

Registers	Address	R/W	Description	Reset Value
B0CON	0xF0010000	R/W	Bank 0 control register	0xC514E488
B1CON	0xF0010004	R/W	Bank 1 control register	0xC514E488
B2CON	0xF0010008	R/W	Bank 2 control register	0xC514E488
B3CON	0xF001000C	R/W	Bank 3 control register	0xC514E488
B4CON	0xF0010010	R/W	Bank 4 control register	0xC514E488
B5CON	0xF0010014	R/W	Bank 5 control register	0xC514E488
B6CON	0xF0010018	R/W	Bank 6 control register	0xC514E488
B7CON	0xF001001C	R/W	Bank 7 control register	0xC514E488
MUXBCON	0xF0010020	R/W	Muxed bus control register	0x006DB6DB
WAITCON	0xF0010024	R/W	Wait control register	0x00000000

Table 1-5. S3C2501X SDRAM Controller

Registers	Address	R/W	Description	Reset Value
CFGREG	0xF0020000	R/W	SDRAM Configuration register	0x00099F0C
CMDREG	0xF0020004	R/W	SDRAM Command register	0x00000000
REFREG	0xF0020008	R/W	Refresh timer register	0x00000020
WBTOREG	0xF002000C	R/W	Write buffer time-out register	0x00000000

Table 1-6. S3C2501X IIC Controller

Registers	Address	R/W	Description	Reset Value
IICCON	0xF00F0000	R/W	Control status register	0x00000000
IICBUF	0xF00F0004	R/W	Shift buffer register	Undefined
IICPS	0xF00F0008	R/W	Prescaler register	0x00000000
IICCNT	0xF00F000C	R/W	Prescaler counter register	0x00000000
IICPND	0xF00F0010	R/W	Interrupt pending register	0x00000000

Table 1-7. S3C2501X Ethernet Controller 0

Registers	Address	R/W	Description	Reset Value
BDMATXCONA	0xF00A0000	R/W	Buffered DMA transmit control register	0x00000000
BDMARXCONA	0xF00A0004	R/W	Buffered DMA receive control register	0x00000000
BDMATXDPTRA	0xF00A0008	R/W	Transmit buffer descriptor start address	0x00000000
BDMARXDPTRA	0xF00A000C	R/W	Receive buffer descriptor start address	0x00000000
BTXBDCNTA	0xF00A0010	R/W	BDMA Tx buffer descriptor counter	0x00000000
BRXBDCNTA	0xF00A0014	R/W	BDMA Rx buffer descriptor counter	0x00000000
BMTXINTENA	0xF00A0018	R/W	BDMA/MAC Tx Interrupt enable register	0x00000000
BMRXINTENA	0xF00A001C	R/W	BDMA/MAC Rx Interrupt enable register	0x00000000
BMTXSTATA	0xF00A0020	R/W	BDMA/MAC Tx Status register	0x00000000
BMRXSTATA	0xF00A0024	R/W	BDMA/MAC Rx Status register	0x00000000
BDMARXLENA	0xF00A0028	R/W	Receive Frame Size	0x00000000
CFTXSTATA	0xF00A0030	R	Transmit control frame status	0x00000000
MACCONA	0xF00B0000	R/W	MAC control	0x00000000
CAMCONA	0xF00B0004	R/W	CAM control	0x00000000
MACTXCONA	0xF00B0008	R/W	Transmit control	0x00000000
MACTXSTATA	0xF00B000C	R/W	Transmit status	0x00000000
MACRXCONA	0xF00B0010	R/W	Receive control	0x00000000
MACRXSTATA	0xF00B0014	R/W	Receive status	0x00000000
STADATAA	0xF00B0018	R/W	Station management data	0x00000000
STACONA	0xF00B001C	R/W	Station management control and address	0x00006000
CAMENA	0xF00B0028	R/W	CAM enable	0x00000000
MISSCNTA	0xF00B003C	R(Clr)/W	Missed error count	0x00000000
PZCNTA	0xF00B0040	R	Pause count	0x00000000
RMPZCNTA	0xF00B0044	R	Remote pause count	0x00000000
CAMA	0xF00B0080- 0xF00B00FC	W	CAM content (32 words)	Undefined

Table 1-8. S3C2501X Ethernet Controller 1

Registers	Address	R/W	Description	Reset Value
BDMATXCONB	0xF00C0000	R/W	Buffered DMA transmit control register	0x00000000
BDMARXCONB	0xF00C0004	R/W	Buffered DMA receive control register	0x00000000
BDMATXDPTRB	0xF00C0008	R/W	Transmit buffer descriptor start address	0x00000000
BDMARXDPTRB	0xF00C000C	R/W	Receive buffer descriptor start address	0x00000000
BTXBDCNTB	0xF00C0010	R/W	BDMA Tx buffer descriptor counter	0x00000000
BRXBDCNTB	0xF00C0014	R/W	BDMA Rx buffer descriptor counter	0x00000000
BMTXINTENB	0xF00C0018	R/W	BDMA/MAC Tx Interrupt enable register	0x00000000
BMRXINTENB	0xF00C001C	R/W	BDMA/MAC Rx Interrupt enable register	0x00000000
BMTXSTATB	0xF00C0020	R/W	BDMA/MAC Tx Status register	0x00000000
BMRXSTATB	0xF00C0024	R/W	BDMA/MAC Rx Status register	0x00000000
BDMARXLENB	0xF00C0028	R/W	Receive Frame Size	0x00000000
CFTXSTATB	0xF00C0030	R	Transmit control frame status	0x00000000
MACCONB	0xF00D0000	R/W	MAC control	0x00000000
CAMCONB	0xF00D0004	R/W	CAM control	0x00000000
MACTXCONB	0xF00D0008	R/W	Transmit control	0x00000000
MACTXSTATB	0xF00D000C	R/W	Transmit status	0x00000000
MACRXCONB	0xF00D0010	R/W	Receive control	0x00000000
MACRXSTATB	0xF00D0014	R/W	Receive status	0x00000000
STADATAB	0xF00D0018	R/W	Station management data	0x00000000
STACONB	0xF00D001C	R/W	Station management control and address	0x00006000
CAMENB	0xF00D0028	R/W	CAM enable	0x00000000
MISSCNTB	0xF00D003C	R(Clr)/W	Missed error count	0x00000000
PZCNTB	0xF00D0040	R	Pause count	0x00000000
RMPZCNTB	0xF00D0044	R	Remote pause count	0x00000000
CAMB	0xF00D0080- 0xF00D00FC	W	CAM content (32 words)	Undefined

Table 1-9. S3C2500 DES Controller

Registers	Address	R/W	Description	Reset Value
DESCON	0xF0090000	R/W	DES/3DES control register	0x00000000
DESSTA	0xF0090004	R	DES/3DES status register	0x00000231
DESINT	0xF0090008	R/W	DES/3DES interrupt enable register	0x00000000
DESRUN	0xF009000C	W	DES/3DES run enable register	0x00000000
DESKEY1L	0xF0090010	R/W	Key 1 left half	0x00000000
DESKEY1R	0xF0090014	R/W	Key 1 right half	0x00000000
DESKEY2L	0xF0090018	R/W	Key 2 left half	0x00000000
DESKEY2R	0xF009001C	R/W	Key 2 right half	0x00000000
DESKEY3L	0xF0090020	R/W	Key 3 left half	0x00000000
DESKEY3R	0xF0090024	R/W	Key 3 right half	0x00000000
DESIVL	0xF0090028	R/W	IV left half	0x00000000
DESIVR	0xF009002C	R/W	IV right half	0x00000000
DESINFIFO	0xF0090030	W	DES/3DES input FIFO	0XXXXXXXXX
DESOUTFIFO	0xF0090034	R	DES/3DES output FIFO	0XXXXXXXXX

Table 1-10. S3C2501X GDMA Controller

Registers	Address	R/W	Description	Reset Value
DPRIC	0xF0051000	R/W	GDMA priority configuration register	0x00000000
DPRIF	0xF0052000	R/W	GDMA programmable priority register for fixed	0x00543210
DPRIR	0xF0053000	R/W	GDMA programmable priority register for round-robin	0x00000000
DCON0	0xF0050000	R/W	GDMA channel 0 control register	0x00000000
DSAR0	0xF0050004	R/W	GDMA channel 0 source address register	0x00000000
DDAR0	0xF0050008	R/W	GDMA channel 0 destination address register	0x00000000
DTCR0	0xF005000C	R/W	GDMA channel 0 transfer count register	0x00000000
DRER0	0xF0050010	W	GDMA channel 0 run enable register	0x00000000
DIPR0	0xF0050014	R/WC	GDMA channel 0 interrupt pending register	0x00000000
DCON1	0xF0050020	R/W	GDMA channel 1 control register	0x00000000
DSAR1	0xF0050024	R/W	GDMA channel 1 source address register	0x00000000
DDAR1	0xF0050028	R/W	GDMA channel 1 destination address register	0x00000000
DTCR1	0xF005002C	R/W	GDMA channel 1 transfer count register	0x00000000
DRER1	0xF0050030	W	GDMA channel 1 run enable register	0x00000000
DIPR1	0xF0050034	R/WC	GDMA channel 1 interrupt pending register	0x00000000
DCON2	0xF0050040	R/W	GDMA channel 2 control register	0x00000000
DSAR2	0xF0050044	R/W	GDMA channel 2 source address register	0x00000000
DDAR2	0xF0050048	R/W	GDMA channel 2 destination address register	0x00000000
DTCR2	0xF005004C	R/W	GDMA channel 2 transfer count register	0x00000000
DRER2	0xF0050050	W	GDMA channel 2 run enable register	0x00000000
DIPR2	0xF0050054	R/WC	GDMA channel 2 interrupt pending register	0x00000000
DCON3	0xF0050060	R/W	GDMA channel 3 control register	0x00000000
DSAR3	0xF0050064	R/W	GDMA channel 3 source address register	0x00000000
DDAR3	0xF0050068	R/W	GDMA channel 3 destination address register	0x00000000
DTCR3	0xF005006C	R/W	GDMA channel 3 transfer count register	0x00000000
DRER3	0xF0050070	W	GDMA channel 3 run enable register	0x00000000
DIPR3	0xF0050074	R/WC	GDMA channel 3 interrupt pending register	0x00000000
DCON4	0xF0050080	R/W	GDMA channel 4 control register	0x00000000
DSAR4	0xF0050084	R/W	GDMA channel 4 source address register	0x00000000
DDAR4	0xF0050088	R/W	GDMA channel 4 destination address register	0x00000000
DTCR4	0xF005008C	R/W	GDMA channel 4 transfer count register	0x00000000
DRER4	0xF0050090	W	GDMA channel 4 run enable register	0x00000000
DIPR4	0xF0050094	R/WC	GDMA channel 4 interrupt pending register	0x00000000
DCON5	0xF00500A0	R/W	GDMA channel 5 control register	0x00000000
DSAR5	0xF00500A4	R/W	GDMA channel 5 source address register	0x00000000
DDAR5	0xF00500A8	R/W	GDMA channel 5 destination address register	0x00000000
DTCR5	0xF00500AC	R/W	GDMA channel 5 transfer count register	0x00000000
DRER5	0xF00500B0	W	GDMA channel 5 run enable register	0x00000000
DIPR5	0xF00500B4	R/WC	GDMA channel 5 interrupt pending register	0x00000000

Table 1-11. S3C2501X Console UART Controller

Register	Address	R/W	Description	Reset Value
CUCON	0xF0060000	R/W	Console UART control register	0x00000000
CUSTAT	0xF0060004	R/W	Console UART status register	0x00060800
CUINT	0xF0060008	R/W	Console UART interrupt enable register	0x00000000
CUTXBUF	0xF006000C	W	Console UART transmit data register	–
CURXBUF	0xF0060010	R	Console UART receive data register	–
CUBRD	0xF0060014	R/W	Console UART baud rate divisor register	0x0000
CUCHAR1	0xF0060018	R/W	Console UART control character register 1	0x00000000
CUCHAR2	0xF006001C	R/W	Console UART control character register 2	0x00000000

Table 1-12. S3C2501X High speed UART Controller

Register	Address	R/W	Description	Reset Value
HUCON	0xF0080000	R/W	High-Speed UART control register	0x00000000
HUSTAT	0xF0080004	R/W	High-Speed UART status register	–
HUINT	0xF0080008	R/W	High-Speed UART interrupt enable register	0x00000000
HUTXBUF	0xF008000C	W	High-Speed UART transmit data register	–
HURXBUF	0xF0080010	R	High-Speed UART receive data register	–
HUBRD	0xF0080014	R/W	High-Speed UART baud rate divisor register	0x00000000
HUCHAR1	0xF0080018	R/W	High-Speed UART control character register 1	0x00000000
HUCHAR2	0xF008001C	R/W	High-Speed UART control character register 2	0x00000000
HUABB	0xF0080100	R/W	High-Speed UART autobaud boundary register	0x1F0F0703
HUABT	0xF0080104	R/W	High-Speed UART autobaud table register	0x170B0502

Table 1-13. S3C2501X I/O Port Controller

Register	Address	R/W	Description	Reset Value
IOPMODE1	0xF0030000	R/W	I/O port mode select register for port 31 to 0	0xF003FFFF
IOPMODE2	0xF0030004	R/W	I/O port mode select register for port 63 to 32	0xFFFFFFFF
IOPCON1	0xF0030008	R/W	I/O port function control register for port 31 to 0	0xFFFFFFFF00
IOPCON2	0xF003000C	R/W	I/O port function control register for port 63 to 32	0xFFFFFFFFC07
IOPGDMA	0xF0030010	R/W	I/O port special function register for GDMA	0x00000000
IOPEXTINT	0xF0030014	R/W	I/O port special function register for external interrupt	0x00000000
IOPEXTINTPND	0xF0030018	R/W	I/O port external interrupt clear register	0x00000000
IOPDATA1	0xF003001C	R/W	I/O port data register for port 31 to 0	Undefined
IOPDATA2	0xF0030020	R/W	I/O port data register for port 63 to 32	Undefined
IOPDRV1	0xF0030024	R/W	I/O port drive control register for port 31 to 0	0x00000000
IOPDRV2	0xF0030028	R/W	I/O port drive control register for port 63 to 32	0x00000000

Table 1-14. S3C2501X Interrupt Controller

Register	Address	R/W	Description	Reset Value
INTMOD	0xF0140000	R/W	Internal interrupt mode register	0x00000000
EXTMOD	0xF0140004	R/W	External interrupt mode register	0x00000000
INTMASK	0xF0140008	R/W	Internal Interrupt mask register	0xFFFFFFFF
EXTMASK	0xF014000C	R/W	External Interrupt mask register	0x8000007F
INTPRIOR0	0xF0140020	R/W	Interrupt priority register 0	0x03020100
INTPRIOR1	0xF0140024	R/W	Interrupt priority register 1	0x07060504
INTPRIOR2	0xF0140028	R/W	Interrupt priority register 2	0x0B0A0908
INTPRIOR3	0xF014002C	R/W	Interrupt priority register 3	0x0F0E0D0C
INTPRIOR4	0xF0140030	R/W	Interrupt priority register 4	0x13121110
INTPRIOR5	0xF0140034	R/W	Interrupt priority register 5	0x17161514
INTPRIOR6	0xF0140038	R/W	Interrupt priority register 6	0x1B1A1918
INTPRIOR7	0xF014003C	R/W	Interrupt priority register 7	0x1F1E1D1C
INTPRIOR8	0xF0140040	R/W	Interrupt priority register 8	0x23222120
INTPRIOR9	0xF0140044	R/W	Interrupt priority register 9	0x00262524
INTOFFSET_FIQ	0xF0140018	R	FIQ interrupt offset register	0x00000027
INTOFFSET_IRQ	0xF014001C	R	IRQ interrupt offset register	0x00000027
IPRIORHI	0xF0140010	R	High bits, 38-32 bit, Interrupt by priority register	0x00000000
IPRIORLO	0xF0140014	R	Low bits, 31-0 bit, Interrupt by priority register	0x00000000
INTTSTHI	0xF0140048	R	High bits, 38-7 bit, Interrupt test register	0x00000000
INTTSTLO	0xF014004C	R	Low bits, 6-0 bit, Interrupt test register	0x00000000

Table 1-15. S3C2501X Timer Controller

Register	Address	R/W	Description	Reset Value
TMOD	0xF0040000	R/W	Timer mode register	0x00000000
TIC	0xF0040004	R/W	Timer Interrupt Clear	0x00000000
WDT	0xF0040008	R/W	Watchdog Timer Register	0x00000000
TDATA0	0xF0040010	R/W	Timer 0 data register	0x00000000
TCNT0	0xF0040014	R/W	Timer 0 count register	0xFFFFFFFF
TDATA1	0xF0040018	R/W	Timer 1 data register	0x00000000
TCNT1	0xF004001C	R/W	Timer 1 count register	0xFFFFFFFF
TDATA2	0xF0040020	R/W	Timer 2 data register	0x00000000
TCNT2	0xF0040024	R/W	Timer 2 count register	0xFFFFFFFF
TDATA3	0xF0040028	R/W	Timer 3 data register	0x00000000
TCNT3	0xF004002C	R/W	Timer 3 count register	0xFFFFFFFF
TDATA4	0xF0040030	R/W	Timer 4 data register	0x00000000
TCNT4	0xF0040034	R/W	Timer 4 count register	0xFFFFFFFF
TDATA5	0xF0040038	R/W	Timer 5 data register	0x00000000
TCNT5	0xF004003C	R/W	Timer 5 count register	0xFFFFFFFF

2 PROGRAMMER'S MODEL

2.1 OVERVIEW

S3C2501X was developed using the advanced ARM9TDMI core designed by advanced RISC machines, Ltd.

— Processor Operating States

From the programmer's point of view, the ARM9TDMI can be in one of two states:

- ARM state which executes 32-bit, word-aligned ARM instructions.
- THUMB state which operates with 16-bit, half-word-aligned THUMB instructions. In this state, the PC uses bit 1 to select between alternate half-words.

NOTE

Transition between these two states does not affect the processor mode or the contents of the registers.

2.2 SWITCHING STATE

2.2.1 ENTERING THUMB STATE

Entry into THUMB state can be achieved by executing a BX instruction with the state bit (bit 0) set in the operand register.

Transition to THUMB state will also occur automatically on return from an exception (IRQ, FIQ, UNDEF, ABORT, SWI etc.), if the exception was entered with the processor in THUMB state.

2.2.2 ENTERING ARM STATE

Entry into ARM state happens:

1. On execution of the BX instruction with the state bit clear in the operand register.
2. On the processor taking an exception (IRQ, FIQ, RESET, UNDEF, ABORT, SWI etc.). In this case, the PC is placed in the exception mode's link register, and execution commences at the exception's vector address.

2.3 MEMORY FORMATS

ARM9TDMI views memory as a linear collection of bytes numbered upwards from zero. Bytes 0 to 3 hold the first stored word, bytes 4 to 7 the second and so on. ARM9TDMI can treat words in memory as being stored either in Big-Endian or Little-Endian format.

2.3.1 BIG-ENDIAN FORMAT

In Big-Endian format, the most significant byte of a word is stored at the lowest numbered byte and the least significant byte at the highest numbered byte. Byte 0 of the memory system is therefore connected to data lines 31 through 24.

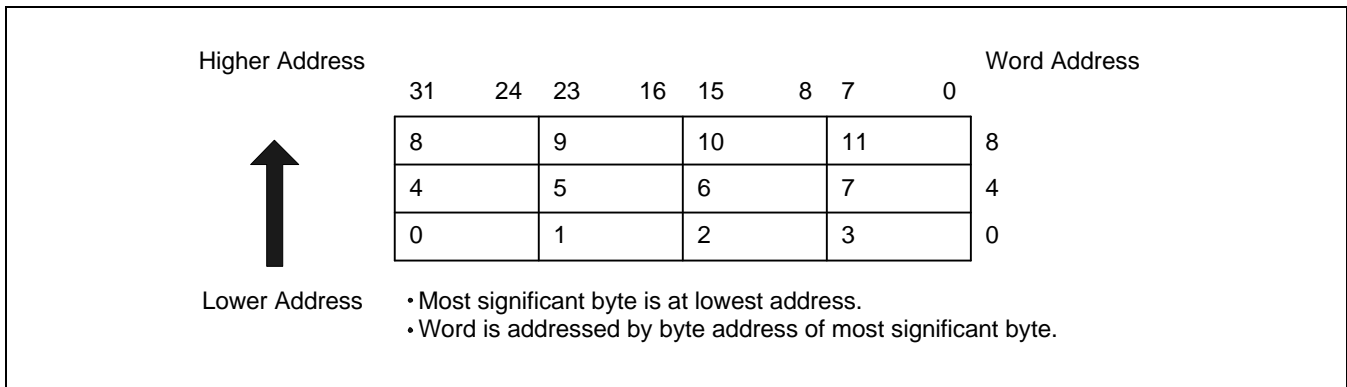

Figure 2-1. Big-Endian Addresses of Bytes within Words

NOTE

The data locations in the external memory are different with Figure 2-1 in the S3C2501X. Please refer to the chapter 4, system manager.

2.3.2 LITTLE-ENDIAN FORMAT

In Little-Endian format, the lowest numbered byte in a word is considered the word's least significant byte, and the highest numbered byte the most significant. Byte 0 of the memory system is therefore connected to data lines 7 through 0.

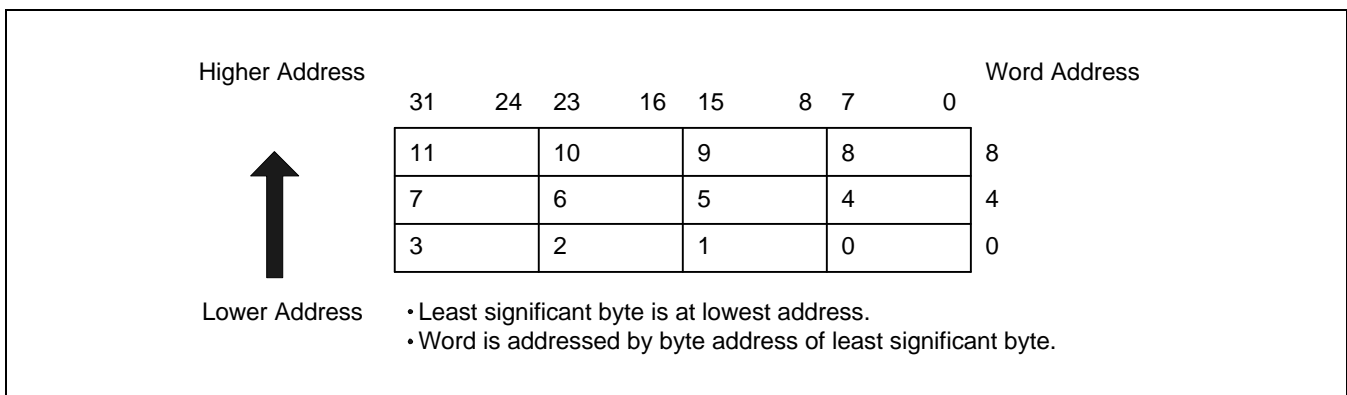

Figure 2-2. Little-Endian Addresses of Bytes Words

2.4 INSTRUCTION LENGTH

Instructions are either 32 bits long (in ARM state) or 16 bits long (in THUMB state).

2.5 DATA TYPES

ARM9TDMI supports byte (8-bit), half-word (16-bit) and word (32-bit) data types. Words must be aligned to four-byte boundaries and half words to two-byte boundaries.

2.6 OPERATING MODES

ARM9TDMI supports seven modes of operation:

User (usr):	The normal ARM program execution state
FIQ (fiq):	Designed to support a data transfer or channel process
IRQ (irq):	Used for general-purpose interrupt handling
Supervisor (svc):	Protected mode for the operating system
Abort mode (abt):	Entered after a data or instruction prefetch abort
System (sys):	A privileged user mode for the operating system
Undefined (und):	Entered when an undefined instruction is executed

Mode changes may be made under software control, or may be brought about by external interrupts or exception processing. Most application programs will execute in User mode. The non-user modes known as privileged modes-are entered in order to service interrupts or exceptions, or to access protected resources.

2.7 REGISTERS

ARM9TDMI has a total of 37 registers-31 general-purpose 32-bit registers and six status registers - but these cannot all be seen at once. The processor state and operating mode dictate which registers are available to the programmer.

2.7.1 The ARM State Register Set

In ARM state, 16 general registers and one or two status registers are visible at any one time. In privileged (non-User) modes, mode-specific banked registers are switched in. Figure 2-3 shows which registers are available in each mode: the banked registers are marked with a shaded triangle.

The ARM state register set contains 16 directly accessible registers: R0 to R15. All of these except R15 are general-purpose, and may be used to hold either data or address values. In addition to these, there is a seventeenth register used to store status information.

Register 14	is used as the subroutine link register. This receives a copy of R15 when a branch and link (BL) instruction is executed. At all other times it may be treated as a general-purpose register. The corresponding banked registers R14_svc, R14_irq, R14_fiq, R14_abt and R14_und are similarly used to hold the return values of R15 when interrupts and exceptions arise, or when branch and link instructions are executed within interrupt or exception routines.
Register 15	holds the Program Counter (PC). In ARM state, bits [1:0] of R15 are zero and bits [31:2] contain the PC. In THUMB state, bit [0] is zero and bits [31:1] contain the PC.
Register 16	is the CPSR (Current Program Status Register). This contains condition code flags and the current mode bits.

FIQ mode has seven banked registers mapped to R8-14 (R8_fiq-R14_fiq). In ARM state, many FIQ handlers do not need to save any registers. User, IRQ, Supervisor, Abort and Undefined each have two banked registers mapped to R13 and R14, allowing each of these modes to have a private stack pointer and link registers.

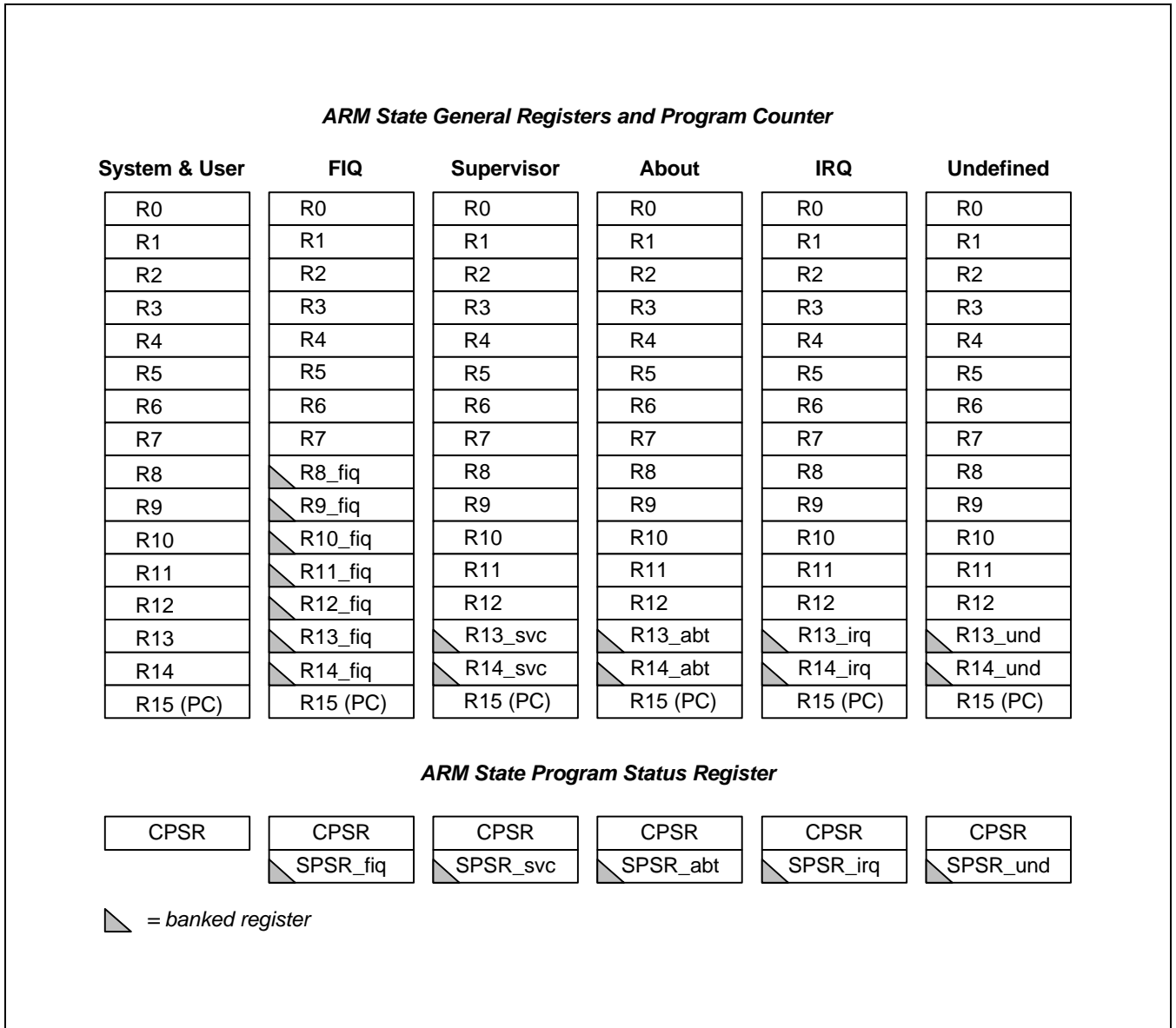

Figure 2-3. Register Organization in ARM State

2.7.2 The THUMB State Register Set

The THUMB state register set is a subset of the ARM state set. The programmer has direct access to eight general registers, R0–R7, as well as the Program Counter (PC), a stack pointer register (SP), a link register (LR), and the CPSR. There are banked stack pointers, link registers and Saved Process Status Registers (SPSRs) for each privileged mode. This is shown in Figure 2-4.

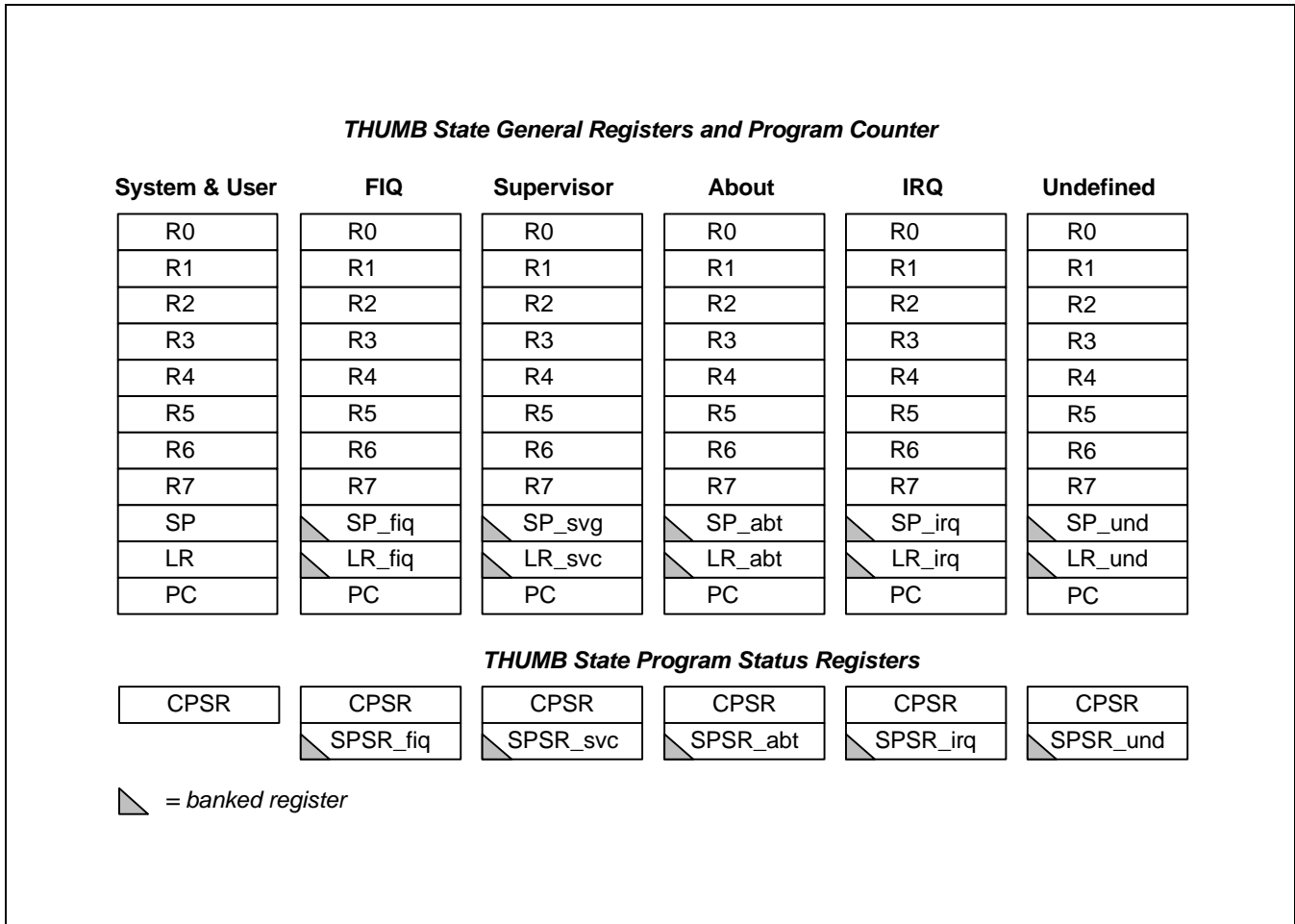

Figure 2-4. Register Organization in THUMB State

2.7.3 THE RELATIONSHIP BETWEEN ARM AND THUMB STATE REGISTERS

The THUMB state registers relate to the ARM state registers in the following way:

- THUMB state R0–R7 and ARM state R0–R7 are identical
- THUMB state CPSR and SPSRs and ARM state CPSR and SPSRs are identical
- THUMB state SP maps onto ARM state R13
- THUMB state LR maps onto ARM state R14

The THUMB state program counter maps onto the ARM state program counter (R15)

This relationship is shown in Figure 2-5.

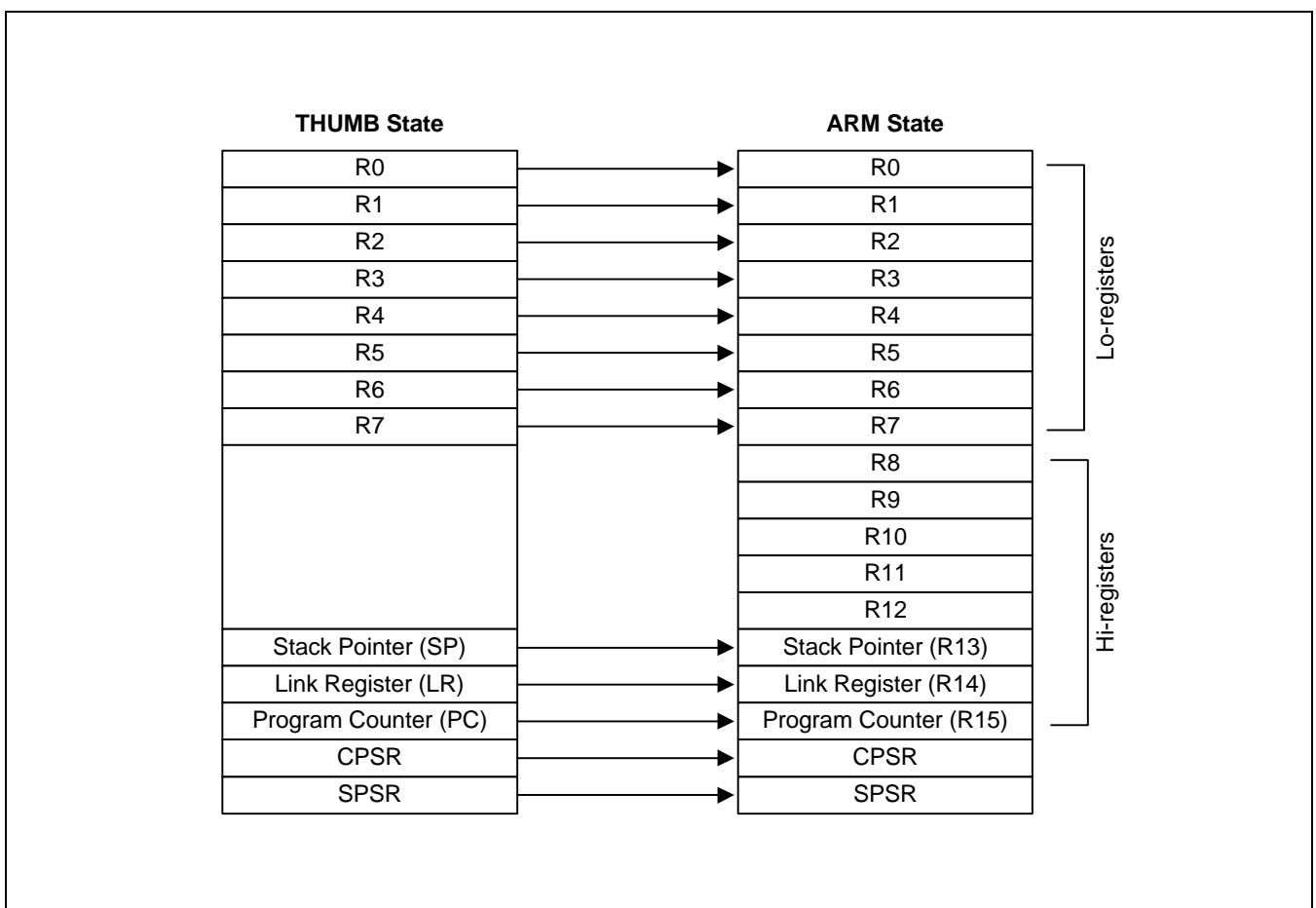

Figure 2-5. Mapping of THUMB State Registers onto ARM State Registers

2.7.4 ACCESSING HI-REGISTERS IN THUMB STATE

In THUMB state, registers R8–R15 (the Hi registers) are not part of the standard register set. However, the assembly language programmer has limited access to them, and can use them for fast temporary storage.

A value may be transferred from a register in the range R0–R7 (a Lo register) to a Hi register, and from a Hi register to a Lo register, using special variants of the MOV instruction. Hi register values can also be compared against or added to Lo register values with the CMP and ADD instructions. For more information, refer to Figure 3-34.

2.8 THE PROGRAM STATUS REGISTERS

The ARM9TDMI contains a Current Program Status Register (CPSR), plus five Saved Program Status Registers (SPSRs) for use by exception handlers. These register's functions are:

- Hold information about the most recently performed ALU operation
- Control the enabling and disabling of interrupts
- Set the processor operating mode

The arrangement of bits is shown in Figure 2-6.

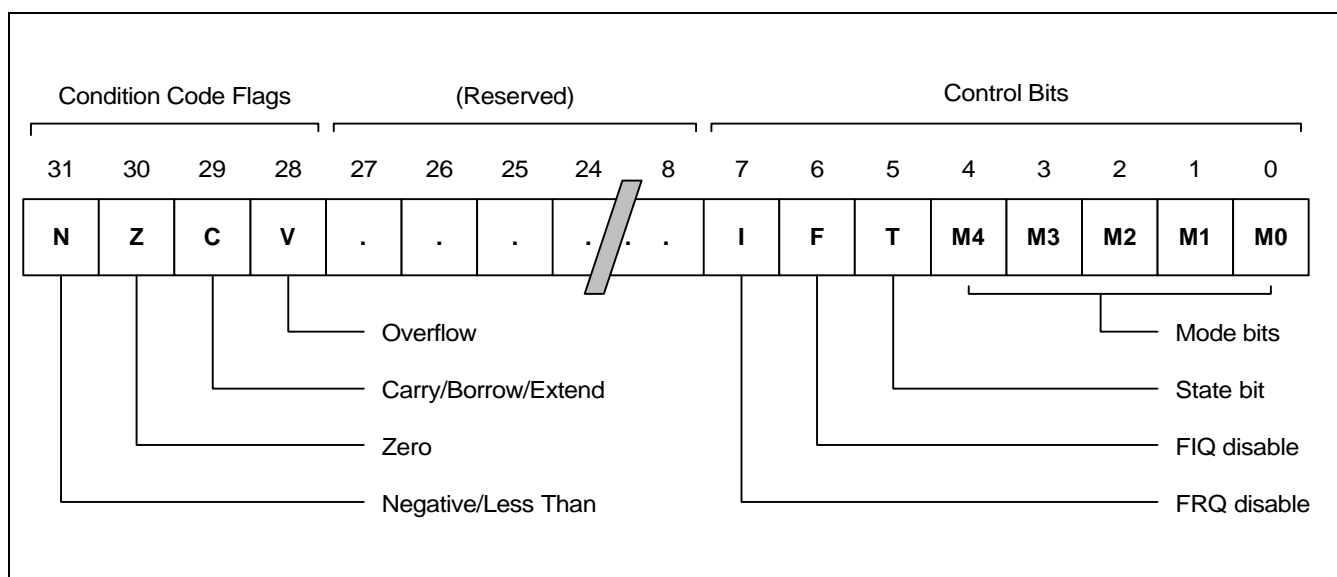

Figure 2-6. Program Status Register Format

2.8.1 THE CONDITION CODE FLAGS

The N, Z, C and V bits are the condition code flags. These may be changed as a result of arithmetic and logical operations, and may be tested to determine whether an instruction should be executed.

In ARM state, all instructions may be executed conditionally: see Table 3-2 for details.

In THUMB state, only the branch instruction is capable of conditional execution: see Figure 3-46 for details.

2.8.2 THE CONTROL BITS

The bottom 8 bits of a PSR (incorporating I, F, T and M[4:0]) are known collectively as the control bits. These will change when an exception arises. If the processor is operating in a privileged mode, they can also be manipulated by software.

The T bit	This reflects the operating state. When this bit is set, the processor is executing in THUMB state, otherwise it is executing in ARM state. This is reflected on the TBIT external signal. Note that the software must never change the state of the TBIT in the CPSR. If this happens, the processor will enter an unpredictable state.
Interrupt disable bits	The I and F bits are the interrupt disable bits. When set, these disable the IRQ and FIQ interrupts respectively.
The mode bits	The M4, M3, M2, M1 and M0 bits (M[4:0]) are the mode bits. These determine the processor's operating mode, as shown in Table 2-1. Not all combinations of the mode bits define a valid processor mode. Only those explicitly described shall be used. The user should be aware that if any illegal value is programmed into the mode bits, M[4:0], then the processor will enter an unrecoverable state. If this occurs, reset should be applied.

Table 2-1. PSR Mode. Bit Values

M[4:0]	Mode	Visible THUMB State Registers	Visible ARM State Registers
10000	User	R7..R0, LR, SP PC, CPSR	R14..R0, PC, CPSR
10001	FIQ	R7..R0, LR_fiq, SP_fiq PC, CPSR, SPSR_fiq	R7..R0, R14_fiq..R8_fiq, PC, CPSR, SPSR_fiq
10010	IRQ	R7..R0, LR_irq, SP_irq PC, CPSR, SPSR_irq	R12..R0, R14_irq..R13_irq, PC, CPSR, SPSR_irq
10011	Supervisor	R7..R0, LR_svc, SP_svc, PC, CPSR, SPSR_svc	R12..R0, R14_svc..R13_svc, PC, CPSR, SPSR_svc
10111	Abort	R7..R0, LR_abt, SP_abt, PC, CPSR, SPSR_abt	R12..R0, R14_abt..R13_abt, PC, CPSR, SPSR_abt
11011	Undefined	R7..R0 LR_und, SP_und, PC, CPSR, SPSR_und	R12..R0, R14_und..R13_und, PC, CPSR
11111	System	R7..R0, LR, SP PC, CPSR	R14..R0, PC, CPSR

Reserved bits

The remaining bits in the PSRs are reserved. When changing a PSR's flag or control bits, you must ensure that these unused bits are not altered. Also, your program should not rely on them containing specific values, since in future processors they may read as one or zero.

2.9 EXCEPTIONS

Exceptions arise whenever the normal flow of a program has to be halted temporarily, for example to service an interrupt from a peripheral. Before an exception can be handled, the current processor state must be preserved so that the original program can resume when the handler routine has finished.

It is possible for several exceptions to arise at the same time. If this happens, they are dealt with in a fixed order. See Exception Priorities on page 2-15.

2.9.1 ACTION ON ENTERING AN EXCEPTION

When handling an exception, the ARM9TDMI:

1. Preserves the address of the next instruction in the appropriate Link Register. If the exception has been entered from ARM state, then the address of the next instruction is copied into the Link Register (that is, current PC + 4 or PC + 8 depending on the exception. See Table 2-2 on for details). If the exception has been entered from THUMB state, then the value written into the Link Register is the current PC offset by a value such that the program resumes from the correct place on return from the exception. This means that the exception handler need not determine which state the exception was entered from. For example, in the case of SWI, MOV_S PC, R14_svc will always return to the next instruction regardless of whether the SWI was executed in ARM or THUMB state.
2. Copies the CPSR into the appropriate SPSR
3. Forces the CPSR mode bits to a value which depends on the exception
4. Forces the PC to fetch the next instruction from the relevant exception vector

It may also set the interrupt disable flags to prevent otherwise unmanageable nesting of exceptions.

If the processor is in THUMB state when an exception occurs, it will automatically switch into ARM state when the PC is loaded with the exception vector address.

2.9.2 ACTION ON LEAVING AN EXCEPTION

On completion, the exception handler:

1. Moves the Link Register, minus an offset where appropriate, to the PC. (The offset will vary depending on the type of exception.)
2. Copies the SPSR back to the CPSR
3. Clears the interrupt disable flags, if they were set on entry

NOTE

An explicit switch back to THUMB state is never needed, since restoring the CPSR from the SPSR automatically sets the T bit to the value it held immediately prior to the exception.

2.9.3 EXCEPTION ENTRY/EXIT SUMMARY

Table 2-2 summarizes the PC value preserved in the relevant R14 on exception entry, and the recommended instruction for exiting the exception handler.

Table 2-2. Exception Entry/Exit

	Return Instruction	Previous State		Notes
		ARM R14_x	THUMB R14_x	
BL	MOV PC, R14	PC + 4	PC + 2	1
SWI	MOVS PC, R14_svc	PC + 4	PC + 2	1
UDEF	MOVS PC, R14_und	PC + 4	PC + 2	1
FIQ	SUBS PC, R14_fiq, #4	PC + 4	PC + 4	2
IRQ	SUBS PC, R14_irq, #4	PC + 4	PC + 4	2
PABT	SUBS PC, R14_abt, #4	PC + 4	PC + 4	1
DABT	SUBS PC, R14_abt, #8	PC + 8	PC + 8	3
RESET	NA	–	–	4

NOTES:

1. Where PC is the address of the BL/SWI/Undefined Instruction fetch which had the prefetch abort.
2. Where PC is the address of the instruction which did not get executed since the FIQ or IRQ took priority.
3. Where PC is the address of the Load or Store instruction which generated the data abort.
4. The value saved in R14_svc upon reset is unpredictable.

2.9.4 FIQ

The FIQ (Fast Interrupt Request) exception is designed to support a data transfer or channel process, and in ARM state has sufficient private registers to remove the need for register saving (thus minimizing the overhead of context switching).

FIQ is externally generated by taking the nFIQ input LOW. This input can except either synchronous or asynchronous transitions, depending on the state of the ISYNC input signal. When ISYNC is LOW, nFIQ and nIRQ are considered asynchronous, and a cycle delay for synchronization is incurred before the interrupt can affect the processor flow.

Irrespective of whether the exception was entered from ARM or Thumb state, a FIQ handler should leave the interrupt by executing

```
SUBS    PC,R14_fiq,#4
```

FIQ may be disabled by setting the CPSR's F flag (but note that this is not possible from User mode). If the F flag is clear, ARM9TDMI checks for a LOW level on the output of the FIQ synchroniser at the end of each instruction.

2.9.5 IRQ

The IRQ (Interrupt Request) exception is a normal interrupt caused by a LOW level on the nIRQ input. IRQ has a lower priority than FIQ and is masked out when a FIQ sequence is entered. It may be disabled at any time by setting the I bit in the CPSR, though this can only be done from a privileged (non-User) mode.

Irrespective of whether the exception was entered from ARM or Thumb state, an IRQ handler should return from the interrupt by executing

```
SUBS    PC,R14_irq,#4
```

2.9.6 ABORT

An abort indicates that the current memory access cannot be completed. It can be signalled by the external ABORT input. ARM9TDMI checks for the abort exception during memory access cycles.

There are two types of abort:

- Prefetch abort: occurs during an instruction prefetch.
- Data abort: occurs during a data access.

If a prefetch abort occurs, the prefetched instruction is marked as invalid, but the exception will not be taken until the instruction reaches the head of the pipeline. If the instruction is not executed - for example because a branch occurs while it is in the pipeline - the abort does not take place.

If a data abort occurs, the action taken depends on the instruction type:

- Single data transfer instructions (LDR, STR) write back modified base registers: the Abort handler must be aware of this.
- The swap instruction (SWP) is aborted as though it had not been executed.
- Block data transfer instructions (LDM, STM) complete. If write-back is set, the base is updated. If the instruction would have overwritten the base with data (ie it has the base in the transfer list), the overwriting is prevented. All register overwriting is prevented after an abort is indicated, which means in particular that R15 (always the last register to be transferred) is preserved in an aborted LDM instruction.

The abort mechanism allows the implementation of a demand paged virtual memory system. In such a system the processor is allowed to generate arbitrary addresses. When the data at an address is unavailable, the Memory Management Unit (MMU) signals an abort. The abort handler must then work out the cause of the abort, make the requested data available, and retry the aborted instruction. The application program needs no knowledge of the amount of memory available to it, nor is its state in any way affected by the abort.

After fixing the reason for the abort, the handler should execute the following irrespective of the state (ARM or Thumb):

```
SUBS    PC,R14_abt,#4      ; for a prefetch abort, or
SUBS    PC,R14_abt,#8      ; for a data abort
```

This restores both the PC and the CPSR, and retries the aborted instruction.

2.9.7 SOFTWARE INTERRUPT

The software interrupt instruction (SWI) is used for entering Supervisor mode, usually to request a particular supervisor function. A SWI handler should return by executing the following irrespective of the state (ARM or Thumb):

```
MOV    PC,R14_svc
```

This restores the PC and CPSR, and returns to the instruction following the SWI.

NOTE

nFIQ, nIRQ, ISYNC, LOCK, BIGEND, and ABORT pins exist only in the ARM9TDMI CPU core.

2.9.8 UNDEFINED INSTRUCTION

When ARM9TDMI comes across an instruction which it cannot handle, it takes the undefined instruction trap. This mechanism may be used to extend either the THUMB or ARM instruction set by software emulation.

After emulating the failed instruction, the trap handler should execute the following irrespective of the state (ARM or Thumb):

```
MOVS   PC,R14_und
```

This restores the CPSR and returns to the instruction following the undefined instruction.

2.10 EXCEPTION VECTORS

The following table shows the exception vector addresses.

Table 2-3. Exception Vectors

Address	Exception	Mode in Entry
0x00000000	Reset	Supervisor
0x00000004	Undefined instruction	Undefined
0x00000008	Software Interrupt	Supervisor
0x0000000C	Abort (prefetch)	Abort
0x00000010	Abort (data)	Abort
0x00000014	Reserved	Reserved
0x00000018	IRQ	IRQ
0x0000001C	FIQ	FIQ

2.10.1 EXCEPTION PRIORITIES

When multiple exceptions arise at the same time, a fixed priority system determines the order in which they are handled:

Highest priority:

1. Reset
2. Data abort
3. FIQ
4. IRQ
5. Prefetch abort

Lowest priority:

6. Undefined Instruction, Software interrupt.

2.10.2 NOT ALL EXCEPTIONS CAN OCCUR AT ONCE:

Undefined Instruction and Software Interrupt are mutually exclusive, since they each correspond to particular (non-overlapping) decoding of the current instruction.

If a data abort occurs at the same time as a FIQ, and FIQs are enabled (ie the CPSR's F flag is clear), ARM9TDMI enters the data abort handler and then immediately proceeds to the FIQ vector. A normal return from FIQ will cause the data abort handler to resume execution. Placing data abort at a higher priority than FIQ is necessary to ensure that the transfer error does not escape detection. The time for this exception entry should be added to worst-case FIQ latency calculations.

2.11 INTERRUPT LATENCIES

The worst case latency for FIQ, assuming that it is enabled, consists of the longest time the request can take to pass through the synchroniser ($T_{syncmax}$ if asynchronous), plus the time for the longest instruction to complete (T_{ldm} , the longest instruction is an LDM which loads all the registers including the PC), plus the time for the data abort entry (T_{exc}), plus the time for FIQ entry (T_{fiq}). At the end of this time ARM9TDMI will be executing the instruction at 0x1C.

$T_{syncmax}$ is 3 processor cycles, T_{ldm} is 20 cycles, T_{exc} is 3 cycles, and T_{fiq} is 2 cycles. The total time is therefore 28 processor cycles. This is just over 1.4 microseconds in a system which uses a continuous 20 MHz processor clock. The maximum IRQ latency calculation is similar, but must allow for the fact that FIQ has higher priority and could delay entry into the IRQ handling routine for an arbitrary length of time. The minimum latency for FIQ or IRQ consists of the shortest time the request can take through the synchroniser ($T_{syncmin}$) plus T_{fiq} . This is 4 processor cycles.

2.12 RESET

When the nRESET signal goes LOW, ARM9TDMI abandons the executing instruction and then continues to fetch instructions from incrementing word addresses.

When nRESET goes HIGH again, ARM9TDMI:

1. Overwrites R14_svc and SPSR_svc by copying the current values of the PC and CPSR into them. The value of the saved PC and SPSR is not defined.
2. Forces M[4:0] to 10011 (Supervisor mode), sets the I and F bits in the CPSR, and clears the CPSR's T bit.
3. Forces the PC to fetch the next instruction from address 0x00.
4. Execution resumes in ARM state.

2.13 INTRODUCTION FOR ARM940T

The ARM940T cached processor macrocell is a member of the ARM9 Thumb Family of high-performance 32-bit system-on-a-chip processor solutions. It is targeted at a wide range of embedded control applications where high performance, low system cost, small die size, and low power are key considerations.

The ARM940T processor macrocell provides a complete high performance CPU subsystem, including ARM9TDMI RISC integer CPU, caches, write buffer, and protection unit, with an AMBA ASB bus interface. Providing a complete high-frequency CPU subsystem frees the system-on-a-chip designer to concentrate on design issues unique to their system.

The ARM9TDMI core within the ARM940T macrocell executes both the 32-bit ARM and 16-bit Thumb instruction sets, allowing the user to trade off between high performance and high code density. It is binary compatible with ARM7TDMI, ARM10TDMI, and StrongARM processors, and is supported by a wide range of tools, operating systems, and application software.

The ARM940T processor macrocell is designed to be integrated into larger chips. It supports EmbeddedICE software and hardware debug and efficient production test when embedded in larger devices. The Advanced Microcontroller Bus Architecture (AMBA) provides a high performance 32-bit System Bus (ASB) and a low power peripheral bus (APB). The ASB is re-used to provide a channel for production test vectors with low silicon and pin overhead. The ASB is a multi-master on-chip bus interface designed specifically to address the needs of system-on-a-chip designs.

The EmbeddedICE software and hardware debug features of the ARM940T macrocell are accessed via a standard 5-pin JTAG port, and are supported by ARM's Software Development Toolkit and Multi-ICE interface hardware. The EmbeddedICE features allow software download and debug of the final production system with no cost overhead (there is no monitor code or other use of target resident RAM or ROM).

The ARM940T processor has a Harvard cache architecture with separate 4KB instruction and 4KB data caches, each with a 4-word line length. A protection unit allows 8 regions of memory to be defined, each with individual cache and write buffer configurations and access permissions. The cache system is software configurable to provide highest average performance or to meet the needs of real-time systems.

Software configurable options include:

- Random or round robin replacement algorithm
- Write-through or write-back cache operation (independently selectable for each memory region)
- Cache locking with granularity 1/64 th of cache size.

Overall, the cache and write buffers improve CPU performance and minimize accesses to the AMBA bus and to any off-chip memory, thus reducing overall system power consumption.

The ARM940T includes support for coprocessors, allowing a floating point unit or other application specific hardware acceleration to be added.

To minimize die size and power consumption the ARM940T does not provide virtual to physical address mapping as this is not required in most embedded applications. For systems requiring virtual memory capability, ARM provides an alternative product, the ARM920T cached processor macrocell. The ARM940T also features a TrackingICE mode which allows an approach similar to a conventional ICE mode of operation.

2.14 ARM940T BLOCK DIAGRAM

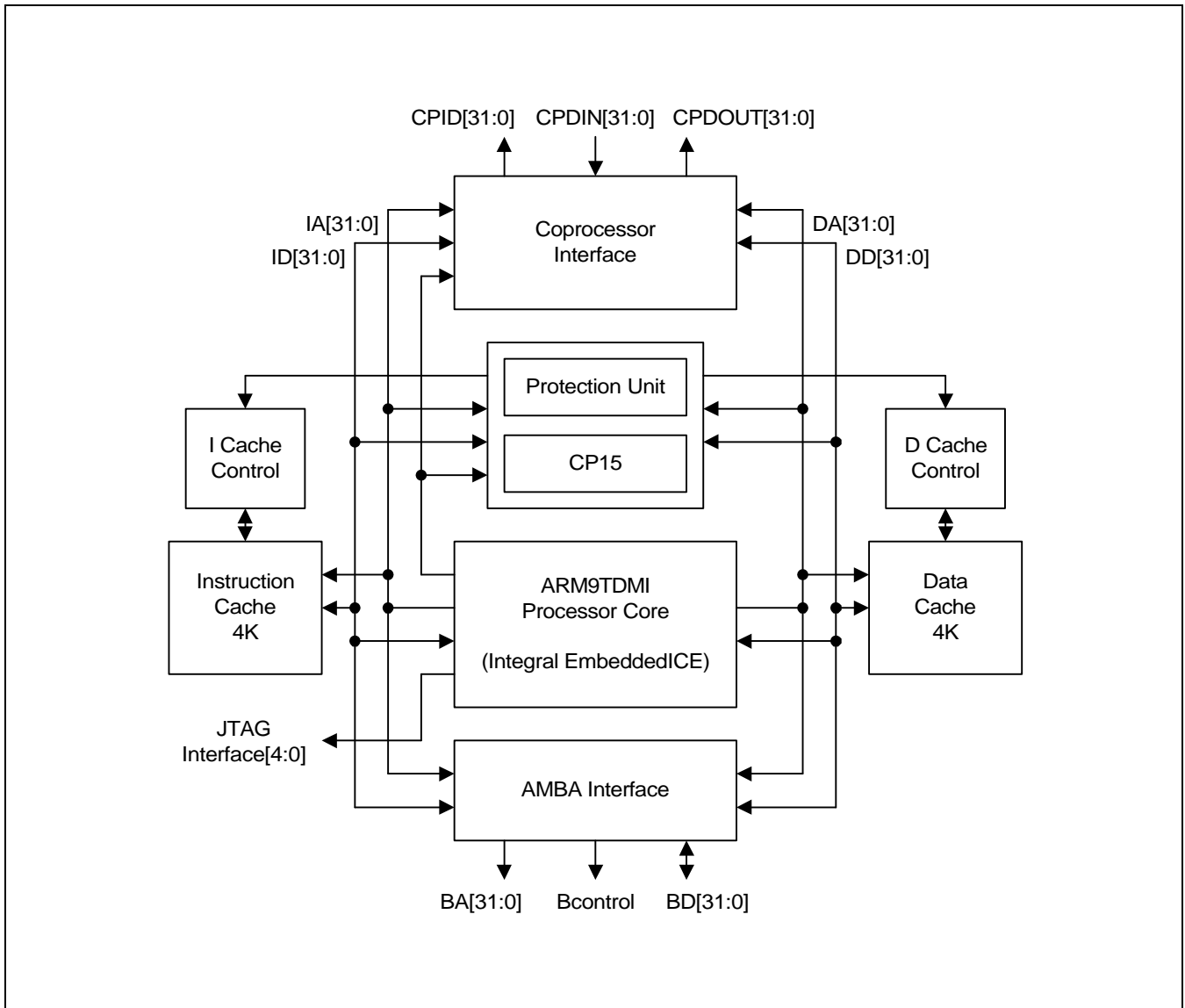

Figure 2-7. ARM940T Block Diagram

2.15 ABOUT THE ARM940T PROGRAMMER'S MODEL

The ARM940T cached processor macrocell includes the ARM9TDMI microprocessor core, instruction and data caches, a write-buffer, and a protection unit for defining the attributes of regions of memory.

The ARM940T incorporates two coprocessors:

- CP14 which allows software access to the debug communications channel
- CP15 which allows configuration of the caches, protection unit, and other system options such as big or little endian operation.

The ARM940T also features an external coprocessor interface which allows the attachment of a closely coupled coprocessor on the same chip, for example, a floating point unit.

The programmer's model of the ARM940T consists of the programmer's model of the ARM9TDMI with the following additions and modifications:

- Memory accesses for instruction fetches and data loads and stores may be cached or buffered. Cache and write buffer configuration and operation is described in detail in following chapters.
- The registers defined in CP14 are accessible with MCR and MRC instructions.
- The registers defined in CP15 are accessible with MCR and MRC instructions.
- Registers and operations provided by any coprocessors attached to the external coprocessor interface will be accessible with appropriate coprocessor instructions.

The ARM9TDMI processor core implements ARM Architecture v4T, and so executes the ARM 32-bit instruction set and the compressed Thumb 16-bit instruction set. The programmer's model is fully described in the ARM Architecture Reference Manual.

The ARM v4T architecture specifies a small number of implementation options. The options selected in the ARM9TDMI implementation are listed in Table 2-4. For comparison, the options selected for the ARM9TDMI implementation are also shown.

Table 2-4. ARM9TDMI Implementation Option

Processor Core	ARM Architecture	Data Abort Mode	Value Stored by Direct STR, STRT, STM of PC
ARM7TDMI	v4T	Base updated	Address of Inst + 12
ARM9TDMI	v4T	Base restored	Address of Inst + 12

The ARM9TDMI is code-compatible with the ARM7TDMI, with two exceptions:

- The ARM9TDMI implements the base restored data abort model, which significantly simplifies the software data abort handler.
- The ARM9TDMI fully implements the instruction set extension spaces added to the ARM (32-bit) instruction set in architecture v4 and v4T.

These differences are explained in more detail below.

2.15.1 DATA ABORT MODEL

The base restored data abort model differs from the base updated data abort model implemented by ARM7TDMI.

The difference in the data abort model affects only a very small section of operating system code, the data abort handler. It does not affect user code. With the base restored data abort model, when a data abort exception occurs during the execution of a memory access instruction, the base register is always restored by the processor hardware to the value the register contained before the instruction was executed. This removes the need for the data abort handler to unwind any base register update which may have been specified by the aborted instruction.

The base restored data abort model significantly simplifies the software data abort handler.

2.15.2 INSTRUCTION SET EXTENSION SPACES

All ARM processors implement the undefined instruction space as one of the entry mechanisms for the undefined instruction exception. That is, ARM instructions with opcode[27:25] = 0b011 and opcode[4] = 1 are undefined on all ARM processors including the ARM9TDMI and ARM7TDMI.

ARM Architecture v4 and v4T also introduced a number of instruction set extension spaces to the ARM instruction set. These are:

- Arithmetic instruction extension space
- Control instruction extension space
- Coprocessor instruction extension space
- Load/store instruction extension space.

Instructions in these spaces are undefined (they cause an undefined instruction exception). The ARM9TDMI fully implements all the instruction set extension spaces defined in ARM Architecture v4T as undefined instructions, allowing emulation of future instruction set additions.

2.16 ARM940T CP15 REGISTERS

2.16.1 CP15 REGISTER MAP SUMMARY

The ARM940T incorporates CP15 for system control. The register map for C15 is shown in Table 2-5.

Table 2-5. CP15 Register Map

Register	Function	Access
0	ID code/Cache type	See note below
1	Control	Read/write
2	Cacheable	See note below
3	Write buffer control	Read/write
4	Reserved	Undefined
5	Protection region access permissions	See note below
6	Protection region base/size control	See note below
7	Cache operations	Write only. Reads unpredictable
8	Reserved	Undefined
9	Cache lockdown	Read/write
10-14	Reserved	Undefined
15	Test	Not accessed in normal operations

NOTE: Register locations 0, 2, 5, and 6 each provide access to more than one register. The register accessed depends upon the value of the opcode_2 field. See the register descriptions that follow for further information.

2.16.1.1 Register 0: ID code

This is a read-only register which returns a 32-bit device ID code. The ID code register is accessed by reading CP15 register 0 with the opcode_2 field set to any value other than 1. For example:

```
MRC p15, 0, rd, c0, c0,{0,2-7}; returns ID register
```

The contents of the ID code are shown in Table 2-6.

Table 2-6. ID Code Register

Register Bits	Function	Value
31:12	Implementor	0x41 (identifies ARM)
23:16	Architecture version	0x2
15:4	Part number	0x940
3:0	Version	0x1

2.16.1.2 Register 0: Cache type

This is a read-only register which allows operating systems to establish how to perform operations such as cache cleaning and lockdown. Future ARM cached processors will contain this register, allowing RTOS vendors to produce future-proof versions of their operating systems.

The cache type register is accessed by reading CP15 register 0 with the opcode_2 field set to 1. For example:

```
MRC p15, 0, rd, c0, c0, 1; returns Cache type register
```

The register contains information about the size and architecture of the caches. The format of the register is shown in Table 2-7.

Table 2-7. Cache Type Register Format

Register Bits	Meaning	Value
31:29	Reserved	000
28:25	Cache type	0111
24	Harvard/Unified	1 (defines Harvard cache)
23:21	Reserved	000
20:18	DCache size	011 (defines 4KB)
17:15	DCache associativity	110 (defines 64 way)
14	DCache base size	0 (defines 1x base parameters)
13:12	DCache words per line	01 (defines 4 words per line)
11:9	Reserved	000
8:6	ICache size	011 (defines 4KB)
5:3	ICache Associativity	110 (defines 64 way)
2	ICache base size	0 (defines 1x base parameters)
1:0	ICache words per line	01 (defines 4 words per line)

2.16.1.3 Register 1: Control register

This contains the global control bits of the ARM940T. All reserved bits should either be written with zero or one, as indicated, or written using read-modify-write. The reserved bits have an unpredictable value when read. All defined bits in the control registers are set to zero at reset.

Table 2-8. CP15 Register 1

Register Bits	Functions
31	Asynchronous clocking select (iA)
30	nFastBus select (nF)
29:14	Reserved (should be zero)
13	Alternate vectors select (V)
12	ICache enable bit (1)
11:8	Reserved (should be zero)
7	Big-end bit (E)
6:3	Reserved (should be one)
2	DCache enable bit (D)
1	Reserved (should be zero)
0	Protection unit enable (P)

The bits in the control register have the following functions:

- Bits 31:30 Control the clocking mode of the processor, as shown in Table 2-9. Clocking modes are discussed in Chapter5 Clock Modes.

Table 2-9. Clocking Modes

Clockin Mode	Bit 31	Bit 30
FastBus mode	0	0
Reserved	1	0
Synchronous	0	1
Asynchronous	1	1

- Bit 13 Selects the location of the vector table. During reset, the bit is cleared and the vector table is located at address 0x00000000. When bit 13 is set, the vector table is relocated to address 0xffff0000.
- Bits 12 and 2 Enable the caches
- Bit 7 Selects the endian configuration of the ARM940T. Setting bit 7 selects a big-endian configuration. Clearing bit 7 selects a little-endian configuration. Bit 7 is cleared during reset.
- Bit 0 Enables the protection unit

2.16.1.4 Register 2: Instruction and data cacheable registers

This location provides access to two registers which contain the cacheable attributes for each of eight memory areas. The two registers provide individual control for the I and D address spaces. The opcode_2 field determines whether the instruction-or data-cacheable attributes are programmed:

If the opcode_2 field = 0, the data-cacheable bits are programmed. For example:

MCR p15,0,Rd,c2,c0,0; Write data-cacheable bits

MRC p15,0,Rd,c2,c0,0; Read data-cacheable bits

If the opcode_2 field = 1 the instruction-cacheable bits are programmed. For example:

MCR p15,0,Rd,c2,c0,1; Write instruction cacheable bits

MRC p15,0,Rd,c2,c0,1; Read instruction cacheable bits

The format for the data and instruction cacheable bits is similar, as shown in Table2-10. Setting a bit makes an area cacheable, clearing it makes it non-cacheable.

All defined bits in the cacheable registers are set to zero at reset.

Table 2-10. Cacheable Register Format

Register Bits	Functions
7	Cacheable bit (C_7) for area 7
6	Cacheable bit (C_6) for area 6
5	Cacheable bit (C_5) for area 5
4	Cacheable bit (C_4) for area 4
3	Cacheable bit (C_3) for area 3
2	Cacheable bit (C_2) for area 2
1	Cacheable bit (C_1) for area 1
0	Cacheable bit (C_0) for area 0

2.16.1.5 Register 3: Write buffer control register

This register contains a write buffer control (bufferable) attribute bit for each of the eight areas of memory. Each bit is used in conjunction with the cacheable bit to control write-buffer operation.

Setting a bit makes an area bufferable, clearing a bit makes an area unbuffered. For example:

MCR p15,0,Rd,c3,c0,0; Write data-bufferable bits

MRC p15,0,Rd,c3,c0,0; Read data-bufferable bits

NOTE

The opcode_2 field should be 0 because the write buffer only operates on data regions. The following table, therefore, only applies to the DCache.

All defined bits in the write buffer control register are set to zero at reset.

Table 2-11. Write Buffer Control Register

Register Bits	Functions
7	Write buffer control bit (B_d7) for data area 7
6	Write buffer control bit (B_d6) for data area 6
5	Write buffer control bit (B_d5) for data area 5
4	Write buffer control bit (B_d4) for data area 4
3	Write buffer control bit (B_d3) for data area 3
2	Write buffer control bit (B_d2) for data area 2
1	Write buffer control bit (B_d1) for data area 1
0	Write buffer control bit (B_d0) for data area 0

2.16.1.6 Register 5: Instruction and data space protection registers

These registers contain the access permission bits for the instruction and data protection regions. The opcode_2 field determines whether the instruction or data access permissions are programmed.

If the opcode_2 field = 0, the data space bits are programmed. For example:

MCR p15,0,Rd,c5,c0,0; Write data space access permissions

MRC p15,0,Rd,c5,c0,0; Read data space access permissions

If the opcode_2 field =1, the instruction space bits are programmed. For example:

MCR p15,0,Rd,c5,c0,1; Write instruction space access permissions

MRC p15,0,Rd,c5,c0,1; Read instruction space access permissions

Each register contains the access permission bits, $apn[1:0]$, for the eight areas of instruction or data memory, as shown in Table 2-12.

All defined bits in the protection registers are set to zero at reset.

Table 2-12. Protection Space Register Format

Register Bits	Functions
15:14	$ap7[1:0]$ bits of area 7
13:12	$ap6[1:0]$ bits of area 6
11:10	$ap5[1:0]$ bits of area 5
9:8	$ap4[1:0]$ bits of area 4
7:6	$ap3[1:0]$ bits of area 3
5:4	$ap2[1:0]$ bits of area 2
3:2	$ap1[1:0]$ bits of area 1
1:0	$ap0[1:0]$ bits of area 0

The values of the $lapn[1:0]$ and $Dapn[1:0]$ bits define the access permission for each area of memory. The encoding is shown in Table 2-13.

NOTE

On reset, the values of the $lapn[1:0]$ and $Dapn[1:0]$ bits for all areas are undefined. However, as on reset, the protection unit is disabled and all areas are effectively set to no access. The protection space registers therefore, must be programmed before the protection unit is enabled.

Table 2-13. Permission Encoding

I/Dapn[1:0]	Permission
00	No access.
01	Privileged mode access only.
10	Privileged mode full access, user mode read only.
11	Full access.

2.16.1.7 Register 6: Protection region base and size registers

This register is used to define 16 programmable regions (eight instruction, eight data) in memory. These registers define the base and size of each of the eight areas of memory. Individual control is provided for the instruction and data memory regions. The values are ignored when the protection unit is disabled.

On reset, only the region enable bit for each region is reset to 0, all other bits are undefined. At least one instruction and data memory region must be programmed before the protection unit is enabled.

The opcode_2 field defines whether the data or instruction protection regions are to be programmed. The CRm field selects the region number.

Table 2-14. CP15 Data Protection Region Registers

ARM instruction	Protection region register
MCR/MRC p15, 0, Rd, c6, c7, 0	Data memory region 7
MCR/MRC p15, 0, Rd, c6, c6, 0	Data memory region 6
MCR/MRC p15, 0, Rd, c6, c5, 0	Data memory region 5
MCR/MRC p15, 0, Rd, c6, c4, 0	Data memory region 4
MCR/MRC p15, 0, Rd, c6, c3, 0	Data memory region 3
MCR/MRC p15, 0, Rd, c6, c2, 0	Data memory region 2
MCR/MRC p15, 0, Rd, c6, c1, 0	Data memory region 1
MCR/MRC p15, 0, Rd, c6, c0, 0	Data memory region 0

Table 2-15. CP15 Instruction Protection Region Registers

ARM instruction	Protection region register
MCR/MRC p15, 0, Rd, c6, c7, 1	Instruction memory region 7
MCR/MRC p15, 0, Rd, c6, c6, 1	Instruction memory region 6
MCR/MRC p15, 0, Rd, c6, c5, 1	Instruction memory region 5
MCR/MRC p15, 0, Rd, c6, c4, 1	Instruction memory region 4
MCR/MRC p15, 0, Rd, c6, c3, 1	Instruction memory region 3
MCR/MRC p15, 0, Rd, c6, c2, 1	Instruction memory region 2
MCR/MRC p15, 0, Rd, c6, c1, 1	Instruction memory region 1
MCR/MRC p15, 0, Rd, c6, c0, 1	Instruction memory region 0

Each protection region register has the format shown in Table 2-16.

Table 2-16. CP15 Protection Region Register Format

Register bit	Function
31:12	Base address
11:6	Unused
5:1	Area size (See Table2-17)
0	Region enable. Reset to disable (0).

The region base must be aligned to an area size boundary, where the area size is defined in its respective protection region register. The behavior is undefined if this is not the case. Area sizes are given in Table 2-17.

Table 2-17. Area Size Encoding

Bit encoding	Area size	Bit encoding	Area size
00000 to 01010	Reserved	10101	4MB
01011	4KB	10110	8MB
01100	8KB	10111	16MB
01101	16KB	11000	32MB
01110	32KB	11001	64MB
01111	64KB	11010	128MB
10000	128KB	11011	256MB
10001	256KB	11100	512MB
10010	512KB	11101	1GB
10011	1MB	11110	2GB
10100	2MB	11111	4GB

2.16.1.7.1 Example Base Setting

An 8KB size region aligned to the 8KB boundary at 0x00002000 (covering the address range 0x00002000–0x00003fff) would be programmed to 0x00002019.

2.16.1.8 Register 7: Cache operations

A write to this register can be used to perform the following operations:

- Flush ICache and Dcache
- Prefetch an ICache line
- Wait for interrupt
- Drain the write buffer
- Clean and flush the DCache.

The ARM940T uses a subset of the architecture V4 functions (defined in the ARM Architecture Reference Manual). The available operations are summarized in Table 2-18 and described below.

Table 2-18. Cache Operations Writing to Register 7

ARM instruction	Data	Protection region register
MCR p15, 0, Rd, c7, c5, 0	should be zero	Flush ICache.
MCR p15, 0, Rd, c7, c5, 2	Index/segment	Flush ICache single entry.
MCR p15, 0, Rd, c7, c6, 0	should be zero	Flush DCache.
MCR p15, 0, Rd, c7, c6, 2	Index/segment	Flush DCache single entry.
MCR p15, 0, Rd, c7, c10, 2	Index/segment	Clean DCache single entry.
MCR p15, 0, Rd, c7, c13, 1	Address	Prefetch ICache line.
MCR p15, 0, Rd, c7, c14, 2	Index/segment	Clean and flush DCache single entry.
MCR p15, 0, Rd, c7, c8, 2	should be zero	Wait for interrupt.
MCR p15, 0, Rd, c7, c10, 4	should be zero	Drain write buffer.

"Should be zero" means the value transferred in the Rd.

A read from this register returns an unpredictable value.

2.16.1.8.1 Index/Segment Format

Where the required value is an index/segment, the format is:

Table 2-19. CP15 Register 7 Index/Segment Data Format

Rd bit position	Function
31:26	Index
25:6	Should be zero
5:4	Segment
3:0	Should be zero

2.16.1.8.2 ICache Prefetch Data Format

For the ICache prefetch operation, the data format is:

Table 2-20. CP15 Register 7 Prefetch Address Format

Rd bit position	Function
31:6	Address bits 31:6
5:4	Cache segment
3:0	Should be zero

2.16.1.8.3 Wait for interrupt

This operation allows the ARM940T to be placed in a low-power standby mode. When the operation is invoked, all clocks in the processor are frozen until either an interrupt or a debug request occurs. This function is invoked by a write to register 7. The following ARM instruction causes this to occur:

```
MCR p15, 0, Rd, c7, c0, 4
```

The following instruction causes the same affect and has been added for backward compatibility with StrongARM SA-1

```
MCR p15, 0, Rd, c15, c8, 2
```

This stalls the processor, with internal clocks held high from the time that this instruction is executed until one of the signals nFIQ, nIRQ, or EDBGRQ is asserted. Also, if the debugger sets the debug request bit in the EmbeddedICE unit control register, the wait-for-interrupt condition is terminated.

In the case of nFIQ and nIRQ, the processor is woken up regardless of whether the interrupts are enabled or disabled (that is, independent of the I and F bits in the processor CPSR). The debug related waking only occurs if DBGGEN is HIGH, that is, only when debug is enabled.

If the interrupts are enabled, the ARM is guaranteed to take the interrupt before executing the instruction after the wait-for-interrupt. If debug request is used to wake up the system, the processor will enter debug-state before executing any further instructions.

2.16.1.8.4 Drain Write Buffer

This CP15 operation causes instruction execution to be stalled until the write buffer is emptied. This operation is useful in real time applications where the processor needs to be sure that a write to a peripheral has completed before program execution continues. An example would be where a peripheral in a bufferable region is the source of an interrupt. Once the interrupt has been serviced, the request must be removed before interrupts can be re-enabled. This can be ensured if a drain write buffer operation separates the store to the peripheral and the enable interrupt functions.

The drain write buffer function is invoked by a write to CP15 register 7 using the following ARM instruction:

```
MCR p15, 0, Rd, c7, c10, 4
```

This stalls the processor core, with CPnWAIT asserted until any outstanding accesses in the write buffer have been completed (that is, until all data has been written to memory).

2.16.1.9 Register 9: Instruction and data lockdown registers

These registers allow regions of the cache to be locked down. The opcode_2 field determines whether the instruction or data caches are programmed.

- If the opcode_2 field = 0, the data lockdown bits are programmed. For example:

```
MCR/MRC p15, 0, Rd, c9, c0, 0; data lockdown control
```

- If the opcode_2 field = 1, the instruction lockdown bits are programmed. For example:

```
MCR/MRC p15, 0, Rd, c9, c0, 1; instruction lockdown control
```

The format of the registers, Rd, transferred during this operation, is shown below:
All defined bits in the lockdown registers are set to zero at reset.

Table 2-21. Lockdown Register Format

Register bit	Function
31	Load bit
30:6	Reserved
5:0	Cache index

NOTE: The segment number is not specified because cache lines are locked down across all four segments (16-word granularity).

2.16.1.10 Register 15: Test/debug register

The DTRRobin and ITRRobin bits set the respective caches into a pseudo round-robin replacement mode. All defined bits in the test registers are set to zero at reset.

Table 2-22. CP15 Register 15

Register bit	Function
31:4	Reserved
3	ITRRobin
2	DTRRobin
1:0	Reserved

2.16.1.11 Reserved Registers

Accessing a reserved register is unpredictable.

3 INSTRUCTION SET

3.1 INSTRUCTION SET SUMMARY

This chapter describes the ARM instruction set and the THUMB instruction set in the ARM9TDMI core.

3.1.1 FORMAT SUMMARY

The ARM instruction set formats are shown below.

31	30	29	28	27	26	25	24	23	22	21	20	19	18	17	16	15	14	13	12	11	10	9	8	7	6	5	4	3	2	1	0
Cond	0	0	1	Opcode				S	Rn	Rd	Operand2										Data processing/ PSR Transfer										
Cond	0	0	0	0	0	0	A	S	Rd	Rn	Rs	1	0	0	1	Rm	Multiply														
Cond	0	0	0	0	1	U	A	S	RdHi	RnLo	Rn	1	0	0	1	Rm	Multiply Long														
Cond	0	0	0	1	0	B	0	0	Rn	Rd	0	0	0	0	1	0	0	1	Rm	Single data swap											
Cond	0	0	0	1	0	0	1	0	1	1	1	1	1	1	1	1	1	1	1	0	0	0	1	Rn	Branch and exchange						
Cond	0	0	0	P	U	0	W	L	Rn	Rd	0	0	0	0	1	S	H	1	Rm	Halfword data transfer: register offset											
Cond	0	0	0	P	U	1	W	L	Rn	Rd	Offset			1	S	H	1	Offset	Halfword data transfer: immediate offset												
Cond	0	1	1	P	U	B	W	L	Rn	Rd	Offset						Single data transfer														
Cond	0	1	1													1	Undefined														
Cond	1	0	0	P	U	S	W	L	Rn	Register List							Block data transfer														
Cond	1	0	1	L	Offset												Branch														
Cond	1	1	0	P	U	N	W	L	Rn	CRd	CP#	Offset					Coprocessor data transfer														
Cond	1	1	1	0	CP Opc			CRn	CRd	CP#	CP#	0	CRm	Coprocessor data Operation																	
Cond	1	1	1	0	CP Opc			L	CRn	Rd	CP#	CP#	1	CRm	Coprocessor register Transfer																
Cond	1	1	1	1	Ignored by processor												Software Interrupt														
31	30	29	28	27	26	25	24	23	22	21	20	19	18	17	16	15	14	13	12	11	10	9	8	7	6	5	4	3	2	1	0

Figure 3-1. ARM Instruction Set Format

NOTE

Some instruction codes are not defined but do not cause the Undefined instruction trap to be taken, for instance a Multiply instruction with bit 6 changed to a 1. These instructions should not be used, as their action may change in future ARM implementations.

3.1.2 INSTRUCTION SUMMARY

Table 3-1. The ARM Instruction Set

Mnemonic	Instruction	Action
ADC	Add with carry	$Rd = Rn + Op2 + Carry$
ADD	Add	$Rd = Rn + Op2$
AND	AND	$Rd = Rn \text{ AND } Op2$
B	Branch	R15: = address
BIC	Bit clear	$Rd = Rn \text{ AND NOT } Op2$
BL	Branch with link	R14: = R15, R15: = address
BX	Branch and exchange	R15: = Rn, T bit: = Rn[0]
CDP	Coprocessor data processing	(coprocessor-specific)
CMN	Compare negative	CPSR flags: = Rn + Op2
CMP	Compare	CPSR flags: = Rn - Op2
EOR	Exclusive OR	$Rd = (Rn \text{ AND NOT } Op2)$ OR (op2 AND NOT Rn)
LDC	Load coprocessor from memory	Coprocessor load
LDM	Load multiple registers	Stack manipulation (Pop)
LDR	Load register from memory	$Rd = (\text{address})$
MCR	Move CPU register to coprocessor register	$cRn = rRn \{<op>cRm\}$
MLA	Multiply accumulate	$Rd = (Rm * Rs) + Rn$
MOV	Move register or constant	$Rd = Op2$
MRC	Move from coprocessor register to CPU register	$Rn = cRn \{<op>cRm\}$
MRS	Move PSR status/flags to register	$Rn = PSR$
MSR	Move register to PSR status/flags	$PSR = Rm$
MUL	Multiply	$Rd = Rm * Rs$
MVN	Move negative register	$Rd = 0xFFFFFFFF \text{ EOR } Op2$

Table 3-1. The ARM Instruction Set (Continued)

Mnemonic	Instruction	Action
ORR	OR	Rd: = Rn OR Op2
RSB	Reverse subtract	Rd: = Op2 - Rn
RSC	Reverse subtract with carry	Rd: = Op2 - Rn-1 + Carry
SBC	Subtract with carry	Rd: = Rn - Op2-1 + Carry
STC	Store coprocessor register to memory	Address: = CRn
STM	Store multiple	Stack manipulation (push)
STR	Store register to memory	<address>: = Rd
SUB	Subtract	Rd: = Rn - Op2
SWI	Software Interrupt	OS call
SWP	Swap register with memory	Rd: = [Rn], [Rn] := Rm
TEQ	Test bit-wise equality	CPSR flags: = Rn EOR Op2
TST	Test bits	CPSR flags: = Rn AND Op2

3.2 THE CONDITION FIELD

In ARM state, all instructions are conditionally executed according to the state of the CPSR condition codes and the instruction's condition field. This field (bits 31:28) determines the circumstances under which an instruction is to be executed. If the state of the C, N, Z and V flags fulfils the conditions encoded by the field, the instruction is executed, otherwise it is ignored.

There are sixteen possible conditions, each represented by a two-character suffix that can be appended to the instruction's mnemonic. For example, a branch (B in assembly language) becomes BEQ for "Branch if "Equal", which means the branch will only be taken if the Z flag is set.

In practice, fifteen different conditions may be used: these are listed in Table 3-2. The sixteenth (1111) is reserved, and must not be used.

In the absence of a suffix, the condition field of most instructions is set to "Always" (suffix AL). This means the instruction will always be executed regardless of the CPSR condition codes.

Table 3-2. Condition Code Summary

Code	Suffix	Flags	Meaning
0000	EQ	Z set	Equal
0001	NE	Z clear	Not equal
0010	CS	C set	Unsigned higher or same
0011	CC	C clear	Unsigned lower
0100	MI	N set	Negative
0101	PL	N clear	Positive or zero
0110	VS	V set	Overflow
0111	VC	V clear	No overflow
1000	HI	C set and Z clear	Unsigned higher
1001	LS	C clear or Z set	Unsigned lower or same
1010	GE	N equals V	Greater or equal
1011	LT	N not equal to V	Less than
1100	GT	Z clear AND (N equals V)	Greater than
1101	LE	Z set OR (N not equal to V)	Less than or equal
1110	AL	(Ignored)	Always

3.3 BRANCH AND EXCHANGE (BX)

This instruction is only executed if the condition is true. The various conditions are defined in Table 3-2.

This instruction performs a branch by copying the contents of a general register, Rn, into the program counter, PC. The branch causes a pipeline flush and refill from the address specified by Rn. This instruction also permits the instruction set to be exchanged. When the instruction is executed, the value of Rn[0] determines whether the instruction stream will be decoded as ARM or THUMB instructions.

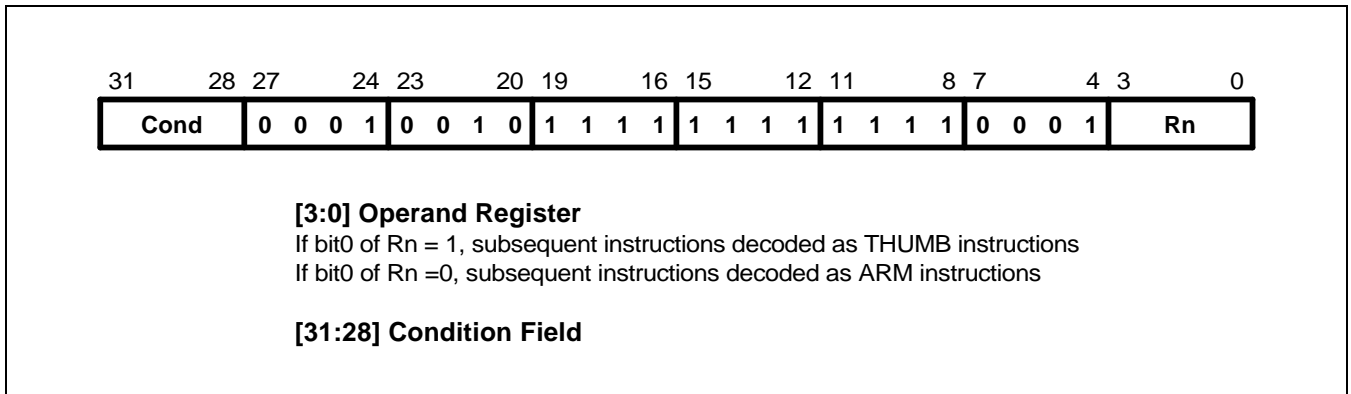

Figure 3-2. Branch and Exchange Instructions

3.3.1 INSTRUCTION CYCLE TIMES

The BX instruction takes $2S + 1N$ cycles to execute, where S and N are defined as sequential (S-cycle) and non-sequential (N-cycle), respectively.

3.3.2 ASSEMBLER SYNTAX

BX - branch and exchange.

BX {cond} Rn

{cond} Two character condition mnemonic. See Table 3-2.

Rn is an expression evaluating to a valid register number.

3.3.3 USING R15 AS AN OPERAND

If R15 is used as an operand, the behaviour is undefined.

Examples

```
ADR      R0, Into_THUMB + 1 ; Generate branch target address
; and set bit 0 high - hence
; arrive in THUMB state.
BX       R0 ; Branch and change to THUMB
; state.
CODE16 ; Assemble subsequent code as
Into_THUMB ; THUMB instructions
.
.
.
ADR R5, Back_to_ARM ; Generate branch target to word aligned address
; - hence bit 0 is low and so change back to ARM state.
BX R5 ; Branch and change back to ARM state.
.
.
.
ALIGN ; Word align
CODE32 ; Assemble subsequent code as ARM instructions
Back_to_ARM
```

3.4 BRANCH AND BRANCH WITH LINK (B, BL)

The instruction is only executed if the condition is true. The various conditions are defined Table 3-2. The instruction encoding is shown in Figure 3-3, below.

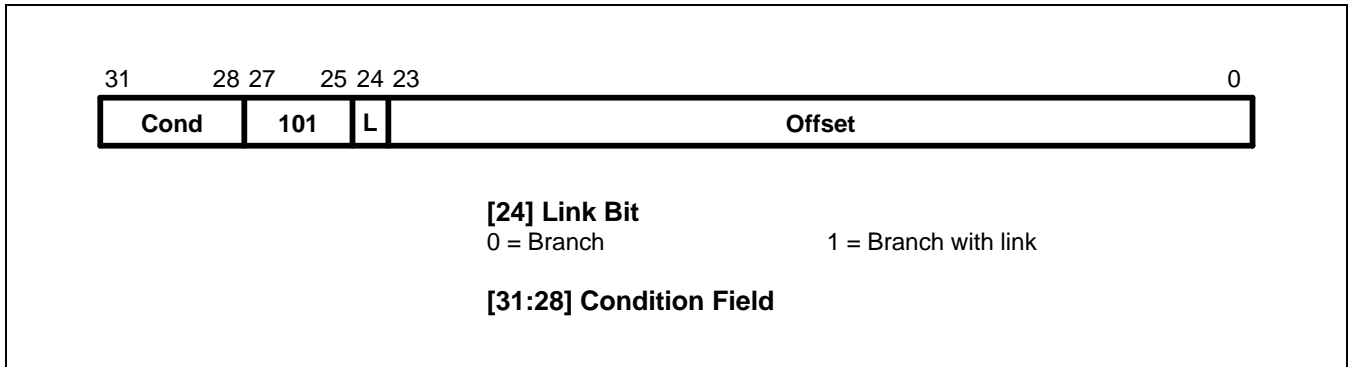

Figure 3-3. Branch Instructions

Branch instructions contain a signed 2's complement 24 bit offset. This is shifted left two bits, sign extended to 32 bits, and added to the PC. The instruction can therefore specify a branch of +/- 32Mbytes. The branch offset must take account of the pre-fetch operation, which causes the PC to be 2 words (8 bytes) ahead of the current instruction.

3.4.1 THE LINK BIT

Branch with Link (BL) writes the old PC into the link register (R14) of the current bank. The PC value written into R14 is adjusted to allow for the pre-fetch, and contains the address of the instruction following the branch and link instruction. Note that the CPSR is not saved with the PC and R14[1:0] are always cleared.

To return from a routine called by branch with link use MOV PC,R14 if the link register is still valid or LDM Rn!,{..PC} if the link register has been saved onto a stack pointed to by Rn.

3.4.2 INSTRUCTION CYCLE TIMES

Branch and branch with link instructions take $2S + 1N$ incremental cycles, where S and N are defined as sequential (S-cycle) and internal (I-cycle).

3.4.3 ASSEMBLER SYNTAX

Items in {} are optional. Items in < > must be present.

B{L}{cond} <expression>

{L} Used to request the branch with link form of the instruction. If absent, R14 will not be affected by the instruction.

{cond} A two-character mnemonic as shown in Table 3-2. If absent then AL (Always) will be used.

<expression> The destination. The assembler calculates the offset.

Examples

here	BAL	here	; Assembles to 0xEAFFFFF0 (note effect of PC offset).
	B	there	; Always condition used as default.
	CMP	R1,#0	; Compare R1 with zero and branch to fred
			; if R1 was zero, otherwise continue.
	BEQ	fred	; Continue to next instruction.
	BL	sub+ROM	; Call subroutine at computed address.
	ADDS	R1,#1	; Add 1 to register 1, setting CPSR flags
			; on the result then call subroutine if
	BLCC	sub	; the C flag is clear, which will be the
			; case unless R1 held 0xFFFFFFFF.

3.5 DATA PROCESSING

The data processing instruction is only executed if the condition is true. The conditions are defined in Table 3-2. The instruction encoding is shown in Figure 3-4.

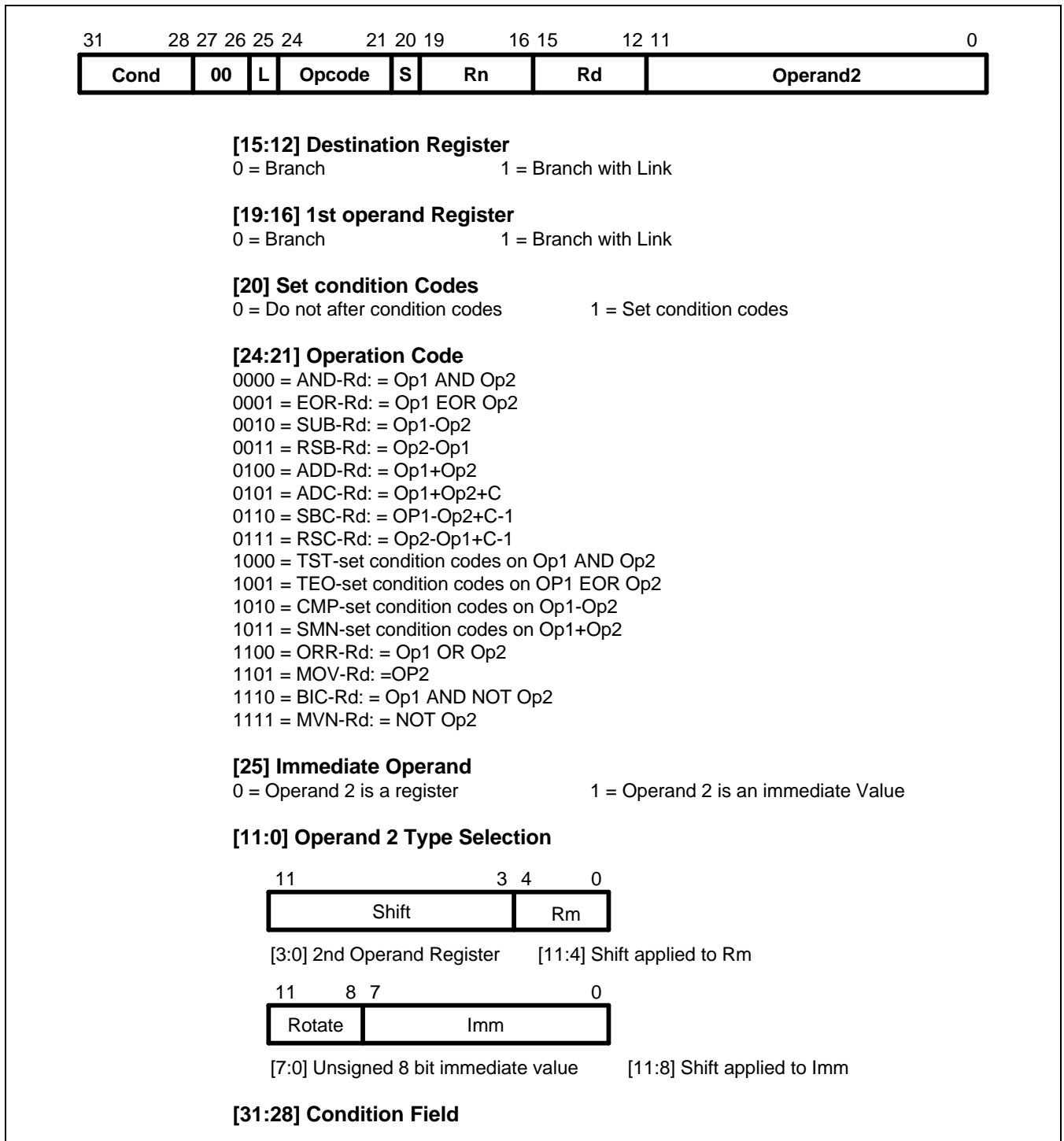

Figure 3-4. Data Processing Instructions

The instruction produces a result by performing a specified arithmetic or logical operation on one or two operands. The first operand is always a register (Rn).

The second operand may be a shifted register (Rm) or a rotated 8 bit immediate value (Imm) according to the value of the I bit in the instruction. The condition codes in the CPSR may be preserved or updated as a result of this instruction, according to the value of the S bit in the instruction.

Certain operations (TST, TEQ, CMP, CMN) do not write the result to Rd. They are used only to perform tests and to set the condition codes on the result and always have the S bit set. The instructions and their effects are listed in Table 3-3.

3.5.1 CPSR FLAGS

The data processing operations may be classified as logical or arithmetic. The logical operations (AND, EOR, TST, TEQ, ORR, MOV, BIC, MVN) perform the logical action on all corresponding bits of the operand or operands to produce the result. If the S bit is set (and Rd is not R15, see below) the V flag in the CPSR will be unaffected, the C flag will be set to the carry out from the barrel shifter (or preserved when the shift operation is LSL #0), the Z flag will be set if and only if the result is all zeros, and the N flag will be set to the logical value of bit 31 of the result.

Table 3-3. ARM Data Processing Instructions

Assembler Mnemonic	Opcode	Action
AND	0000	Operand1 AND operand2
EOR	0001	Operand1 EOR operand2
SUB	0010	Operand1 - operand2
RSB	0011	Operand2 - operand1
ADD	0100	Operand1 + operand2
ADC	0101	Operand1 + operand2 + carry
SBC	0110	Operand1 - operand2 + carry - 1
RSC	0111	Operand2 - operand1 + carry - 1
TST	1000	As AND, but result is not written
TEQ	1001	As EOR, but result is not written
CMP	1010	As SUB, but result is not written
CMN	1011	As ADD, but result is not written
ORR	1100	Operand1 OR operand2
MOV	1101	Operand2 (operand1 is ignored)
BIC	1110	Operand1 AND NOT operand2 (Bit clear)
MVN	1111	NOT operand2 (operand1 is ignored)

The arithmetic operations (SUB, RSB, ADD, ADC, SBC, RSC, CMP, CMN) treat each operand as a 32 bit integer (either unsigned or 2's complement signed, the two are equivalent). If the S bit is set (and Rd is not R15) the V flag in the CPSR will be set if an overflow occurs into bit 31 of the result; this may be ignored if the operands were considered unsigned, but warns of a possible error if the operands were 2's complement signed. The C flag will be set to the carry out of bit 31 of the ALU, the Z flag will be set if and only if the result was zero, and the N flag will be set to the value of bit 31 of the result (indicating a negative result if the operands are considered to be 2's complement signed).

3.5.2 SHIFTS

When the second operand is specified to be a shifted register, the operation of the barrel shifter is controlled by the shift field in the instruction. This field indicates the type of shift to be performed (logical left or right, arithmetic right or rotate right). The amount by which the register should be shifted may be contained in an immediate field in the instruction, or in the bottom byte of another register (other than R15). The encoding for the different shift types is shown in Figure 3-5.

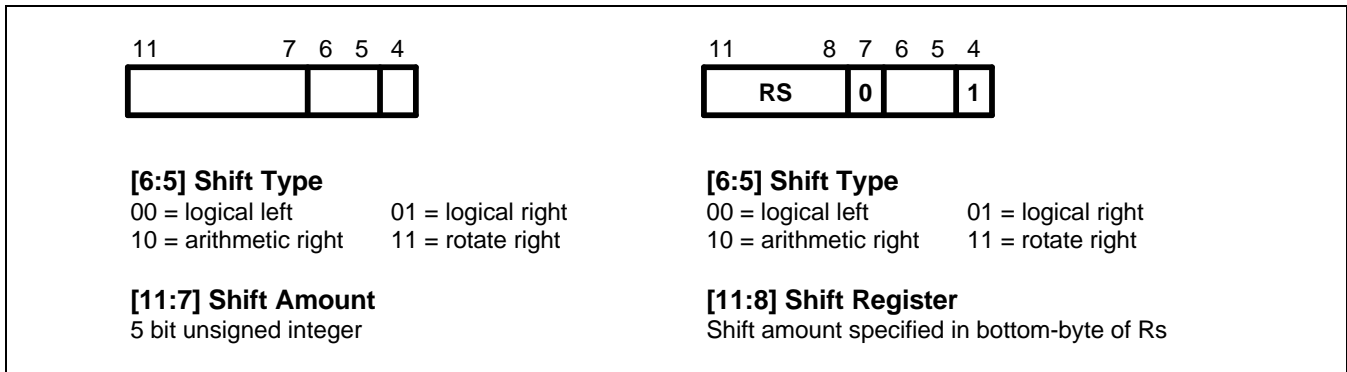

Figure 3-5. ARM Shift Operations

3.5.2.1 Instruction Specified Shift Amount

When the shift amount is specified in the instruction, it is contained in a 5 bit field which may take any value from 0 to 31. A logical shift left (LSL) takes the contents of Rm and moves each bit by the specified amount to a more significant position. The least significant bits of the result are filled with zeros, and the high bits of Rm which do not map into the result are discarded, except that the least significant discarded bit becomes the shifter carry output which may be latched into the C bit of the CPSR when the ALU operation is in the logical class (see above). For example, the effect of LSL #5 is shown in Figure 3-6.

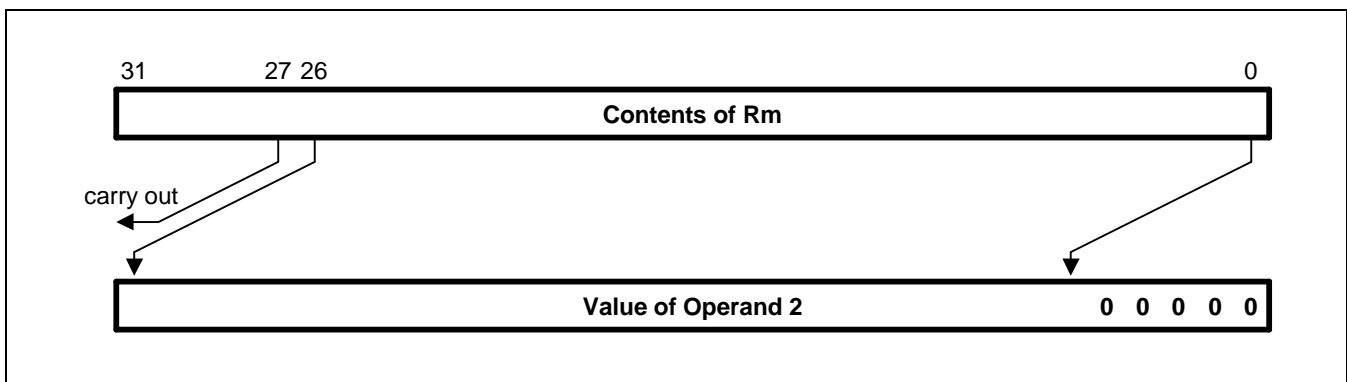

Figure 3-6. Logical Shift Left

NOTE

LSL #0 is a special case, where the shifter carry out is the old value of the CPSR C flag. The contents of Rm are used directly as the second operand. A logical shift right (LSR) is similar, but the contents of Rm are moved to less significant positions in the result. LSR #5 has the effect shown in Figure 3-7.

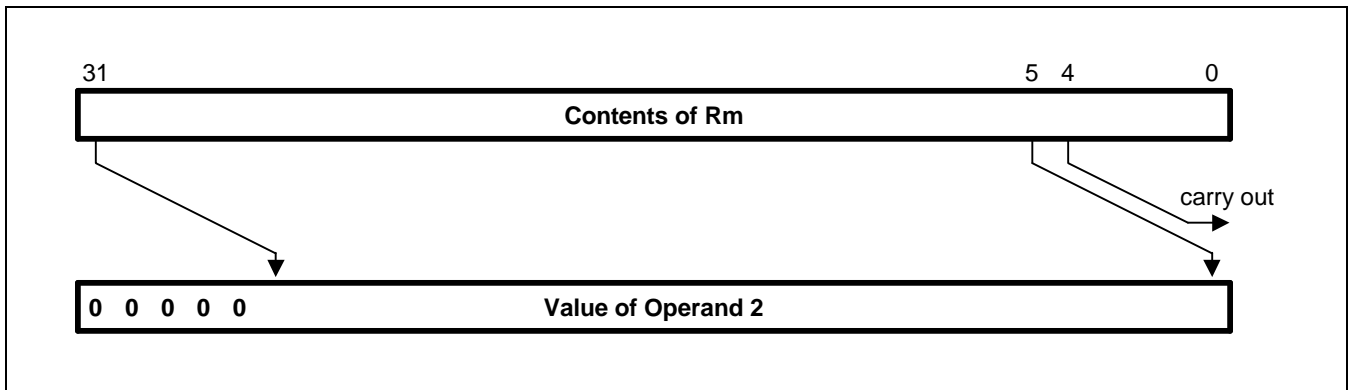

Figure 3-7. Logical Shift Right

The form of the shift field which might be expected to correspond to LSR #0 is used to encode LSR #32, which has a zero result with bit 31 of Rm as the carry output. Logical shift right zero is redundant as it is the same as logical shift left zero, so the assembler will convert LSR #0 (and ASR #0 and ROR #0) into LSL #0, and allow LSR #32 to be specified.

An arithmetic shift right (ASR) is similar to logical shift right, except that the high bits are filled with bit 31 of Rm instead of zeros. This preserves the sign in 2's complement notation. For example, ASR #5 is shown in Figure 3-8.

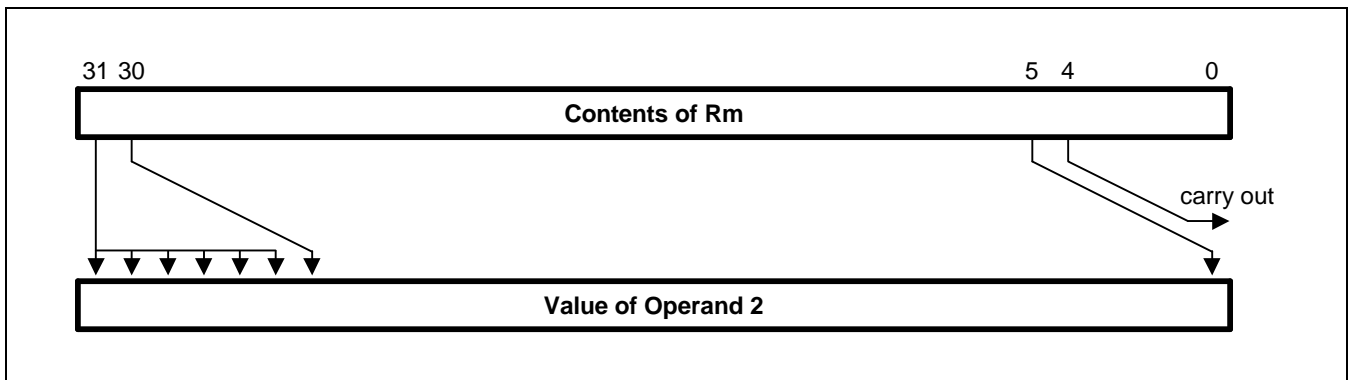

Figure 3-8. Arithmetic Shift Right

The form of the shift field which might be expected to give ASR #0 is used to encode ASR #32. Bit 31 of Rm is again used as the carry output, and each bit of operand 2 is also equal to bit 31 of Rm. The result is therefore all ones or all zeros, according to the value of bit 31 of Rm.

Rotate right (ROR) operations reuse the bits which overshoot in a logical shift right operation by reintroducing them at the high end of the result, in place of the zeros used to fill the high end in logical right operations. For example, ROR #5 is shown in Figure 3-9. The form of the shift field which might be expected to give ROR #0 is

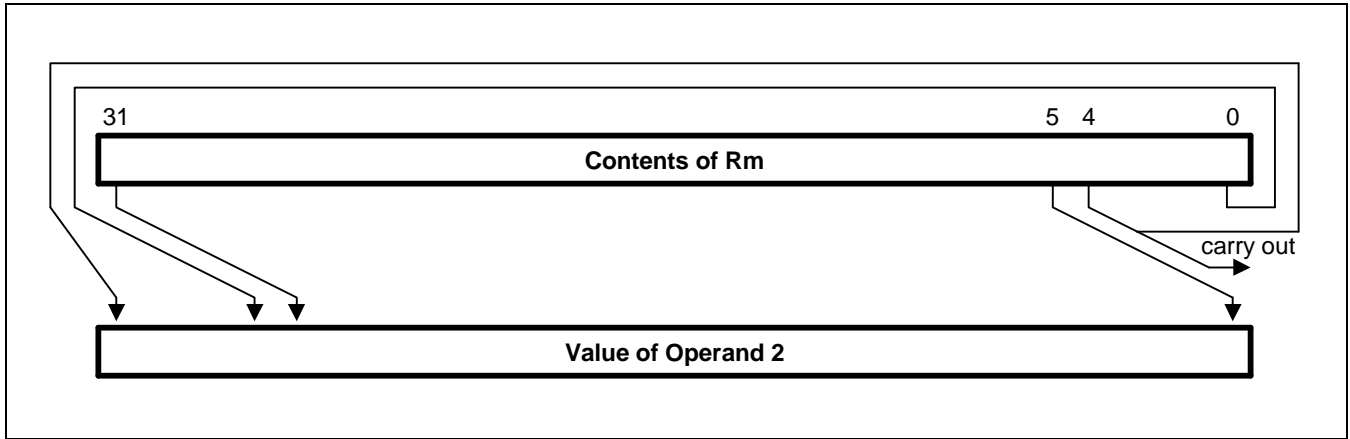

Figure 3-9. Rotate Right

used to encode a special function of the barrel shifter, rotate right extended (RRX). This is a rotate right by one bit position of the 33 bit quantity formed by appending the CPSR C flag to the most significant end of the contents of Rm as shown in Figure 3-10.

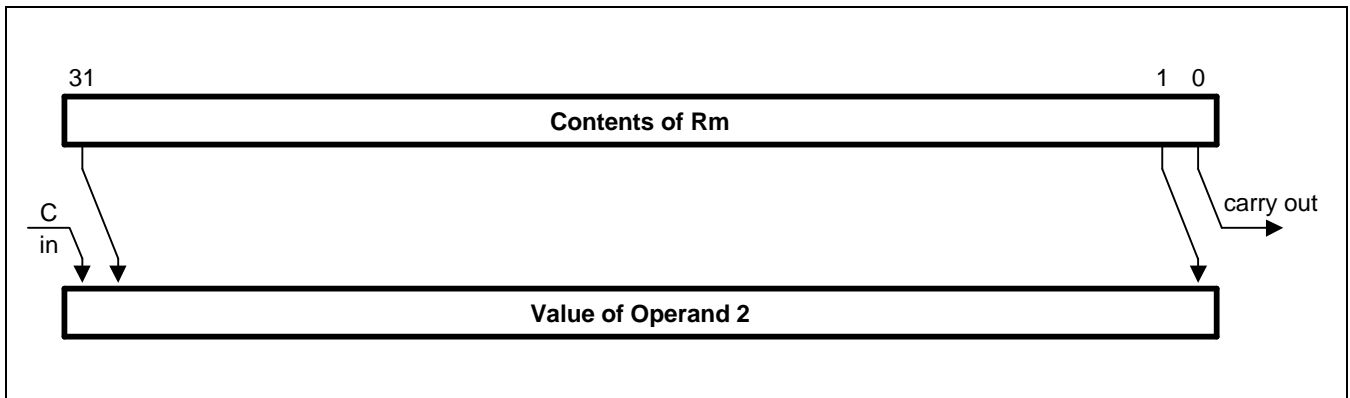

Figure 3-10. Rotate Right Extended

3.5.2.2 Register Specified Shift Amount

Only the least significant byte of the contents of Rs is used to determine the shift amount. Rs can be any general register other than R15.

If this byte is zero, the unchanged contents of Rm will be used as the second operand, and the old value of the CPSR C will be passed on as the shifter carry output.

If the byte has a value between 1 and 31, the shifted result will exactly match that of an instruction specified shift with the same value and shift operation.

If the value in the byte is 32 or more, the result will be a logical extension of the shift described above:

1. LSL by 32 has result zero, carry out equal to bit 0 of Rm.
2. LSL by more than 32 has result zero, carry out zero.
3. LSR by 32 has result zero, carry out equal to bit 31 of Rm.
4. LSR by more than 32 has result zero, carry out zero.
5. ASR by 32 or more has result filled with and carry out equal to bit 31 of Rm.
6. ROR by 32 has result equal to Rm, carry out equal to bit 31 of Rm.
7. ROR by n where n is greater than 32 will give the same result and carry out as ROR by n-32; therefore repeatedly subtract 32 from n until the amount is in the range 1 to 32 and see above.

NOTE

The zero in bit 7 of an instruction with a register controlled shift is compulsory; a one in this bit will cause the instruction to be a multiply or undefined instruction.

3.5.3 IMMEDIATE OPERAND ROTATES

The immediate operand rotate field is a 4 bit unsigned integer which specifies a shift operation on the 8 bit immediate value. This value is zero extended to 32 bits, and then subject to a rotate right by twice the value in the rotate field. This enables many common constants to be generated, for example all powers of 2.

3.5.4 WRITING TO R15

When Rd is a register other than R15, the condition code flags in the CPSR may be updated from the ALU flags as described above.

When Rd is R15 and the S flag in the instruction is not set the result of the operation is placed in R15 and the CPSR is unaffected.

When Rd is R15 and the S flag is set the result of the operation is placed in R15 and the SPSR corresponding to the current mode is moved to the CPSR. This allows state changes which atomically restore both PC and CPSR. This form of instruction should not be used in User mode.

3.5.5 USING R15 AS AN OPERAND

If R15 (the PC) is used as an operand in a data processing instruction the register is used directly.

The PC value will be the address of the instruction, plus 8 or 12 bytes due to instruction prefetching. If the shift amount is specified in the instruction, the PC will be 8 bytes ahead. If a register is used to specify the shift amount the PC will be 12 bytes ahead.

3.5.6 TEQ, TST, CMP AND CMN OPCODES

NOTE

TEQ, TST, CMP and CMN do not write the result of their operation but do set flags in the CPSR. An assembler should always set the S flag for these instructions even if this is not specified in the mnemonic.

The TEQP form of the TEQ instruction used in earlier ARM processors must not be used: the PSR transfer operations should be used instead.

The action of TEQP in the ARM9TDMI is to move SPSR_<mode> to the CPSR if the processor is in a privileged mode and to do nothing if in User mode.

3.5.7 INSTRUCTION CYCLE TIMES

Data processing instructions vary in the number of incremental cycles taken as follows:

Table 3-4. Incremental Cycle Times

Processing Type	Cycles
Normal data processing	1S
Data processing with register specified shift	1S + 1I
Data processing with PC written	2S + 1N
Data processing with register specified shift and PC written	2S + 1N + 1I

NOTE: S, N and I are as defined sequential (S-cycle), non-sequential (N-cycle), and internal (I-cycle) respectively.

3.6.8 ASSEMBLER SYNTAX

- MOV, MVN (single operand instructions).
<opcode>{cond}{S} Rd, <Op2>
- CMP, CMN, TEQ, TST (instructions which do not produce a result).
<opcode>{cond} Rn, <Op2>
- AND, EOR, SUB, RSB, ADD, ADC, SBC, RSC, ORR, BIC
<opcode>{cond}{S} Rd, Rn, <Op2>

where:

<Op2>	Rm{,<shift>} or, <#expression>
{cond}	A two-character condition mnemonic. See Table 3-2.
{S}	Set condition codes if S present (implied for CMP, CMN, TEQ, TST).
Rd, Rn and Rm	Expressions evaluating to a register number.
<#expression>	If this is used, the assembler will attempt to generate a shifted immediate 8-bit field to match the expression. If this is impossible, it will give an error.
<shift>	<Shiftname> <register> or <shiftname> #expression, or RRX (rotate right one bit with extend).
<shiftname>	ASL, LSL, LSR, ASR, ROR. (ASL is a synonym for LSL, they assemble to the same code.)

Examples

ADDEQ	R2,R4,R5	; If the Z flag is set make R2: = R4 + R5
TEQS	R4,#3	; Test R4 for equality with 3.
		; (The S is in fact redundant as the
		; assembler inserts it automatically.)
SUB	R4,R5,R7,LSR R2	; Logical right shift R7 by the number in
		; the bottom byte of R2, subtract result
		; from R5, and put the answer into R4.
MOV	PC,R14	; Return from subroutine.
MOVS	PC,R14	; Return from exception and restore CPSR
		; from SPSR_mode.

3.6 PSR TRANSFER (MRS, MSR)

The instruction is only executed if the condition is true. The various conditions are defined in Table 3-2.

The MRS and MSR instructions are formed from a subset of the data processing operations and are implemented using the TEQ, TST, CMN and CMP instructions without the S flag set. The encoding is shown in Figure 3-11.

These instructions allow access to the CPSR and SPSR registers. The MRS instruction allows the contents of the CPSR or SPSR_<mode> to be moved to a general register. The MSR instruction allows the contents of a general register to be moved to the CPSR or SPSR_<mode> register.

The MSR instruction also allows an immediate value or register contents to be transferred to the condition code flags (N,Z,C and V) of CPSR or SPSR_<mode> without affecting the control bits. In this case, the top four bits of the specified register contents or 32 bit immediate value are written to the top four bits of the relevant PSR.

3.6.1 OPERAND RESTRICTIONS

- In user mode, the control bits of the CPSR are protected from change, so only the condition code flags of the CPSR can be changed. In other (privileged) modes the entire CPSR can be changed.
- Note that the software must never change the state of the T bit in the CPSR. If this happens, the processor will enter an unpredictable state.
- The SPSR register which is accessed depends on the mode at the time of execution. For example, only SPSR_fiq is accessible when the processor is in FIQ mode.
- You must not specify R15 as the source or destination register.
- Also, do not attempt to access an SPSR in User mode, since no such register exists.

MRS (Transfer PSR Contents to a Register)

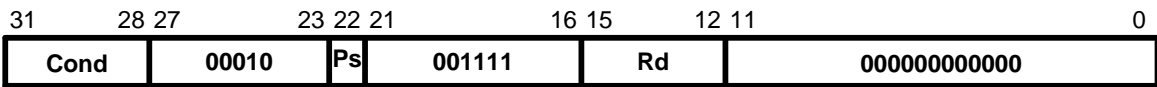

[15:21] Destination Register

[19:16] Source PSR

0 = CPSR 1 = SPSR_<current mode>

[31:28] Condition Field

MRS (Transfer Register Contents to PSR)

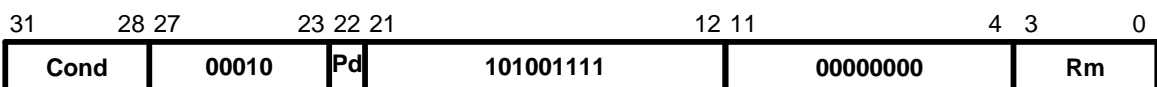

[3:0] Source Register

[22] Destination PSR

0 = CPSR 1 = SPSR_<current mode>

[31:28] Condition Field

MRS (Transfer Register Contents or Immediate Value to PSR Flag Bits Only)

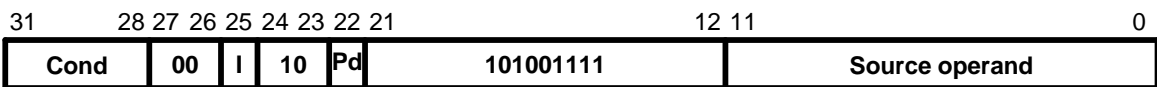

[22] Destination PSR

0 = CPSR 1 = SPSR_<current mode>

[25] Immediate Operand

0 = Source operand is a register

1 = SPSR_<current mode>

[11:0] Source Operand

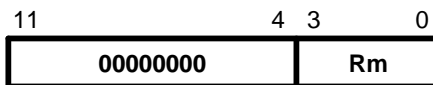

[3:0] Source Register

[11:4] Source operand is an immediate value

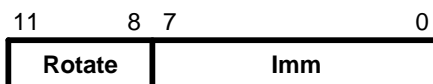

[7:0] Unsigned 8 bit immediate value

[11:8] Shift applied to Imm

[31:28] Condition Field

Figure 3-11. PSR Transfer

3.6.2 RESERVED BITS

Only twelve bits of the PSR are defined in ARM9TDMI (N, Z, C, V, I, F, T & M[4:0]); the remaining bits are reserved for use in future versions of the processor. Refer to Figure 2-6 for a full description of the PSR bits.

To ensure the maximum compatibility between ARM9TDMI programs and future processors, the following rules should be observed:

- The reserved bits should be preserved when changing the value in a PSR.
- Programs should not rely on specific values from the reserved bits when checking the PSR status, since they may read as one or zero in future processors.

A read-modify-write strategy should therefore be used when altering the control bits of any PSR register; this involves transferring the appropriate PSR register to a general register using the MRS instruction, changing only the relevant bits and then transferring the modified value back to the PSR register using the MSR instruction.

Examples

The following sequence performs a mode change:

```

MRS      R0,CPSR           ; Take a copy of the CPSR.
BIC      R0,R0,#0x1F      ; Clear the mode bits.
ORR      R0,R0,#new_mode  ; Select new mode
MSR      CPSR,R0          ; Write back the modified CPSR.

```

When the aim is simply to change the condition code flags in a PSR, a value can be written directly to the flag bits without disturbing the control bits. The following instruction sets the N, Z, C and V flags:

```

MSR      CPSR_flg,#0xF0000000 ; Set all the flags regardless of their previous state
                                           ; (does not affect any control bits).

```

No attempt should be made to write an 8 bit immediate value into the whole PSR since such an operation cannot preserve the reserved bits.

3.6.3 INSTRUCTION CYCLE TIMES

PSR transfers take 1S incremental cycles, where S is defined as sequential (S-cycle).

3.6.4 ASSEMBLER SYNTAX

- MRS - transfer PSR contents to a register
MRS{cond} Rd,<psr>
- MSR - transfer register contents to PSR
MSR{cond} <psr>,Rm
- MSR - transfer register contents to PSR flag bits only
MSR{cond} <psrf>,Rm

The most significant four bits of the register contents are written to the N,Z,C & V flags respectively.

- MSR - transfer immediate value to PSR flag bits only
MSR{cond} <psrf>, <#expression>

The expression should symbolise a 32 bit value of which the most significant four bits are written to the N, Z, C and V flags respectively.

Key:

{cond}	Two-character condition mnemonic. See Table 3-2.
Rd and Rm	Expressions evaluating to a register number other than R15
<psr>	CPSR, CPSR_all, SPSR or SPSR_all. (CPSR and CPSR_all are synonyms as are
SPSR	and SPSR_all)
<psrf>	CPSR_flg or SPSR_flg
<#expression>	Where this is used, the assembler will attempt to generate a shifted immediate 8-bit field to match the expression. If this is impossible, it will give an error.

Examples

In User mode the instructions behave as follows:

```

MSR    CPSR_all,Rm      ; CPSR[31:28] ← Rm[31:28]
MSR    CPSR_flg,Rm     ; CPSR[31:28] ← Rm[31:28]
MSR    CPSR_flg,#0xA0000000 ; CPSR[31:28] ← 0xA (set N, C; clear Z, V)
MRS    Rd,CPSR        ; Rd[31:0] ← CPSR[31:0]

```

In privileged modes the instructions behave as follows:

```

MSR    CPSR_all,Rm      ; CPSR[31:0] ← Rm[31:0]
MSR    CPSR_flg,Rm     ; CPSR[31:28] ← Rm[31:28]
MSR    CPSR_flg,#0x50000000 ; CPSR[31:28] ← 0x5 (set Z, V; clear N, C)
MSR    SPSR_all,Rm     ; SPSR_<mode>[31:0] ← Rm[31:0]
MSR    SPSR_flg,Rm     ; SPSR_<mode>[31:28] ← Rm[31:28]
MSR    SPSR_flg,#0xC0000000 ; SPSR_<mode>[31:28] ← 0xC (set N, Z; clear C, V)
MRS    Rd,SPSR        ; Rd[31:0] ← SPSR_<mode>[31:0]

```

3.7 MULTIPLY AND MULTIPLY-ACCUMULATE (MUL, MLA)

The instruction is only executed if the condition is true. The various conditions are defined in Table 3-2. The instruction encoding is shown in Figure 3-12.

The multiply and multiply-accumulate instructions use an 8 bit Booth's algorithm to perform integer multiplication.

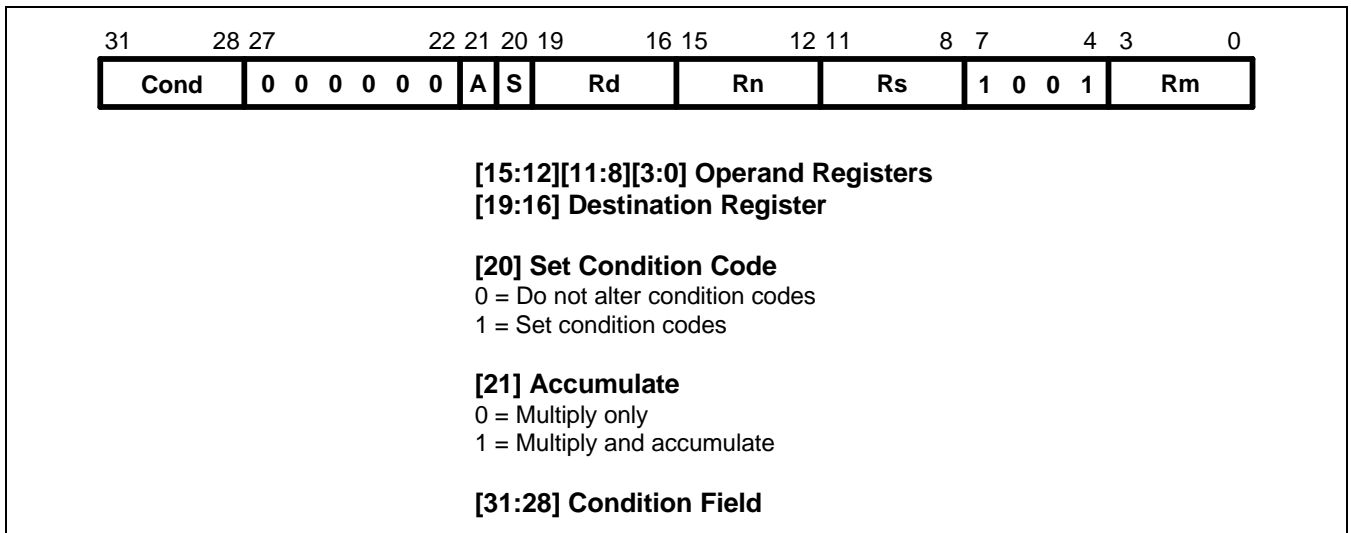

Figure 3-12. Multiply Instructions

The multiply form of the instruction gives $Rd = Rm * Rs$. Rn is ignored, and should be set to zero for compatibility with possible future upgrades to the instruction set. The multiply-accumulate form gives $Rd = Rm * Rs + Rn$, which can save an explicit ADD instruction in some circumstances. Both forms of the instruction work on operands which may be considered as signed (2' complement) or unsigned integers.

The results of a signed multiply and of an unsigned multiply of 32 bit operands differ only in the upper 32 bits-the low 32 bits of the signed and unsigned results are identical. As these instructions only produce the low 32 bits of a multiply, they can be used for both signed and unsigned multiplies.

For example consider the multiplication of the operands:

Operand A	Operand B	Result
0xFFFFFFFF6	0x0000001	0xFFFFFFFF38

If the Operands are Interpreted as Signed

Operand A has the value -10, operand B has the value 20, and the result is -200 which is correctly represented as 0xFFFFFFFF38.

If the Operands are Interpreted as Unsigned

Operand A has the value 4294967286, operand B has the value 20 and the result is 85899345720, which is represented as 0x13FFFFFF38, so the least significant 32 bits are 0xFFFFFFFF38.

Operand Restrictions

The destination register Rd must not be the same as the operand register Rm . $R15$ must not be used as an operand or as the destination register.

All other register combinations will give correct results, and Rd , Rn and Rs may use the same register when required.

3.7.1 CPSR FLAGS

Setting the CPSR flags is optional, and is controlled by the S bit in the instruction. The N (Negative) and Z (Zero) flags are set correctly on the result (N is made equal to bit 31 of the result, and Z is set if and only if the result is zero). The C (Carry) flag is set to a meaningless value and the V (overflow) flag is unaffected.

3.7.2 INSTRUCTION CYCLE TIMES

MUL takes $1S + mI$ and MLA $1S + (m+1)I$ cycles to execute, where S and I are defined as sequential (S-cycle) and internal (I-cycle), respectively.

m	The number of 8 bit multiplier array cycles is required to complete the multiply, which is controlled by the value of the multiplier operand specified by Rs. Its possible values are as follows
1	If bits [32:8] of the multiplier operand are all zero or all one.
2	If bits [32:16] of the multiplier operand are all zero or all one.
3	If bits [32:24] of the multiplier operand are all zero or all one.
4	In all other cases.

3.7.3 ASSEMBLER SYNTAX

MUL{cond}{S} Rd,Rm,Rs
MLA{cond}{S} Rd,Rm,Rs,Rn

{cond}	Two-character condition mnemonic. See Table 3-2.
{S}	Set condition codes if S present
Rd, Rm, Rs and Rn	Expressions evaluating to a register number other than R15.

Examples

```
MUL      R1,R2,R3      ; R1: = R2 * R3
MLAEQS   R1,R2,R3,R4   ; Conditionally R1: = R2 * R3 + R4, setting condition
                        ; codes.
```

3.8 MULTIPLY LONG AND MULTIPLY-ACCUMULATE LONG (MULL,MLAL)

The instruction is only executed if the condition is true. The various conditions are defined in Table 3-2. The instruction encoding is shown in Figure 3-13.

The multiply long instructions perform integer multiplication on two 32 bit operands and produce 64 bit results. Signed and unsigned multiplication each with optional accumulate give rise to four variations.

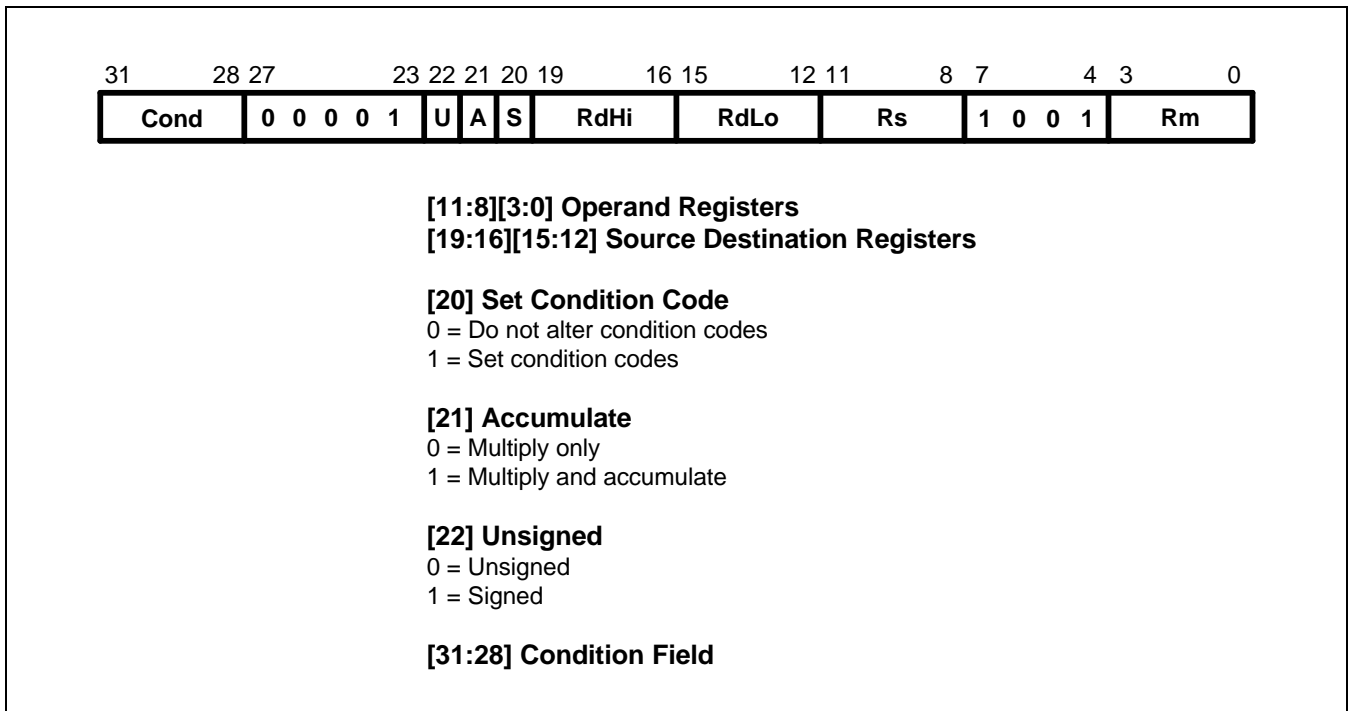

Figure 3-13. Multiply Long Instructions

The multiply forms (UMULL and SMULL) take two 32 bit numbers and multiply them to produce a 64 bit result of the form RdHi, RdLo: = Rm * Rs. The lower 32 bits of the 64 bit result are written to RdLo, the upper 32 bits of the result are written to RdHi.

The multiply-accumulate forms (UMLAL and SMLAL) take two 32 bit numbers, multiply them and add a 64 bit number to produce a 64 bit result of the form RdHi, RdLo: = Rm * Rs + RdHi, RdLo. The lower 32 bits of the 64 bit number to add is read from RdLo. The upper 32 bits of the 64 bit number to add is read from RdHi. The lower 32 bits of the 64 bit result are written to RdLo. The upper 32 bits of the 64 bit result are written to RdHi.

The UMULL and UMLAL instructions treat all of their operands as unsigned binary numbers and write an unsigned 64 bit result. The SMULL and SMLAL instructions treat all of their operands as two's-complement signed numbers and write a two's-complement signed 64 bit result.

3.8.1 OPERAND RESTRICTIONS

- R15 must not be used as an operand or as a destination register.
- RdHi, RdLo, and Rm must all specify different registers.

3.8.2 CPSR FLAGS

Setting the CPSR flags is optional, and is controlled by the S bit in the instruction. The N and Z flags are set correctly on the result (N is equal to bit 63 of the result, Z is set if and only if all 64 bits of the result are zero). Both the C and V flags are set to meaningless values.

3.8.3 INSTRUCTION CYCLE TIMES

MULL takes $1S + (m+1)I$ and MLAL $1S + (m+2)I$ cycles to execute, where m is the number of 8 bit multiplier array cycles required to complete the multiply, which is controlled by the value of the multiplier operand specified by Rs.

Its possible values are as follows:

For Signed Instructions SMULL, SMLAL:

- If bits [31:8] of the multiplier operand are all zero or all one.
- If bits [31:16] of the multiplier operand are all zero or all one.
- If bits [31:24] of the multiplier operand are all zero or all one.
- In all other cases.

For Unsigned Instructions UMULL, UMLAL:

- If bits [31:8] of the multiplier operand are all zero.
- If bits [31:16] of the multiplier operand are all zero.
- If bits [31:24] of the multiplier operand are all zero.
- In all other cases.

S and I are defined as sequential (S-cycle) and internal (I-cycle), respectively.

3.8.4 ASSEMBLER SYNTAX

Table 3-5. Assembler Syntax Descriptions

Mnemonic	Description	Purpose
UMULL{cond}{S} RdLo, RdHi, Rm, Rs	Unsigned multiply long	$32 \times 32 = 64$
UMLAL{cond}{S} RdLo, RdHi, Rm, Rs	Unsigned multiply & Accumulate long	$32 \times 32 + 64 = 64$
SMULL{cond}{S} RdLo, RdHi, Rm, Rs	Signed multiply long	$32 \times 32 = 64$
SMLAL{cond}{S} RdLo, RdHi, Rm, Rs	Signed multiply & Accumulate long	$32 \times 32 + 64 = 64$

where:

{cond} Two-character condition mnemonic. See Table 3-2.
 {S} Set condition codes if S present
 RdLo, RdHi, Rm, Rs Expressions evaluating to a register number other than R15.

Examples

```
UMULL    R1, R4, R2, R3    ; R4, R1: = R2 * R3
UMLALS   R1, R5, R2, R3    ; R5, R1: = R2 * R3 + R5, R1 also setting condition codes
```

3.9 SINGLE DATA TRANSFER (LDR, STR)

The instruction is only executed if the condition is true. The various conditions are defined in Table 3-2. The instruction encoding is shown in Figure 3-14.

The single data transfer instructions are used to load or store single bytes or words of data. The memory address used in the transfer is calculated by adding an offset to or subtracting an offset from a base register.

The result of this calculation may be written back into the base register if auto-indexing is required.

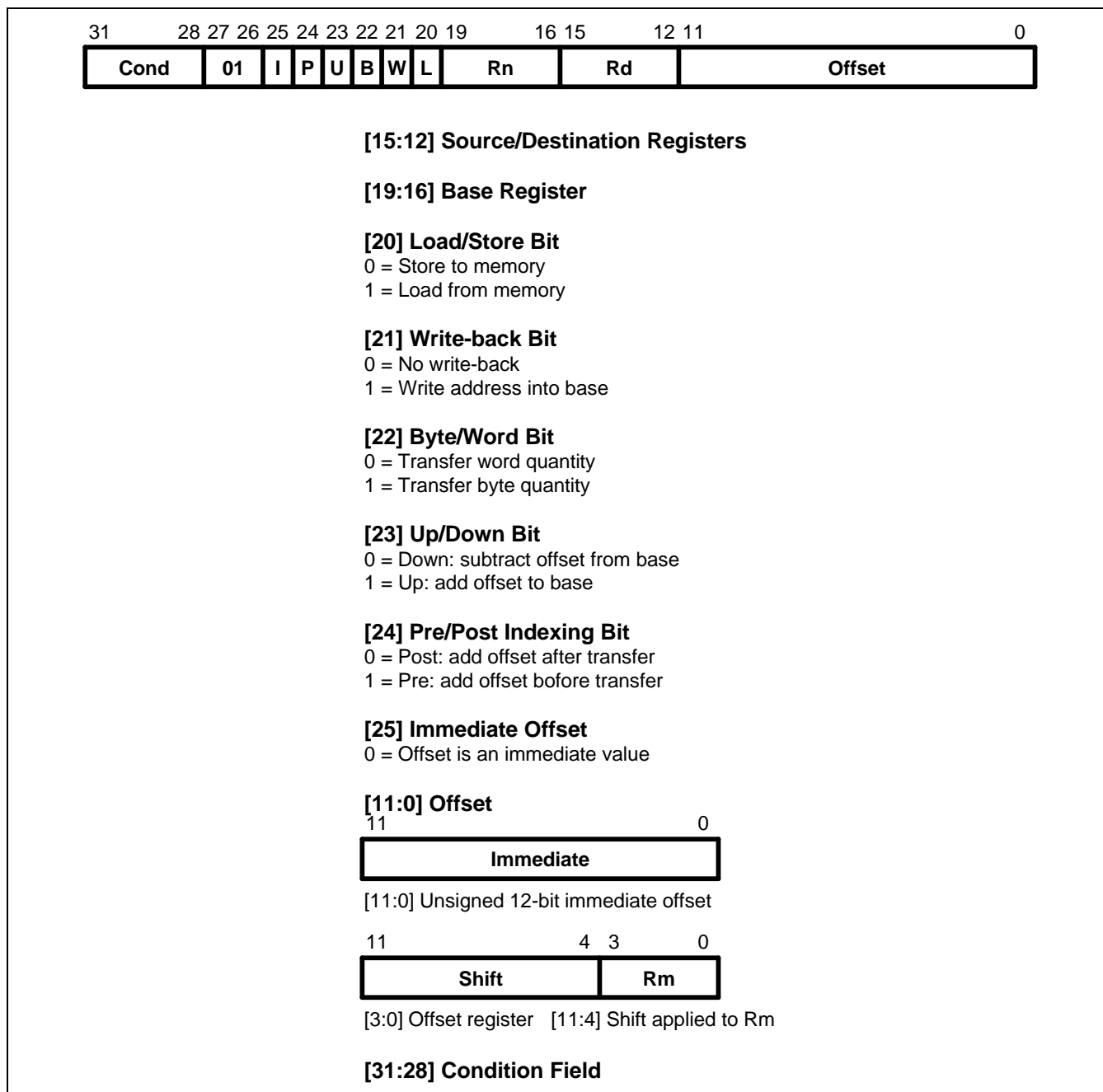

Figure 3-14. Single Data Transfer Instructions

3.9.1 OFFSETS AND AUTO-INDEXING

The offset from the base may be either a 12 bit unsigned binary immediate value in the instruction, or a second register (possibly shifted in some way). The offset may be added to ($U = 1$) or subtracted from ($U = 0$) the base register R_n . The offset modification may be performed either before (pre-indexed, $P = 1$) or after (post-indexed, $P = 0$) the base is used as the transfer address.

The W bit gives optional auto increment and decrement addressing modes. The modified base value may be written back into the base ($W = 1$), or the old base value may be kept ($W = 0$). In the case of post-indexed addressing, the write back bit is redundant and is always set to zero, since the old base value can be retained by setting the offset to zero. Therefore post-indexed data transfers always write back the modified base. The only use of the W bit in a post-indexed data transfer is in privileged mode code, where setting the W bit forces non-privileged mode for the transfer, allowing the operating system to generate a user address in a system where the memory management hardware makes suitable use of this hardware.

3.9.2 SHIFTED REGISTER OFFSET

The 8 shift control bits are described in the data processing instructions section. However, the register specified shift amounts are not available in this instruction class. See Figure 3-5.

3.9.3 BYTES AND WORDS

This instruction class may be used to transfer a byte ($B = 1$) or a word ($B = 0$) between an ARM9TDMI register and memory.

The action of LDR(B) and STR(B) instructions is influenced by the BIGEND control signal of ARM9TDMI core. The two possible configurations are described below.

3.9.3.1 Little-Endian Configuration

A byte load (LDRB) expects the data on data bus inputs 7 through 0 if the supplied address is on a word boundary, on data bus inputs 15 through 8 if it is a word address plus one byte, and so on. The selected byte is placed in the bottom 8 bits of the destination register, and the remaining bits of the register are filled with zeros. Please see Figure 2-2.

A byte store (STRB) repeats the bottom 8 bits of the source register four times across data bus outputs 31 through 0. The external memory system should activate the appropriate byte subsystem to store the data.

A word load (LDR) will normally use a word aligned address. However, an address offset from a word boundary will cause the data to be rotated into the register so that the addressed byte occupies bits 0 to 7. This means that half-words accessed at offsets 0 and 2 from the word boundary will be correctly loaded into bits 0 through 15 of the register. Two shift operations are then required to clear or to sign extend the upper 16 bits.

A word store (STR) should generate a word aligned address. The word presented to the data bus is not affected if the address is not word aligned. That is, bit 31 of the register being stored always appears on data bus output 31.

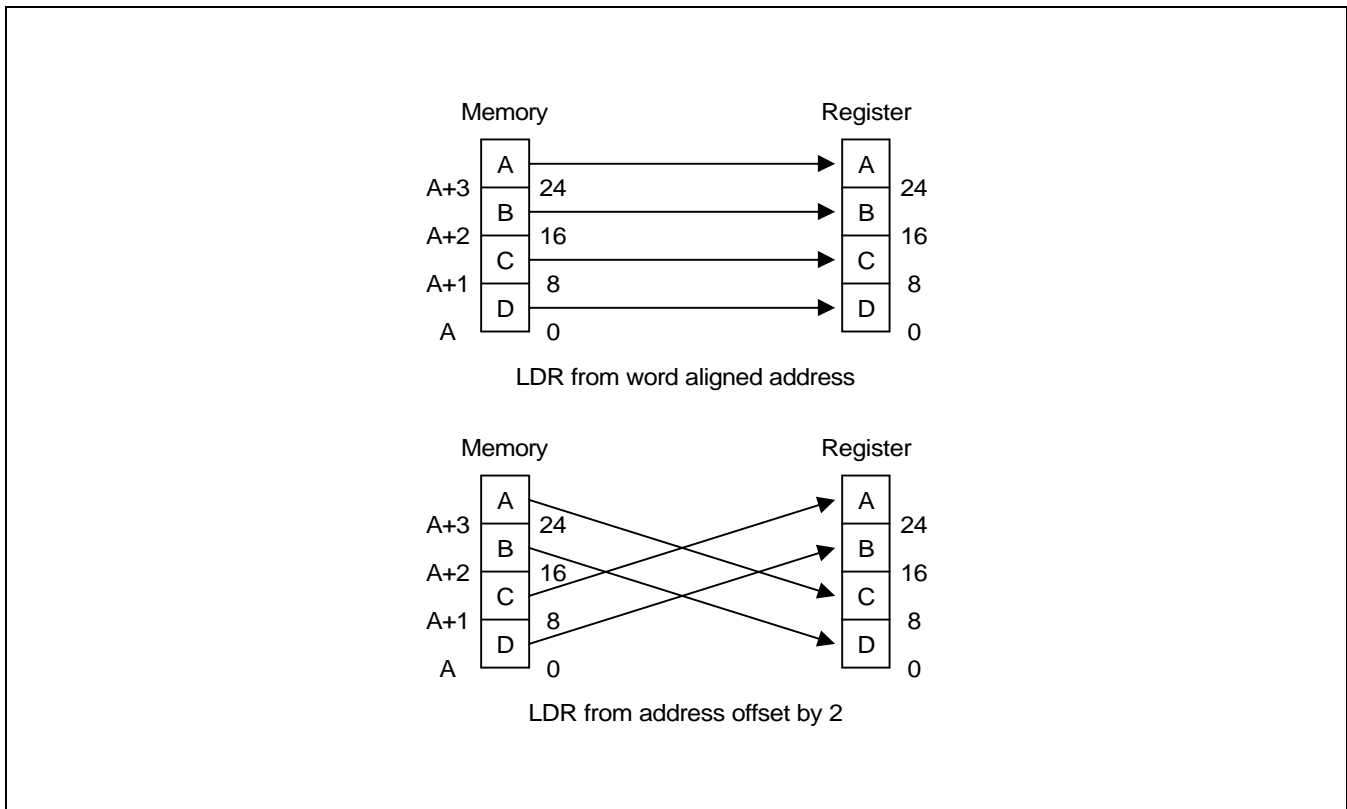

Figure 3-15. Little-Endian Offset Addressing

3.9.3.2 Big-Endian Configuration

A byte load (LDRB) expects the data on data bus inputs 31 through 24 if the supplied address is on a word boundary, on data bus inputs 23 through 16 if it is a word address plus one byte, and so on. The selected byte is placed in the bottom 8 bits of the destination register and the remaining bits of the register are filled with zeros. Please see Figure 2-1.

A byte store (STRB) repeats the bottom 8 bits of the source register four times across data bus outputs 31 through 0. The external memory system should activate the appropriate byte subsystem to store the data.

A word load (LDR) should generate a word aligned address. An address offset of 0 or 2 from a word boundary will cause the data to be rotated into the register so that the addressed byte occupies bits 31 through 24. This means that half-words accessed at these offsets will be correctly loaded into bits 16 through 31 of the register. A shift operation is then required to move (and optionally sign extend) the data into the bottom 16 bits. An address offset of 1 or 3 from a word boundary will cause the data to be rotated into the register so that the addressed byte occupies bits 15 through 8.

A word store (STR) should generate a word aligned address. The word presented to the data bus is not affected if the address is not word aligned. That is, bit 31 of the register being stored always appears on data bus output 31.

3.9.4 USE OF R15

Write-back must not be specified if R15 is specified as the base register (Rn). When using R15 as the base register you must remember it contains an address 8 bytes on from the address of the current instruction.

R15 must not be specified as the register offset (Rm).

When R15 is the source register (Rd) of a register store (STR) instruction, the stored value will be address of the instruction plus 12.

3.9.5 RESTRICTION ON THE USE OF BASE REGISTER

When configured for late aborts, the following example code is difficult to unwind as the base register, Rn, gets updated before the abort handler starts. Sometimes it may be impossible to calculate the initial value.

After an abort, the following example code is difficult to unwind as the base register, Rn, gets updated before the abort handler starts. Sometimes it may be impossible to calculate the initial value.

Example:

```
LDR      R0,[R1],R1
```

Therefore a post-indexed LDR or STR where Rm is the same register as Rn should not be used.

3.9.6 DATA ABORTS

A transfer to or from a legal address may cause problems for a memory management system. For instance, in a system which uses virtual memory the required data may be absent from main memory. The memory manager can signal a problem by taking the processor ABORT input HIGH whereupon the data abort trap will be taken. It is up to the system software to resolve the cause of the problem, then the instruction can be restarted and the original program continued.

3.9.7 INSTRUCTION CYCLE TIMES

Normal LDR instructions take $1S + 1N + 1I$ and LDR PC take $2S + 2N + 1I$ incremental cycles, where S,N and I are defined as sequential (S-cycle), non-sequential (N-cycle), and internal (I-cycle), respectively. STR instructions take $2N$ incremental cycles to execute.

3.9.8 ASSEMBLER SYNTAX

<LDR|STR>{cond}{B}{T} Rd,<Address>

where:

LDR	Load from memory into a register
STR	Store from a register into memory
{cond}	Two-character condition mnemonic. See Table 3-2.
{B}	If B is present then byte transfer, otherwise word transfer
{T}	If T is present the W bit will be set in a post-indexed instruction, forcing non-privileged mode for the transfer cycle. T is not allowed when a pre-indexed addressing mode is specified or implied.
Rd	An expression evaluating to a valid register number.
Rn and Rm	Expressions evaluating to a register number. If Rn is R15 then the assembler will subtract 8 from the offset value to allow for ARM9TDMI pipelining. In this case base write-back should not be specified.

<Address>can be:

1	An expression which generates an address: The assembler will attempt to generate an instruction using the PC as a base and a corrected immediate offset to address the location given by evaluating the expression. This will be a PC relative, pre-indexed address. If the address is out of range, an error will be generated.
2	A pre-indexed addressing specification: [Rn] offset of zero [Rn,<#expression>]{!} offset of <expression> bytes [Rn,{+/-}Rm{,<shift>}]{} offset of +/- contents of index register, shifted by <shift>
3	A post-indexed addressing specification: [Rn,<#expression>] offset of <expression> bytes [Rn,{+/-}Rm{,<shift>}] offset of +/- contents of index register, shifted as by <shift>.
<shift>	General shift operation (see data processing instructions) but you cannot specify the shift amount by a register.
{!}	Writes back the base register (set the W bit) if ! is present.

Examples

STR	R1,[R2,R4]!	; Store R1 at R2 + R4 (both of which are registers)
		; and write back address to R2.
STR	R1,[R2],R4	; Store R1 at R2 and write back R2 + R4 to R2.
LDR	R1,[R2,#16]	; Load R1 from contents of R2 + 16, but don't write back.
LDR	R1,[R2,R3,LSL#2]	; Load R1 from contents of R2 + R3 * 4.
LDREQB	R1,[R6,#5]	; Conditionally load byte at R6 + 5 into
		; R1 bits 0 to 7, filling bits 8 to 31 with zeros.
STR	R1,PLACE	; Generate PC relative offset to address PLACE.
PLACE		

3.10 HALFWORD AND SIGNED DATA TRANSFER (LDRH/STRH/LDRSB/LDRSH)

The instruction is only executed if the condition is true. The various conditions are defined in Table 3-2. The instruction encoding is shown in Figure 3-16.

These instructions are used to load or store half-words of data and also load sign-extended bytes or half-words of data. The memory address used in the transfer is calculated by adding an offset to or subtracting an offset from a base register. The result of this calculation may be written back into the base register if auto-indexing is required.

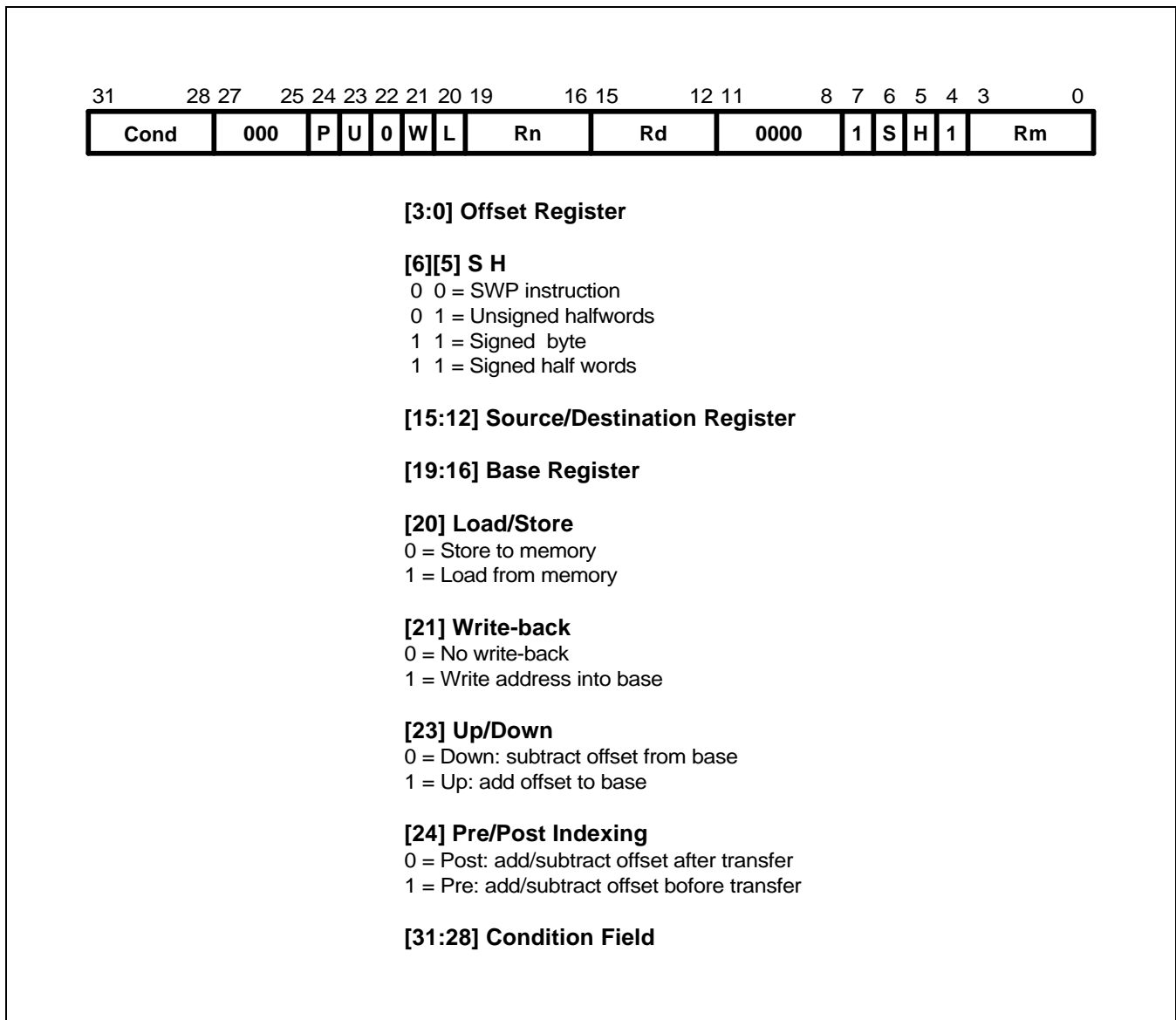

Figure 3-16. Half-word and Signed Data Transfer with Register Offset

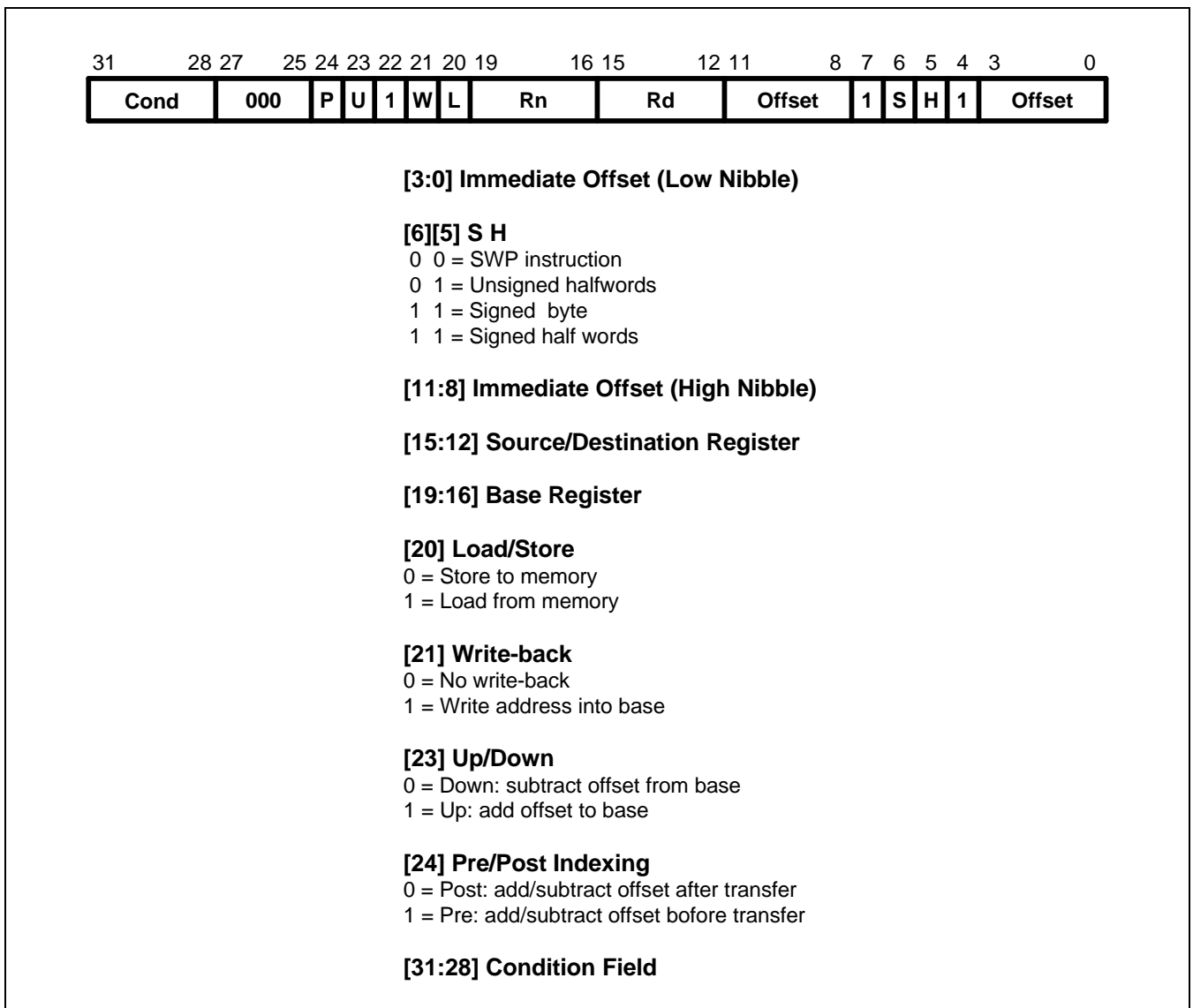

Figure 3-17. Half-word and Signed Data Transfer with Immediate Offset and Auto-Indexing

3.10.1 OFFSETS AND AUTO-INDEXING

The offset from the base may be either a 8-bit unsigned binary immediate value in the instruction, or a second register. The 8-bit offset is formed by concatenating bits 11 to 8 and bits 3 to 0 of the instruction word, such that bit 11 becomes the MSB and bit 0 becomes the LSB. The offset may be added to (U = 1) or subtracted from (U = 0) the base register Rn. The offset modification may be performed either before (pre-indexed, P = 1) or after (post-indexed, P = 0) the base register is used as the transfer address.

The W bit gives optional auto-increment and decrement addressing modes. The modified base value may be written back into the base (W = 1), or the old base may be kept (W = 0). In the case of post-indexed addressing, the write back bit is redundant and is always set to zero, since the old base value can be retained if necessary by setting the offset to zero. Therefore post-indexed data transfers always write back the modified base.

The Write-back bit should not be set high (W = 1) when post-indexed addressing is selected.

3.10.2 HALF-WORD LOAD AND STORES

Setting S = 0 and H = 1 may be used to transfer unsigned Half-words between an ARM9TDMI register and memory.

The action of LDRH and STRH instructions is influenced by the BIGEND control signal. The two possible configurations are described in the section below.

3.10.3 SIGNED BYTE AND HALF-WORD LOADS

The S bit controls the loading of sign-extended data. When S = 1 the H bit selects between Bytes (H = 0) and Half-words (H = 1). The L bit should not be set low (Store) when Signed (S = 1) operations have been selected.

The LDRSB instruction loads the selected Byte into bits 7 to 0 of the destination register and bits 31 to 8 of the destination register are set to the value of bit 7, the sign bit.

The LDRSH instruction loads the selected Half-word into bits 15 to 0 of the destination register and bits 31 to 16 of the destination register are set to the value of bit 15, the sign bit.

The action of the LDRSB and LDRSH instructions is influenced by the BIGEND control signal. The two possible configurations are described in the following section.

3.10.4 ENDIANNESS AND BYTE/HALF-WORD SELECTION

3.10.4.1 Little-Endian Configuration

A signed byte load (LDRSB) expects data on data bus inputs 7 through to 0 if the supplied address is on a word boundary, on data bus inputs 15 through to 8 if it is a word address plus one byte, and so on. The selected byte is placed in the bottom 8 bit of the destination register, and the remaining bits of the register are filled with the sign bit, bit 7 of the byte. Please see Figure 2-2.

A half-word load (LDRSH or LDRH) expects data on data bus inputs 15 through to 0 if the supplied address is on a word boundary and on data bus inputs 31 through to 16 if it is a half-word boundary, (A[1]=1). The supplied address should always be on a half-word boundary. If bit 0 of the supplied address is high then the ARM9TDMI will load an unpredictable value. The selected half-word is placed in the bottom 16 bits of the destination register. For unsigned half-words (LDRH), the top 16 bits of the register are filled with zeros and for signed half-words (LDRSH) the top 16 bits are filled with the sign bit, bit 15 of the half-word.

A half-word store (STRH) repeats the bottom 16 bits of the source register twice across the data bus outputs 31 through to 0. The external memory system should activate the appropriate half-word subsystem to store the data. Note that the address must be half-word aligned, if bit 0 of the address is high this will cause unpredictable behaviour.

3.10.4.2 Big-Endian Configuration

A signed byte load (LDRSB) expects data on data bus inputs 31 through to 24 if the supplied address is on a word boundary, on data bus inputs 23 through to 16 if it is a word address plus one byte, and so on. The selected byte is placed in the bottom 8 bit of the destination register, and the remaining bits of the register are filled with the sign bit, bit 7 of the byte. Please see Figure 2-1.

A half-word load (LDRSH or LDRH) expects data on data bus inputs 31 through to 16 if the supplied address is on a word boundary and on data bus inputs 15 through to 0 if it is a half-word boundary, ($A[1] = 1$). The supplied address should always be on a half-word boundary. If bit 0 of the supplied address is high then the ARM9TDMI will load an unpredictable value. The selected half-word is placed in the bottom 16 bits of the destination register. For unsigned half-words (LDRH), the top 16 bits of the register are filled with zeros and for signed half-words (LDRSH) the top 16 bits are filled with the sign bit, bit 15 of the half-word.

A half-word store (STRH) repeats the bottom 16 bits of the source register twice across the data bus outputs 31 through to 0. The external memory system should activate the appropriate half-word subsystem to store the data. Note that the address must be half-word aligned, if bit 0 of the address is HIGH this will cause unpredictable behaviour.

3.10.5 USE OF R15

Write-back should not be specified if R15 is specified as the base register (R_n). When using R15 as the base register you must remember it contains an address 8 bytes on from the address of the current instruction.

R15 should not be specified as the register offset (R_m).

When R15 is the source register (R_d) of a Half-word store (STRH) instruction, the stored address will be address of the instruction plus 12.

3.10.6 DATA ABORTS

A transfer to or from a legal address may cause problems for a memory management system. For instance, in a system which uses virtual memory the required data may be absent from the main memory. The memory manager can signal a problem by taking the processor ABORT input high whereupon the data abort trap will be taken. It is up to the system software to resolve the cause of the problem, then the instruction can be restarted and the original program continued.

3.10.7 INSTRUCTION CYCLE TIMES

Normal LDR(H, SH, SB) instructions take $1S + 1N + 1I$. LDR(H, SH, SB) PC take $2S + 2N + 1I$ incremental cycles. S, N and I are defined as sequential (S-cycle), non-sequential (N-cycle), and internal (I-cycle), respectively. STRH instructions take $2N$ incremental cycles to execute.

3.10.8 ASSEMBLER SYNTAX

<LDR|STR>{cond}<H|SH|SB> Rd,<address>

LDR	Load from memory into a register
STR	Store from a register into memory
{cond}	Two-character condition mnemonic. See Table 3-2.
H	Transfer half-word quantity
SB	Load sign extended byte (Only valid for LDR)
SH	Load sign extended half-word (Only valid for LDR)
Rd	An expression evaluating to a valid register number.

<address> can be:

- 1 An expression which generates an address:
The assembler will attempt to generate an instruction using the PC as a base and a corrected immediate offset to address the location given by evaluating the expression. This will be a PC relative, pre-indexed address. If the address is out of range, an error will be generated.
- 2 A pre-indexed addressing specification:

[Rn]	offset of zero
[Rn,<#expression>]{!}	offset of <expression> bytes
[Rn,{+/-}Rm]{!}	offset of +/- contents of index register
- 3 A post-indexed addressing specification:

[Rn],<#expression>	offset of <expression> bytes
[Rn],{+/-}Rm	offset of +/- contents of index register.
- 4 Rn and Rm are expressions evaluating to a register number. If Rn is R15 then the assembler will subtract 8 from the offset value to allow for ARM9TDMI pipelining. In this case base write-back should not be specified.
- {!} Writes back the base register (set the W bit) if ! is present.

Examples

LDRH	R1,[R2,-R3]!	; Load R1 from the contents of the half-word address ; contained in R2-R3 (both of which are registers) ; and write back address to R2
STRH	R3,[R4,#14]	; Store the half-word in R3 at R14+14 but don't write back.
LDRSB	R8,[R2],#-223	; Load R8 with the sign extended contents of the byte ; address contained in R2 and write back R2-223 to R2.
LDRNESH	R11,[R0]	; Conditionally load R11 with the sign extended contents ; of the half-word address contained in R0.
HERE		; Generate PC relative offset to address FRED.
STRH	R5, [PC,#(FRED-HERE-8)];	Store the half-word in R5 at address FRED
FRED		

3.11 BLOCK DATA TRANSFER (LDM, STM)

The instruction is only executed if the condition is true. The various conditions are defined in Table 3-2. The instruction encoding is shown in Figure 3-18.

Block data transfer instructions are used to load (LDM) or store (STM) any subset of the currently visible registers. They support all possible stacking modes, maintaining full or empty stacks which can grow up or down memory, and are very efficient instructions for saving or restoring context, or for moving large blocks of data around main memory.

3.11.1 THE REGISTER LIST

The instruction can cause the transfer of any registers in the current bank (and non-user mode programs can also transfer to and from the user bank, see below). The register list is a 16 bit field in the instruction, with each bit corresponding to a register. A 1 in bit 0 of the register field will cause R0 to be transferred, a 0 will cause it not to be transferred; similarly bit 1 controls the transfer of R1, and so on.

Any subset of the registers, or all the registers, may be specified. The only restriction is that the register list should not be empty.

Whenever R15 is stored to memory the stored value is the address of the STM instruction plus 12.

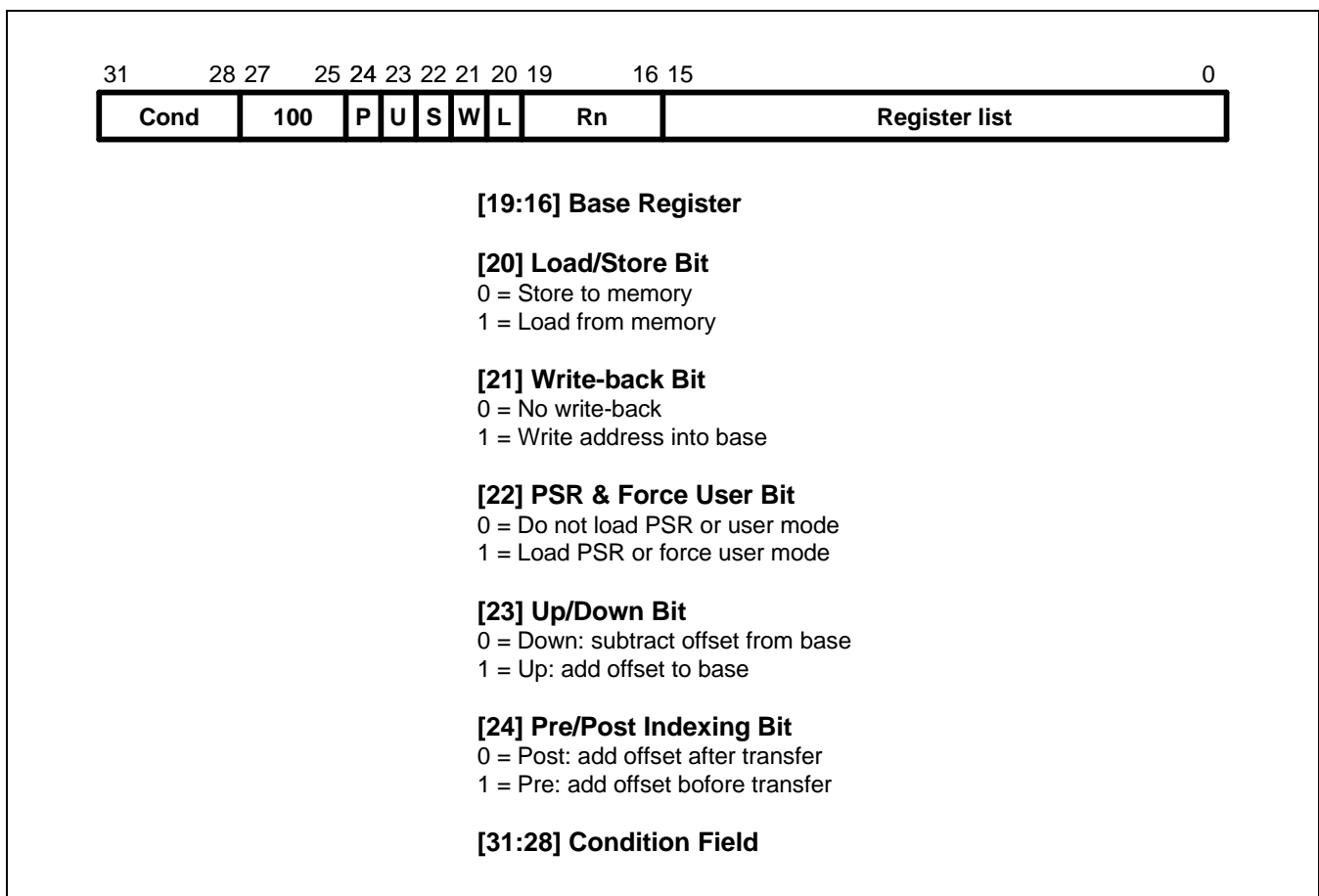

Figure 3-18. Block Data Transfer Instructions

3.11.2 ADDRESSING MODES

The transfer addresses are determined by the contents of the base register (Rn), the pre/post bit (P) and the up/down bit (U). The registers are transferred in the order lowest to highest, so R15 (if in the list) will always be transferred last. The lowest register also gets transferred to/from the lowest memory address. By way of illustration, consider the transfer of R1, R5 and R7 in the case where Rn = 0x1000 and write back of the modified base is required (W = 1). Figure 3.19-22 show the sequence of register transfers, the addresses used, and the value of Rn after the instruction has completed.

In all cases, had write back of the modified base not been required (W = 0), Rn would have retained its initial value of 0x1000 unless it was also in the transfer list of a load multiple register instruction, when it would have been overwritten with the loaded value.

3.11.3 ADDRESS ALIGNMENT

The address should normally be a word aligned quantity and non-word aligned addresses do not affect the instruction. However, the bottom 2 bits of the address will appear on A[1:0] and might be interpreted by the memory system.

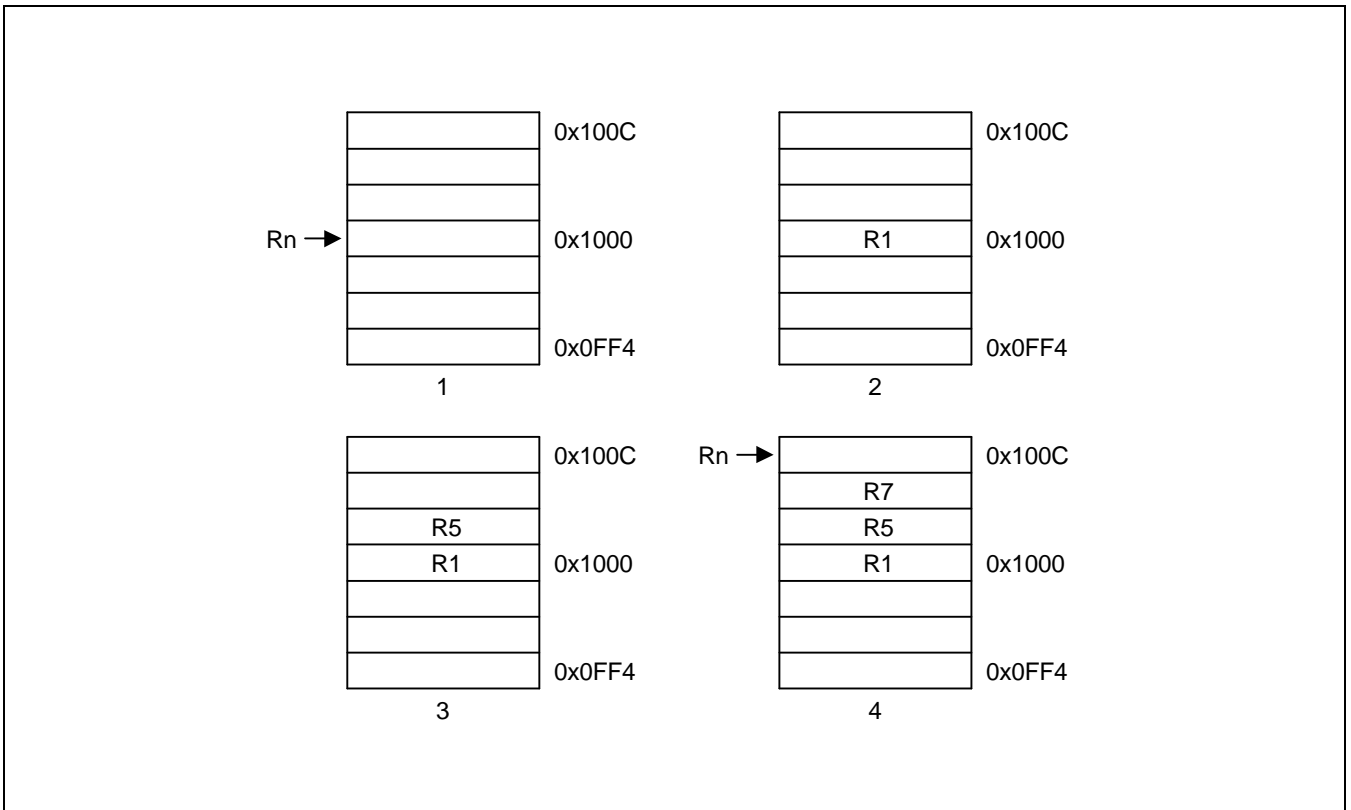

Figure 3-19. Post-Increment Addressing

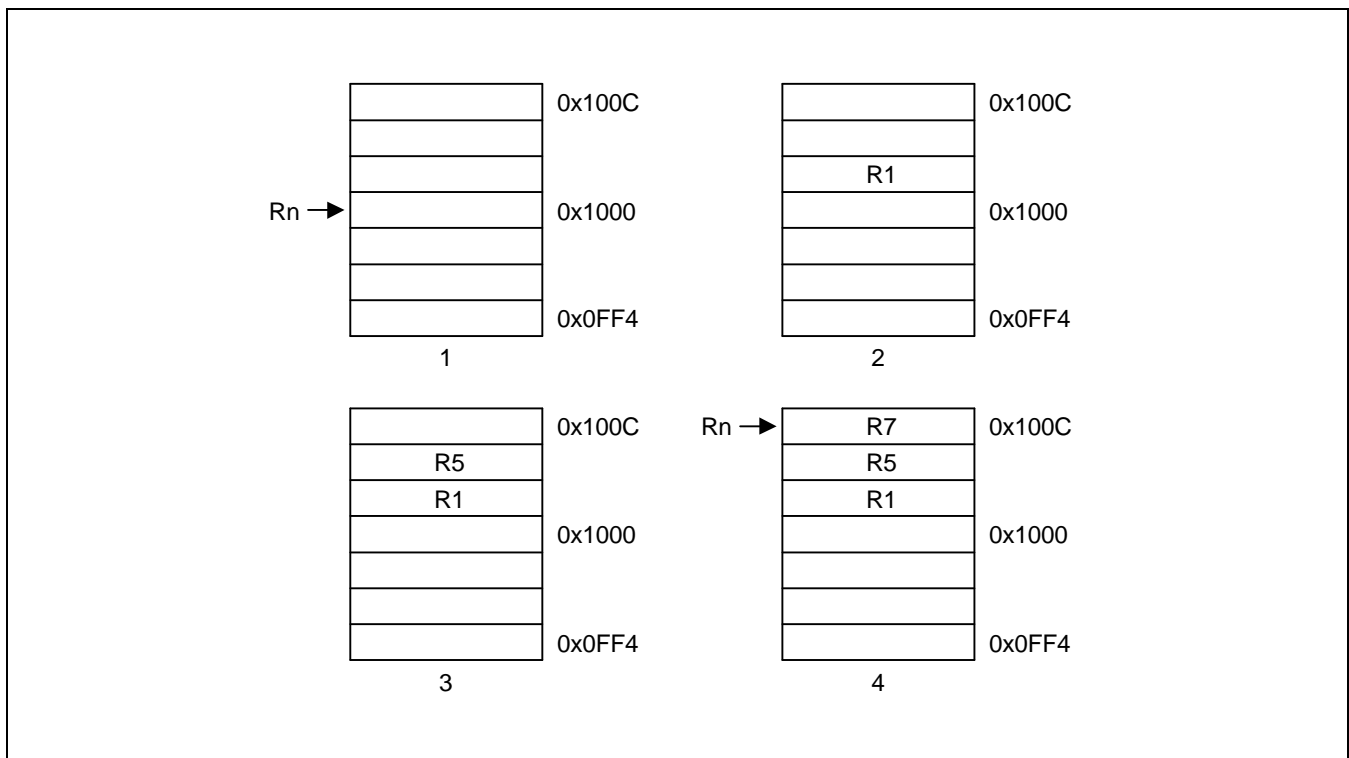

Figure 3-20. Pre-Increment Addressing

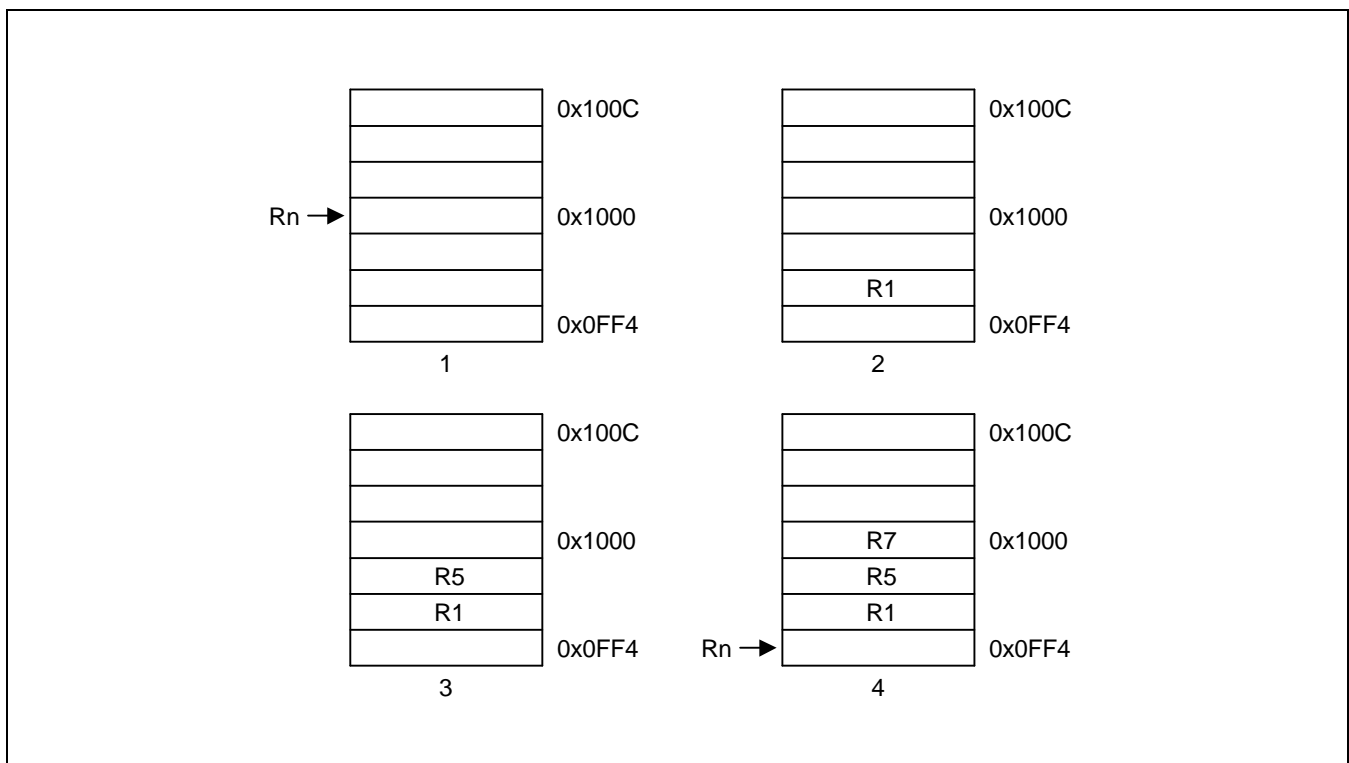

Figure 3-21. Post-Decrement Addressing

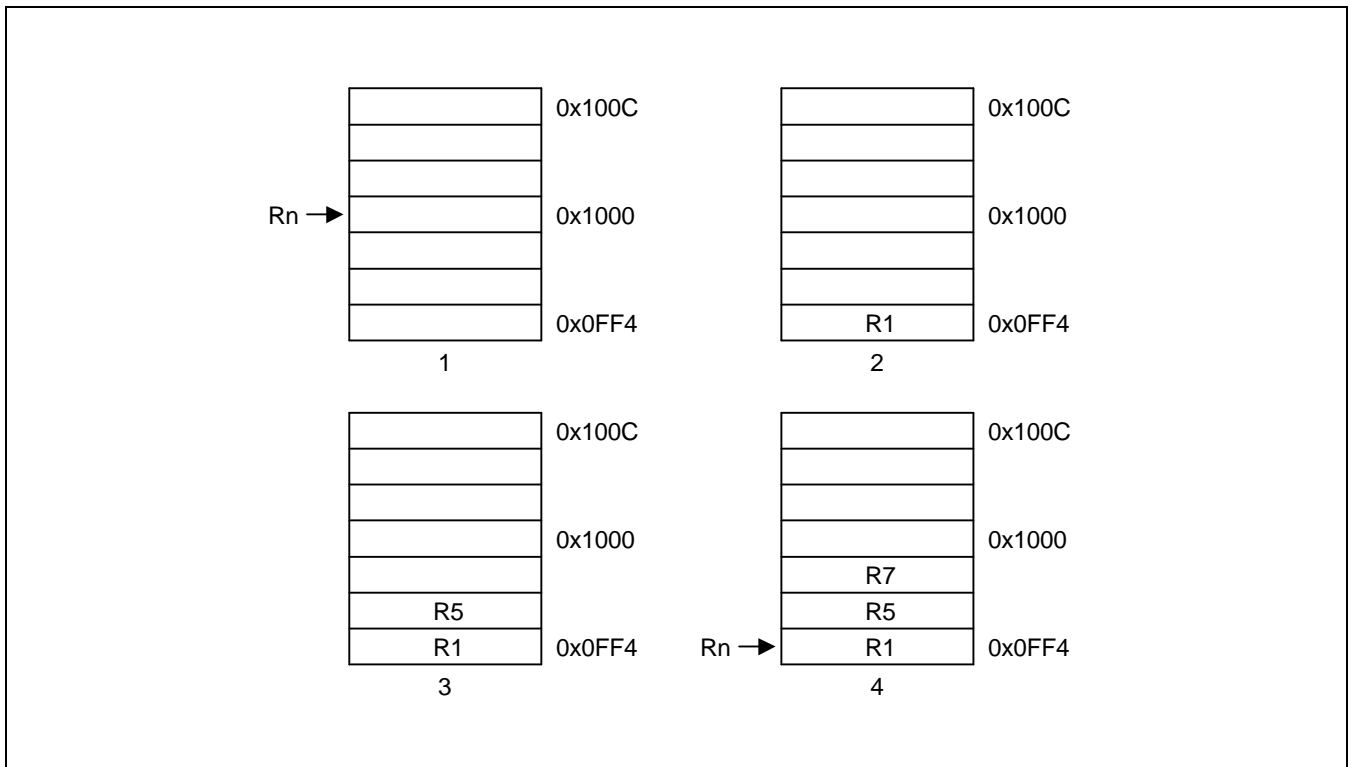

Figure 3-22. Pre-Decrement Addressing

3.11.4 USE OF THE S BIT

When the S bit is set in a LDM/STM instruction its meaning depends on whether or not R15 is in the transfer list and on the type of instruction. The S bit should only be set if the instruction is to execute in a privileged mode.

3.11.4.1 LDM with R15 in Transfer List and S Bit Set (Mode Changes)

If the instruction is a LDM then SPSR_<mode> is transferred to CPSR at the same time as R15 is loaded.

3.11.4.2 STM with R15 in Transfer List and S Bit Set (User Bank Transfer)

The registers transferred are taken from the user bank rather than the bank corresponding to the current mode. This is useful for saving the user state on process switches. Base write-back should not be used when this mechanism is employed.

3.11.4.3 R15 not in List and S Bit Set (User Bank Transfer)

For both LDM and STM instructions, the user bank registers are transferred rather than the register bank corresponding to the current mode. This is useful for saving the user state on process switches. Base write-back should not be used when this mechanism is employed.

When the instruction is LDM, care must be taken not to read from a banked register during the following cycle (inserting a dummy instruction such as MOV R0, R0 after the LDM will ensure safety).

3.11.5 USE OF R15 AS THE BASE

R15 should not be used as the base register in any LDM or STM instruction.

3.11.6 INCLUSION OF THE BASE IN THE REGISTER LIST

When write-back is specified, the base is written back at the end of the second cycle of the instruction. During a STM, the first register is written out at the start of the second cycle. A STM which includes storing the base, with the base as the first register to be stored, will therefore store the unchanged value, whereas with the base second or later in the transfer order, will store the modified value. A LDM will always overwrite the updated base if the base is in the list.

3.11.7 DATA ABORTS

Some legal addresses may be unacceptable to a memory management system, and the memory manager can indicate a problem with an address by taking the abort signal high. This can happen on any transfer during a multiple register load or store, and must be recoverable if ARM9TDMI is to be used in a virtual memory system.

3.11.7.1 Aborts During STM Instructions

If the abort occurs during a store multiple instruction, ARM9TDMI takes little action until the instruction completes, whereupon it enters the data abort trap. The memory manager is responsible for preventing erroneous writes to the memory. The only change to the internal state of the processor will be the modification of the base register if write-back was specified, and this must be reversed by software (and the cause of the abort resolved) before the instruction may be retried.

3.11.7.2 Aborts During LDM Instructions

When ARM9TDMI detects a data abort during a load multiple instruction, it modifies the operation of the instruction to ensure that recovery is possible.

- Overwriting of registers stops when the abort happens. The aborting load will not take place but earlier ones may have overwritten registers. The PC is always the last register to be written and so will always be preserved.
- The base register is restored, to its modified value if write-back was requested. This ensures recoverability in the case where the base register is also in the transfer list, and may have been overwritten before the abort occurred.

The data abort trap is taken when the load multiple has completed, and the system software must undo any base modification (and resolve the cause of the abort) before restarting the instruction.

3.11.8 INSTRUCTION CYCLE TIMES

Normal LDM instructions take $nS + 1N + 1I$ and LDM PC takes $(n+1)S + 2N + 1I$ incremental cycles, where S,N and I are defined as sequential (S-cycle), non-sequential (N-cycle), and internal (I-cycle), respectively. STM instructions take $(n-1)S + 2N$ incremental cycles to execute, where n is the number of words transferred.

3.11.9 ASSEMBLER SYNTAX

<LDM|STM>{cond}<FD|ED|FA|EA|IA|IB|DA|DB> Rn{!},<Rlist>{^}

where:

{cond}	Two character condition mnemonic. See Table 3-2.
Rn	An expression evaluating to a valid register number
<Rlist>	A list of registers and register ranges enclosed in {} (e.g. {R0, R2–R7, R10}).
{!}	If present requests write-back (W = 1), otherwise W = 0.
{^}	If present set S bit to load the CPSR along with the PC, or force transfer of user bank when in privileged mode.

3.11.9.1 Addressing Mode Names

There are different assembler mnemonics for each of the addressing modes, depending on whether the instruction is being used to support stacks or for other purposes. The equivalence between the names and the values of the bits in the instruction are shown in the following table 3-6.

Table 3-6. Addressing Mode Names

Name	Stack	Other	L Bit	P Bit	U Bit
Pre-Increment load	LDMED	LDMIB	1	1	1
Post-Increment load	LDMFD	LDMIA	1	0	1
Pre-Decrement load	LDMEA	LDMDB	1	1	0
Post-Decrement load	LDMFA	LDMDA	1	0	0
Pre-Increment store	STMFA	STMIB	0	1	1
Post-Increment store	STMEA	STMIA	0	0	1
Pre-Decrement store	STMFD	STMDB	0	1	0
Post-Decrement store	STMED	STMDA	0	0	0

FD, ED, FA, EA define pre/post indexing and the up/down bit by reference to the form of stack required. The F and E refer to a “full” or “empty” stack, i.e. whether a pre-index has to be done (full) before storing to the stack. The A and D refer to whether the stack is ascending or descending. If ascending, a STM will go up and LDM down, if descending, vice-versa.

IA, IB, DA, DB allow control when LDM/STM are not being used for stacks and simply mean increment after, increment before, decrement after, decrement before.

Examples

```
LDMFD    SP!,{R0,R1,R2}    ; Unstack 3 registers.
STMIA    R0,{R0-R15}      ; Save all registers.
LDMFD    SP!,{R15}        ; R15 <- (SP), CPSR unchanged.
LDMFD    SP!,{R15}^       ; R15 <- (SP), CPSR <- SPSR_mode
                                     ; (allowed only in privileged modes).
STMFD    R13,{R0-R14}^    ; Save user mode regs on stack
                                     ; (allowed only in privileged modes).
```

These instructions may be used to save state on subroutine entry, and restore it efficiently on return to the calling routine:

```
STMED    SP!,{R0-R3,R14}  ; Save R0 to R3 to use as workspace
                                     ; and R14 for returning.
BL        somewhere       ; This nested call will overwrite R14
LDMED    SP!,{R0-R3,R15}  ; Restore workspace and return.
```

3.12 SINGLE DATA SWAP (SWP)

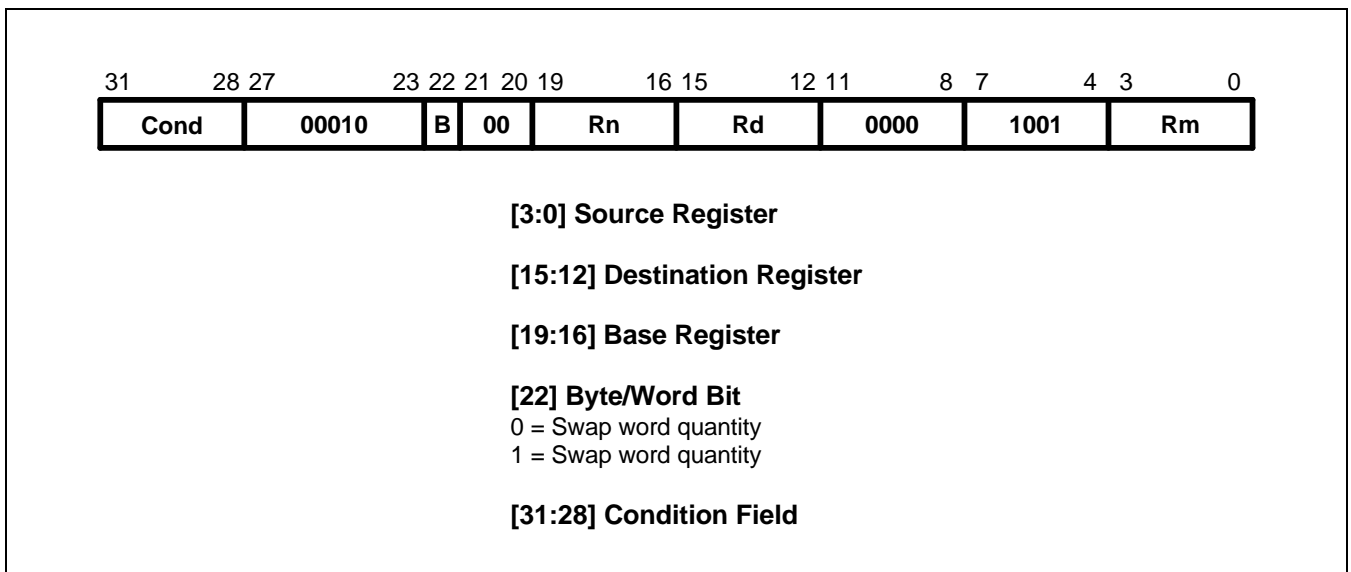

Figure 3-23. Swap Instruction

The instruction is only executed if the condition is true. The various conditions are defined in Table 3-2. The instruction encoding is shown in Figure 3-23.

The data swap instruction is used to swap a byte or word quantity between a register and external memory. This instruction is implemented as a memory read followed by a memory write which are “locked” together (the processor cannot be interrupted until both operations have completed, and the memory manager is warned to treat them as inseparable). This class of instruction is particularly useful for implementing software semaphores.

The swap address is determined by the contents of the base register (Rn). The processor first reads the contents of the swap address. Then it writes the contents of the source register (Rm) to the swap address, and stores the old memory contents in the destination register (Rd). The same register may be specified as both the source and destination.

The lock output goes HIGH for the duration of the read and write operations to signal to the external memory manager that they are locked together, and should be allowed to complete without interruption. This is important in multi-processor systems where the swap instruction is the only indivisible instruction which may be used to implement semaphores; control of the memory must not be removed from a processor while it is performing a locked operation.

3.12.1 BYTES AND WORDS

This instruction class may be used to swap a byte (B = 1) or a word (B = 0) between an ARM9TDMI register and memory. The SWP instruction is implemented as a LDR followed by a STR and the action of these is as described in the section on single data transfers. In particular, the description of Big and Little Endian configuration applies to the SWP instruction.

3.12.2 USE OF R15

Do not use R15 as an operand (Rd, Rn or Rs) in a SWP instruction.

3.12.3 DATA ABORTS

If the address used for the swap is unacceptable to a memory management system, the memory manager can flag the problem by driving ABORT HIGH. This can happen on either the read or the write cycle (or both), and in either case, the data abort trap will be taken. It is up to the system software to resolve the cause of the problem, then the instruction can be restarted and the original program continued.

3.12.4 INSTRUCTION CYCLE TIMES

Swap instructions take $1S + 2N + 1I$ incremental cycles to execute, where S, N and I are defined as sequential (S-cycle), non-sequential, and internal (I-cycle), respectively.

3.12.5 ASSEMBLER SYNTAX

<SWP>{cond}{B} Rd,Rm,[Rn]

{cond}	Two-character condition mnemonic. See Table 3-2.
{B}	If B is present then byte transfer, otherwise word transfer
Rd,Rm,Rn	Expressions evaluating to valid register numbers

Examples

SWP	R0,R1,[R2]	; Load R0 with the word addressed by R2, and ; store R1 at R2.
SWPB	R2,R3,[R4]	; Load R2 with the byte addressed by R4, and ; store bits 0 to 7 of R3 at R4.
SWPEQ	R0,R0,[R1]	; Conditionally swap the contents of the ; word addressed by R1 with R0.

3.13 SOFTWARE INTERRUPT (SWI)

The instruction is only executed if the condition is true. The various conditions are defined in Table 3-2. The instruction encoding is shown in Figure 3-24, below

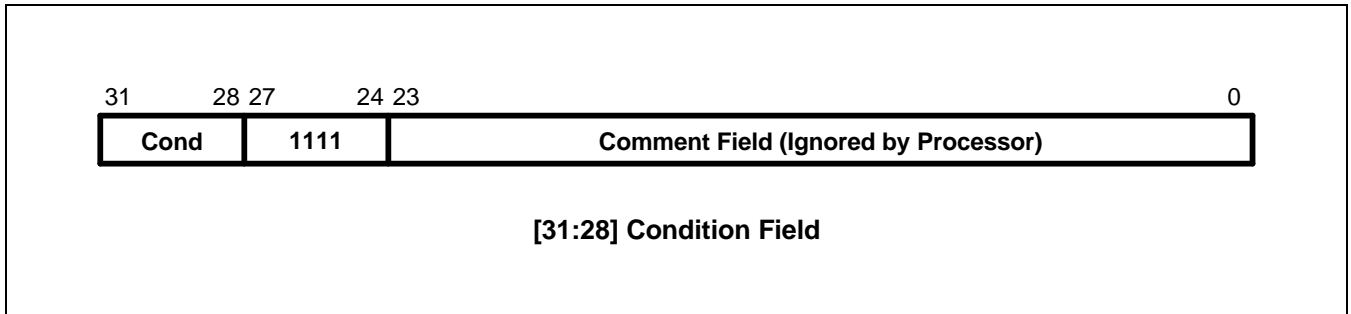

Figure 3-24. Software Interrupt Instruction

The software interrupt instruction is used to enter supervisor mode in a controlled manner. The instruction causes the software interrupt trap to be taken, which effects the mode change. The PC is then forced to a fixed value (0x08) and the CPSR is saved in SPSR_svc. If the SWI vector address is suitably protected (by external memory management hardware) from modification by the user, a fully protected operating system may be constructed.

3.13.1 RETURN FROM THE SUPERVISOR

The PC is saved in R14_svc upon entering the software interrupt trap, with the PC adjusted to point to the word after the SWI instruction. MOVs PC,R14_svc will return to the calling program and restore the CPSR.

Note that the link mechanism is not re-entrant, so if the supervisor code wishes to use software interrupts within itself it must first save a copy of the return address and SPSR.

3.13.2 COMMENT FIELD

The bottom 24 bits of the instruction are ignored by the processor, and may be used to communicate information to the supervisor code. For instance, the supervisor may look at this field and use it to index into an array of entry points for routines which perform the various supervisor functions.

3.13.3 INSTRUCTION CYCLE TIMES

Software interrupt instructions take $2S + 1N$ incremental cycles to execute, where S and N are defined as sequential (S-cycle) and non-sequential (N-cycle).

3.13.4 ASSEMBLER SYNTAX

SWI{cond} <expression>

{cond} Two character condition mnemonic, Table 3-2.

<expression> Evaluated and placed in the comment field (which is ignored by ARM9TDMI).

Examples

```

SWI      ReadC           ; Get next character from read stream.
SWI      Writel+ "k"     ; Output a "k" to the write stream.
SWINE    0               ; Conditionally call supervisor with 0 in comment field.

```

Supervisor code

The previous examples assume that suitable supervisor code exists, for instance:

```

0x08 B Supervisor      ; SWI entry point
EntryTable             ; Addresses of supervisor routines
DCD ZeroRtn
DCD ReadCRtn
DCD WritelRtn
...
Zero EQU 0
ReadC EQU 256
Writel EQU 512
Supervisor             ; SWI has routine required in bits 8-23 and data (if any) in
                       ; bits 0-7. Assumes R13_svc points to a suitable stack
STMFD R13,{R0-R2,R14} ; Save work registers and return address.
LDR R0,[R14,#-4]       ; Get SWI instruction.
BIC R0,R0,#0xFF000000 ; Clear top 8 bits.
MOV R1,R0,LSR#8        ; Get routine offset.
ADR R2,EntryTable     ; Get start address of entry table.
LDR R15,[R2,R1,LSL#2] ; Branch to appropriate routine.
WritelRtn             ; Enter with character in R0 bits 0-7.
...
LDMFD R13,{R0-R2,R15}^ ; Restore workspace and return,
                       ; restoring processor mode and flags.

```

3.14 COPROCESSOR DATA OPERATIONS (CDP)

The instruction is only executed if the condition is true. The various conditions are defined in Table 3-2. The instruction encoding is shown in Figure 3-25.

This class of instruction is used to tell a coprocessor to perform some internal operation. No result is communicated back to ARM9TDMI, and it will not wait for the operation to complete. The coprocessor could contain a queue of such instructions awaiting execution, and their execution can overlap other activity, allowing the coprocessor and ARM9TDMI to perform independent tasks in parallel.

3.14.1 COPROCESSOR INSTRUCTIONS

The S3C2501X, unlike some other ARM-based processors, does not have an external coprocessor interface. It does not have a on-chip coprocessor also.

So then all coprocessor instructions will cause the undefined instruction trap to be taken on the S3C2501X. These coprocessor instructions can be emulated by the undefined trap handler. Even though external coprocessor can not be connected to the S3C2501X, the coprocessor instructions are still described here in full for completeness. (Remember that any external coprocessor described in this section is a software emulation.)

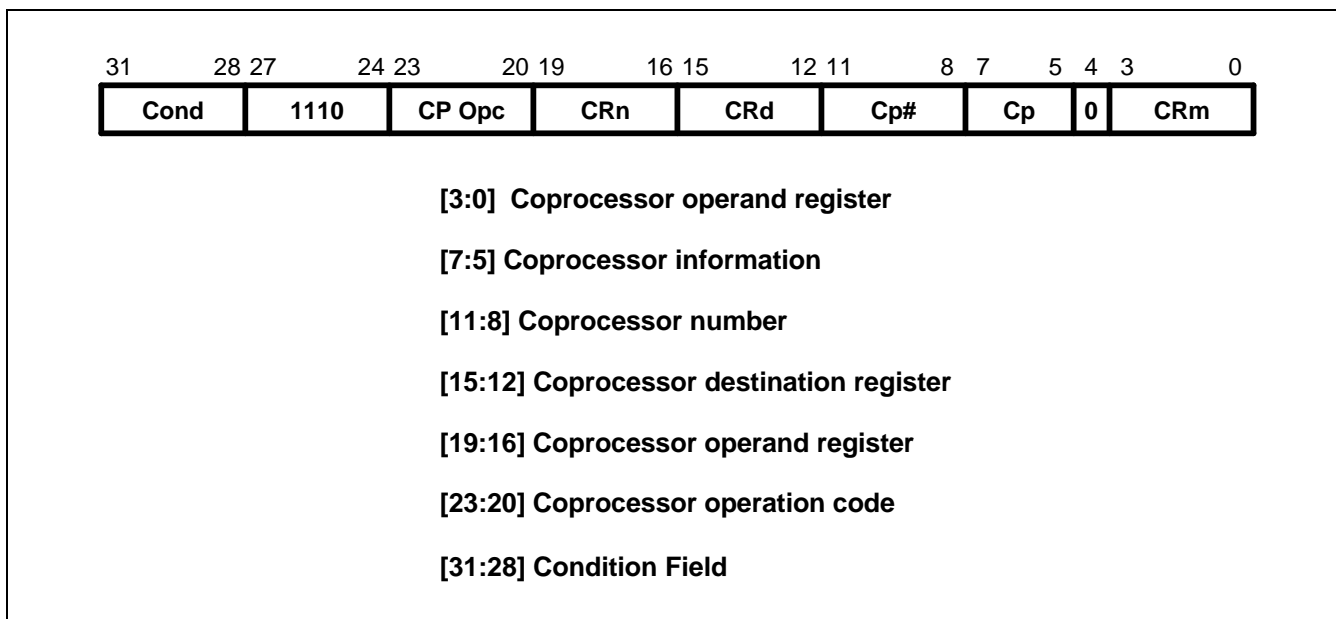

Figure 3-25. Coprocessor Data Operation Instruction

3.14.2 THE COPROCESSOR FIELDS

Only bit 4 and bits 24 to 31 are significant to ARM9TDMI. The remaining bits are used by coprocessors. The above field names are used by convention, and particular coprocessors may redefine the use of all fields except CP# as appropriate. The CP# field is used to contain an identifying number (in the range 0 to 15) for each coprocessor, and a coprocessor will ignore any instruction which does not contain its number in the CP# field.

The conventional interpretation of the instruction is that the coprocessor should perform an operation specified in the CP Opc field (and possibly in the CP field) on the contents of CRn and CRm, and place the result in CRd.

3.14.3 INSTRUCTION CYCLE TIMES

Coprocessor data operations take $1S + bI$ incremental cycles to execute, where b is the number of cycles spent in the coprocessor busy-wait loop.

S and I are defined as sequential (S-cycle) and internal (I-cycle).

3.14.4 ASSEMBLER SYNTAX

CDP{cond} p#,<expression1>,cd,cn,cm{,<expression2>}

{cond}	Two character condition mnemonic. See Table 3-2.
p#	The unique number of the required coprocessor
<expression1>	Evaluated to a constant and placed in the CP Opc field
cd, cn and cm	Evaluate to the valid coprocessor register numbers CRd, CRn and CRm respectively
<expression2>	Where present is evaluated to a constant and placed in the CP field

Examples

CDP	p1,10,c1,c2,c3	; Request coproc 1 to do operation 10 ; on CR2 and CR3, and put the result in CR1.
CDPEQ	p2,5,c1,c2,c3,2	; If Z flag is set request coproc 2 to do operation 5 (type 2) ; on CR2 and CR3, and put the result in CR1.

3.15 COPROCESSOR DATA TRANSFERS (LDC, STC)

The instruction is only executed if the condition is true. The various conditions are defined in Table 3-2. The instruction encoding is shown in Figure 3-26.

This class of instruction is used to load (LDC) or store (STC) a subset of a coprocessor's registers directly to memory. ARM9TDMI is responsible for supplying the memory address, and the coprocessor supplies or accepts the data and controls the number of words transferred.

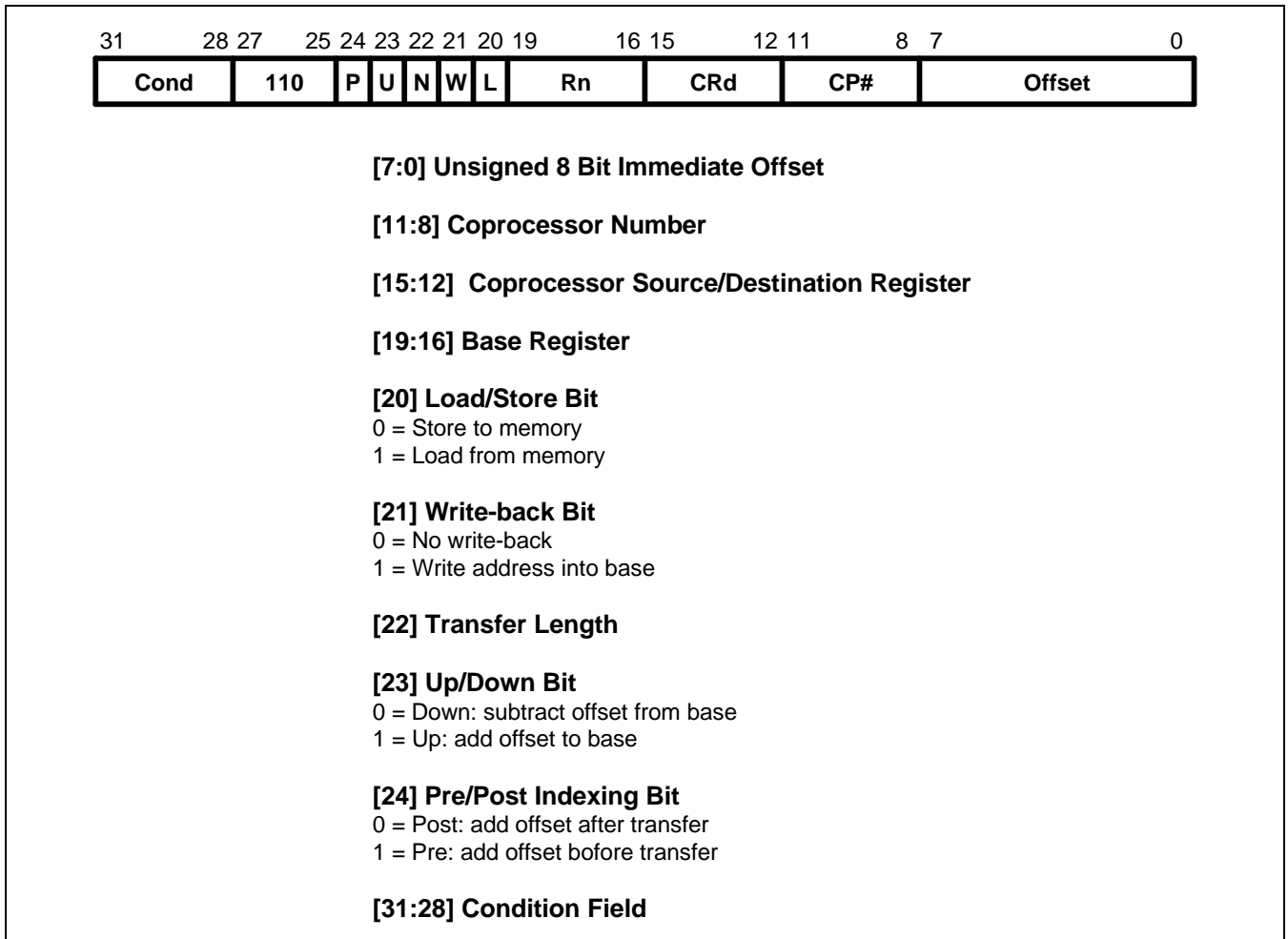

Figure 3-26. Coprocessor Data Transfer Instructions

3.15.1 THE COPROCESSOR FIELDS

The CP# field is used to identify the coprocessor which is required to supply or accept the data, and a coprocessor will only respond if its number matches the contents of this field.

The CRd field and the N bit contain information for the coprocessor which may be interpreted in different ways by different coprocessors, but by convention CRd is the register to be transferred (or the first register where more than one is to be transferred), and the N bit is used to choose one of two transfer length options. For instance N = 0 could select the transfer of a single register, and N = 1 could select the transfer of all the registers for context switching.

3.15.2 ADDRESSING MODES

ARM9TDMI is responsible for providing the address used by the memory system for the transfer, and the addressing modes available are a subset of those used in single data transfer instructions. Note, however, that the immediate offsets are 8 bits wide and specify word offsets for coprocessor data transfers, whereas they are 12 bits wide and specify byte offsets for single data transfers.

The 8 bit unsigned immediate offset is shifted left 2 bits and either added to ($U = 1$) or subtracted from ($U = 0$) the base register (R_n); this calculation may be performed either before ($P = 1$) or after ($P = 0$) the base is used as the transfer address. The modified base value may be overwritten back into the base register (if $W = 1$), or the old value of the base may be preserved ($W = 0$). Note that post-indexed addressing modes require explicit setting of the W bit, unlike LDR and STR which always write-back when post-indexed.

The value of the base register, modified by the offset in a pre-indexed instruction, is used as the address for the transfer of the first word. The second word (if more than one is transferred) will go to or come from an address one word (4 bytes) higher than the first transfer, and the address will be incremented by one word for each subsequent transfer.

3.15.3 ADDRESS ALIGNMENT

The base address should normally be a word aligned quantity. The bottom 2 bits of the address will appear on $A[1:0]$ and might be interpreted by the memory system.

3.15.4 USE OF R15

If R_n is R15, the value used will be the address of the instruction plus 8 bytes. Base write-back to R15 must not be specified.

3.15.5 DATA ABORTS

If the address is legal but the memory manager generates an abort, the data trap will be taken. The write-back of the modified base will take place, but all other processor state will be preserved. The coprocessor is partly responsible for ensuring that the data transfer can be restarted after the cause of the abort has been resolved, and must ensure that any subsequent actions it undertakes can be repeated when the instruction is retried.

3.15.6 INSTRUCTION CYCLE TIMES

Coprocessor data transfer instructions take $(n-1)S + 2N + B$ incremental cycles to execute, where:

- N The number of words transferred.
- B The number of cycles spent in the coprocessor busy-wait loop.

S, N and I are defined as sequential (S-cycle), non-sequential (N-cycle), and internal (I-cycle), respectively.

3.15.7 ASSEMBLER SYNTAX

<LDC|STC>{cond}{L} p#,cd,<Address>

LDC	Load from memory to coprocessor
STC	Store from coprocessor to memory
{L}	When present perform long transfer (N = 1), otherwise perform short transfer (N = 0)
{cond}	Two character condition mnemonic. See Table 3-2.
p#	The unique number of the required coprocessor
Cd	An expression evaluating to a valid coprocessor register number that is placed in the CRd field

<Address> can be:

- 1 An expression which generates an address:
The assembler will attempt to generate an instruction using the PC as a base and a corrected immediate offset to address the location given by evaluating the expression. This will be a PC relative, pre-indexed address. If the address is out of range, an error will be generated
- 2 A pre-indexed addressing specification:
[Rn] offset of zero
[Rn,<#expression>]{!} offset of <expression> bytes
A post-indexed addressing specification:
Rn,<#expression> offset of <expression> bytes
{!} write back the base register (set the W bit) if ! is present
Rn is an expression evaluating to a valid ARM9TDMI register number.

NOTE

If Rn is R15, the assembler will subtract 8 from the offset value to allow for ARM9TDMI pipelining.

Examples

LDC	p1,c2,table	; Load c2 of coproc 1 from address ; table, using a PC relative address.
STCEQL	p2,c3,[R5,#24]!	; Conditionally store c3 of coproc 2 ; into an address 24 bytes up from R5, ; write this address back to R5, and use ; long transfer option (probably to store multiple words).

NOTE

Although the address offset is expressed in bytes, the instruction offset field is in words. The assembler will adjust the offset appropriately.

3.16 COPROCESSOR REGISTER TRANSFERS (MRC, MCR)

The instruction is only executed if the condition is true. The various conditions are defined in Table 3-2.. The instruction encoding is shown in Figure 3-27.

This class of instruction is used to communicate information directly between ARM9TDMI and a coprocessor. An example of a coprocessor to ARM9TDMI register transfer (MRC) instruction would be a FIX of a floating point value held in a coprocessor, where the floating point number is converted into a 32 bit integer within the coprocessor, and the result is then transferred to ARM9TDMI register. A FLOAT of a 32 bit value in ARM9TDMI register into a floating point value within the coprocessor illustrates the use of ARM9TDMI register to coprocessor transfer (MCR).

An important use of this instruction is to communicate control information directly from the coprocessor into the ARM9TDMI CPSR flags. As an example, the result of a comparison of two floating point values within a coprocessor can be moved to the CPSR to control the subsequent flow of execution.

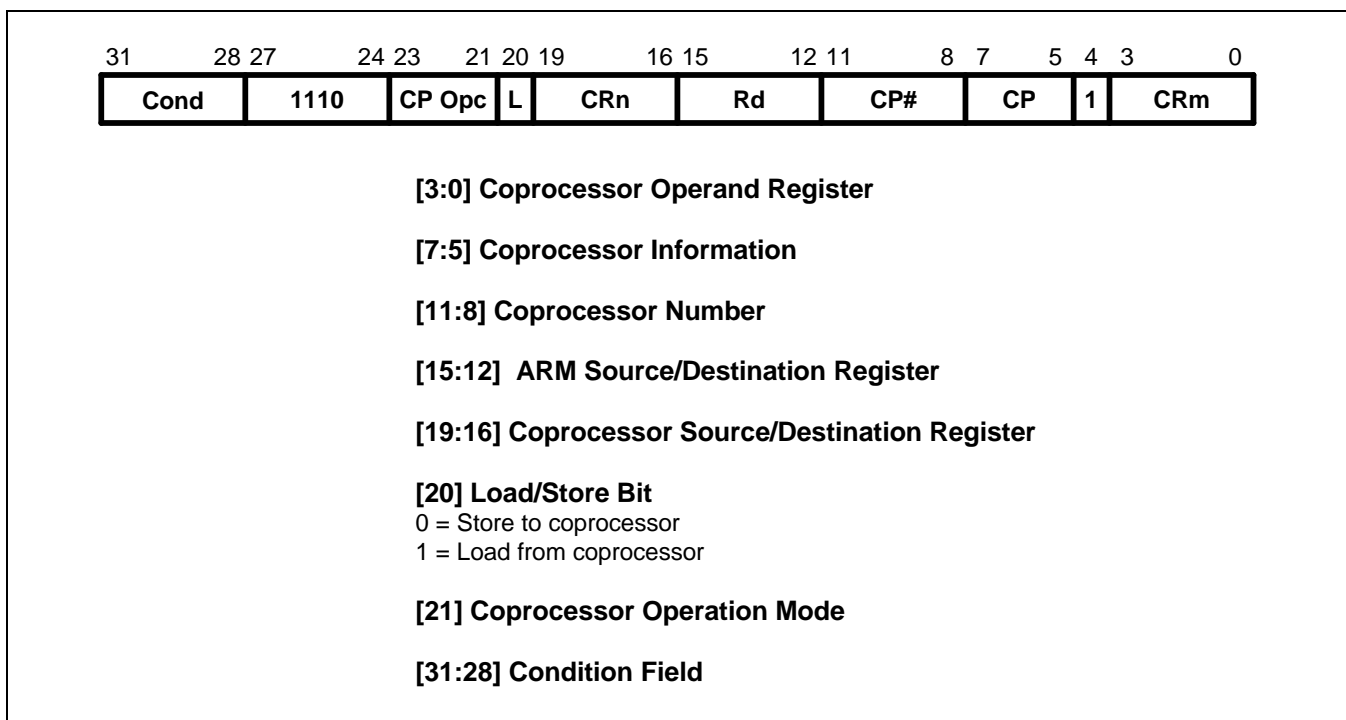

Figure 3-27. Coprocessor Register Transfer Instructions

3.16.1 THE COPROCESSOR FIELDS

The CP# field is used, as for all coprocessor instructions, to specify which coprocessor is being called upon.

The CP Opc, CRn, CP and CRm fields are used only by the coprocessor, and the interpretation presented here is derived from convention only. Other interpretations are allowed where the coprocessor functionality is incompatible with this one. The conventional interpretation is that the CP Opc and CP fields specify the operation the coprocessor is required to perform, CRn is the coprocessor register which is the source or destination of the transferred information, and CRm is a second coprocessor register which may be involved in some way which depends on the particular operation specified.

3.16.2 TRANSFERS TO R15

When a coprocessor register transfer to ARM9TDMI has R15 as the destination, bits 31, 30, 29 and 28 of the transferred word are copied into the N, Z, C and V flags respectively. The other bits of the transferred word are ignored, and the PC and other CPSR bits are unaffected by the transfer.

3.16.3 TRANSFERS FROM R15

A coprocessor register transfer from ARM9TDMI with R15 as the source register will store the PC+ 12.

3.16.4 INSTRUCTION CYCLE TIMES

MRC instructions take $1S + (b+1)I + 1C$ incremental cycles to execute, where S, I and C are defined as sequential (S-cycle), internal (I-cycle), and coprocessor register transfer (C-cycle), respectively. MCR instructions take $1S + bI + 1C$ incremental cycles to execute, where *b* is the number of cycles spent in the coprocessor busy-wait loop.

3.16.5 ASSEMBLER SYNTAX

<MCR|MRC>{<cond>} p#,<expression1>,Rd,cn,cm{,<expression2>}

MRC	Move from coprocessor to ARM9TDMI register (L = 1)
MCR	Move from ARM9TDMI register to coprocessor (L = 0)
{<cond>}	Two character condition mnemonic. See Table 3-2.
p#	The unique number of the required coprocessor
<expression1>	Evaluated to a constant and placed in the CP Opc field
Rd	An expression evaluating to a valid ARM9TDMI register number
cn and cm	Expressions evaluating to the valid coprocessor register numbers CRn and CRm respectively
<expression2>	Where present is evaluated to a constant and placed in the CP field

Examples

MRC	p2,5,R3,c5,c6	; Request coproc 2 to perform operation 5 ; on c5 and c6, and transfer the (single ; 32-bit word) result back to R3.
MCR	p6,0,R4,c5,c6	; Request coproc 6 to perform operation 0 ; on R4 and place the result in c6.
MRCEQ	p3,9,R3,c5,c6,2	; Conditionally request coproc 3 to ; perform operation 9 (type 2) on c5 and ; c6, and transfer the result back to R3.

3.17 UNDEFINED INSTRUCTION

The instruction is only executed if the condition is true. The various conditions are defined in Table 3-2. The instruction format is shown in Figure 3-28.

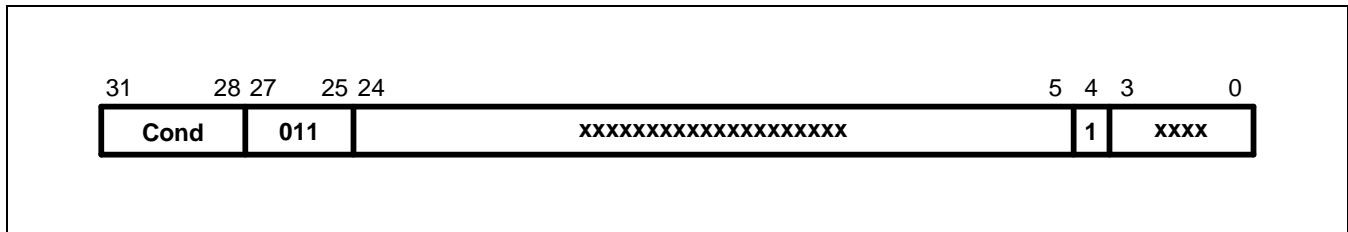

Figure 3-28. Undefined Instruction

If the condition is true, the undefined instruction trap will be taken.

Note that the undefined instruction mechanism involves offering this instruction to any coprocessors which may be present, and all coprocessors must refuse to accept it by driving CPA and CPB HIGH.

3.17.1 INSTRUCTION CYCLE TIMES

This instruction takes $2S + 1I + 1N$ cycles, where S, N and I are defined as sequential (S-cycle), non-sequential (N-cycle), and internal (I-cycle).

3.17.2 ASSEMBLER SYNTAX

The assembler has no mnemonics for generating this instruction. If it is adopted in the future for some specified use, suitable mnemonics will be added to the assembler. Until such time, this instruction must not be used.

3.18 INSTRUCTION SET EXAMPLES

The following examples show ways in which the basic ARM9TDMI instructions can combine to give efficient code. None of these methods saves a great deal of execution time (although they may save some), mostly they just save code.

3.18.1 USING THE CONDITIONAL INSTRUCTIONS

Using Conditionals for Logical OR

```

CMP      Rn,#p          ; If Rn=p OR Rm=q THEN GOTO Label.
BEQ      Label
CMP      Rm,#q
BEQ      Label

```

This can be replaced by

```

CMP      Rn,#p
CMPNE   Rm,#q          ; If condition not satisfied try other test.
BEQ      Label

```

Absolute Value

```

TEQ      Rn,#0          ; Test sign
RSBMI   Rn,Rn,#0       ; and 2's complement if necessary.

```

Multiplication by 4, 5 or 6 (Run Time)

```

MOV      Rc,Ra,LSL#2    ; Multiply by 4,
CMP      Rb,#5          ; Test value,
ADDCS   Rc,Rc,Ra        ; Complete multiply by 5,
ADDHI   Rc,Rc,Ra        ; Complete multiply by 6.

```

Combining Discrete and Range Tests

```

TEQ      Rc,#127        ; Discrete test,
CMPNE   Rc,#" " - 1    ; Range test
MOVLS   Rc,#" "        ; IF Rc<= " " OR Rc=ASCII(127)
                          ; THEN Rc:= " "

```

Division and Remainder

A number of divide routines for specific applications are provided in source form as part of the ANSI C library provided with the ARM Cross development toolkit, available from your supplier. A short general purpose divide routine follows.

```

; Enter with numbers in Ra and Rb.
; Bit to control the division.
; Move Rb until greater than Ra.
Div1      MOV      Rcnt,#1
          CMP      Rb,#0x80000000
          CMPCC   Rb,Ra
          MOVCC   Rb,Rb,ASL#1
          MOVCC   Rcnt,Rcnt,ASL#1
          BCC     Div1
          MOV      Rc,#0
Div2      CMP      Ra,Rb      ; Test for possible subtraction.
          SUBCS   Ra,Ra,Rb    ; Subtract if ok,
          ADDCS   Rc,Rc,Rcnt  ; Put relevant bit into result
          MOVS   Rcnt,Rcnt,LSR#1 ; Shift control bit
          MOVNE  Rb,Rb,LSR#1 ; Halve unless finished.
          BNE     Div2      ; Divide result in Rc, remainder in Ra.

```

Overflow Detection in the ARM9TDMI

1. Overflow in unsigned multiply with a 32-bit result

```

UMULL     Rd,Rt,Rm,Rn      ; 3 to 6 cycles
TEQ       Rt,#0           ; +1 cycle and a register
BNE       overflow

```

2. Overflow in signed multiply with a 32-bit result

```

SMULL     Rd,Rt,Rm,Rn      ; 3 to 6 cycles
TEQ       Rt,Rd,ASR#31    ; +1 cycle and a register
BNE       overflow

```

3. Overflow in unsigned multiply accumulate with a 32 bit result

```

UMLAL     Rd,Rt,Rm,Rn      ; 4 to 7 cycles
TEQ       Rt,#0           ; +1 cycle and a register
BNE       overflow

```

4. Overflow in signed multiply accumulate with a 32 bit result

```

SMLAL     Rd,Rt,Rm,Rn      ; 4 to 7 cycles
TEQ       Rt,Rd,ASR#31    ; +1 cycle and a register
BNE       overflow

```

5. Overflow in unsigned multiply accumulate with a 64 bit result

UMULL	RI,Rh,Rm,Rn	; 3 to 6 cycles
ADDS	RI,RI,Ra1	; Lower accumulate
ADC	Rh,Rh,Ra2	; Upper accumulate
BCS	overflow	; 1 cycle and 2 registers

6. Overflow in signed multiply accumulate with a 64 bit result

SMULL	RI,Rh,Rm,Rn	; 3 to 6 cycles
ADDS	RI,RI,Ra1	; Lower accumulate
ADC	Rh,Rh,Ra2	; Upper accumulate
BVS	overflow	; 1 cycle and 2 registers

NOTE

Overflow checking is not applicable to unsigned and signed multiplies with a 64-bit result, since overflow does not occur in such calculations.

3.18.2 PSEUDO-RANDOM BINARY SEQUENCE GENERATOR

It is often necessary to generate (pseudo-) random numbers and the most efficient algorithms are based on shift generators with exclusive-OR feedback rather like a cyclic redundancy check generator. Unfortunately the sequence of a 32 bit generator needs more than one feedback tap to be maximal length (i.e. $2^{32}-1$ cycles before repetition), so this example uses a 33 bit register with taps at bits 33 and 20. The basic algorithm is newbit: = bit 33 eor bit 20, shift left the 33 bit number and put in newbit at the bottom; this operation is performed for all the newbits needed (i.e. 32 bits). The entire operation can be done in 5 S cycles:

		; Enter with seed in Ra (32 bits),
		; Rb (1 bit in Rb lsb), uses Rc.
TST	Rb,Rb,LSR#1	; Top bit into carry
MOVS	Rc,Ra,RRX	; 33 bit rotate right
ADC	Rb,Rb,Rb	; Carry into lsb of Rb
EOR	Rc,Rc,Ra,LSL#12	; (involved!)
EOR	Ra,Rc,Rc,LSR#20	; (similarly involved!) new seed in Ra, Rb as before

3.18.3 MULTIPLICATION BY CONSTANT USING THE BARREL SHIFTER**Multiplication by 2^n (1,2,4,8,16,32..)**

MOV Ra, Rb, LSL #n

Multiplication by 2^{n+1} (3,5,9,17..)

ADD Ra,Ra,Ra,LSL #n

Multiplication by 2^{n-1} (3,7,15..)

RSB Ra,Ra,Ra,LSL #n

Multiplication by 6

```

ADD    Ra,Ra,Ra,LSL #1    ; Multiply by 3
MOV    Ra,Ra,LSL#1       ; and then by 2

```

Multiply by 10 and add in extra number

```

ADD    Ra,Ra,Ra,LSL#2     ; Multiply by 5
ADD    Ra,Rc,Ra,LSL#1     ; Multiply by 2 and add in next digit

```

General recursive method for $R_b := R_a * C$, C a constant:

1. If C even, say $C = 2^n * D$, D odd:

```

D=1:    MOV    Rb,Ra,LSL #n
D<>1:   {Rb := Ra*D}
MOV     Rb,Rb,LSL #n

```

2. If $C \text{ MOD } 4 = 1$, say $C = 2^n * D + 1$, D odd, $n > 1$:

```

D=1:    ADD    Rb,Ra,Ra,LSL #n
D<>1:   {Rb := Ra*D}
ADD     Rb,Ra,Rb,LSL #n

```

3. If $C \text{ MOD } 4 = 3$, say $C = 2^n * D - 1$, D odd, $n > 1$:

```

D=1:    RSB   Rb,Ra,Ra,LSL #n
D<>1:   {Rb := Ra*D}
RSB     Rb,Ra,Rb,LSL #n

```

This is not quite optimal, but close. An example of its non-optimality is multiply by 45 which is done by:

```

RSB     Rb,Ra,Ra,LSL#2    ; Multiply by 3
RSB     Rb,Ra,Rb,LSL#2    ; Multiply by  $4*3-1 = 11$ 
ADD     Rb,Ra,Rb,LSL# 2   ; Multiply by  $4*11+1 = 45$ 

```

rather than by:

```

ADD     Rb,Ra,Ra,LSL#3    ; Multiply by 9
ADD     Rb,Rb,Rb,LSL#2    ; Multiply by  $5*9 = 45$ 

```

3.18.4 LOADING A WORD FROM AN UNKNOWN ALIGNMENT

BIC	Rb,Ra,#3	; Enter with address in Ra (32 bits) uses
LDMIA	Rb,{Rd,Rc}	; Rb, Rc result in Rd. Note d must be less than c e.g. 0,1
AND	Rb,Ra,#3	; Get word aligned address
MOVS	Rb,Rb,LSL#3	; Get 64 bits containing answer
MOVNE	Rd,Rd,LSR Rb	; Correction factor in bytes
RSBNE	Rb,Rb,#32	; ...now in bits and test if aligned
ORRNE	Rd,Rd,Rc,LSL Rb	; Produce bottom of result word (if not aligned)
		; Get other shift amount
		; Combine two halves to get result

3.19 THUMB INSTRUCTION SET FORMAT

The thumb instruction sets are 16-bit versions of ARM instruction sets (32-bit format). The ARM instructions are reduced to 16-bit versions, Thumb instructions, at the cost of versatile functions of the ARM instruction sets. The thumb instructions are decompressed to the ARM instructions by the Thumb decompressor inside the ARM9TDMI core.

As the Thumb instructions are compressed ARM instructions, the Thumb instructions have the 16-bit format instructions and have some restrictions. The restrictions by 16-bit format is fully notified for using the Thumb instructions.

3.19.1 FORMAT SUMMARY

The THUMB instruction set formats are shown in the following figure.

	15	14	13	12	11	10	9	8	7	6	5	4	3	2	1	0	
1	0	0	0	Op		Offset5					Rs	Rd				Move Shifted register	
2	0	0	0	1	1	I	Op	Rn/offset3			Rs	Rd				Add/subtract	
3	0	0	1	Op		Rd				Offset8						Move/compare/add/ subtract immediate	
4	0	1	0	0	0	0	Op				Rs	Rd				ALU operations	
5	0	1	0	0	0	1	Op	H1	H2	Rs/Hs		Rd/Hd				Hi register operations /branch exchange	
6	0	1	0	0	1	Rd				Word8						PC-relative load	
7	0	1	0	1	L	B	0	Ro			Rb	Rd				Load/store with register offset	
8	0	1	0	1	H	S	1	Ro			Rb	Rd				Load/store sign-extended byte/halfword	
9	0	1	1	B	L	Offset5					Rb	Rd				Load/store with immediate offset	
10	1	0	0	0	L	Offset5					Rb	Rd				Load/store halfword	
11	1	0	0	1	L	Rd				Word8						SP-relative load/store	
12	1	0	1	0	SP	Rd				Word8						Load address	
13	1	0	1	1	0	0	0	0	S	SWord7						Add offset to stack pointer	
14	1	0	1	1	L	1	0	R	Rlist							Push/pop register	
15	1	1	0	0	L	Rb				Rlist						Multiple load/store	
16	1	1	0	1	Cond					Softset8						Conditional branch	
17	1	1	0	1	1	1	1	1	Value8							Software interrupt	
18	1	1	1	0	0	Offset11										Unconditional branch	
19	1	1	1	1	H	Offset										Long branch with link	

Figure 3-29. THUMB Instruction Set Formats

3.19.2 OPCODE SUMMARY

The following table summarises the THUMB instruction set. For further information about a particular instruction please refer to the sections listed in the right-most column.

Table 3-7. THUMB Instruction Set Opcodes

Mnemonic	Instruction	Lo-Register Operand	Hi-Register Operand	Condition Codes Set
ADC	Add with carry	V	–	V
ADD	Add	V	V	V (1)
AND	AND	V	–	V
ASR	Arithmetic shift right	V	–	V
B	Unconditional branch	V	–	–
Bxx	Conditional branch	V	–	–
BIC	Bit clear	V	–	V
BL	Branch and link	V	–	–
BX	Branch and exchange	V	V	–
CMN	Compare negative	V	–	V
CMP	Compare	V	V	V
EOR	EOR	V	–	V
LDMIA	Load multiple	V	–	–
LDR	Load word	V	–	–
LDRB	Load byte	V	–	–
LDRH	Load half-word	V	–	–
LSL	Logical shift left	V	–	V
LDSB	Load sign-extended byte	V	–	–
LDSH	Load sign-extended half-word	V	–	–
LSR	Logical shift right	V	–	V
MOV	Move register	V	V	V (2)
MUL	Multiply	V	–	V
MVN	Move negative register	V	–	V
NEG	Negate	V	–	V
ORR	OR	V	–	V
POP	Pop registers	V	–	–
PUSH	Push registers	V	–	–
POR	Rotate right	V	–	V

Table 3-7. THUMB Instruction Set Opcodes (Continued)

Mnemonic	Instruction	Lo-Register Operand	Hi-Register Operand	Condition Codes Set
SBC	Subtract with carry	V	–	V
STMIA	Store multiple	V	–	–
STR	Store word	V	–	–
STRB	Store byte	V	–	–
STRH	Store half-word	V	–	–
SWI	Software interrupt	–	–	–
SUB	Subtract	V	–	V
TST	Test bits	V	–	V

NOTES:

1. The condition codes are unaffected by the format 5, 12 and 13 versions of this instruction.
2. The condition codes are unaffected by the format 5 version of this instruction.

3.20 FORMAT 1: MOVE SHIFTED REGISTER

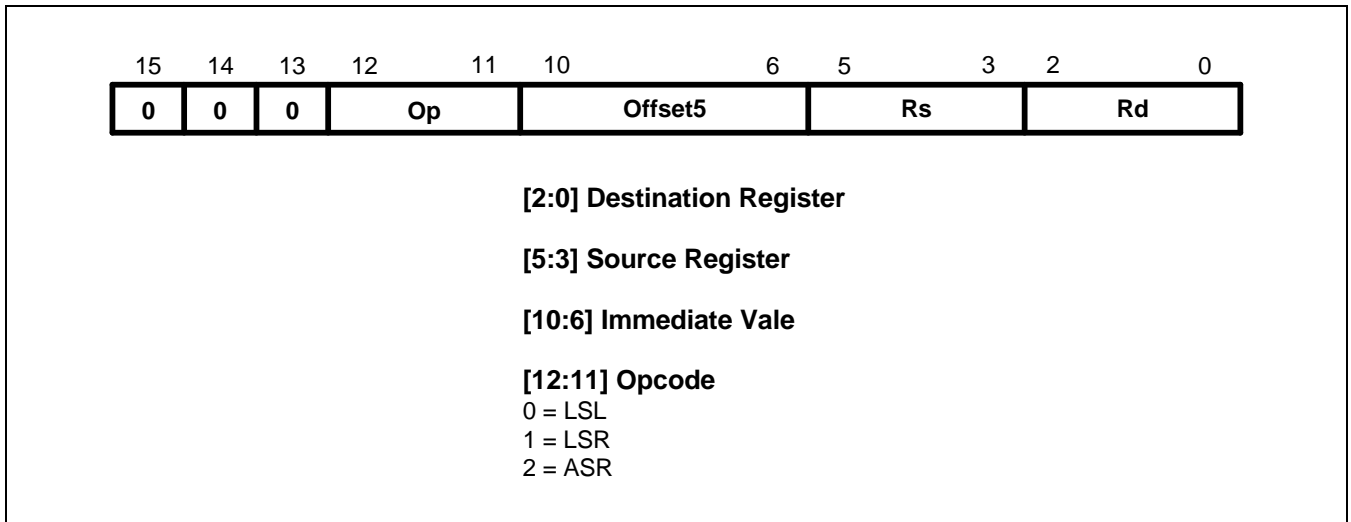

Figure 3-30. Format 1

3.20.1 OPERATION

These instructions move a shifted value between Lo registers. The THUMB assembler syntax is shown in Table 3-8.

NOTE

All instructions in this group set the CPSR condition codes.

Table 3-8. Summary of Format 1 Instructions

OP	THUMB Assembler	ARM Equivalent	Action
00	LSL Rd, Rs, #Offset5	MOVS Rd, Rs, LSL #Offset5	Shift Rs left by a 5-bit immediate value and store the result in Rd.
01	LSR Rd, Rs, #Offset5	MOVS Rd, Rs, LSR #Offset5	Perform logical shift right on Rs by a 5-bit immediate value and store the result in Rd.
10	ASR Rd, Rs, #Offset5	MOVS Rd, Rs, ASR #Offset5	Perform arithmetic shift right on Rs by a 5-bit immediate value and store the result in Rd.

3.20.2 INSTRUCTION CYCLE TIMES

All instructions in this format have an equivalent ARM instruction as shown in Table 3-8. The instruction cycle times for the THUMB instruction are identical to that of the equivalent ARM instruction.

Examples

```

LSR      R2, R5, #27      ; Logical shift right the contents
                        ; of R5 by 27 and store the result in R2.
                        ; Set condition codes on the result.
  
```

3.21 FORMAT 2: ADD/SUBTRACT

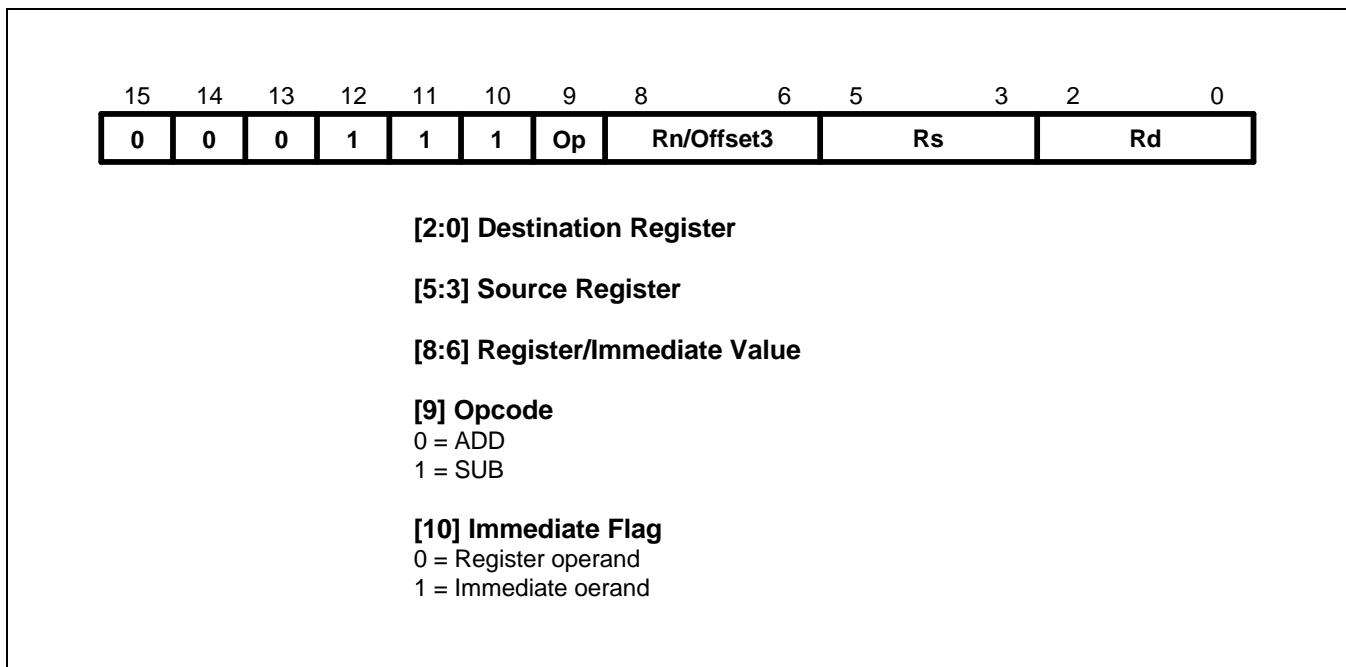

Figure 3-31. Format 2

3.21.1 OPERATION

These instructions allow the contents of a Lo register or a 3-bit immediate value to be added to or subtracted from a Lo register. The THUMB assembler syntax is shown in Table 3-9.

NOTE

All instructions in this group set the CPSR condition codes.

Table 3-9. Summary of Format 2 Instructions

OP	I	THUMB Assembler	ARM Equivalent	Action
0	0	ADD Rd, Rs, Rn	ADDS Rd, Rs, Rn	Add contents of Rn to contents of Rs. Place result in Rd.
0	1	ADD Rd, Rs, #Offset3	ADDS Rd, Rs, #Offset3	Add 3-bit immediate value to contents of Rs. Place result in Rd.
1	0	SUB Rd, Rs, Rn	SUBS Rd, Rs, Rn	Subtract contents of Rn from contents of Rs. Place result in Rd.
1	1	SUB Rd, Rs, #Offset3	SUBS Rd, Rs, #Offset3	Subtract 3-bit immediate value from contents of Rs. Place result in Rd.

3.21.2 INSTRUCTION CYCLE TIMES

All instructions in this format have an equivalent ARM instruction as shown in Table 3-9. The instruction cycle times for the THUMB instruction are identical to that of the equivalent ARM instruction.

Examples

ADD	R0, R3, R4	; R0 := R3 + R4 and set condition codes on the result.
SUB	R6, R2, #6	; R6 := R2 - 6 and set condition codes.

3.22 FORMAT 3: MOVE/COMPARE/ADD/SUBTRACT IMMEDIATE

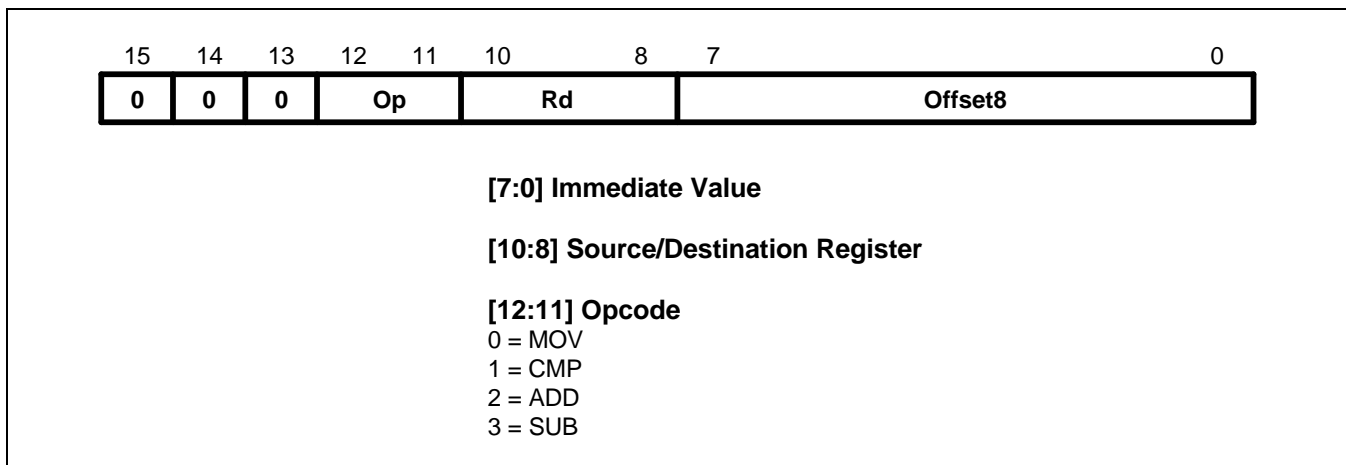

Figure 3-32. Format 3

3.22.1 OPERATIONS

The instructions in this group perform operations between a Lo register and an 8-bit immediate value. The THUMB assembler syntax is shown in Table 3-10.

NOTE

All instructions in this group set the CPSR condition codes.

Table 3-10. Summary of Format 3 Instructions

OP	THUMB Assembler	ARM Equivalent	Action
00	MOV Rd, #Offset8	MOVS Rd, #Offset8	Move 8-bit immediate value into Rd.
01	CMP Rd, #Offset8	CMP Rd, #Offset8	Compare contents of Rd with 8-bit immediate value.
10	ADD Rd, #Offset8	ADDS Rd, Rd, #Offset8	Add 8-bit immediate value to contents of Rd and place the result in Rd.
11	SUB Rd, #Offset8	SUBS Rd, Rd, #Offset8	Subtract 8-bit immediate value from contents of Rd and place the result in Rd.

3.22.2 INSTRUCTION CYCLE TIMES

All instructions in this format have an equivalent ARM instruction as shown in Table 3-10. The instruction cycle times for the THUMB instruction are identical to that of the equivalent ARM instruction.

Examples

MOV	R0, #128		; R0 := 128 and set condition codes
CMP	R2, #62		; Set condition codes on R2 - 62
ADD	R1, #255		; R1 := R1 + 255 and set condition codes
SUB	R6, #145		; R6 := R6 - 145 and set condition codes

3.23 FORMAT 4: ALU OPERATIONS

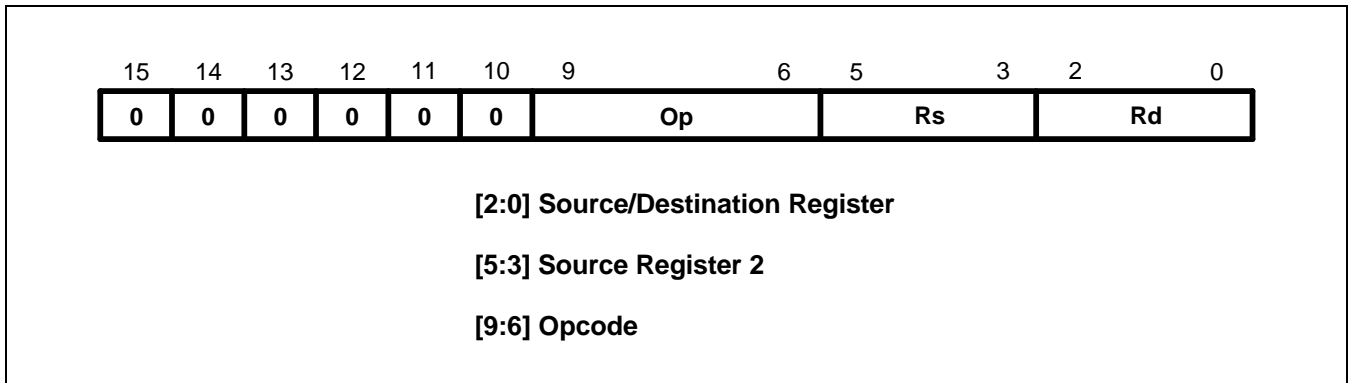

Figure 3-33. Format 4

3.23.1 OPERATION

The following instructions perform ALU operations on a Lo register pair.

NOTE

All instructions in this group set the CPSR condition codes

Table 3-11. Summary of Format 4 Instructions

OP	THUMB Assembler	ARM Equivalent	Action
0000	AND Rd, Rs	ANDS Rd, Rd, Rs	Rd : = Rd AND Rs
0001	EOR Rd, Rs	EORS Rd, Rd, Rs	Rd : = Rd EOR Rs
0010	LSL Rd, Rs	MOVS Rd, Rd, LSL Rs	Rd : = Rd << Rs
0011	LSR Rd, Rs	MOVS Rd, Rd, LSR Rs	Rd : = Rd >> Rs
0100	ASR Rd, Rs	MOVS Rd, Rd, ASR Rs	Rd : = Rd ASR Rs
0101	ADC Rd, Rs	ADCS Rd, Rd, Rs	Rd : = Rd + Rs + C-bit
0110	SBC Rd, Rs	SBCS Rd, Rd, Rs	Rd : = Rd - Rs - NOT C-bit
0111	ROR Rd, Rs	MOVS Rd, Rd, ROR Rs	Rd : = Rd ROR Rs
1000	TST Rd, Rs	TST Rd, Rs	Set condition codes on Rd AND Rs
1001	NEG Rd, Rs	RSBS Rd, Rs, #0	Rd = - Rs
1010	CMP Rd, Rs	CMP Rd, Rs	Set condition codes on Rd - Rs
1011	CMN Rd, Rs	CMN Rd, Rs	Set condition codes on Rd + Rs
1100	ORR Rd, Rs	ORRS Rd, Rd, Rs	Rd : = Rd OR Rs
1101	MUL Rd, Rs	MULS Rd, Rs, Rd	Rd : = Rs * Rd
1110	BIC Rd, Rs	BICS Rd, Rd, Rs	Rd : = Rd AND NOT Rs
1111	MVN Rd, Rs	MVNS Rd, Rs	Rd : = NOT Rs

3.23.2 INSTRUCTION CYCLE TIMES

All instructions in this format have an equivalent ARM instruction as shown in Table 3-11. The instruction cycle times for the THUMB instruction are identical to that of the equivalent ARM instruction.

Examples

EOR	R3, R4	; R3 := R3 EOR R4 and set condition codes
ROR	R1, R0	; Rotate right R1 by the value in R0, store ; the result in R1 and set condition codes
NEG	R5, R3	; Subtract the contents of R3 from zero, ; store the result in R5. Set condition codes ie R5 = - R3
CMP	R2, R6	; Set the condition codes on the result of R2 - R6
MUL	R0, R7	; R0 := R7 * R0 and set condition codes

3.24 FORMAT 5: HI-REGISTER OPERATIONS/BRANCH EXCHANGE

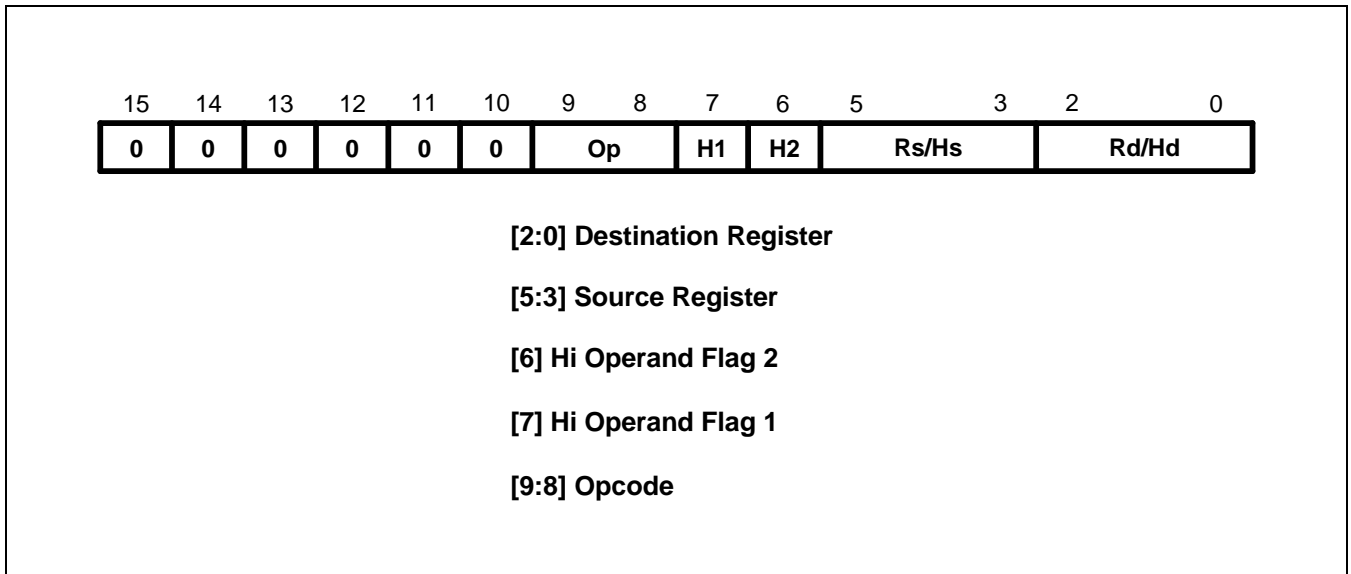

Figure 3-34. Format 5

3.24.1 OPERATION

There are four sets of instructions in this group. The first three allow ADD, CMP and MOV operations to be performed between Lo and Hi registers, or a pair of Hi registers. The fourth, BX, allows a Branch to be performed which may also be used to switch processor state. The THUMB assembler syntax is shown in Table 3-12.

NOTE

In this group only CMP (Op = 01) sets the CPSR condition codes.

The action of H1 = 0, H2 = 0 for Op = 00 (ADD), Op = 01 (CMP) and Op = 10 (MOV) is undefined, and should not be used.

Table 3-12. Summary of Format 5 Instructions

OP	H1	H2	THUMB Assembler	ARM Equivalent	Action
00	0	1	ADD Rd, Hs	ADD Rd, Rd, Hs	Add a register in the range 8-15 to a register in the range 0-7.
00	1	0	ADD Hd, Rs	ADD Hd, Hd, Rs	Add a register in the range 0-7 to a register in the range 8-15.
00	1	1	ADD Hd, Hs	ADD Hd, Hd, Hs	Add two registers in the range 8-15.
01	0	1	CMP Rd, Hs	CMP Rd, Hs	Compare a register in the range 0-7 with a register in the range 8-15. Set the condition code flags on the result.
01	1	0	CMP Hd, Rs	CMP Hd, Rs	Compare a register in the range 8-15 with a register in the range 0-7. Set the condition code flags on the result.
01	1	1	CMP Hd, Hs	CMP Hd, Hs	Compare two registers in the range 8-15. Set the condition code flags on the result.
10	0	1	MOV Rd, Hs	MOV Rd, Hs	Move a value from a register in the range 8-15 to a register in the range 0-7.
10	1	0	MOV Hd, Rs	MOV Hd, Rs	Move a value from a register in the range 0-7 to a register in the range 8-15.
00	0	1	MOV Hd, Hs	MOV Hd, Hs	Move a value between two registers in the range 8-15.
00	1	0	BX Rs	BX Rs	Perform branch (plus optional state change) to address in a register in the range 0-7.
00	1	1	BX Hs	BX Hs	Perform branch (plus optional state change) to address in a register in the range 8-15.

3.24.2 INSTRUCTION CYCLE TIMES

All instructions in this format have an equivalent ARM instruction as shown in Table 3-12. The instruction cycle times for the THUMB instruction are identical to that of the equivalent ARM instruction.

3.24.3 THE BX INSTRUCTION

BX performs a branch to a routine whose start address is specified in a Lo or Hi register.

Bit 0 of the address determines the processor state on entry to the routine:

- Bit 0 = 0 Causes the processor to enter ARM state.
- Bit 0 = 1 Causes the processor to enter THUMB state.

NOTE

The action of H1 = 1 for this instruction is undefined, and should not be used.

Examples

Hi-Register Operations

```

ADD    PC, R5           ; PC := PC + R5 but don't set the condition codes.CMP
R4, R12                ; Set the condition codes on the result of R4 - R12.
MOV    R15, R14        ; Move R14 (LR) into R15 (PC)
                          ; but don't set the condition codes,
                          ; eg. return from subroutine.

```

Branch and Exchange

```

ADR    R1,outofTHUMB    ; Switch from THUMB to ARM state.
MOV    R11,R1           ; Load address of outofTHUMB into R1.
BX    R11               ; Transfer the contents of R11 into the PC.
                          ; Bit 0 of R11 determines whether
                          ; ARM or THUMB state is entered, ie. ARM state here.
...
ALIGN
CODE32
outofTHUMB              ; Now processing ARM instructions...

```

3.24.4 USING R15 AS AN OPERAND

If R15 is used as an operand, the value will be the address of the instruction + 4 with bit 0 cleared. Executing a BX PC in THUMB state from a non-word aligned address will result in unpredictable execution.

3.25 FORMAT 6: PC-RELATIVE LOAD

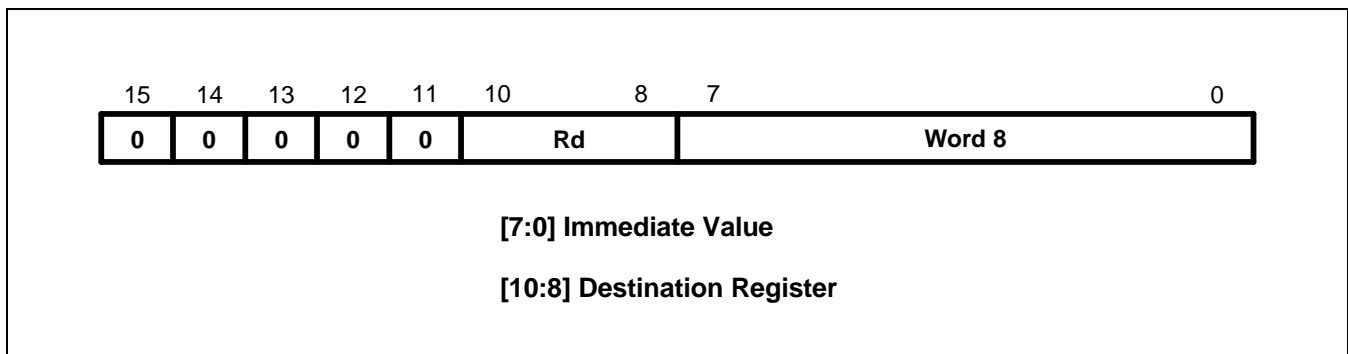

Figure 3-35. Format 6

3.25.1 OPERATION

This instruction loads a word from an address specified as a 10-bit immediate offset from the PC. The THUMB assembler syntax is shown below.

Table 3-13. Summary of PC-Relative Load Instruction

THUMB Assembler	ARM Equivalent	Action
LDR Rd, [PC, #Imm]	LDR Rd, [R15, #Imm]	Add unsigned offset (255 words, 1020 bytes) in Imm to the current value of the PC. Load the word from the resulting address into Rd.

NOTE: The value specified by #Imm is a full 10-bit address, but must always be word-aligned (ie with bits 1:0 set to 0), since the assembler places #Imm >> 2 in field Word 8. The value of the PC will be 4 bytes greater than the address of this instruction, but bit 1 of the PC is forced to 0 to ensure it is word aligned.

3.25.2 INSTRUCTION CYCLE TIMES

All instructions in this format have an equivalent ARM instruction. The instruction cycle times for the THUMB instruction are identical to that of the equivalent ARM instruction.

Examples

```
LDR R3,[PC,#844] ; Load into R3 the word found at the
                  ; address formed by adding 844 to PC.
                  ; bit[1] of PC is forced to zero.
                  ; Note that the THUMB opcode will contain
                  ; 211 as the Word8 value.
```

3.26 FORMAT 7: LOAD/STORE WITH REGISTER OFFSET

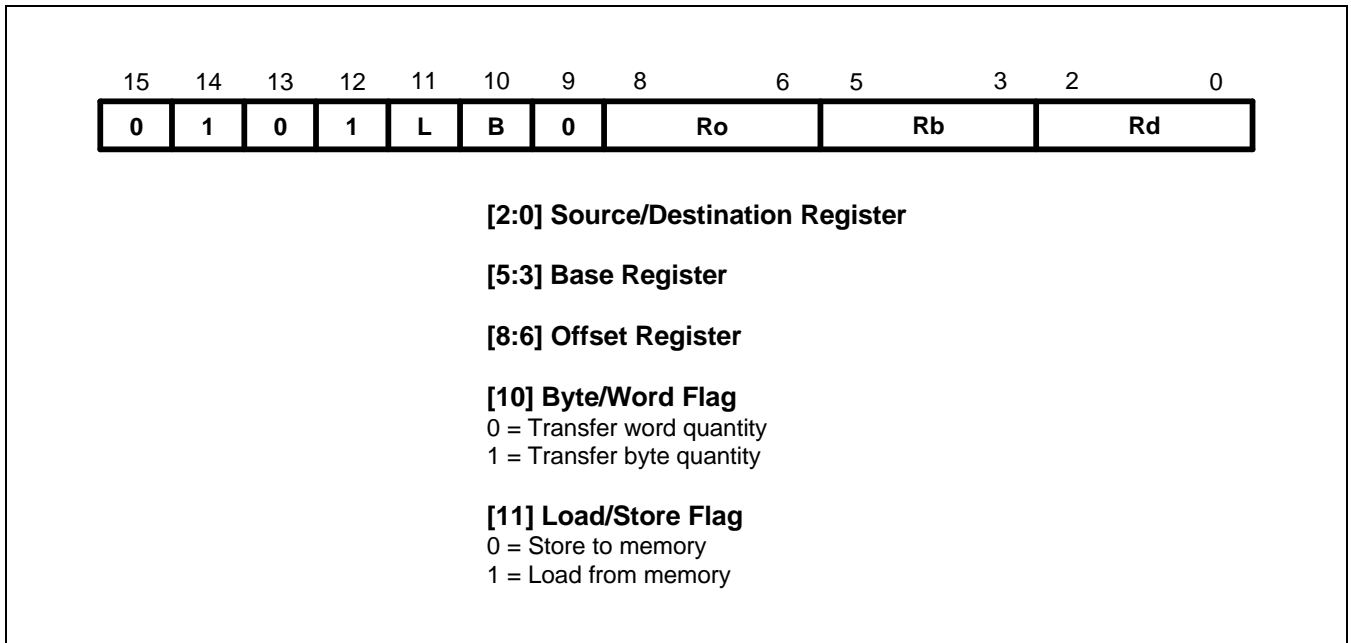

Figure 3-36. Format 7

3.26.1 OPERATION

These instructions transfer byte or word values between registers and memory. Memory addresses are pre-indexed using an offset register in the range 0-7. The THUMB assembler syntax is shown in Table 3-14.

Table 3-14. Summary of Format 7 Instructions

L	B	THUMB Assembler	ARM Equivalent	Action
0	0	STR Rd, [Rb, Ro]	STR Rd, [Rb, Ro]	Pre-indexed word store: Calculate the target address by adding together the value in Rb and the value in Ro. Store the contents of Rd at the address.
0	1	STRB Rd, [Rb, Ro]	STRB Rd, [Rb, Ro]	Pre-indexed byte store: Calculate the target address by adding together the value in Rb and the value in Ro. Store the byte value in Rd at the resulting address.
1	0	LDR Rd, [Rb, Ro]	LDR Rd, [Rb, Ro]	Pre-indexed word load: Calculate the source address by adding together the value in Rb and the value in Ro. Load the contents of the address into Rd.
1	1	LDRB Rd, [Rb, Ro]	LDRB Rd, [Rb, Ro]	Pre-indexed byte load: Calculate the source address by adding together the value in Rb and the value in Ro. Load the byte value at the resulting address.

3.26.2 INSTRUCTION CYCLE TIMES

All instructions in this format have an equivalent ARM instruction as shown in Table 3-14. The instruction cycle times for the THUMB instruction are identical to that of the equivalent ARM instruction.

Examples

STR	R3, [R2,R6]	; Store word in R3 at the address
		; formed by adding R6 to R2.
LDRB	R2, [R0,R7]	; Load into R2 the byte found at
		; the address formed by adding R7 to R0.

3.27 FORMAT 8: LOAD/STORE SIGN-EXTENDED BYTE/HALF-WORD

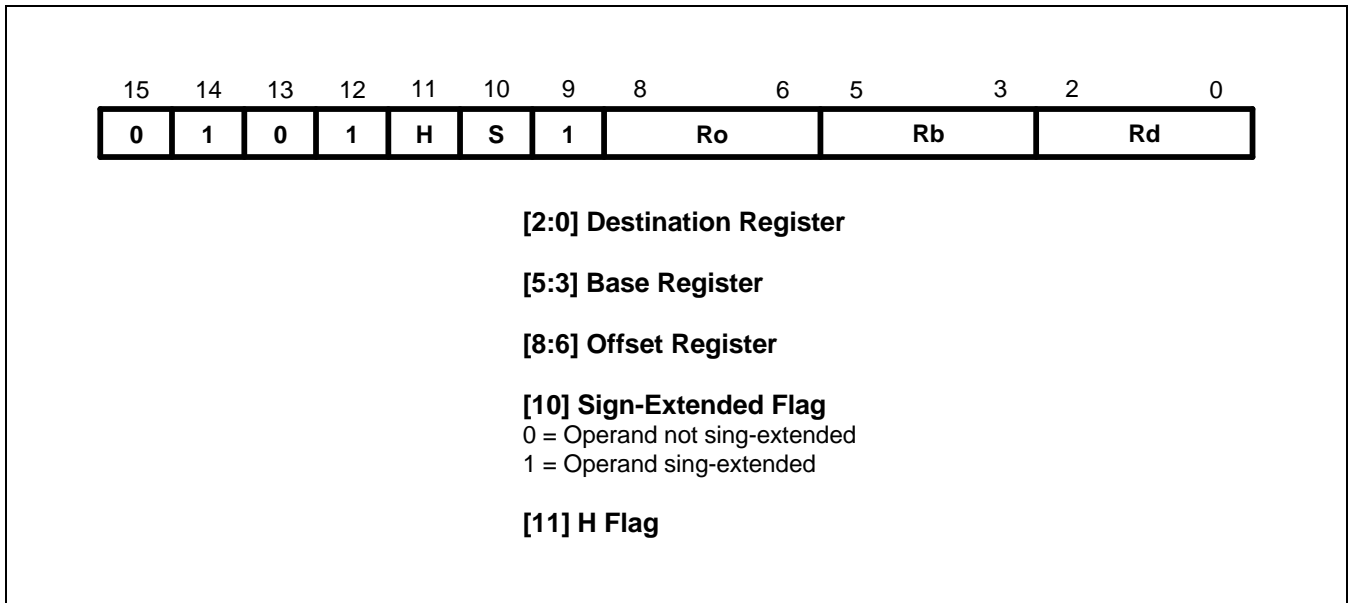

Figure 3-37. Format 8

3.27.1 OPERATION

These instructions load optionally sign-extended bytes or half-words, and store half-words. The THUMB assembler syntax is shown below.

Table 3-15. Summary of format 8 instructions

L	B	THUMB Assembler	ARM Equivalent	Action
0	0	STRH Rd, [Rb, Ro]	STRH Rd, [Rb, Ro]	Store half-word: Add Ro to base address in Rb. Store bits 0–15 of Rd at the resulting address.
0	1	LDRH Rd, [Rb, Ro]	LDRH Rd, [Rb, Ro]	Load half-word: Add Ro to base address in Rb. Load bits 0–15 of Rd from the resulting address, and set bits 16-31 of Rd to 0.
1	0	LDSB Rd, [Rb, Ro]	LDRSB Rd, [Rb, Ro]	Load sign-extended byte: Add Ro to base address in Rb. Load bits 0–7 of Rd from the resulting address, and set bits 8-31 of Rd to bit 7.
1	1	LDSH Rd, [Rb, Ro]	LDRSH Rd, [Rb, Ro]	Load sign-extended half-word: Add Ro to base address in Rb. Load bits 0–15 of Rd from the resulting address, and set bits 16-31 of Rd to bit 15.

3.27.2 INSTRUCTION CYCLE TIMES

All instructions in this format have an equivalent ARM instruction as shown in Table 3-15. The instruction cycle times for the THUMB instruction are identical to that of the equivalent ARM instruction.

Examples

STRH	R4, [R3, R0]	; Store the lower 16 bits of R4 at the ; address formed by adding R0 to R3.
LDSB	R2, [R7, R1]	; Load into R2 the sign extended byte ; found at the address formed by adding R1 to R7.
LDSH	R3, [R4, R2]	; Load into R3 the sign extended half-word ; found at the address formed by adding R2 to R4.

3.28 FORMAT 9: LOAD/STORE WITH IMMEDIATE OFFSET

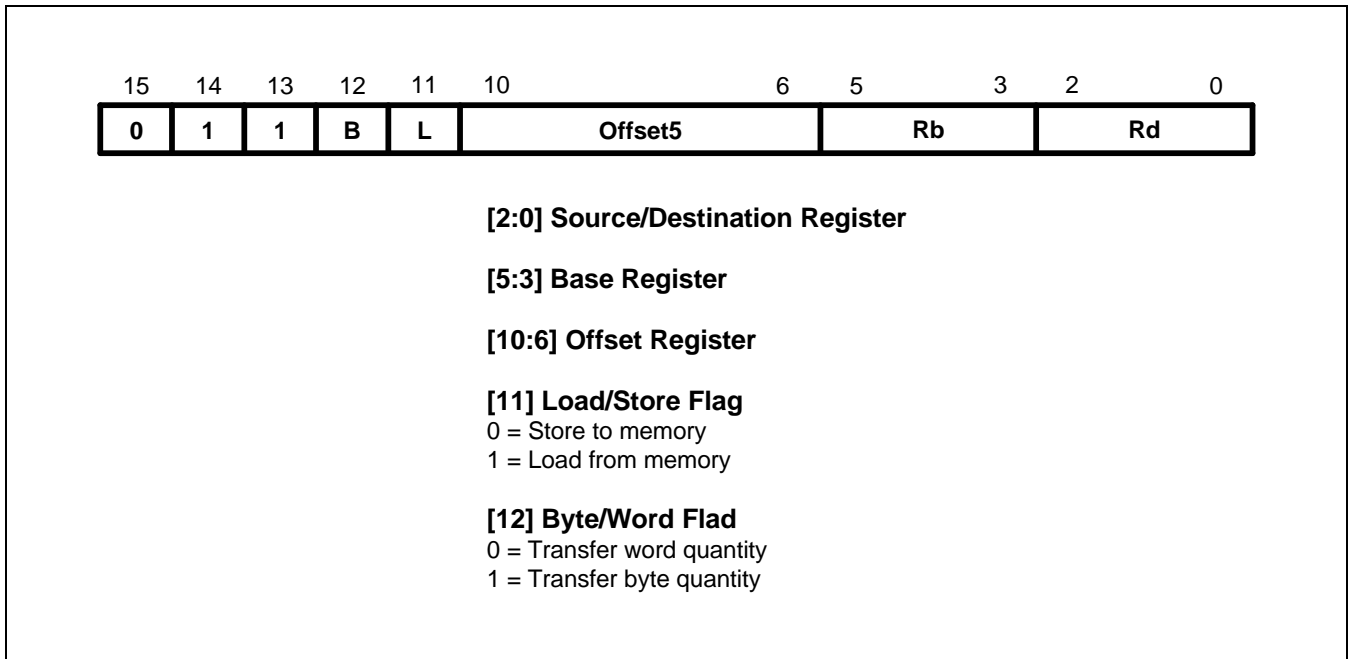

Figure 3-38. Format 9

3.28.1 OPERATION

These instructions transfer byte or word values between registers and memory using an immediate 5 or 7-bit offset. The THUMB assembler syntax is shown in Table 3-16

Table 3-16. Summary of Format 9 Instructions

L	B	THUMB Assembler	ARM Equivalent	Action
0	0	STR Rd, [Rb, #Imm]	STR Rd, [Rb, #Imm]	Calculate the target address by adding together the value in Rb and Imm. Store the contents of Rd at the address.
0	1	LDR Rd, [Rb, #Imm]	LDR Rd, [Rb, #Imm]	Calculate the source address by adding together the value in Rb and Imm. Load Rd from the address.
1	0	STRB Rd, [Rb, #Imm]	STRB Rd, [Rb, #Imm]	Calculate the target address by adding together the value in Rb and Imm. Store the byte value in Rd at the address.
1	1	LDRB Rd, [Rb, #Imm]	LDRB Rd, [Rb, #Imm]	Calculate source address by adding together the value in Rb and Imm. Load the byte value at the address into Rd.

NOTE: For word accesses (B = 0), the value specified by #Imm is a full 7-bit address, but must be word-aligned (ie with bits 1:0 set to 0), since the assembler places #Imm >> 2 in the Offset5 field.

3.28.2 INSTRUCTION CYCLE TIMES

All instructions in this format have an equivalent ARM instruction as shown in Table 3-16. The instruction cycle times for the THUMB instruction are identical to that of the equivalent ARM instruction.

Examples

LDR	R2, [R5,#116]	; Load into R2 the word found at the ; address formed by adding 116 to R5. ; Note that the THUMB opcode will ; contain 29 as the Offset5 value.
STRB	R1, [R0,#13]	; Store the lower 8 bits of R1 at the ; address formed by adding 13 to R0. ; Note that the THUMB opcode will ; contain 13 as the Offset5 value.

3.29 FORMAT 10: LOAD/STORE HALF-WORD

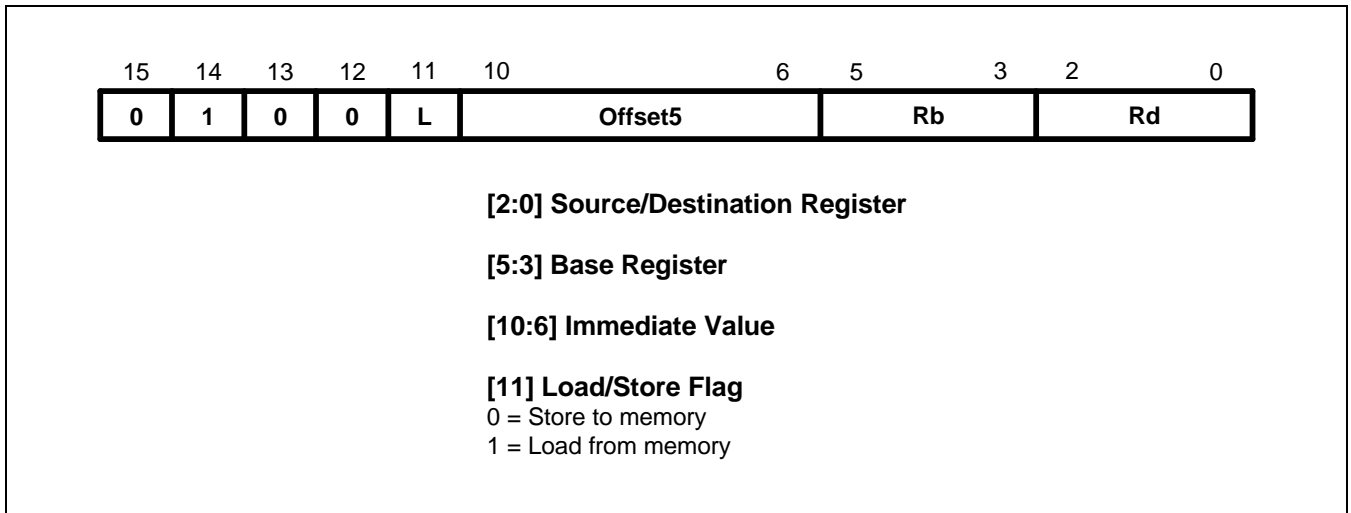

Figure 3-39. Format 10

3.29.1 OPERATION

These instructions transfer half-word values between a Lo register and memory. Addresses are pre-indexed, using a 6-bit immediate value. The THUMB assembler syntax is shown in Table 3-17.

Table 3-17. Half-word Data Transfer Instructions

L	THUMB Assembler	ARM Equivalent	Action
0	STRH Rd, [Rb, #Imm]	STRH Rd, [Rb, #Imm]	Add #Imm to base address in Rb and store bits 0–15 of Rd at the resulting address.
1	LDRH Rd, [Rb, #Imm]	LDRH Rd, [Rb, #Imm]	Add #Imm to base address in Rb. Load bits 0–15 from the resulting address into Rd and set bits 16–31 to zero.

NOTE: #Imm is a full 6-bit address but must be half-word-aligned (ie with bit 0 set to 0), since the assembler places #Imm >> 1 in the Offset5 field.

3.29.2 INSTRUCTION CYCLE TIMES

All instructions in this format have an equivalent ARM instruction as shown in Table 3-17. The instruction cycle times for the THUMB instruction are identical to that of the equivalent ARM instruction.

Examples

STRH	R6, [R1, #56]	; Store the lower 16 bits of R4 at the address formed by ; adding 56 R1. Note that the THUMB opcode will contain ; 28 as the Offset5 value.
LDRH	R4, [R7, #4]	; Load into R4 the half-word found at the address formed by ; adding 4 to R7. Note that the THUMB opcode will ; contain 2 as the Offset5 value.

3.30 FORMAT 11: SP-RELATIVE LOAD/STORE

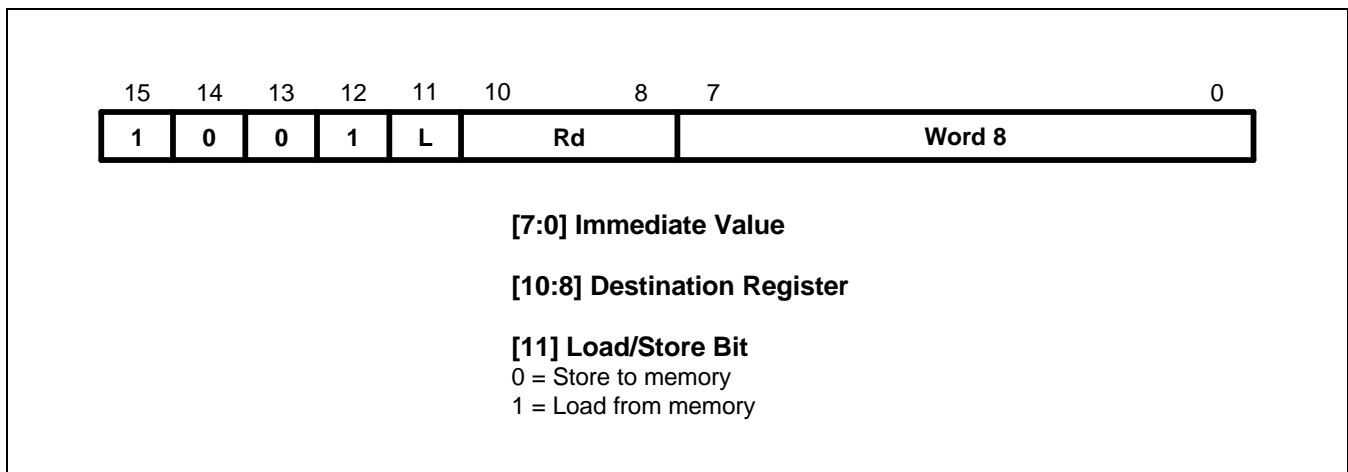

Figure 3-40. Format 11

3.30.1 OPERATION

The instructions in this group perform an SP-relative load or store. The THUMB assembler syntax is shown in the following table.

Table 3-18. SP-Relative Load/Store Instructions

L	THUMB Assembler	ARM Equivalent	Action
0	STR Rd, [SP, #Imm]	STR Rd, [R13 #Imm]	Add unsigned offset (255 words, 1020 bytes) in Imm to the current value of the SP (R7). Store the contents of Rd at the resulting address.
1	LDR Rd, [SP, #Imm]	LDR Rd, [R13 #Imm]	Add unsigned offset (255 words, 1020 bytes) in Imm to the current value of the SP (R7). Load the word from the resulting address into Rd.

NOTE: The offset supplied in #Imm is a full 10-bit address, but must always be word-aligned (ie bits 1:0 set to 0), since the assembler places #Imm >> 2 in the Word8 field.

3.30.2 INSTRUCTION CYCLE TIMES

All instructions in this format have an equivalent ARM instruction as shown in Table 3-18. The instruction cycle times for the THUMB instruction are identical to that of the equivalent ARM instruction.

Examples

```

STR      R4, [SP,#492]      ; Store the contents of R4 at the address
                                ; formed by adding 492 to SP (R13).
                                ; Note that the THUMB opcode will contain
                                ; 123 as the Word8 value.
  
```

3.31 FORMAT 12: LOAD ADDRES

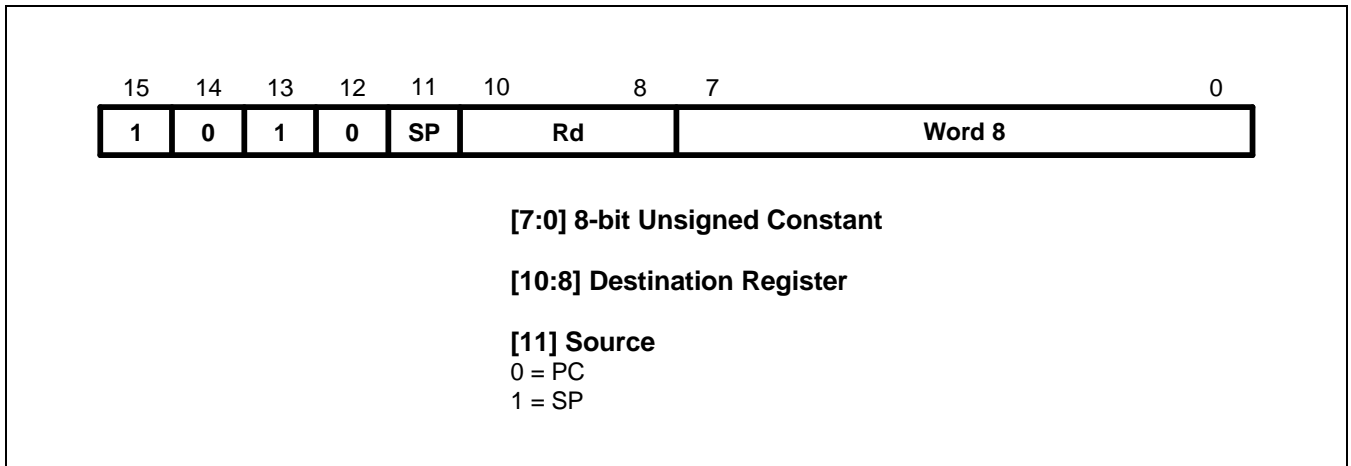

Figure 3-41. Format 12

3.31.1 OPERATION

These instructions calculate an address by adding an 10-bit constant to either the PC or the SP, and load the resulting address into a register. The THUMB assembler syntax is shown in the following table.

Table 3-19. Load Address

SP	THUMB Assembler	ARM Equivalent	Action
0	ADD Rd, PC, #Imm	ADD Rd, R15, #Imm	Add #Imm to the current value of the program counter (PC) and load the result into Rd.
1	ADD Rd, SP, #Imm	ADD Rd, R13, #Imm	Add #Imm to the current value of the stack pointer (SP) and load the result into Rd.

NOTE: The value specified by #Imm is a full 10-bit value, but this must be word-aligned (ie with bits 1:0 set to 0) since the assembler places #Imm >> 2 in field Word 8.

Where the PC is used as the source register (SP = 0), bit 1 of the PC is always read as 0. The value of the PC will be 4 bytes greater than the address of the instruction before bit 1 is forced to 0.

The CPSR condition codes are unaffected by these instructions.

3.31.2 INSTRUCTION CYCLE TIMES

All instructions in this format have an equivalent ARM instruction as shown in Table 3-19. The instruction cycle times for the THUMB instruction are identical to that of the equivalent ARM instruction.

Examples

ADD	R2, PC, #572	; R2: = PC + 572, but don't set the ; condition codes. bit[1] of PC is forced to zero. ; Note that the THUMB opcode will ; contain 143 as the Word8 value.
ADD	R6, SP, #212	; R6: = SP (R13) + 212, but don't ; set the condition codes. ; Note that the THUMB opcode will ; contain 53 as the Word 8 value.

3.32 FORMAT 13: ADD OFFSET TO STACK POINTER

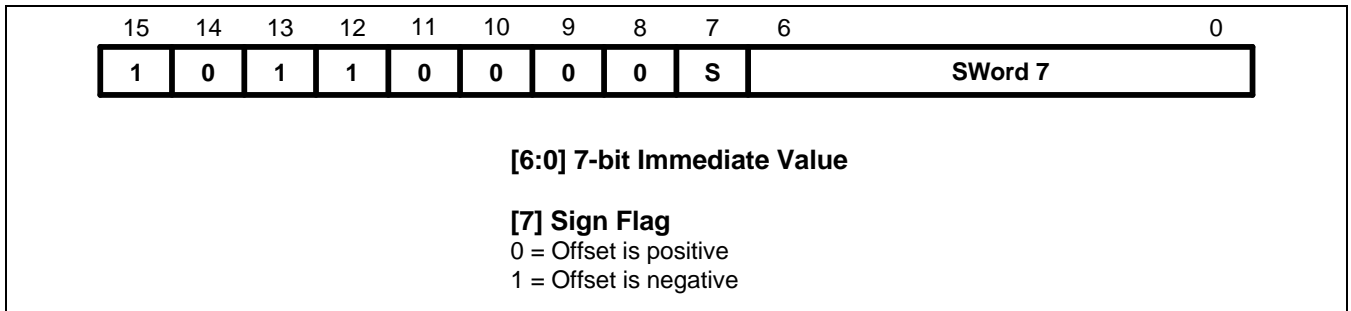

Figure 3-42. Format 13

3.32.1 OPERATION

This instruction adds a 9-bit signed constant to the stack pointer. The following table shows the THUMB assembler syntax.

Table 3-20. The ADD SP Instruction

S	THUMB Assembler	ARM Equivalent	Action
0	ADD SP, #Imm	ADD R13, R13, #Imm	Add #Imm to the stack pointer (SP).
1	ADD SP, #-Imm	SUB R13, R13, #Imm	Add #-Imm to the stack pointer (SP).

NOTE: The offset specified by #Imm can be up to +/- 508, but must be word-aligned (ie with bits 1:0 set to 0) since the assembler converts #Imm to an 8-bit sign + magnitude number before placing it in field SWord7. The condition codes are not set by this instruction.

3.32.2 INSTRUCTION CYCLE TIMES

All instructions in this format have an equivalent ARM instruction as shown in Table 3-20. The instruction cycle times for the THUMB instruction are identical to that of the equivalent ARM instruction.

Examples

```

ADD    SP, #268           ; SP (R13): = SP + 268, but don't set the condition codes.
                                ; Note that the THUMB opcode will
                                ; contain 67 as the Word7 value and S = 0.
ADD    SP, #-104          ; SP (R13): = SP - 104, but don't set the condition codes.
                                ; Note that the THUMB opcode will contain
                                ; 26 as the Word7 value and S = 1.

```

3.33.2 INSTRUCTION CYCLE TIMES

All instructions in this format have an equivalent ARM instruction as shown in Table 3-21. The instruction cycle times for the THUMB instruction are identical to that of the equivalent ARM instruction.

Examples

PUSH	{R0–R4,LR}	; Store R0, R1, R2, R3, R4 and R14 (LR) at ; the stack pointed to by R13 (SP) and update R13. ; Useful at start of a sub-routine to ; save workspace and return address.
POP	{R2, R6, PC}	; Load R2, R6 and R15 (PC) from the stack ; pointed to by R13 (SP) and update R13. ; Useful to restore workspace and return from sub-routine.

3.35 FORMAT 16: CONDITIONAL BRANCH

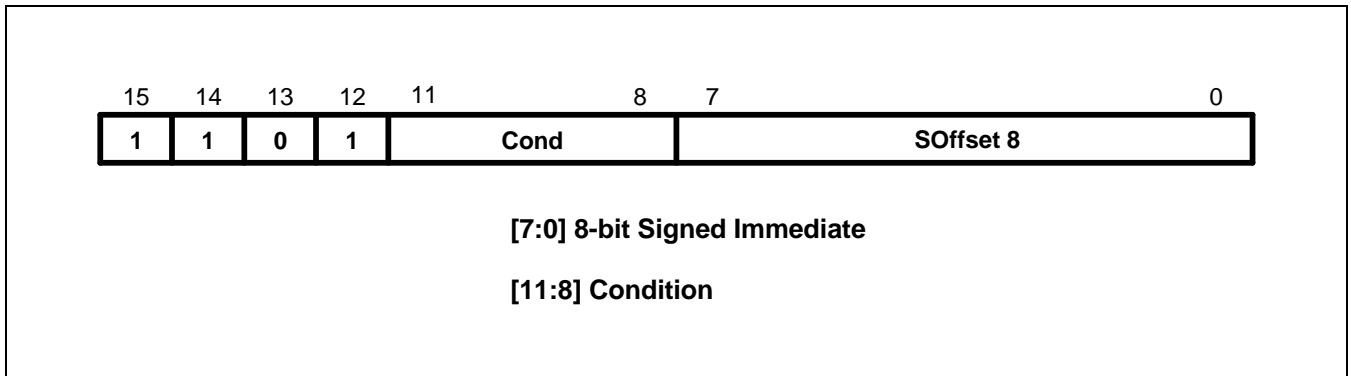

Figure 3-45. Format 16

3.35.1 OPERATION

The instructions in this group all perform a conditional Branch depending on the state of the CPSR condition codes. The branch offset must take account of the prefetch operation, which causes the PC to be 1 word (4 bytes) ahead of the current instruction.

The THUMB assembler syntax is shown in the following table.

Table 3-23. The Conditional Branch Instructions

Code	THUMB Assembler	ARM Equivalent	Action
0000	BEQ label	BEQ label	Branch if Z set (equal)
0001	BNE label	BNE label	Branch if Z clear (not equal)
0010	BCS label	BCS label	Branch if C set (unsigned higher or same)
0011	BCC label	BCC label	Branch if C clear (unsigned lower)
0100	BMI label	BMI label	Branch if N set (negative)
0101	BPL label	BPL label	Branch if N clear (positive or zero)
0110	BVS label	BVS label	Branch if V set (overflow)
0111	BVC label	BVC label	Branch if V clear (no overflow)
1000	BHI label	BHI label	Branch if C set and Z clear (unsigned higher)
1001	BLS label	BLS label	Branch if C clear or Z set (unsigned lower or same)
1010	BGE label	BGE label	Branch if N set and V set, or N clear and V clear (greater or equal)

Table 3-23. The Conditional Branch Instructions (Continued)

Code	THUMB Assembler	ARM Equivalent	Action
1011	BLT label	BLT label	Branch if N set and V clear, or N clear and V set (less than)
1100	BGT label	BGT label	Branch if Z clear, and either N set and V set or N clear and V clear (greater than)
1101	BLE label	BLE label	Branch if Z set, or N set and V clear, or N clear and V set (less than or equal)

NOTES:

1. While label specifies a full 9-bit two's complement address, this must always be half-word-aligned (ie with bit 0 set to 0) since the assembler actually places label >> 1 in field SOffset8.
2. Cond = 1110 is undefined, and should not be used.
Cond = 1111 creates the SWI instruction: see .

3.35.2 INSTRUCTION CYCLE TIMES

All instructions in this format have an equivalent ARM instruction as shown in Table 3-23. The instruction cycle times for the THUMB instruction are identical to that of the equivalent ARM instruction.

Examples

```

        CMP R0, #45           ; Branch to over-if R0 > 45.
        BGT over             ; Note that the THUMB opcode will contain
        ...                 ; the number of half-words to offset.
        ...
over    ...                 ; Must be half-word aligned.
        ...

```

3.36 FORMAT 17: SOFTWARE INTERRUPT

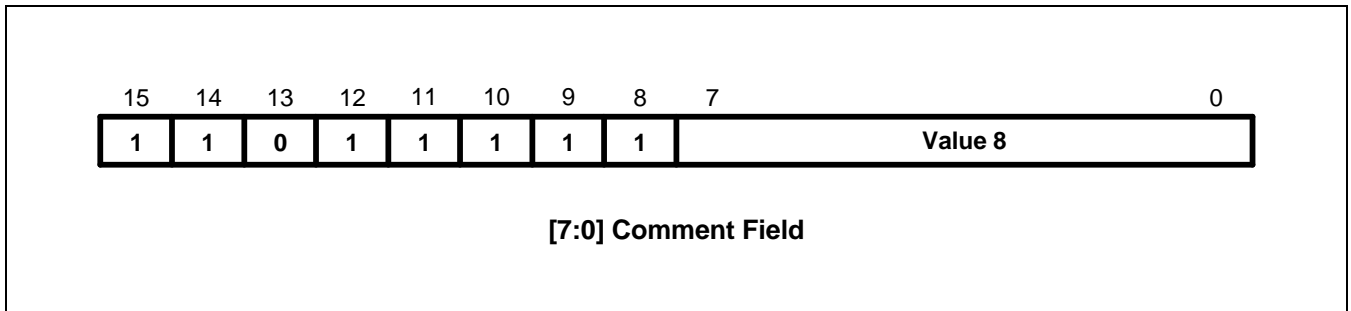

Figure 3-46. Format 17

3.36.1 OPERATION

The SWI instruction performs a software interrupt. On taking the SWI, the processor switches into ARM state and enters Supervisor (SVC) mode.

The THUMB assembler syntax for this instruction is shown below.

Table 3-24. The SWI Instruction

THUMB Assembler	ARM Equivalent	Action
SWI Value 8	SWI Value 8	Perform Software Interrupt: Move the address of the next instruction into LR, move CPSR to SPSR, load the SWI vector address (0x8) into the PC. Switch to ARM state and enter SVC mode.

NOTE: Value 8 is used solely by the SWI handler; it is ignored by the processor.

3.36.2 INSTRUCTION CYCLE TIMES

All instructions in this format have an equivalent ARM instruction as shown in Table 3-24. The instruction cycle times for the THUMB instruction are identical to that of the equivalent ARM instruction.

Examples

```
SWI 18 ; Take the software interrupt exception.
        ; Enter Supervisor mode with 18 as the
        ; requested SWI number.
```

3.37 FORMAT 18: UNCONDITIONAL BRANCH

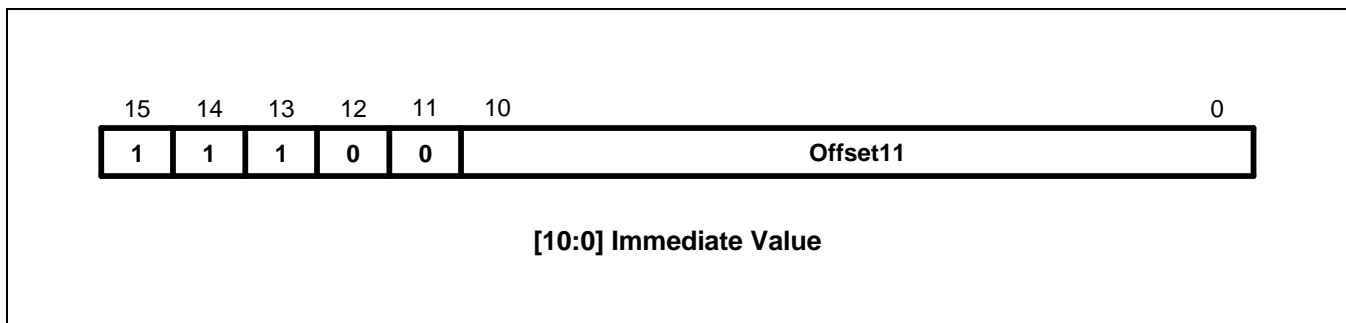

Figure 3-47. Format 18

3.37.1 OPERATION

This instruction performs a PC-relative Branch. The THUMB assembler syntax is shown below. The branch offset must take account of the prefetch operation, which causes the PC to be 1 word (4 bytes) ahead of the current instruction.

Table 3-25. Summary of Branch Instruction

THUMB Assembler	ARM Equivalent	Action
B label	BAL label (half-word offset)	Branch PC relative +/- Offset11 << 1, where label is PC +/- 2048 bytes.

NOTE: The address specified by label is a full 12-bit two's complement address, but must always be half-word aligned (ie bit 0 set to 0), since the assembler places label >> 1 in the Offset11 field.

Examples

```

here      B here          ; Branch onto itself. Assembles to 0xE7FE.
          ; (Note effect of PC offset).
          B jimmy        ; Branch to 'jimmy'.
          ...            ; Note that the THUMB opcode will contain the number of
          ; half-words to offset.
Jimmy    ...            ; Must be half-word aligned.

```

3.38.2 INSTRUCTION CYCLE TIMES

This instruction format does not have an equivalent ARM instruction.

Table 3-26. The BL Instruction

H	THUMB Assembler	ARM Equivalent	Action
0	BL label	none	LR := PC + OffsetHigh << 12
1			temp := next instruction address PC := LR + OffsetLow << 1 LR := temp 1

Examples

```

next      BL faraway      ; Unconditionally Branch to 'faraway'
          ...             ; and place following instruction
          ...             ; address, ie "next" , in R14,the Link
          ...             ; register and set bit 0 of LR high.
          ...             ; Note that the THUMB opcodes will
faraway   ...             ; contain the number of half-words to offset.
          ...             ; Must be Half-word aligned.

```

3.39 INSTRUCTION SET EXAMPLES

The following examples show ways in which the THUMB instructions may be used to generate small and efficient code. Each example also shows the ARM equivalent so these may be compared.

3.39.1 MULTIPLICATION BY A CONSTANT USING SHIFTS AND ADDS

The following shows code to multiply by various constants using 1, 2 or 3 Thumb instructions alongside the ARM equivalents. For other constants it is generally better to use the built-in MUL instruction rather than using a sequence of 4 or more instructions.

Thumb	ARM
1. Multiplication by 2^n (1,2,4,8,...)	
LSL Ra, Rb, LSL #n	; MOV Ra, Rb, LSL #n
2. Multiplication by 2^{n+1} (3,5,9,17,...)	
LSL Rt, Rb, #n	; ADD Ra, Rb, Rb, LSL #n
ADD Ra, Rt, Rb	
3. Multiplication by 2^{n-1} (3,7,15,...)	
LSL Rt, Rb, #n	; RSB Ra, Rb, Rb, LSL #n
SUB Ra, Rt, Rb	
4. Multiplication by -2^n (-2, -4, -8, ...)	
LSL Ra, Rb, #n	; MOV Ra, Rb, LSL #n
MVN Ra, Ra	; RSB Ra, Ra, #0
5. Multiplication by -2^{n-1} (-3, -7, -15, ...)	
LSL Rt, Rb, #n	; SUB Ra, Rb, Rb, LSL #n
SUB Ra, Rb, Rt	

Multiplication by any $C = \{2^{n+1}, 2^{n-1}, -2^n \text{ or } -2^{n-1}\} * 2^n$

Effectively this is any of the multiplications in 2 to 5 followed by a final shift. This allows the following additional constants to be multiplied. 6, 10, 12, 14, 18, 20, 24, 28, 30, 34, 36, 40, 48, 56, 60, 62

(2..5)		; (2..5)
LSL Ra, Ra, #n		; MOV Ra, Ra, LSL #n

3.39.2 GENERAL PURPOSE SIGNED DIVIDE

This example shows a general purpose signed divide and remainder routine in both Thumb and ARM code.

3.39.2.1 Thumb code

```

;signed_divide                                ; Signed divide of R1 by R0: returns quotient in R0,
                                                ; remainder in R1

;Get abs value of R0 into R3
    ASR    R2, R0, #31                        ; Get 0 or -1 in R2 depending on sign of R0
    EOR    R0, R2                            ; EOR with -1 (0xFFFFFFFF) if negative
    SUB    R3, R0, R2                        ; and ADD 1 (SUB -1) to get abs value

;SUB always sets flag so go & report division by 0 if necessary
    BEQ    divide_by_zero

;Get abs value of R1 by xoring with 0xFFFFFFFF and adding 1 if negative
    ASR    R0, R1, #31                        ; Get 0 or -1 in R3 depending on sign of R1
    EOR    R1, R0                            ; EOR with -1 (0xFFFFFFFF) if negative
    SUB    R1, R0                            ; and ADD 1 (SUB -1) to get abs value

;Save signs (0 or -1 in R0 & R2) for later use in determining ; sign of quotient & remainder.
    PUSH    {R0, R2}

;Justification, shift 1 bit at a time until divisor (R0 value) ; is just <= than dividend (R1 value). To do this shift
;dividend ; right by 1 and stop as soon as shifted value becomes >.
    LSR    R0, R1, #1
    MOV    R2, R3
    B      %FT0
just_l  LSL    R2, #1
0      CMP    R2, R0
    BLS    just_l
    MOV    R0, #0                            ; Set accumulator to 0
    B      %FT0                            ; Branch into division loop
div_l  LSR    R2, #1
0      CMP    R1, R2                        ; Test subtract
    BCC    %FT0
    SUB    R1, R2                            ; If successful do a real subtract
0      ADC    R0, R0                        ; Shift result and add 1 if subtract succeeded
    CMP    R2, R3                            ; Terminate when R2 == R3 (ie we have just
    BNE    div_l                            ; tested subtracting the 'ones' value).

;Now fix up the signs of the quotient (R0) and remainder (R1)
    POP    {R2, R3}                        ; Get dividend/divisor signs back
    EOR    R3, R2                            ; Result sign
    EOR    R0, R3                            ; Negate if result sign = -1
    SUB    R0, R3
    EOR    R1, R2                            ; Negate remainder if dividend sign = -1
    SUB    R1, R2
    MOV    pc, lr

```

3.39.2.2 ARM Code

```

signed_divide                                ; Effectively zero a4 as top bit will be shifted out later
        ANDS    a4, a1, #&80000000
        RSBMI   a1, a1, #0
        EORS    ip, a4, a2, ASR #32
;ip bit 31 = sign of result
;ip bit 30 = sign of a2
        RSBCS   a2, a2, #0

;Central part is identical code to udiv (without MOV a4, #0 which comes for free as part of signed entry sequence)
        MOVS    a3, a1
        BEQ     divide_by_zero

just_l                                       ; Justification stage shifts 1 bit at a time
        CMP     a3, a2, LSR #1
        MOVLS   a3, a3, LSL #1              ; NB: LSL #1 is always OK if LS succeeds
        BLO     s_loop

div_l
        CMP     a2, a3
        ADC     a4, a4, a4
        SUBCS   a2, a2, a3
        TEQ     a3, a1
        MOVNE   a3, a3, LSR #1
        BNE     s_loop2
        MOV     a1, a4
        MOVS    ip, ip, ASL #1
        RSBCS   a1, a1, #0
        RSBMI   a2, a2, #0
        MOV     pc, lr

```

3.39.3 DIVISION BY A CONSTANT

Division by a constant can often be performed by a short fixed sequence of shifts, adds and subtracts.

Here is an example of a divide by 10 routine based on the algorithm in the ARM Cookbook in both Thumb and ARM code.

3.39.3.1 Thumb Code

```

udiv10                                ; Take argument in a1 returns quotient in a1,
                                        ; remainder in a2
    MOV     a2, a1
    LSR     a3, a1, #2
    SUB     a1, a3
    LSR     a3, a1, #4
    ADD     a1, a3
    LSR     a3, a1, #8
    ADD     a1, a3
    LSR     a3, a1, #16
    ADD     a1, a3
    LSR     a1, #3
    ASL     a3, a1, #2
    ADD     a3, a1
    ASL     a3, #1
    SUB     a2, a3
    CMP     a2, #10
    BLT     %FT0
    ADD     a1, #1
    SUB     a2, #10
0
    MOV     pc, lr

```

3.39.3.2 ARM Code

```

udiv10                                ; Take argument in a1 returns quotient in a1,
                                        ; remainder in a2
    SUB     a2, a1, #10
    SUB     a1, a1, a1, lsr #2
    ADD     a1, a1, a1, lsr #4
    ADD     a1, a1, a1, lsr #8
    ADD     a1, a1, a1, lsr #16
    MOV     a1, a1, lsr #3
    ADD     a3, a1, a1, asl #2
    SUBS    a2, a2, a3, asl #1
    ADDPL   a1, a1, #1
    ADDMI   a2, a2, #10
    MOV     pc, lr

```

4 SYSTEM CONFIGURATION

4.1 OVERVIEW

The System Configuration consists of several functions that control the clock configuration, system bus arbitration method and address remap function etc.

4.2 FEATURES

Key features of the system configuration include the following;

- Various clock mode operation - the fastbus mode, sync mode and async mode
- Product code and revision number
- System clock control / clock status
- Peripheral clock enable/ disable
- AHB bus master priority define (Fixed / Round-Robin)
- Core, System, PHY PLL Configuration Register Setting.

4.3 ADDRESS MAP

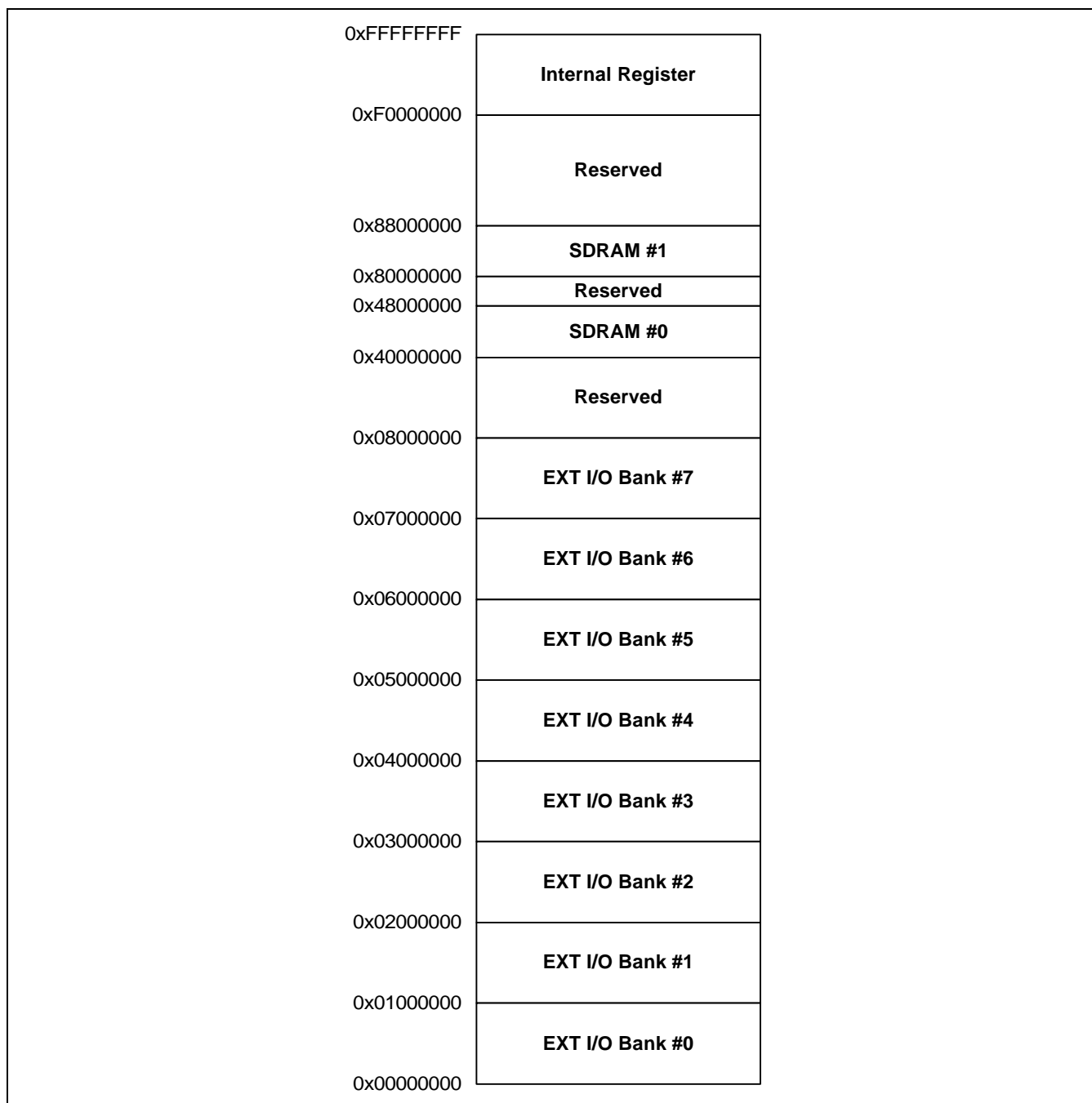

Figure 4-1. S3C2501X Address map after reset

Each memory block is mapped within the fixed location of memory space. As shown in the figure 4-1, the maximum size of ROM/SRAM/Flash/External IO bank is restricted to 16M-bytes and the SDRAM bank can be mapped within 1G-byte memory space. It must be noticed that the base address of each bank is fixed and the bank size is variable. Although the SDRAM bank size are up to 1G-bytes in the figure 4-1, the possible maximum size is 128M-bytes because the SDRAM controller can supports 256M-bit SDRAM component.

4.4 REMAP OF MEMORY SPACE

The S3C2501X supports the address remap function. When the remap function is enabled, the base address of each memory bank is changed as follows :

Table 4-1. The Base Address of Remapped Memory

	Before remap	After remap
Memory bank0	0x00000000	0x80000000
Memory bank1	0x01000000	0x81000000
Memory bank2	0x02000000	0x82000000
Memory bank3	0x03000000	0x83000000
Memory bank4	0x04000000	0x84000000
Memory bank5	0x05000000	0x85000000
Memory bank6	0x06000000	0x86000000
Memory bank7	0x07000000	0x87000000
SDRAM bank0	0x40000000	0x00000000
SDRAM bank1	0x80000000	0x40000000

4.5 EXTERNAL ADDRESS TRANSLATION

The S3C2501X address bus is , in some respects, different than the bus used in other standard CPUs. Based on the required data bus width of each memory bank, the internal system address bus is shifted out to an external address bus, ADDR[23:0].

Data Bus Width	External Address Pins, ADDR[23:0]	Accessible Memory Size
8-bit	A23-A0 (internal)	16M-bytes
16-bit	A24-A1 (internal)	8M-half-words
32-bit	A25-A2 (internal)	4M-words

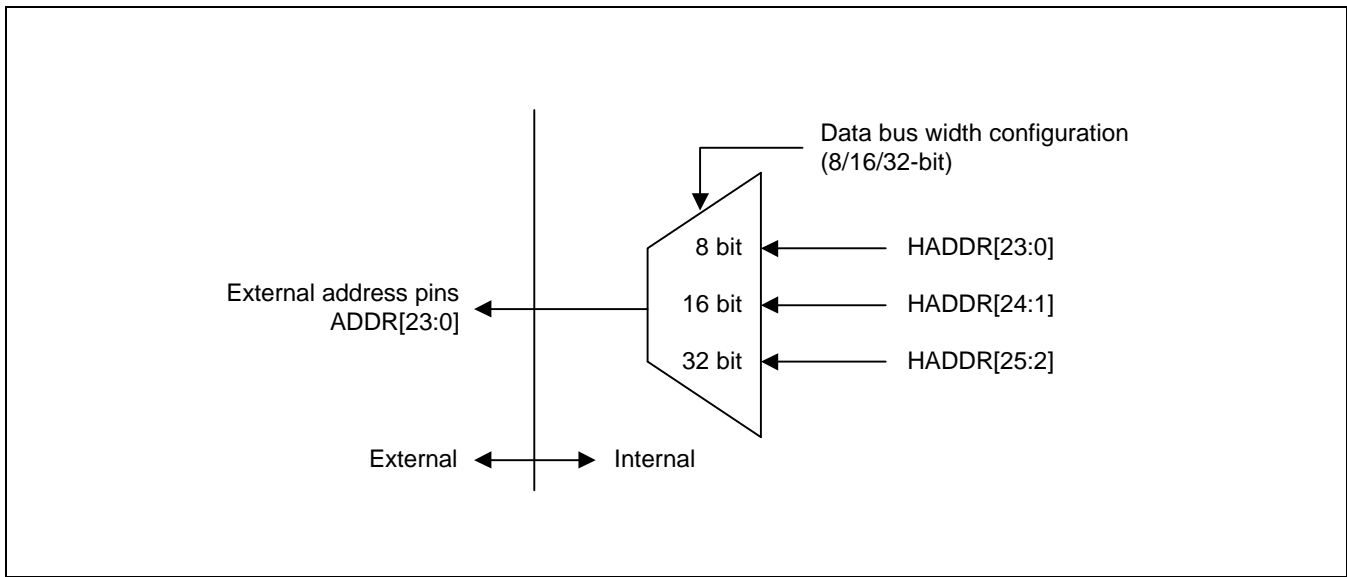

Figure 4-2. External Address Bus Diagram

4.6 ARBITRATION SCHEME

The S3C2501X can support the fixed priority and the round-robin method for AHB bus arbitration by register setting. Especially, the S3C2501X can program the priority order in the fixed priority mode as well as the ratio of the bus occupancy in the round-robin priority mode.

The internal function blocks or AHB bus masters are divided into three groups, Group A, Group B, and Group C. Group A has only Test Interface Controller (TIC) block. The Group A has the highest bus priority. Group B has 3 AHB bus masters, General DMA, Ethernet Controller 0, Ethernet Controller 1. The S3C2501X can program the bus priority of each bus masters among Group B. So the bus priority of bus masters in only Group B can be programmed. Group C has the ARM940T CPU. The relative priority of Group B and Group C is determined more or less in an alternating manner.

The local priority of six channels of general DMA can be programmed by fixed priority or round-robin priority in similar manner to the AHB bus priority. Please refer to the general DMA chapter.

Table 4-2. AHB Bus Priorities for Arbitration

Function Block	AHB Bus Priority (Group)
Test Interface Controller (TIC)	Group A (highest priority)
General DMA (GDMA)	Group B
Ethernet Controller 0	Group B
Ethernet Controller 1	Group B
ARM940T CPU	Group C

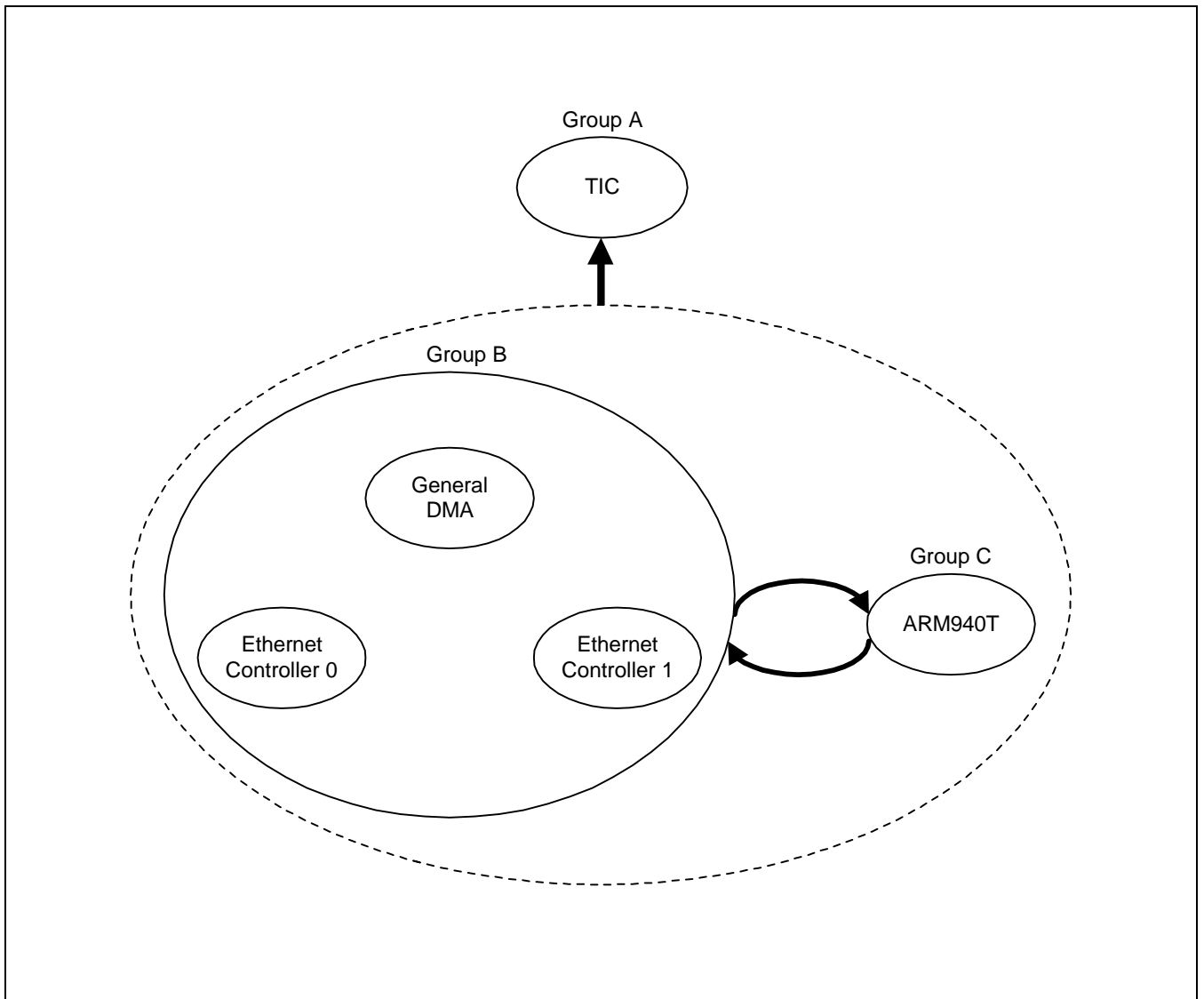

Figure 4-3. Priority Groups of S3C2501X

AHB Bus Programmable Priority Registers are HPRIF(Programmable Priority Register for Fixed) and HPRIR (Programmable Priority Register for Round-Robin).

If system configuration register (0xF0000000) SYSCFG[0] = 0x1, the programmable fixed priority is run by HPRIF register. Each master has its own fixed priority index. For example, GDMA has the index 0. The index for each master is shown in Figure 4-4. The reset value of HPRIF register is 0x00543210. The first field of HPRIF[3:0] indicates the highest priority and the HPRIF[7:4] indicates the second highest priority and so on. HPRIF[23:12] should not be writtern any value and must always be 0x543.

The users are allowed to program HPRIF[11:0]. When the SYSCFG[0] = 0x1 and the HPRIF is 0x00543012, the fixed priority order form the highest to the lowest is Ethernet controller1, ethernet controller0 and General DMA.

If system configuration register (0xF0000000) SYSCFG[0] = 0x0, the programmable round-robin priority is run by HPRIR register. All AHB bus masters own their respective field position in HPRIR. The ratio of the bus occupancy can be programmed by writing an arbitrary value on each field. The arbitrary value can be 0x0 to 0xF. The reset value of HPRIR register is 0x00000000. The position for each master is shown in Figure 4-4. The ratio of the bus occupancy of the bus master in the first field is intended to be $(hprir0+1)/((hprir2+1)+(hprir1+1)+(hprir0+1)+3)$ and so on. However, the arbiter of S3C2501X has a fairness problem.

The HPRIR should be programmed by the value of 0x000330 to have the same occupancy ratio for three masters.

The arbiter has a problem that the GDMA always has three more chances to occupy the bus than other masters. Therefore, hprir2 and hprir1 should have the value of (hprir0+3) to keep the same occupancy ratio.

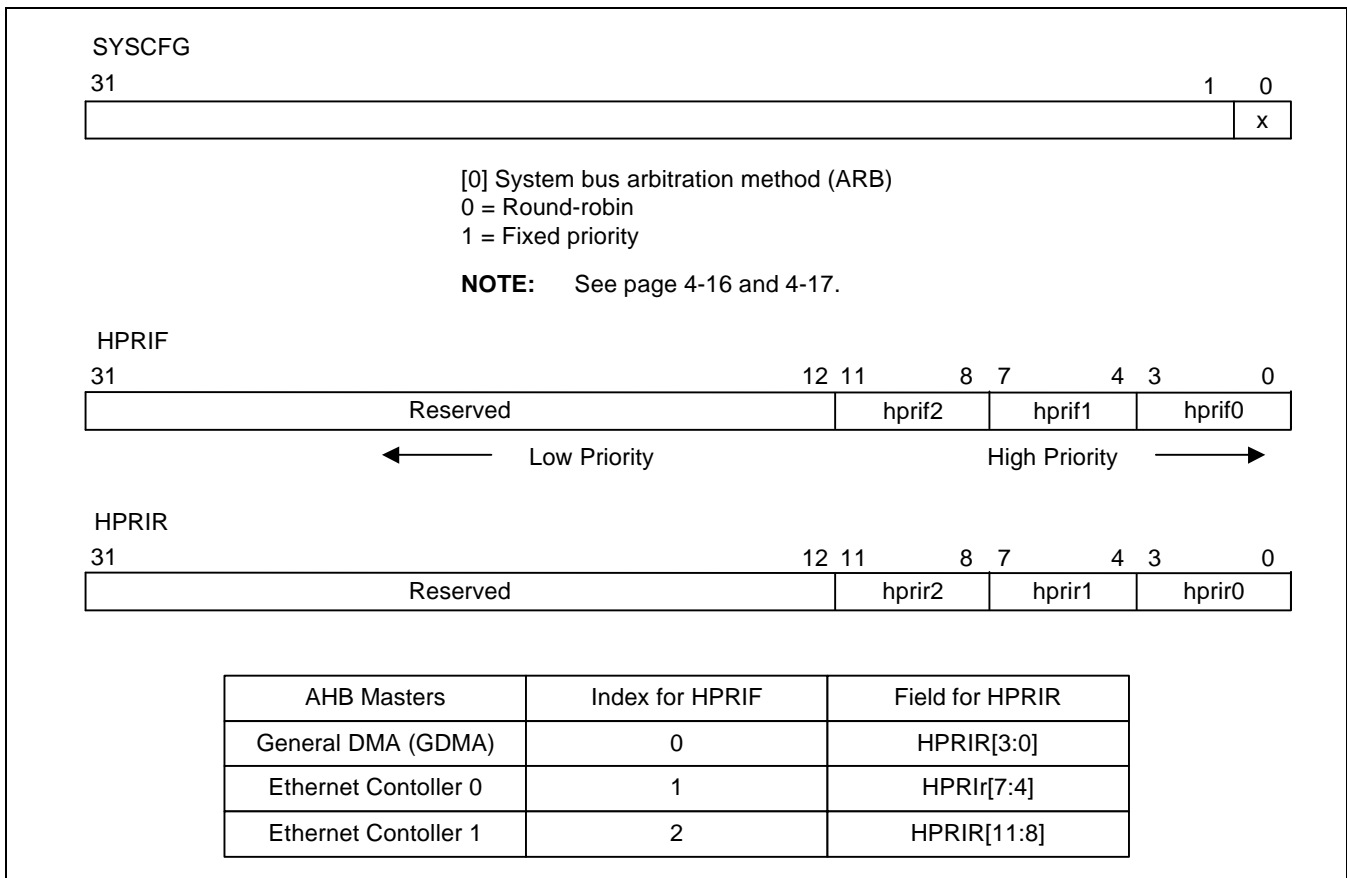

Figure 4-4. AHB Programmable Priority Registers

4.6.1 PROBLEM SOLVINGS WITH PROGRAMMABLE ROUND-ROBIN

S3C2501X has a stuff to think about with arbiter operation. This only applies to arbiter with Round-Robin priority. Assuming all '0's are set for HPRIR register for Round-Robin, HPRIR (all same bus occupancy in Round-Robin), and only three of six masters are used, the problem arises as follows.

Number	HPRIR	Channel	Expected Bus Occupancy	Actual Running Block	Real System Bus Occupancy
1	0	GDMA	1/3	GDMA	1/6
2	0	Ethernet Controller 0	1/3	Ethernet Controller 0	1/6
3	0	Ethernet Controller 1	1/3	Ethernet Controller 1	1/6
4	0	Reserved Master 0	0	GDMA	1/6
5	0	Reserved Master 1	0	GDMA	1/6
6	0	Reserved Master 2	0	GDMA	1/6

When HPRIR is 0x0 and only GDMA , Ethernet controller 0 and 1 are used, the expected bus occupancy for each channel is 1/3. However, S3C2501X does not work that way, instead, GDMA gets 4/6 of the bus occupancy, Ethernet controller 0 1/6, and Ethernet controller 1 1/6. In short, GDMA is run four times more than Ethernet controller 0 and 1. This is because S3C2501X is designed to turn the bus occupancy to the next master when there is non-used master. For instance,

Number 1: GDMA

Number 2: Ethernet controller 0

Number 3: Ethernet controller 1

Number 4: Reserved Master 0 → go to number 5: Reserved Master 1 → go to number 6: Reserved Master 2 → go to number 1: GDMA

Number 5: Reserved Master 1 → go to number 6: Reserved Master 2 → go to number 1: GDMA

Number 6: Reserved Master 2 → go to number 1: GDMA

The following is the problem solving with software.

HPRIR	Channel	Expected Bus Occupancy	Real System Bus Occupancy
0	GDMA	1/3	4/6
0	Ethernet controller 0	1/3	1/6
0	Ethernet controller 1	1/3	1/6
0		0	0
0		0	0
0		0	0

Problem

⇒

HPRIR	Channel	Occupancy
0	GDMA	1/3
3	Ethernet controller 0	1/3
3	Ethernet controller 1	1/3
0		0
0		0
0		0

Problem Solving

Writing "0x000330", instead of "0x0" will give each channel of three masters with the same amount of bus occupancy. This is because GDMA is run to fill the blank of reserved masters.

4.7 CLOCK CONFIGURATION

The S3C2501X has three PLL clocking scheme – CPU PLL, System BUS PLL, PHY PLL. All of the PLL can operate if the corresponding clock select pin is set to “0” (CLKSEL- shared with CPU PLL and System BUS PLL, PHY_CLKSEL). When the clock select pin is set to “1”, the PLL goes into power down state. The CPU PLL can generate ARM940T clock or system bus clock depending on clock mode selection (CLKMOD[1:0]). The System BUS PLL generates system bus clock only. The PHY PLL generates clock for external devices. Each PLL clock output frequency can be programmed by either the pin setting or software setting. In pin configurable mode, the CPU_FREQ[2:0] pins determine the frequency of the CPU PLL clock output and the BUS_FREQ[2:0] pins determine the frequency of the System BUS PLL clock output. The PHY_FREQ pin determines the frequency of the PHY PLL output. The PHY PLL generates 2 times the input clock if the PHY_FREQ is “0” and 2.5 times the input clock if the PHY_FREQ is “1”.

The CLKMOD[1:0] pins determine the relation of the ARM940T clock and the system clock. If the CLKMOD[1:0] is “00”, the fastbus clock mode is defined. In this mode, the ARM940T clock and the system bus clock is the same clock and the clock is from the CPU PLL output. The two clocks are of the same phase and of the same frequency. If the CLKMOD[1:0] is “10” or “01”, the sync clock mode is defined. In this mode, the frequency of the ARM940T clock is always 2 times that of the system bus clock. If the CLKMOD[1:0] is “11”, the async clock mode is defined. In this mode, the ARM940T clock is out of the CPU PLL and the system bus clock is out of the System BUS PLL. The frequency of the two clocks could be set to any frequency so long as the the frequency of the ARM940T clock is faster than that of the system bus clock. The table 4-3 shows the clock configuration of the external pin setting.

Table 4-3. Clock Frequencies for CLKMOD Pins, CPU_FREQ Pins, and BUS_FREQ Pins

CLKMOD [1:0]	CPU_FREQ [2:0]	BUS_FREQ [2:0]	ARM940T Clock Frequency	AMBA BUS Clock Frequency
2'b00 (Fastbus)	3'b000	3'bxxx	166MHz	166MHz
	3'b001	3'bxxx	150MHz	150MHz
	3'b010	3'bxxx	133MHz	133MHz
	3'b011	3'bxxx	125MHz	125MHz
	3'b100	3'bxxx	100MHz	100MHz
	3'b101	3'bxxx	66MHz	166MHz
	3'b110	3'bxxx	50MHz	50MHz
	3'b111	3'bxxx	33MHz	33MHz
2'b10 (Sync1)	3'b000	3'bxxx	166MHz	83MHz
	3'b001	3'bxxx	150MHz	75MHz
	3'b010	3'bxxx	133MHz	66MHz
	3'b011	3'bxxx	125MHz	62.5MHz
	3'b100	3'bxxx	100MHz	50MHz
	3'b101	3'bxxx	66MHz	33MHz
	3'b110	3'bxxx	50MHz	25MHz
	3'b111	3'bxxx	33MHz	25MHz

Table 4-3. Clock Frequencies for CLKMOD Pins, CPU_FREQ Pins, and BUS_FREQ Pins (Continued)

CLKMOD [1:0]	CPU_FREQ [2:0]	BUS_FREQ [2:0]	ARM940T Clock Frequency	AMBA BUS Clock Frequency
2'b10 (Sync1)	3'b111	3'bxxx	33MHz	16.5MHz
2'b01 (Sync0)	3'b000	3'bxxx	300MHz	150MHz
	3'b001	3'bxxx	266MHz	133MHz
	3'b010	3'bxxx	233MHz	116.5MHz
	3'b011	3'bxxx	200MHz	100MHz
	3'b100	3'bxxx	166MHz	83MHz
	3'b101	3'bxxx	166MHz	83MHz
	3'b110	3'bxxx	166MHz	83MHz
	3'b111	3'bxxx	166MHz	83MHz
2'b11 (Async)	3'b000	3'b000	166MHz	133MHz
	3'b000	3'b001	166MHz	133MHz
	3'b000	3'b010	166MHz	133MHz
	3'b000	3'b011	166MHz	125MHz
	3'b000	3'b100	166MHz	100MHz
	3'b000	3'b101	166MHz	66MHz
	3'b000	3'b110	166MHz	50MHz
	3'b000	3'b111	166MHz	33MHz
2'b11 (Async)	3'b001	3'b000	150MHz	133MHz
	3'b001	3'b001	150MHz	133MHz
	3'b001	3'b010	150MHz	133MHz
	3'b001	3'b011	150MHz	125MHz
	3'b001	3'b100	150MHz	100MHz
	3'b001	3'b101	150MHz	66MHz
	3'b001	3'b110	150MHz	50MHz
	3'b001	3'b111	150MHz	33MHz
Not supported				

Table 4-3. Clock Frequencies for CLKMOD Pins, CPU_FREQ Pins, and BUS_FREQ Pins (Continued)

CLKMOD [1:0]	CPU_FREQ [2:0]	BUS_FREQ [2:0]	ARM940T Clock Frequency	AMBA BUS Clock Frequency
2'b11(Async)	3'b010	3'b000	133MHz	133MHz
	3'b010	3'b001	133MHz	133MHz
	3'b010	3'b010	133MHz	133MHz
	3'b010	3'b011	133MHz	125MHz
	3'b010	3'b100	133MHz	100MHz
	3'b010	3'b101	133MHz	66MHz
	3'b010	3'b110	133MHz	50MHz
	3'b010	3'b111	133MHz	33MHz
2'b11 (Async)	3'b011	3'b000	125MHz	133MHz
	3'b011	3'b001	125MHz	133MHz
	3'b011	3'b010	125MHz	133MHz
	3'b011	3'b011	125MHz	125MHz
	3'b011	3'b100	125MHz	100MHz
	3'b011	3'b101	125MHz	66MHz
	3'b011	3'b110	125MHz	50MHz
	3'b011	3'b111	125MHz	33MHz
2'b11 (Async)	3'b100	3'b000	100MHz	133MHz
	3'b100	3'b001	100MHz	133MHz
	3'b100	3'b010	100MHz	133MHz
	3'b100	3'b011	100MHz	125MHz
	3'b100	3'b100	100MHz	100MHz
	3'b100	3'b101	100MHz	66MHz
	3'b100	3'b110	100MHz	50MHz
	3'b100	3'b111	100MHz	33MHz
2'b11 (Async)	3'b101	3'b000	66MHz	133MHz
	3'b101	3'b001	66MHz	133MHz
	3'b101	3'b010	66MHz	133MHz
	3'b101	3'b011	66MHz	125MHz
	3'b101	3'b100	66MHz	100MHz
	3'b101	3'b101	66MHz	66MHz
	3'b101	3'b110	66MHz	50MHz
	3'b101	3'b111	66MHz	33MHz
Not supported				

Table 4-3. Clock Frequencies for CLKMOD Pins, CPU_FREQ Pins, and BUS_FREQ Pins (Continued)

CLKMOD [1:0]	CPU_FREQ [2:0]	BUS_FREQ [2:0]	ARM940T Clock Frequency	AMBA BUS Clock Frequency
2'b11 (Async)	3'b110	3'b000	50MHz	133MHz
	3'b110	3'b001	50MHz	133MHz
	3'b110	3'b010	50MHz	133MHz
	3'b110	3'b011	50MHz	125MHz
	3'b110	3'b100	50MHz	100MHz
	3'b110	3'b101	50MHz	66MHz
	3'b110	3'b110	50MHz	50MHz
	3'b110	3'b111	50MHz	33MHz
Not supported				

Each PLL can also be programmed by S/W register setting. Each PLL is in pin configurable mode after the system reset is released. You can change the PLL configuration mode to the register configurable mode by set CPLLREN, SPLLEN, PLLREN in the SYSCFG[31:28]. If the PLL register enable bit is set to "1", the PLL multiplication factor is not from the external pin but from the corresponding PLLCON register-CPLLCON, SPLLCON, PLLCON registers. The PLL is controlled by the 3 control variables, P, M, S. When the PLL is under the control of the S/W and the PLL control variables are dynamically changed by the S/W, the glitch may occur in the PLL output clock. You can avoid the glitch generation by set the PLL clock enable bit, CPLLCE, SPLLCE, PLLCE in the SYSCFG [27:24]. When the PLL clock enable bit is set to "0" during the PLL control variable change, the stable PLL output clock is provided. The PLL output frequency is determined as follows.

$$F_{out} = F_{in} \times (M+8) / ((P+2) \times (2^S))$$

Where the F_{in} is the frequency of the PLL input clock and the F_{out} is the frequency of the PLL output clock.

The four PLLs in the S3C2501X are controlled by above formula and the table 4-4 shows the PLL variables for the most widely used frequencies.

Table 4-4. P, M, S values of the S3C2501X PLL

P[5:0]	M[7:0]	S[1:0]	PLL Input Clock Frequency	PLL Output Clock Frequency
00_0001	0101_0010	00	10MHz	300MHz
00_0001	0100_1000	00	10MHz	266MHz
00_0001	1000_0100	01	10MHz	233MHz
00_0001	0111_0000	01	10MHz	200MHz
00_0011	1001_1110	01	10MHz	166MHz
00_0001	0101_0010	01	10MHz	150MHz
00_0001	0100_1000	01	10MHz	133MHz
00_0001	0100_0011	01	10MHz	125MHz
00_0001	0111_0000	10	10MHz	100MHz
00_0011	1011_1000	10	10MHz	96MHz
00_0001	0100_1000	10	10MHz	66MHz
00_0001	0111_0000	11	10MHz	50MHz
00_0011	1011_1000	11	10MHz	48MHz
00_0001	0100_1000	11	10MHz	33MHz

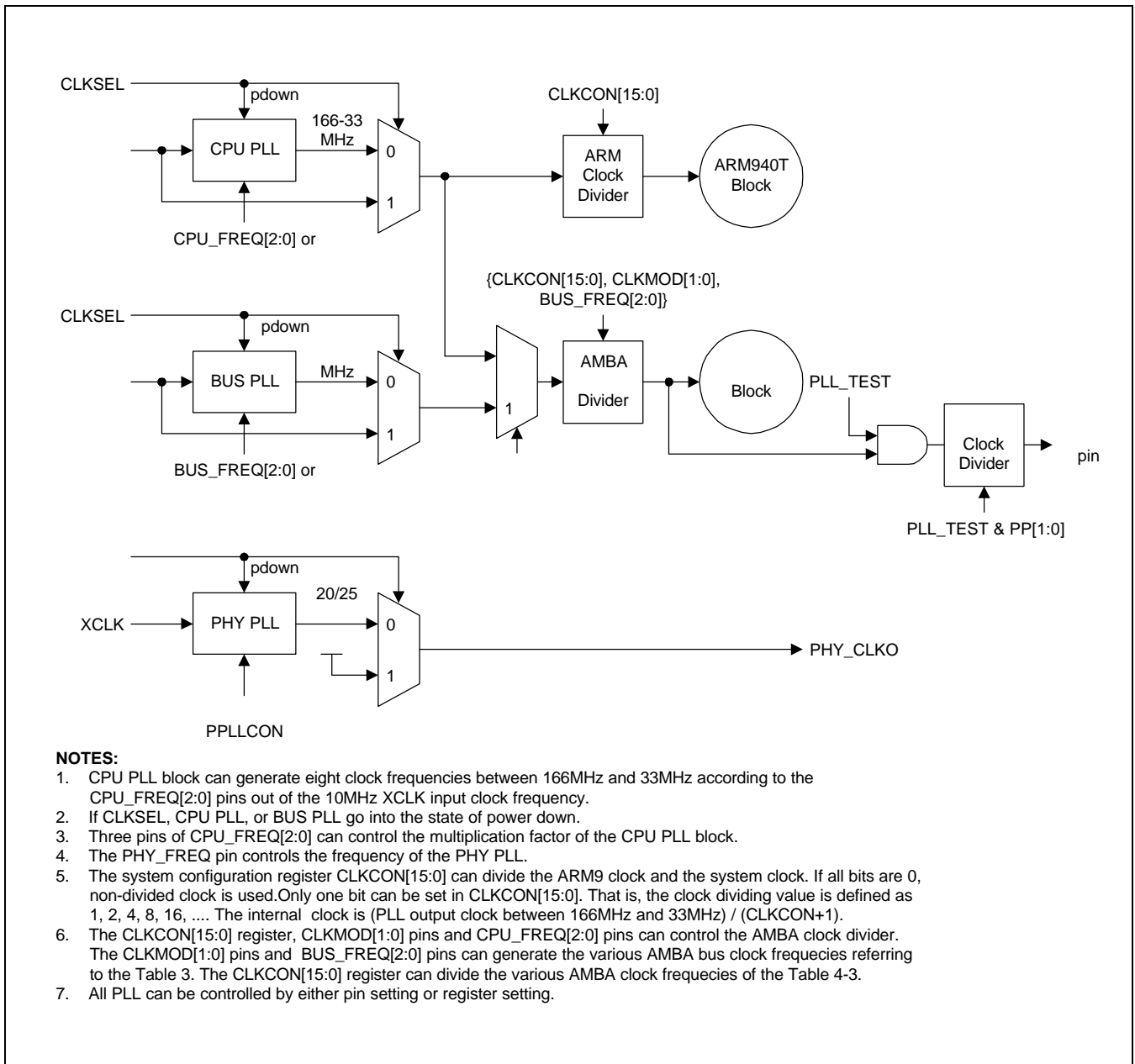

Figure 4-5. Shows the Clock Generation Logic of the S3C2501X

4.8 SYSTEM CONFIGURATION SPECIAL REGISTERS

The System Configuration registers are as follows.

Table 4-5. System Configuration Registers

Name	Address	Description	Reset Value
SYSCFG	0xF0000000	System configuration register	–
PDCODE	0xF0000004	Product code and revision number register	0x25010000
CLKCON	0xF0000008	System clock control register	0x00000000
PCLKDIS	0xF000000C	Peripheral clock disable register	0x0F000500
CLKST	0xF0000010	Clock Status register	
HPRIF	0xF0000014	AHB bus master fixed priority register	0x00543210
HPRIR	0xF0000018	AHB bus master round-robin priority register	0x00000000
CPLLCON	0xF000001C	Core PLL Configuration Register	0x0001039E
SPLLCON	0xF0000020	System BUS PLL Configuration Register	0x00010370
PPLLCON	0xF0000028	PHY PLL Configuration Register	0x00010311

4.8.1 SYSTEM CONFIGURATION REGISTER (SYSCFG)

You can control the system bus arbitration method, PLL operation, system clock output enable/disable function, external memory address remap function and Little/Big information read function by SYSCFG.

Register	Address	R/W	Description	Reset Value
SYSCFG	0xF0000000	R/W	System configuration register	–

SYSCFG	Bit	Description	Initial State
CPLLREN	[31]	CPLLCON Register Enable This bit controls which value is used for the CPU PLL constant from the two constant values. When this bit is set to “0”, the CPU PLL constant is from CPU_FREQ[2:0] setting. When this bit is set to “1”, the CPU PLL constant is from the CPLLCON register.	0
SPLLREN	[30]	SPLLCON Register Enable This bit controls which value is used for the BUS PLL constant from the two constant values. When this bit is set to “0”, the BUS PLL constant is from BUS_FREQ[2:0] setting. When this bit is set to “1”, the BUS PLL constant is from the SPLLCON register.	0
PPLLREN	[28]	PPLLCON Register Enable This bit controls which value is used for the PHY PLL constant from the two constant values. When this bit is set to “0”, the PHY PLL constant is from PHY_FREQ setting. When this bit is set to “1”, the PHY PLL constant is from the PPLLCON register.	0
CPLLFD	[27]	CPLL Filter Disable This bit determines whether the CPU PLL output is filtered or not during the configuration. When this bit is set to “0”, the CPU PLL output is filtered to be provided to the system during the configuration. In this case, the glitch output from PLL can be masked. When this bit is set to “1”, the CPU PLL output is not filtered to be provided to the system.	0
SPLLFD	[26]	SPLL Filter Disable This bit determines whether the BUS PLL output is filtered or not during the configuration. When this bit is set to “0”, the BUS PLL output is filtered to be provided to the system during the configuration. In this case, the glitch output from PLL can be masked. When this bit is set to “1”, the BUS PLL output is not filtered to be provided to the system.	0

SYSCFG	Bit	Description	Initial State
PPLIFD	[24]	PPLL Filter Disable This bit determines whether the PHY PLL output is filtered or not during the configuration. When this bit is set to "0", the PHY PLL output is filtered to be provided to the PHY during the configuration. In this case, the glitch output from PLL can be masked. When this bit is set to "1", the PHY PLL output is not filtered to be provided to the PHY.	0
BIG	[16]	Little / Big endian information (Read only) 0 = Little endian 1 = Big endian	–
REMAP	[8]	External memory address remapping enable 0 = Remap disable 1 = Remap Enable ROM Bank0 : 0x00000000 ROM Bank0 : 0x80000000 ROM Bank1 : 0x01000000 ROM Bank1 : 0x81000000 ROM Bank2 : 0x02000000 ROM Bank2 : 0x82000000 ROM Bank3 : 0x03000000 ROM Bank3 : 0x83000000 ROM Bank4 : 0x04000000 ROM Bank4 : 0x84000000 ROM Bank5 : 0x05000000 ROM Bank5 : 0x85000000 ROM Bank6 : 0x06000000 ROM Bank6 : 0x86000000 ROM Bank7 : 0x07000000 ROM Bank7 : 0x87000000 SDRAM Bank0 : 0x40000000 SDRAM0 bank0 : 0x00000000 SDRAM Bank1 : 0x80000000 SDRAM1 bank1 : 0x40000000	0
HCLKO_DIS	[4]	HCLKO output disable If this bit is set to "1", HCLKO output is activated only when sdram access - sdram read/write or refresh - is enabled. If this bit is set to "0", HCLKO is always activated. 0 = Enabled always 1 = Enabled during sdram access.	0
ARB	[0]	System bus arbitration method 0 = Round-robin 1 = Fixed priority	0

4.8.2 PRODUCT CODE AND REVISION NUMBER REGISTER (PDCODE)

Register	Address	R/W	Description	Reset Value
PDCODE	0xF0000004	R	Product code and revision number register	0x25010000

PDCODE	Bit	Description	Initial State
PC	[31-16]	Product code	0x2501
Reserved	[15:8]	Reserved	0x0
MajRev	[7:4]	Major revision number	0x0
MinRev	[3:0]	Minor revision number	0x0

4.8.3 CLOCK CONTROL REGISTER (CLKCON)

There is clock control register(CLKCON) in system configuration. For the purpose of power save, Clock control register(CLKCON) can be programmed at low frequency and the slower clock than the system clock can be made by clock dividing value. When the internal system clock is divided by CLKCON, its duty-cycle is changed. If CLKCON is programmed to zero, the internal system clock remains the same as the internal clock. In other case, the duty cycle of internal system clock is no longer 50%.

Register	Address	R/W	Description	Reset Value
CLKCON	0xF0000008	R/W	Clock control register	0x00000000

CLKCON	Bit	Description	Initial State
Reserved	[31:16]	Reserved	0
DVAL	[15:0]	System clock dividing value. If all bits are 0, non-divided clock is used. Only one bit can be set in CLKCON[15:0]. That is, the clock dividing value is defined as 1, 2, 4, 8, 16, ... Internal system clock is (PLL output clock) / (CLKCON+1).	0

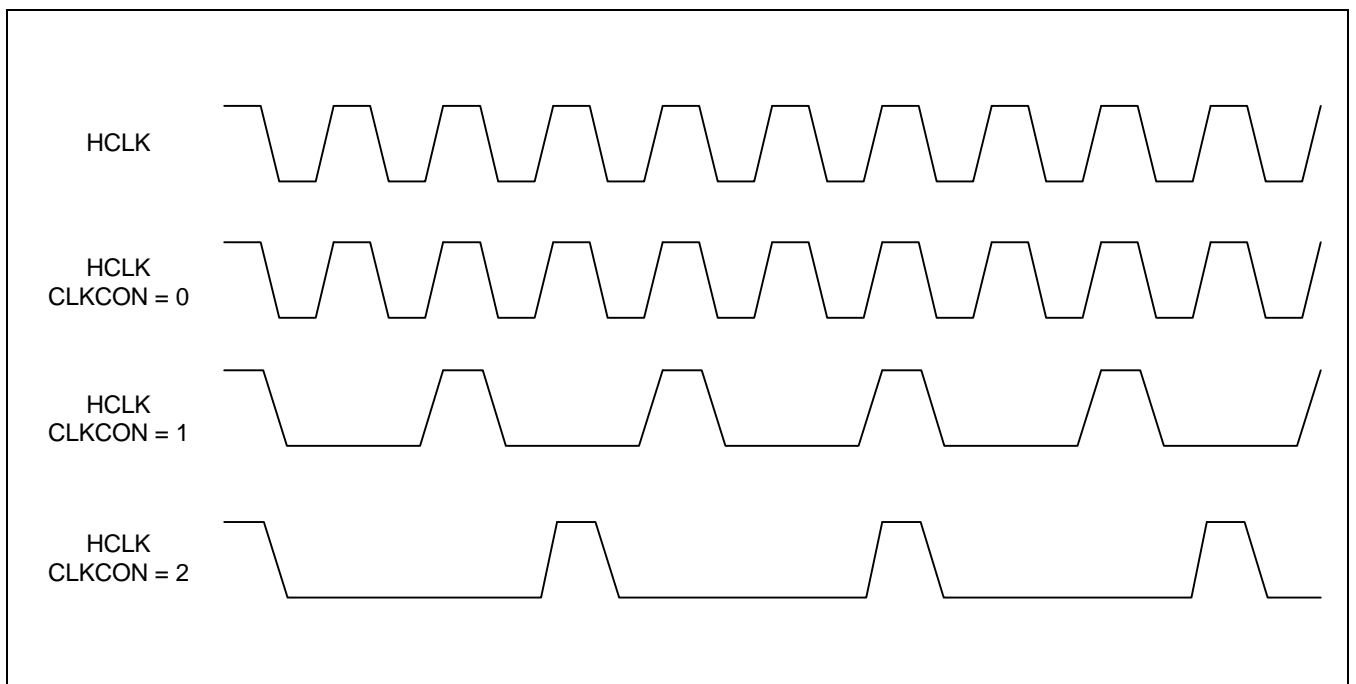

Figure 4-6. Divided System Clock Timing Diagram

4.8.4 PERIPHERAL CLOCK DISABLE REGISTER (PCLKDIS)

There is a peripheral clock disable register in system configuration. You can set this register with the specific value for the purpose of power save. If you set PCLKDIS[0] to "1", the clock for GDMA channel 0 is disabled. Similarly, you control the clock input of each peripheral.

Register	Address	R/W	Description	Reset Value
PCLKDIS	0xF000000C	R/W	Peripheral clock disable register	0x0F000500

PCLKDIS	Bit	Description	Initial State
SRreq	[31]	SDRAM Self-refresh request	0x0
SRack	[30]	SDRAM Self-refresh acknowledge (Read only)	0x0
Reserved	[29:28]	Reserved for future use	0x0
Reserved	[27]	Reserved	1
Reserved	[26]	Reserved	1
Reserved	[25]	Reserved	1
Reserved	[24]	Reserved	1
SDRAMC	[23]	SDRAMC clock disable	0x0
MEMCON	[22]	MEMCON clock disable	0x0
DES	[21]	DES clock disable	0x0
IIC	[20]	IIC Clock disable	0x0
IOPC	[19]	IOPC clock disable	0x0
WDT	[18]	Watch dog timer clock disable	0x0
TIMER5	[17]	TIMER5 clock disable	0x0
TIMER4	[16]	TIMER4 clock disable	0x0
TIMER3	[15]	TIMER3 clock disable	0x0
TIMER2	[14]	TIMER2 clock disable	0x0
TIMER1	[13]	TIMER1 clock disable	0x0
TIMER0	[12]	TIMER0 clock disable	0x0
HUART	[11]	HUART clock disable	0x0
Reserved	[10]	Reserved	1
CUART	[9]	CUART clock disable	0x0
Reserved	[8]	Reserved	1
ETHERC1	[7]	ETHERC1 clock disable	0x0
ETHERC0	[6]	ETHERC0 clock disable	0x0
GDMA5	[5]	GDMA channel 5 clock disable	0x0
GDMA4	[4]	GDMA channel 4 clock disable	0x0
GDMA3	[3]	GDMA channel 3 clock disable	0x0
GDMA2	[2]	GDMA channel 2 clock disable	0x0
GDMA1	[1]	GDMA channel 1 clock disable	0x0
GDMA0	[0]	GDMA channel 0 clock disable	0x0

4.8.5 CLOCK STATUS REGISTER (CLKST)

The operating frequency of the S3C2501X can be obtained by reading the CLKST register. The CPU Freq field in CLKST[11:0] decodes the CPU_FREQ[2:0] settings and the BUS Freq in CLKST[23:12] decodes the BUS_FREQ[2:0] settings. There are 3 clock modes in the S3C2501X - fast mode, sync mode and async mode. In async mode, there is no misinformation about the frequency. But Care must be taken for the fastbus mode and sync mode. In the fastbus mode, the BUS frequency in the CLKST[23:12] should be ignored and the CPU frequency in the CLKST[11:0] should be taken for the BUS frequency because the CPU clock and system bus clock is the same. In the sync mode, the BUS frequency in the CLKST[23:12] should also be ignored, and the half of the CPU frequency should be taken for the BUS frequency.

Register	Address	R/W	Description	Reset Value
CLKST	0xF0000010	R	Clock Status register (Read Only)	–

CLKST	Bit	Description	Initial State
Clock Mode	[31:30]	00 = FastBus mode 10 = Reserved 01 = Synchronous 11 = Asynchronous	
Reserved	[29:24]		
BUS Freq	[23:12]	System Bus Clock frequency	
CPU Freq	[11:0]	CPU Clock frequency	

4.8.6 AHB BUS MASTER PRIORITY REGISTER

Register	Address	R/W	Description	Reset Value
HPRIF	0xF0000014	R/W	AHB bus master fixed priority register	0x00543210
HPRIR	0xF0000018	R/W	AHB bus master round-robin priority register	0x00000000

4.8.7 CORE PLL CONTROL REGISTER (CPLLCON)

If you want to use this register, you should set CPLLREN in SYSCFG[31] to "1". This register doesn't work with CPLLREN set to "0".

Register	Address	R/W	Description	Reset Value
CPLLCON	0xF000001C	R/W	Core PLL control register	0x0001039E

CPLLCON	Bit	Description	Initial State
Reserved	[31:12]		0x0
S	[17:16]	Scaler	0x1
Reserved	[15:14]		0x0
P	[13:8]	Pre divider	0x3
M	[7:0]	Main divider	0x9E

Output clock frequency is determined by following formula.

$$F_{out} = F_{in} \times (M+8) / ((P+2) \times (2^S))$$

If $F_{in} = 10\text{MHz}$, $P = 3$, $M = 158$ (0x9E), and $S = 1$, F_{out} is 166 MHz.

FCLK signal of ARM940T core is connected to F_{out} , 166MHz clock. But, BCLK signal of ARM940T and system bus clock is connect to $F_{out} / 2$, 66 MHz clock.

4.8.8 SYSTEM BUS PLL CONTROL REGISTER (SPLLCON)

If you want to use this register, you should set SPLLREN in SYSCFG[30] to "1". This register doesn't work with SPLLREN set to "0".

Register	Address	R/W	Description	Reset Value
SPLLCON	0xF0000020	R/W	System BUS PLL control register	0x0001037D

SPLLCON	Bit	Description	Initial State
Reserved	[31:12]		0x0
S	[17:16]	Scaler	0x1
Reserved	[15:14]		0x0
P	[13:8]	Pre divider	0x3
M	[7:0]	Main divider	0x7D

Output clock frequency is determined by following formula.

$$F_{out} = F_{in} \times (M+8) / ((P+2) \times (2^S))$$

If $F_{in} = 10\text{MHz}$, $P = 3$, $M = 125$ (0x7D), and $S = 1$, F_{out} is 133 MHz.

FCLK signal of ARM940T core is connected to F_{out} , 133MHz clock. But, BCLK signal of ARM940T and system bus clock is connect to $F_{out} / 2$, 66 MHz clock.

4.8.9 PHY PLL CONTROL REGISTER (PPLLCON)

If you want to use this register, you should set PPLLREN in SYSCFG[28] to "1". This register doesn't work with PPLLREN set to "0".

Register	Address	R/W	Description	Reset Value
PPLLCON	0xF0000028	R/W	PHY PLL control register	0x00010311

PPLLCON	Bit	Description	Initial State
Reserved	[31:12]		0x0
S	[17:16]	Scaler	0x1
Reserved	[15:14]		0x0
P	[13:8]	Pre divider	0x3
M	[7:0]	Main divider	0x11

Output clock frequency is determined by following formula.

$$F_{out} = F_{in} \times (M+8) / ((P+2) * (2^S))$$

If $F_{in} = 10\text{MHz}$, $P = 3$, $M = 17$ (0x11), and $S = 1$, F_{out} is 25MHz.

5

MEMORY CONTROLLER

5.1 OVERVIEW

This Memory controller consists of Ext I/O Bank controller and SDRAM controller. Ext I/O Bank controller supports ROM, SRAM and Flash memory. SDRAM controller support SDRAM.

The S3C2501X Memory controller has the following functions.

- To provide the required memory control signals for external memory accesses. For example, if a master block such as DMA controller or CPU generates an address that corresponds to a SDRAM bank, the SDRAM controller generates the required SDRAM access signals.
- To provide the required signals for bus traffic between the S3C2501X and ROM/SRAM and the external I/O banks.
- To compensate for differences in bus width for data flowing between the external memory bus and the internal data bus.
- S3C2501X supports both little and big endians for external memory or I/O devices.

5.2 FEATURES

The following is a list of the Memory Controller's features:

- 10 banks (8 banks for ROM / SRAM / Flash Memory / External I/O interface, 2 banks for SDRAM interface)
- 16M-byte maximum address range per bank (24 bit external address pins)
- 32 bit internal and external data bus
- Various timing control options

NOTE

By generating an external bus request, an external device can access the S3C2501X's external memory interface pins. In addition, the S3C2501X can access slow external devices by using a WAIT signal. The WAIT signal, which is generated by the external device, extends the duration of the CPU's memory access cycle beyond its programmable value.

5.3 MEMORY MAP

After a power-on or system reset, all bank address pointer registers are initialized to their default values. And the base address of all banks are fixed.

The initial system memory map following system start-up is shown in Figure 5-1.

Table 5-1. Base Address of Each Bank

Bank	Base Address
EXT I/O Bank 0	0x00000000
EXT I/O Bank 1	0x01000000
EXT I/O Bank 2	0x02000000
EXT I/O Bank 3	0x03000000
EXT I/O Bank 4	0x04000000
EXT I/O Bank 5	0x05000000
EXT I/O Bank 6	0x06000000
EXT I/O Bank 7	0x07000000
SDRAM Bank 0	0x40000000
SDRAM Bank 1	0x80000000

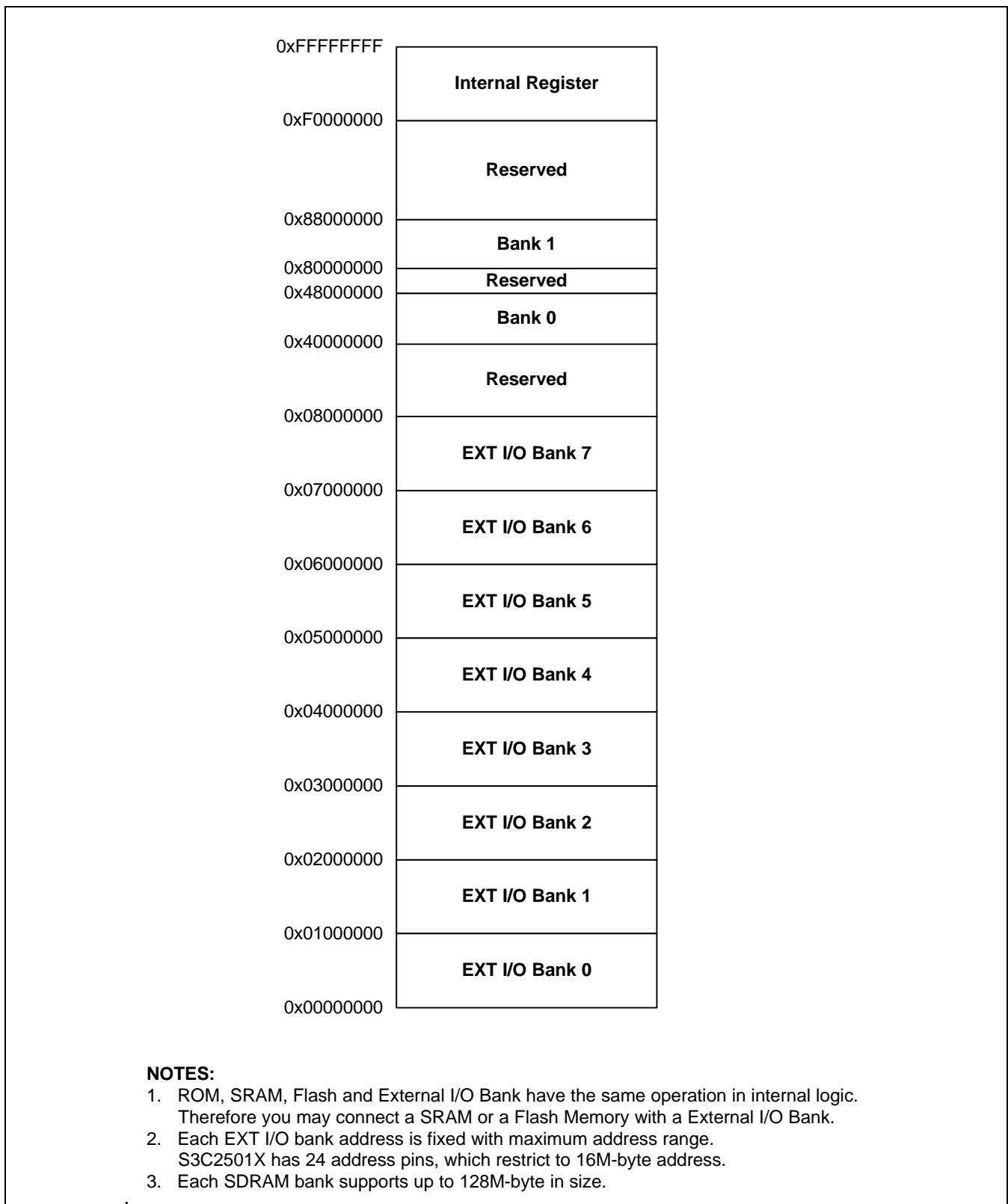

Figure 5-1. Memory Bank Address map

5.4 BUS INTERFACE SIGNALS

The bus interface signals transfer information between the S3C2501X and external memory device. These divide into address and data which used commonly, SDRAM interface signals for SDRAM and memory device interface for ROM/SRAM, etc.

For detail description for the bus interface signals, refer to the table below.

Table 5-2. Bus Interface Signals

Signal Name	Pins	Active	I/O	Description
ADDR	24	HIGH	O	Specifies the physical address of the external device
DATA	32	HIGH	B	Specifies data of the external device
B0SIZE	2	HIGH	I	Specifies data bus access size for the Bank 0
nOE	1	LOW	O	Specifies read/write state from S3C2501X. When S3C2501X read from ext I/O device, nOE's value is 1'b0.
nRCS	8	LOW	O	Specifies which ext I/O device is selected.
nEWAIT/nREADY	1	LOW	I	Signal be controlled from ext I/O slow device to delay cycles in data read and write.
HCLKO	1	HIGH	O	S3C2501X system clock out
CKE	1	HIGH	O	Clock enable for SDRAM
nSDCS	2	LOW	O	Chip select strobe for SDRAM
nSDRAS	1	LOW	O	Row address strobe for SDRAM
nSDCAS	1	LOW	O	Column address strobe for SDRAM
nWBE/nBE/DQM	4	LOW	O	Write byte enable
nSDWE/nWE16	1	LOW	O	Write enable for ROM, SRAM, Flash that have 16bit-data width and SDRAM.
XBMREQ	1	HIGH	I	External Master bus request
XBMACK	1	HIGH	O	External bus acknowledge

NOTES:

1. O = Output from the S3C2501X.
2. I = Input to the S3C2501X.
3. B = Bi-direction.

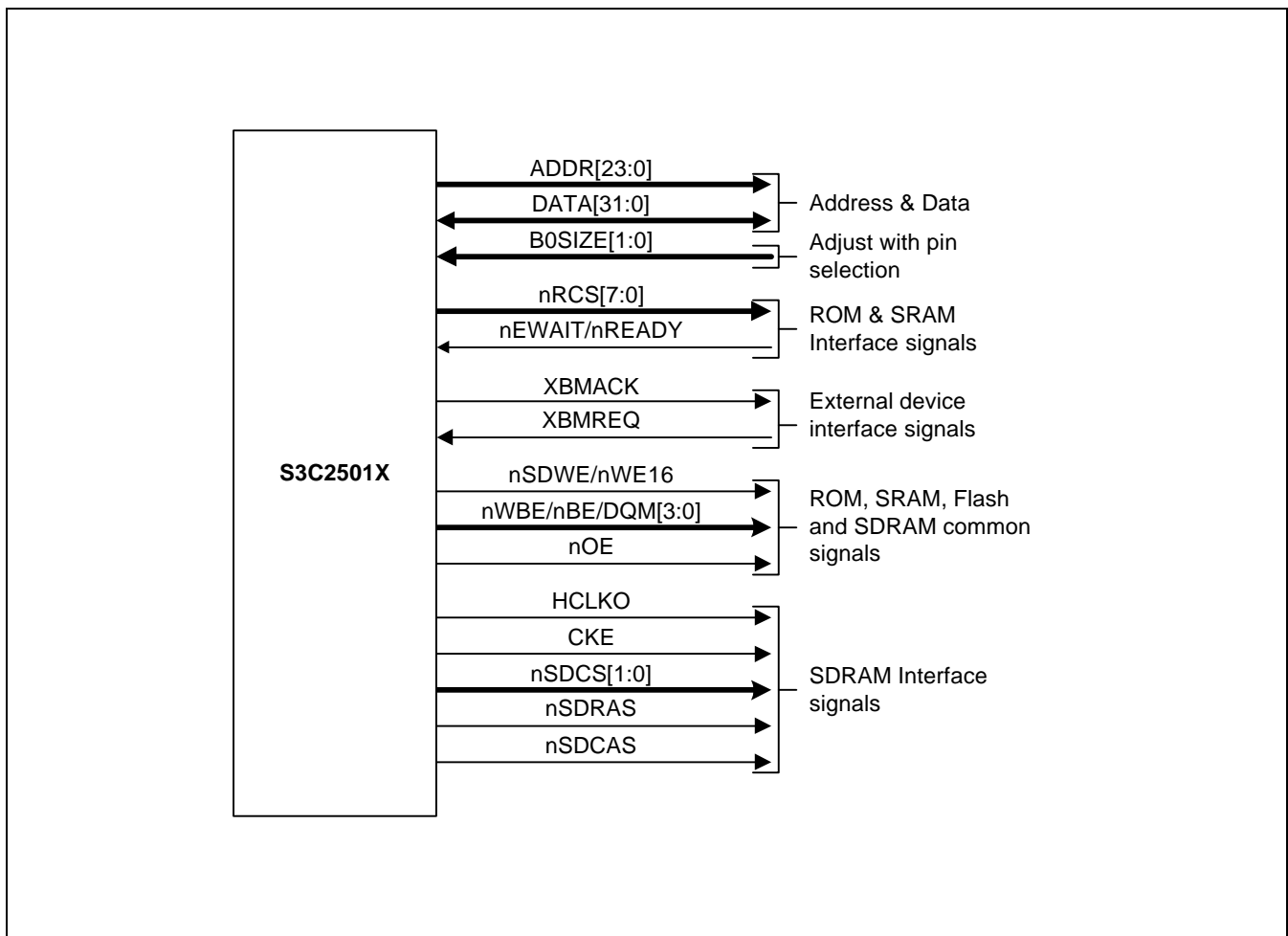

Figure 5-2. Memory Controller Bus Signals

5.5 ENDIAN MODES

S3C2501X supports both little-endian and big-endian for external memory or I/O devices by setting the pin BIG.

Below tables(5-3 through 5-14) are show the program/data path between the CPU register and the external memory using little-/big-endian and word/half-word/byte access.

Table 5-3 and 5-4.

Using big-endian and word access, Program/Data path between register and external memory.

WA=Address whose LSB is 0, 4, 8, C, HA=Address whose LSB is 0, 2, 4, 6, 8, A, C, E

BA=Address whose LSB is 0, 1, 2, 3, 4, 5, 6, 7, 8, 9, A, B, C, D, E, F

EA=External Address X=Don't care

Table 5-3. External 32-bit Datawidth Store Operation with Big-Endian

Transfer Width	STORE (CPU Reg → External Memory)						
	32-bit	16-bit		8-bit			
Bit Num. CPU Register Data	31 0 abcd	31 0 xxab	31 0 xxcd	31 0 xxxa	31 0 xxxb	31 0 xxxc	31 0 xxxd
CPU Address	WA	HA	HA+1	BA	BA+1	BA+2	BA+3
Bit Num. CPU Data Bus	31 0 abcd	31 0 abab	31 0 cdcd	31 0 aaaa	31 0 bbbb	31 0 cccc	31 0 dddd
External Address (ADDR)	EA						
Bit Num. External DATA	31 0 dcba	31 0 xxba	31 0 dcxx	31 0 xxxa	31 0 xxbx	31 0 xcxx	31 0 dxxx
Timing Sequence							

Table 5-4. External 32-bit Datawidth Load Operation with Big-Endian

Transfer Width	LOAD (CPU Reg ← External Memory)						
	32-bit	16-bit		8-bit			
Bit Num. CPU Register Data	31 0 abcd	31 0 xxab	31 0 xxcd	31 0 xxxa	31 0 xxxb	31 0 xxxc	31 0 xxxd
CPU Address	WA	HA	HA+1	BA	BA+1	BA+2	BA+3
Bit Num. CPU Data Bus	31 0 abcd	31 0 abab	31 0 cdcd	31 0 aaaa	31 0 bbbb	31 0 cccc	31 0 dddd
External Address (ADDR)	EA						
Bit Num. External DATA	31 0 dcba	31 0 dcba		31 0 dcba			
Timing Sequence							

Table 5-5 and 5-6.

Using big-endian and half-word access, Program/Data path between register and external memory.

WA=Address whose LSB is 0, 4, 8, C, EA=External Address

HA=Address whose LSB is 0, 2, 4, 6, 8, A, C, E

BA=Address whose LSB is 0, 1, 2, 3, 4, 5, 6, 7, 8, 9, A, B, C, D, E, F

X=Don't care.

Table 5-5. External 16-bit Datawidth Store Operation with Big-Endian

Transfer Width	STORE (CPU Reg → External Memory)				
	32-bit		16-bit	8-bit	
Bit Num. CPU Register Data	31 0 abcd		31 0 xxab	31 0 xxxa	31 0 xxxb
CPU Address	WA		HA	BA	BA+1
Bit Num. CPU Data Bus	31 0 abcd		31 0 abab	31 0 aaaa	31 0 bbbb
External Address (ADDR)	EA	EA+1	EA	EA	
Bit Num. External DATA	15 0 ba	15 0 dc	15 0 ba	15 0 xa	15 0 bx
Timing Sequence	1st	2nd			

Table 5-6. External 16-bit Datawidth Load Operation with Big-Endian

Transfer Width	LOAD (CPU Reg ← External Memory)				
	32-bit		16-bit	8-bit	
Bit Num. CPU Register Data	31 0 abcd		31 0 xxab	31 0 xxxa	31 0 xxxb
CPU Address	WA		HA	BA	BA+1
Bit Num. CPU Data Bus	31 0 abxx	31 0 abcd	31 0 abab	31 0 aaaa	31 0 bbbb
External Address (ADDR)	EA	EA + 1	EA	EA	
Bit Num. External DATA	15 0 ba	15 0 dc	15 0 ba	15 0 ba	
Timing Sequence	1st	2nd			

Table 5-7 and 5-8.

Using big-endian and byte access, Program/Data path between register and external memory.

WA=Address whose LSB is 0, 4, 8, C, EA=External Address

HA=Address whose LSB is 0, 2, 4, 6, 8, A, C, E

BA=Address whose LSB is 0, 1, 2, 3, 4, 5, 6, 7, 8, 9, A, B, C, D, E, F

X=Don't care.

Table 5-7. External 8-bit Datawidth Store Operation with Big-Endian

Transfer Width	STORE (CPU Reg → External Memory)						
	32-bit				16-bit		8-bit
Bit Num. CPU Register Data	31 0 abcd				15 0 xxab		7 0 xxxa
CPU Address	WA				HA		BA
Bit Num. CPU Data Bus	31 0 abcd				31 0 abab		31 0 aaaa
External Address	EA	EA+1	EA+2	EA+3	EA	EA+1	EA
Bit Num. External DATA	7 0 a	7 0 b	7 0 c	7 0 d	7 0 a	7 0 b	7 0 a
Timing Sequence	1st	2nd	3rd	4th	1st	2nd	

Table 5-8. External 8-bit Datawidth Load Operation with Big-Endian

Transfer Width	LOAD (CPU Reg ← External Memory)						
	32-bit				16-bit		8-bit
Bit Num. CPU Register Data	31 0 abcd				15 0 xxab		7 0 xxxa
CPU Address	WA				HA		BA
Bit Num. CPU Data Bus	31 0 axxxx	31 0 abxx	31 0 abcx	31 0 abcd	31 0 axax	31 0 abab	31 0 aaaa
External Address	EA	EA+1	EA+2	EA+3	EA	EA+1	EA
Bit Num. External DATA	7 0 a	7 0 b	7 0 c	7 0 d	7 0 a	7 0 b	7 0 a
Timing Sequence	1st	2nd	3rd	4th	1st	2nd	

Table 5-9 and 5-10.

Using little-endian and word access, Program/Data path between register and external memory.

WA=Address whose LSB is 0, 4, 8, C, EA=External Address

HA=Address whose LSB is 0, 2, 4, 6, 8, A, C, E

BA=Address whose LSB is 0, 1, 2, 3, 4, 5, 6, 7, 8, 9, A, B, C, D, E, F

X=Don't care

Table 5-9. External 32-bit Datwidth Store Operation with Little-Endian

Transfer Width	STORE (CPU Reg → External Memory)						
	32-bit	16-bit		8-bit			
Bit Num. CPU Register Data	31 0 abcd	31 0 xxcd	31 0 xxab	31 0 xxxd	31 0 xxxc	31 0 xxxb	31 0 xxxa
CPU Address	WA	HA	HA+1	BA	BA+1	BA+2	BA+3
Bit Num. CPU Data Bus	31 0 abcd	31 0 cdcd	31 0 abab	31 0 dddd	31 0 cccc	31 0 bbbb	31 0 aaaa
External Address (ADDR)	EA						
Bit Num. External DATA	31 0 abcd	31 0 xxcd	31 0 abxx	31 0 xxxd	31 0 xxcx	31 0 xbxx	31 0 axxx
Timing Sequence							

Table 5-10. External 32-bit Datwidth Load Operation with Little-Endian

Transfer Width	LOAD (CPU Reg ← External Memory)						
	32-bit	16-bit		8-bit			
Bit Num. CPU Register Data	31 0 abcd	31 0 xxcd	31 0 xxab	31 0 xxxd	31 0 xxxc	31 0 xxxb	31 0 xxxa
CPU Address	WA	HA	HA+1	BA	BA+1	BA+2	BA+3
Bit Num. CPU Data Bus	31 0 abcd	31 0 cdcd	31 0 abab	31 0 dddd	31 0 cccc	31 0 bbbb	31 0 aaaa
External Address (ADDR)	EA						
Bit Num. External DATA	31 0 abcd	31 0 abcd		31 0 abcd			
Timing Sequence							

Table 5-11 and 5-12.

Using little-endian and half-word access, Program/Data path between register and external memory.

WA=Address whose LSB is 0, 4, 8, C, EA=External Address

HA=Address whose LSB is 0, 2, 4, 6, 8, A, C, E

BA=Address whose LSB is 0, 1, 2, 3, 4, 5, 6, 7, 8, 9, A, B, C, D, E, F

X=Don't care.

Table 5-11. External 16-bit Datawidth Store Operation with Little-Endian

Transfer Width	STORE (CPU Reg → External Memory)				
	32-bit		16-bit	8-bit	
Bit Num. CPU Register Data	31 0 abcd		31 0 xxab	31 0 xxx b	31 0 xxx a
CPU Address	WA		HA	BA	BA+1
Bit Num. CPU Data Bus	31 0 abcd		31 0 abab	31 0 bbb b	31 0 aaa a
External Address (ADDR)	EA+1	EA	EA	EA	
Bit Num. External DATA	15 0 ab	15 0 cd	15 0 ab	15 0 xb	15 0 ax
Timing Sequence	1st	2nd			

Table 5-12. External 16-bit Datawidth Load Operation with Little-Endian

Transfer Width	LOAD (CPU Reg ← External Memory)				
	32-bit		16-bit	8-bit	
Bit Num. CPU Register Data	31 0 abcd		31 0 xxab	31 0 xxx b	31 0 xxx a
CPU Address	WA		HA	BA	BA+1
Bit Num. CPU Data Bus	31 0 ab xx	31 0 abcd	31 0 abab	31 0 bbb b	31 0 aaa a
External Address (ADDR)	EA + 1	EA	EA	EA	
Bit Num. External DATA	15 0 ab	15 0 cd	15 0 ab	15 0 ab	
Timing Sequence	1st	2nd			

Table 5-13 and 5-14.

Using little-endian and byte access, Program/Data path between register and external memory.

WA=Address whose LSB is 0, 4, 8, C, EA=External Address

HA=Address whose LSB is 0, 2, 4, 6, 8, A, C, E

BA=Address whose LSB is 0, 1, 2, 3, 4, 5, 6, 7, 8, 9, A, B, C, D, E, F

X=Don't care.

Table 5-13. External 8-bit Datawidth Store Operation with Little-Endian

Transfer Width	STORE (CPU Reg → External Memory)						
	32-bit				16-bit		8-bit
Bit Num. CPU Register Data	31 0 abcd				31 0 xxab		31 0 xxxa
CPU Address	WA				HA		BA
Bit Num. CPU Data Bus	31 0 abcd				31 0 abab		31 0 aaaa
External Address (ADDR)	EA+3	EA+2	EA+1	EA	EA+1	EA	EA
Bit Num. External DATA	7 0 a	7 0 b	7 0 c	7 0 d	7 0 a	7 0 b	7 0 a
Timing Sequence	1st	2nd	3rd	4th	1st	2nd	

Table 5-14. External 8-bit Datawidth Load Operation with Little-Endian

Transfer Width	LOAD (CPU Reg ← External Memory)						
	32-bit				16-bit		8-bit
Bit Num. CPU Register Data	31 0 abcd				31 0 xxab		31 0 xxxa
CPU Address	WA				HA		BA
Bit Num. CPU Data Bus	31 0 axxxx	31 0 abxx	31 0 abcx	31 0 abcd	31 0 axax	31 0 abab	31 0 aaaa
External Address (ADDR)	EA+3	EA+2	EA+1	EA	EA+1	EA	EA
Bit Num. External DATA	7 0 a	7 0 b	7 0 c	7 0 d	7 0 a	7 0 b	7 0 a
Timing Sequence	1st	2nd	3rd	4th	1st	2nd	

5.6 EXT I/O BANK CONTROLLER

Ext I/O Bank controller can be interfacing ROM, SRAM, flash memory, etc, except SDRAM. It also supports muxed bus memory device which shares address bus and data bus. Ext I/O bank controller has three kind of the register for eight banks and then it can be controlled by various timing control options.

5.6.1 FEATURES

The following is a list of the Ext I/O Bank Controller's features:

- 8 banks
- ROM / SRAM / Flash Memory / External I/O interface
- 16M-byte maximum address range per bank (24-bit external address pins)
- 32-bit internal and external data bus
- Various timing control options

5.6.2 EXTERNAL DEVICE CONNECTION

Figure 5-3. illustrates a simple connection between 8-bit ROM/Flash and S3C2501X.

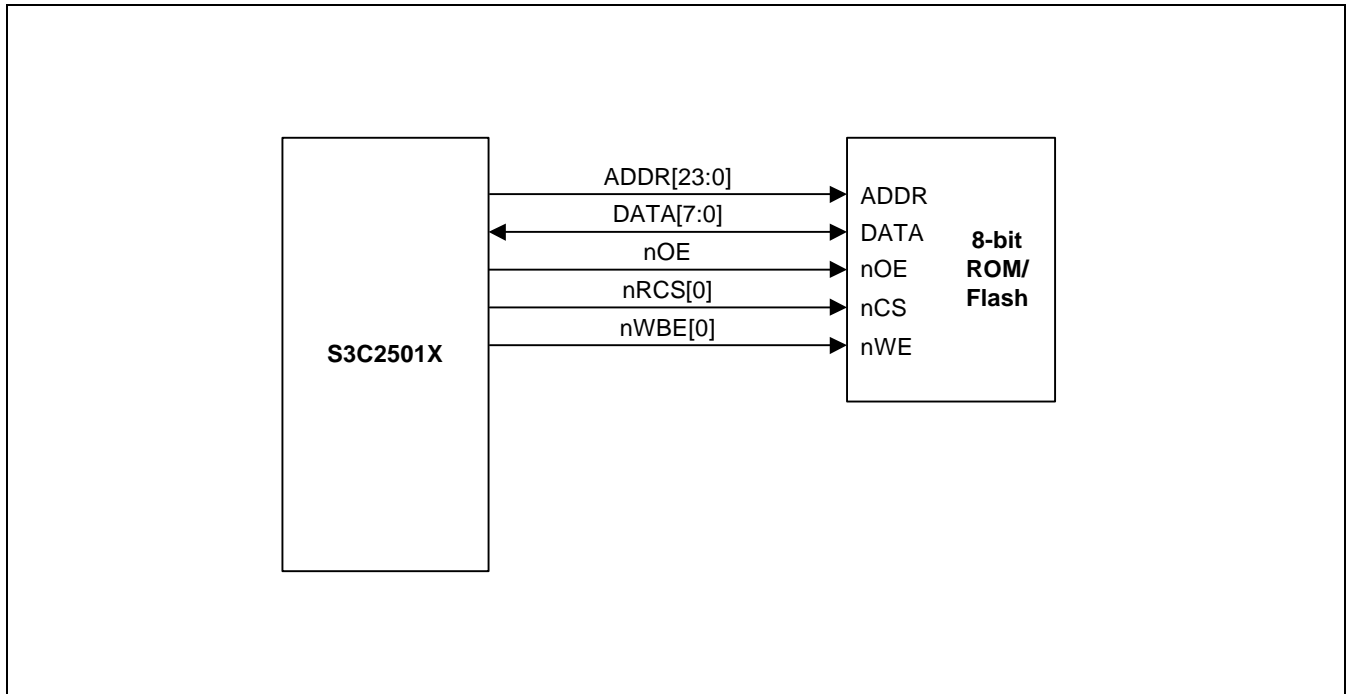

Figure 5-3. 8-bit ROM, SRAM and Flash Basic Connection

Figure 5-4. illustrates a example connection between two of 8-bit ROM/Flash and S3C2501X for the consisting of 16-bit ROM/SRAM/Flash.

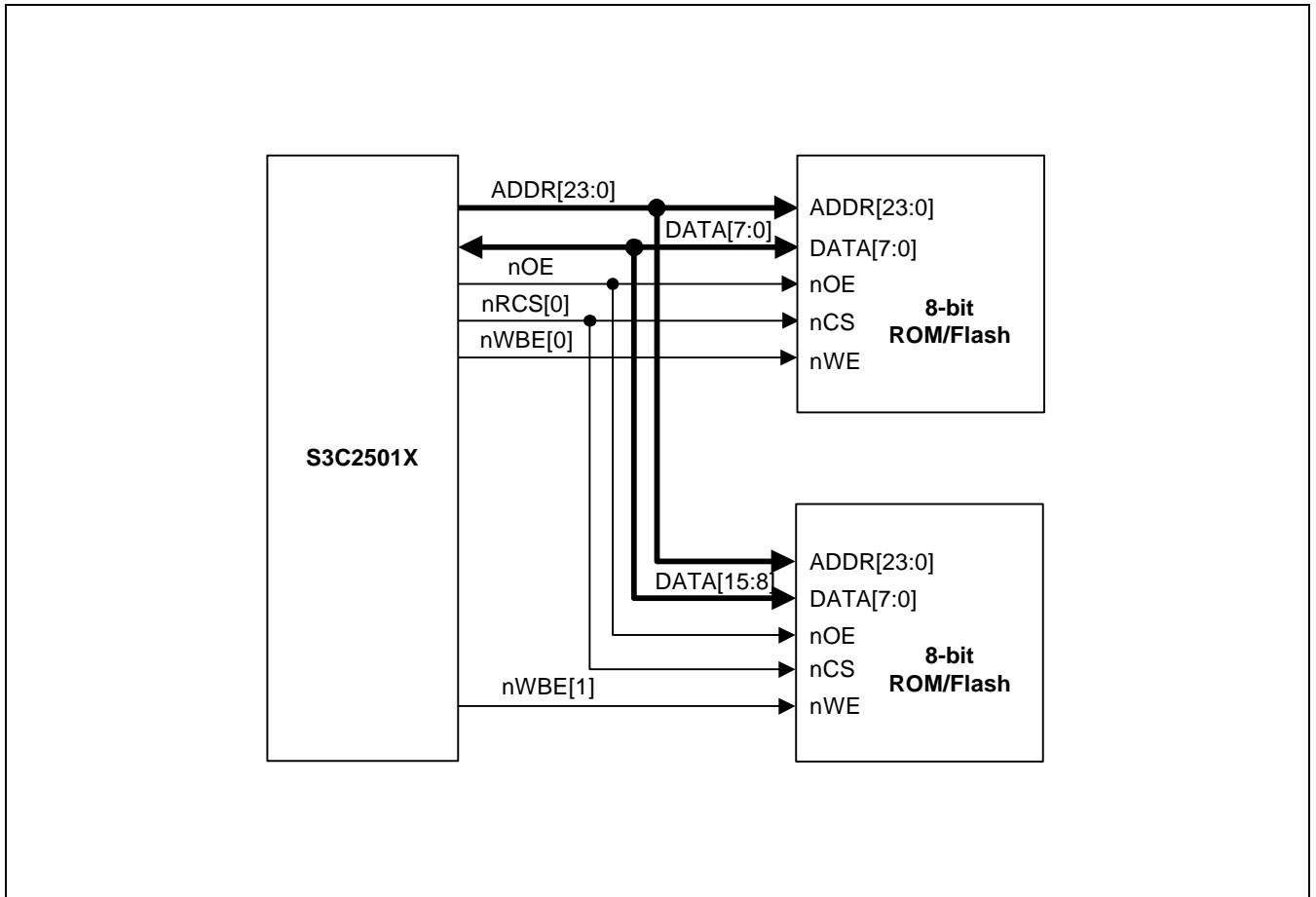

Figure 5-4. 8-bit ROM, SRAM and Flash Basic Connection (8-bit Memory x 2)

Figure 5-5. illustrates a connection between 16-bit ROM/SRAM and S3C2501X.

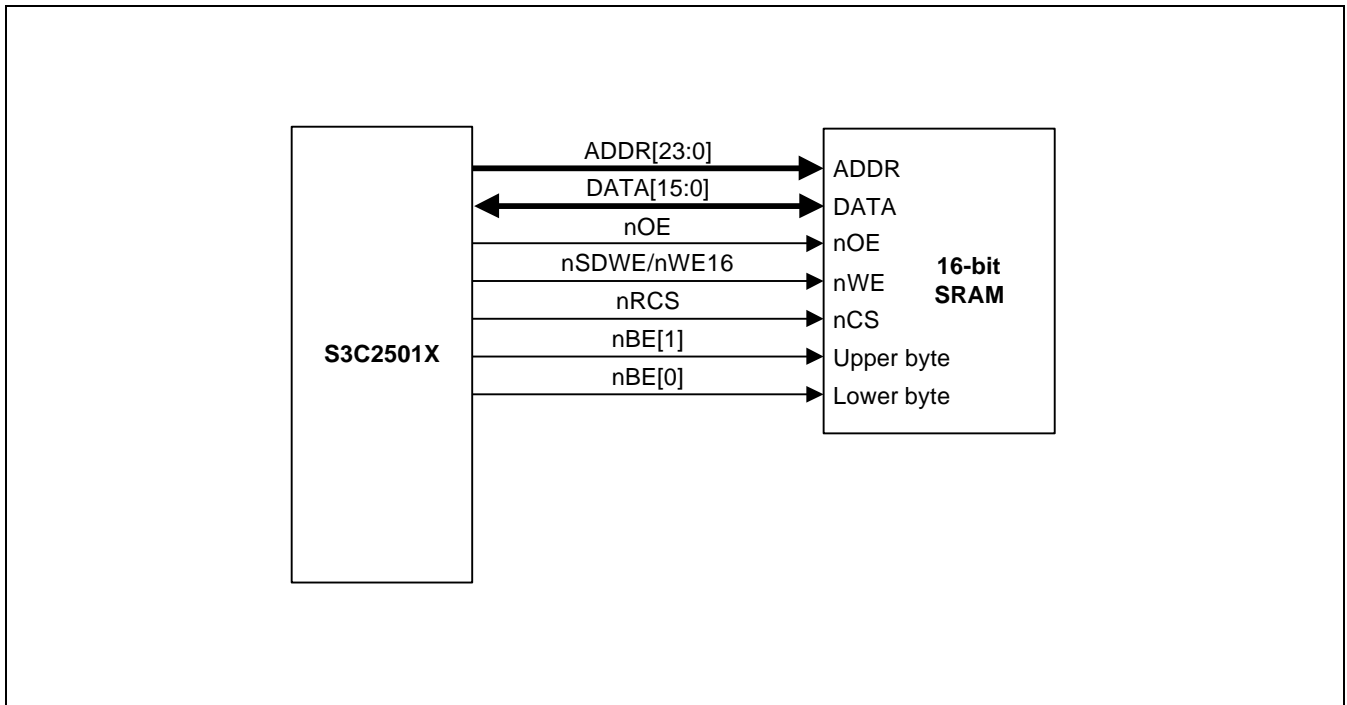

Figure 5-5. 16-bit SRAM Basic Connection

Figure 5-6. illustrates a connection between 16-bit ROM/Flash and S3C2501X.

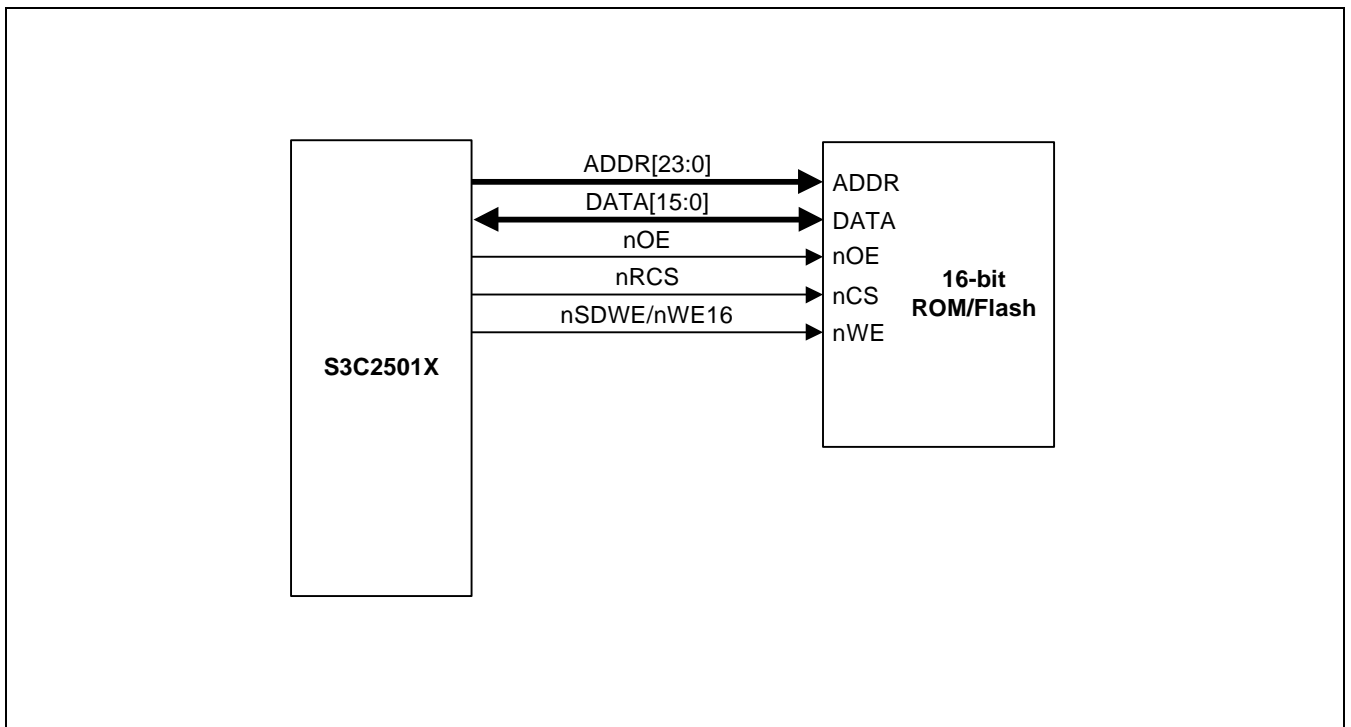

Figure 5-6. 16-bit ROM and Flash Basic Connection

Figure 5-7. illustrates a connection between 16-bit ROM and S3C2501X.

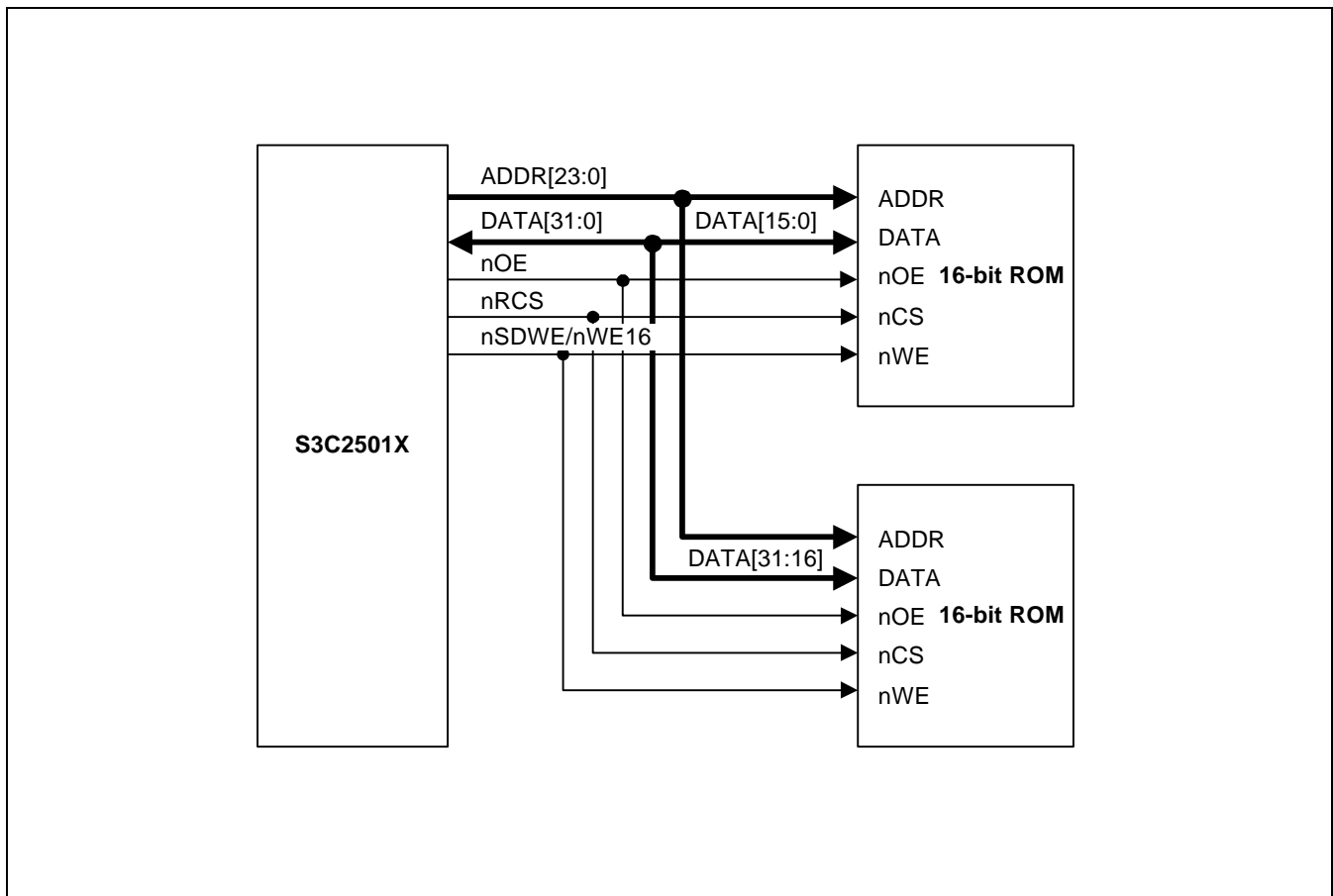

Figure 5-7. 16-bit ROM Basic Connection 2

Figure 5-8. illustrates a connection between 16-bit SRAM and S3C2501X.

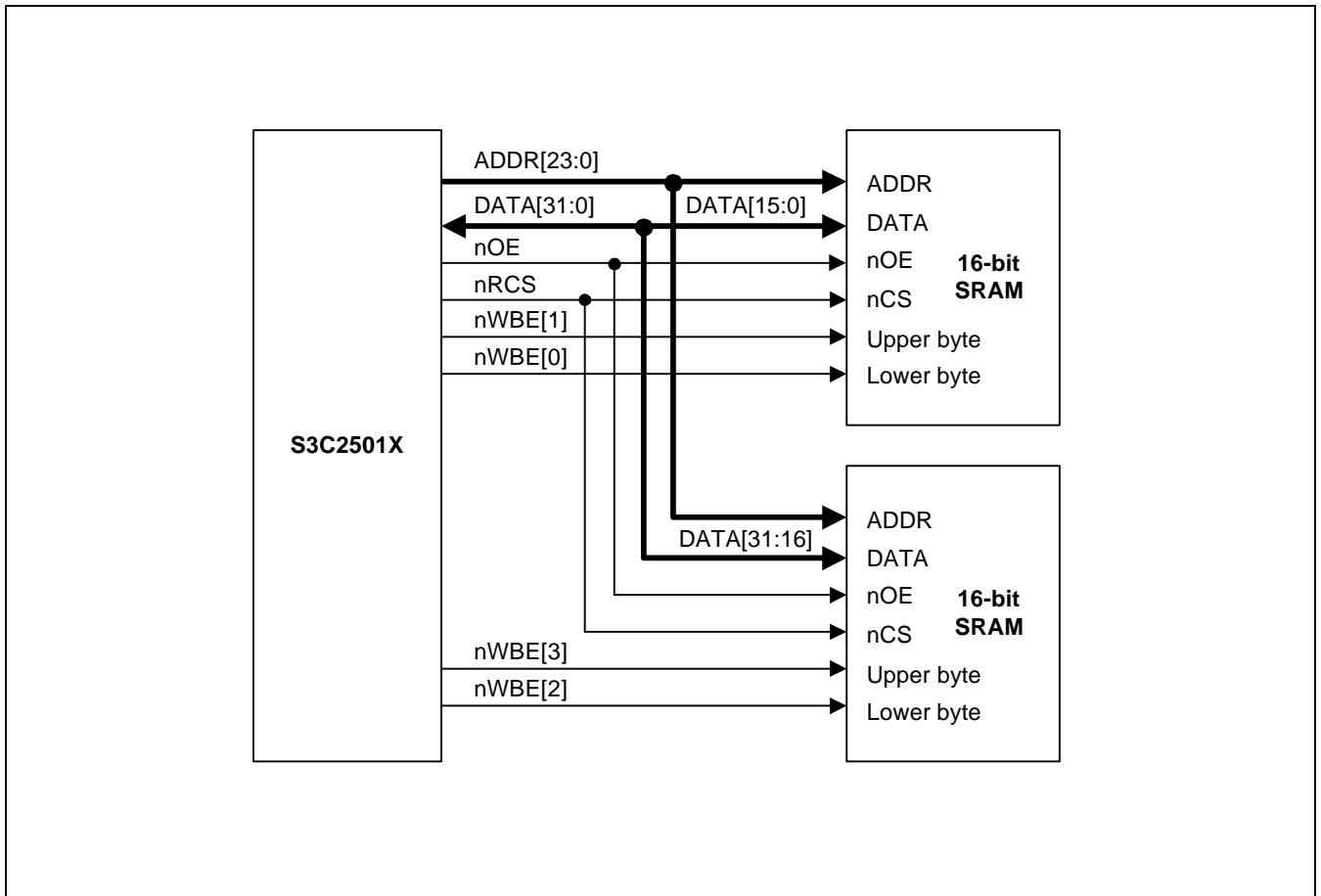

Figure 5-8. 16-bit SRAM Basic Connection 2

Figure 5-9. illustrates a connection between S3C2501X and muxed bus ROM & SRAM.

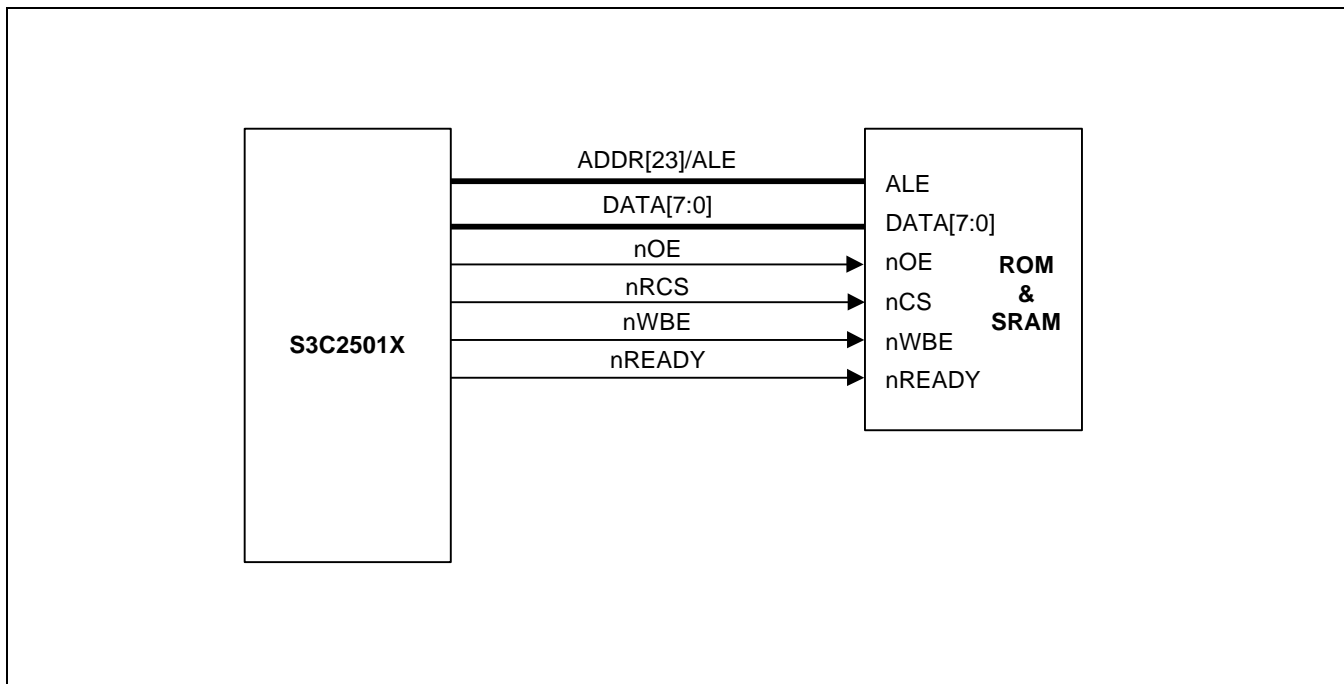

Figure 5-9. ROM & SRAM with Muxed Address & Data Bus Connection

NOTE

If the external I/O use nReady signal instead of nWait, you must select nReady in WAITCON register of memory controller.

ADDR[23] bit is used the address latch enable(ALE) signal to latch an address for the ROM and SRAM which have the muxed bus structure.

5.6.3 EXT. I/O BANK CONTROLLER SPECIAL REGISTER

To control the external memory operations, the memory controller uses a dedicated set of special registers (see Table 5-15). By programming the values in the memory controller special registers, you can specify such things as

- Memory type
- External bus width selection
- Control signal timing
- Ext I/O access cycles control
- The sizes of memory banks to be used for arbitrary address spacing

The memory controller uses some special registers to control the generation and processing of the control signals, addresses, and data that are required by the external devices in a standard system configuration. The special registers are also used to control access to all banks.

Table 5-15. Ext. I/O Bank Controller Special Registers

Name	Address	Description	Reset Value
B0CON	0xF0010000	Bank 0 control register	0xC514E488 (B0SIZE=3) 0x8514E488 (B0SIZE=2) 0x4514E488 (B0SIZE=1)
B1CON	0xF0010004	Bank 1 control register	0xC514E488
B2CON	0xF0010008	Bank 2 control register	0xC514E488
B3CON	0xF001000C	Bank 3 control register	0xC514E488
B4CON	0xF0010010	Bank 4 control register	0xC514E488
B5CON	0xF0010014	Bank 5 control register	0xC514E488
B6CON	0xF0010018	Bank 6 control register	0xC514E488
B7CON	0xF001001C	Bank 7 control register	0xC514E488
MUXBCON	0xF0010020	Muxed bus control register	0x006DB6DB
WAITCON	0xF0010024	Wait control register	0x00000000

NOTE: B0SIZE means the size of physical data bus width in Bank 0. Refer to the next page.

5.6.3.1 Ext I/O Bank Access Control Registers (BnCON)

The Ext I/O Bank controller has eight external I/O access control registers. These registers correspond to up to eight external I/O banks that are supported by S3C2501X. Table 5-16 describes eight registers that are used to control the timing of external I/O bank accesses.

The external I/O access cycles can be controlled by using either a specified value or an external wait signal, nEWAIT. Especially, to obtain access cycles that are longer than TACC of 31 cycles, you can delay the active time of nOE or nWBE by nEWAIT assertion. In case of ROM bank, nOE/nWBE signals are activated simultaneously; that is, there is no control parameter as like TCOS.

Address setup time(TACS) can be used when the external memory access is handled by the nOE assertion to be delayed. Thus the external memory may use more stable address. Access cycles(TACC) extend nCS cycles to access external memory. After nOE is deasserted, chip selection hold time(TCOH) can be used when nCS is keep up.

B0CON is used to set the external access timings for external I/O bank 0. B1CON is used to set the external access timing for I/O bank 1, and so on.

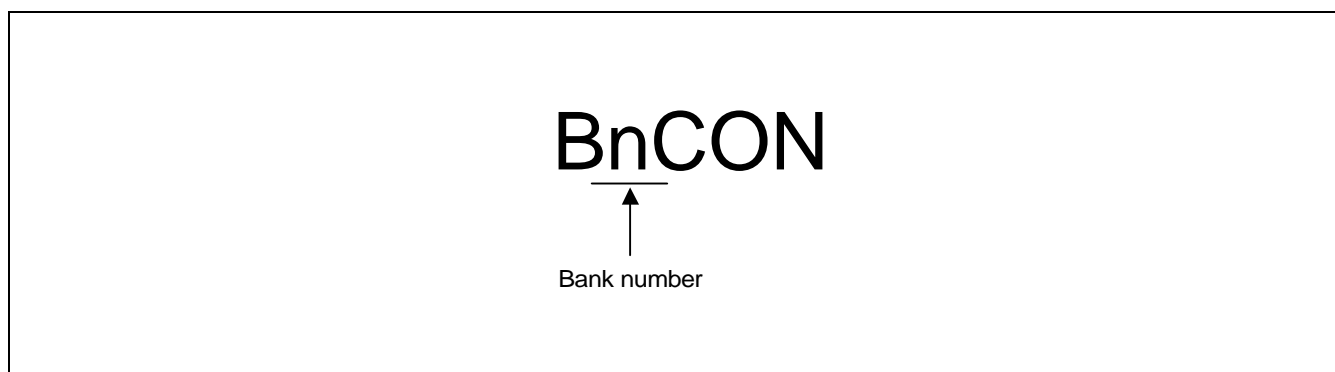

Figure 5-10. BnCON

The Ext I/O Bank controller has eight kind control registers for ROM, SRAM, and flash memory (see Table 5-16). These registers correspond to up to eight ROM/SRAM/Flash banks that are supported by S3C2501X.

For ROM/SRAM/Flash bank 0, the external data bus width is determined by the signal at the B0SIZE pins:

When B0SIZE[1:0] = "01", the external bus width for ROM/SRAM/Flash bank 0 is 8 bits.

When B0SIZE[1:0] = "10", the external bus width for ROM/SRAM/Flash bank 0 is 16 bits.

When B0SIZE[1:0] = "11", the external bus width for ROM/SRAM/Flash bank 0 is 32 bits.

BnCON register configuration is described in Figure 5-11.

Table 5-16. Bank n Control (BnCON) Register

Register	Address	R/W	Description	Reset Value
B0CON	0xF0010000	R/W	Bank 0 control register	0xC514E488 (B0SIZE=3) 0x8514E488 (B0SIZE=2) 0x4514E488 (B0SIZE=1)
B1CON	0xF0010004	R/W	Bank 1 control register	0xC514E488
B2CON	0xF0010008	R/W	Bank 2 control register	0xC514E488
B3CON	0xF001000C	R/W	Bank 3 control register	0xC514E488
B4CON	0xF0010010	R/W	Bank 4 control register	0xC514E488
B5CON	0xF0010014	R/W	Bank 5 control register	0xC514E488
B6CON	0xF0010018	R/W	Bank 6 control register	0xC514E488
B7CON	0xF001001C	R/W	Bank 7 control register	0xC514E488

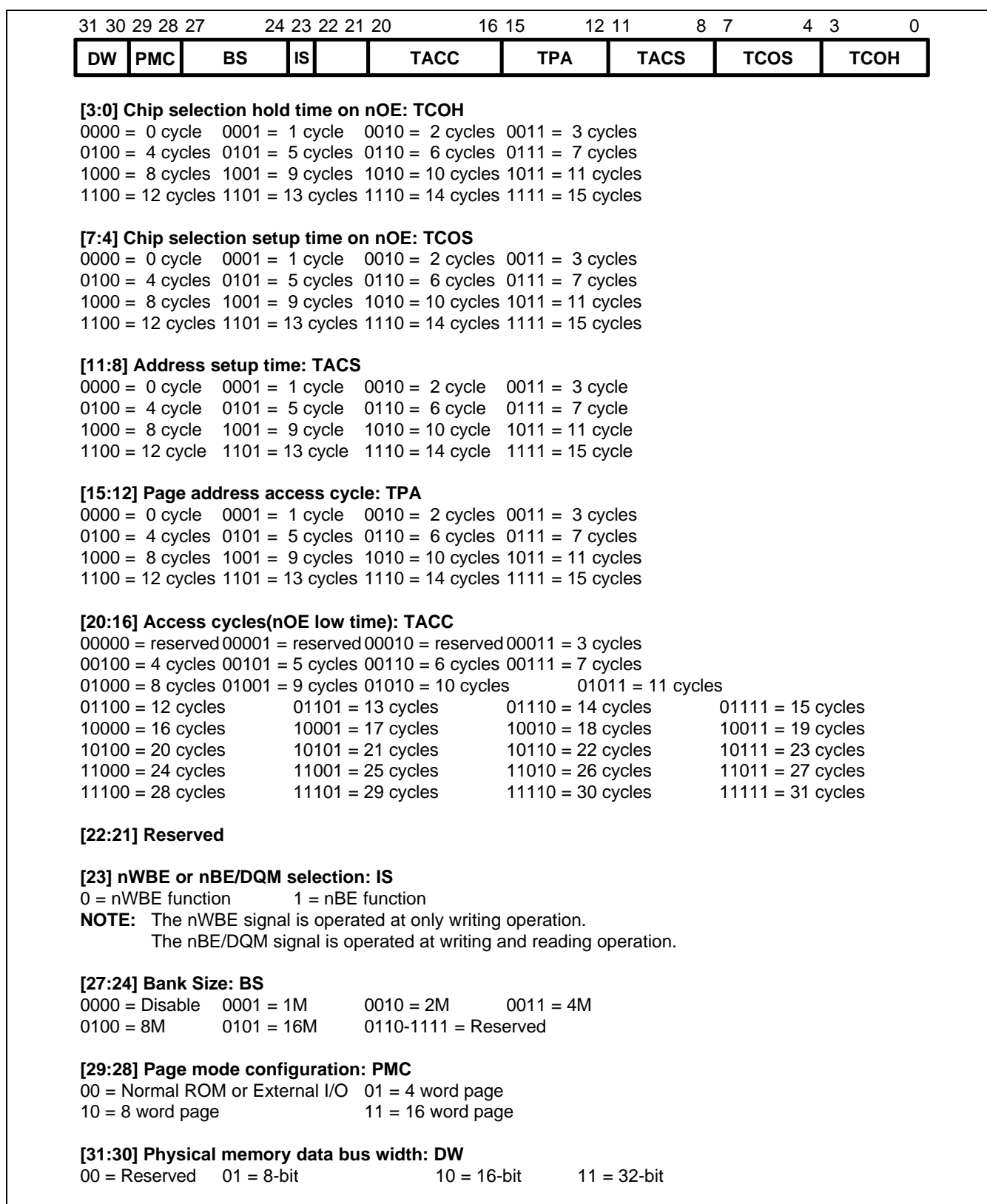

Figure 5-11. Bank n Control (BnCON) Register Configuration

NOTE

1. If WAITEN of WAITCON register is enable, memory controller can't finish access cycle until nEWAIT signal is high. If you use slow device, you can set WAITEN to '1' and control nEWAIT signal. The memory controller checks nEWAIT signal at the last cycle of TACC. If you set WAITEN to '0', the nEWAIT signal is ignored.
2. You can use memory control signals such as nCS, nWBE, nOE, nEWAIT for 8 bit memory, and nCS, nWE16, nOE, nEWAIT for 16 bit memory.
3. The DW of bank 0 is the same with B0SIZE[1:0] pin. That is read only value. The initial value of other banks is "11".

5.6.3.2 Muxed bus control register

Ext I/O Bank controller supports memory devices which have the muxed bus interface. To use muxed bus memory device, muxed bus enable(MBE) and muxed bus address cycle(TMA) for each bank in MUXBCON register must be set.

Table 5-17. Muxed Bus Control Register

Register	Address	R/W	Description	Reset Value
MUXBCON	0xF0010020	R/W	Muxed bus control register	0x006DB6DB

31	30	29	28	27	26	25	24	23	21	20	18	17	15	14	12	11	9	8	6	5	3	2	0
M	M	M	M	M	M	M	M	M	T	T	T	T	T	T	T	T	T	T	T	T	T	T	T
B	B	B	B	B	B	B	B	B	M	M	M	M	M	M	M	M	M	M	M	M	M	M	M
E	E	E	E	E	E	E	E	E	A	A	A	A	A	A	A	A	A	A	A	A	A	A	A
7	6	5	4	3	2	1	0		7	6	5	4	3	2	1	0							

[2-0] Muxed bus address cycle for bank 0: TMA0

001 = 1 cycle 010 = 2 cycles 011 = 3 cycles 100 = 4 cycles
 101 = 5 cycles 110 = 6 cycles 111 = 7 cycles 000 = 8 cycles

[5-3] Muxed bus address cycle for bank 1: TMA1

001 = 1 cycle 010 = 2 cycles 011 = 3 cycles 100 = 4 cycles
 101 = 5 cycles 110 = 6 cycles 111 = 7 cycles 000 = 8 cycles

[8-6] Muxed bus address cycle for bank 2: TMA2

001 = 1 cycle 010 = 2 cycles 011 = 3 cycles 100 = 4 cycles
 101 = 5 cycles 110 = 6 cycles 111 = 7 cycles 000 = 8 cycles

[11-9] Muxed bus address cycle for bank 3: TMA3

001 = 1 cycle 010 = 2 cycles 011 = 3 cycles 100 = 4 cycles
 101 = 5 cycles 110 = 6 cycles 111 = 7 cycles 000 = 8 cycles

[14-12] Muxed bus address cycle for bank 4: TMA4

001 = 1 cycle 010 = 2 cycles 011 = 3 cycles 100 = 4 cycles
 101 = 5 cycles 110 = 6 cycles 111 = 7 cycles 000 = 8 cycles

[17-15] Muxed bus address cycle for bank 5: TMA5

001 = 1 cycle 010 = 2 cycles 011 = 3 cycles 100 = 4 cycles
 101 = 5 cycles 110 = 6 cycles 111 = 7 cycles 000 = 8 cycles

[20-18] Muxed bus address cycle for bank 6: TMA6

001 = 1 cycle 010 = 2 cycles 011 = 3 cycles 100 = 4 cycles
 101 = 5 cycles 110 = 6 cycles 111 = 7 cycles 000 = 8 cycles

[23-21] Muxed bus address cycle for bank 7: TMA7

001 = 1 cycle 010 = 2 cycles 011 = 3 cycles 100 = 4 cycles
 101 = 5 cycles 110 = 6 cycles 111 = 7 cycles 000 = 8 cycles

[24] Address / Data muxed bus enable for bank 0: MBE0

0 = disable 1 = enable

[25] Address / Data muxed bus enable for bank 1: MBE1

0 = disable 1 = enable

[26] Address / Data muxed bus enable for bank 2: MBE2

0 = disable 1 = enable

[27] Address / Data muxed bus enable for bank 3: MBE3

0 = disable 1 = enable

[28] Address / Data muxed bus enable for bank 4: MBE4

0 = disable 1 = enable

[29] Address / Data muxed bus enable for bank 5: MBE5

0 = disable 1 = enable

[30] Address / Data muxed bus enable for bank 6: MBE6

0 = disable 1 = enable

[31] Address / Data muxed bus enable for bank 7: MBE7

0 = disable 1 = enable

Figure 5-12. Muxed Bus Control (MUXBCON) Register Configuration

5.6.3.3 Wait Control Register

Slow external I/O devices requiring a long delay cycles on data read and write, should set EWAITENn in the WAITCON register. (In this case nEWAIT pin should connected to the external I/O device, if multiple slow external I/O devices are connected to nEWAIT, each WAIT signals of external I/O devices should be or.) nEWAIT is low active signal. When nEWAIT is a low, S3C2501X is waiting until nEWAIT is high again.

nREADY in the WAITCON register is used when the external I/O device is ready for transferring data. When nREADY is low, S3C2501X transfers data.

In addition, Ext I/O controller provides COHDIS in the WAITCON register. When this COHDIS is enabled as '1', Ext I/O controller disables chip selection hold time(TCOH) while access the same bank except first access cycle. So, TCOHDIS helps you to access slow External I/O devices more quickly. Performance by using COHDIS in the WAITCON register when slow External I/O is used, could be improved. If you use slow External I/O, you must set TCOH to a proper value because you have to prevent the data collision. But, when you set TCOH to a non-zero value, all types of data access in the selected bank have TCOH cycle time. So although write to write, read to read, and write to read access don't have to use TCOH cycle, memory controller extends chip select signal during TCOH cycle. It decreases the system performance. In S3C2501X, to improve this operation, we add TCOHDIS field. If you set COHDIS to '1', although TCOH isn't zero, TCOH is ignored in write to write, read to read, and write to read access. In those case memory controller operates as if TCOH is zero.

Table 5-18. WAIT Control Register

Register	Address	R/W	Description	Reset Value
WAITCON	0xF0010024	R/W	Wait control register	0x00000000

5.6.4 TIMING DIAGRAM

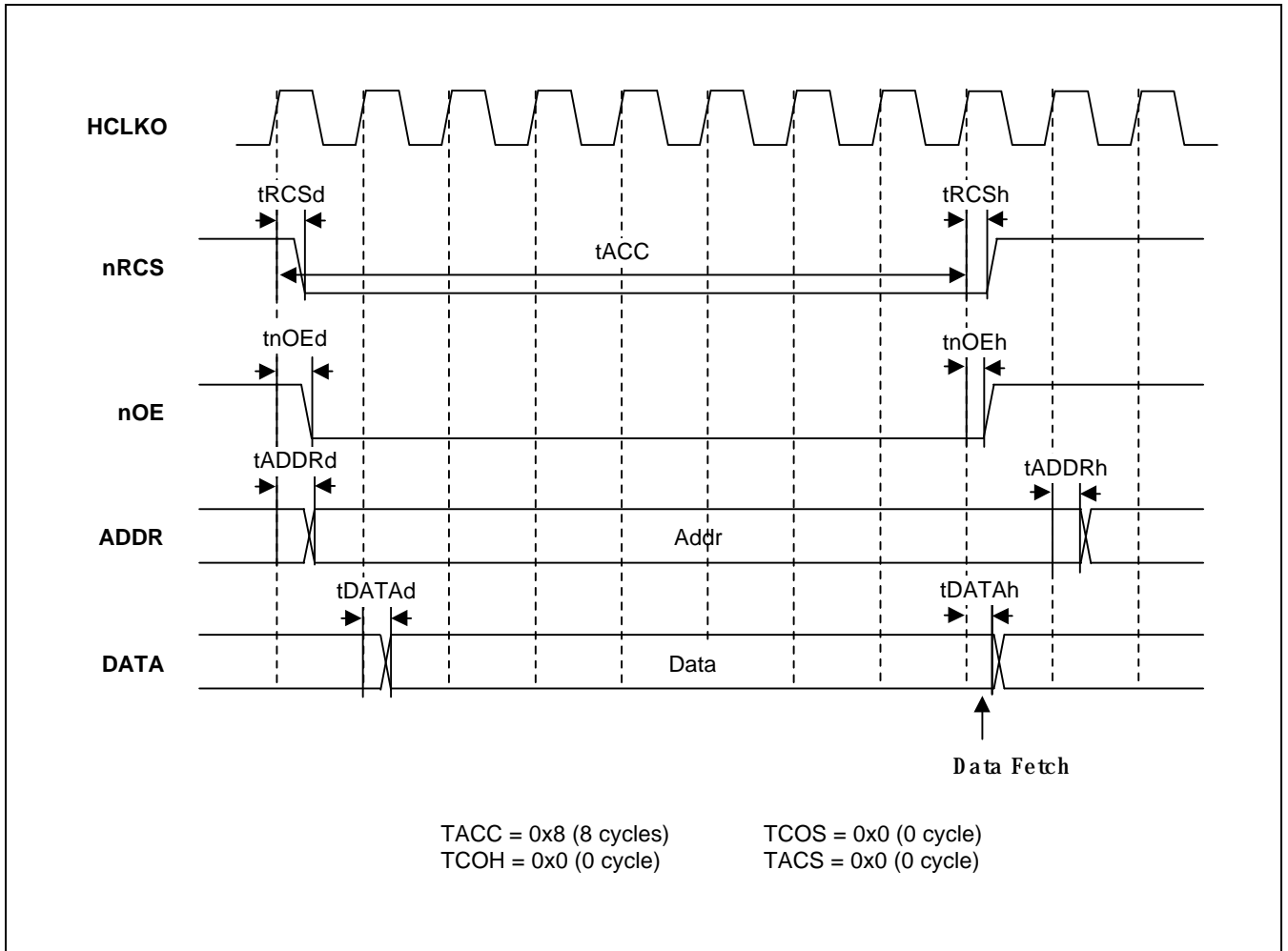

Figure 5-14. Read Timing Diagram 1

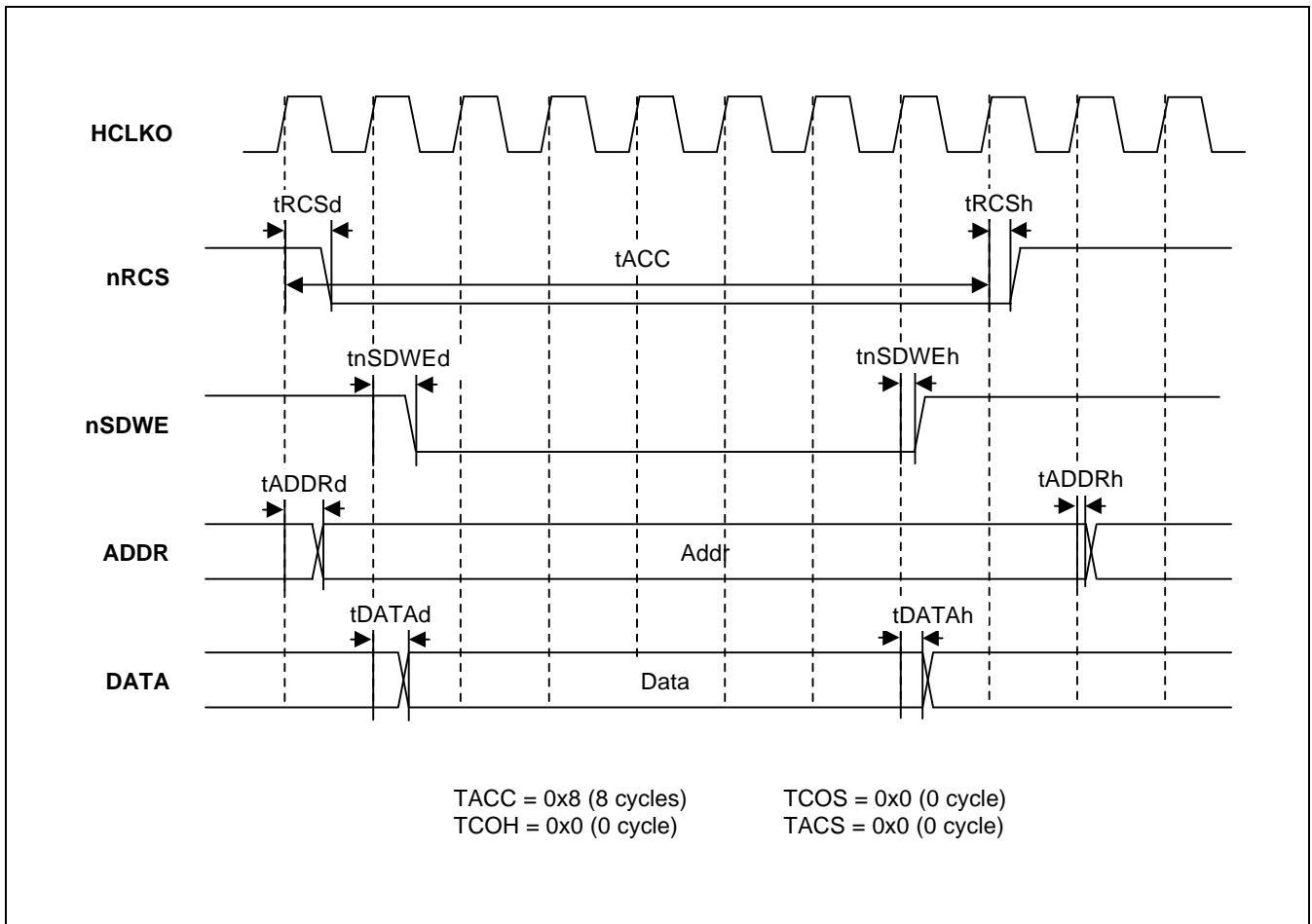

Figure 5-15. Write Timing Diagram 1

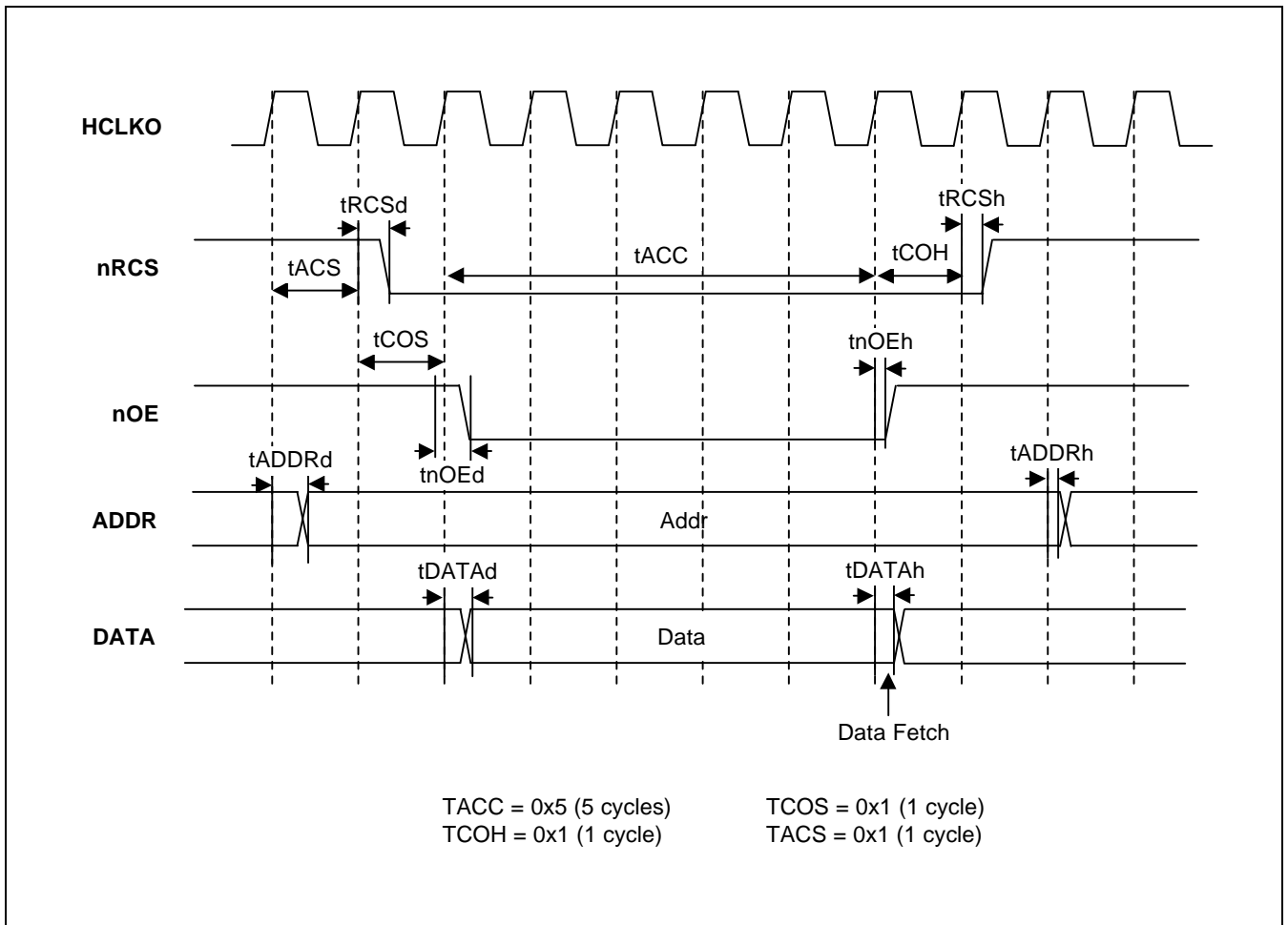

Figure 5-16. Read Timing Diagram 2

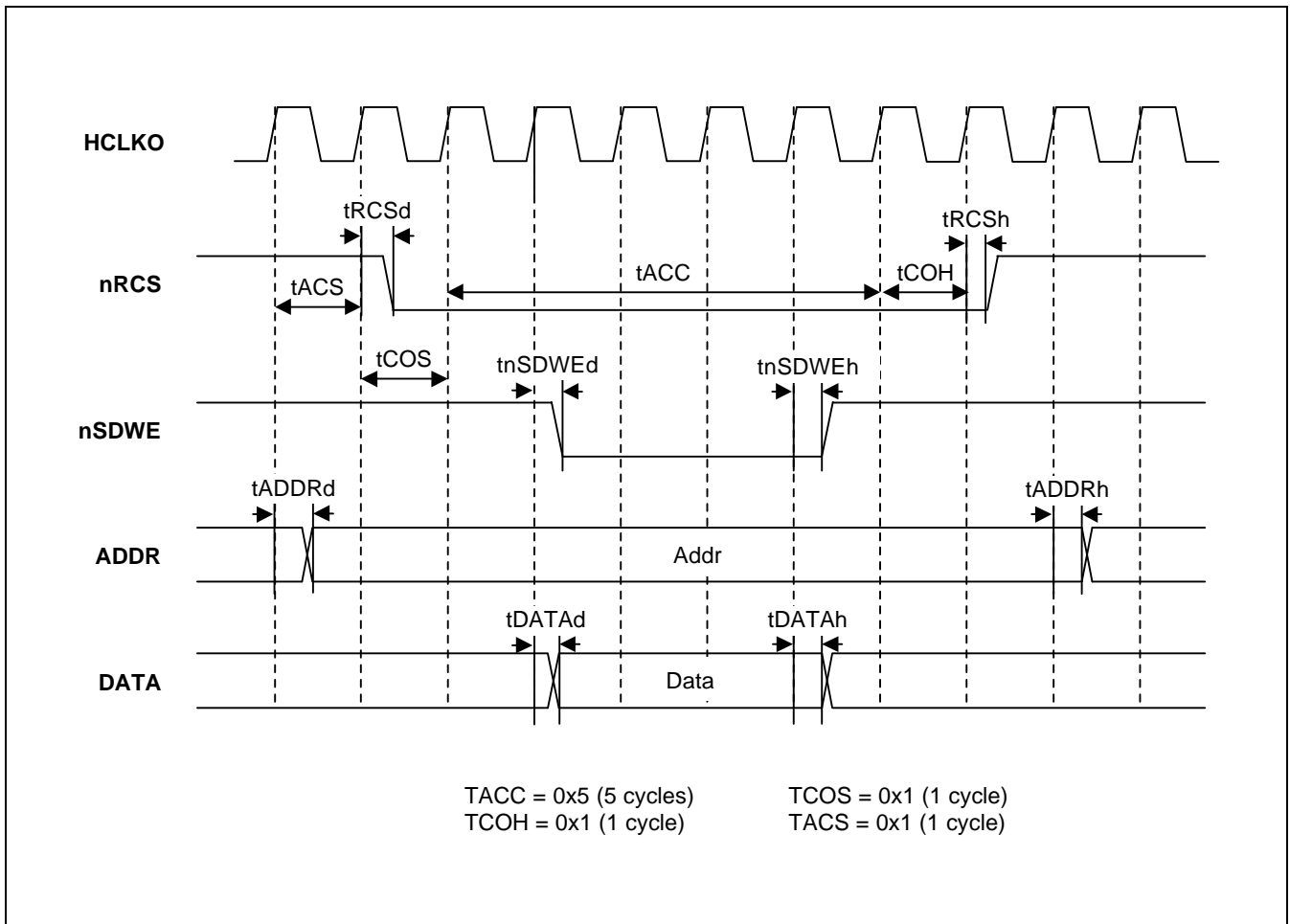

Figure 5-17. Write Timing Diagram 2

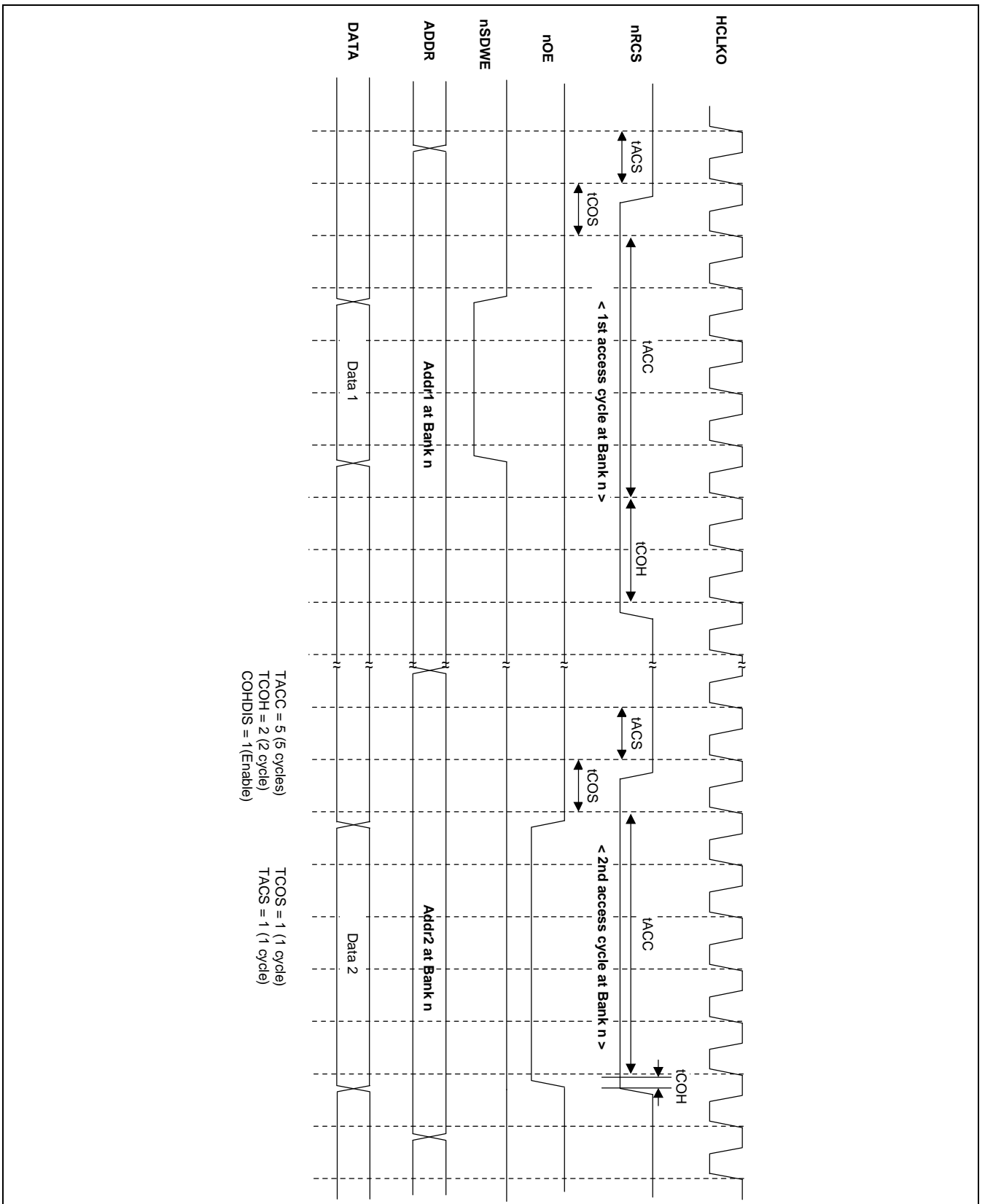

Figure 5-18. Read after Write at the Same Bank (COHDIS = 1)

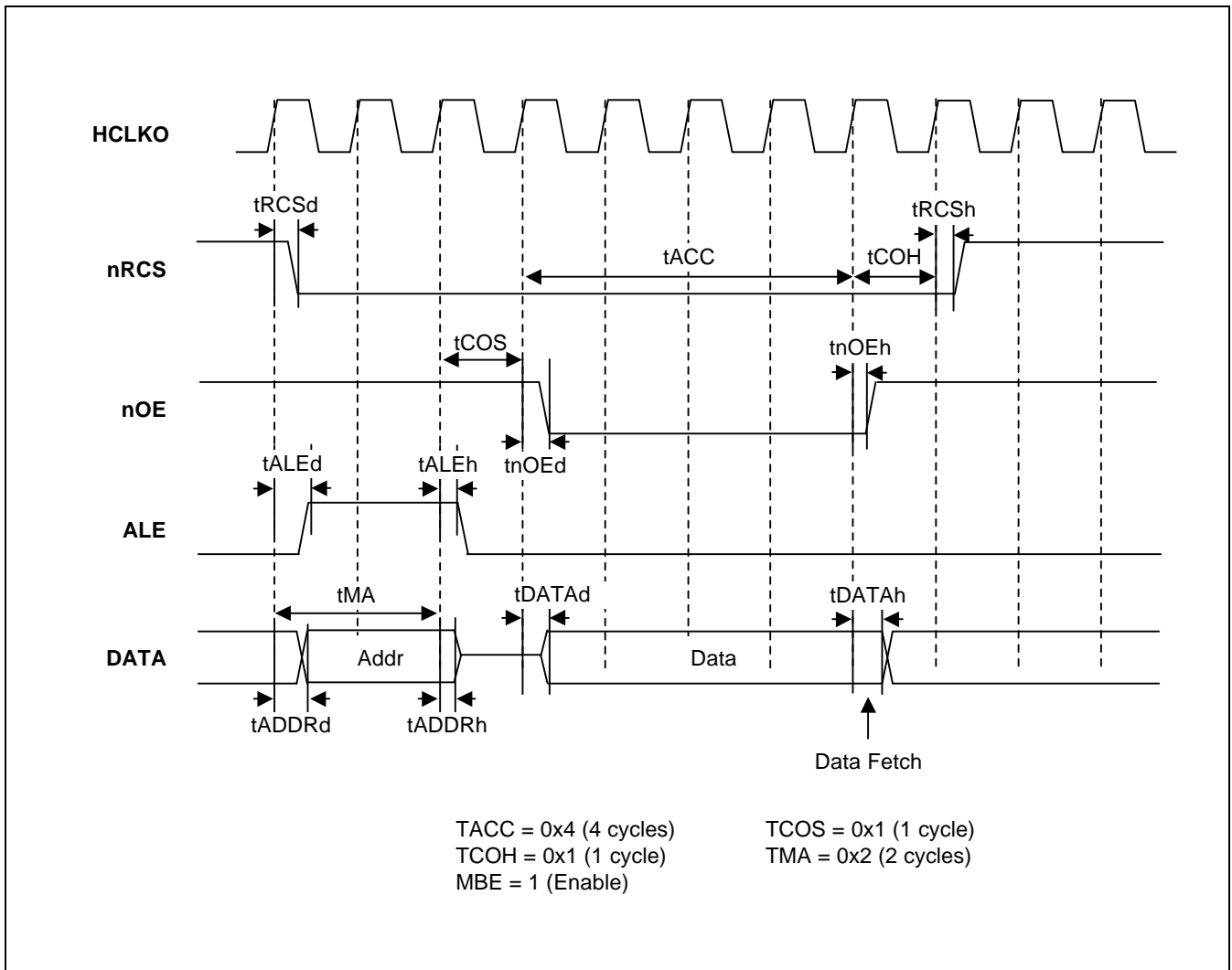

Figure 5-19. Read Timing Diagram (Muxed Bus)

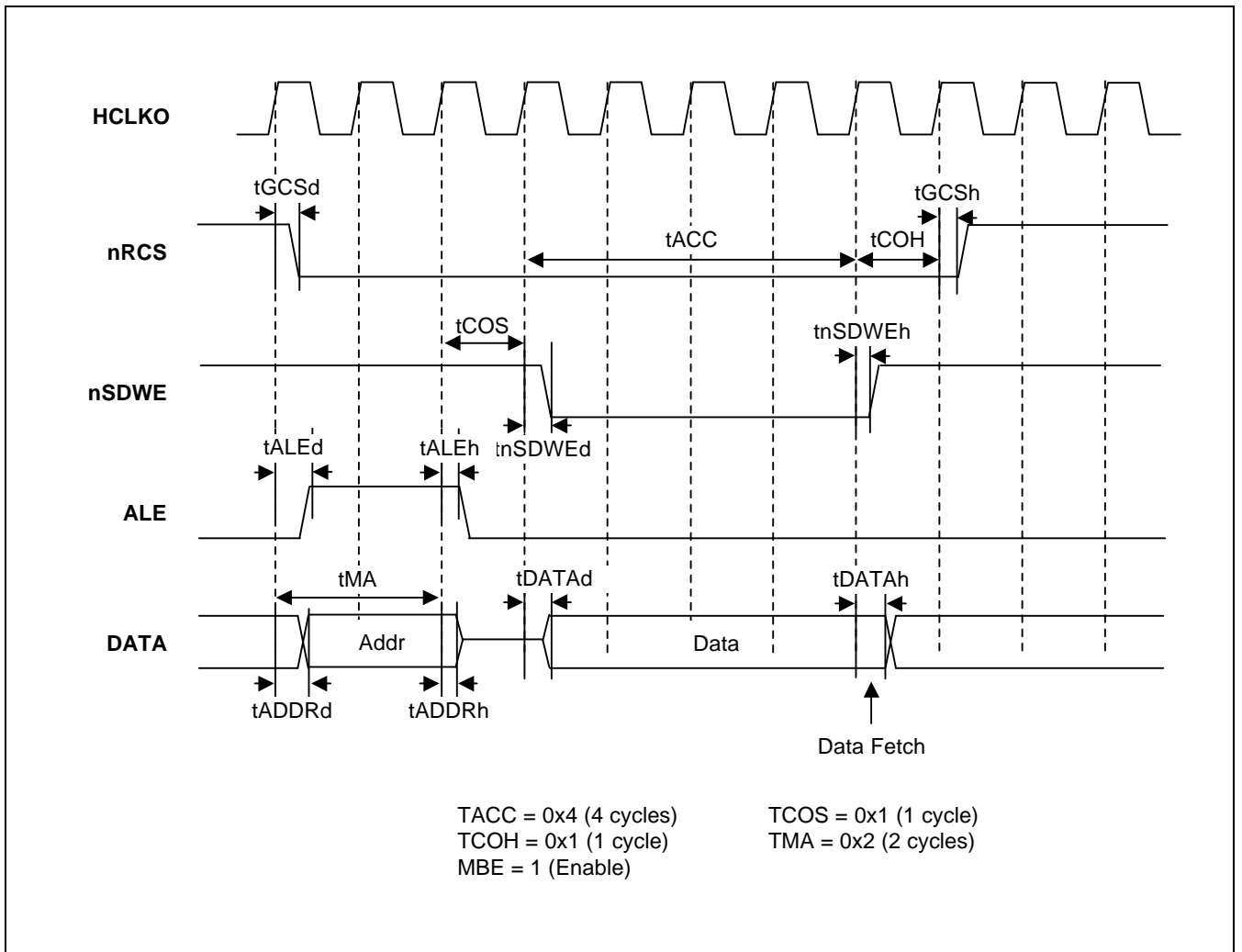

Figure 5-20. Write Timing Diagram (Muxed Bus)

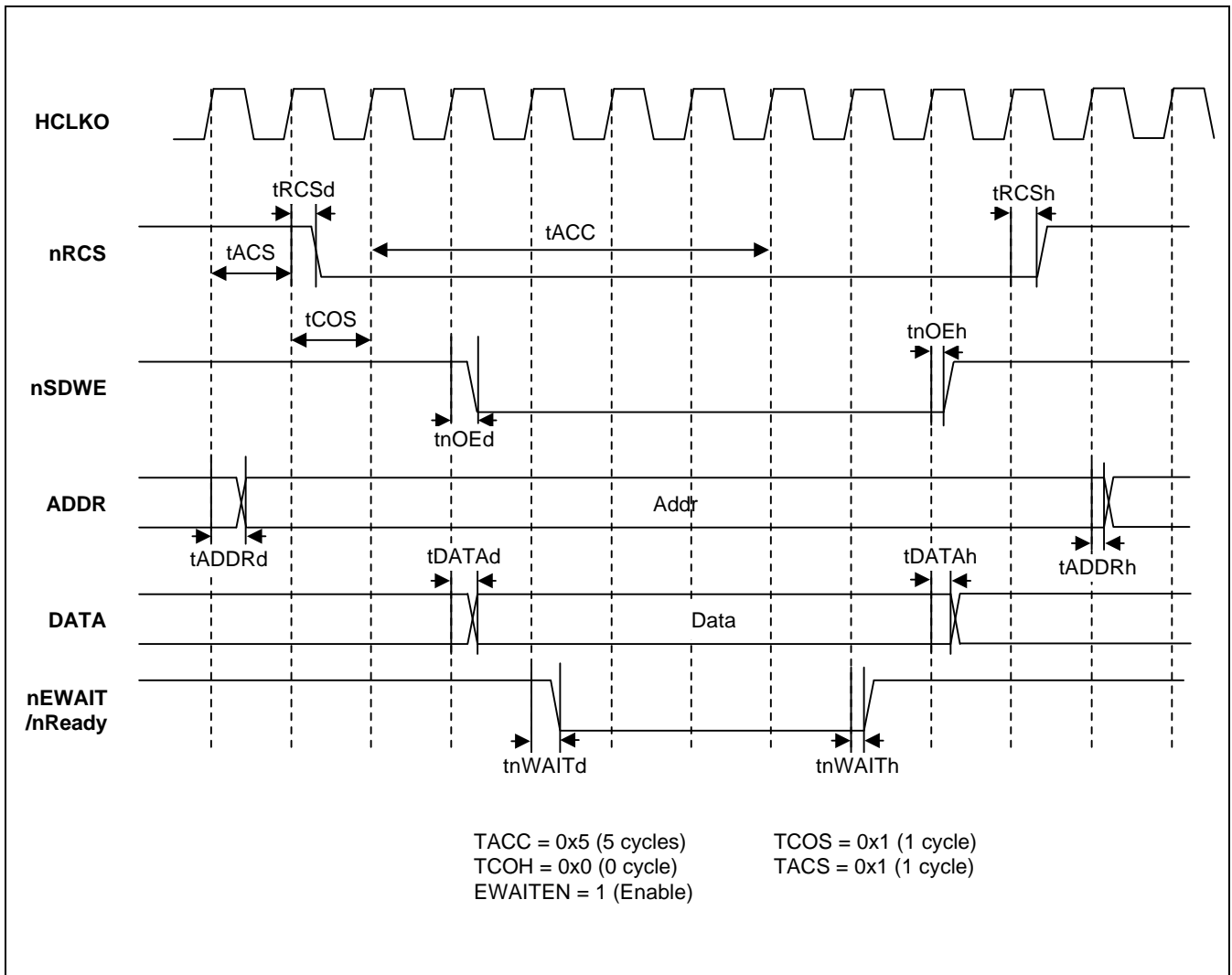

Figure 5-21. Write Timing Diagram (nWAIT)

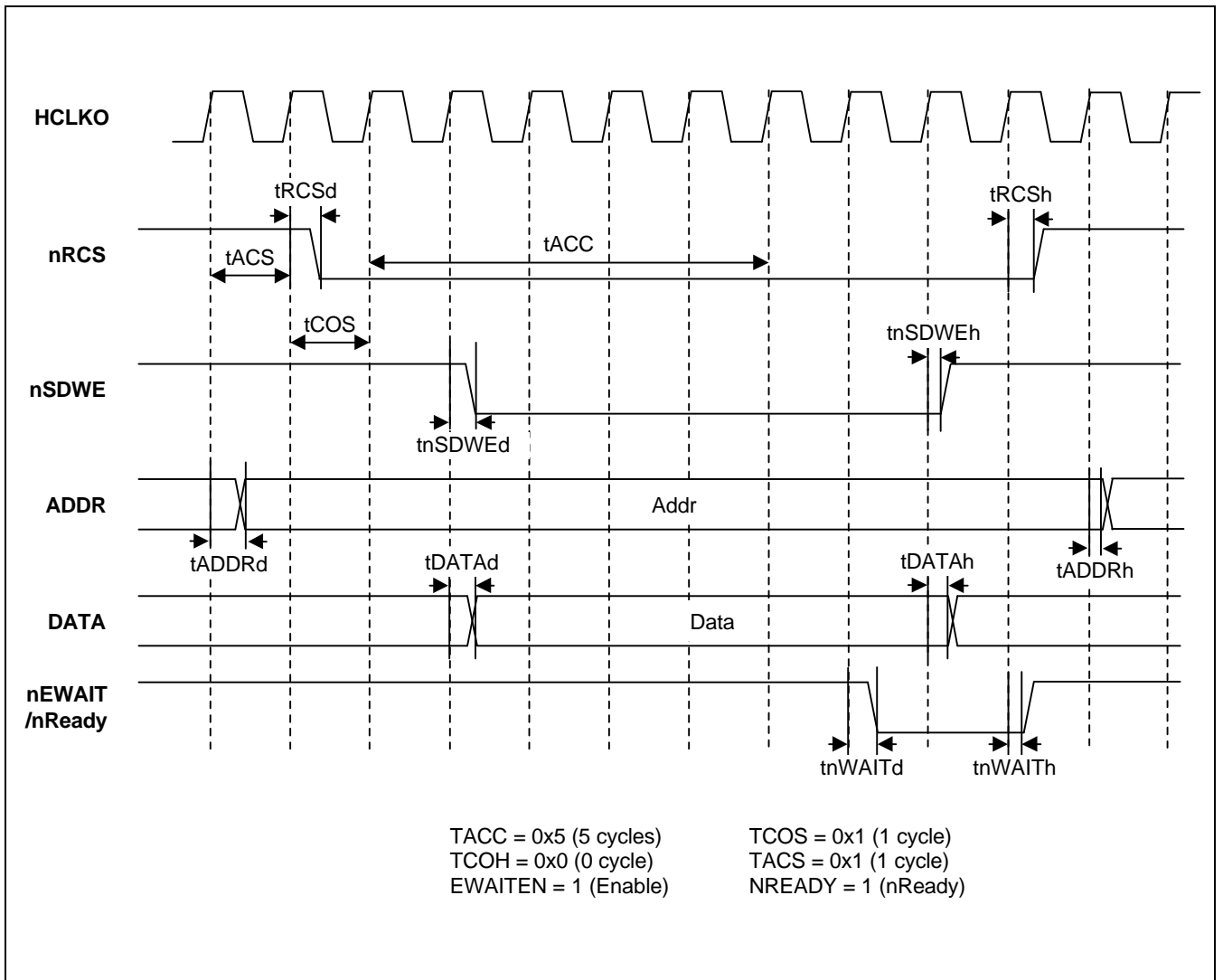

Figure 5-22. Write Timing Diagram (nREADY)

5.7 SDRAM CONTROLLER

5.7.1 FEATURES

The SDRAM controller provides the following features:

- Provides merging write buffer to improve system performance.
- Supports for 16M-bit, 64M-bit, 128M-bit and 256M-bit SDRAM devices with two or four leaves.
- Allows a direct interface to up to two banks of SDRAM.
- Each bank supports 16 or 32 bits wide and up to 128M-byte in size.
- Support byte, half-word and word transaction.
- CAS latency can be 1, 2 or 3
- Provides auto refresh and self refresh mode to sustain the contents of SDRAM memory.

5.7.2 SDRAM SIZE AND CONFIGURATION

The SDRAM controller supports a SDRAM memory ranging from 2 to 256M-byte. Table 5-19. Illustrates the supported SDRAM configurations when external bus width is 32 bits. Table 5-20. Illustrates the supported SDRAM configurations when external bus width is 16 bits.

If 16M-bit device, which has two leaves, is used, only ADDR[13] is used to select a leaf.

If SDRAM device, which has four leaves, is used, both ADDR[14] and ADDR[13] are used to select a leaf.

Only the chip select signals (nSDCS[1:0]) are to select a bank. The other SDRAM control signals are common to both banks.

Table 5-19. Supported SDRAM Configuration of 32-bit External Bus

SDRAM Technology	SDRAM Arrangement	# Banks	Address Size		Leaf Select		Total Memory Size (Byte)	
			Row	Col	ADDR[14]	ADDR[13]		
16M-bit	2M x 8	1	11	9	-	HADDR[21]	8 M	
		2					16 M	
	1M x 16	1	11	8	-	HADDR[21]	4 M	
		2					8 M	
64M-bit	8M x 8	1	12	9	HADDR[22]	HADDR[21]	32 M	
		2					64 M	
	4M x 16	1	12	8	HADDR[22]	HADDR[21]	16 M	
		2					32 M	
	2M x 32	1	11	8	HADDR[22]	HADDR[21]	8 M	
		2					16 M	
	128M-bit	16M x 8	1	12	10	HADDR[22]	HADDR[21]	64 M
			2					128 M
8M x 16		1	12	9	HADDR[22]	HADDR[21]	32 M	
		2					64 M	
4M x 32		1	12	8	HADDR[22]	HADDR[21]	16 M	
		2					32 M	
256M-bit		32M x 8	1	13	10	HADDR[22]	HADDR[21]	128 M
			2					256 M
	16M x 16	1	13	9	HADDR[22]	HADDR[21]	64 M	
		2					128 M	
	8M x 32	1	13	8	HADDR[22]	HADDR[21]	32 M	
		2					64 M	

NOTE: Banks: Number of external SDRAM memory bank used.
The controller supports up to two banks.
Leaf: Internal bank of SDRAM devices.

Table 5-20. Supported SDRAM Configuration of 16-bit External Bus

SDRAM Technology	SDRAM Arrangement	# Banks	Address Size		Leaf Select		Total Memory Size (Byte)
			Row	Col	ADDR[14]	ADDR[13]	
16M-bit	2M x 8	1	11	9	-	HADDR[20]	4 M
		2					8 M
	1M x 16	1	11	8	-	HADDR[20]	2 M
		2					4 M
64M-bit	8M x 8	1	12	9	HADDR[21]	HADDR[20]	16 M
		2					32 M
	4M x 16	1	12	8	HADDR[21]	HADDR[20]	8 M
		2					16 M
128M-bit	16M x 8	1	12	10	HADDR[21]	HADDR[20]	32 M
		2					64 M
	8M x 16	1	12	9	HADDR[21]	HADDR[20]	16 M
		2					32 M
256M-bit	32M x 8	1	13	10	HADDR[21]	HADDR[20]	64M
		2					128M
	16M x 16	1	13	9	HADDR[21]	HADDR[20]	32 M
		2					64 M

NOTE: Banks: Number of external SDRAM memory bank used.
The controller supports up to two banks
Leaf : Internal bank of SDRAM devices.

5.7.3 ADDRESS MAPPING

Table 5-21. Illustrates the AHB address bus to the SDRAM address ADDR[14:0] mapping for various memory devices when external bus width is 32 bits. Table 5-22. Illustrates the AHB address bus to the SDRAM address ADDR[14:0] mapping for various memory devices when external bus width is 16 bits.

Table 5-21. SDRAM Address Mapping of 32-bit External Bus

SDRAM Technology		Column Address (AddrOut[14:0])														
		14	13	12	11	10	9	8	7	6	5	4	3	2	1	0
16M-bit	2Mx8	*	21	*	*	AP	*	22	9	8	7	6	5	4	3	2
	1Mx16	*	21	*	*		*	*	9	8	7	6	5	4	3	2
64M-bit	8Mx8	22	21	*	*		*	24	9	8	7	6	5	4	3	2
	4Mx16	22	21	*	*		*	*	9	8	7	6	5	4	3	2
	2Mx32	22	21	*	*		*	*	9	8	7	6	5	4	3	2
128M-bit	16Mx8	22	21	*	*		25	24	9	8	7	6	5	4	3	2
	8Mx16	22	21	*	*		*	24	9	8	7	6	5	4	3	2
	4Mx32	22	21	*	*		*	*	9	8	7	6	5	4	3	2
256M-bit	32Mx8	22	21	*	*		26	25	9	8	7	6	5	4	3	2
	16Mx16	22	21	*	*		*	25	9	8	7	6	5	4	3	2
	8Mx32	22	21	*	*		*	*	9	8	7	6	5	4	3	2

SDRAM Technology		Row Address (AddrOut[14:0])														
		14	13	12	11	10	9	8	7	6	5	4	3	2	1	0
16M-bit	2Mx8	*	21	*	*	20	19	18	17	16	15	14	13	12	11	10
	1Mx16	*	21	*	*	20	19	18	17	16	15	14	13	12	11	10
64M-bit	8Mx8	22	21	*	23	20	19	18	17	16	15	14	13	12	11	10
	4Mx16	22	21	*	23	20	19	18	17	16	15	14	13	12	11	10
	2Mx32	22	21	*	*	20	19	18	17	16	15	14	13	12	11	10
128M-bit	16Mx8	22	21	*	23	20	19	18	17	16	15	14	13	12	11	10
	8Mx16	22	21	*	23	20	19	18	17	16	15	14	13	12	11	10
	4Mx32	22	21	*	23	20	19	18	17	16	15	14	13	12	11	10
256M-bit	32Mx8	22	21	24	23	20	19	18	17	16	15	14	13	12	11	10
	16Mx16	22	21	24	23	20	19	18	17	16	15	14	13	12	11	10
	8Mx32	22	21	24	23	20	19	18	17	16	15	14	13	12	11	10

Table 5-22. SDRAM address mapping of 16-bit external bus

SDRAM Technology		Column Address (AddrOut[14:0])														
		14	13	12	11	10	9	8	7	6	5	4	3	2	1	0
16M-bit	2Mx8	*	20	*	*	AP	*	21	8	7	6	5	4	3	2	1
	1Mx16	*	20	*	*		*	*	8	7	6	5	4	3	2	1
64M-bit	8Mx8	21	20	*	*		*	23	8	7	6	5	4	3	2	1
	4Mx16	21	20	*	*		*	*	8	7	6	5	4	3	2	1
128M-bit	16Mx8	21	20	*	*		24	23	8	7	6	5	4	3	2	1
	8Mx16	21	20	*	*		*	23	8	7	6	5	4	3	2	1
256M-bit	32Mx8	21	20	*	*		25	24	8	7	6	5	4	3	2	1
	16Mx16	21	20	*	*		*	24	8	7	6	5	4	3	2	1

SDRAM Technology		Row Address (AddrOut[14:0])														
		14	13	12	11	10	9	8	7	6	5	4	3	2	1	0
16M-bit	2Mx8	*	20	*	*	19	18	17	16	15	14	13	12	11	10	9
	1Mx16	*	20	*	*	19	18	17	16	15	14	13	12	11	10	9
64M-bit	8Mx8	21	20	*	22	19	18	17	16	15	14	13	12	11	10	9
	4Mx16	21	20	*	22	19	18	17	16	15	14	13	12	11	10	9
128M-bit	16Mx8	21	20	*	22	19	18	17	16	15	14	13	12	11	10	9
	8Mx16	21	20	*	22	19	18	17	16	15	14	13	12	11	10	9
256M-bit	32Mx8	21	20	23	22	19	18	17	16	15	14	13	12	11	10	9
	16Mx16	21	20	23	22	19	18	17	16	15	14	13	12	11	10	9

NOTE: AP: Auto precharge (enable and disable auto precharge function are controlled by this bit).
 At precharge command this bit controls the all bank or specified bank to be precharged.
 Shaded numbers: leaf selection bits.
 *: unused bits

5.7.4 SDRAM COMMANDS

The SDRAM controller issues specific commands to the SDRAM devices by encoding the nSDCS, nSDRAS, nSDCAS and nSDWE outputs. Table 5-23. Lists all of the SDRAM commands understood by SDRAM devices. The controller supports a subset of these commands.

Table 5-23. SDRAM commands

Command		CKE	nSDCS	nSDRAS	nSDCAS	nSDWE	BA	A10/AP	Mnemonic
Mode Register Set (MRS)		H	L	L	L	L	OP code		MRS
Refresh	Auto refresh	H	L	L	L	H	X		REF
	Self refresh	L	L	L	L	H			SREF
Row activate		H	L	L	H	H	V	X	ACT
Read	with auto precharge	H	L	H	L	H	V	H	RDA
	without auto precharge							L	RD
Write	with auto precharge	H	L	H	L	L	V	H	WRA
	without auto precharge							L	WR
Burst stop		H	L	H	H	L	X		BST
Precharge	Bank selection	H	L	L	H	L	V	L	PRE
	All banks						X	H	PALL
Active power down		L	H	X	X	X	X		APWDN
Precharge power down		L	H	X	X	X			PPWDN
No operation		H	H	H	H	H			NOP

NOTE: Shaded boxes indicate commands not supported by SDRAM controller. They are included for completeness.

X = Don't care

V = Valid value (H or L)

A10/AP = ADDR[10] /Auto Pre-charge

5.7.5 EXTERNAL DATA BUS WIDTH

The SDRAM controller supports not only 32 bit data bus, but also 16 bit data bus. External data bus width can be selected by the XW field of CFGREG.

5.7.6 MERGING WRITE BUFFER

A merging write buffer compacts the writes of all widths into quad-word, which can be efficiently transferred to the SDRAM. The merging write buffer improves the data bandwidth of write operation. The merging write buffer is comprised of write buffer 0 and write buffer 1. Each write buffer holds a quad word, which is the size of the default SDRAM data burst length. Two write buffer configuration allows a new quad word to be buffered while the contents of the other quad-word buffer are transferred to memory. These write buffers can also merge non-contiguous writes to the same quad word address.

The conditions of the write buffer flush are as follows:

- Write miss: there is a write to a SDRAM address outside the current merging quad word address
- Read hit: there is a read from the same address as the merging quad word.
- Write buffer time out: the write buffer timer reaches zero.
- The write buffer is disabled.

When a read hit, the write-back operation is completed before the requested data is read from memory to maintain data consistency between the write buffer and SDRAM memory.

5.7.7 SELF REFRESH

The SDRAM controller provides the auto refresh (REF) and self refresh (SREF) command to sustain the contents of the SDRAM. The auto refresh is issued to SDRAM periodically when refresh timer is expired. The self refresh is entered and exited by request of on-chip power manager. The self refresh is the preferred refresh mode for data retention and low power operation of SDRAM. In self refresh mode the SDRAM ignores all the input signals except CKE. The refresh addressing and timing are internally generated to reduced power consumption.

Before disabling clock of the SDRAM controller the SDRAM must be in self refresh mode to sustain the SDRAM memory data. Self refresh mode might be entered or exited by asserting or deasserting the self refresh request bit (SRreg) of the peripheral clock disable register (PCLKDIS).

It is possible to know if the SDRAM is in self refresh mode or not by reading out the SRreg bit SRack bit of the PCLKDIS register.

If the self refresh mode change is on processing, the SRack bit of the PCLKDIS is deasserted, and if the self refresh mode, change is completed, the SRack bit is asserted.

To recover from the self refresh mode to normal operation mode, the SRack bit should be checked asserted before access the SDRAM.

5.7.8 BASIC OPERATION

SDRAM initialization sequence

On power-on reset, software must initialize the SDRAM controller and each of the SDRAM connected to the controller. Refer to the SDRAM data sheet for more detailed information on the start up procedure for the SDRAM used. Typical example sequence is given below :

1. Wait 200us to allow SDRAM power and clocks to stabilize.
2. Program the INIT[1:0] of the CFGREG to **01**. This automatically issues a **PALL** command to the SDRAM.
3. Write 0xF into the refresh timer register. This provides a refresh cycle every 15 clock cycles.
4. Wait for a time period equivalent to 120 clock cycles (8 refresh cycles).
5. Program the normal operational value into the refresh timer.
6. Program the CFGREG to their normal operation values.
7. Program the INIT[1:0] to **10**. This automatically issues a **MRS** command to the SDRAM.
8. Program the INIT[1:0] to **00**. The controller enters the normal mode.
9. Program the CMDREG and WBTOREG to their normal operation values.
10. The SDRAM is now ready for normal operation.

5.7.9 SDRAM SPECIAL REGISTERS

The address and reset value of the special registers in the SDRAM controller summarized in Table 5-24.

Table 5-24. SDRAM Special Registers

Name	Address	Description	Reset value
CFGREG	0xF0020000	Configuration register	0x00099F0C
CMDREG	0xF0020004	Command register	0x00000000
REFREG	0xF0020008	Refresh timer register	0x00000020
WBTOREG	0xF002000C	Write buffer time-out register	0x00000000

5.3.9.1 Configuration Register

The configuration register is 32-bit read/write (some bits are read only) register. This register contains SDRAM control parameters such as external bus width, memory type, and various timing parameters.

Table 5-25. SDRAM Configuration Register

Registers	Address	R/W	Description	Reset value
CFGREG	0xF0020000	R/W	SDRAM Configuration register	0x00099F0C

Table 5-25 SDRAM Configuration Register (Continue)

Reg0	Bit	Description	R/W	Default value
XW	[0]	External data bus Width 0 = external bus width is 32 bit. 1 = external bus width is 16 bit.	R/W	0
AP	[1]	Auto Pre-charge control for SDRAM accesses 0 = Auto pre-charge 1 = No auto pre-charge	R/W	0
CL	[3:2]	CAS Latency 00 = Reserved 01 = CL: 1 cycle 10 = CL: 2 cycles 11 = CL: 3 cycles	R/W	11
D1[1:0]	[5:4]	SDRAM device Density of bank 1 00 = 16M-bit SDRAM memory devices. 01 = 64M-bit SDRAM memory devices. 10 = 128M-bit SDRAM memory devices. 11 = 256M-bit SDRAM memory devices.	R/W	00
D0[1:0]	[7:6]	SDRAM device Density of bank 0 00 = 16M-bit SDRAM memory devices. 01 = 64M-bit SDRAM memory devices. 10 = 128M-bit SDRAM memory devices. 11 = 256M-bit SDRAM memory devices.	R/W	00
RP	[9:8]	Row Pre-charge time 00 = RP: 1 cycle 01 = RP: 2 cycles 10 = RP: 3 cycles 11 = RP: 4 cycles	R/W	11
RCD	[11:10]	RAS to CAS delay 00 = RCD: 1 cycle 01 = RCD: 2 cycles 10 = RCD: 3 cycles 11 = RCD: 4 cycles	R/W	11
RC	[15:12]	Row Cycle 0000 = RC: 1 cycles 0001 = RC: 2 cycles ... 1110 = RC: 15 cycles 1111 = RC: 16 cycles	R/W	1001
RAS	[19:16]	Row Active time 0000 = RAS: 1 cycles 0001 = RAS: 2 cycles ... 1110 = RAS: 15 cycles 1111 = RAS: 16 cycles	R/W	1001
	[31:20]	Reserved	—	

NOTES:

- Software should not write to configuration register when the SDRAM engine is busy. The SDRAM engine status bit, BUSY in command register, can be used to check if the control engine is idle.
- We recommend that the auto pre-charge should be disable by asserting "1" on the AP of Reg0 when the page hit ratio is more than 50%.

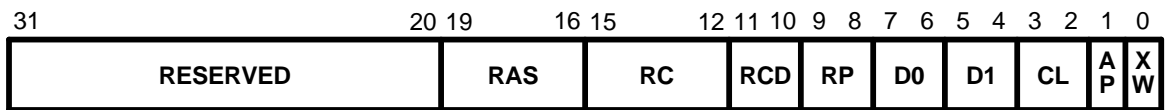

[0] eXternal data bus Width : XW

0 = external bus width is 32 bit , 1 = external bus width is 16 bit

[1] Auto Pre-charge control for SDRAM accesses: AP

0 = Auto pre-charge , 1 = No auto pre-charge

[3:2] CAS Latency: CL

00 = Reserved 01 = 1 cycles 10 = 2 cycles 11 = 3 cycles

[5:4] SDRAM device Density of bank 1: D1

00 = 16 Mbit SDRAM memory devices.
 01 = 64 Mbit SDRAM memory devices.
 10 = 128 Mbit SDRAM memory devices.
 11 = 256 Mbit SDRAM memory devices.

[7:6] SDRAM device Density of bank 0: D0

00 = 16 Mbit SDRAM memory devices.
 01 = 64 Mbit SDRAM memory devices.
 10 = 128 Mbit SDRAM memory devices.
 11 = 256 Mbit SDRAM memory devices.

[9:8] Row Pre-charge time: RP

00 = 1 cycle 01 = 2 cycles 10 = 3 cycles 11 = 4 cycles

[11:10] RAS to CAS delay: RCD

00 = 1 cycle 01 = 2 cycles 10 = 3 cycles 11 = 4 cycles

[15:12] Row Cycle: RC

0000 = 1 cycle	0001 = 2 cycles	0010 = 3 cycles	0011 = 4 cycles
0100 = 5 cycles	0101 = 6 cycles	0110 = 7 cycles	0111 = 8 cycles
1000 = 9 cycles	1001 = 10 cycles	1010 = 11 cycle	1011 = 12 cycles
1100 = 13cycles	1101 = 14 cycles	1110 = 15 cycles	1111 = 16 cycles

[19:16] Row Active time: RAS

0000 = 1 cycle	0001 = 2 cycles	0010 = 3 cycles	0011 = 4 cycles
0100 = 5 cycles	0101 = 6 cycles	0110 = 7 cycles	0111 = 8 cycles
1000 = 9 cycles	1001 = 10 cycles	1010 = 11 cycle	1011 = 12 cycles
1100 = 13cycles	1101 = 14 cycles	1110 = 15 cycles	1111 = 16 cycles

[31:20] Reserved

Figure 5-23. SDRAM Configuration Register

5.7.9.2 Command Register

The configuration register 1 is 32-bit read/write (some bits are read only) register. The SDRAM initialization command, write buffer operation can be controlled by this register.

Table 5-26. SDRAM Command Register

Registers	Address	R/W	Description	Reset value
CMDREG	0xF0020004	R/W	SDRAM command register	0x00000000

CMDREG	Bit	Description	R/W	Default value
INIT	[1:0]	Control bits for SDRAM device initialization 00 = Normal operation 01 = Automatically issue a PALL to the SDRAM 10 = Automatically issue a MRS to the SDRAM 11 = reserved	R/W	00
WBUF	[2]	Write buffer enable 0 = Disable merging write buffer 1 = Enable merging write buffer NOTE: Disabling the write buffer will flush any stored value(s) to the external SDRAM memory	R/W	0
BUSY	[3]	SDRAM controller status bit 0 = SDRAM controller is idle 1 = SDRAM controller is busy	R	0
	[31:4]	Reserved		

NOTE: WBUF field of configuration register is a read-only bit if write buffers are not included in an AHB interface sub-block

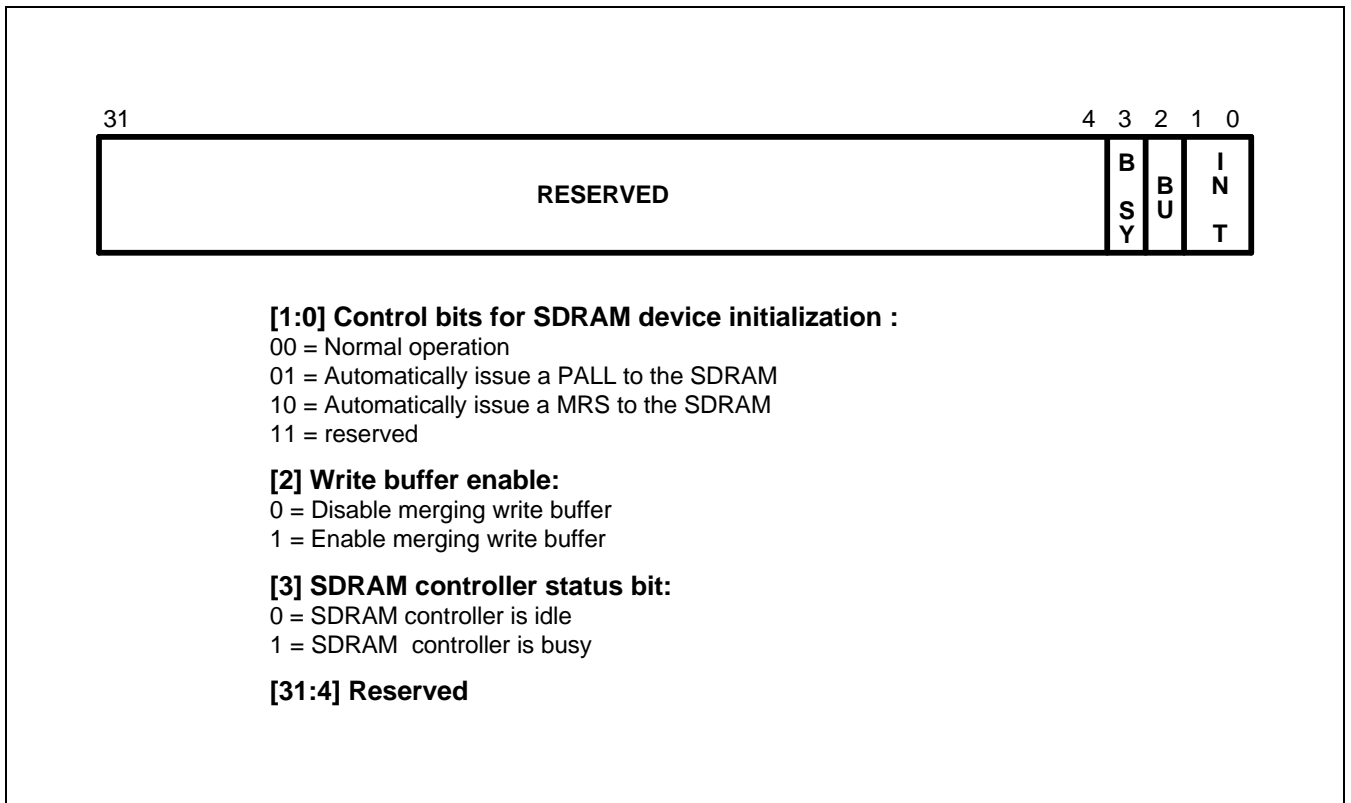

Figure 5-24. SDRAM Command Register

5.7.9.3 Refresh Timer Register

The Refresh timer register is 32-bit read/write (some bits are read only) register. This register sets the SDRAM refresh cycle. The refresh timer register is programmed with the number of system bus clock that should be counted between SDRAM refresh cycles.

Table 5-27. SDRAM Refresh Timer Register

Registers	Address	R/W	Description	Reset value
REFREG	0xF0020008	R/W	Refresh timer register	0x00000020

REFREG	Bit	Description	R/W	Default value
REFCYC	[15:0]	SDRAM refresh cycle	R/W	0x00000020
	[31:16]	Reserved		

For example, for common refresh period of 15.6us, and a system bus clock frequency of 66MHz:

$$15.6 \times 10^{-6} \times 66 \times 10^6 = 1029$$

The refresh timer is set to 64 on reset. To ensure a refresh interval of less than 15.6us after reset, The minimum frequency of system bus clock allowed is:

$$64 / (15.6 \times 10^{-6}) = 4.3 \text{ MHz}$$

The refresh register should be written to as early as possible in the system start-up procedure, especially when clock frequency is very low.

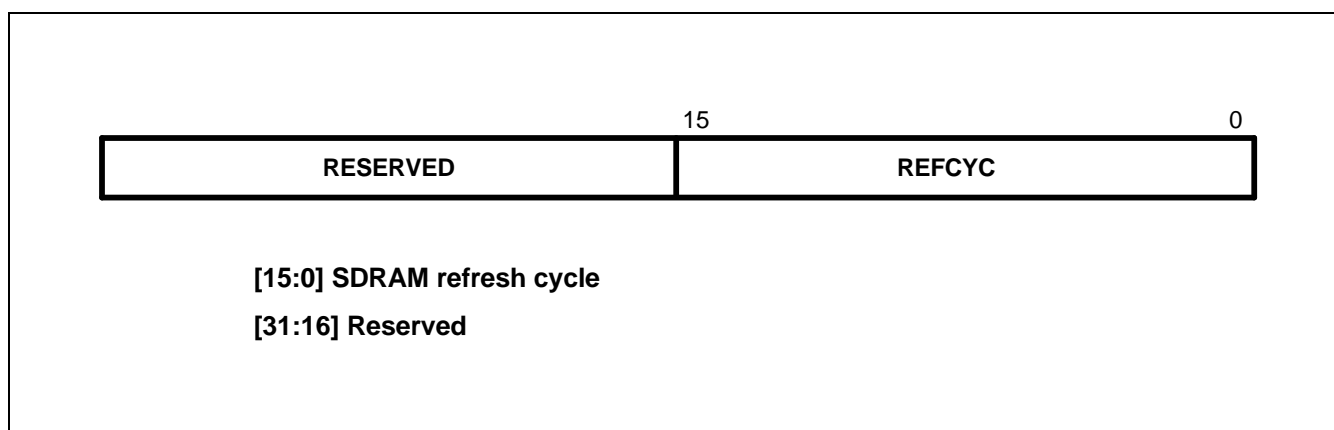

Figure 5-25. SDRAM Refresh Timer Register

5.7.9.4 Write Buffer Time-out Register

The write buffer time-out register works with the merging write buffer (if write buffer is enabled). This 16-bit read/write field of register sets the cycles for a forced flush of the write buffer.

Table 5-28. SDRAM Write Buffer Time-out Register

Registers	Address	R/W	Description	Reset value
WBTOREG	0xF002000C	R/W	Write buffer time-out register	0x00000000

WBTOREG	Bit	Description	R/W	Default value
WBTO	[15:0]	Write buffer time-out delay time	R/W	0x00000000
	[31:16]	Reserved	—	

A write to a merging write buffer loads the value in the timeout register into the time-out down counter of the buffer. When the time-out counter reaches 0 the merging write buffer contents is written (flushed) to the external memory. The down counter is clocked by system bus clock. Storing a value of 0 in the timeout register disables the write buffer timeout function.

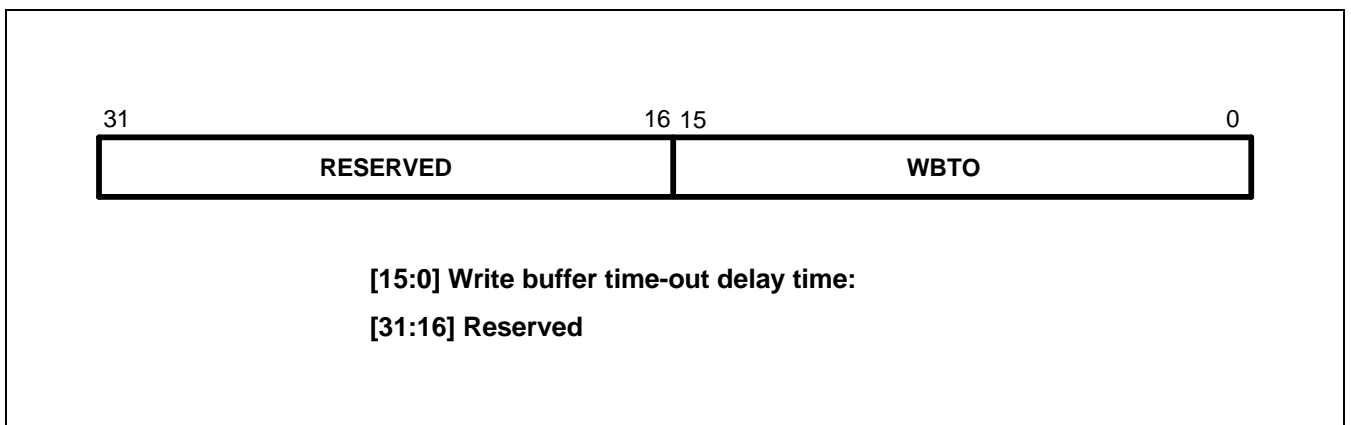

Figure 5-26. SDRAM Write Buffer Time-out Register

5.7.10 SDRAM CONTROLLER TIMING

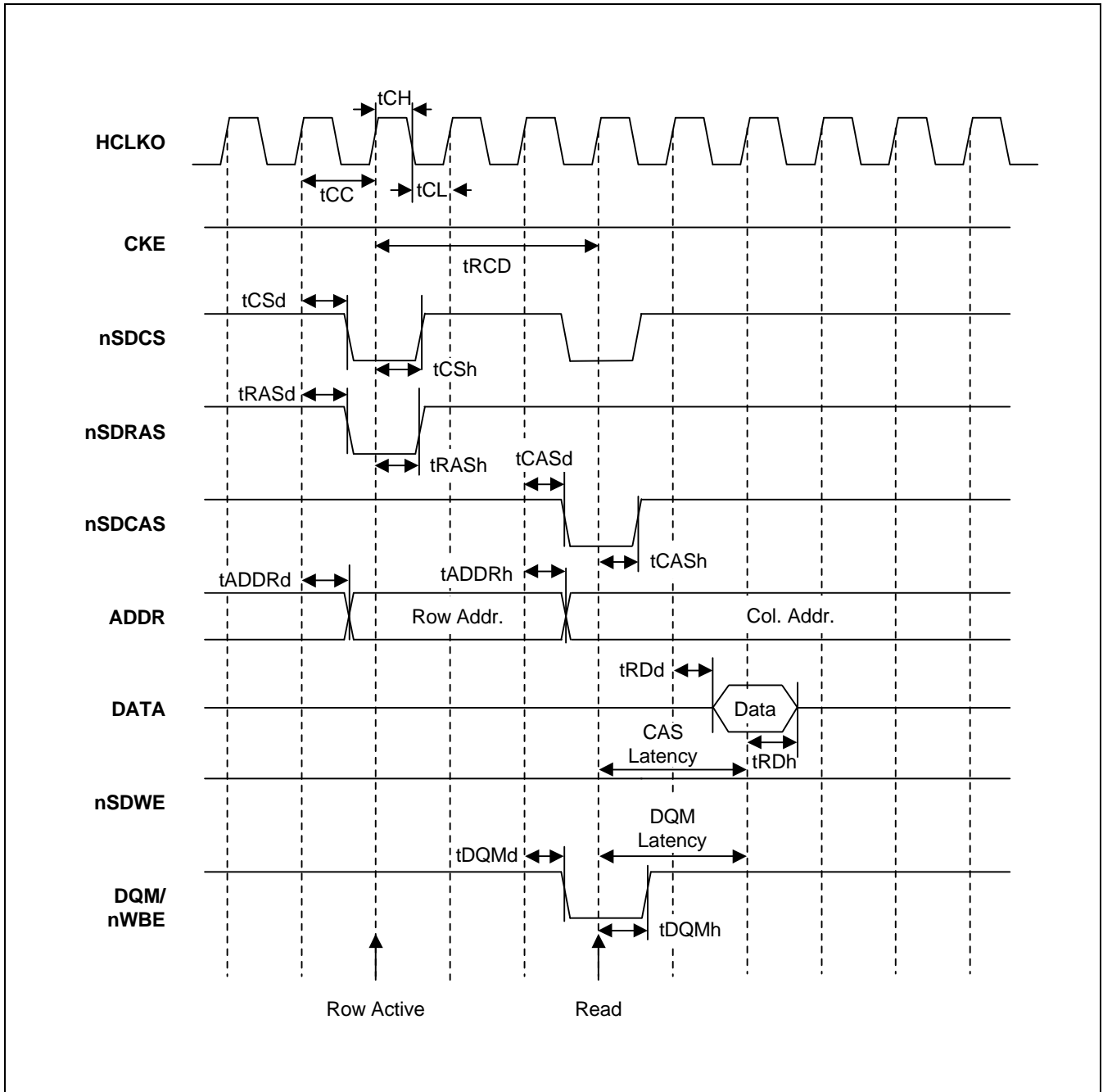

Figure 5-27. Single Read Operation (CAS Latency=2)

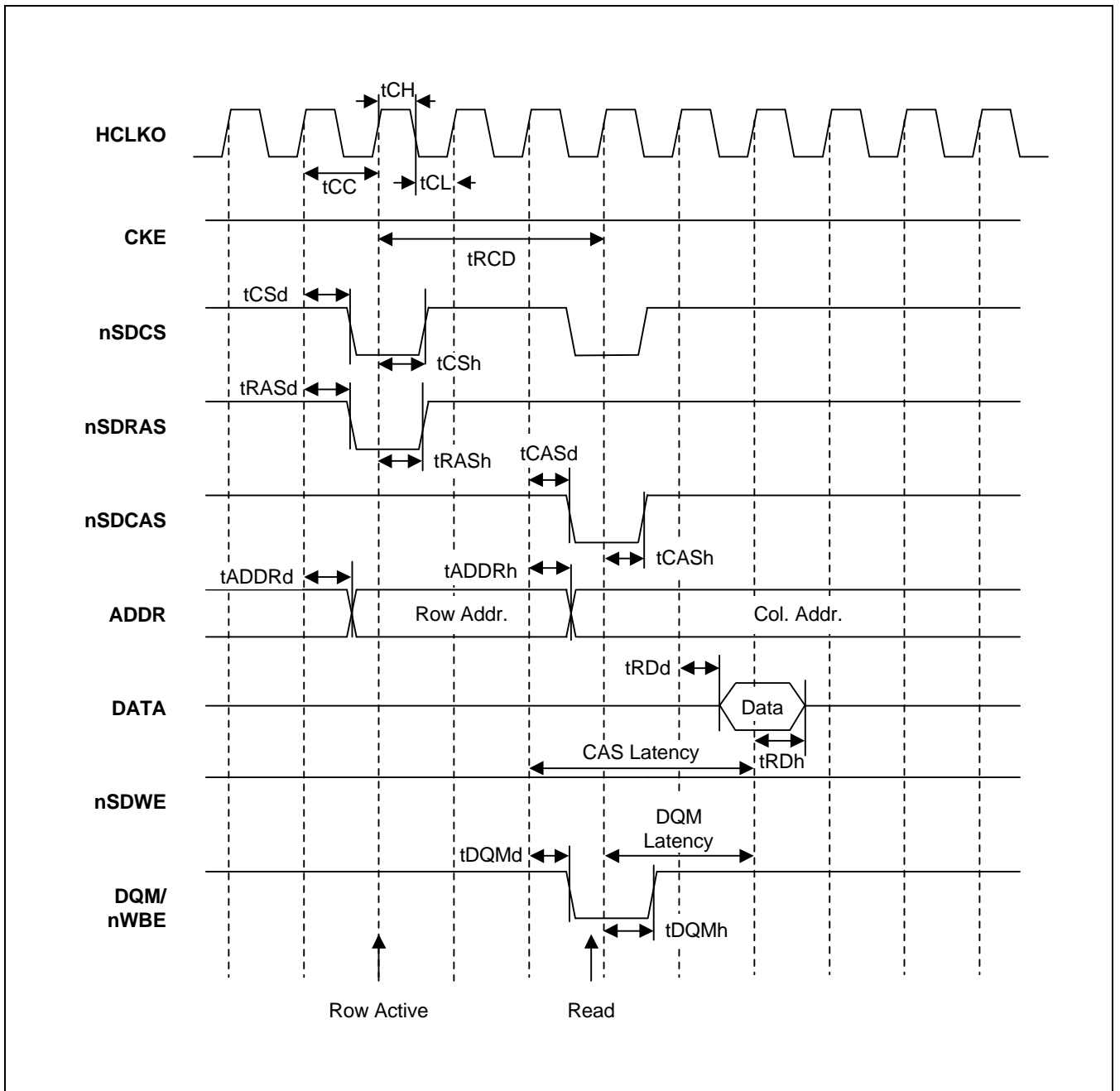

Figure 5-28. Single Read Operation (CAS Latency=3)

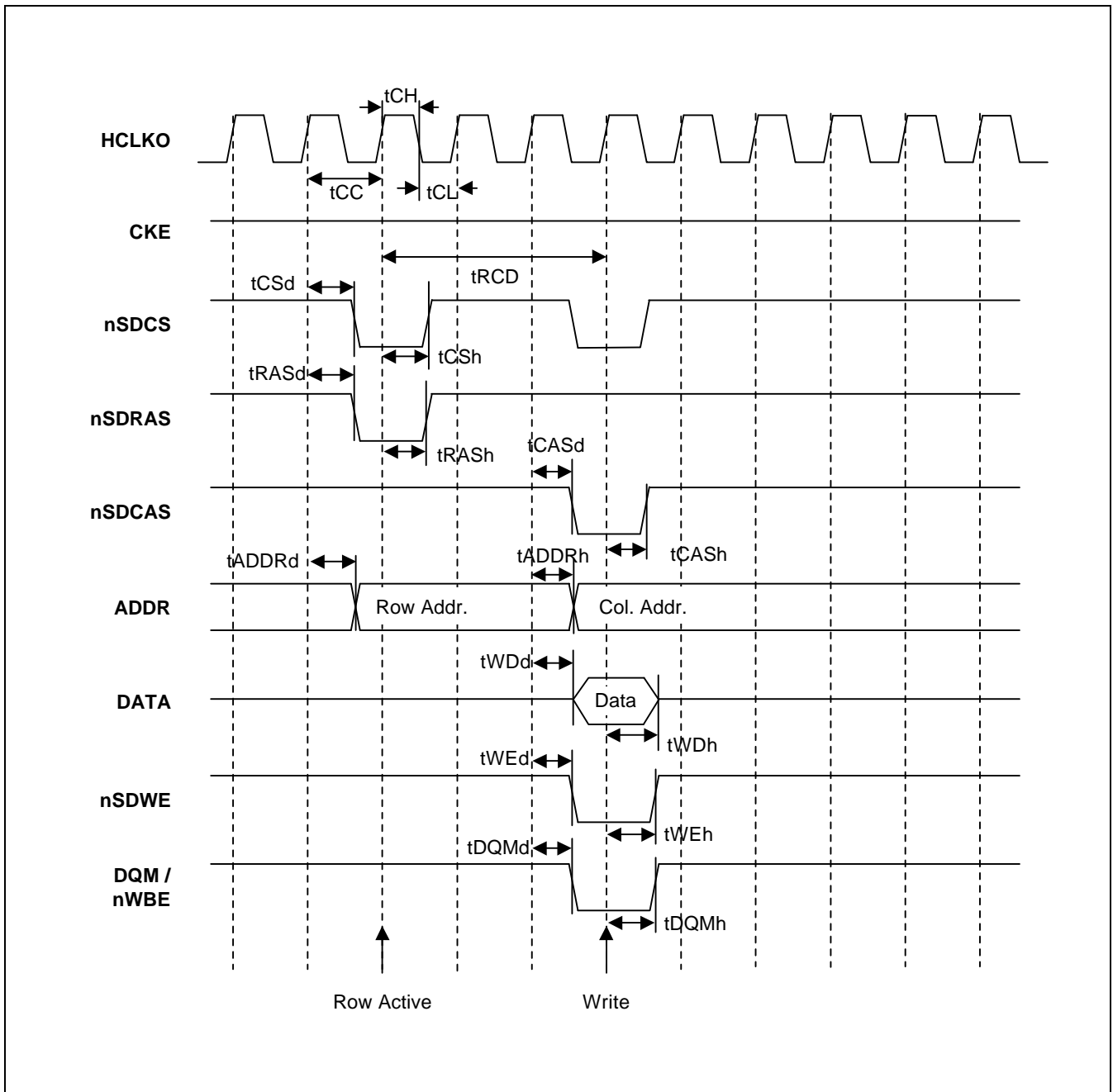

Figure 5-29. Single Write Operation

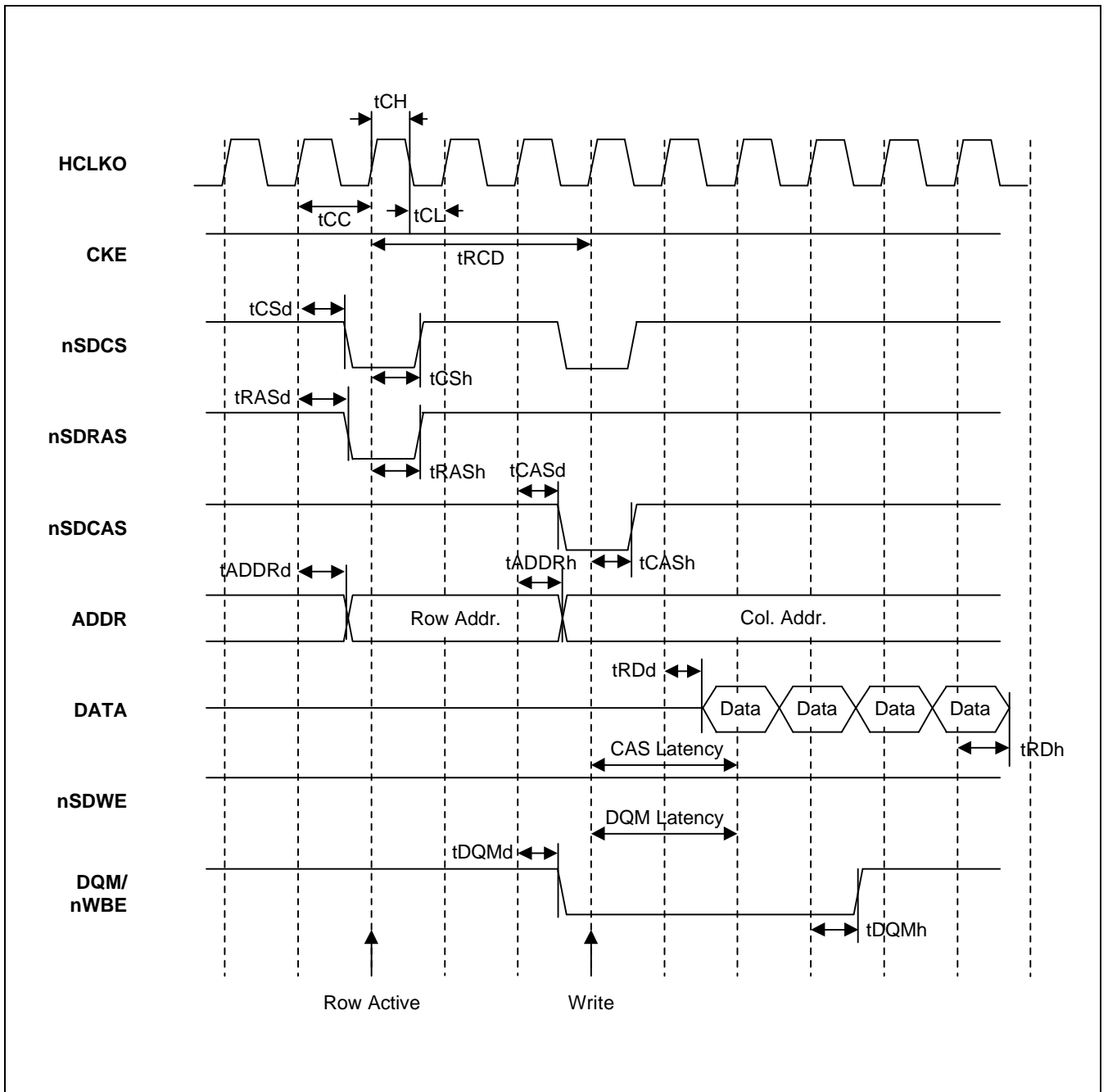

Figure 5-30. Burst Read Operation (CAS Latency = 2)

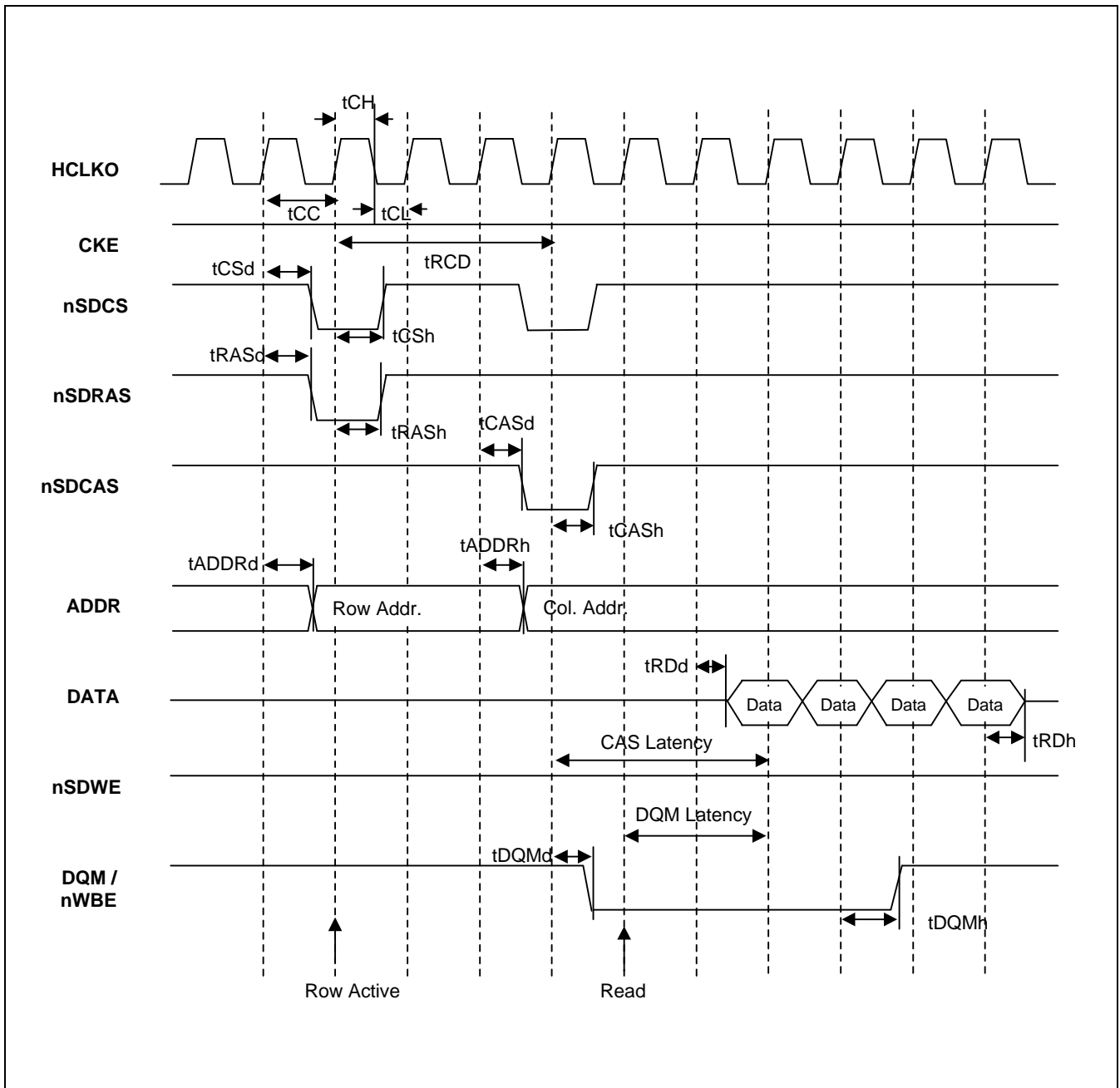

Figure 5-31. Burst Read Operation (CAS Latency = 3)

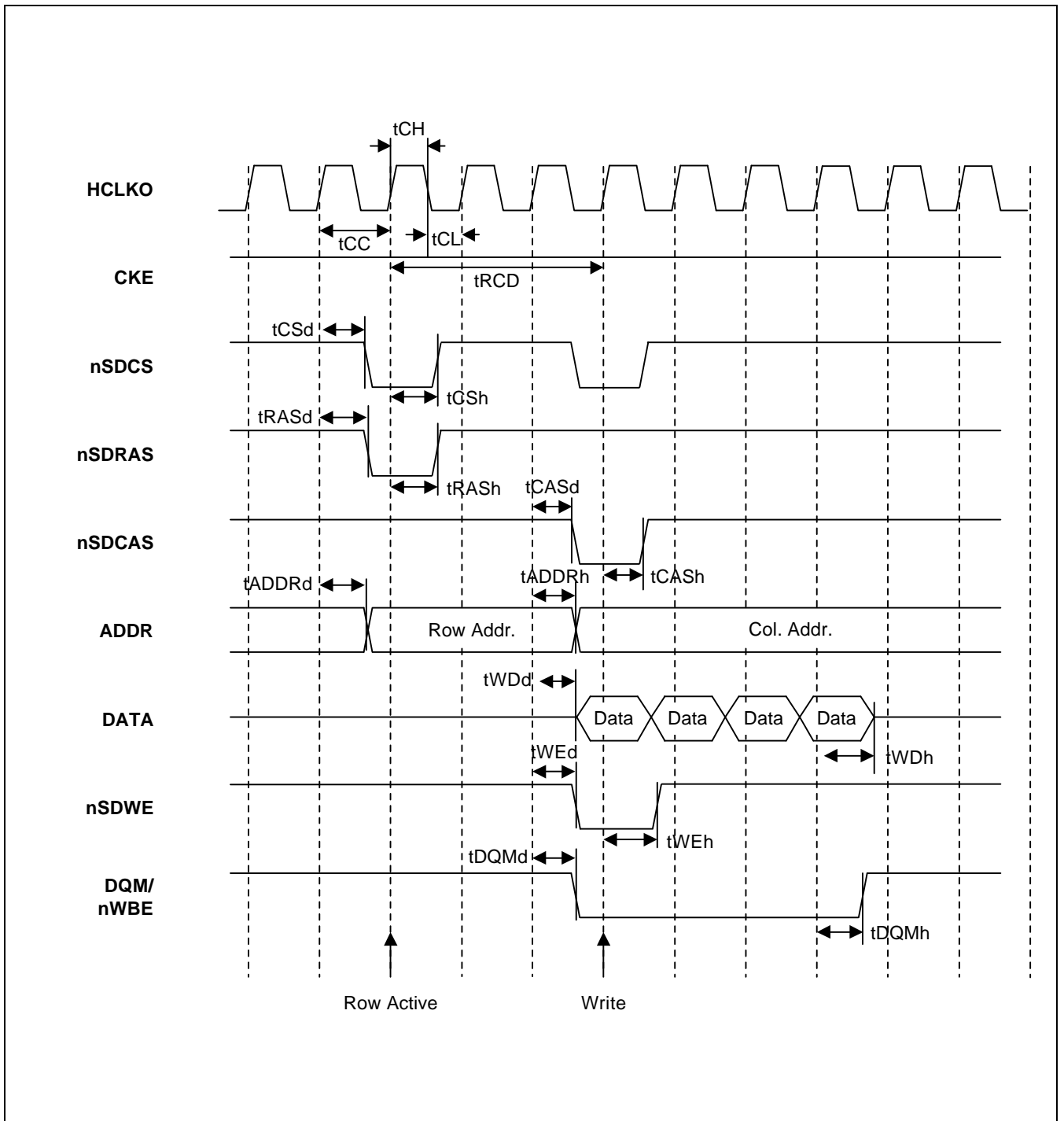

Figure 5-32. Burst Write Operation

NOTES

6 I²C CONTROLLER

6.1 OVERVIEW

The S3C2501X has internal I²C (or IIC) controller. It requires only two bus lines, a serial data line (SDA) and a serial clock lines (SCL). When the I²C is free, both lines are high level. It is connected to the same I²C. And the number of IC is limited only by the maximum bus capacitance of 400 pF.

6.2 FEATURES

- Supports only single master mode.
- Supports 8-bit, bi-directional, serial data transfers.
- Supports 7-bit addressing.

Figure 6-1 shows a block diagram of the S3C2501X I²C controller

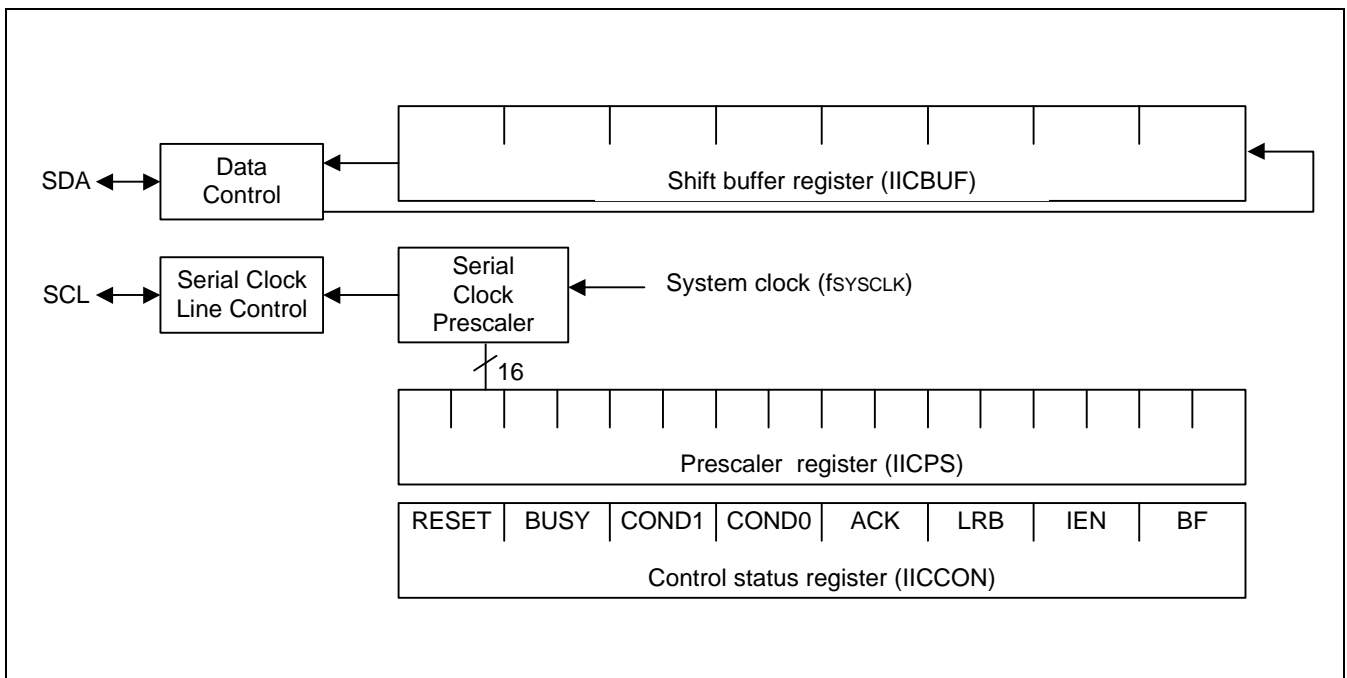

Figure 6-1. I²C Block Diagram

6.3 FUNCTIONAL DESCRIPTION

The S3C2501X I²C controller is the master of the serial I²C. Using a prescaler register, the user can program the serial clock frequency that is supplied to the I²C controller. The serial clock frequency is calculated as follows:

Serial clock frequency = $f_{\text{SYSCLK}} / (16 \times (\text{prescaler register value} + 1) + 3)$
, where f_{SYSCLK} is the system clock frequency.

6.4 I²C CONCEPTS

6.4.1 BASIC OPERATION

The I²C has two wires, a serial data line (SDL) and a serial clock line (SCL), to carry information between the IC's connected to the bus. Each IC is recognized by a unique address and can operate as either a transmitter or receiver, depending on the function of the specific IC's.

The I²C is a multi-master bus. This means that more than ICs which are capable of controlling the bus can be connected to it. Data transfers proceed as follows:

Case 1: A master IC wants to send data to another IC (slave):

1. Master addresses slave
2. Master sends data to the slave (master is transmitter, slave is receiver)
3. Master terminates the data transfer

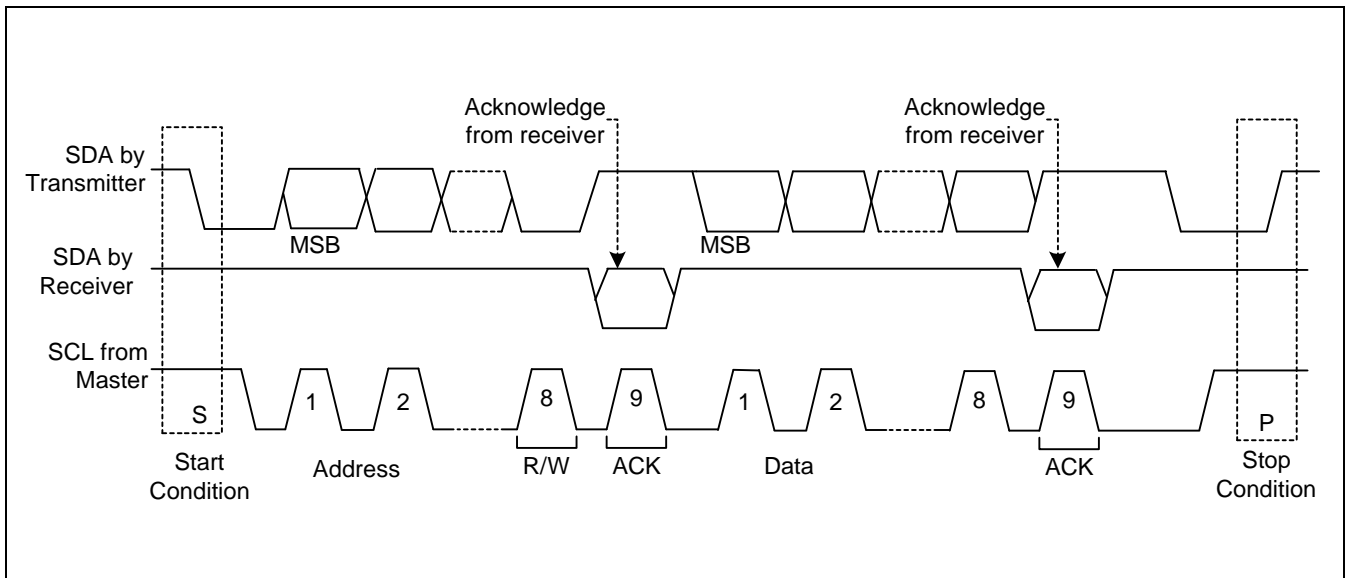

Figure 6-2. Master Transmitter and Slave Receiver

Case 2: A master IC wants to receive information from another IC (slave):

1. Master addresses slave
2. Master receives data from the slave (master is receiver, slave is transmitter)
3. Master terminates the data transfer

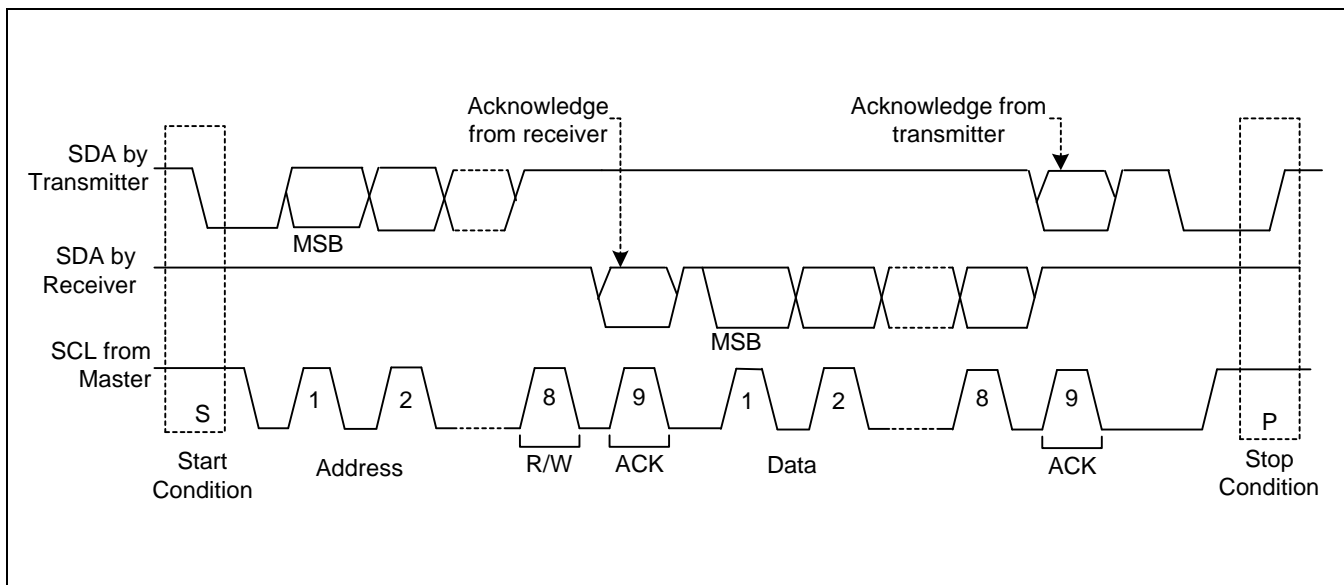

Figure 6-3. Master Receiver and Slave Transmitter

Even in this case, the master IC generates the timing and terminates the transfer.

The master IC is always responsible for generating the clock signals on the I²C. Bus clock signals from a master can only be altered by 1) a slow slave IC which "stretches" the signal by temporarily holding the clock line Low, or 2) by another master IC during arbitration.

6.4.2 GENERAL CHARACTERISTICS

Both SDA and SCL are bi-directional lines which are connected to a positive supply voltage through a pull-up resistor.

When the I²C is free, the SDA and SCL lines are both high level. The output stages of I²C interfaces connected to the bus have an open-drain or open-collector to perform the wired-AND function. Data on the I²C can be transferred at a rate up to 100 Kbits/s. The number of interfaces that can be connected to the bus is solely dependent on the limiting bus capacitance of 400 pF.

6.4.3 BIT TRANSFERS

Due to the variety of different IC's (CMOS, NMOS, and I²L, for example) which can be connected to the I²C, the levels of logic zero (low) and logic one (high) are not fixed and depend on the associated level of V_{DD} . One clock pulse is generated for each data bit that is transferred.

6.4.4 DATA VALIDITY

The data on the SDA line must be stable during the high period of the clock. The high or low state of the data line can only change when clock signal on the SCL line is low.

6.4.5 START AND STOP CONDITIONS

Start and stop conditions are always generated by the master. The bus is considered to be busy after the start condition is generated. The bus is considered to be free again when a brief time interval has elapsed following the stop condition.

- Start condition: a High-to-Low transition of the SDA line while SCL is high.
- Stop condition: a Low-to-High transition of the SDA line while SCL is high.

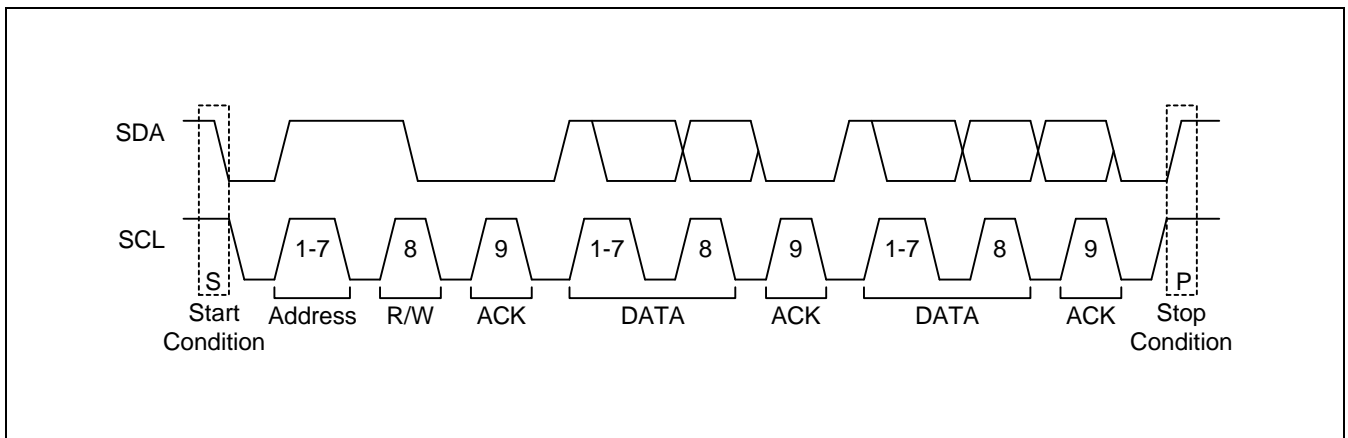

Figure 6-4. Start and Stop Conditions

6.4.6 DATA TRANSFER OPERATIONS

6.4.6.1 Data Byte Format

Every data byte that is put on the SDA line must be 8 bits long. The number of bytes that can be transmitted per transfer is unlimited. Each byte must be followed by an acknowledge bit. Data is transferred MSB-first.

If the receiver cannot receive another complete byte of data until it has performed some other functions (such as servicing an internal interrupt), it can hold the clock line SCL low to force the transmitter into a wait state. The data transfer then continues when the receiver is ready for another byte of data and releases the SCL line.

6.4.6.2 Acknowledge Procedure

Data transfer with acknowledge is obligatory. The acknowledge-related clock pulses must be generated by the bus master. The transmitter releases the SDA line (High) during the acknowledge clock pulse.

The receiver must pull down the SDA line during the acknowledge pulse so that it remains stable low during the high period of this clock pulse.

Usually, a receiver which has been addressed is obliged to generate an acknowledge after each byte is received. When a slave receiver does not acknowledge from the slave address, the slave must leave the data line high. The master can then generate a stop condition to abort the transfer.

If a slave receiver acknowledges the slave address, but later in the transfer cannot receive any more data bytes, the master must again abort the transfer. This is indicated by the slave not generating the acknowledge on the first byte to follow. The slave leaves the data line high and the master generates the stop condition.

If a master receiver is involved in a transfer, it must signal the end of data to the slave transmitter by not generating an acknowledge on the last byte that was clocked out of the slave. The slave transmitter must then release the data line to let the master generate the stop condition.

6.4.6.3 Data Transfer Format

Data transfers uses the format shown in Figure 6-5. After the start condition has been generated, a 7-bit slave address is sent. The eighth bit is a data direction bit (R/W). A "0" direction bit indicates a transmission (Write) and a "1" indicates a request for data (Read).

A data transfer is always terminated by a stop condition which is generated by the master. However, if a master still wishes to communicate on the bus, it can generate another start condition and address another slaves without first generating a stop condition. This feature supports the use of various combinations of read/write formats for data transfers.

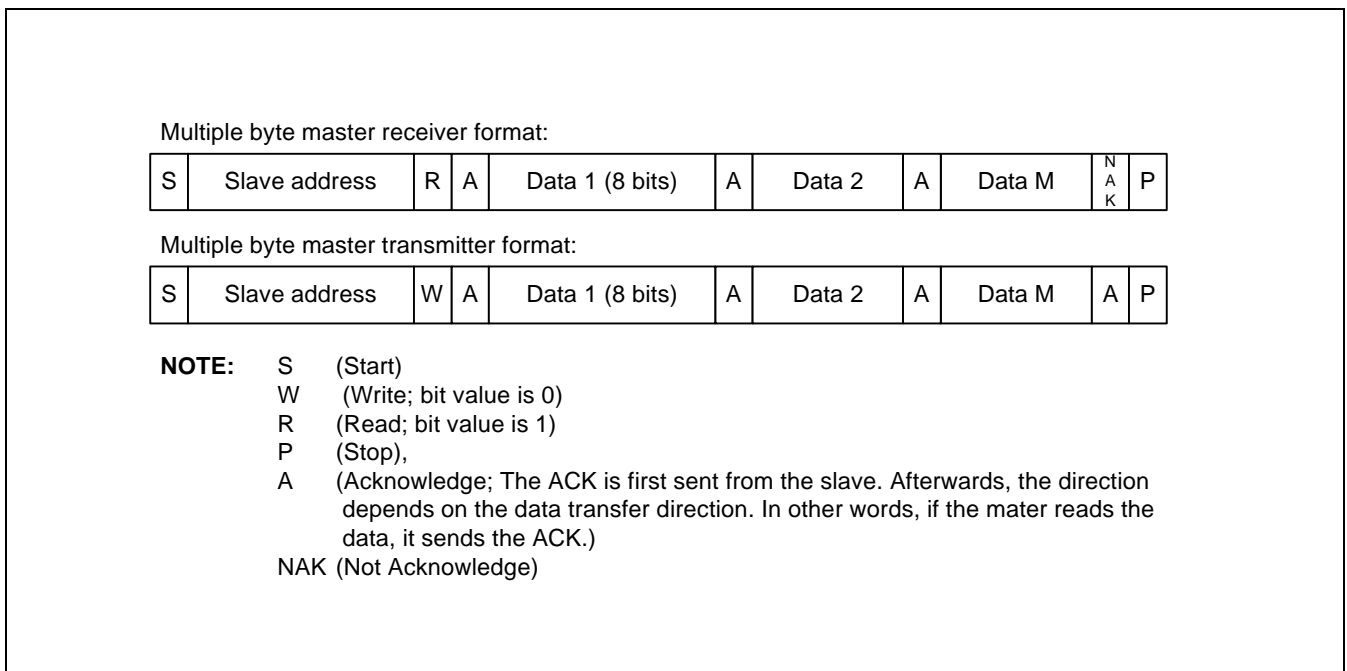

Figure 6-5. Data Transfer Format

6.4.6.4 I²C Addressing

The addressing procedure for the I²C is such that the first byte after the start condition determines which slave the master will select. Usually, this first byte immediately follows the start procedure.

An exception is the "general call" address which can address all ICs simultaneously. When this address is used, all ICs should, in theory, respond with an acknowledge. However, ICs can also be made to ignore this address. The second byte of the general call address then defines the action to be taken.

6.4.6.5 Definition of Bits in the First Data Byte

The first seven bits of the first data byte make up the slave address. The eighth bit is the LSB, or direction bit, which determines the direction (R/W) of the message.

When an address is sent, each IC on the bus compares the first 7 bits received following start condition with its own address. If the addresses match, the IC considers itself addressed by the master as a slave receiver or a slave transmitter.

6.5 I²C SPECIAL REGISTERS

The I²C controller has three special registers: a control status register (IICCON), a prescaler register (IICPS), and a shift buffer register (IICBUF).

6.5.1 CONTROL STATUS REGISTER (IICCON)

The control status register for the I²C, IICCON, is described in Table 6-2.

Table 6-1. Control Status Register (IICCON)

Register	Address	R/W	Description	Rest Value
IICCON	0xF00F0000	R/W	Control status register	0x00000000

Table 6-2. IICCON Register Description

Bit Number	Bit Name	Description
[0]	Buffer flag (BF)	The BF bit is set when the buffer is empty in transmit mode or when the buffer is full in receive mode. To clear the buffer, you write a "0" to this bit. The BF bit is cleared automatically whenever the IICBUF register is written or read.
[1]	Interrupt enable (IEN)	Setting the interrupt enable bit to "1" enables the I ² C interrupt. An interrupt is generated if BF bit set to 1.
[2]	Last received bit (LRB)	The LRB bit is read only. It holds the value of the last received bit over the I ² C. Normally, this bit will be the value of the slave acknowledgement. To check for slave acknowledgement, you test the LRB.
[3]	Acknowledge enable (ACK)	The ACK bit is normally set to "1". This causes the I ² C controller to send an acknowledge automatically after each byte. This bit must be "0" when the I ² C controller is operating in receiver mode and requires no further data to be received from the slave transmitter. This causes a negative acknowledge on the I ² C, which halts further reception from the slave device.
[5:4]	COND1, COND0	These bits control the generation of the start, stop, and repeat start conditions: "00" = no effect, "01" = start, "10" = stop, and "11" = repeat start. When start condition, BF bit should be set simultaneously. When repeated start condition, ACK bit should be set simultaneously
[6]	Bus busy (BUSY)	This bit is a read-only flag that indicates when the I ² C is in use. A "1" indicates that the bus is busy. This bit is set or cleared by a start or stop condition, respectively.
[7]	Reset	If "1" is written to the reset bit, the I ² C controller is reset to its initial state.
[31:8]	Reserved	Not applicable.

6.5.2 SHIFT BUFFER REGISTER (IICBUF)

Table 6-3. IICBUF Register

Register	Address	R/W	Description	Rest Value
IICBUF	0xF00F0004	R/W	Shift buffer register	Undefined

Bit Number	Bit Name	Description
[7:0]	Data	This data field acts as serial shift register and read buffer for interfacing to the I ² C. All read and write operations to/from the I ² C are done via this register. The IICBUF register is a combination of a shift register and a data buffer. 8-bit parallel data is always written to the shift register, and read from the data buffer. I ² C data is always shifted in or out of the shift register.
[31:8]	Reserved	Not applicable.

6.5.3 PRESCALER REGISTER (IICPS)

Table 6-4. IICPS Register

Register	Address	R/W	Description	Rest Value
IICPS	0xF00F0008	R/W	Prescaler register	0x00000000

Bit Number	Bit Name	Description
[15:0]	Prescaler value	This prescaler value is used to generate the serial I ² C clock. The system clock is divided by $(16 \times (\text{prescaler value} + 1) + 3)$ to make the serial I ² C clock. If the prescaler value is zero, the system clock is when divided by 19 to make the serial I ² C clock. Therefore, when I ² C is used to 100kbit/s in the standard mode, the prescaler value must be changed.
[31:16]	Reserved	Not applicable.

6.5.4 PRESCALER COUNTER REGISTER (IICNT)

Table 6-5. IICNT Register

Register	Address	R/W	Description	Rest Value
IICNT	0xF00F000C	R/W	Prescaler counter register	0x00000000

Bit Number	Bit Name	Description
[15:0]	Counter value	This 16-bit value is the value of the prescaler counter. It is read (in test mode only) to check the counter's current value.
[31:16]	Reserved	Not applicable.

6.5.5 INTERRUPT PENDING REGISTER (IICPND)

Table 6-6. IICPND Register

Register	Address	R/W	Description	Rest Value
IICPND	0xF00F0010	R/W	Interrupt pending register	0x00000000

Bit Number	Bit Name	Description
[0]	Interrupt pending value	This bit is set when the interrupt is generated and cleared when the same value of interrupt pending bit is rewritten.
[31:1]	Reserved	Not applicable.

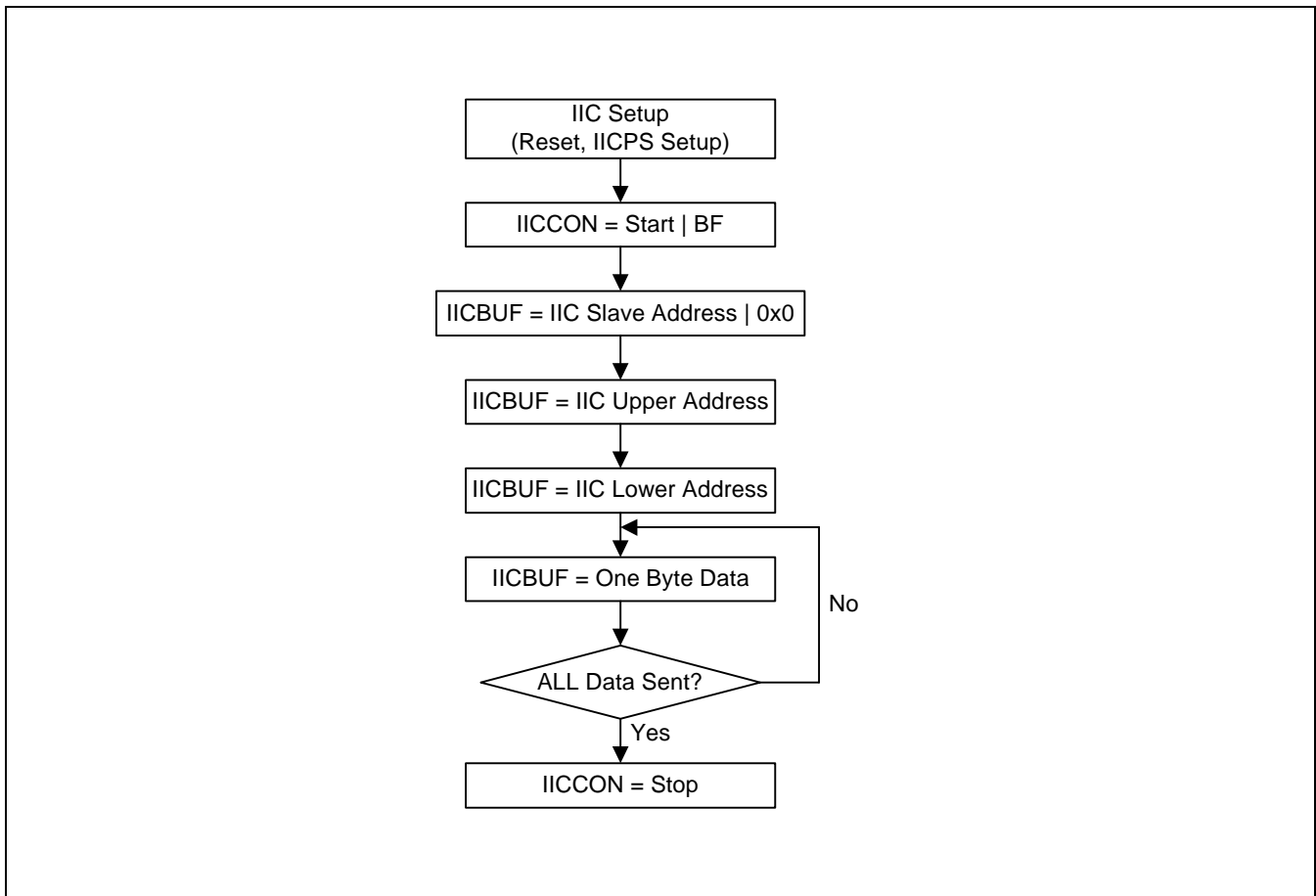
**Figure 6-7. Write Operation Flow Chart**

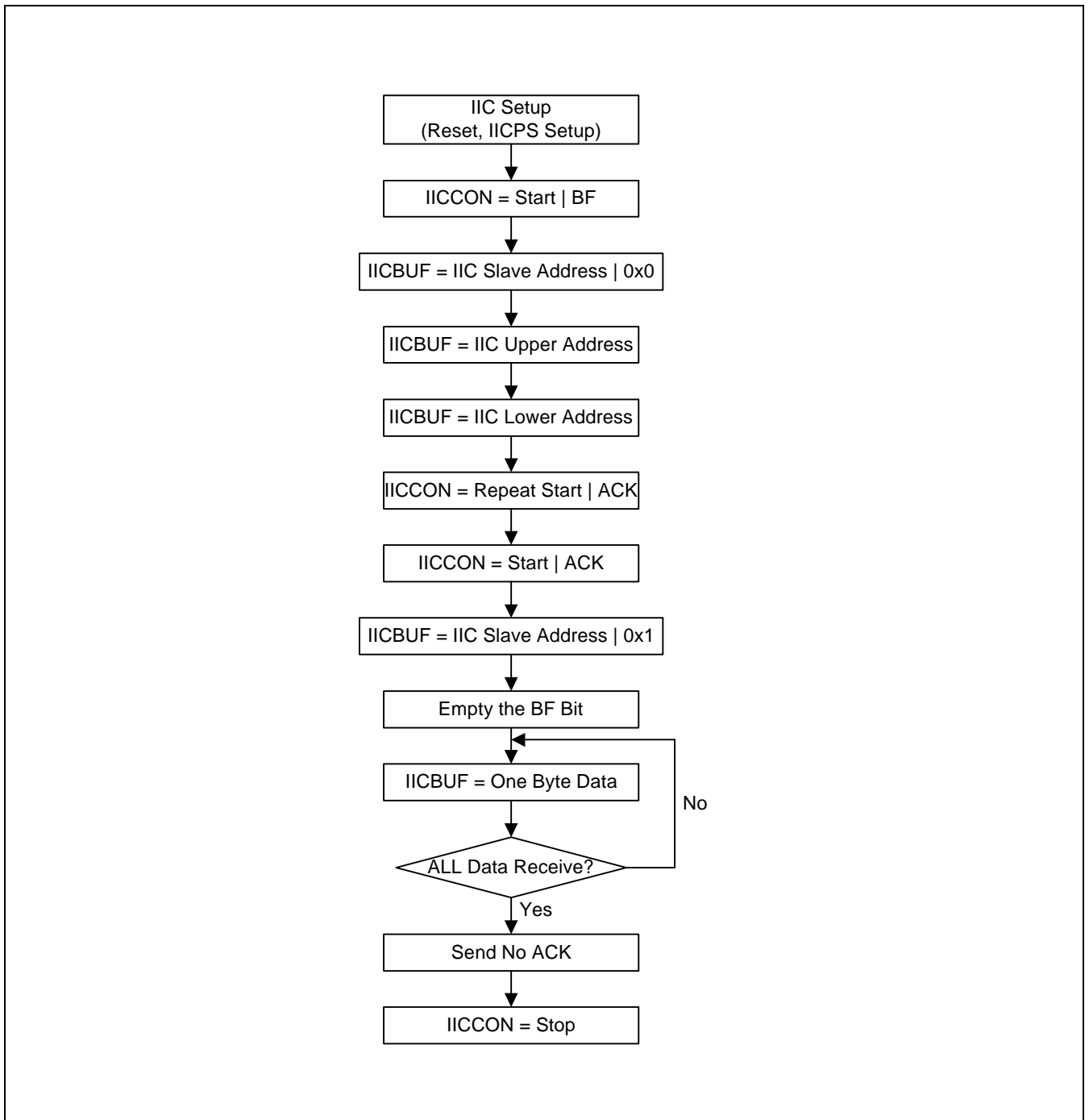

Figure 6-8. Read Operation Flow Chart

NOTES

7 ETHERNET CONTROLLER

7.1 OVERVIEW

The S3C2501X has two Ethernet controllers that operate at either 100M-bit or 10M-bit per second in half-duplex or full-duplex mode. In half-duplex mode, the IEEE 802.3 carrier sense multiple access with collision detection (CSMA/CD) protocol is supported. In full-duplex mode, the IEEE 802.3 MAC control layer is also supported, including the pause operation for flow control.

The two Ethernet controllers support both the media independent interface (MII) and the buffered DMA interface (BDI). The MAC layer consists of a receiver and a transmitter blocks, a flow control block, a content addressable memory(CAM) for storing network addresses, a number of commands, status, and error counter registers.

The MII supplies the transmission and reception clocks of 25MHz for 100M-bps operation, 2.5 MHz for the 10M-bps speed or 1MHz for (the 1M-bps for) Home PNA. The MII conforms to the ISO/IEC 802-3 standards.

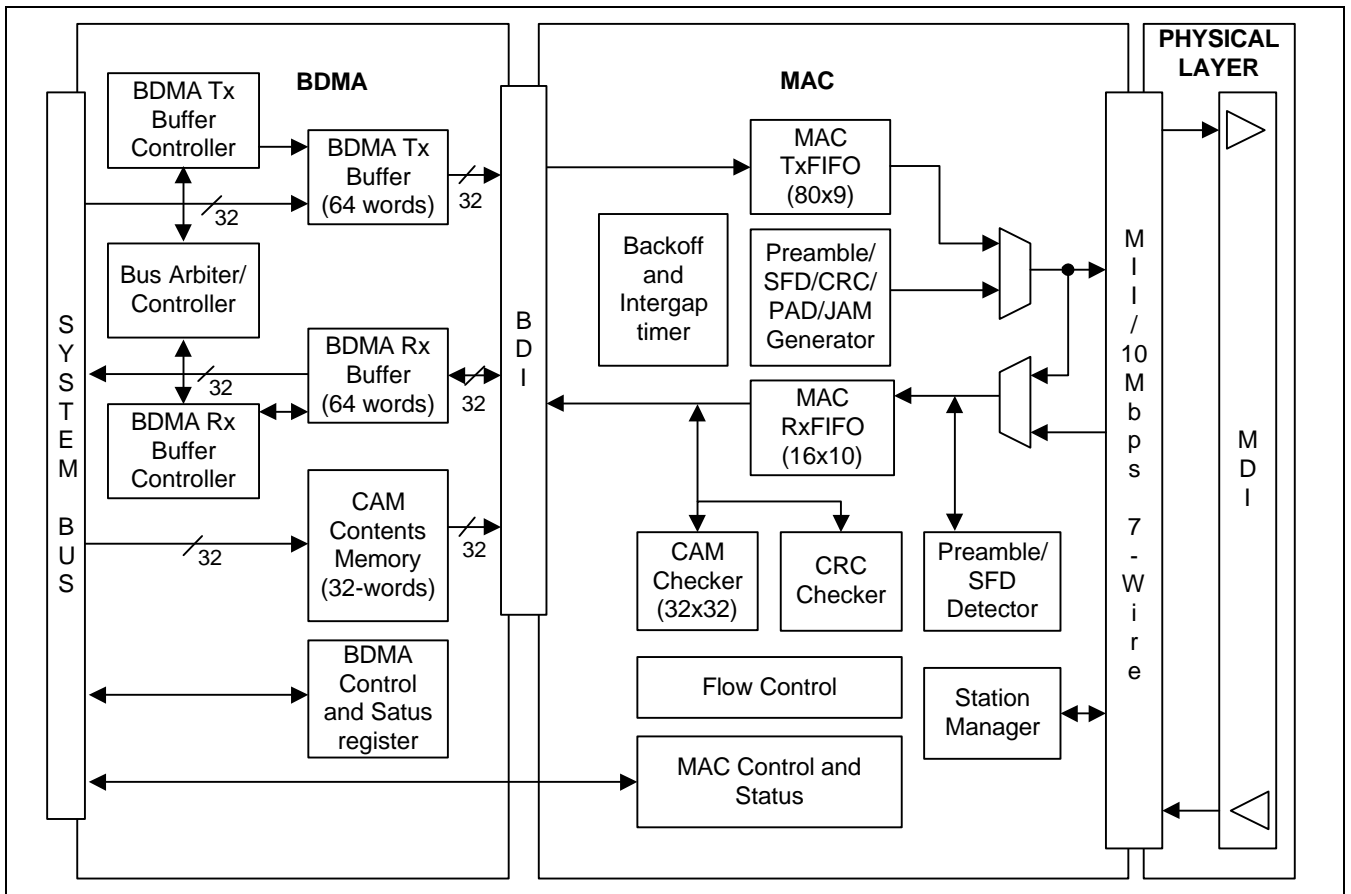

Figure 7-1. Ethernet Diagram

7.2 FEATURES

The most important features and benefits of each Ethernet controller are as follows:

- Cost-effective connection to an external NIC/Ethernet backbone
- Buffered DMA (BDMA) engine with burst mode
- BDMA Tx/Rx Buffers (BTxBUFF and BRxBUFF: 256 bytes/256 bytes)
- MAC Tx/Rx FIFOs(MTxFIFO and MRxFIFO: 80 bytes/16 bytes) to support re-transmission after collision without DMA request and DMA latency
- Data alignment logic
- Old and new physical media support (compatible with existing 10M-bps networks)
- 100M-bps or 10M-bps operation to allow price/performance options and to support phased conversions
- Full IEEE 802.3 compatibility for existing applications
- Media Independent interface (MII) or 7-wire interface
- Station management (STA) signaling for external physical layer configuration and link negotiation
- On-chip CAM (21 MAC addresses)
- Full-duplex mode for doubled bandwidth
- Hardware support of pause operation for full-duplex flow control
- Long frame mode for specialized environment
- Short frame mode for fast testing
- PAD generation for easy processing and reduced processing time

7.3 MAC FUNCTION BLOCKS

The major function blocks of each Ethernet of MAC layer are described in Table 7-1 and Figure 7-1.

Table 7-1. MAC Function Block Descriptions

Function Block	Description
Media Independent Interface (MII)	The interface between the physical layer and the transmit/receiver blocks.
Transmitter block	Moves the outgoing data from the transmit buffer to the MII. This includes circuits for generating the CRC, checking parity, and generating preamble or jam. Also has timers for back-off after collision and the inter-frame gap follows a transmission.
Receiver block	Accepts incoming data from the MII and stores it in the MRxFIFO. The receiver block has logic for computing and checking the CRC value, generating parity for data from the MII, and checking minimum and maximum frame lengths. Also has a CAM that provides for address lookup, and for acceptance or rejection for frame based on their destination address.
Flow control block	Recognizes MAC-control frame and supports the pause operation for full-duplex links. The flow control block also supports generation of pause frame, and provides timers and counters for pause control.
MAC control (command) and status registers	Controls programmable options, including the enabling or disabling of signals that notify the system when conditions occur. The status registers hold information for error handling software, and the error counters accumulate statistical information for network management software.
Loop-back circuit	Provides for MAC-layer testing in isolation from the MII and physical layer.

7.3.1 MEDIA INDEPENDENT INTERFACE (MII)

Both transmitter and receiver blocks operate using the MII, which was developed by the IEEE802.3 task force on 100-Mbps Ethernet. This interface has the following characteristics:

- Media independence
- Multi-vendor points of interoperability
- Supports connection of MAC layer and physical layer entity (PHY) devices
- Capable of supporting both 100M-bps and 10M-bps and 1M-bps data rates
- Data and delimiters are synchronous to clock references
- Provides independent 4-bit wide transmit and receive data paths
- Uses TTL signal levels that are compatible with common digital CMOS ASIC processes
- Supports connection of PHY layer and station management (STA) devices
- Provides a simple management interface
- Capable of driving a limited length of shielded cable

7.3.2 PHYSICAL LAYER ENTITY (PHY)

The physical layer entity, or PHY, performs all of the decoding/encoding on incoming and outgoing data. The manner of decoding and encoding (Manchester for 10BASE-T, 4B/5B for 100BASE-X, or 8B/6T for 100BASE-T4) does not affect the MII. The MII provides the raw data it receives, starting with the preamble and ending with the CRC. The MII expects raw data for transmission, also starting with the preamble and ending with the CRC. The MAC layer also generates jam data and transmits it to the PHY.

7.3.3 BUFFERED DMA INTERFACE (BDI)

The buffered DMA interface (BDI) supports read and write operations across the system bus. Two eight-bit buses transfer data with optional parity checking. The system interface initiates data transfers. The MAC-layer controller responds with a ready signal to accept data for transmission, or to deliver data which has been received. An end-of-frame signal indicates the boundary between packets.

7.3.4 THE MAC TRANSMITTER BLOCK

The MAC transmitter block is responsible for transmitting data. It complies with the IEEE802.3 standard for the carrier sense multiple access with collision detection (CSMA/CD) protocol.

7.3.4.1 MAC TxFIFO(MTxFIFO)

The MTxFIFO has an 80-byte depth. An extra bit is associated with each data byte for parity checking. This 80-byte by 9-bit size allows the first 64 bytes of a data frame to be stored and retransmitted, without further system involvement, in case of a collision. If no collision occurs and transmission is underway, the additional 16 bytes handle system latency and avoid FIFO under-run.

When the system interface has set the MACTXCON.0 bit, the transmission state machine requests data from the BDI. The system controller then fetches data from the system memory.

The data is stored in the MTxFIFO until the threshold for transmit data is satisfied. When the MTxFIFO is not full, a request is issued to the BDI for more data. It then appends the calculated CRC to the end of the data (unless the CRC truncate bit in the transmit control register is set).

7.3.4.2 Preamble and Jam Generator

As soon as the MACTXCON.0 bit is set and there are eight bytes of data in the MTxFIFO, the transmission state machine starts the transmission by asserting the TX_EN signal and transmitting the preamble and the start frame delimiter (SFD). In case there is a collision, it transmits a 32-bit string of `1's after the preamble as a jam pattern.

7.3.4.3 PAD Generator

If a short data frame is transmitted, the MAC will normally generate pad bytes to extend the frame to a minimum of 64 bytes. The pad bytes consist entirely of `0' bits. A control bit is also used to suppress the generation of pad bytes.

7.3.4.4 Parallel CRC Generator

The CRC generation of the outgoing data starts from the destination address and continues through the data field. You can suppress CRC generation by setting the appropriate bit in the transmit control register. This is useful in testing, for example, to force the transmission of a bad CRC in order to test error detection in the receiver. It can also be useful in certain bridge or switch applications, where end-to-end CRC checking is desired.

7.3.4.5 Threshold Logic and Counters

The transmission state machine uses a counter and logic to control the threshold of when the transmission can begin. Before transmitting the MAC waits until eight bytes or a complete frame has been placed in the MTxFIFO. This gives the DMA engine some latency without causing an underflow during transmission.

7.3.4.6 Back-Off and Retransmit Timers

When a collision is detected on the network, the transmitter block stops the transmission and starts a jamming pattern to ensure that all the nodes detect the collision. After this, the transmitter waits for a minimum of 96 bit times and then retransmits the data. After 16 attempts, the transmission state machine sets an error bit and generates an interrupt, if enabled, to signify the failure to transmit a frame due to excessive collisions. It flushes the MTxFIFO, and the MAC is ready for the next frame.

7.3.4.7 Transmit Data Parity Checker

Data in the FIFO is even-parity. When data is read for transmission, the transmission state machine checks the parity. If a parity error is detected, the transmit data parity checker does the following:

- It stops transmission.
- It sets the parity error bit in the transmit status register.
- It generates an interrupt, if enabled.

7.3.4.8 Transmission State Machine

The transmission state machine is the central control logic for the transmitter block. It controls the passing of signals, the timers, and the posting of errors in the status registers.

7.3.5 THE MAC RECEIVER BLOCK

It complies with the IEEE802.3 standard for carrier sense multiple access with collision detection (CSMA/CD) protocol.

After it receives a frame, the receiver block checks for a number of error conditions: CRC errors, alignment errors, and length errors. By setting bits in appropriate control registers some error condition is disabled. Depending on the CAM status, the destination address and the receiver block may reject an otherwise acceptable frame.

7.3.5.1 MAC RxFIFO (MRxFIFO)

The MRxFIFO accepts data one byte at a time. The parity starts with the destination address. The receiver updates the counter with the number of bytes received. As the FIFO stores the data, the CAM block checks the destination address against its stored address. If the CAM recognizes the address, the MRxFIFO continues receiving the frame. If the CAM block does not recognize the address and rejects the frame, the receiver block discards the frame and flushes the MRxFIFO.

7.3.5.2 CAM and Address Recognition

The CAM compares the destination address of the received frame to stored addresses. If it finds a match, the receive state machine continues to receive the frame. The CAM is organized to hold six-byte address entries. The CAM can store 21 address entries.

The CAM address entries 0, 1, and 18 are used to send the pause control frame. To send a pause control frame, you must write the destination address to CAM0, the source address to CAM1, and length/type, op-code, and operand to the CAM18 entry. You must write the MAC transmit control register to set the send pause control bit. In addition, CAM19 and CAM20 can be used to construct a user-define control frame.

7.3.5.3 Parallel CRC Checker

The receiver block computes a CRC across the data and the transmitted CRC, and then checks that the resulting syndrome is valid. A parallel CRC checking scheme handles data arriving in 4-bit nibbles at 100M-bps. To support full-duplex operation, the receiver and transmitter blocks have independent CRC circuits.

7.3.5.4 Receive State Machine

In MII mode, the receiver block receives data from the MII on the RXD[3:0] lines. This data is synchronized to RX_CLK at 25 MHz or 2.5MHz. In 7-wire mode, and at 10MHz, data is received on the RXD_10M line only.

After it detects the preamble and SFD, the receive state machine arranges data in byte configurations, generates parity, and stores the result in the MRxFIFO one byte at a time. If the CAM block accepts the destination address, the MRxFIFO stores the rest of the frame. Any error in reception will reset the MRxFIFO and the state machine will wait for the end of the current frame. It will then be idle while it is waiting for the next preamble and SFD.

7.3.5.5 BDMA Interface Receive State Machine

The BDMA I/F receive state machine issues the Rx_rdy signal whenever data is present in the receive FIFO. The last byte of the packet is signaled by asserting the Rx_EOF.

In case there are any errors during the reception, or if there is a CRC error at the end, the BDMA I/F receive state machine asserts the Rx_toss signal to indicate that the received packet should be discarded.

7.3.6 FLOW CONTROL BLOCK

Flow control is done using the MAC control frame. The receiver sends control frames to the transmitter and the transmitter pauses its operation during the time interval specified in the control frames. The flow control block provides the following functions:

- Recognition of MAC control frames received by the receiver block
- Transmission of MAC control frames, even if transmitter is paused
- Timers and counters for pause operation
- Command and status register (CSR) interface
- Options for passing MAC control frames through to software drivers

For details, refer to the full-duplex pause operation section in this chapter.

7.3.7 BUFFERED DMA (BDMA) OVERVIEW

The BDMA engine controls the data feeding and reception between the MAC and the system bus (AMBA) using two buffers, BDMA TxBUFF (BTxBUFF) and BDMA RxBUFF (BRxBUFF). The BTxBUFF and BRxBUFF hold data and status information for frames being transmitted and received, respectively. Each buffer is controlled by the block, which consists of a bus arbiter, a control and status block, buffer descriptors.

7.3.7.1 Bus Arbiter

The bus arbiter decides which of the BDMA buffer controllers, transmit (Tx) or receive (Rx), has the highest priority for accessing the system bus. The prioritization is dynamic. The BDMA arbiter outputs a bus request signal (nREQ) to the AMBA when Rx Buffer (BRxBUFF) contains 4-words data, or EOF (End of Frame) was saved to the buffer, or Tx Buffer (BTxBUFF) contains 4-word free space.

After it receives a bus acknowledgement signal (nACK) from the AMBA, the BDMA bus arbiter determines the correct bus access priority.

7.3.7.2 Control and Status

This block controls the read/write operations of the bus master across the AMBA. The control logic supports the following operations:

- Fixed 4-word burst size control between Tx and Rx.
- Transmit threshold control (based on 1/8 of transmit buffer size) to match transmission latency to system bus latency.
- Little-Endian byte swapping, to support the data transfer of Little-Endian memory usage for frame data.
- A transmit/receive alignment widget to circumvent word alignment restrictions.

The beginning of a frame should be placed on word boundary. Misalignment of the BDMA transfer would complicate the design of the DMA and degrade the performance. To avoid this, you can use an alignment widget between the BDMA Buffer (word) and the MAC FIFO (byte) by controlling the widget field in Tx buffer descriptor. The widget discards the first 'n' bytes (up to three), where 'n' is the value read from the Tx buffer descriptor that configures the alignment widget.

In the receiver, the BDMA bus arbiter inserts a programmable number of bytes (up to three) into the received data stream while the preamble is being received. This adds some padding to the beginning of the frame. This padding can then be used to solve the alignment problem without having to use a copy of the buffer. Because the data is inserted prior to the concatenation of bytes into words, it does not misalign the subsequent DMA transfer. The number of the alignment bytes is read from the BDMARXCON.5-4 (BRxWA).

7.3.7.3 Buffer Descriptor

The ownership bit in the buffer descriptor controls the owner of the descriptor. When the ownership bit is '1', the BDMA controller owns the descriptor. When the bit is '0', the CPU owns the descriptor. The owner of the descriptor always owns the associated data frame. (The descriptor's frame start address field always points to this frame.)

Software sets the BDMARXLEN register to the length, and also sets the BDMARXDPTN register to point to a chain of buffer descriptors, all of which have their ownership bits set.

The BDMA engine can then be started to set the BDMARXCON.10 (BRxEn). When a frame is received, it is copied into the external memory at the address specified by the BDMARXDPTN register. Please note that no configurable offset or page boundary calculation is required. The received frame is written into the buffer in the external memory until the end of frame is reached, or until the length exceeds the configured maximum frame size. If the entire frame is received successfully, the status bits in the buffer descriptor are set to indicate this. Otherwise, the status bits are set to indicate that an error occurred. The ownership bit in the status and length field is cleared and an interrupt may now be generated. The length field in the Rx buffer descriptor is updated in summation with previous length field of Rx buffer descriptor. The BDMA points the next buffer descriptor automatically, but BDMATXDPTN and BDMARXDPTN is not updated to the next pointer. It always has the first buffer descriptor address. Because BDMA pointers are fixed as initial addresses, BDMA count register values indicate the number of frames to be handled by BDMA.

In addition, users can determine how many buffer descriptors to use by controlling the BDMATXCON.3-0 (BTxNBD) and BDMARXCON.3-0 (BRxNBD). If the last buffer descriptor was used by the BDMA, the next buffer is the first buffer and BDMA count register value goes to zero. Finally, the status and length fields in the first and the last Rx buffer descriptors are updated. The length field value is same in the first and last Rx buffer descriptor. The status field of the middle Rx buffer descriptors does not have any mean.

When the received frame size exceeds the maximum frame size (BRxMFS bits of BDMARXLEN), the data frame will be overwritten by the last word of maximum frame. If overflow occurred, this status is written to status field bit.20 in the Rx buffer descriptor. When the BDMA reads a descriptor, if the ownership bit is not set, it has two options:

- Skip to the next buffer descriptor, or
- Generate an interrupt and halt the BDMA operation. If CPU set to skip bit in Rx buffer descriptor's status field, BDMA goes next buffer without interrupt or BDMA stop.

During transmission, the two-byte frame length at the Tx buffer descriptor is moved into the BDMA internal Tx counter. After transmission, Tx status is saved in the Tx buffer descriptor. The BDMA points to the next buffer descriptor address register for the linked list structure. However, BDMATXDPTN register cannot be updated. You should check BTXBDCNT register to detect how many frames were handled.

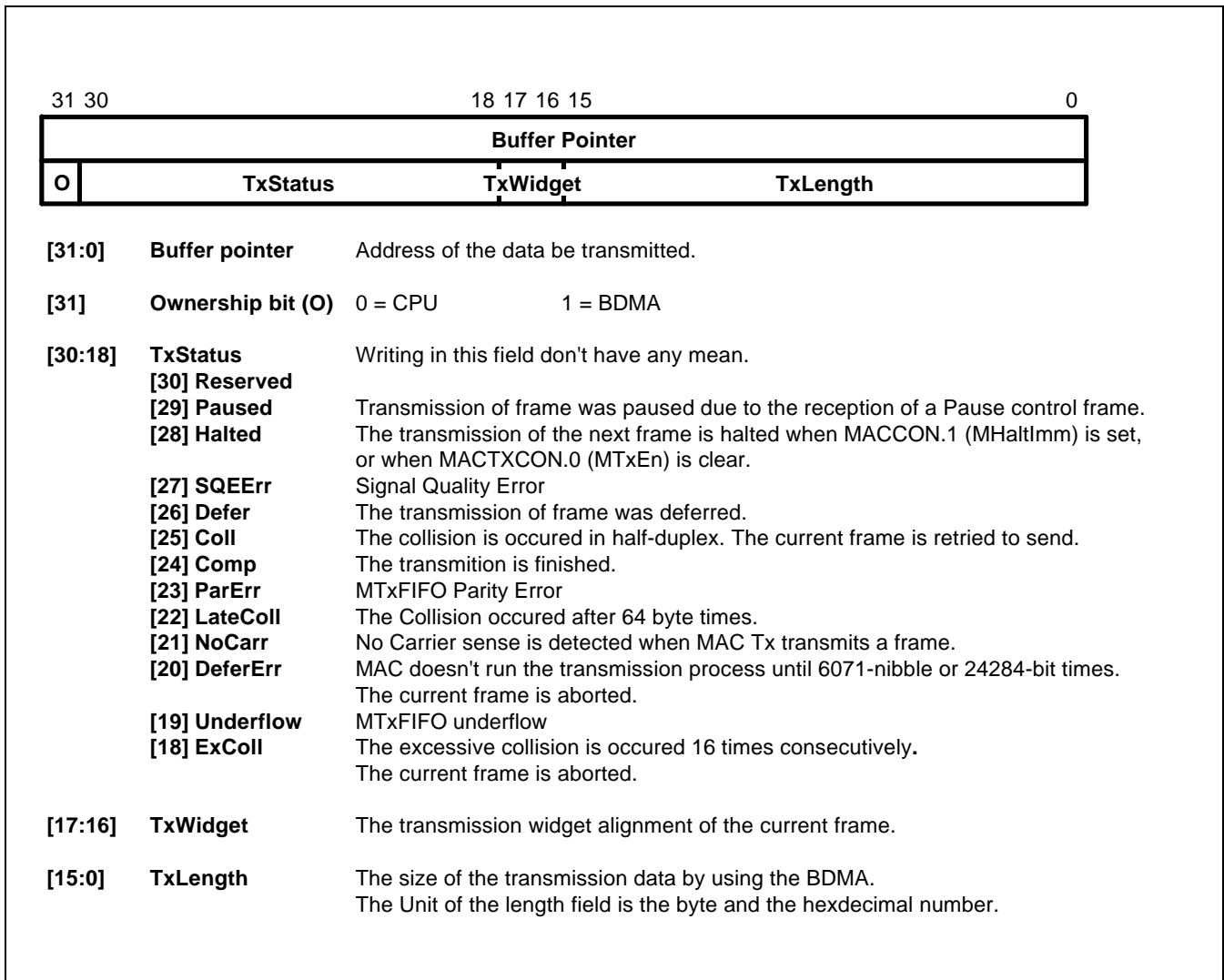

Figure 7-2. Data Structure of Tx Buffer Descriptor

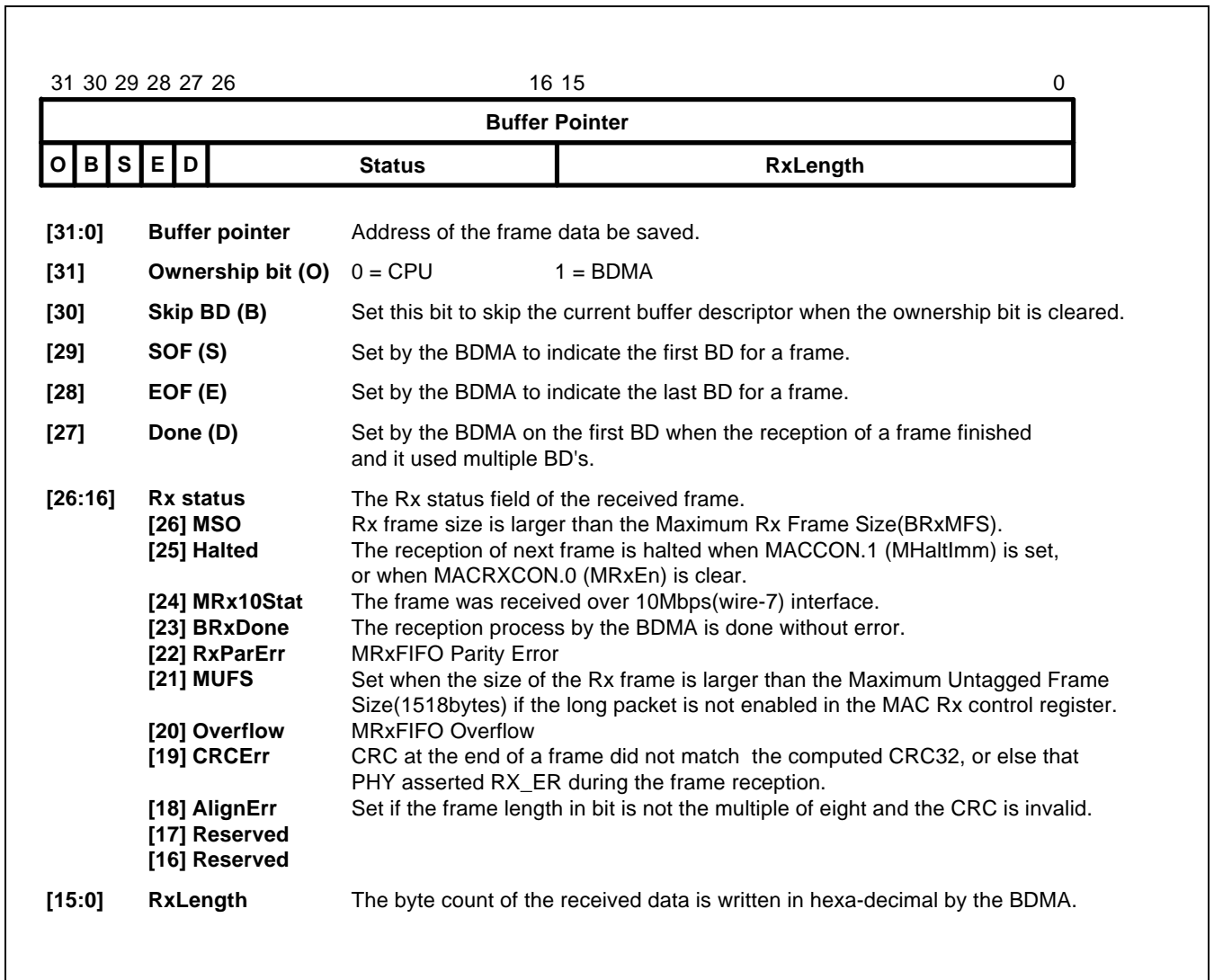

Figure 7-3. Data Structure of Rx Buffer Descriptor

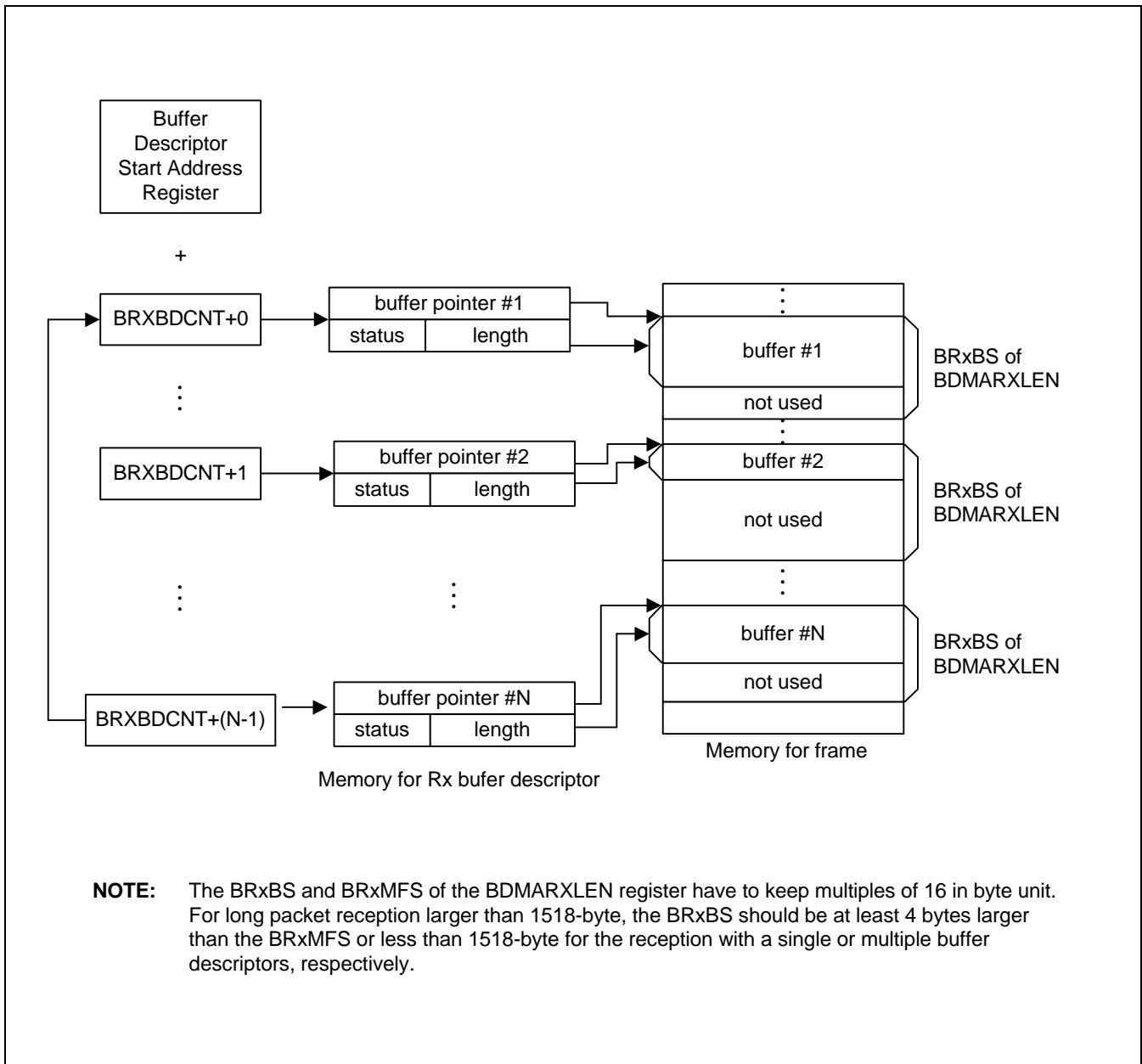

Figure 7-4. Data Structure of the Receive Frame

7.4 ETHERNET CONTROLLER SPECIAL REGISTERS

There are two Ethernet controllers in S3C2501X. They are same each other except the base addresses for internal registers.

Table 7-2. ETHERNET 0 Special Registers

Registers	Address	R/W	Description	Reset Value
BDMATXCONA	0xF00A0000	R/W	Buffered DMA transmit control register	0x00000000
BDMARXCONA	0xF00A0004	R/W	Buffered DMA receive control register	0x00000000
BDMATXDPTRA	0xF00A0008	R/W	Transmit buffer descriptor start address	0x00000000
BDMARXDPTRA	0xF00A000C	R/W	Receive buffer descriptor start address	0x00000000
BTXBDCNTA	0xF00A0010	R/W	BDMA Tx buffer descriptor counter	0x00000000
BRXBDCNTA	0xF00A0014	R/W	BDMA Rx buffer descriptor counter	0x00000000
BMTXINTENA	0xF00A0018	R/W	BDMA/MAC Tx Interrupt enable register	0x00000000
BMRXINTENA	0xF00A001C	R/W	BDMA/MAC Rx Interrupt enable register	0x00000000
BMTXSTATA	0xF00A0020	R/W	BDMA/MAC Tx Status register	0x00000000
BMRXSTATA	0xF00A0024	R/W	BDMA/MAC Rx Status register	0x00000000
BDMARXLENA	0xF00A0028	R/W	Receive Frame Size	0x00000000
CFTXSTATA	0xF00A0030	R	Transmit control frame status	0x00000000
MACCONA	0xF00B0000	R/W	MAC control	0x00000000
CAMCONA	0xF00B0004	R/W	CAM control	0x00000000
MACTXCONA	0xF00B0008	R/W	Transmit control	0x00000000
MACTXSTATA	0xF00B000C	R/W	Transmit status	0x00000000
MACRXCONA	0xF00B0010	R/W	Receive control	0x00000000
MACRXSTATA	0xF00B0014	R/W	Receive status	0x00000000
STADATAA	0xF00B0018	R/W	Station management data	0x00000000
STACONA	0xF00B001C	R/W	Station management control and address	0x00006000
CAMENA	0xF00B0028	R/W	CAM enable	0x00000000
MISSCNTA	0xF00B003C	R(Clr)/W	Missed error count	0x00000000
PZCNTA	0xF00B0040	R	Pause count	0x00000000
RMPZCNTA	0xF00B0044	R	Remote pause count	0x00000000
CAMA	0xF00B0080- 0xF00B00FC	W	CAM content (32 words)	Undefined

Table 7-3. ETHERNET 1 Special Registers

Registers	Address	R/W	Description	Reset Value
BDMATXCONB	0xF00C0000	R/W	Buffered DMA transmit control register	0x00000000
BDMARXCONB	0xF00C0004	R/W	Buffered DMA receive control register	0x00000000
BDMATXDPTRB	0xF00C0008	R/W	Transmit buffer descriptor start address	0x00000000
BDMARXDPTRB	0xF00C000C	R/W	Receive buffer descriptor start address	0x00000000
BTXBDCNTB	0xF00C0010	R/W	BDMA Tx buffer descriptor counter	0x00000000
BRXBDCNTB	0xF00C0014	R/W	BDMA Rx buffer descriptor counter	0x00000000
BMTXINTENB	0xF00C0018	R/W	BDMA/MAC Tx Interrupt enable register	0x00000000
BMRXINTENB	0xF00C001C	R/W	BDMA/MAC Rx Interrupt enable register	0x00000000
BMTXSTATB	0xF00C0020	R/W	BDMA/MAC Tx Status register	0x00000000
BMRXSTATB	0xF00C0024	R/W	BDMA/MAC Rx Status register	0x00000000
BDMARXLENB	0xF00C0028	R/W	Receive Frame Size	0x00000000
CFTXSTATB	0xF00C0030	R	Transmit control frame status	0x00000000
MACCONB	0xF00D0000	R/W	MAC control	0x00000000
CAMCONB	0xF00D0004	R/W	CAM control	0x00000000
MACTXCONB	0xF00D0008	R/W	Transmit control	0x00000000
MACTXSTATB	0xF00D000C	R/W	Transmit status	0x00000000
MACRXCONB	0xF00D0010	R/W	Receive control	0x00000000
MACRXSTATB	0xF00D0014	R/W	Receive status	0x00000000
STADATAB	0xF00D0018	R/W	Station management data	0x00000000
STACONB	0xF00D001C	R/W	Station management control and address	0x00006000
CAMENB	0xF00D0028	R/W	CAM enable	0x00000000
MISSCNTB	0xF00D003C	R(Clr)/W	Missed error count	0x00000000
PZCNTB	0xF00D0040	R	Pause count	0x00000000
RMPZCNTB	0xF00D0044	R	Remote pause count	0x00000000
CAMB	0xF00D0080- 0xF00D00FC	W	CAM content (32 words)	Undefined

7.4.1 BDMA RELATIVE SPECIAL REGISTER

7.4.1.1 Buffered DMA Transmit Control Register

Table 7-4. BDMATXCON Register

Registers	Address	R/W	Description	Reset Value
BDMATXCONA	0xF00A0000	R/W	Buffered DMA transmit control register	0x00000000
BDMATXCONB	0xF00C0000	R/W	Buffered DMA transmit control register	0x00000000

Bit Number	Bit Name	Description
[3:0]	BDMA Tx Number of Buffer Descriptor (BTxNBD)	You can select number of buffer descriptor. 0000 = 2^0 , 0001 = 2^1 , 0010 = 2^2 , ..., 11xx = 2^{12}
[6:4]	BDMA transmit to MAC Tx start level (BTxMSL)	These bits determine when to move the data of the new frame in the BDMA Tx Buffer (BTxBUFF) to the MAC Tx FIFO (MTxFIFO) at a new frame arrival. 000 means no wait, 001 means wait to fill 1/8 of the BDMA Tx Buffer, 010 means wait to fill 2/8 of the buffer, and so on through 100, which means wait to fill 4/8 of the BDMA Tx Buffer. NOTE: If the last data of the frame arrives in BDMA Tx Buffer, the data transfer from the BDMA Tx Buffer to the MAC Tx FIFO starts immediately, regardless of the level of these bits.
[8:7]	Reserved	Not applicable.
[9]	–	Factorial test bit
[10]	BDMA Tx enable (BTxEn)	When the Tx enable bit is set to '1', the BDMA Tx block is enabled. Even if this bit is disabled, buffer data will be moved to the MAC Tx FIFO until the BDMA Tx BUFF underflows. This bit is automatically cleared when the BDMA is not the owner. NOTE: The BDMATXDPTR register must be assigned before this bit is set.
[11]	BDMA Tx reset (BTxRS)	Set this bit to '1' to reset the BDMA Tx block.
[31:12]	Reserved	

7.4.1.2 Buffered DMA Receive Control Register

Table 7-5. BDMA RXCON Register

Register	Address	R/W	Description	Rest Value
BDMARXCONA	0xF00A0004	R/W	Buffered DMA receive control register	0x00000000
BDMARXCONB	0xF00C0004	R/W	Buffered DMA receive control register	0x00000000

Bit Number	Bit Name	Description
[3:0]	BDMA Rx Number of Buffer Descriptor (BRxNBD)	You can select number of buffer descriptor. 0000 = 2 ⁰ , 0001 = 2 ¹ , 0010 = 2 ² ,....., 11xx = 2 ¹²
[5:4]	BDMA Rx word alignment (BRxWA)	The Rx word alignment bits determine how many bytes are invalid in the first word of each data frame. These invalid bytes are inserted when the word is assembled by the BDMA. '00' = No invalid bytes, '01' = 1 invalid byte, '10' = 2 invalid bytes, and '11' = 3 invalid bytes.
[8:6]	Reserved	Not applicable.
[9]	–	Factorial test bits
[10]	BDMA Rx enable (BRxEn)	When the Rx enable bit is set to '1', the BDMA Rx block is enabled. Even if this bit is disabled, buffer data will be moved to the BDMA RxBUFF until the MAC Rx FIFO underflows. This bit is automatically disabled when the BDMA is not the owner. NOTE: The buffer descriptor start address pointer must be assigned before this bit is set.
[11]	BDMA Rx reset (BRxRS)	Set this bit to '1' to reset the BDMA Rx block.
[31:12]	Reserved	

7.4.1.3 BDMA Transmit Buffer Descriptor Start Address Register

Table 7-6. BDMATXDPTR Register

Registers	Address	R/W	Description	Reset Value
BDMATXDPTRA	0xF00A0008	R/W	BDMA Tx buffer descriptor base register	0x00000000
BDMATXDPTRB	0xF00C0008	R/W	BDMA Tx buffer descriptor base register	0x00000000

Bit Number	Bit Name	Description
[31:0]	BDMA transmit buffer descriptor start address	The BDMA transmit buffer descriptor start address register contains the address of the first buffer descriptor on the frame to be sent.

7.4.1.4 BDMA Receive Buffer Descriptor Start Address Register

Table 7-7. BDMARXDPTR Register

Registers	Address	R/W	Description	Reset Value
BDMARXDPTRA	0xF00A000C	R/W	BDMA Rx buffer descriptor base register	0x00000000
BDMARXDPTRB	0xF00C000C	R/W	BDMA Rx buffer descriptor base register	0x00000000

Bit Number	Bit Name	Description
[31:0]	BDMA receive buffer descriptor start address	The BDMA receive buffer descriptor start address register contains the address of the first buffer descriptor on the frame to be saved.

7.4.1.5 BDMA Transmit Buffer Descriptor Counter

Table 7-8. BTXBDCNT Register

Registers	Address	R/W	Description	Reset Value
BTXBDCNTA	0xF00A0010	R/W	BDMA Tx buffer descriptor counter of Current Pointer	0x00000000
BTXBDCNTB	0xF00C0010	R/W	BDMA Tx buffer descriptor counter of Current Pointer	0x00000000

Bit Number	Bit Name	Description
[11:0]	BDMA Tx buffer descriptor Counter	The maximum counter value is dependent on the BTxNBD of the BDMATXCON register. Buffer descriptor current address = BDMATXDPTR + (BTXBDCNT<<3)

7.4.1.6 BDMA Receive Buffer Descriptor Counter

Table 7-9. BRXBDCNT Register

Registers	Address	R/W	Description	Reset Value
BRXBDCNTA	0xF00A0014	R/W	BDMA Rx buffer descriptor counter of current pointer	0x00000000
BRXBDCNTB	0xF00C0014	R/W	BDMA Rx buffer descriptor counter of current pointer	0x00000000

Bit Number	Bit Name	Description
[11:0]	BDMA Rx buffer descriptor Counter	The maximum counter value is dependent on the BTxNBD of the BDMATXCON register. Buffer descriptor current address = BDMARXDPTR + (BRXBDCNT<<3)

7.4.1.7 BDMA/MAC Transmit Interrupt Enable Register

Table 7-10. BMTXINTEN Register

Registers	Address	R/W	Description	Reset Value
BMTXINTENA	0xF00A0018	R/W	BDMA/MAC Tx Interrupt Enable	0x00000000
BMTXINTENB	0xF00C0018	R/W	BDMA/MAC Tx Interrupt Enable	0x00000000

Bit Number	Bit Name	Description
[0]	Enable MAC Tx excessive collision (ExCollIE)	This bit enables ExColl Interrupt.
[1]	Enable MAC Tx underflow (UnderflowIE)	This bit enables Underflow interrupt.
[2]	Enable MAC Tx deferral (DeferErrIE)	This bit enables DeferErr interrupt.
[3]	Enable MAC Tx no carrier (NoCarrIE)	This bit enables NoCarr interrupt.
[4]	Enable MAC Tx late collision (LateCollIE)	This bit enables LateColl interrupt.
[5]	Enable MAC Tx transmit parity (TxParErrIE)	This bit enables TxParErr interrupt.
[6]	Enable MAC Tx completion (TxCompIE)	This bit enables TxComp interrupt.
[15:7]	Reserved	Not applicable.
[16]	Tx complete to send control frame interrupt enable (TxCFcompIE)	This bit enable TxCFcomp interrupt.
[17]	BDMA Tx not owner interrupt enable (BTxNOIE)	This bit enables BTxNO interrupt.
[18]	BDMA Tx Buffer empty interrupt enable (BTxEmptyIE)	This bit enables BTxEmpty interrupt
[31:19]	Reserved	Not applicable.

7.4.1.8 BDMA/MAC Transmit Interrupt Status Register

Table 7-11. BMTXSTAT Register

Registers	Address	R/W	Description	Reset Value
BMTXSTATA	0xF00A0020	R/W	BDMA/MAC Tx Interrupt Status Register	0x00000000
BMTXSTATB	0xF00C0020	R/W	BDMA/MAC Tx Interrupt Status Register	0x00000000

Bit Number	Bit Name	Description
[0]	Excessive collision (ExColl)	This bit is set when collision occurred 16 times consecutively. In this case, the frame transmission is aborted. If this bit is the cause of the interrupt, MTxEn/BTxEn/MReset bit should be cleared for the re-transmission of the current frame.
[1]	Underflow	This bit is set if the MAC TxFIFO becomes empty during the frame transmission.
[2]	Deferral Error (DeferErr)	This bit is set when MAC doesn't run the transmission process from TX_EN falling to 6,071 nibble times or 24,284 bit times.
[3]	No carrier (NoCarr)	This bit is set if no carrier sense is detected during the transmission frame.
[4]	Late collision (LateColl)	This bit is set if a collision occurs after 512 bit times (or 64 byte times).
[5]	Transmit parity error (TxParErr)	This bit is set if a parity error is detected in the MAC TxFIFO.
[6]	Tx Completion (TxComp)	This bit is set when the transmission always is completed with normal or abnormal status.
[15:7]	Reserved	Not applicable.
[16]	Tx complete to send control frame (TxCFcomp)	This bit is set each time the MAC sends a complete control frame.
[17]	BDMA Tx not owner (BTxNO)	This bit is set when BDMA is not owner and the transmission process is stop.
[18]	BDMA TxBUFF empty (BTxEmpty)	This bit is set when the BDMA TxBUFF is empty.
[31:19]	Reserved	Not applicable.

7.4.1.9 BDMA/MAC Receive Interrupt Enable Register

Table 7-12. BMRXINTEN Register

Registers	Address	R/W	Description	Reset Value
BMRXINTENA	0xF00A001C	R/W	BDMA/MAC Rx Interrupt Enable Register	0x00000000
BMRXINTENB	0xF00C001C	R/W	BDMA/MAC Rx Interrupt Enable Register	0x00000000

Bit Number	Bit Name	Description
[0]	Enable MAC Rx missed roll (MissRollIE)	This bit enables MissRoll interrupt.
[1]	Enable MAC Rx alignment (AlignErrIE)	This bit enables AlignErr interrupt
[2]	Enable MAC Rx CRC error (CRCErrIE)	This bit enables CRCErr interrupt.
[3]	Enable MAC Rx overflow (OverflowIE)	This bit enables Overflow interrupt.
[4]	Enable MAC Rx long error (LongErrIE)	This bit enables LongErr interrupt.
[5]	Enable MAC Rx receive parity (RxParErrIE)	This bit enables RxParErr interrupt.
[6]	–	Factorial test bit
[15:7]	Reserved	Not applicable.
[16]	Enable BDMA Rx done for every received frames (BRxDoneIE)	This bit enables BRxDone interrupt.
[17]	Enable BDMA Rx not owner interrupt (BRxNOIE)	This bit enables BRxNO interrupt.
[18]	Enable BDMA Rx maximum size over interrupt (BRxMSOIE)	This bit enables BRxMSO interrupt.
[19]	Enable BDMA Rx buffer(BRxBUFF) Overflow Interrupt(BRxFullIE)	This bit enables BRxFull interrupt.
[20]	Enable BDMA Rx early notification interrupt (BRxEarlyIE)	This bit enables BRxEarly interrupt.
[31:21]	Reserved	Not applicable.

7.4.1.10 BDMA/MAC Receive Interrupt Status Register

Table 7-13. BMRXSTAT Register

Registers	Address	R/W	Description	Reset Value
BMRXSTATA	0xF00A0024	R/W	BDMA/MAC Rx Interrupt Status register	0x00000000
BMRXSTATB	0xF00C0024	R/W	BDMA/MAC Rx Interrupt Status register	0x00000000

Bit Number	Bit Name	Description
[0]	Missed roll (MissRoll)	This bit is set when the missed error counter rolls over. Whenever this bit is set, the MISSCNT register should be read to clear this bit. Writing by ARM doesn't affect the Rx interrupt.
[1]	Alignment error (AlignErr)	This bit is set if the frame length in bits is not a multiple of eight and the CRC is invalid. For the MAC Rx control mode of MIgnoreCRC, this bit is not set.
[2]	CRC error (CRCErr)	This bit is set if the CRC at the end of frame did not match the computed value, or else the PHY asserted RX_ER during frame reception.
[3]	Overflow error (Overflow)	This bit is set if the MAC RxFIFO was full when it needed to store a received byte.
[4]	Long error (LongErr)	This bit is set if the MAC received a frame longer than 1518 bytes. (It is not set if the long enable bit in the receive control register, MACRXCON, is set.)
[5]	Parity error (RxParErr)	This bit is set if a parity error is detected in the MAC RxFIFO.
[6]	–	Factorial test bit
[15:7]	Reserved	Not applicable.
[16]	BDMA Rx done in every received frames (BRxDone)	This bit is set each time the BDMA receiver moves one received data frame to memory. This bit must be cleared for the next frame interrupt generation.
[17]	BDMA Rx not owner (BRxNO)	This bit is set when BDMA is not the owner and the reception process is stop.
[18]	BDMA Rx maximum size over (BRxMSO)	This bit is set when the value of received frame size is larger than one of the Rx frame maximum size.
[19]	BDMA RxBUFF Full (BRxFull)	This bit is set when the BDMA RxBUFF is in the full-flag state.
[20]	Early notification (BRxEarly)	This bit is set when the BDMA moves the Length/Ether-type field of the current frame to the external memory.
[21]	One more frame data in BDMA RxBUFF (BRxFRF), read-only	This bit is set whenever an additional data frame is received in the BDMA receive buffer.
[26:22]	Number of frames in BRxBUFF (BRxNFR), read-only	These bits appear number of frames in BRxBUFF.
[31:27]	Reserved	Not applicable

7.4.1.11 BDMA Receive Frame Size Register

Table 7-14. BDMARXLEN Register

Registers	Address	R/W	Description	Reset Value
BDMARXLENA	0xF00A0028	R/W	Receive frame size	Undefined
BDMARXLENB	0xF00C0028	R/W	Receive frame size	Undefined

Bit Number	Bit Name	Description
[11:0]	BDMA Rx Buffer Size (BRxBS)	This register value specifies the buffer size allocated to each buffer descriptor. Thus, for an incoming frame larger than the BRxBS, multiple buffer descriptors are used for the frame reception. NOTE: BRxBS value has to keep multiples of 16 in byte unit. For long packet reception larger than 1518 bytes, the BRxBS should be at least 4 bytes larger than the BRxMFS or less than 1518 bytes for the reception with a single or multiple buffer descriptor, respectively.
[15:12]	Reserved	Not applicable
[27:16]	BDMA Maximum Rx Frame Size (BRxMFS)	This register value controls how many bytes per frame can be saved to memory. If the received frame size exceeds these values, an error condition is reported. NOTE: BRxMFS value has to keep multiples of 16 in byte unit.
[31:28]	Reserved	Not applicable

7.4.2 MAC RELATIVE SPECIAL REGISTER

7.4.2.1 MAC Transmit Control Frame Status

The transmit control frame status register, CCTXSTAT provides the status of a MAC control frame as it is sent to a remote station. This operation is controlled by the MSdPause bit in the transmit control register, MACTXCON.

It is the responsibility of the BDMA engine to read this register and to generate an interrupt to notify the system that the transmission of a MAC control packet has been completed.

Table 7-15. CCTXSTAT Register

Registers	Address	R/W	Description	Reset Value
CCTXSTATA	0xF00A0030	R	Transmit control frame status	0x00000000
CCTXSTATB	0xF00C0030	R	Transmit control frame status	0x00000000

Bit Number	Bit Name	Description
[15:0]	MACTXSTAT[15:0]	A 16-bit value indicating the status of a MAC control packet as it is sent to a remote station. Read by the BDMA engine.

7.4.2.2 MAC Control Register

The MAC control register provides global control and status information for the MAC. The MLINK10 bit is a status bit. All other bits are MAC control bits.

MAC control register settings affect both transmission and reception.

After a reset is complete, the MAC controller clears the reset bit. Not all PHYs support full-duplex operation. (Setting the MAC loopback bit overrides the full-duplex bit.) Also, some 10M-b/s PHYs may interpret the loop 10 bit to control different functions, and manipulate the link10 bit to indicate a different status condition.

Table 7-16. MACCON Register

Registers	Address	R/W	Description	Reset Value
MACCONA	0xF00B0000	R/W	MAC control	0x00000000
MACCONB	0xF00D0000	R/W	MAC control	0x00000000

Bit Number	Bit Name	Description
[0]	Halt request (MHaltReq)	Set this bit to stop data frame transmission and reception as soon as Tx/Rx of any current frames has been completed.
[1]	Halt immediate (MHaltImm)	Set this bit to immediately stop all transmission and reception.
[2]	Software reset (MReset)	Set this bit to reset all MAC control and status register and MAC state machines. This bit is automatically cleared.
[3]	Full-duplex	Set this bit to start transmission while reception is in progress.
[4]	MAC loopback (MLoopBack)	Set this bit to cause transmission signals to be presented as input to the receive circuit without leaving the controller.
[5]	Reserved	Not applicable
[6]	MII-OFF	Use this bit to select the connection mode. If this bit is set to one, 10M-bits/s interface will select the 10M-bits/s endec. Otherwise, the MII will be selected.
[7]	Loop 10 Mb/s (MLOOP10)	If this bit is set, the Loop_10 external signal is asserted to the 10M-b/s endec.
[11:8]	Reserved	Not applicable.
[12]	MDC-OFF	Clear this bit to enable the MDC clock generation for power management. If it is set to one, the MDC clock generation is disabled.
[14:13]	Reserved	Not applicable.
[15]	Link status 10 Mb/s (MLINK10), read-only	This bit value is read as a buffered signal on the link 10 pin.
[31:16]	Reserved	Not applicable.

7.4.2.3 CAM Control Register

The three acceptance bits (MStation, MGroup, and MBroad) in the CAM control register are used to override the address comparison mode by the compare enable bit(MCompEn). By setting the CAM control register, it is possible to accept frames with all types of destination addresses. The three types of destination address are as follows:

- Broadcast address: defined as FF-FF-FF-FF-FF-FF.
- Unicast (Station) address: addresses with an even first byte. For example, 00-FF-FF-FF-FF-FF.
- Multicast (Group) address: addresses with an odd first byte, but not the Broadcast address. For example, 01-00-00-00-00-00.

CAM comparison mode: MCompEn = '1', MNegCAM = '0'

The CAM controller compares the destination address of the incoming frame with the CAM addresses enabled by the CAM Enable (CAMEN) register. The controller accepts only the frames with the matched destination addresses.

Negative CAM comparison mode: MCompEn = '1', MNegCAM = '1'

The address comparison is same as the CAM comparison mode. But, the CAM controller rejects the frames with the matched destination addresses and accepts frames with the address outside the CAM address enabled.

No CAM comparison mode: MCompEn = '0'

The CAM controller accepts frames with all types of destination addresses.

Table 7-17. CAMCON Register

Registers	Address	R/W	Description	Reset Value
CAMCONA	0xF00B0004	R/W	CAM control	0x00000000
CAMCONB	0xF00D0004	R/W	CAM control	0x00000000

Bit Number	Bit Name	Description
[0]	Station accept (MStation)	Set this bit to accept unicast (i.e. station) frames.
[1]	Group accept (MGroup)	Set this bit to accept multicast (i.e. group) frames.
[2]	Broadcast accept (MBroad)	Set this bit to accept broadcast frames.
[3]	Negative CAM (MNegCAM)	Set this bit to enable the Negative CAM comparison mode.
[4]	Compare enable (MCompEn)	Set this bit to enable the CAM comparison mode.
[31:5]	Reserved	Not applicable.

7.4.2.4 MAC Transmit Control Register

Table 7-18. MACTXCON Register

Registers	Address	R/W	Description	Reset Value
MACTXCONA	0xF00B0008	R/W	Transmit control	0x00000000
MACTXCONB	0xF00D0008	R/W	Transmit control	0x00000000

Bit Number	Bit Name	Description
[0]	Transmit enable (MTxEn)	Set this bit to enable transmission. To stop transmission immediately, clear the transmit enable bit to '0'.
[1]	Transmit halt request (MTxHalt)	Set this bit to halt the transmission after completing the transmission of any current frame.
[2]	Suppress padding (MNoPad)	Set this bit not to generate pad bytes for frames of less than 64 bytes.
[3]	Suppress CRC (MNoCRC)	Set this bit to suppress addition of a CRC at the end of a frame.
[4]	Fast back-off (MFBack)	Set this bit to use faster back-off times for testing.
[5]	No defer (MNoDef)	Set this bit to disable the defer counter. (The defer counter keeps counting until the carrier sense (CrS) bit is turned off.)
[6]	Send Pause (MSdPause)	Set this bit to send a pause command or other MAC control frame. The send pause bit is automatically cleared when a complete MAC control frame has been transmitted. Writing a '0' to this register bit has no effect.
[7]	MII 10M-b/s SQE test mode enable (MSQEn)	Set this bit to enable MII 10M-b/s SQE test mode.
[31:8]	Reserved	Not applicable.

7.4.2.5 MAC Transmit Status Register

A transmission status flag is set in the transmit status register, MACTXSTAT, whenever the corresponding event occurs. In addition, an interrupt is generated if the corresponding enable bit in the transmit control register is set. A MAC TxFIFO parity error sets TxParErr, and also clears MTxEn, if the interrupt is enabled.

Table 7-19. MACTXSTAT Register

Registers	Address	R/W	Description	Reset Value
MACTXSTATA	0xF00B000C	R/W	Transmit status	0x00000000
MACTXSTATB	0xF00D000C	R/W	Transmit status	0x00000000

Bit Number	Bit Name	Description
[7:0]	–	These bits are equivalent to the BMTXSTAT.7-0
[11:8]	Transmission collision count (MColLCnt)	This 4-bit value is the count of collisions that occurred while successfully transmitting the frame.
[12]	Transmission deferred (MTxDefer)	This bit is set if transmission of a frame was deferred because of a delay during transmission.
[13]	Signal quality error (SQEErr)	According to the IEEE802.3 specification, the SQE signal reports the status of the PMA (MAU or transceiver) operation to the MAC layer. After transmission is complete and 1.6 ms has elapsed, a collision detection signal is issued for 1.5 ms to the MAC layer. This signal is called the SQE test signal. The MAC sets this bit if this signal is not reported within the IFG time of 6.4ms.
[14]	Transmission halted (MTxHalted)	This bit is set if the MTxEn bit is cleared or the MHaltImm bit is set
[15]	Paused (MPaused)	This bit is set if transmission of frame was delayed due to a Pause being received.
[31:16]	Reserved	Not applicable.

7.4.2.6 MAC Receive Control Register

Table 7-20. MACRXCON Register

Registers	Offset	R/W	Description	Reset Value
MACRXCONA	0xF00B0010	R/W	Receive control	0x00000000
MACRXCONB	0xF00D0010	R/W	Receive control	0x00000000

Bit Number	Bit Name	Description
[0]	Receive enable (MRxEn)	Set this bit to '1' to enable MAC receive operation. If '0', stop reception immediately.
[1]	Receive halt request (MRxHalt)	Set this bit to halt reception after completing the reception of any current frame.
[2]	Long enable (MLongEn)	Set this bit to receive frames with lengths greater than 1518 bytes.
[3]	Short enable (MShortEn)	Set this bit to receive frames with lengths less than 64 bytes.
[4]	Strip CRC value (MStripCRC)	Set this bit to check the CRC, and then strip it from the message.
[5]	Pass control frame (MPassCtl)	Set this bit to enable the passing of control frames to a MAC client.
[6]	Ignore CRC value (MIgnoreCRC)	Set this bit to disable CRC value checking.
[31:7]	Reserved	Not applicable.

7.4.2.7 MAC Receive Status Register

A receive status flag is set in the MAC receive status register, MACRXSTAT, whenever the corresponding event occurs. When a status flag is set, it remains set until another packet arrives, or until software writes a '1' to the flag to clear the status bit. If the corresponding interrupt enable bit in the receive control register is set, an interrupt is generated whenever a status flag is set. A MAC receive parity error sets RxParErr, and also clears the MRxEn bit (if an interrupt is enabled).

Table 7-21. MACRXSTAT Register

Registers	Address	R/W	Description	Reset Value
MACRXSTATA	0xF00B0014	R/W	Receive status	0x00000000
MACRXSTATB	0xF00D0014	R/W	Receive status	0x00000000

Bit Number	Bit Name	Description
[7:0]	–	These bits are equal to the BMRXSTAT.7-0
[8]	Short Frame Error (MRxShort)	This bit is set if the frame was received with short frame.
[9]	Receive 10-Mb/s status (MRx10Stat)	This bit is set to '1' if the frame was received over the 7-wire interface or to '0' if the frame was received over the MII.
[10]	Reception halted (MRxHalted)	This bit is set if the MRxEn bit is cleared or the MHaltImm bit is set.
[11]	Control frame received (MCtlRecd)	This bit is set if the frame received is a MAC control frame (type = 0x8808), if the CAM recognizes the frame address, and if the frame length is 64 bytes.
[31:12]	Reserved	Not applicable.

7.4.2.8 MAC Station Management Data Register

Table 7-22. STADATA Register

Registers	Address	R/W	Description	Reset Value
STADATAA	0xF00B0018	R/W	Station management data	0x00000000
STADATAB	0xF00D0018	R/W	Station management data	0x00000000

Bit Number	Bit Name	Description
[15:0]	Station management data.	This register contains a 16-bit data value for the station management function.

7.4.2.9 MAC Station Management Data Control and Address Register

The MAC controller provides support for reading and writing station management data to the PHY. Setting options in station management registers does not affect the controller. Some PHYs may not support the option to suppress preambles after the first operation.

Table 7-23. STACON Register

Registers	Address	R/W	Description	Reset Value
STACONA	0xF00B001C	R/W	Station management control and address	0x00006000
STACONB	0xF00D001C	R/W	Station management control and address	0x00006000

Bit Number	Bit Name	Description
[4:0]	PHY register address (MPHYRegAddr)	A 5-bit address, contained in the PHY, of the register to be read or written.
[9:5]	PHY address (MPHYaddr)	The 5-bit address of the PHY device to be read or written.
[10]	Write (MPHYwrite)	To initiate a write operation, set this bit to '1'. For a read operation, clear it to '0'.
[11]	Busy bit (MPHYbusy)	To start a read or write operation, set this bit to '1'. The MAC controller clears the Busy bit automatically when the operation is completed.
[12]	Reserved	Not applicable
[15:13]	MDC clock rate (MMDCrate)	Controls the MDC period. The default value is '011'. MDC period = $MMDCrate \times 4 + 32$ Example) MMDCrate = 011, MDC period = $44 \times (1/\text{system clock})$
[31:16]	Reserved	Not applicable.

7.4.2.10 CAM Enable Register

The CAMEN register indicates which CAM entries are valid, using a direct comparison mode. Up to 21 entries, numbered 0 through 20, may be active, depending on the CAM size. If the CAM is smaller than 21 entries, the higher bits are ignored.

Table 7-24. CAMEN Register

Registers	Address	R/W	Description	Reset Value
CAMENA	0xF00B0028	R/W	CAM enable	0x00000000
CAMENB	0xF00D0028	R/W	CAM enable	0x00000000

Bit Number	Bit Name	Description
[20:0]	CAM enable	Set the bits in this 21-bit value to selectively enable CAM locations 20 through 0. To disable a CAM location, clear the appropriate bit.
[31:21]	Reserved	Not applicable.

7.4.2.11 MAC Missed Error Count Register

The value in the missed error count register, MISSCNT, indicates the number of frames that were discarded due to various type of errors. Together with status information on frames transmitted and received, the missed error count register and the two pause count registers provide the information required for station management.

Reading the missed error bits counter register clears the register. It is then the responsibility of software to maintain a global count with more bits of precision.

The counter rolls over from 0x7FFF to 0x8000 and sets the corresponding bit in the MAC control register. It also generates an interrupt if the corresponding interrupt enable bit is set. If station management software wants more frequent interrupts, you can set the missed error count register to a value closer to the rollover value of 0x7FFF. For example, setting a register to 0x7F00 would generate an interrupt when the count value reaches 256 occurrences.

Table 7-25. MISSCNT Register

Registers	Address	R/W	Description	Reset Value
MISSCNTA	0xF00B003C	R(Clr)/W	Missed error count	0x00000000
MISSCNTB	0xF00D003C	R(Clr)/W	Missed error count	0x00000000

Bit Number	Bit Name	Description
[15:0]	Missed error count (MissErrCnt)	The number of valid packets rejected by the MAC unit because of MAC Rx FIFO overflows, parity errors, or because the MRxEn bit was cleared. This count does not include the number of packets rejected by the CAM.
[31:16]	Reserved	Not applicable.

7.4.2.12 MAC Received Pause Count Register

The received pause count register, PZCNT, stores the current value of the 16-bit received pause counter.

Table 7-26. PZCNT Register

Registers	Address	R/W	Description	Reset Value
PZCNTA	0XF00B0040	R	Pause count	0x00000000
PZCNTB	0XF00D0040	R	Pause count	0x00000000

Bit Number	Bit Name	Description
[15:0]	Pause count received	The count value indicates the number of time slots the transmitter was paused due to the receipt of control pause operation frames from the MAC.

7.4.2.13 MAC Remote Pause Count Register

Table 7-27. RMPZCNT Register

Registers	Address	R/W	Description	Reset Value
RMPZCNTA	0xF00B0044	R	Remote pause count	0x00000000
RMPZCNTB	0xF00D0044	R	Remote pause count	0x00000000

Bit Number	Bit Name	Description
[15:0]	Remote pause count	The count value indicates the number of time slots that a remote MAC was paused as a result of its sending control pause operation frames.

7.4.2.14 Content Addressable Memory (CAM) Register

There are 21 CAM entries for the destination address and the pause control frame. For the destination address CAM value, one destination address consists of 6 bytes. Using the 32-word space (32×4 bytes), you can therefore maintain up to 21 separate destination addresses.

You use CAM entries 0, 1, and 18 to send pause control frames. To send a pause control frame, you write the CAM0 entry with the destination address, the CAM1 entry with the source address, and the CAM 18 entry with length/type, opcode, and operand. You then set the send pause bit in the MAC transmit control register.

Table 7-28. CAM Register

Registers	Address	R/W	Description	Reset Value
CAMA	0xF00B0080-0xF00B00FC	R/W	CAM content (32-word)	Undefined
CAMB	0xF00D0080-0xF00D00FC	R/W	CAM content (32-word)	Undefined

Bit Number	Bit Name	Description
[31:0]	CAM content	The CPU uses the CAM content register as data for destination address. To activate the CAM function, you must set the appropriate enable bits in CAM enable register.

7.5 ETHERNET OPERATIONS

7.5.1 MAC FRAME FORMAT

Table 7-29 lists the eight fields in a standard (IEEE 802.3/Ethernet frame).

Table 7-29. MAC Frame Format Description

Field Name	Field Size	Description
Preamble	7-byte	The bits in each preamble byte are 10101010, transmitted from left to right.
Start frame delimiter (SFD)	1-byte	The SFD bits are 10101011, transmitted from left to right.
Destination address	6-byte	The destination address can be an individual address or a multicast (or broadcast) address.
Source address	6-byte	The MAC does not interpret the source address bytes. However, to qualify as a valid station address, the first bit transmitted (the LSB of the first byte) must be a '0'.
Length or type	2-byte	The MAC treats length fields greater than 1500-byte as type fields. Byte values less than or equal to 1500 indicate the number of logical link control (LLC) data bytes in the data field. The MAC transmits the high-order byte first.
Logical link control (LLC) data	46 to 1500-byte	Data bytes used for logical link control.
PAD	0 to 46-byte	If the LLC data is less than 46-byte long, the MAC transmits pad bytes of all zeros.
Frame check sequence (FCS)	4-byte	The FCS field contains a 16-bit error detection code that is computed as a function of all fields except the preamble, the SFD, and the FCS itself. The FCS - 32 polynomial function is as follows: ' $X^{32} + X^{26} + X^{23} + X^{22} + X^{16} + X^{12} + X^{11} + X^{10} + X^8 + X^7 + X^5 + X^4 + X^2 + X^1 + 1$ '.

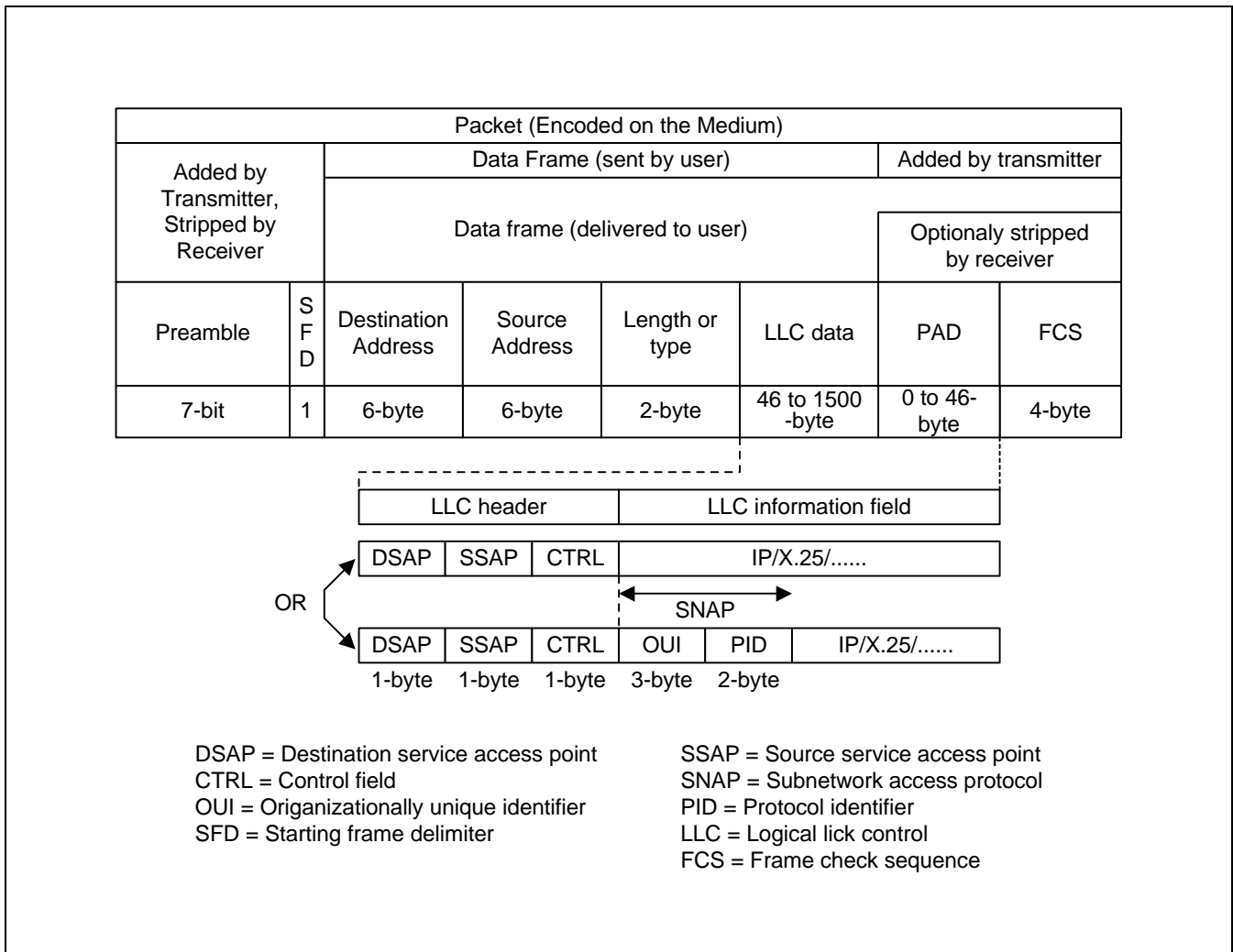

Figure 7-5. Fields of an IEEE802.3/Ethernet Frame

7.5.1.1 Options That Affect the Standard MAC Frame

- There are a number of factors and options that can affect the standard MAC frame, as described in Table 7-2:
- Some PHYs may deliver a longer or shorter preamble.
- Short frame mode permits LLC data fields with less than 46 bytes. Options are available to suppress padding and to support the reception of short frames.
- Long frame mode supports LLC data fields with more than 1500 bytes. An option is also available to support to reception of long frames.
- 'No CRC' mode suppresses the appending of a CRC field.
- 'Ignore CRC' mode allows the reception of frames without valid CRC fields.

7.5.1.2 Destination Address Format

Bit 0 of the destination address is an address type designation bit. It identifies the address as either an individual or a group address. Group addresses are sometimes called 'multicast' addresses and individual addresses are called 'unicast' addresses. The broadcast address is a special group address in the special hex format: FF-FF-FF-FF-FF-FF.

Bit 1 of the destination address distinguishes between locally or globally administered addresses. For globally administered or universal (U) addresses, the bit value is '0'. If an address is to be assigned locally, you must set this bit to '1'. For the broadcast address, this bit must also be set to '1'.

7.5.1.3 Transmitting a Frame

To transmit a frame, the transmit enable bit in the transmit control register must be set and the transmit halt request bit must be zero. In addition, the halt immediate and halt request bits in the MAC control register must be '0'. These conditions are normally set after any BDMA controller initialization has occurred.

The transmission state machine starts transmitting the data in the FIFO, and will retain the first 64 bytes until after this station has acquired the net. At that time, the transmitter requests more data and transmits it until the signalling the end of data to be transmitted. The transmitter appends the calculated CRC to the end of the frame.

A frame transmit operation can be subdivided into two operations,

1) MII transmit interface operation, and 2) BDMA/ MAC transmit interface operation.

7.5.1.3.1. MII Transmit Operation

The transmitter block consists of three state machines: the gap-ok state machine, the back-off state machine, and the main transmission state machine.

The gap-ok state machine

The gap-ok state machine tracks and counts the inter-gap timing between the frames. When not operating in full-duplex mode, it counts 96 bit times from the de-assertion of the carrier sense (CrS) signal. If there is any traffic within the first 64 bit times, the gap-ok state machine reset itself and starts counting from zero.

If there is any traffic in the last 1/3 of the inter-frame gap, the gap-ok state machine continues counting. Following a successful transmission, a gap-ok is sent at the end of the next 96-bit times, regardless of the network traffic.

In full-duplex mode, the gap-ok state machine starts counting at the end of the transmission and the gap-ok signal is sent at the end of the 96 bit times, regardless of the network traffic.

The back-off state machine

The back-off state machine implements the back-off and retry algorithm of the 802.3 CSMA/CD. When a collision is detected, the main transmission state machine starts the back-off state machine's counters and waits for the back-off time (including zero) to elapse. This time is a multiple of 512 bit times that elapse before the frame that caused the collision is re-transmitted.

Each time there is a collision (for one single frame), the back-off state machine increments an internal retry attempt counter. An 11-bit pseudo random number generator outputs a random number by selecting a subset of the value of the generator at any time. The subset is incremented by one bit for each subsequent attempt. This implementation is represented by the following equation:

$$0 \leq \text{random integer}(r) < 2^k$$

$$K = \min(n, \text{back-off limit} (= 10))$$

'r' is the number of slot times the MAC must wait in case of a collision, and 'n' is the number of retry attempts.

For example, after the first collision, 'n' is 1 and 'r' is a random number between 0 and 1. The pseudo random generator in this case is one-bit wide and gives a random number of either 0 or 1. After the second attempt, 'r' is a random number between 0 and 3. Therefore, the state machine looks at the two least-significant bits of the random generator (n = 2), which gives a value between 0 and 3.

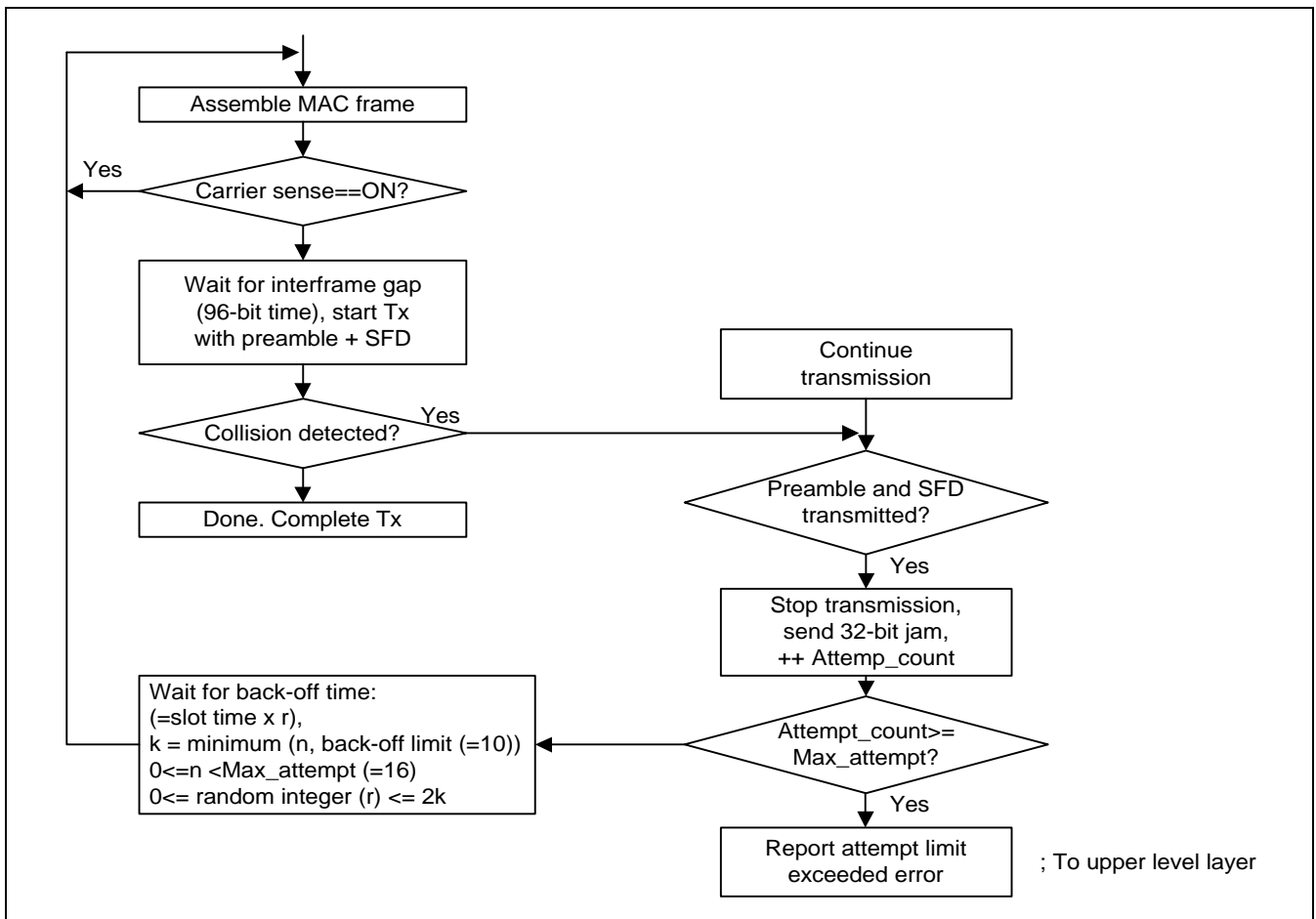

Figure 7-6. CSMA/CD Transmit Operation

The main transmission state machine

The main transmission state machine implements the remaining MAC layer protocols. If there is data to be transferred, if the inter-frame gap is valid, and if the MII is ready (that is, if there are no collisions and no CRS in full-duplex mode), the transmitter block then transmits the preamble followed by the SFD.

After the SFD and preamble are transmitted, the block transmits 64-byte data, regardless of the frame length, unless short transmission is enabled. This means that if the frame is less than 64-byte, it will pad the LLC data field with zeros. It will also append the CRC to the end of the frame, if CRC generation is enabled.

If there is any collision during this first 72-byte time (8-byte preamble and SFD, and 64-byte frame), the main transmission state machine stops the transmission and transmits a jam pattern (32-bit 1's). It then increments the collision attempt counter, returns control to the back-off state machine, and re-transmits the frame when the back-off time has elapsed and the gap time is valid.

If there are no collisions, the transmitter block transmits the rest of the frame. At this time (that is, after the first 60-byte have been transmitted without collisions), the main transmission state machine lets the BDMA engine overwrite the frame. After it transmits the first 64-byte, the transmitter block transmits the rest of the frame, appending the CRC to the end. Parity errors, FIFO errors, or more than 16 collisions will force the transmission state machine to abort the frame (no retry) and to transmit the next frame.

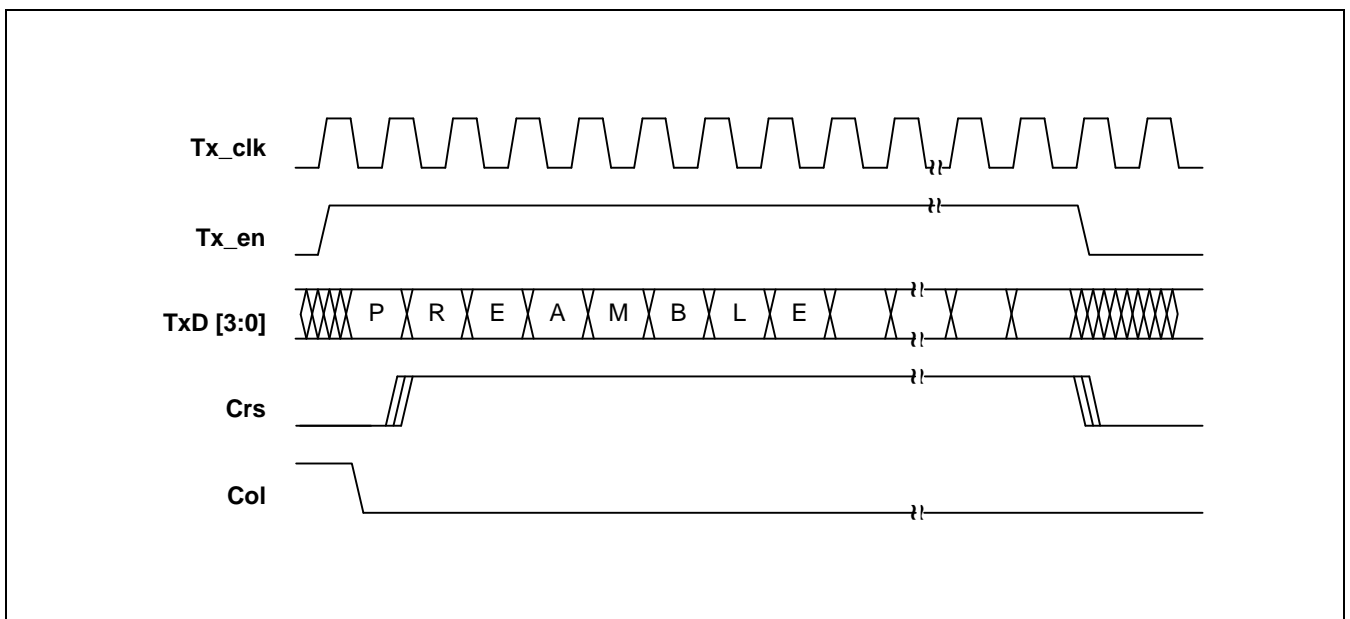

Figure 7-7. Timing for Transmission without Collision

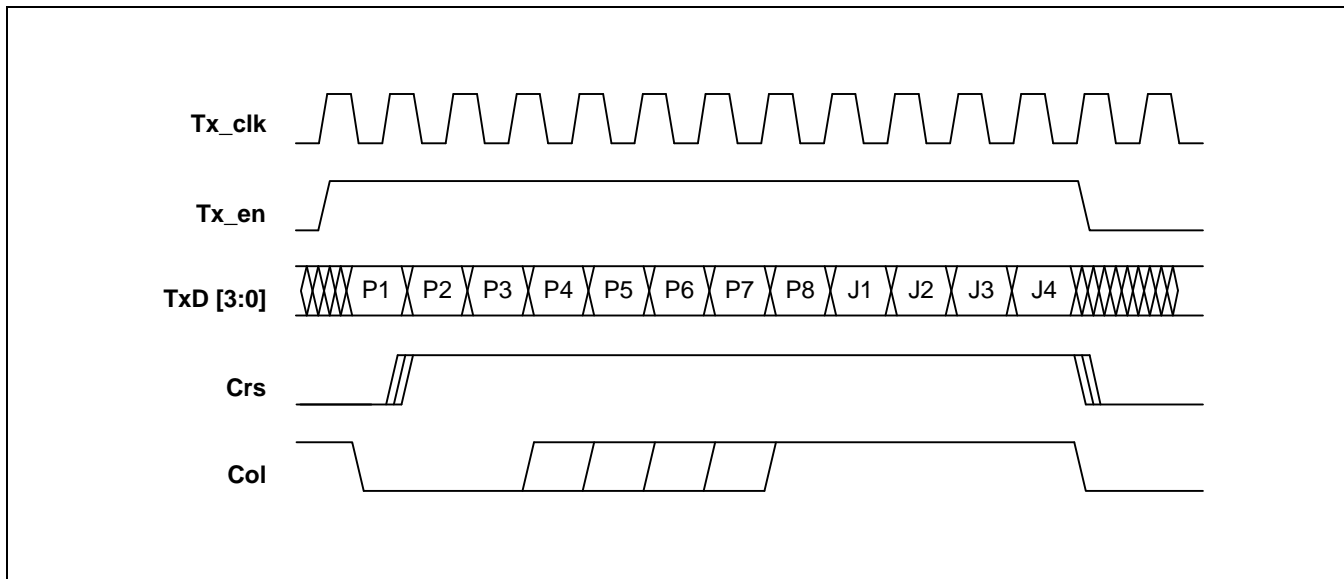

Figure 7-8. Timing for Transmission with Collision in Preamble

7.5.1.3.2. BDMA/MAC Interface Operation for Transmission

The BDI transmit operation is a simple FIFO mechanism. The BDMA engine stores data to be transmitted, and the transmission state machine empties it when the MAC successfully acquires the net.

Note that the two time domains intersect at the FIFO controller. The writing and reading of data is asynchronous and on different clocks. Reading is driven by either a 25MHz or a 2.5MHz TX_CLK. Writing is driven by system clock, which is asynchronous to TX_CLK.

After a reset, the MTxFIFO is empty. To enable the transmission, the system must set the transmit enable bit in the MACTXCON register. In addition, eight bytes of data must be present in the MTxFIFO. The BDMA engine can start stuffing data into the MTxFIFO and then enable the transmit bit. (or it can enable the transmit bit first and then start stuffing data into the MTxFIFO) The transmitting operation can only start if both of these conditions are met.

7.5.1.4. Receiving a Frame

The receiver block, when enabled, constantly monitors a data stream coming either from the MII or, in loop-back mode, from the transmitter block. The MII supplies from zero to seven bytes of preamble, followed by the start frame delimiter (SFD). The receiver block checks that the first nibbles received are preamble, and then looks for the SFD (10101011) in the first 8-byte. If it does not detect the SFD by then, it treats the frame as a fragment and discards it.

The first nibble of destination address follows the SFD, LSB first. When it has received a byte, the receiver block generates parity, stores the byte with its parity in the MRxFIFO. It combines subsequent nibbles into bytes and stores them in the FIFO.

7.5.1.4.1. Receive Frame Timing With/Without Error

If, during frame reception, both Rx_DV and Rx_er are asserted, a CRC error is reported for the current packet.

As each nibble of the destination address is received, the CAM block attempts to recognize it. After receiving the last destination address nibble, if the CAM block rejects the packet, the receive block asserts the Rx_toss signal, and discards any bytes not yet removed from the receive FIFO that came from the current packet. If this operation leaves the FIFO empty, it drops Rx_rdy.

Figure 7-6 shows the MII receive data timing without error. The RX_DV signal, which entered the MII from the PCS layer, will be ON when the PCS layer recovers the Rx_clk from the receive bit stream and delivers the nibble data on RxD[3:0] data line. The RX_DV signal must be ON before the starting frame delimiter (SFD) is received. When the Rx_DV signal is ON, the preamble and SFD parts of the frame header are delivered to MII, synchronized with the 25MHz Rx_clk. (The carrier sense (Crs) signal was turned on during receive frame.)

As its response to the Rx_er signal, the MII immediately inserts an alternative data bit stream into the receive data stream. As a result, the MAC discards this received error frame using the FCS.

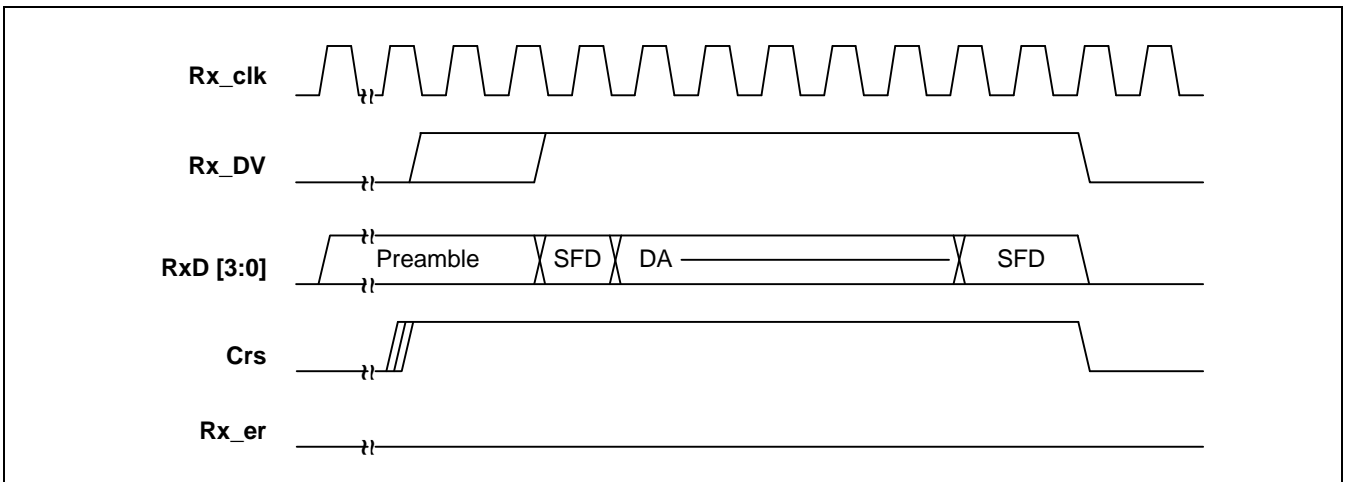

Figure 7-9. Receiving Frame without Error

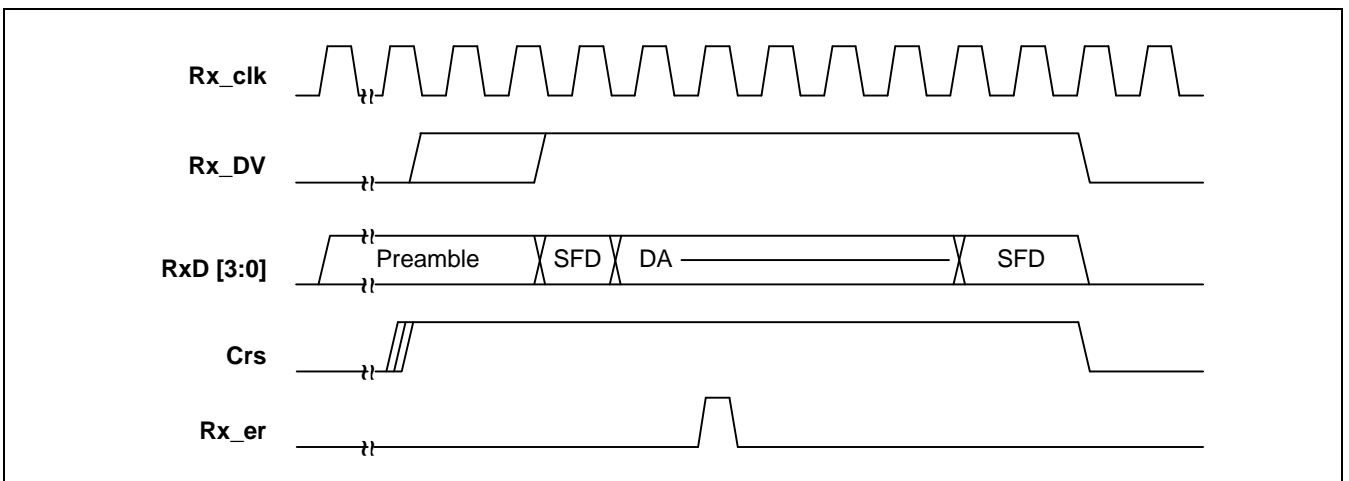

Figure 7-10. Receiving Frame with Error

7.5.1.4.2 BDMA/MAC Interface Operation for Reception

The BDI receive operation is a simple FIFO mechanism. The BDMA engine stores received data to MRxFIFO, and the BDMA RxBUFF controller empties it when the BDMA RxBUFF has enough space left.

Note that the two time domains intersect at the FIFO controller. The writing and reading of data is asynchronous and on different clocks. Reading is driven by system clock, which is asynchronous to RX_CLK. Writing is driven by either a 25MHz or a 2.5MHz RX_CLK.

After a reset, the MRxFIFO is empty. To enable the reception, the system must set the receive enable bit in the MACRXCON register. If the BDMA engine cannot transfer the received data to the BRxBUFF and memory due to the disabled BDMA or the inaccessibility on the system bus, the MAC Rx FIFO may overflow.

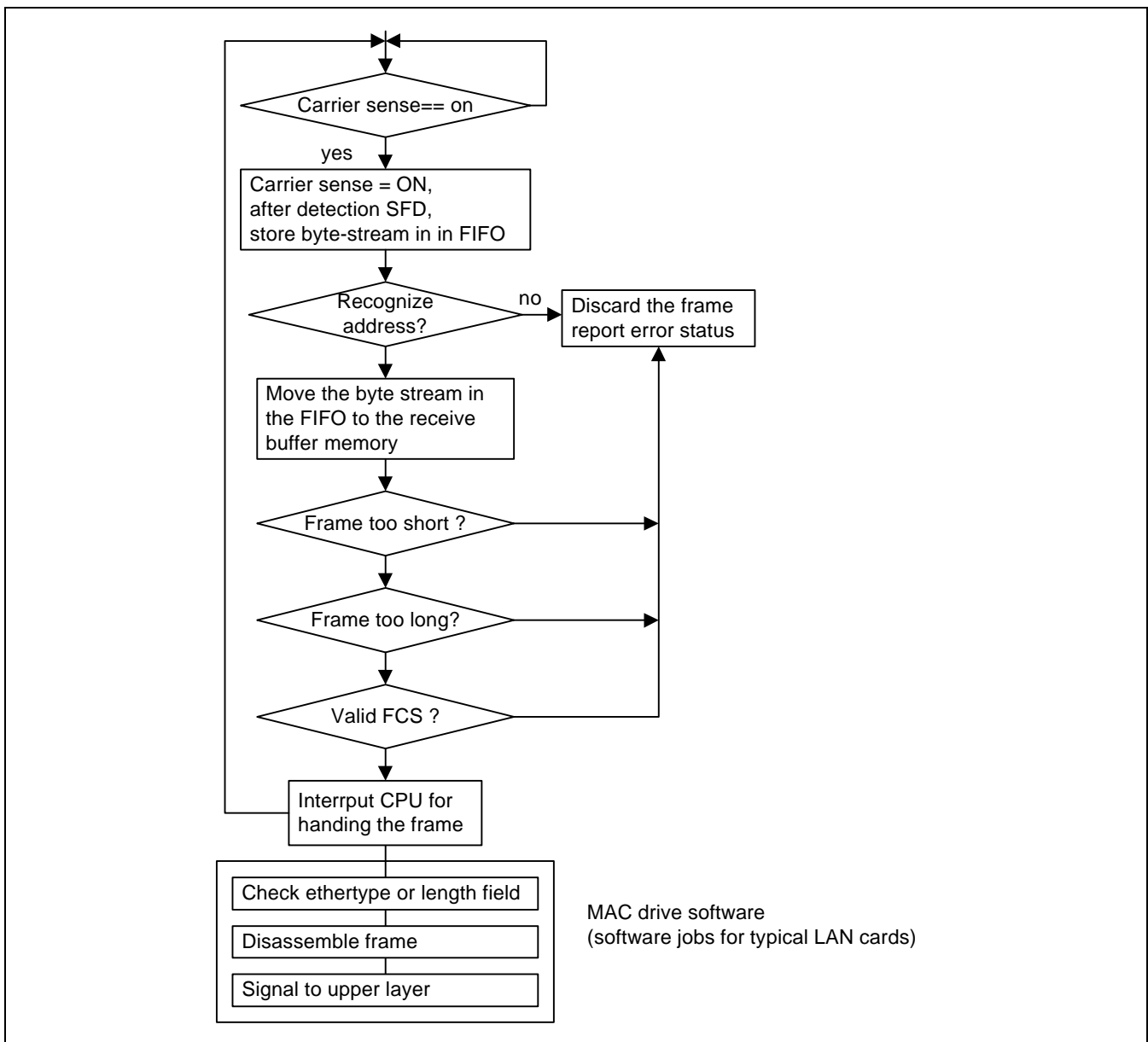

Figure 7-11. CSMA/CD Receive Operation

7.5.2 THE MII STATION MANAGER

The MDIO (management data input/output) signal line is the transmission and reception path for control/status information for the station management entity, STA. The STA controls and reads the current operating status of the PHY layer. The speed of transmit and receive operations is determined by the management data clock, MDC.

The frame structure of the STA that writes command to control registers, or which reads the status register of a PHY device, is shown Table 7-30. The PHY address is defined as the identification (ID) value of the various PHY devices that may be connected to a single MAC. Register addresses can contain the ID value for up to 32 types of PHY registers.

Turn-around bits are used to regulate the turn-around time of the transmit/receive direction between the STA and a PHY device. So that the STA can read the set value of a PHY device register, it must transmit the frame data, up to a specific register address, to the PHY device. During the write time (which is an undirected transmission), the STA transmits a stream of turn-around bits. As a result, by transmitting a write or read message to a PHY device through the MDIO, the STA can issue a request to set the operation or to read the operation status.

As its response this message, the PHY device resets itself, sets loop-back mode, selects active/non-active auto-negotiation process, separates the PHY and MII electrically, and determines whether or not to activate the collision detection process.

When it receives a read command, the PHY reports the type of PHY device such as 100 base-T4, FDX 100 base-X, HDX 100Base-X, 10M-b/s FDX, or 10M-b/s HDX.

Table 7-30. STA Frame Structure Description

	Preamble	Start of Frame	Operation Code	PHY Address	Register Address	Turnaround	Data	Idle
Write (Command)	11111111 (32 bits)	01	01 (write)	5 bits	5 bits	10 (2 bits)	16 bits (register value)	Z
Read (Status)	11111111 (32 bits)	01	10 (read)	5 bits	5 bits	Z0	16 bits (register value)	Z
Direction: STA to PHY						Direction: PHY to STA		

7.5.3 FULL-DUPLEX PAUSE OPERATIONS

Flow control can be done by the use of control frames. The receive logic in the flow control block recognise a MAC control frame as follows:

- The current specification for full-duplex flow control specifies a special destination address for the Pause operation frame. In order for the MAC to receive frames that contain this special destination address, the address must be programmed in one of the CAM entries. This CAM entry must then be enabled, and the CAM activated. Some CAM entries are also used when generating a flow control frame using the MSdPause bit in the MACTXCON register.
- The length/type field is a 2-octet field that shall contain the hexadecimal value: 88-08. The frame length must be at least 64 bytes, including CRC. The CRC must be valid, and the frame must contain a valid pause opcode and a parameter (pause period) field. If the length/type field does not have the special value specified for MAC control frames, the MAC takes no action, and the frame is treated as a normal frame. If the frame is marked as a MAC control frame and pass-through is enabled, it is passed to the software drivers.

User can set the control bit in the MAC control register to generate a Full-Duplex pause operation or other MAC control functions, even if the transmitter itself is paused.

The command and status registers initiate the sending of a MAC control frame, enable and disable MAC control functions, and read the values of the flow control counters.

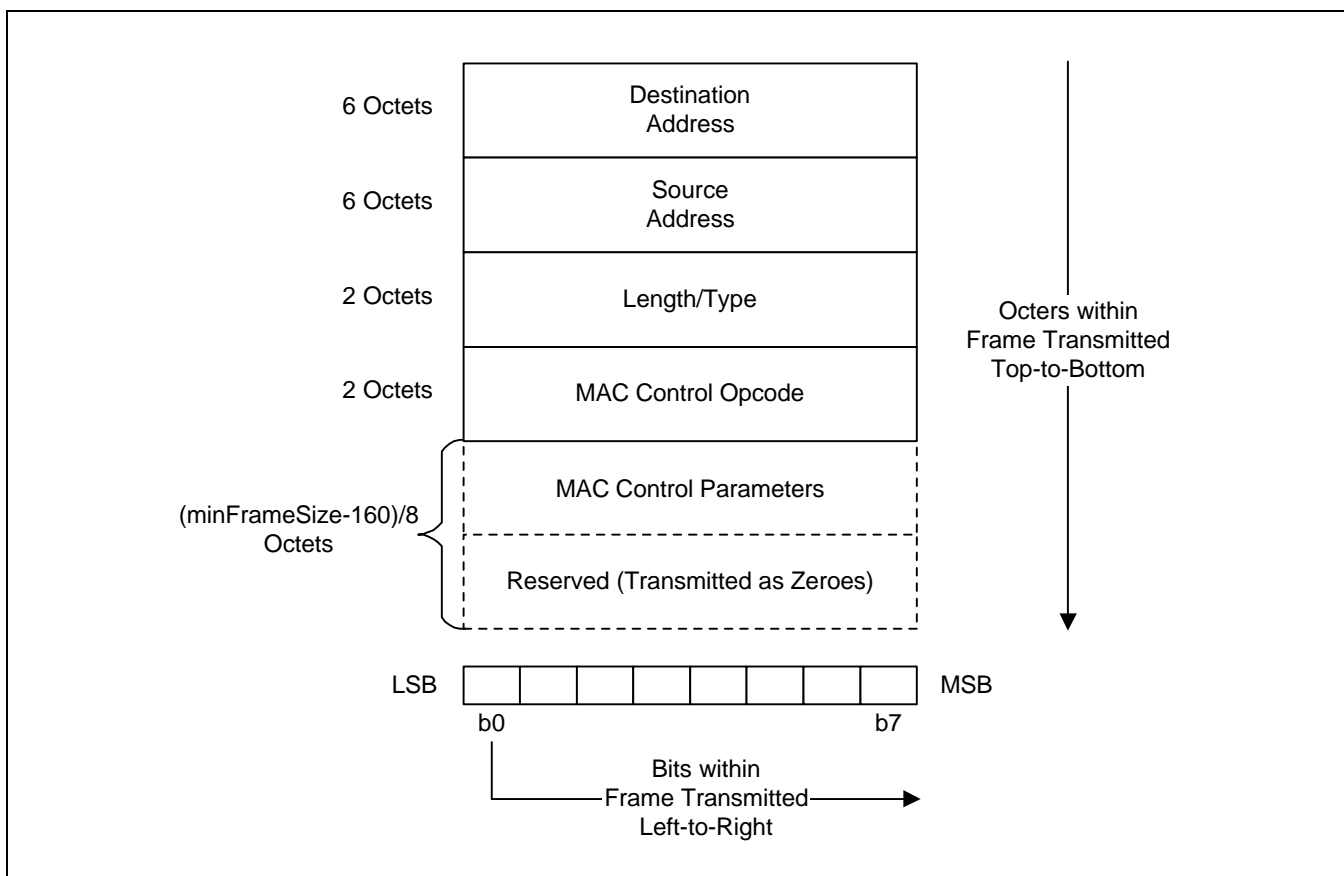

Figure 7-12. MAC Control Frame Format

7.5.3.1 Transmit Pause Operation

To enable a full-duplex Pause operation, the special broadcast address for MAC control frames must be programmed into the CAM, and the corresponding CAM enable bit set. The special broadcast address can be a CAM location. To optimize the utilization CAM entries, you can specify a preference for specific CAM locations. This feature is described below.

The MAC receive circuit recognizes a full-duplex Pause operation when the following conditions are met:

- The length/ type field has the special value for MAC control frames, 0x8808.
- The CAM detects the correcting destination address.
- The length of the frame is 64 bytes.
- The receiving CRC is correct.
- The operation field specifies a Pause operation.

When a full-duplex pause operation is recognized, the MAC receive circuit loads the operand value into the pause count register. It then signals both the MAC and the BDMA engine that the pause should begin at the end of the current frame, if any.

The pause circuit maintains the pause counter, and decrements it to zero. It does this before it signals the end of the pause operation, and before allowing the transmit circuit to resume its operation.

If a second full-duplex pause operation is recognized while the first operation is in effect, the pause counter is reset with the current operand value. Note that a count value of zero may cause pre-mature termination of a pause operation that is already in progress.

7.5.3.2 Remote Pause Operation

To send a remote pause operation, follow these steps:

1. Program CAM location 0 with the destination address.
2. Program CAM location 1 with the source address.
3. Program CAM location 18 with length/type field, opcode, and operand.
4. Program the 2 bytes that follow the operand with 0000H.
5. Program the three double words that follow CAM location 18 with zeros.
6. Write the transmit control register to set the MSdPause bit.

The destination address and source address are commonly used as the special broadcast address for MAC control frames and the local station address, respectively. To support future uses of MAC control frames, these values are fully programmable in the flow control 100/10M-bps Ethernet MAC.

When the remote Pause operation is completed, the transmit status is written to the transmit control frame status register. The BDMA engine is responsible for providing an interrupt enable control.

7.5.4 ERROR SIGNALLING

The error/abnormal operation flags asserted by the MAC are arranged into transmit and receive groups. These flag groups are located either in the transmit status register (MACTXSTAT) or the receive status register (MACRXSTAT). A missed frame error counter is included for system network management purposes.

Normally, software does not have enough direct control to examine the status registers directly. Therefore, the BDMA engine must store the values in system memory so that they can be examined by software.

7.5.4.1 Reporting of Transmission Errors

A transmit operation terminates when the entire frame (preamble, SFD, data, and CRC) has been successfully transmitted through the MII without a collision. In addition, the transmitter block detects and reports both the internal and the network errors.

Under the following conditions, the transmit operation will be aborted (in most cases).

Parity error	The 8-bit of data incoming through the BDMA has an optional parity bit. A parity bit also protects each byte in the MTxFIFO. If a parity error occurs, the transmission is aborted. A detected parity error sets the TxParErr bit in the BMTXSTAT register.
MTxFIFO Underflow	The 80-byte MTxFIFO can handle a system latency of 640 bit times. An underflow of the MTxFIFO during transmission indicates that the system cannot keep up with the demand of the MAC, and the transmission is aborted.
No Carrier	The carrier sense signal (CrS) is monitored from the beginning of the start of frame delimiter (SFD) to the last byte transmitted. A NoCarr indicates that CrS was never present during transmission (a possible network problem), but the transmission will NOT be aborted. Note that during loop-back mode, the MAC is disconnected from the network, and a 'No CrS' will not be detected.
Excessive collision error	Whenever the MAC encounters a collision during transmit, it will back off, update the 'attempt counter' and retry the transmission later on. When the attempt counter reaches 16 (16 attempts that all resulted in a collision), the transmission is aborted. This indicates a network problem.
Late collision error	Normally, the MAC would detect a collision (if one occurs) within the first 64 bytes of data that are transmitted, including the preamble and SFD. If a collision occurs after this time frame, a possible network problem is indicated. The error is reported to the transmission state machine, but the transmission is NOT aborted. Instead, it performs a back-off, as usual.
Excessive deferral error	During the first attempt to send a frame, the MAC may have to defer the transmission because the network is busy. If this deferral time is longer than 32K-bit times, the transmission is aborted. Excessive deferral errors indicate a possible network problem.

7.5.4.2 Reporting of Reception Errors

When it detects a start of frame delimiter (SFD), the MAC starts putting data it has received from the MII into the MRxFIFO. It also checks for internal errors (MRxFIFO overruns) while reception is in progress.

When the reception process is completed, the MAC checks for external errors, such as frame alignment, length, CRC, and frame too long.

The following is a description of the types of errors that may occur during a receive operation:

Parity error	A parity bit protects each byte in the MRxFIFO. If a parity error occurs, it is reported to the MAC. A detected parity error sets the RxParErr bit in the BMRXSTAT register.
Frame Alignment Error	After receiving a frame, the receiver block checks that the incoming frame (including CRC) was correctly framed on an 8-bit boundary. If it is not and if the CRC is invalid, data has been disrupted through the network, and the receive block reports a frame alignment error. A CRC error is also reported.
CRC Error	After receiving a frame, the receiver block checks the CRC for validity, and reports a CRC error if it is invalid. The PHY informs the MAC if it detects a medium error (such as a coding violation) by asserting the input pin RX_ER. When the MAC sees RX_ER asserted, it sets CRCErr bit of the BMRXSTAT register.
Frame too long	<p>The receiver block checks the length of the incoming frame at the end of reception (including CRC, but excluding preamble and SFD). If the length is longer than the maximum frame size of 1518 bytes, the receiver block reports receiving a 'long frame', unless long frame mode is enabled. The receiver can detect network-related errors such as CRC, frame alignment, and length errors. It can also detect these types of errors in the following combinations:</p> <ul style="list-style-type: none">— CRC errors only— Frame alignment and CRC errors only— Length and CRC errors only— Frame alignment, length, and CRC errors
MRxFIFO full	During the reception, the incoming data are put into the MRxFIFO temporarily before they are transferred to the system memory. If the MRxFIFO is filled up because of excessive system latency or for other reasons, the receiver block sets the overrun bit in the BMRXSTAT register.
MII error	The PHY informs the MAC if it detects a medium error (such as a coding violation) by asserting the input pin Rx_er. When the MAC sees Rx_er asserted, it sets CRCErr bit of the receive status register.

7.5.5 TIMING PARAMETERS FOR MII TRANSACTIONS

The timing diagrams in this section conform to the guidelines described in the "Draft Supplement to ANSI/IEEE Std. 802.3, Section 22.3, Signal Characteristics."

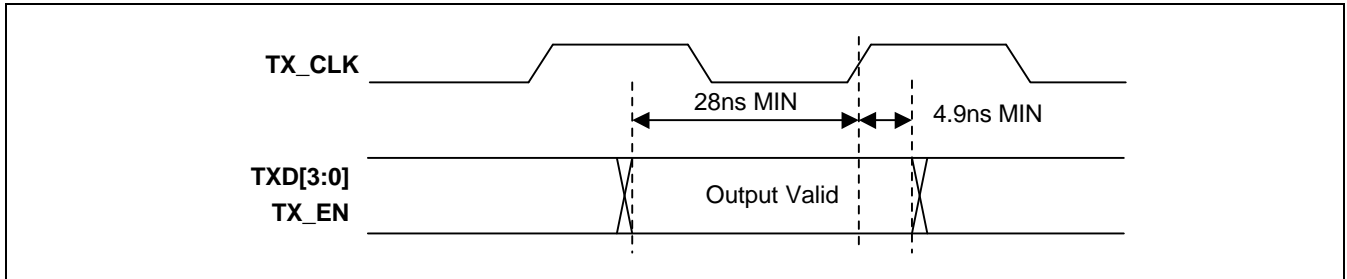

Figure 7-13. Timing Relationship of Transmission Signals at MII

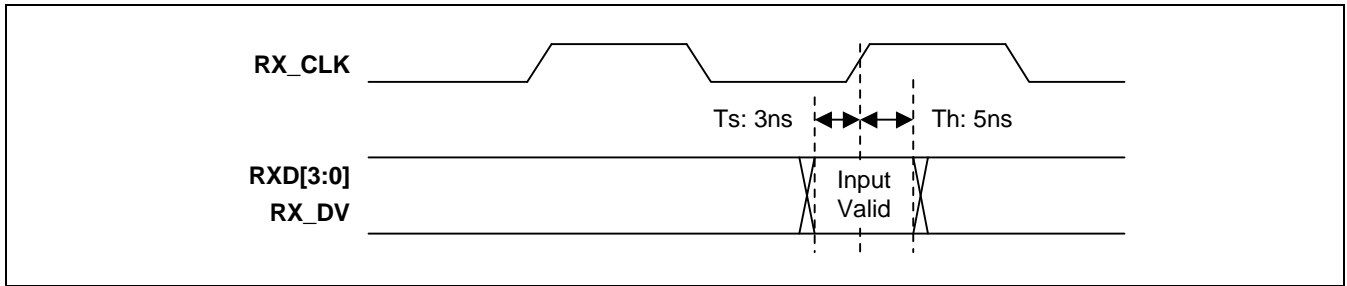

Figure 7-14. Timing Relationship of Reception Signals at MII

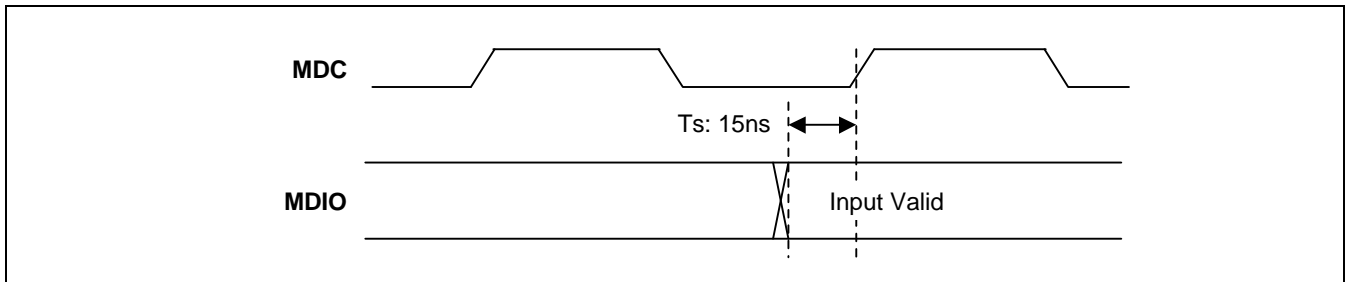

Figure 7-15. MDIO Sourced by PHY

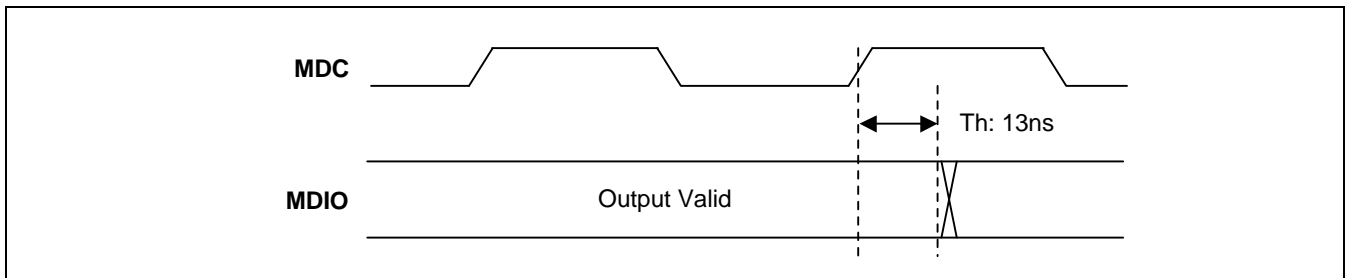

Figure 7-16. MDIO Sourced by STA

8

DES/3DES

8.1 OVERVIEW

The Data Encryption Standard (DES) consists of the Data Encryption Algorithm (DES) and Triple Data Encryption Algorithm (TDEA, as described in ANSI X9.52). The DES/3DES accelerator of the S3C2501X is designed in such a way that they may be used in a computer system or network to provide cryptographic protection to binary coded data.

FIPS PUB 81, DES Modes of operation, describes four different modes for using DES described in this standard. Those are ECB-electronic codebook, CBC-cipher block chaining, CFB-cipher feedback, and OFB-output feedback. But in the S3C2501X, two modes are supported – ECB and CBC.

The X9.52 standard, "Triple Data Encryption Algorithm Modes of Operation" describes seven different modes for using TDEA. Those are TECB – TDEA electronic codebook mode of operation, TCBC – TDEA cipher block chaining mode of operation, TCBC-I – TDEA cipher block chaining mode of operation-interleaved, TCFB – TDEA cipher feedback mode of operation, TCFB-P – TDEA cipher feedback mode of operation-pipelined, TOFB – TDEA output feedback mode of operation, and TOFB-I – TDEA output feedback mode of operation-interleaved. But in the S3C2501X, two modes are supported-TECB and TCBC.

8.2 FEATURES

- DES or Triple DES Mode
- ECB or CBC Mode
- Encryption or Decryption Support
- General DMA Support

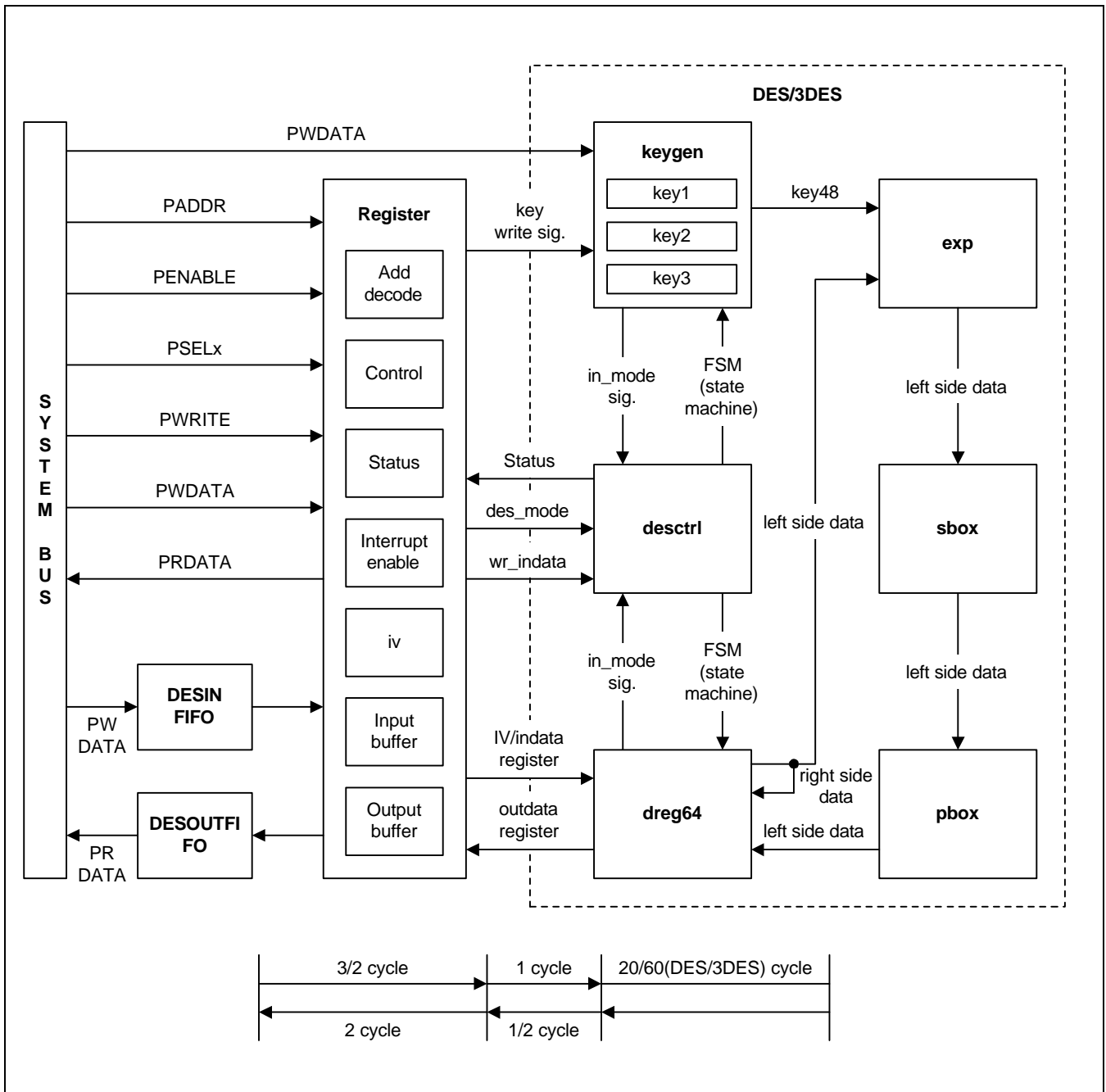

Figure 8-1. DES/3DES Block Diagram

8.3 DES/3DES SPECIAL REGISTERS

Table 8-1. DES/3DES Special Registers Overview

Registers	Address	R/W	Description	Reset Value
DESCON	0xF0090000	R/W	DES/3DES control register	0x00000000
DESSTA	0xF0090004	R	DES/3DES status register	0x00000231
DESINT	0xF0090008	R/W	DES/3DES interrupt enable register	0x00000000
DESRUN	0xF009000C	W	DES/3DES run enable register	0x00000000
DESKEY1L	0xF0090010	R/W	Key 1 left half. *Key 1 is the security key for DES, the 1 st DES of 3DES in the encryption mode or 3 rd DES of 3DES in the decryption mode.	0x00000000
DESKEY1R	0xF0090014	R/W	Key 1 right half	0x00000000
DESKEY2L	0xF0090018	R/W	Key 2 left half. *Key 2 is the security key for the 2 nd DES of 3DES.	0x00000000
DESKEY2R	0xF009001C	R/W	Key 2 right half	0x00000000
DESKEY3L	0xF0090020	R/W	Key 3 left half. *Key 3 is the security key for the 3 rd DES of 3DES in the encryption mode or 1 st DES of 3DES in the decryption mode.	0x00000000
DESKEY3R	0xF0090024	R/W	Key 3 right half	0x00000000
DESIVL	0xF0090028	R/W	IV left half. *IV is used for CBC mode only. The IV for the next block is updated automatically.	0x00000000
DESIVR	0xF009002C	R/W	IV right half	0x00000000
DESINFIFO	0xF0090030	W	DES/3DES input FIFO This FIFO depth is 8 words.	0xFFFFFFFF
DESOUTFIFO	0xF0090034	R	DES/3DES output FIFO This FIFO depth is 8 words.	0xFFFFFFFF

8.3.1 DES/3DES CONTROL REGISTER

Table 8-2. DES/3DES Control Register Description

Bit Number	Bit Name	Description
[0]	Run Enable	0 = DES/3DES disable 1 = DES/3DES enable This bit is the same register as the Run Enable bit of the Run Enable Register. That is, this bit has two writing address, 0x00 and 0x0C.
[1]	Indata_DMA	0 = CPU transfers the data to be encrypted from the external memory to the DESINFIFO of DES/3DES 1 = GDMA transfers the data to be encrypted from the external memory to the DESINFIFO of DES/3DES
[2]	Outdata_DMA	0 = CPU transfers the encrypted data from the DESOUTFIFO of DES/3DES to the external memory 1 = GDMA transfers the encrypted data from the DESOUTFIFO of DES/3DES to the external memory
[3]	Right_Left data	0 = CPU write(read) from left half to right half data in DESINFIFO(out DESOUTFIFO) 1 = CPU write(read) from right half to left half data in DESINFIFO(out DESOUTFIFO)
[4]	Encryption or Decryption	0 = DES/3DES data will be encrypted. 1 = DES/3DES data will be decrypted
[5]	DES or 3DES	0 = DES algorithm is selected 1 = Triple-DES algorithm is selected
[6]	Encryption Mode (ECB or CBC)	0 = DES/3DES will be running ECB(Electronic Code Book) mode. 1 = DES/3DES will be running CBC(Cipher Block Chaining) mode.
[7]	2word_req	0 = DES/3DES engine generates Valid DESOUTFIFO bit in the state register when DESOUTFIFO has 4 word valid data 1 = DES/3DES engine generates Valid DESOUTFIFO bit in the state register when DESOUTFIFO has 2 word valid data.
[8]	FIFO Test	0 = Normal operation 1 = DESINFIFO and DESOUTFIFO test. If this bit sets to 1, user can scan DESINFIFO and DESOUTFIFO.
[9]	FIFO Reset	0 = Normal operation 1 = The data in the DESINFIFO and DESOUTFIFO have been invalid data.

8.3.2 DES/3DES STATUS REGISTER

Table 8-3. DES/3DES Status Register Description

Bit Number	Bit Name	Description
[0]	Idle	This bit indicates whether DES/3DES is running or not
[3:1]	Reserved	These bits have 0 value.
[4]	Available DESINFIFO	DESINFIFO is vacant 4 (or 2, depends on DESCON[7]) words or more, this bit is set to 1.
[5]	Empty DESINFIFO	DESINFIFO is vacant all.
[6]	Full DESINFIFO	DESINFIFO has 8 words valid data. CPU can't write in any more.
[7]	Reserved	This bit has 0 value.
[8]	Valid DESOUTFIFO	DESOUTFIFO has 4(or 2, depends on DESCON[7]) valid words or more, this bit is set to 1.
[9]	Empty DESOUTFIFO	DESOUTFIFO is vacant all.
[10]	Full DESOUTFIFO	DESOUTFIFO has 8 words valid data. CPU have to read data immediately.

8.3.3 DES/3DES INTERRUPT ENABLE REGISTER

Table 8-4. DES/3DES Interrupt Enable Register Description

Bit Number	Bit Name	Description
[0]	Int Idle	Interrupt enable register for DES/3DES engine operation 0 = Disable 1 = Interrupt signal is generated when the status register [0] (Idle) bit goes to high which means the end of the current DES/3DES operation.
[3:1]	Reserved	Reserved
[4]	Int Available DESINFIFO	Interrupt enable register for input FIFO, DESINFIFO 0 = Disable 1 = Interrupt signal is generated when the status register [4] (Available DESINFIFO) bit goes to high
[7:5]	Reserved	Reserved
[8]	Int Valid DESOUTFIFO	Interrupt enable register for output FIFO, DESOUTFIFO 0 = Disable 1 = Interrupt signal is generated when the status register [8] (Valid DESOUTFIFO) bit goes to high

8.3.4 DES/3DES RUN ENABLE REGISTER

Table 8-5. DES/3DES Run Enable Register Description

Bit Number	Bit Name	Description
[0]	Run Enable	If you set this bit to 1, DES/3DES engine begin to run. This bit is the same register as the Run Enable bit of the DES/3DES Control Register. You can read this bit by addressing 0x00, too.

8.3.5 DES/3DES KEY1 LEFT/RIGHT SIDE REGISTER

Table 8-6. DES/3DES Key1 Left Side Register Description

Bit Number	Bit Name	Description
[1:32]	Key 1 Left Half	The left half of the Key1 should be stored to this register. The 8 th bit of each byte is parity bit, and it isn't used for encryption/decryption.

Table 8-7. DES/3DES Key 1 Right Side Register Description

Bit Number	Bit Name	Description
[33:64]	Key 1 Right Half	The right half of the Key1 should be stored to this register. The 8 th bit of each byte is parity bit, and it isn't used for encryption/decryption.

8.3.6 DES/3DES KEY 2 LEFT/RIGHT SIDE REGISTER

Table 8-8. DES/3DES Key 2 Left Side Register Description

Bit Number	Bit Name	Description
[1:32]	Key 2 Left Half	The left half of the Key2 should be stored to this register. The 8 th bit of each byte is parity bit, and it isn't used for encryption/decryption.

Table 8-9. DES/3DES Key 2 Right Side Register Description

Bit Number	Bit Name	Description
[33:64]	Key 2 Right Half	The right half of the Key2 should be stored to this register. The 8 th bit of each byte is parity bit, and it isn't used for encryption/decryption.

8.3.7 DES/3DES KEY 3 LEFT SIDE REGISTER

Table 8-10. DES/3DES Key 3 Left Side Register Description

Bit Number	Bit Name	Description
[1:32]	Key 3 Left Half	The left half of the Key3 should be stored to this register. The 8 th bit of each byte is parity bit, and it isn't used for encryption/decryption.

Table 8-11. DES/3DES Key 3 Right Side Register Description

Bit Number	Bit Name	Description
[33:64]	Key 3 Right Half	The right half of the Key3 should be stored to this register. The 8 th bit of each byte is parity bit, and it isn't used for encryption/decryption.

8.3.8 DES/3DES IV LEFT/RIGHT SIDE REGISTER

Table 8-12. DES/3DES IV Left Side Register Description

Bit Number	Bit Name	Description
[1:32]	IV Left Half	IV is only used for the CBC mode. The left half of the 1 st IV should be stored in this register. The IV for the next block is updated in this register automatically.

Table 8-13. DES/3DES IV Right Side Register Description

Bit Number	Bit Name	Description
[33:64]	IV Right Half	IV is only used for the CBC mode. The right half of the 1 st IV should be stored in this register. The IV for the next block is updated in this register automatically.

8.3.9 DES/3DES INPUT/OUTPUT DATA FIFO REGISTER

Table 8-14. DES/3DES Input Data FIFO Description

Bit Number	Bit Name	Description
[31:0]	DESINFIFO	This FIFO can be filled by CPU or DMA (depends on control register value). This FIFO consists of 8 words. If data are transferred by DMA, the 4-word burst transaction (DESCON[7] is zero and DCON#[5] is one) is recommended. Otherwise, if data are transferred by CPU, the 2-word transaction (DESCON[7] is one) is recommended. If DESCON[3] is zero, the 1 st written data is the left half of data to be encrypted/decrypted, bit[1:32]. The second one is the right half of data to be encrypted/decrypted, bit[33:64]. Otherwise, if DESCON[3] is one, the 1 st written data is the right half of data to be encrypted/decrypted, bit[33:64]. The second one is the left half of data to be encrypted/decrypted, bit[1:32].

Table 8-15. DES/3DES Output Data FIFO Description

Bit Number	Bit Name	Description
[31:0]	DESOUTFIFO	This FIFO can be read by CPU or DMA (depends on control register value). This FIFO consists of 8 words. If data are transferred by DMA, the 4-word burst transaction (DESCON[7] is zero and DCON#[5] is one) is recommended. Otherwise, if data are transferred by CPU, the 2-word transaction (DESCON[7] is one) is recommended. If DESCON[3] is zero, the 1 st read data is the left half of data encrypted/decrypted, bit[1:32]. The second one is the right half of data encrypted/decrypted, bit[33:64]. Otherwise, if DESCON[3] is one, the 1 st read data is the right half of data encrypted/decrypted, bit[33:64]. The second one is the left half of data encrypted/decrypted, bit[1:32].

8.4 DES/3DES OPERATION

The 64-bit data to be encoded should be written to DESINFIFO of DES/3DES block by CPU or DMA. When the data conversion is completed, the Valid DESOUTFIFO bit in DESSTA is set to 1 and the CPU/DMA can read the encrypted data from the DESOUTFIFO.

The DESINFIFO and DESOUTFIFO consists of eight 32 bit registers that are used for data storage. The DESINFIFO has two data request options for data transmission, which is controlled by DESCON[7]. When the DESCON[7] is set to "0", the Available DESINFIFO status means that DESINFIFO is empty for 4 word (If is recommended, when DMA mode is selected). When the DESCON[7] is set to "1", the Available DESINFIFO status means that DESINFIFO is empty for 2 word. Similarly, the DESOUTFIFO has two interrupt options for data receiving, which is controlled by DESCON[7]. When the DESCON[7] is set to "0", the Valid DESOUTFIFO status means that DESOUTFIFO has at least 4 word valid data (If is recommended, when DMA mode is selected). When the DESCON[7] is set to "1", the Valid DESOUTFIFO status means that DESOUTFIFO has at least 2 word valid data. When the Available DESINFIFO or Valid DESOUTFIFO request signal (interrupt or DMA signal) is generated, the CPU or DMA can write or read data to/from the DESIN/OUTFIFO.

Software can use DES or 3DES according to applications, which is controlled by DESCON[5]. When the DESCON[5] is set to "0" (the DES algorithm is used), the key1 value is used and the key2 and the key3 are ignored. When the DESCON[5] is set to "1" (the 3DES algorithm is used), the Key1, key2 and key3 value are used. The 3DES algorithm can select the number of keys (2 keys or 3 keys). It must be noticed that when the 3DES with 2 keys (not 3 keys) is selected, the key value of the key1 register and the key3 register must be the same.

8.5 PERFORMANCE CALCULATION GUIDE

Supposed condition:

- DESINFIFO has already data to be encrypting.
- DESOUTFIFO can be written data to be encrypted.

Cycle Unit (Reference Figure 8-1 DES/3DES Block Diagram)

- Unit 1: from DESINFIFO to input buffer (1+1/2 cycle)
- Unit 2: from input buffer to DES engine (1 cycle)
- Unit 3: DES operation (20 cycles for DES, 60 cycles for 3DES)
- Unit 4: from DES engine to output buffer (1/2 cycle)
- Unit 5: from output buffer to DESOUTFIFO (2 cycle)
- total: 25 cycles for DES, 65 cycles for 3DES

Explain: DES engine consumes fixed cycle per block (25 cycles for DES, and 65 cycles for 3DES). If the DES operating frequency is 133MHz and the DES has one block to be encrypted, the DES performance is **341 Mbps** for DES or **131 Mbps** for 3DES. For more real system condition, the user have to consider how many cycles is needed for external memory access. The memory access cycle should be included the performance calculation as follows

DES Performance Calculation Formula

$$P = (\text{\#num of block} \times 64 \text{ bit}) / \{(\text{time of one period}) \times [(\text{\#num of block} \times C_{\text{des}}) + (C_{\text{mem2des}} + C_{\text{des2mem}})]\}$$

- time of one period: 7.5 ns if operating frequency is 133 MHz
- C_{des} : 25 for DES, 65 for 3DES
- C_{mem2des} : the cycle from external memory to DESINFIFO
- C_{des2mem} : the cycle from DESOUTFIFO to external memory

9

GDMA CONTROLLER

9.1 OVERVIEW

The S3C2501X has a six-channel General DMA controller, called the GDMA. The six-channel GDMA performs the following data transfers without CPU intervention:

- Memory-to-Memory (Memory to/from Memory)
- External Device-to-Memory (External Device to/from Memory)
- HUART-to-Memory (High-speed UART to/from Memory)
- DES-to-Memory (DES to/ from Memory)

The on-chip GDMA can be started by software and/or an external GDMA request (xGDMA_Req), HUART request, or DES request. Software can also be used to restart a GDMA operation after it has been stopped.

The CPU can recognize when a GDMA operation has been completed by software polling and/or when it receives an appropriate internally generated GDMA interrupt. The S3C2501X GDMA controller can increment or decrement source destination addresses and conduct 8-bit (byte), 16-bit (half-word) or 32-bit (word) data transfer.

The GDMA does not check the cache coherency. So software must ensure that source and destination addresses must be configured as non-cacheable in the memory system configuration when it configures the GDMA channels.

The local priority of six-channel GDMA can be programmed by fixed priority or round-robin priority in similar manner to the AHB bus priority. Please refer to Chapter 4, The System Configuration.

9.2 FEATURE

- Six GDMA Channels
- Memory to Memory Data Transfer
- Memory to Peripheral Data Transfer (High Speed UART, DES)
- Support for Four External GDMA Request from GDMA Request Pins (xGDMA_Req0 – xGDMA_Req3)

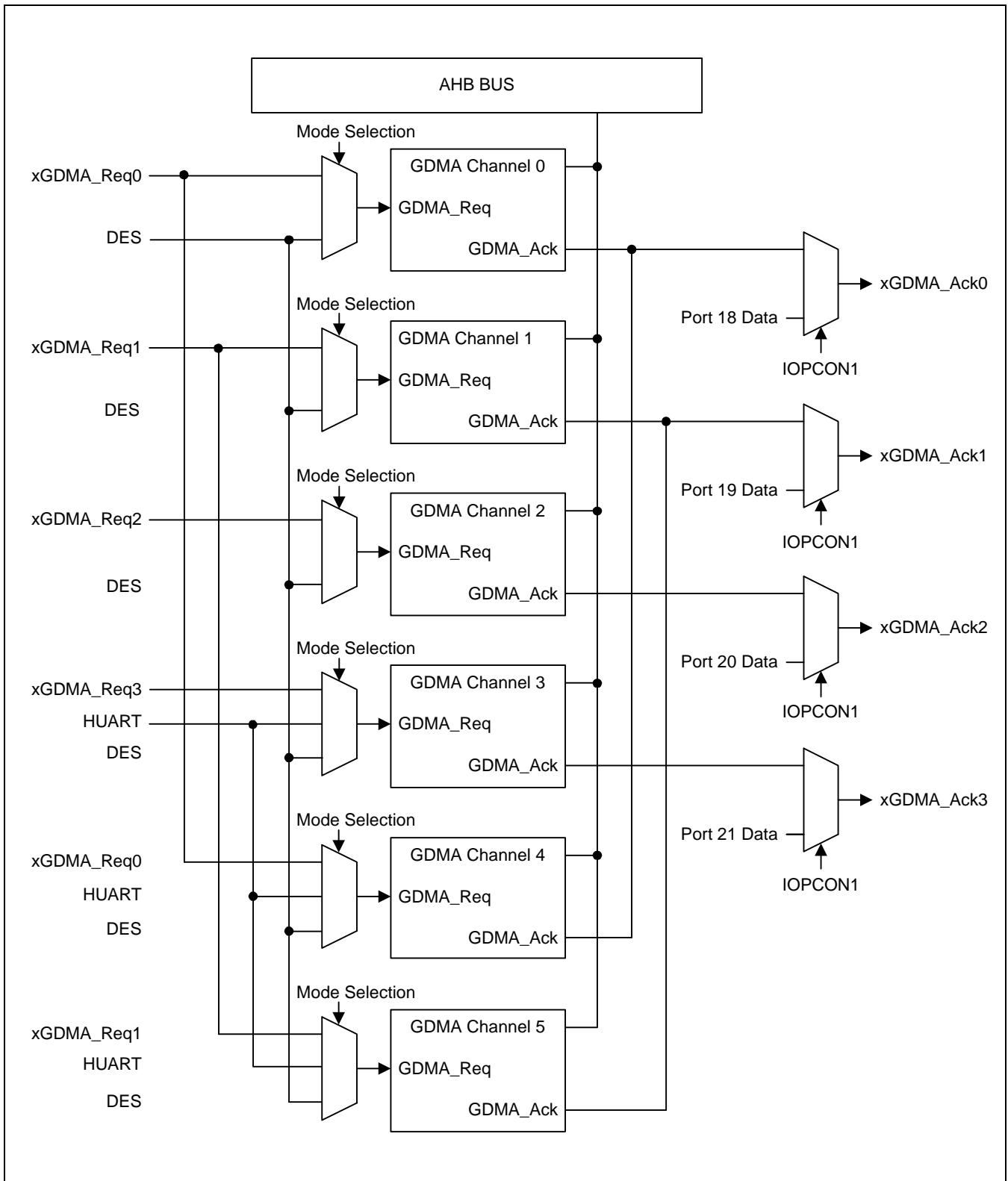

Figure 9-1. GDMA Controller Block Diagram

9.3 GDMA SPECIAL REGISTERS

Table 9-1. GDMA Special Registers Overview

Registers	Address	R/W	Description	Reset Value
DPRIC	0xF0051000	R/W	GDMA priority configuration register	0x00000000
DPRIF	0xF0052000	R/W	GDMA programmable priority register for fixed	0x00543210
DPRIR	0xF0053000	R/W	GDMA programmable priority register for round-robin	0x00000000
DCON0	0xF0050000	R/W	GDMA channel 0 control register	0x00000000
DSAR0	0xF0050004	R/W	GDMA channel 0 source address register	0x00000000
DDAR0	0xF0050008	R/W	GDMA channel 0 destination address register	0x00000000
DTCR0	0xF005000C	R/W	GDMA channel 0 transfer count register	0x00000000
DRER0	0xF0050010	W	GDMA channel 0 run enable register	0x00000000
DIPR0	0xF0050014	R/WC	GDMA channel 0 interrupt pending register	0x00000000
DCON1	0xF0050020	R/W	GDMA channel 1 control register	0x00000000
DSAR1	0xF0050024	R/W	GDMA channel 1 source address register	0x00000000
DDAR1	0xF0050028	R/W	GDMA channel 1 destination address register	0x00000000
DTCR1	0xF005002C	R/W	GDMA channel 1 transfer count register	0x00000000
DRER1	0xF0050030	W	GDMA channel 1 run enable register	0x00000000
DIPR1	0xF0050034	R/WC	GDMA channel 1 interrupt pending register	0x00000000
DCON2	0xF0050040	R/W	GDMA channel 2 control register	0x00000000
DSAR2	0xF0050044	R/W	GDMA channel 2 source address register	0x00000000
DDAR2	0xF0050048	R/W	GDMA channel 2 destination address register	0x00000000
DTCR2	0xF005004C	R/W	GDMA channel 2 transfer count register	0x00000000
DRER2	0xF0050050	W	GDMA channel 2 run enable register	0x00000000
DIPR2	0xF0050054	R/WC	GDMA channel 2 interrupt pending register	0x00000000
DCON3	0xF0050060	R/W	GDMA channel 3 control register	0x00000000
DSAR3	0xF0050064	R/W	GDMA channel 3 source address register	0x00000000
DDAR3	0xF0050068	R/W	GDMA channel 3 destination address register	0x00000000
DTCR3	0xF005006C	R/W	GDMA channel 3 transfer count register	0x00000000
DRER3	0xF0050070	W	GDMA channel 3 run enable register	0x00000000
DIPR3	0xF0050074	R/WC	GDMA channel 3 interrupt pending register	0x00000000
DCON4	0xF0050080	R/W	GDMA channel 4 control register	0x00000000
DSAR4	0xF0050084	R/W	GDMA channel 4 source address register	0x00000000
DDAR4	0xF0050088	R/W	GDMA channel 4 destination address register	0x00000000
DTCR4	0xF005008C	R/W	GDMA channel 4 transfer count register	0x00000000
DRER4	0xF0050090	W	GDMA channel 4 run enable register	0x00000000
DIPR4	0xF0050094	R/WC	GDMA channel 4 interrupt pending register	0x00000000
DCON5	0xF00500A0	R/W	GDMA channel 5 control register	0x00000000
DSAR5	0xF00500A4	R/W	GDMA channel 5 source address register	0x00000000
DDAR5	0xF00500A8	R/W	GDMA channel 5 destination address register	0x00000000
DTCR5	0xF00500AC	R/W	GDMA channel 5 transfer count register	0x00000000
DRER5	0xF00500B0	W	GDMA channel 5 run enable register	0x00000000
DIPR5	0xF00500B4	R/WC	GDMA channel 5 interrupt pending register	0x00000000

9.3.1 GDMA PROGRAMMABLE PRIORITY REGISTERS

The GDMA can support the fixed priority and the round-robin priority for the local arbitration of six GDMA channels by register setting. Especially, the GDMA can program the priority order in the fixed priority mode as well as the ratio of the bus occupancy in the round-robin priority mode.

The local priority of six channels of GDMA can be programmed by the fixed priority or the round-robin priority in similar manner to the AHB bus priority. Please refer to Chapter 4, The System Configuration.

The GDMA programmable priority registers are DPRIC (Programmable Priority Register for Configuration), DPRIF (Programmable Priority Register for Fixed) and DPRIR (Programmable Priority Register for Round-Robin).

If the GDMA priority configuration register (0xF0051000) DPRIC = 0x1, the programmable fixed priority is run by DPRIF register. Each GDMA channel has its own fixed priority index. For example, the GDMA channel 0 has the index 0. The reset value of DPRIF register is 0x00543210. The first field of DPRIF[3:0] indicates the highest priority. So, the GDMA channel 0 has the highest priority in local arbitration when DPRIC = 0x1 and the DPRIF has the reset value. For example, DPRIC = 0x1 and the DPRIF is 0x00431520, the fixed priority order from the highest to the lowest is GDMA channel 0, channel 2, channel 5, channel 1, channel 3, and channel 4.

If the GDMA priority configuration register (0xF0051000) DPRIC = 0x0, the programmable round-robin priority is run by DPRIR register. All GDMA channels own their respective field position in DPRIR. The ratio of the bus occupancy can be programmed by writing an arbitrary value on each field. The arbitrary value can be from 0x0 to 0xF. The ratio of the bus occupancy of the GDMA channel in the first field is $(dprir0+1)/((dprir5+1)+(dprir4+1)+(dprir3+1)+(dprir2+1)+(dprir1+1)+(dprir0+1))$. The reset value of DPRIR register is 0x0. So each GDMA channel has the same bus occupancy ratio when DPRIC = 0x0 and the DPRIR has the reset value. For example, DPRIC = 0x0 and the DPRIR is 0x20F100, the expected ratios of the bus occupancy of the GDMA channel 0, channel 1, channel 2, channel 3, channel 4, and channel 5 are 1/24, 1/24, 2/24, 16/24, 1/24, and 3/24, respectively.

Table 9-2. GDMA Programmable Priority Registers

Register	Address	R/W	Description	Reset Value
DPRIC	0xF0051000	R/W	GDMA priority configuration register	0x00000000
DPRIF	0xF0052000	R/W	GDMA programmable priority register for fixed	0x00543210
DPRIR	0xF0053000	R/W	GDMA programmable priority register for round-robin	0x00000000

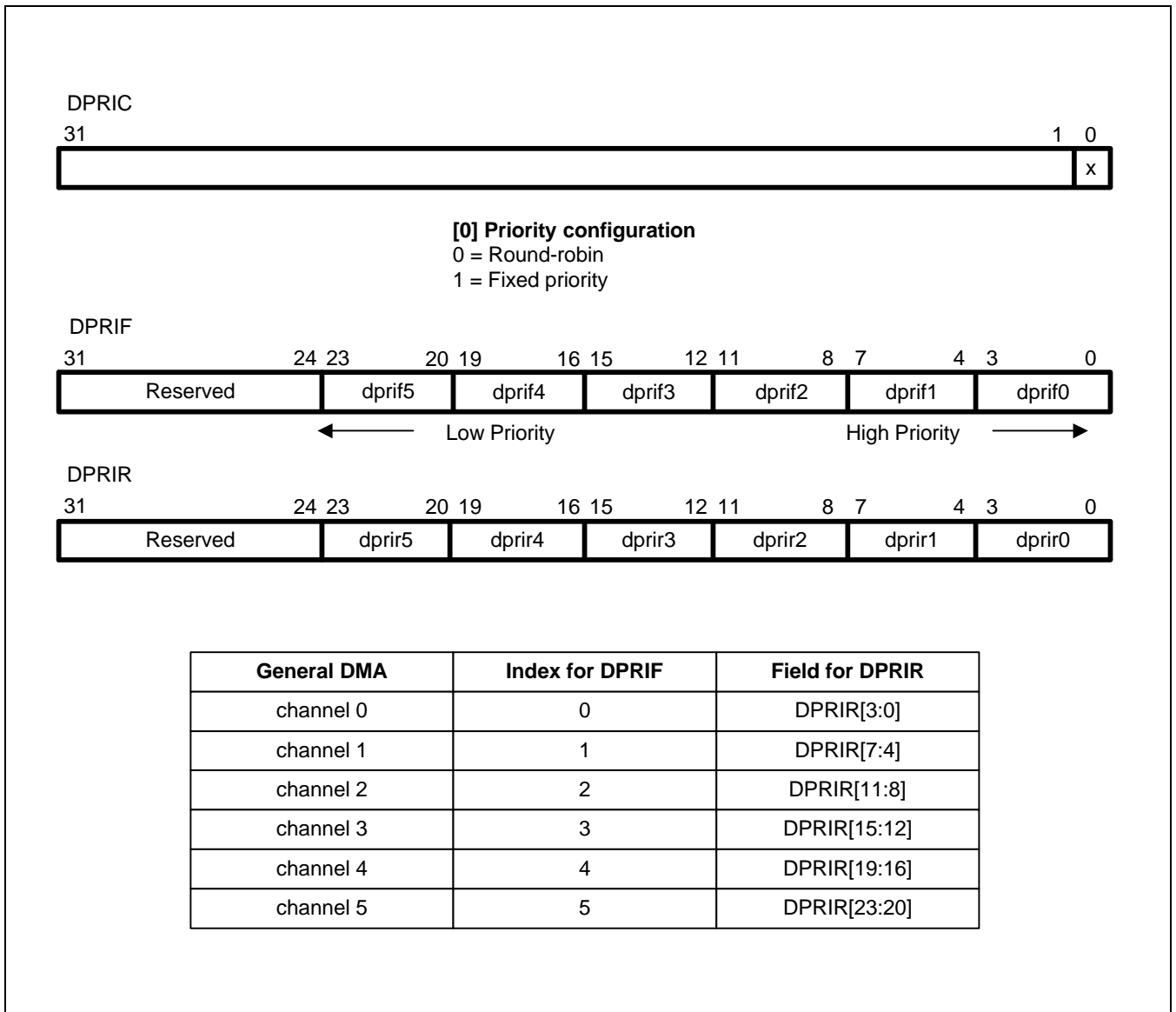

Figure 9-2. GDMA Programmable Priority Registers

9.3.1.1 Problem Solving with Programmable Round-Robin

S3C2501X has stuff to thing about with GDMA arbiter. This only applies to GDMA arbiter with Round-Robin priority. Assuming all '0's are set for GDMA programmable priority register for Round-Robin, HPRIR (all same bus occupancy in Round-Robin), and only three of six channels of GDMA are used, the problem arises as follows.

Number	DPRIR	Channel	Expected Bus Occupancy	Actual GDMA Channel Run	Real System Bus Occupancy
1	0	GDMA 0	1/3	GDMA 0	1/6
2	0	GDMA 1	1/3	GDMA 1	1/6
3	0	GDMA 2	1/3	GDMA 2	1/6
4	0	Not used	0	GDMA 0	1/6
5	0	Not used	0	GDMA 0	1/6
6	0	Not used	0	GDMA 0	1/6

When DPRIR is 0x0 and only GDMA channel 0, 1, and 2 are used, the expected bus occupancy for each channel is 1/3. However, S3C2501X does not work in that way, instead, GDMA channel 0 gets 4/6 of the bus occupancy, GDMA 1 1/6, and GDMA 2 1/6. In short, GDMA 0 is run four times more than GDMA 1, and 2. This is because S3C2501X is designed to turn the bus occupancy to the next channel when there is non-used GDMA channel. For instance,

Number 1: GDMA 0

Number 2: GDMA 1

Number 3: GDMA 2

Number 4: No GDMA → go to number 5: No GDMA → go to number 6: No GDMA → go to number 1: GDMA 0

Number 5: No GDMA → go to number 6: No GDMA → go to number 1: GDMA 0

Number 6: No GDMA → go to number 1: GDMA 0

The following is the problem solving with software.

1. Method 1

DPRIR	Channel	Expected Bus Occupancy	Real System Bus Occupancy
0	GDMA 0	1/3	4/6
0	GDMA 1	1/3	1/6
0	GDMA 2	1/3	1/6
0		0	0
0		0	0
0		0	0

Problem

⇒

DPRIR	Channel	Occupancy
0	GDMA 0	1/3
3	GDMA 1	1/3
3	GDMA 2	1/3
0		0
0		0
0		0

Problem Solving by Method 1

Writing "0x000330", instead of "0x0" will give each channel of three GDMA with the same amount of bus occupancy.

2. Method 2

DPRIR	Channel	Expected Bus Occupancy	Real System Bus Occupancy
0	GDMA 0	1/3	4/6
0	GDMA 1	1/3	1/6
0	GDMA 2	1/3	1/6
0		0	0
0		0	0
0		0	0

Problem

⇒

DPRIR	Channel	Occupancy
0	GDMA 0	1/3
0		0
0	GDMA 2	1/3
0		0
0	GDMA 4	1/3
0		0

Problem Solving by Method 2

With leaving DPRIR as "0x0" and using every other channel, each channel of three GDMA gets the same bus occupancy, as seen above.

GDMA Channel Needed	Recommended Problem Solving	Recommended GDMA Channel Used when S/W 2
1	Method 2	0, 1, 2, 3, 4, or 5
2	Method 2	0/3 or 1/4 or 2/5
3	Method 2	0/2/4 or 1/3/5
4	Method 1	N/A
5	Method 1	N/A
6	Method 2	1, 2, 3, 4, 5, and 6

This method works when 1, 2, 4, or 6 GDMA channels are needed, but there is no solution when 4 or 5 GDMA channels are needed. So we recommend that when you need 1, 2, 3, or 6 GDMA channels, use Method 2, and when you need 4 or 5 GDMA channels, use Method 1.

9.3.2 GDMA CONTROL REGISTERS

Table 9-3. DCON0/1/2/3/4/5 Registers

Registers	Address	R/W	Description	Reset Value
DCON0	0xF0050000	R/W	GDMA channel 0 control register	0x00000000
DCON1	0xF0050020	R/W	GDMA channel 1 control register	0x00000000
DCON2	0xF0050040	R/W	GDMA channel 2 control register	0x00000000
DCON3	0xF0050060	R/W	GDMA channel 3 control register	0x00000000
DCON4	0xF0050080	R/W	GDMA channel 4 control register	0x00000000
DCON5	0xF00500A0	R/W	GDMA channel 5 control register	0x00000000

Table 9-4. GDMA Control Register Description

Bit Number	Bit Name	Description
[0]	Run enable/disable	Setting this bit to "1", starts a GDMA operation. To stop GDMA, you must clear this bit to "0". You can use the DRER (GDMA run enable register) to manipulate this bit. By using the DRER, other GDMA control register values are not affected.
[3:1]	GDMA mode selection	6 GDMA modes can initiate a GDMA operation: 1) software mode (memory to memory, "000"), 2) an external GDMA request mode (xGDMA_Req, "001"), 3) HUART TX mode (HUART from memory, "010"), 4) HUART RX mode (HUART to memory, "011"), 5) DES IN mode (DES from memory, "100"), 6) DES OUT mode (DES to memory, "101").
[4]	Single/Block mode	This bit determines the number of external GDMA requests (xGDMA_Req 0-3) that are required for a GDMA operation. In Single mode, when [4] = "0", the S3C2501X requires an external GDMA request for every GDMA operation. In Block mode, when [4] = "1", the S3C2501X requires only one external GDMA request during the entire GDMA operation. An entire GDMA operation is defined as the operation of GDMA until the counter value is zero. The block mode can be used only when GDMA mode is external GDMA request mode.
[5]	Four-data burst mode	If this bit is set to "1", GDMA operates under four-data burst mode. Four consecutive source addresses are read and then are written to the consecutive destination addresses. If four-data burst mode is set to "1", "Transfer Count Register (DTCR)" should be set carefully because the four-data burst mode is executed during decreasing of the transfer count. But the misalign of "Transfer Counter Register (DTCR)" can be supported. The four-data burst mode can be used only when GDMA mode is software, external GDMA request, or DES mode. You can use four-data burst mode together with block mode of the external GDMA requests.

Table 9-4. GDMA Control Register Description (Continued)

Bit Number	Bit Name	Description
[7:6]	Transfer size	These bits determine the transfer data width to be one byte, one half-word, or one word. If you select a byte transfer operation, the source/destination address will be increased or decreased by one with each transfer. Each half-word transfer increments or decrements the address by two, and each word transfer by four. NOTE: In HUART mode, you should set byte ("00") on transfer size (TS) [7:6] of DCON register. In DES mode, you should set word ("10") on transfer size (TS) [7:6] of DCON register.
[9:8]	Source address direction	These bits control whether the source address will be increased ("00"), decreased ("01"), or fixed ("10") during a GDMA operation. The "fixed" ("10") means the source address will not be changed during a GDMA operation. You use this "fixed" feature when transferring data from a single source to multiple destinations. When DCON MODE [3:1] is HUART RX mode (HUART to memory, "011") or DES OUT mode (DES to memory, "101"), these bits don't care.
[11:10]	Destination address direction	These bits control whether the destination address will be increased ("00"), decreased ("01"), or fixed ("10") during a GDMA operation. The "fixed" ("10") means the destination address will not be changed during a GDMA operation. You use this "fixed" feature when transferring data from multiple sources to a single destination. When DCON MODE [3:1] is HUART TX mode (HUART from memory, "010") or DES IN mode (DES from memory, "100"), these bits don't care.
[12]	Interrupt enable	If the interrupt enable bit is "1", a GDMA interrupt is generated when GDMA operation completes successfully. If this bit is "0", the GDMA interrupt is not generated. If you stop the GDMA operation by resetting the run enable bit, the GDMA interrupt is not generated regardless of this bit.
[16:13]	External GDMA ACK count	These bits control how many cycles of the external GDMA acknowledgment signals provided. If the slow external devices want GDMA service, the slow external devices can sample the external GDMA ACK signal by setting these bits. These bits provide the range of 1 and 16 cycles. If these bits are "0000", the single cycle of the external GDMA ACK are generated. If these bits are "1111", the 16 cycles of the external GDMA ACK are generated.
[31]	Busy status	When GDMA starts, this read-only status bit is automatically set to "1". When it is "0", GDMA is idle. This bit is a read-only bit.

NOTES:

- To ensure the reliability of GDMA operations, the GDMA control register bits must be configured independently and carefully.
- GDMA mode selection should not be set to "010" or "011" for GDMA 0, 1 and 2 because GDMA channel 0, 1 and 2 don't have HUART service. This setting is valid for GDMA channel 3, 4 and 5.
- If you want four-burst-mode (DCON[5]), you should set both SD (DCON[9:8]) and DD (DCON[11:10]) to "00" (increase). But SD (DCON[9:8]) and DD (DCON[11:10]) can be "10" (fixed) only for USB endpoints (software mode) and DES IN/OUT FIFO (DES mode) when four-burst-mode (DCON[5]) is set.

9.3.3 GDMA SOURCE/DESTINATION ADDRESS REGISTERS

The GDMA source/destination address registers contain the 32-bit source/destination addresses for GDMA channels 0, 1, 2, 3, 4, and 5. These address registers cover the whole external memory space, including the special purpose registers. You have to reference the memory map of the S3C2501X (Chapter 4) when you want to set these address registers. Depending on the settings you make to the GDMA control register (DCON), the source or destination addresses will either remain the same, or they will be increased or decreased. When DCON MODE [3:1] is HUART RX mode (HUART to memory, "011") or DES OUT mode (DES to memory, "101"), the DSAR register doesn't care. Also, when DCON MODE [3:1] is HUART TX mode (HUART from memory, "010") or DES IN mode (DES from memory, "100"), the DDAR register doesn't care.

Table 9-5. DSAR0/1/2/3/4/5 and DDAR0/1/2/3/4/5 Registers

Registers	Address	R/W	Description	Reset Value
DSAR0	0xF0050004	R/W	GDMA channel 0 source address register	0x00000000
DSAR1	0xF0050024	R/W	GDMA channel 1 source address register	0x00000000
DSAR2	0xF0050044	R/W	GDMA channel 2 source address register	0x00000000
DSAR3	0xF0050064	R/W	GDMA channel 3 source address register	0x00000000
DSAR4	0xF0050084	R/W	GDMA channel 4 source address register	0x00000000
DSAR5	0xF00500A4	R/W	GDMA channel 5 source address register	0x00000000
DDAR0	0xF0050008	R/W	GDMA channel 0 destination address register	0x00000000
DDAR1	0xF0050028	R/W	GDMA channel 1 destination address register	0x00000000
DDAR2	0xF0050048	R/W	GDMA channel 2 destination address register	0x00000000
DDAR3	0xF0050068	R/W	GDMA channel 3 destination address register	0x00000000
DDAR4	0xF0050088	R/W	GDMA channel 4 destination address register	0x00000000
DDAR5	0xF00500A8	R/W	GDMA channel 5 destination address register	0x00000000

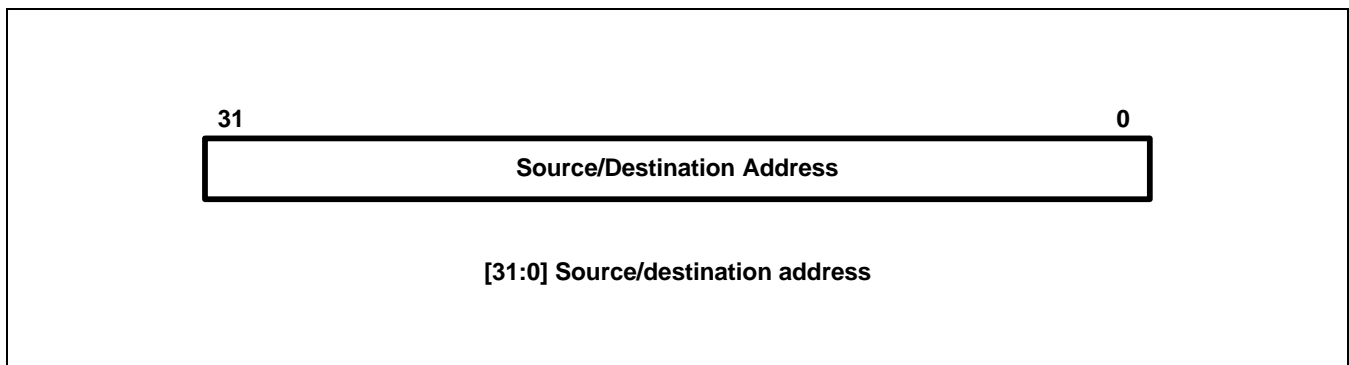

Figure 9-4. GDMA Source/Destination Address Register

9.3.4 GDMA TRANSFER COUNT REGISTERS

The GDMA transfer count register indicates the byte transfer rate, which runs at 24-bit, on GDMA channels 0, 1, 2, 3, 4 and 5.

Whenever GDMA transfer count register transmits the data of GDMA, it will be diminished by transfer width. In other words, when transfer size (TS) is byte, it will be diminished at 1, in the case of half-word at 2 and word at 4. If it is set in four data burst mode, each value of GDMA transfer count will be diminished at 4 times. But if the value of transfer count register is not a multiple of 4 times transfer size, the last misaligned data can be transferred by one transfer size.

Table 9-6. DTCR0/1/2/3/4/5 Registers

Registers	Address	R/W	Description	Reset Value
DTCR0	0xF005000C	R/W	GDMA channel 0 transfer count register	0x00000000
DTCR1	0xF005002C	R/W	GDMA channel 1 transfer count register	0x00000000
DTCR2	0xF005004C	R/W	GDMA channel 2 transfer count register	0x00000000
DTCR3	0xF005006C	R/W	GDMA channel 3 transfer count register	0x00000000
DTCR4	0xF005008C	R/W	GDMA channel 4 transfer count register	0x00000000
DTCR5	0xF00500AC	R/W	GDMA channel 5 transfer count register	0x00000000

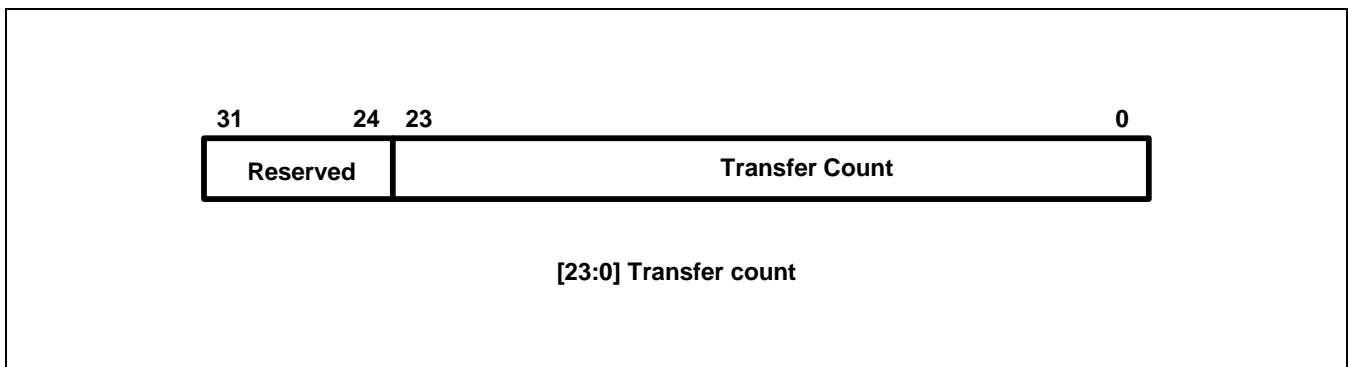

Figure 9-5. GDMA Transfer Count Register

9.3.5 GDMA RUN ENABLE REGISTERS

The GDMA run enable register (DRER) can enable or disable the RUN ENABLE bit, DCON[0] of the GDMA control register (DCON). The DRER register is write-only register.

Table 9-7. DRER0/1/2/3/4/5 Registers

Registers	Address	R/W	Description	Reset Value
DRER0	0xF0050010	W	GDMA channel 0 run enable register	0xFFFFFFFF0
DRER1	0xF0050030	W	GDMA channel 1 run enable register	0xFFFFFFFF0
DRER2	0xF0050050	W	GDMA channel 2 run enable register	0xFFFFFFFF0
DRER3	0xF0050070	W	GDMA channel 3 run enable register	0xFFFFFFFF0
DRER4	0xF0050090	W	GDMA channel 4 run enable register	0xFFFFFFFF0
DRER5	0xF00500B0	W	GDMA channel 5 run enable register	0xFFFFFFFF0

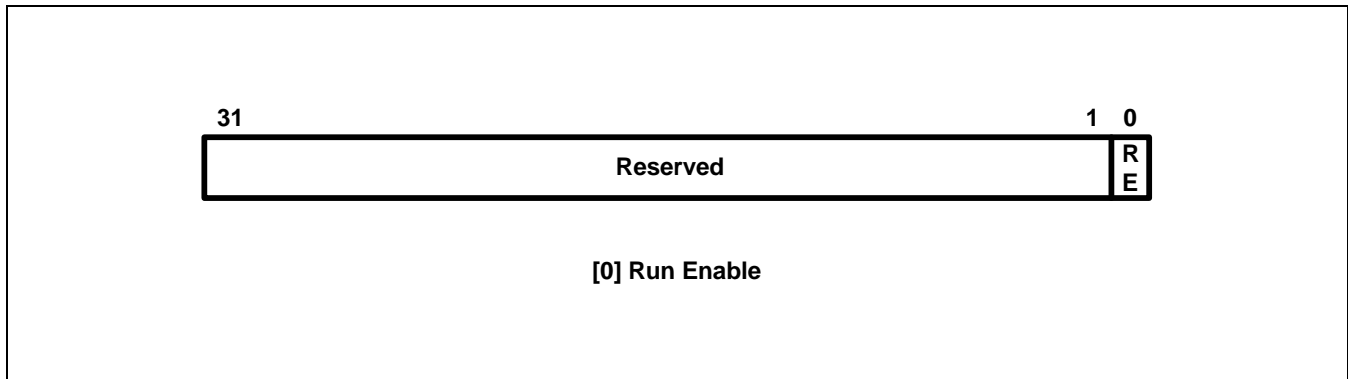

Figure 9-6. GDMA Run Enable Register

9.3.6 GDMA INTERRUPT PENDING REGISTER

The GDMA interrupt pending register (DIPR) indicates the pending state of GDMA interrupt by the pending bit [0] of the DIPR register. The DIPR[0] is active high. The DIPR[0] can be asserted after the GDMA operation completes successfully when the Interrupt Enable field of DCON[12] is "1". Once the GDMA interrupt service routine is called, the DIPR[0] should be de-asserted by writing "1" on DIPR[0] in the beginning of the GDMA interrupt service routine.

Table 9-8. DIPR0/1/2/3 Registers

Registers	Address	R/W	Description	Reset Value
DIPR0	0xF0050014	R/WC	GDMA channel 0 interrupt pending register	0xFFFFFFFF0
DIPR1	0xF0050034	R/WC	GDMA channel 1 interrupt pending register	0xFFFFFFFF0
DIPR2	0xF0050054	R/WC	GDMA channel 2 interrupt pending register	0xFFFFFFFF0
DIPR3	0xF0050074	R/WC	GDMA channel 3 interrupt pending register	0xFFFFFFFF0
DIPR4	0xF0050094	R/WC	GDMA channel 4 interrupt pending register	0xFFFFFFFF0
DIPR5	0xF00500B4	R/WC	GDMA channel 5 interrupt pending register	0xFFFFFFFF0

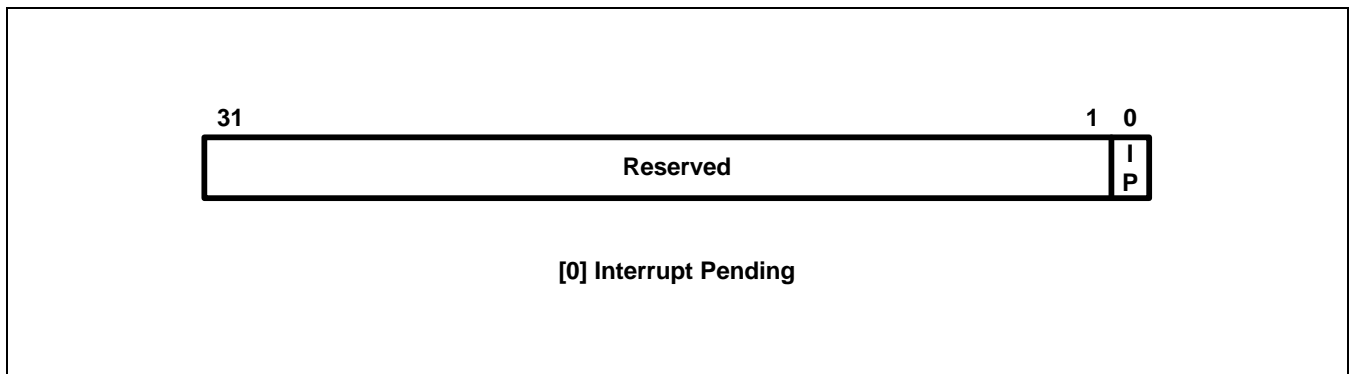

Figure 9-7. GDMA Interrupt Pending Register

9.4 GDMA MODE OPERATION

9.4.1 SOFTWARE MODE

It is the mode that GDMA operates without specific request signal with just setting the enable bit of control register by software. When we want to enable the operation, the data transmission is started by setting [3:1] of GDMA mode selection bit of DCON register to "000" and [0] bit of the same register to "1". This mode can transmit data between the memories by sending the data, which is designated by the source address register to the destination address register. The data transmission size can be byte, half-word, or word. It is determined by setting [7:6] bit of DCON register.

9.4.2 EXTERNAL GDMA REQUEST MODE

GDMA of S3C2501X has four external GDMA request (xGDMA_Req) sources. xGDMA_Req signal and xGDMA_Ack signal can be shared with port signals. So it is used by setting I/O Ports register (IOPCON1). (Refer to Chapter 12, I/O Ports). External device sending xGDMA_Req transmits the data by GDMA during receiving xGDMA_Ack signal. Also external GDMA request mode is used by setting GDMA mode selection bit [3:1] of DCON register to "001". It is similar to the basic operation mode of software, but it is different that GDMA transmits the data only after receiving xGDMA_Req signal. The first external GDMA request xGDMA_Req0 can be serviced by GDMA channel 0 and 4. The second external GDMA request xGDMA_Req1 can be serviced by GDMA channel 1 and 5. The third external GDMA request xGDMA_Req2 can be serviced by GDMA channel 2. The fourth external GDMA request xGDMA_Req3 can be serviced by GDMA channel 3. If the slow external devices need the GDMA service, the slow external devices can sample the external GDMA ACK signal by setting DCON [16:13] bits. DCON [16:13] bits provide the range of 1 and 16 cycles of the external GDMA ACK signal.

NOTE

The block mode can be used only with the external GDMA request mode.

9.4.3 HUART MODE

S3C2501X has one HUART. GDMA channel 3,4,5 can transmit the data of HUART. If GDMA mode selection bit [3:1] to "010" or "011", GDMA gets ready to communicate with HUART. If GDMA mode is "010" (HUART TX mode) and GDMA receives the request signal transmitted from HUART, GDMA transfers Tx data of HUART in memory into Tx buffer/FIFO of HUART. If GDMA mode is "011" (HUART RX mode) and GDMA receives the request signal transmitted from HUART, GDMA transfers Rx data of Rx buffer/FIFO of HUART into memory. When GDMA transmits the data of HUART, GDMA operates in the unit of byte. If it is requested by HUART, only one byte is transmitted and GDMA waits the following request. (At this time if GDMA transfer count register is zero, the operation ends.)

NOTE

In HUART mode, you should set byte ("00") on transfer size (TS) [7:6] of DCON register. In HUART TX mode, you don't need to care the destination address direction (DD) [11:10] of DCON register either the DDAR register. In HUART RX mode, you don't need to care the source address direction (SD) [9:8] of DCON register either the DSAR register.

9.4.4 DES MODE

S3C2501X has only one DES. Any channel of GDMA can transmit the data of DES. If GDMA mode selection bit "100" or "101", GDMA gets ready to communicate with DES. If GDMA mode is "100" (DES IN mode) and GDMA receives the request signal transmitted from DES, GDMA transfers IN data of DES in memory into IN buffer/FIFO of DES. If GDMA mode is "101" (DES OUT mode) and GDMA receives the request signal transmitted from DES, GDMA transfers OUT data of OUT buffer/FIFO of DES into memory.

NOTE

When GDMA is DES mode, GDMA transmits two words by single request. When GDMA is DES mode and four-burst mode is enabled, GDMA transmits four words by single request. But DTCCR register only has to be a multiple of 8 (2 words), because GDMA can transmit the last misaligned data. (At this time if GDMA count register is zero, the operation is ended.) In DES mode, you should set word ("10") on transfer size (TS) [7:6] of DCON register. In DES IN mode, you don't need to care the destination address direction (DD) [11:10] of DCON register either the DDAR register. In DES OUT mode, you don't need to care the source address direction (SD) [9:8] of DCON register either the DSAR register.

9.5 GDMA FUNCTION DESCRIPTION

The following sections provide a functional description of the GDMA controller operations.

9.5.1 GDMA TRANSFERS

The GDMA transfers data directly between a requester and a target. The requester and target can be memory, HUART, DES, special function registers, or external devices. An external device requests the GDMA service by activating xGDMA_Req signal. A channel is programmed by writing to registers, which contain the requester address, the target address, the amount of data, and other control contents. HUART, DES, external I/O, or software (memory) can request GDMA service. HUART and DES are internally connected to the GDMA.

9.5.2 STARTING/ENDING GDMA TRANSFERS

GDMA starts to transfer data after the GDMA receives service request from xGDMA_Req signal, HUART, DES, or software. When the entire buffer of data has been transferred, the GDMA becomes idle. If you want to perform another buffer transfer, the GDMA must be reprogrammed. Although the same buffer transfer will be performed again, the GDMA must be reprogrammed.

9.5.3 DATA TRANSFER MODES

9.5.3.1 Single Mode

A GDMA request (xGDMA_Req or an internal request) causes one byte, one half-word, or one word to be transmitted if four-data burst mode is disabled, or four times of transfer size if four-data burst mode is enabled. Single mode requires a GDMA request for each data transfer. The xGDMA_Req signal can be de-asserted after checking that xGDMA_Ack has been asserted.

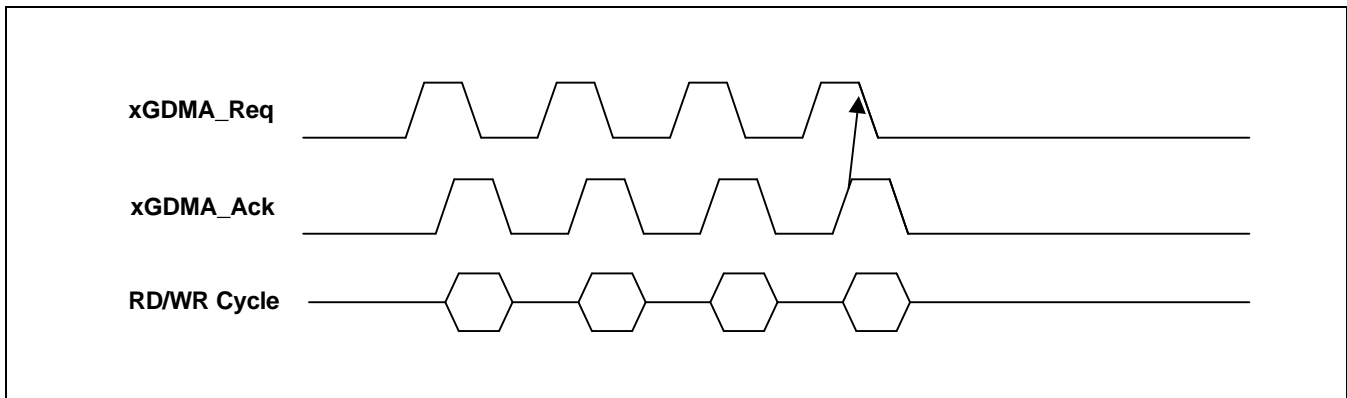

Figure 9-8. External GDMA Requests (Single Mode)

9.5.3.2 Block Mode

The assertion of only one GDMA request (xGDMA_Req or an internal request) causes all of the data, as specified by the control register settings, to be transmitted in a single operation. The GDMA transfer is completed when the transfer counter value reaches zero. The xGDMA_Req signal can be de-asserted after checking that xGDMA_Ack has been asserted.

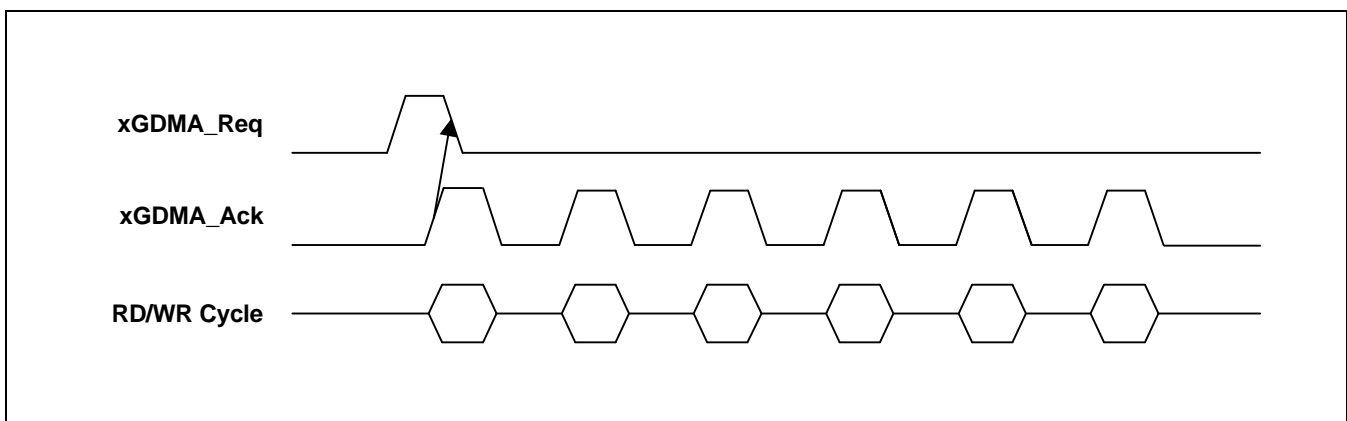

Figure 9-9. External GDMA Requests (Block Mode)

9.6 GDMA TRANSFER TIMING DATA

Figure 9-10 provides the detailed timing data for GDMA data transfers that are triggered by external GDMA requests. Please note that read/write timing depends on which memory banks are selected. The S3C2501X has the internal clock, HCLK, as the operating clock. The clock frequency of HCLK is 133MHz,

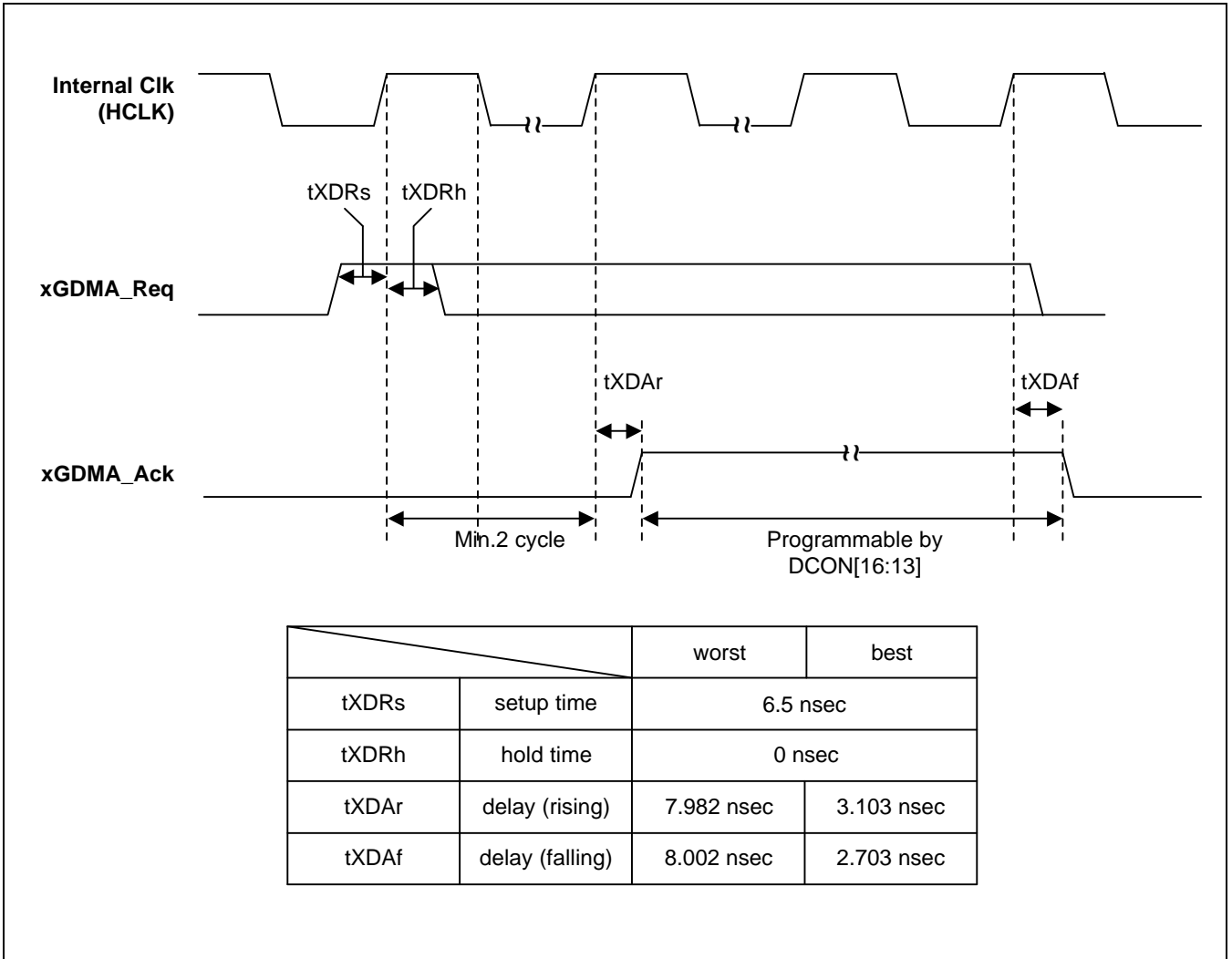

Figure 9-10. External GDMA Requests Detailed Timing

9.6.1 SINGLE AND ONE DATA BURST MODE (DCON[3:1] = 001, [4] = 0, [5] = 0)

xGDMA_Req and xGDMA_Ack signals are active high.

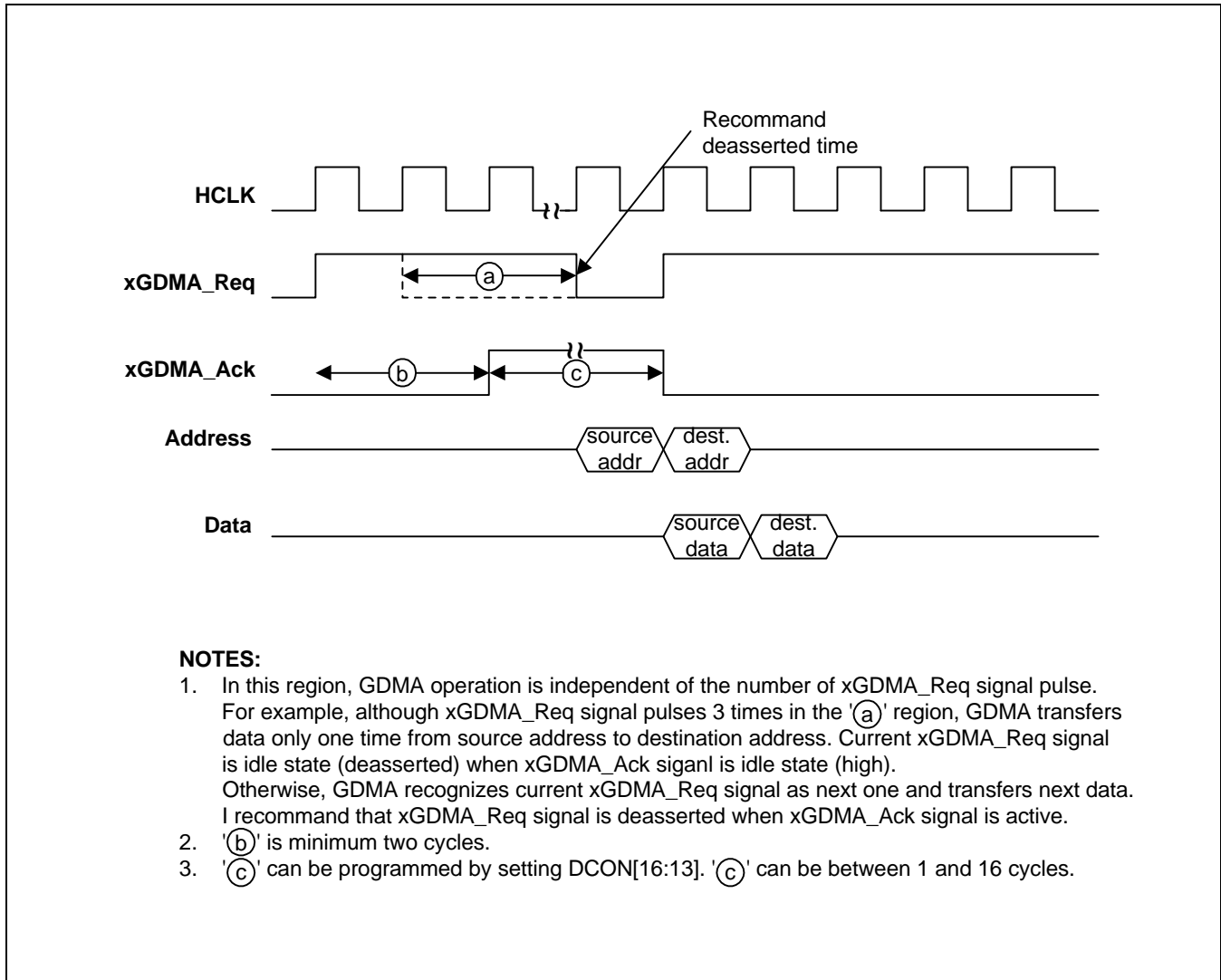

Figure 9-11. Single and One Data Burst Mode Timing

9.6.2 SINGLE AND FOUR DATA BURST MODE (DCON[3:1] = 001, [4] = 0, [5] = 1)

xGDMA_Req and xGDMA_Ack signals are active high.

In four data burst mode, GDMA transfers four data and GDMA Transfer Count Register (DTCR) value decreases by four. But if the value of transfer count register is not a multiple of 4 times transfer size, the last misaligned data can be transferred by one transfer size.

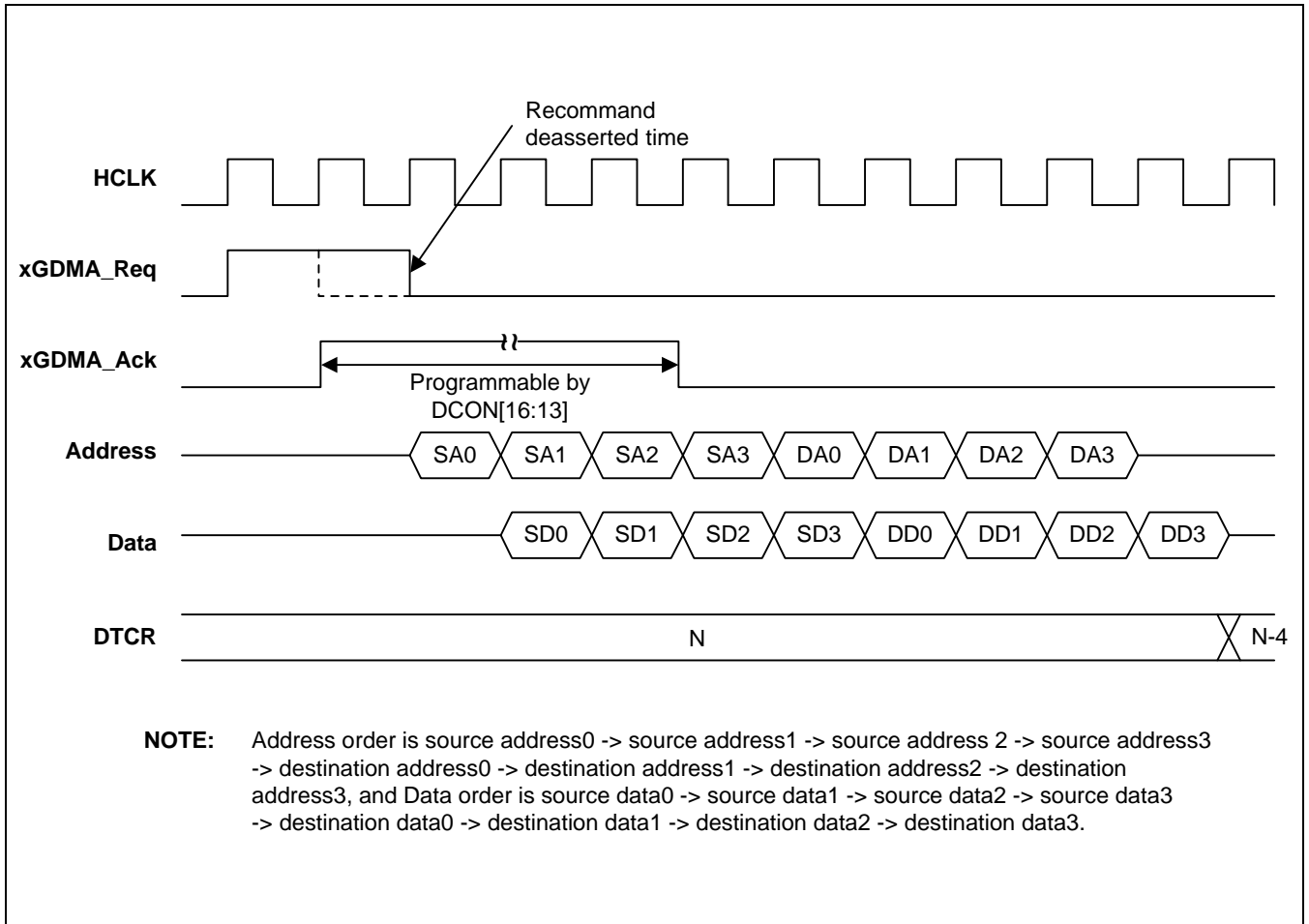

Figure 9-12. Single and Four Data Burst Mode Timing

9.6.3 BLOCK AND ONE DATA BURST MODE (DCON[3:1] = 001, [4] = 1, [5] = 0)

xGDMA_Req and xGDMA_Ack signals are active high.

GDMA transfers data from single xGDMA_Req signal till GDMA Transfer Count Register (DTCR) consumes to 0.

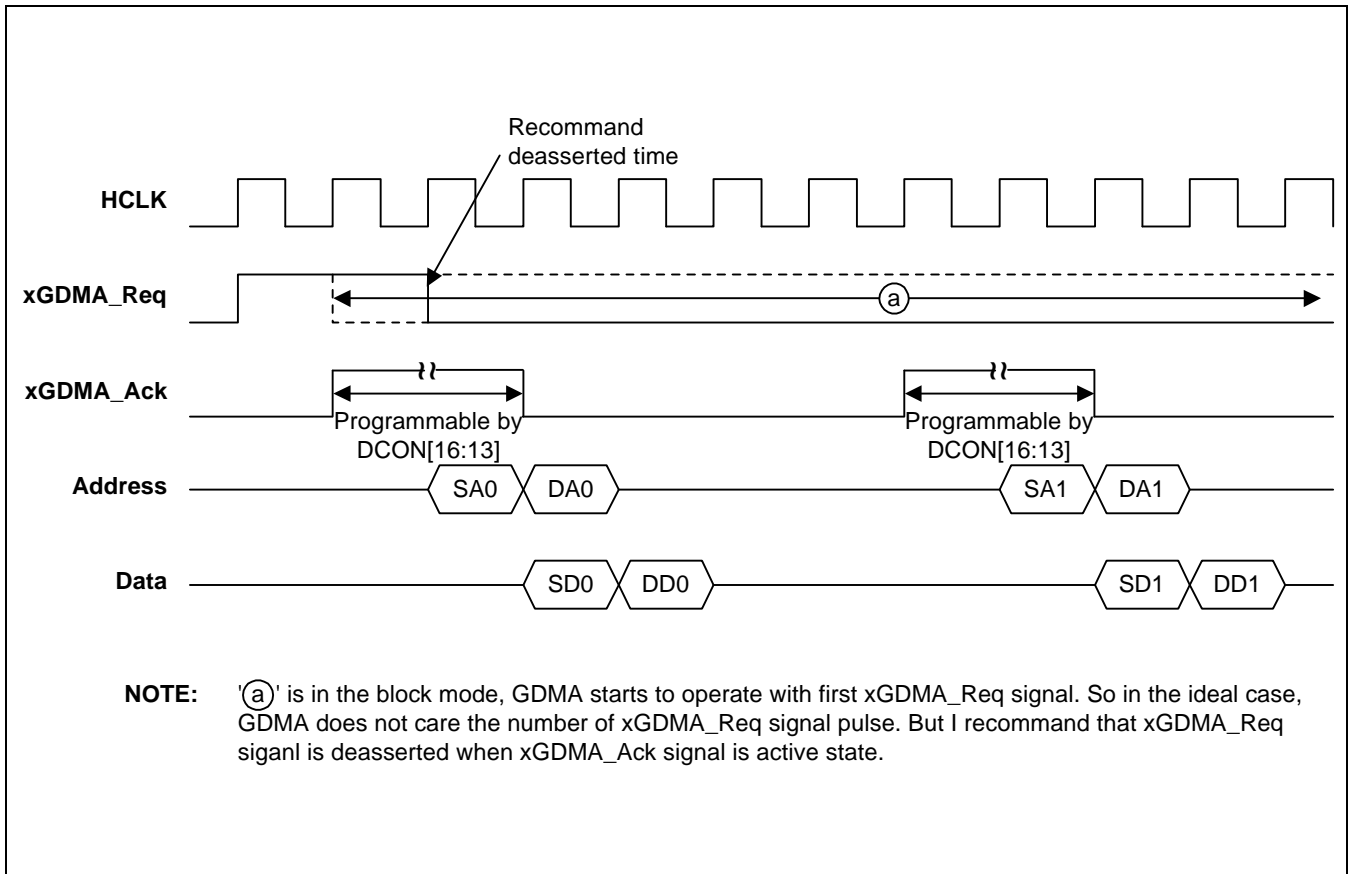

Figure 9-13. Block and One Data Burst Mode Timing

9.6.4 BLOCK AND FOUR DATA BURST (DCON[3:1] = 001, [4] = 1, [5] = 1)

This timing diagram is the same with block and one data burst, except that it is four data burst.

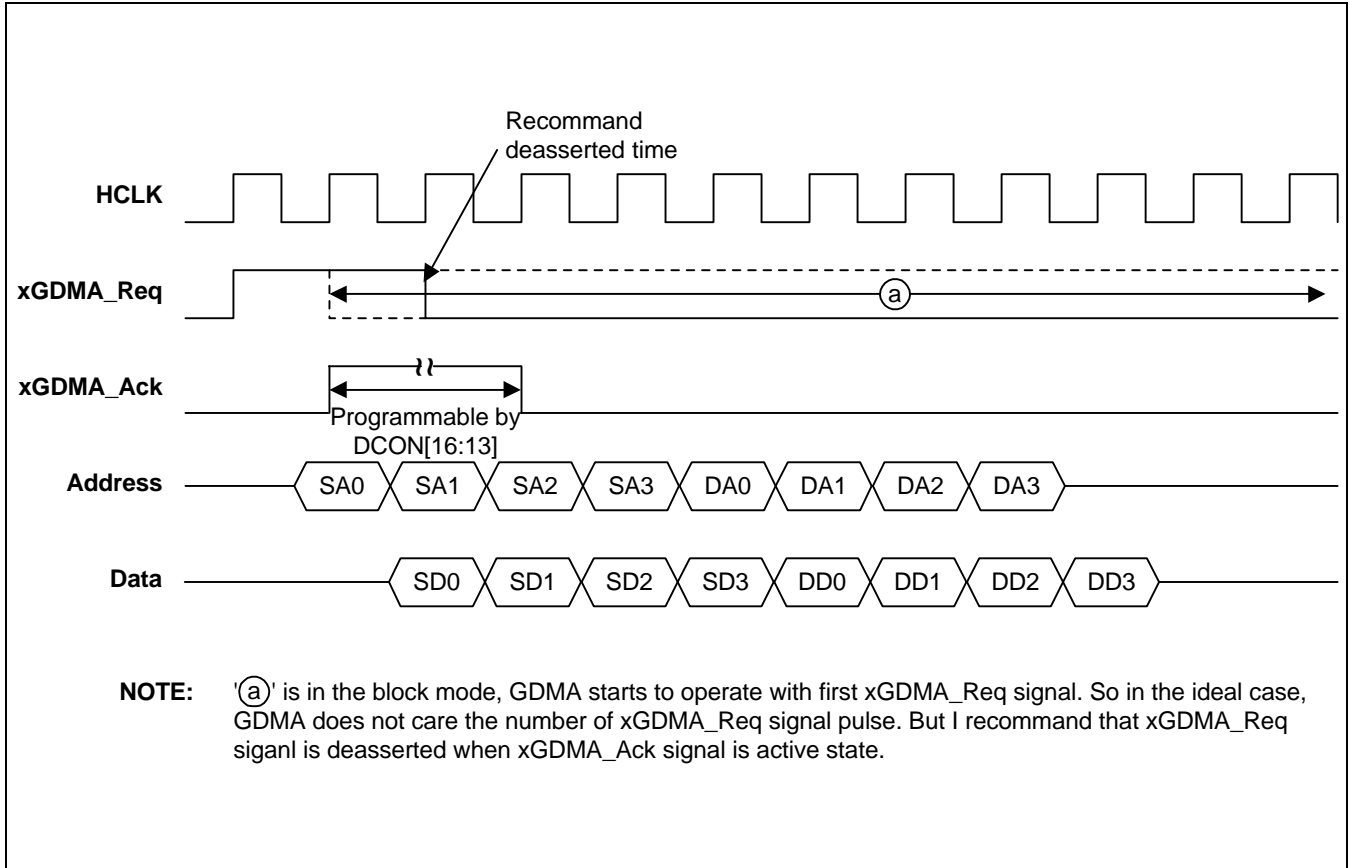

Figure 9-14. Block and Four Data Burst Timing

one data burst; source address0 and source data0 → destination address0 and destination data0 → ...

four data burst; source address0 and source data0 → source address1 and source data1 → source address2 and source data2 → source address3 and source data3 → destination address0 and destination data0 → destination address1 and destination data1 → destination address2 and destination data2 → destination address3 and destination data3 → source address4 and source data4 → ...

NOTE

In four data burst mode, GDMA transfers four data and GDMA Transfer Count Register (DTCR) value decreases by four.

NOTES

10 SERIAL I/O (CONSOLE UART)

10.1 OVERVIEW

The S3C2501X Console UART (Universal Asynchronous Receiver/Transmitter) unit provides one independent asynchronous serial I/O (SIO) port. The port can operate in interrupt-based mode. That is, the Console UART can generate internal interrupts to transfer data between the CPU and the serial I/O port.

10.2 FEATURES

The most important features of the S3C2501X Console UART include:

- Programmable baud rates
- Console UART source clock selectable (Internal clock: PCLK2, External clock: EXT_UCLK)
- ($PCLK2 = PCLK / 2$)
- Infra-red (IR) transmit/receive
- Insertion of one or two Stop bits per frame
- Selectable 5-bit, 6-bit, 7-bit, or 8-bit data transfers
- Parity checking

SIO unit has a baud rate generator, transmitter, receiver, and a control unit, as shown in Figure 10-1. The baud-rate generator can be driven by the internal system clock, PCLK2, or by the external clock, EXT_UCLK. The transmitter and receiver blocks have independent data registers and shifters.

Transmit data is written first to the transmit data register. From there, it is copied to the transmit shifter and then shifted out by the transmit data pin, CUTXD. Receive data is shifted in by the receive data pin, CURXD. It is then copied from the shifter to the receive data register when one data byte has been received.

The SIO control unit provides software controls for mode selection, and for status and interrupt generation. In S3C2501X, software flow control can be selected according to the application.

The SIO control unit supports echo mode. Received data from CURXD send to not only CURXBUF but also CUTXD. This mode is for test only.

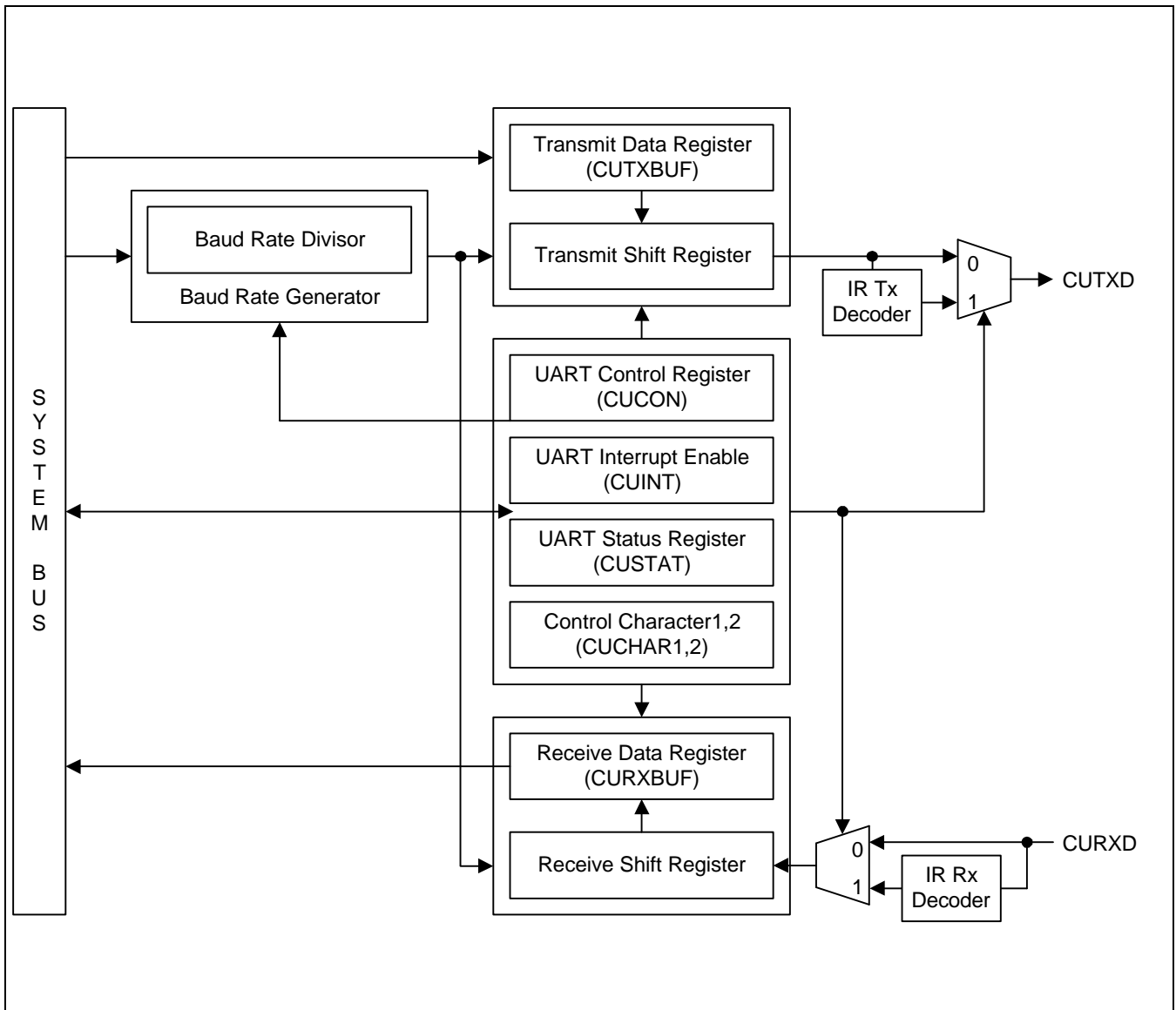

Figure 10-1. Console UART Block Diagram

10.3 CONSOLE UART SPECIAL REGISTERS

Table 10-1. Console UART Special Registers Overview

Register	Address	R/W	Description	Size	Reset Value
CUCON	0xF0060000	R/W	Console UART control register	W	0x00000000
CUSTAT	0xF0060004	R/W	Console UART status register	W	0x00060800
CUINT	0xF0060008	R/W	Console UART interrupt enable register	W	0x00000000
CUTXBUF	0xF006000C	W	Console UART transmit data register	B	–
CURXBUF	0xF0060010	R	Console UART receive data register	B	–
CUBRD	0xF0060014	R/W	Console UART baud rate divisor register	H	0x0000
CUCHAR1	0xF0060018	R/W	Console UART control character register 1	W	0x00000000
CUCHAR2	0xF006001C	R/W	Console UART control character register 2	W	0x00000000

10.3.1 CONSOLE UART CONTROL REGISTERS

Table 10-2. CUCON Registers

Register	Address	R/W	Description	Size	Reset Value
CUCON	0xF0060000	R/W	Console UART control register	W	0x00000000

Table 10-3. Console UART Control Register Description

Bit Number	Bit Name	Description
[1:0]	Transmit mode (TMODE)	This two-bit value determine which function is currently able to write TX data to the Console UART transmit data register, CUTXBUF. 00 = Disable TX mode 01 = CPU request 10 = Reserved 11 = Reserved
[3:2]	Receive mode (RMODE)	This two-bit value determine which function is currently able to read RX data from the Console UART receive data register, CURXBUF. NOTE: Changing these bits (TMODE, RMODE) while transmitting/receiving cause abnormal UART operation. To prevent Tx/Rx data from being lost, changing these bits while transmitting/receiving is strictly prohibited. 00 = Disable RX mode 01 = CPU request 10 = Reserved 11 = Reserved
[4]	Send Break (SBR)	Set this bit to one to cause the Console UART to send a break. If this bit value is zero, a break does not send. A break is defined as a continuous Low level signal on the transmit data output with the duration of more than one frame transmission time.
[5]	Serial Clock Select (SCSEL)	This select bit specifies the clock source 0 = Internal (PCLK2) 1 = External (EXT_UCLK)
[6]	Reserved	Reserved
[7]	Loop-back mode (LOOPB)	Setting this bit causes the Console UART to enter Loop-back mode. In Loop-back mode, the transmit data output, CUTXD, keeps '1' and the transmit data register, CUTXBUF, is internally connected to the receive data register, CURXBUF. NOTE: This mode is provided for test purposes only. For normal operation, this bit should always be '0'.
[10:8]	Parity mode (PMD)	The 3-bit parity mode value specifies how parity generation and checking are performed during Console UART transmit and receive operations: 0xx = No parity 100 = Odd parity 101 = Even parity 110 = Parity is forced/checked as a '1' 111 = Parity forced/checked as a '0'
[11]	Number of Stop bits (STB)	This bit specifies how many stop bits are used to signal end-of-frame (EOF): 0 = One stop bit per frame 1 = Two stop bit per frame

Table 10-3. Console UART Control Register Description (Continued)

Bit Number	Bit Name	Description
[13:12]	Word Length (WL)	This two bit word length value indicates the number of data bits to be transmitted or received per frame: 00 = 5bits 01 = 6bits 10 = 7bits 11 = 8bits
[14]	Infra-red mode (IR)	The S3C2501X Console UART block supports infra-red (IR) transmit and receive operations. In IR mode, the transmit period is pulsed at a rate of 3/16 that of the normal serial transmit rate (when the transmit data value in the CUTXBUF register is zero). To enable IR mode operation, you set CUCON[14] to '1'. Otherwise, the Console UART operates in normal mode. In IR receive mode, the receiver must detect the 3/16 pulsed period to recognize a zero value in the receiver data register, CURXBUF, as the IR receive data. When this bit is '0', normal Console UART mode is selected. When it is '1', infra-red TX/RX mode is selected. NOTE: Changing this bit while transmitting cause one Tx data losing. Because level of infra-red frame start bit and idle state of normal frame are identically high.
[28:15]	Reserved	Reserved
[29]	Software Flow Control Enable (SFEN)	This bit determines whether Console UART select software flow control or not. If you set CUCON[29] to '1', Console UART will act in software flow control. In this mode, you have to use Control Character register.
[30]	Echo Mode Enable (ECHO)	If you set CUCON[30] to '1', RX data is sent not only CURXBUF but also TX port directly, so CUTXBUF data will not be transmitted.
[31]	Reserved	Reserved

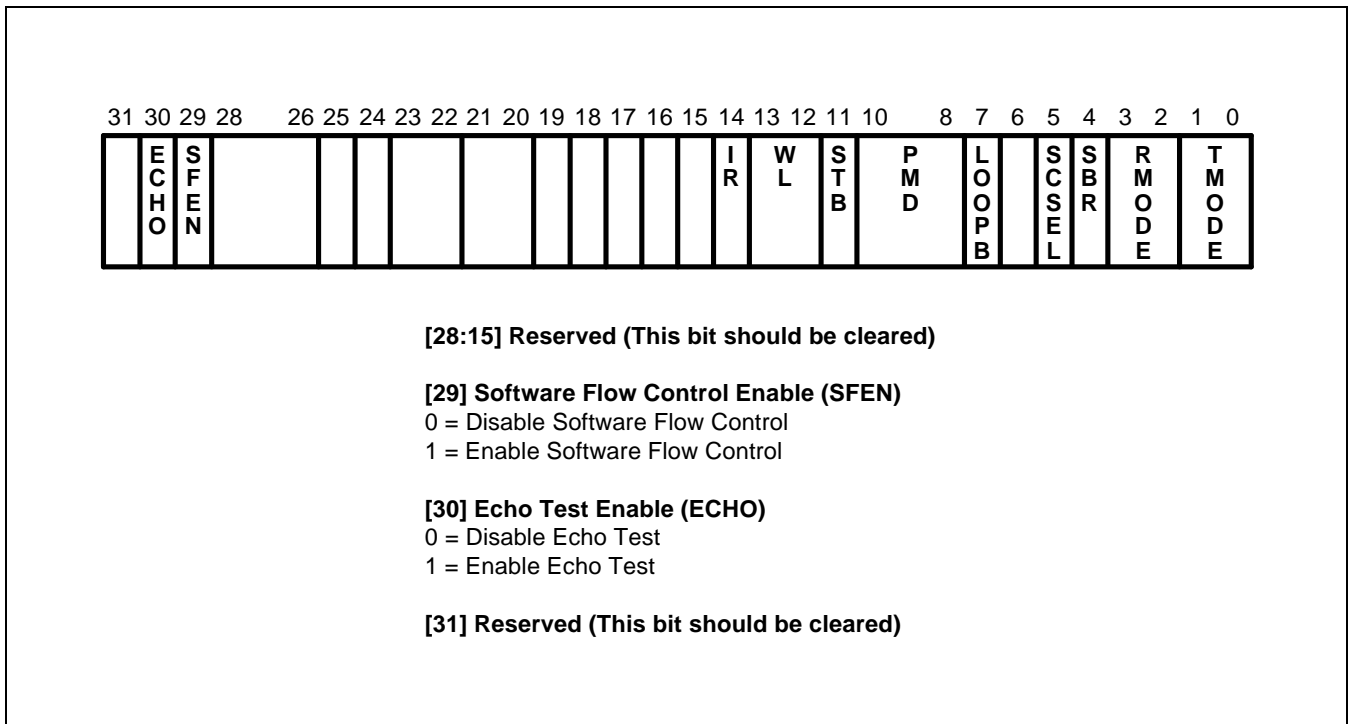

Figure 10-3. Console UART Control Register

10.3.2 CONSOLE UART STATUS REGISTERS

Table 10-4. CUSTAT Registers

Register	Address	R/W	Description	Size	Reset Value
CUSTAT	0xF0060004	R/W	Console UART status register	W	0x00060800

Table 10-5. Console UART Status Register Description

Bit Number	Bit Name	Description
[0]	Receive Data Valid (RDV)	This bit is automatically set to one when CURXBUF contains a valid data received over the serial port. The received data can be read from CURXBUF. When this bit is '0', there is no valid data. If you set CUCON[3:2] to 2'b01 and CUINT[0] to 1'b1, the RDV interrupt is requested. You can clear this bit by reading CURXBUF.
[1]	Break Signal Detected (BKD)	This bit is automatically set to one to indicate that a break signal has been received in CURXBUF. If the BSD interrupt enable bit, CUINT[1], is '1', a interrupt is generated when a break occurs. You can clear this bit by writing '1' to this bit.
[2]	Frame Error (FER)	This bit is automatically set to '1' whenever a frame error occurs during a serial data receive operation. A frame error occurs when a zero is detected instead of the stop bit(s). If the FER interrupt enable bit, CUINT[2], is '1' a interrupt is generated when a frame error occurs. You can clear this bit by writing '1' to this bit.
[3]	Parity Error (PER)	This bit is automatically set to '1' whenever a parity error occurs during a serial data receive operation. If the PER interrupt enable bit, CUINT[3], is '1', a interrupt is generated when a parity error occurs. You can clear this bit by writing '1' to this bit.

Table 10-5. Console UART Status Register Description (Continued)

Bit Number	Bit Name	Description
[4]	Overrun Error (OER)	This bit is automatically set to '1' whenever an overrun error occurs during a serial data receive operation. When CURXBUF has a previous valid data and a new received data is going to be written into CURXBUF, CUSTAT[4] is set to '1'. If the OER interrupt enable bit, CUINT[4], is '1', a interrupt is generated when a overrun error occurs. You can clear this bit by writing '1' to this bit.
[5]	Control Character Detect (CCD)	CUSTAT[5] is automatically set to '1' to indicate that a control character has been received. If the CCD interrupt enable bit, CUINT[5], is '1', an interrupt is generated when a control character is detected. You can clear this bit by writing '1' to this bit. NOTE: Software Flow Control mode does not affects Tx/Rx operation this bit. This bit informs only whether UART receives control character or not. Namely, if user want to stop Tx/Rx operation. User must program that routine.
[10:6]	Reserved	Reserved
[11]	Receiver in idle (RXIDLE)	This bit is only for CPU to monitor the receiver state of console UART. The RXIDLE status bit indicates that the inactive state of CURXBUF.
[16:12]	Reserved	
[17]	Transmitter Idle (TI)	CUSTAT[17] is automatically set to '1' when the transmit holding register has no valid data to transmit and when the TX shift register is empty. The reset value is '1'
[18]	Transmit Holding Register Empty (THE)	When CUTXBUF is empty without regarding TX shift register , this bit set to '1'. An interrupt is generated when CUSTAT[18] is '1', CUCON[1:0] is '01', and CUINT[18] is '1'. You can clear this bit by writing some data into CUTXBUF.
[31:19]	Reserved	Reserved

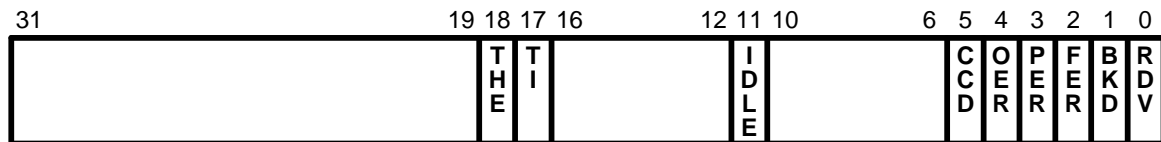
**[0] Receive Data Valid (RDV)**

0 = No valid data (Receive FIFO top or CURXBUF)
 1 = Valid data present (Receive FIFO top or CURXBUF)

[1] Break Signal Deteced (BKD)

0 = No Break Signal (Receive FIFO top or CURXBUF)
 1 = Break received

[2] Frame Error (FER)

0 = No Frame Error (Receive FIFO top or CURXBUF)
 1 = Frame Error occurred

[3] Parity Error (PER)

0 = No Frame Error (Receive FIFO top or CURXBUF)
 1 = Parity Error occurred

[4] Overrun Error (OER)

0 = No Overrun Error (Receive FIFO top or CURXBUF)
 1 = Overrun Error occurred

[5] Control Character Detect (CCD)

0 = No Control Character (Receive FIFO top or CURXBUF)
 1 = Control character present (Receive FIFO top or CURXBUF)

[10:6] Reserved**[11] Receiver in IDLE (IDLE)**

0 = Receiver is in active state
 1 = Receiver is in IDLE state

[16:12] Reserved**[17] Transmitter Idle (TI)**

0 = Transmit is in progress
 1 = Transmitter is in idle: no data for Tx

[18] Transmit Holding Register Empty (THE)

0 = Transmit holding register is not empty
 1 = Transmit holding register is empty

[31:19] Reserved**Figure 10-4. Console UART Status Register**

10.3.3 CONSOLE UART INTERRUPT ENABLE REGISTER

Table 10-6. CUINT Registers

Register	Address	R/W	Description	Size	Reset Value
CUINT	0xF0060008	R/W	Console UART interrupt enable register	W	0x00000000

Table 10-7. Console UART Interrupt Enable Register Description

Bit Number	Bit Name	Description
[0]	RDVIE	Receive Data Valid interrupt enable
[1]	BKDIE	Break Signal Detected interrupt enable
[2]	FERIE	Frame Error interrupt enable
[3]	PERIE	Parity Error interrupt enable
[4]	OERIE	Overrun Error interrupt enable
[5]	CCDIE	Control Character Detect interrupt enable
[16:6]	Reserved	
[17]	TIIE	Transmitter Idle interrupt enable
[18]	THEIE	Transmit Holding Register Empty interrupt enable
[31:19]	Reserved	

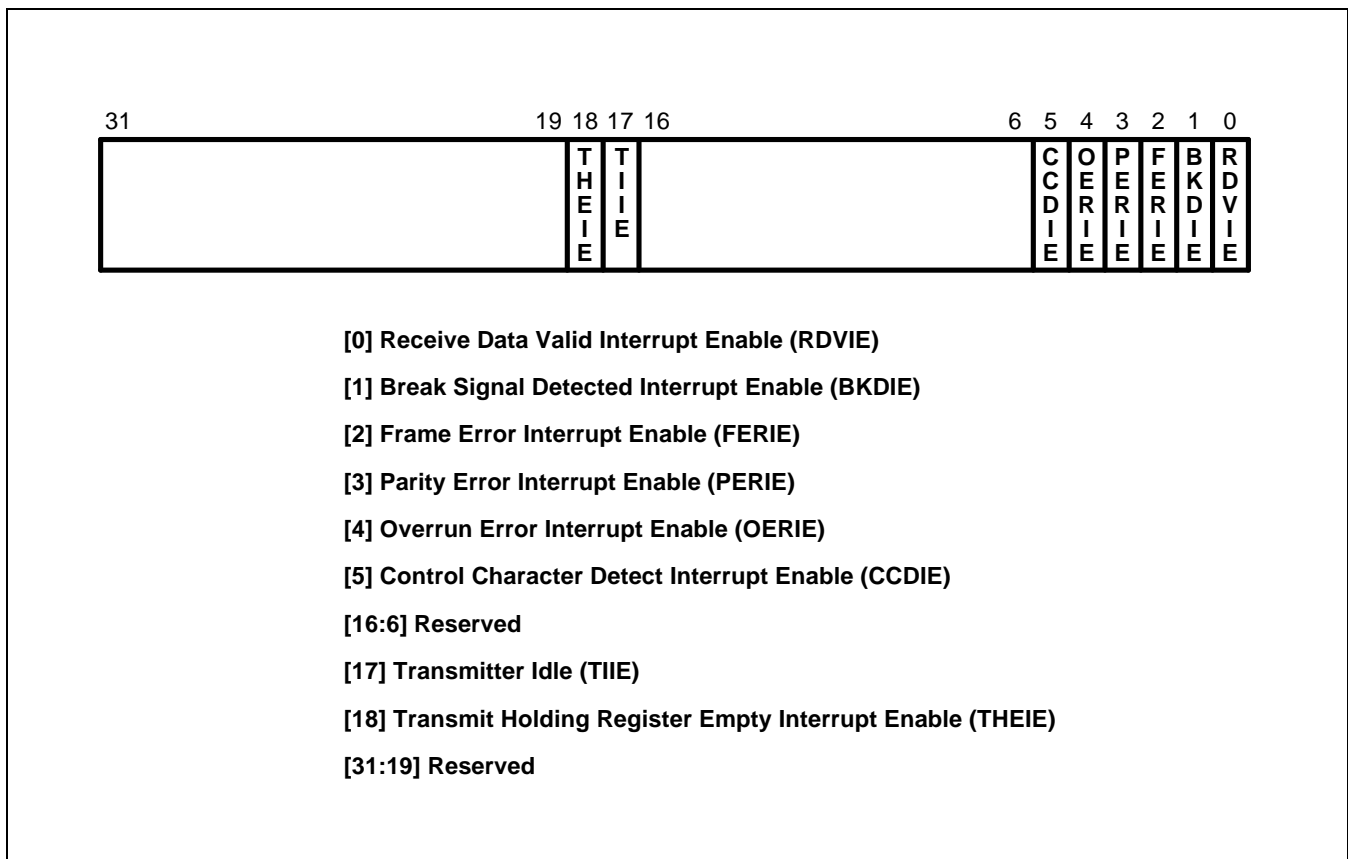

Figure 10-5. Console UART Interrupt Enable Register

10.3.4 UART TRANSMIT DATA REGISTER

Table 10-8. CUTXBUF Registers

Register	Address	R/W	Description	Size	Reset Value
CUTXBUF	0xF006000C	W	Console UART transmit data register	B	–

Table 10-9. Console UART Transmit Register Description

Bit Number	Bit Name	Description
[7:0]	Transmit data	This field contains the data to be transmitted over the single channel Console UART. When this register is written, the transmit data register empty bit in the status register, CUSTAT[18], should be '1'. This is to prevent overwriting of transmit data that may already be present in the CUTXBUF. Whenever the CUTXBUF is written with a new value, the transmit register empty bit, CUSTAT[18], is automatically cleared to '0'.

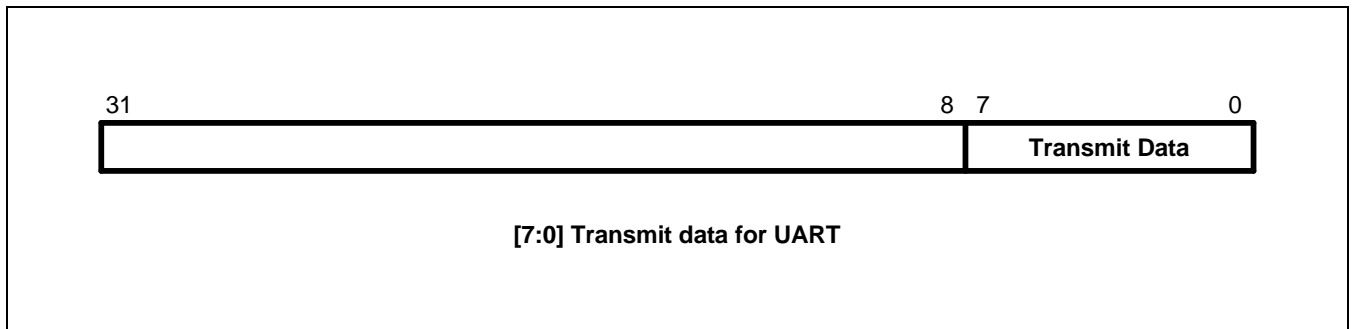

Figure 10-6. Console UART Transmit Data Register

10.3.5 UART RECEIVE DATA REGISTER

Table 10-10. CURXBUF Registers

Register	Address	R/W	Description	Size	Reset Value
CURXBUF	0xF0060010	R	Console UART receive data register	B	–

Table 10-11. Console UART Receive Register Description

Bit Number	Bit Name	Description
[7:0]	Receive data	This field contains the data received over the single channel Console UART. When the Console UART finishes receiving a data frame, the receive data ready bit in the Console UART status register, CUSTAT[0], should be '1'. This prevents reading invalid receive data that may already be present in the CURXBUF. Whenever the CURXBUF is read, the receive data valid bit(CUSTAT[0]) is automatically cleared to '0'.

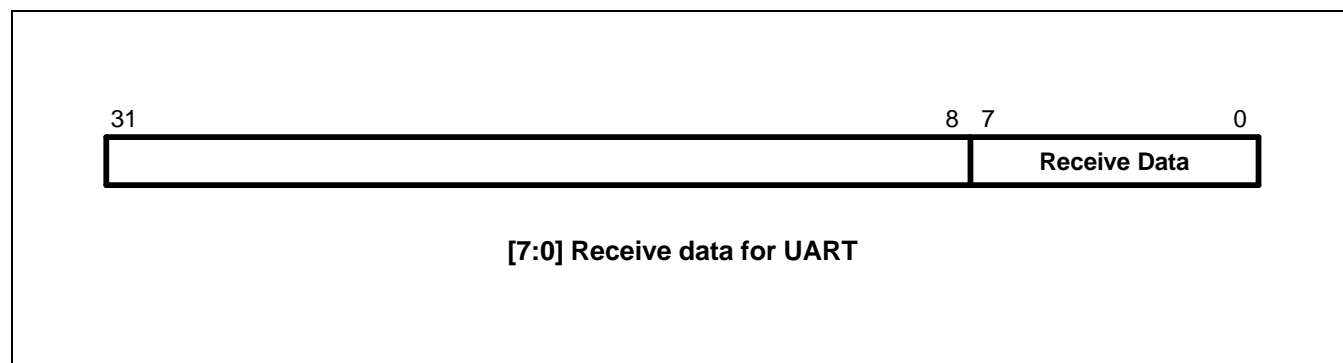

Figure 10-7. Console UART Receive Data Register

10.3.6 UART BAUD RATE DIVISOR REGISTER

The values stored in the baud rate divisor registers, CUBRD, let you determine the serial TX/RX clock rate (baud rate) as follows:

$$BRGOUT = \frac{PCLK2 \text{ or } EXT_UCLK}{(CNT0+1) \times 16^{CNT1} \times 16}$$

Table 10-12. CUBRD Registers

Register	Address	R/W	Description	Size	Reset Value
CUBRD	0xF0060014	R/W	Console UART baud rate divisor register	H	0x0000

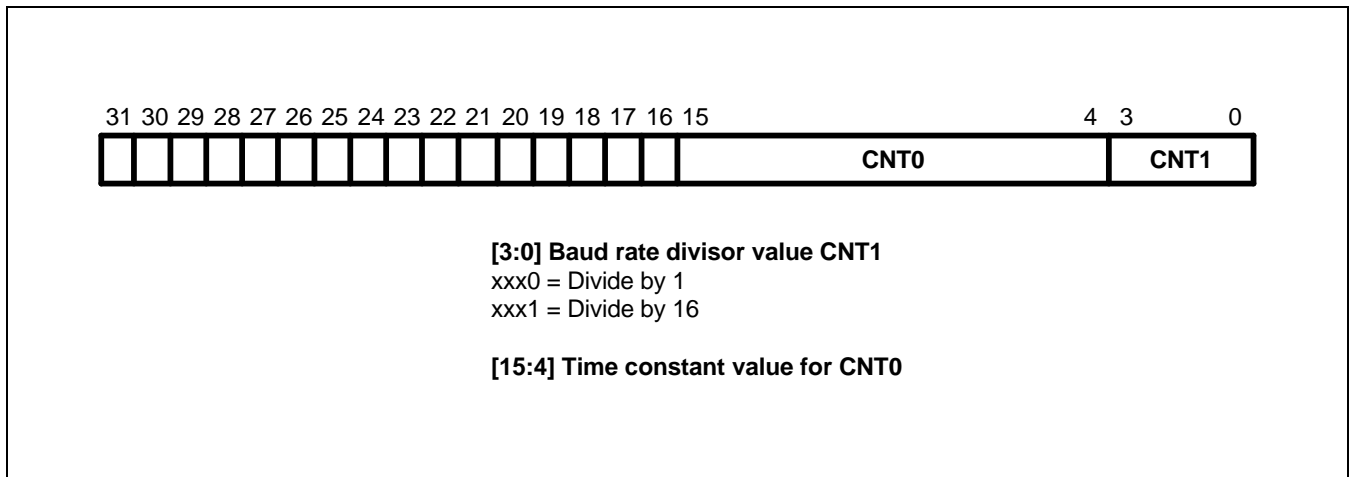

Figure 10-8. Console UART Baud Rate Divisor Register

10.3.7 CONSOLE UART BAUD RATE EXAMPLES

If the system clock frequency is 133 MHz and PCLK2 is selected, the maximum BRGOUT output clock rate is PCLK2/16 (= 4,156,250 Hz).

EXT_UCLK is the external clock input pin for Console UART. PCLK2 and EXT_UCLK can be selected by CUCON[5] register.

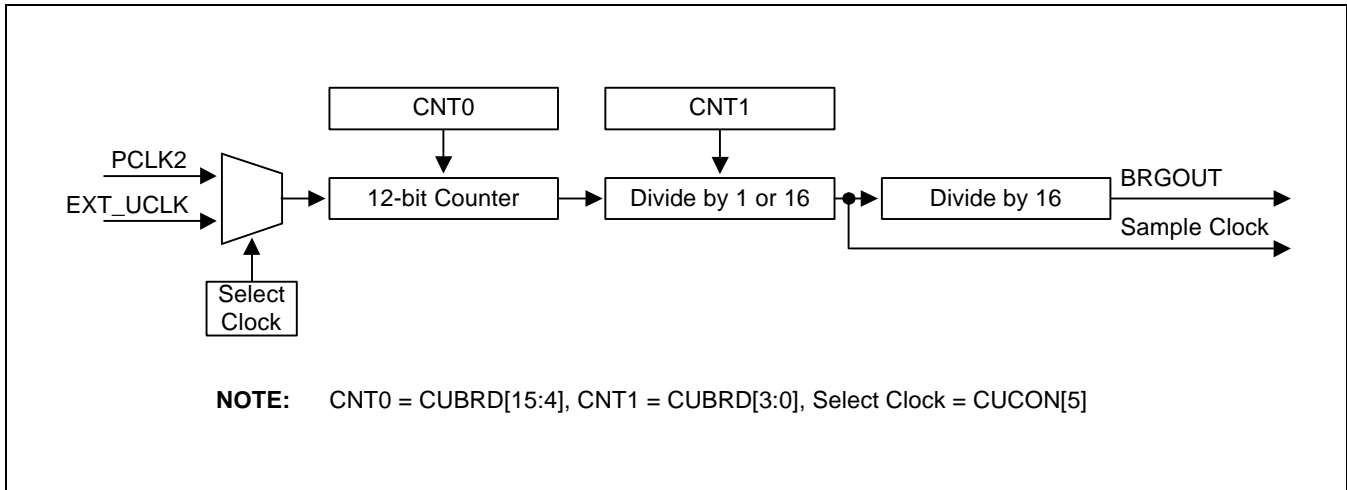

Figure 10-9. Console UART Baud Rate Generator (BRG)

Table 10-13. Typical Baud Rates Examples of Console UART

Baud Rates (BRGOUT)	PCLK2 = 66.5 MHz				EXT_UCLK = 29.4912 MHz			
	CNT0 (DEC/HEX)	CNT1	Freq.	Dev.(%)	CNT0 (DEC/HEX)	CNT1	Freq.	Dev.(%)
1200	3463/D87	0	1199.84	0.01	1535/5FF	0	1200.00	0.00
2400	1731/6C3	0	2399.68	0.01	767/2FF	0	2400.00	0.00
4800	865/361	0	4799.36	0.01	383/17F	0	4800.00	0.00
9600	432/1B0	0	9598.73	0.01	191/BF	0	9600.00	0.00
19200	215/D7	0	19241.90	0.01	95/5F	0	19200.00	0.00
38400	107/6B	0	38483.80	0.22	47/2F	0	38400.00	0.00
57600	71/47	0	57725.69	0.22	31/1F	0	57600.00	0.00
115200	35/23	0	115451.39	0.22	15/F	0	115200.00	0.00

10.3.8 UART CONTROL CHARACTER REGISTER 1 AND 2

These Control Character registers can be used for Software Flow control. In Software Flow Control mode, you should write control characters into these registers. Any character in these registers can be used as a software control flow character and you can use maximum 8 characters for it.

Table 10-14. CUCHAR 1, 2 Registers

Register	Address	R/W	Description	Size	Reset Value
CUCHAR1	0xF0060018	R/W	Console UART control character register 1	W	0x00000000
CUCHAR2	0xF006001C	R/W	Console UART control character register 2	W	0x00000000

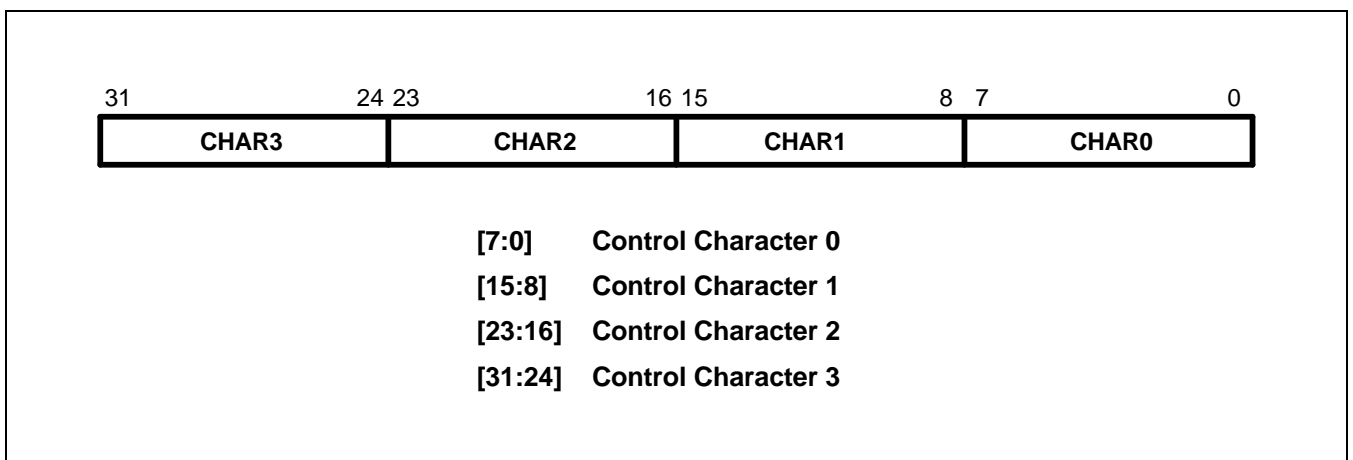

Figure 10-10. Console UART Control Character 1 Register

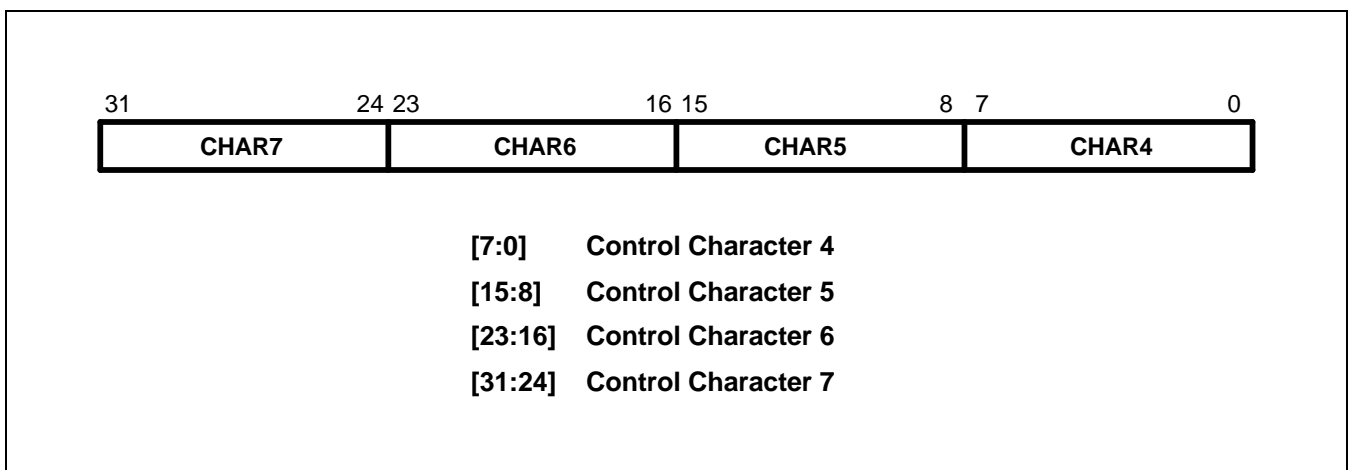

Figure 10-11. Console UART Control Character 2 Register

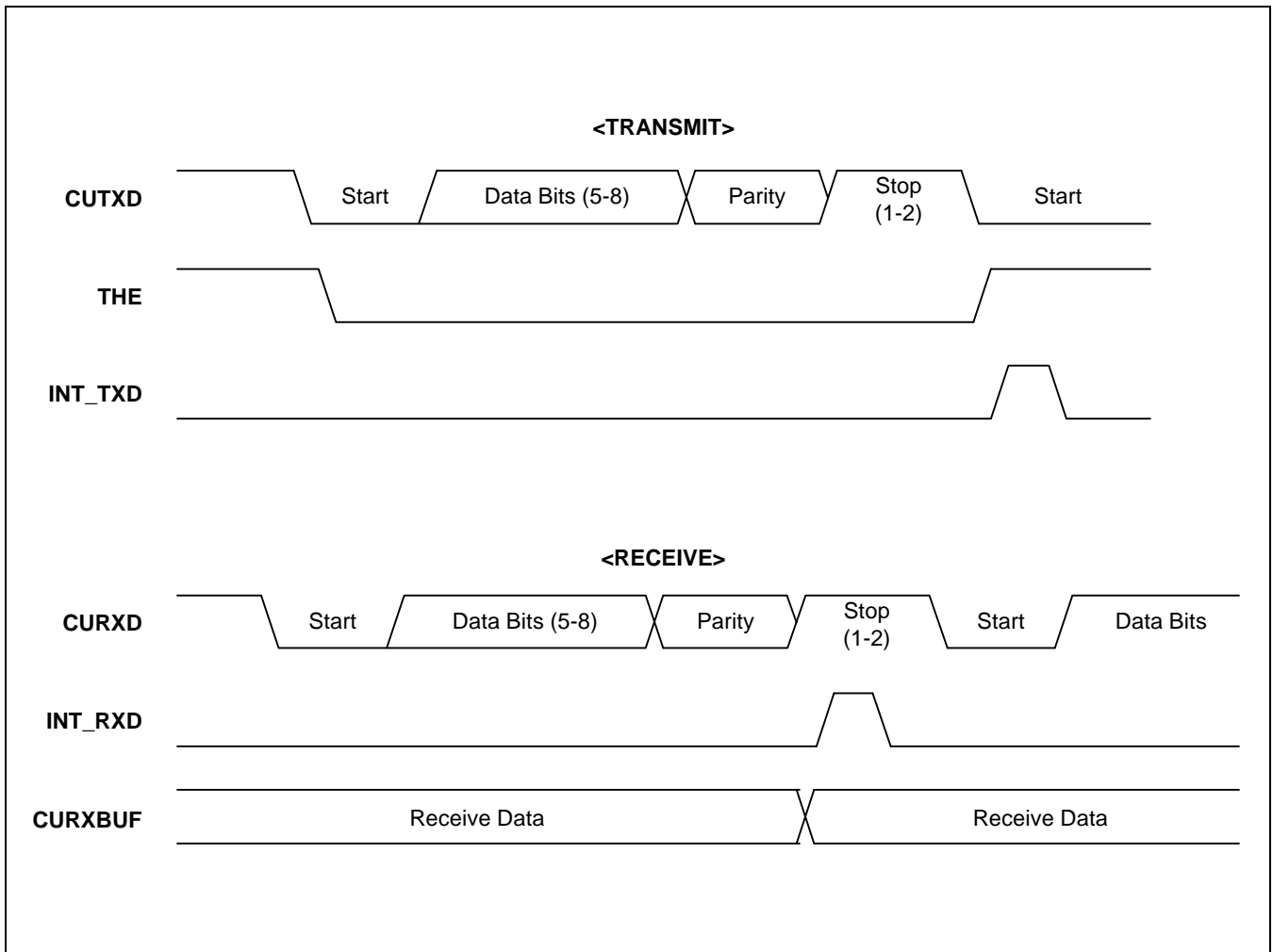

Figure 10-12. Interrupt-Based Serial I/O Transmit and Receive Timing Diagram

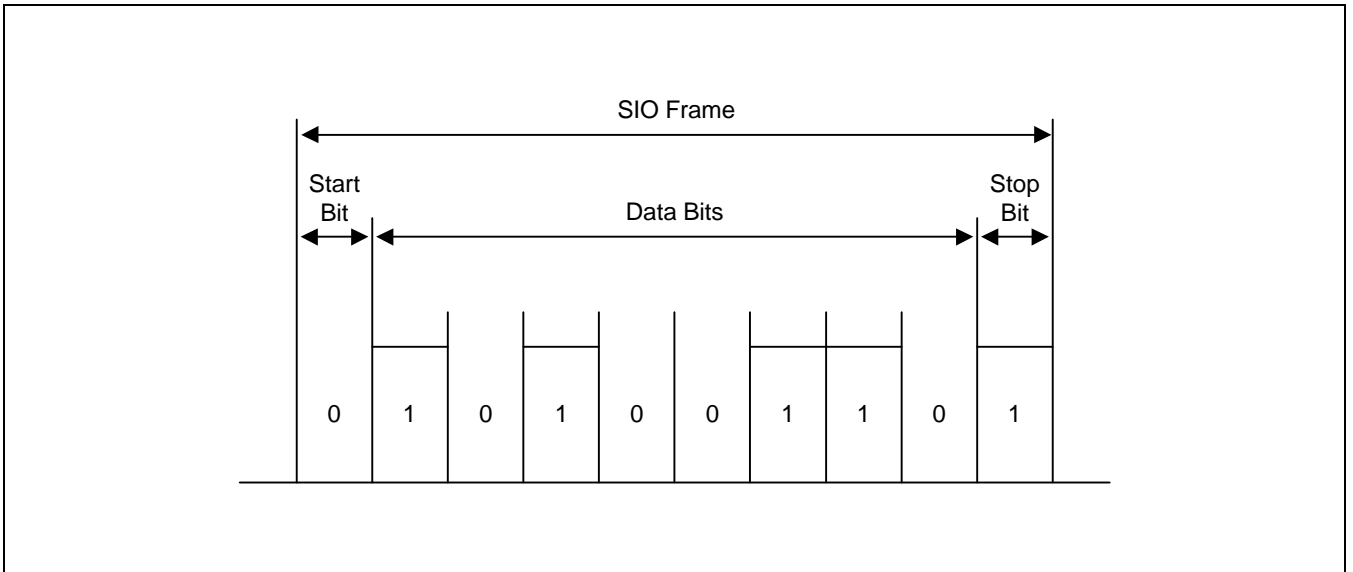

Figure 10-13. Serial I/O Frame Timing Diagram (Normal Console UART)

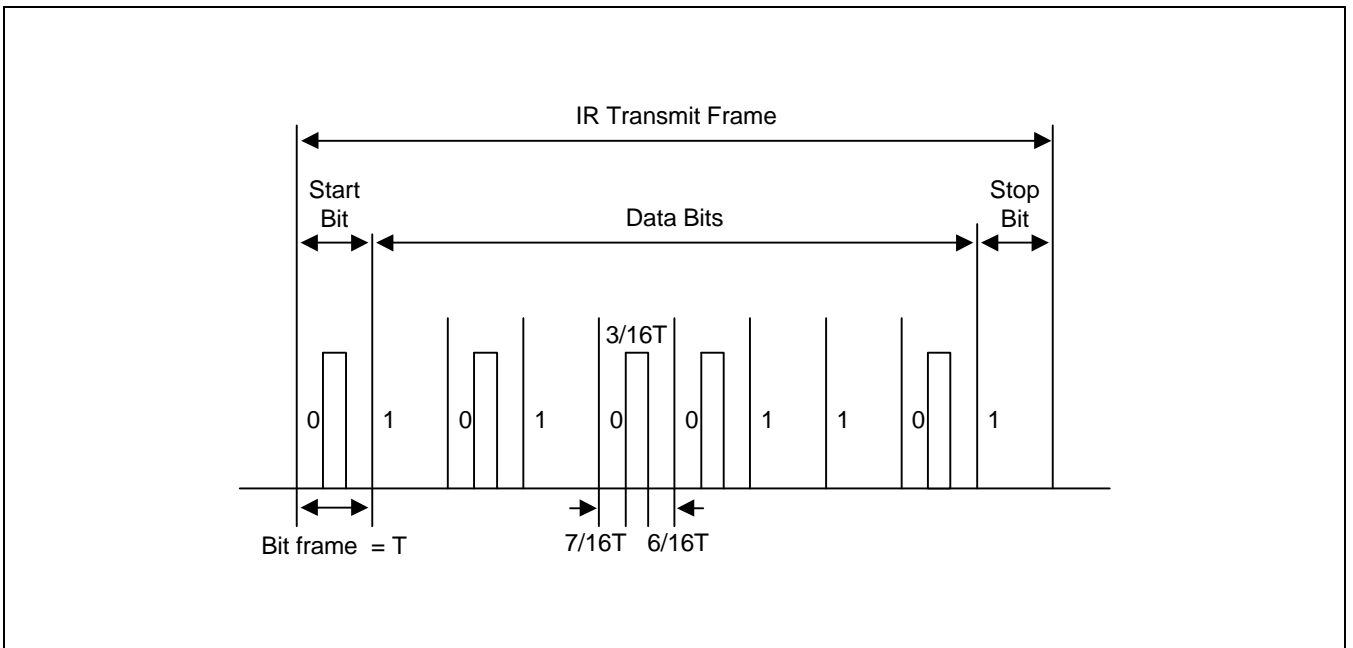

Figure 10-14. Infra-Red Transmit Mode Frame Timing Diagram

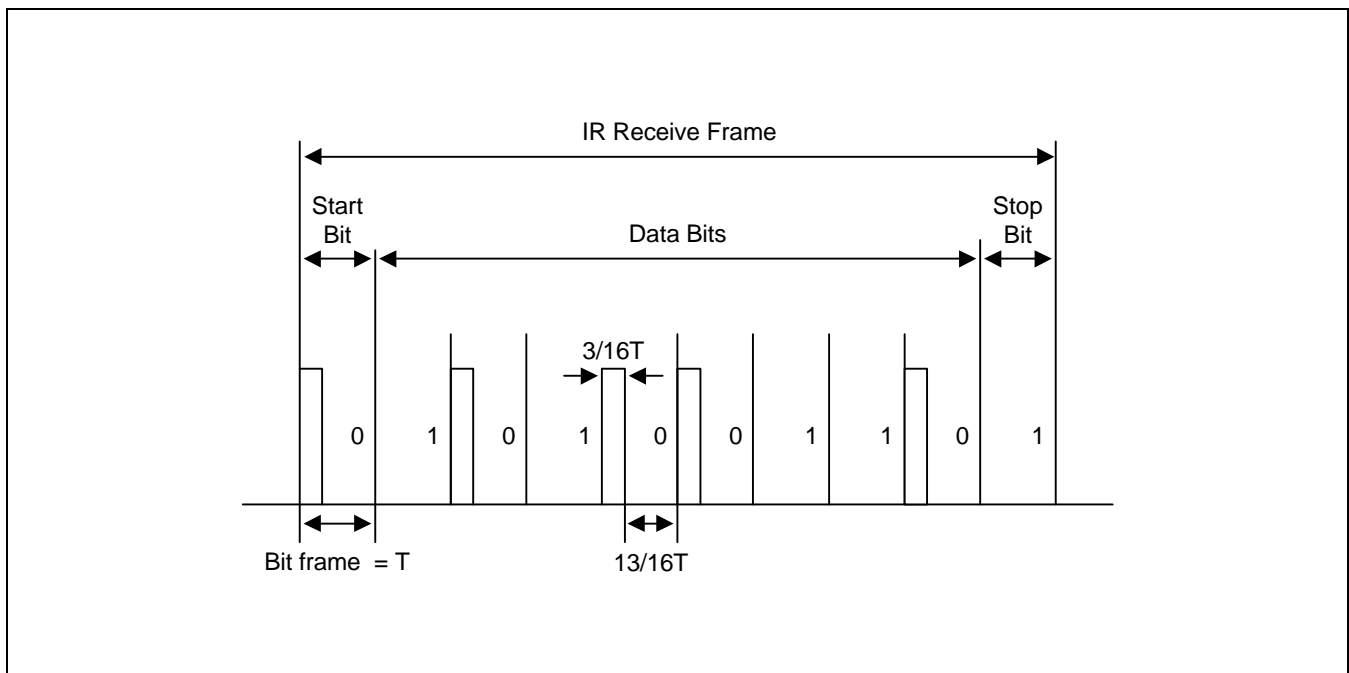

Figure 10-15. Infra-Red Receive Mode Frame Timing Diagram

11

SERIAL I/O (HIGH-SPEED UART)

11.1 OVERVIEW

The S3C2501X High-Speed UART (Universal Asynchronous Receiver/Transmitter) unit provides one independent asynchronous serial I/O (SIO) ports. High-Speed UART can operate in interrupt-based or DMA-based mode (DMA 3, 4, 5 for High-Speed UART channel). That is, the High-Speed UART can generate internal interrupts or DMA requests to transfer data between the CPU and the serial I/O ports.

11.2 FEATURES

The most important features of the S3C2501X High-Speed UART include:

- Programmable baud rates
- 32-byte Transmit FIFO and 32-byte Receive FIFO
- High-Speed UART source clock selectable (Internal clock: PCLK2, External clock : EXT_UCLK)
- $(PCLK2 = PCLK / 2)$
- Infra-red (IR) transmit/receive
- Insertion of one or two Stop bits per frame
- Selectable 5-bit, 6-bit, 7-bit, or 8-bit data transfers
- Parity checking

SIO unit has a baud rate generator, transmitter, receiver, and a control unit, as shown in Figure 11-1. The baud-rate generator can be driven by the internal system clock divided by 2, PCLK2, or by the external clock, EXT_UCLK. Auto Baud Rate Generator tries to get the baud rate from input data in this mode. The transmitter and receiver blocks have independent data buffer registers and data shifters. And 32-byte transmit FIFO and 32-byte receive FIFO is also provided which include transmit and receive buffer.

In non-FIFO mode, transmit data is written first to the transmit buffer register. From there, it is copied to the transmit shifter and then shifted out by the transmit data pin, HUTXD. Receive data is shifted in by the receive data pin, HURXD. It is then copied from the shifter to the receive buffer register when one data byte has been received.

Otherwise, you can select FIFO mode. In FIFO mode, transmitter and receiver use transmit FIFO and receive FIFO, instead of Tx/Rx buffer register(HUTXBUF/HURXBUF). They are controlled by each FIFO trigger level.

The SIO control units provide software controls for mode selection, and for status and interrupt generation.

In S3C2501X, software flow control or hardware flow control can be selected according to the application.

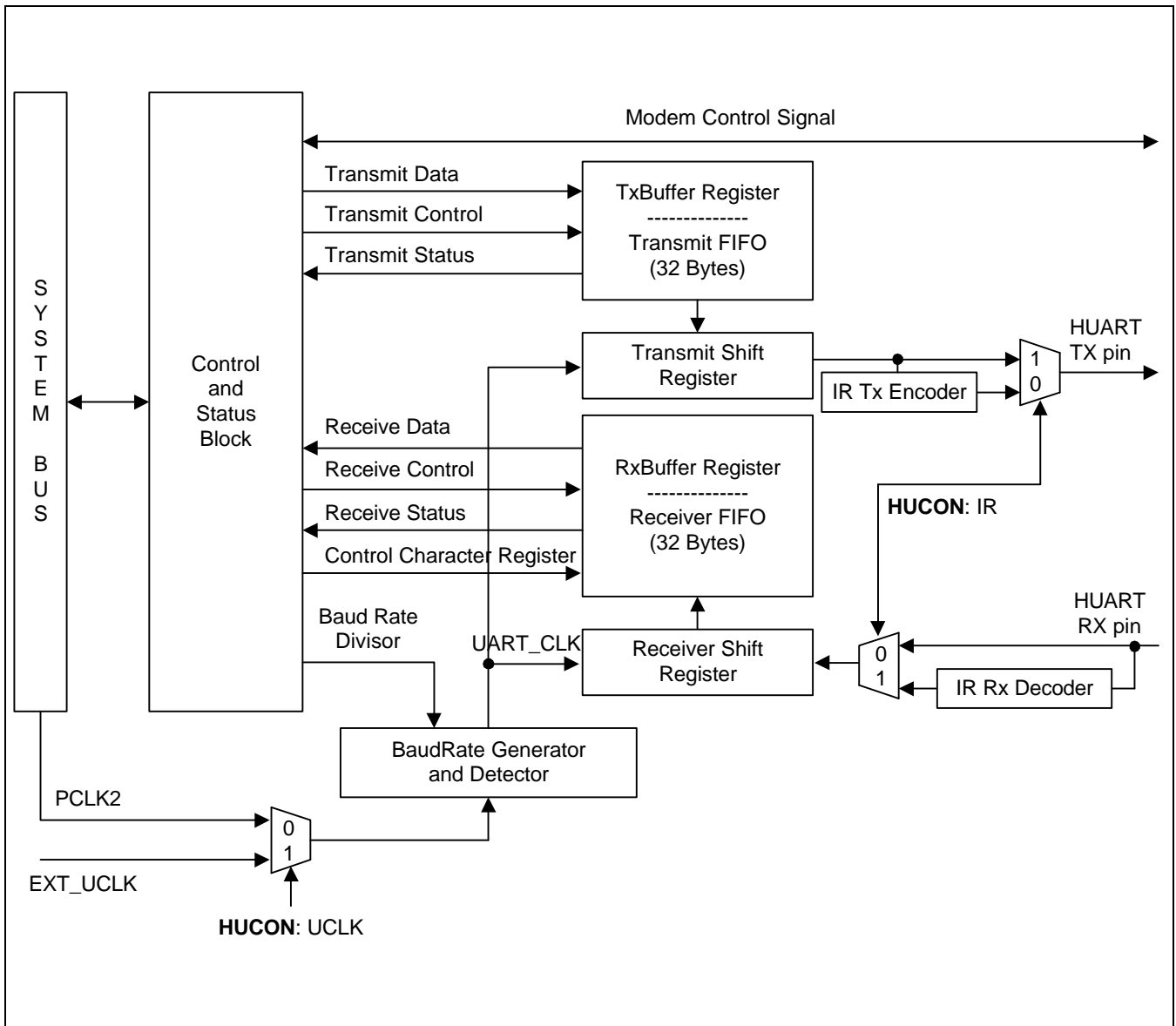

Figure 11-1. High-Speed UART Block Diagram

11.3 HIGH-SPEED UART SPECIAL REGISTERS

Table 11-1. High-Speed UART Special Registers Overview

Register	Address	R/W	Description	Size	Reset Value
HUCON	0xF0080000	R/W	High-Speed UART control register	W	0x00000000
HUSTAT	0xF0080004	R/W	High-Speed UART status register	W	–
HUINT	0xF0080008	R/W	High-Speed UART interrupt enable register	W	0x00000000
HUTXBUF	0xF008000C	W	High-Speed UART transmit data register	B	–
HURXBUF	0xF0080010	R	High-Speed UART receive data register	B	–
HUBRD	0xF0080014	R/W	High-Speed UART baud rate divisor register	H	0x00000000
HUCHAR1	0xF0080018	R/W	High-Speed UART control character register 1	W	0x00000000
HUCHAR2	0xF008001C	R/W	High-Speed UART control character register 2	W	0x00000000
HUABB	0xF0080020	R/W	High-Speed UART autobaud boundary register	W	0x170B0502
HUABT	0xF0080024	R/W	High-Speed UART autobaud table register	W	0x1F0F0703

11.3.1 HIGH-SPEED UART CONTROL REGISTERS

Table 11-2. High-Speed UART Control Register

Registers	Address	R/W	Description	Reset Value
HUCON	0xF0080000	R/W	High-Speed UART control register	0x00000000

Table 11-3. High-Speed UART Control Register Description

Bit Number	Bit Name	Description
[1:0]	Transmit mode (TMODE)	This two-bit value determines which function is currently able to write Tx data to the High-Speed UART transmit buffer register, HUTXBUF. 00 = Disable Tx mode. 01 = Interrupt request 10 = GDMA request 11 = Reserved (High-speed UART can use only GDMA 3,4,5 channel)
[3:2]	Receive mode (RMODE)	This two-bit value determine which function is currently able to read Rx data to the High-Speed UART receive buffer register, HURXBUF. NOTE: Changing these bits (TMODE, RMODE) while transmitting/receiving cause abnormal High-speed UART operation. To prevent Tx/Rx data from being lost, changing these bits while transmitting/receiving is strictly prohibited. 00 = Disable Rx mode. 01 = Interrupt request 10 = GDMA request 11 = Reserved (High-speed UART can use only GDMA 3,4,5 channel)
[4]	Send Break (SBR)	Set this bit to one to cause the High-Speed UART to send a break. If this bit value is zero, a break does not send. A break is defined as a continuous Low level signal on the transmit data output with the duration of more than one frame transmission time.
[5]	Serial Clock Selection (UCLK)	This selection bit specifies the clock source. 0 = Internal (PCLK2) 1 = External (EXT_UCLK)
[6]	Auto Baud Rate Detect (AUBD)	Setting this bit causes the High-Speed UART to enter Auto Baud Rate Detect mode. In this mode, High-Speed UART try to get the baud rate from input data. This bit automatically cleared when Auto Baud Rate Detection procedure is successfully finished.
[7]	Loop-back mode (LOOPB)	Setting this bit causes the High-Speed UART to enter Loop-back mode. In Loop-back mode, the transmit data output is sent High level and the transmit buffer register, HUTXBUF, is internally connected to the receive buffer register, HURXBUF. NOTE: This mode is provided for test purposes only. For normal operation, this bit should always be "0".
[10:8]	Parity mode (PMD)	The 3-bit parity mode value specifies how parity generation and checking are to be performed during High-Speed UART transmit and receive operations. 0xx = no parity 100 = odd parity 101 = even parity 110 = parity is forced/checked as a "1" 111 = parity forced/checked as a "0"

Table 11-3 High-Speed UART Control Register Description (Continued)

Bit Number	Bit Name	Description
[11]	Number of Stop bits (STB)	This bit specifies how many stop bits are used to signal end-of-frame (EOF). 0 = one stop bit per frame 1 = two stop bit per frame
[13:12]	Word Length (WL)	This two bit word length value indicates the number of data bits to be transmitted or received per frame. 00 = 5-bit 01 = 6-bit 10 = 7-bit 11 = 8-bit
[14]	Infra-red mode (IR)	The S3C2501X High-Speed UART block supports infra-red (IR) transmits and receives operations. In IR mode, the transmit period is pulsed at a rate of 3/16 that of the normal serial transmit rate (when the transmit data value in the HUTXBUF register is zero). To enable IR mode operation, you set HUCON[14] to "1". Otherwise, the High-Speed UART operates in normal mode. In IR receive mode, the receiver must detect the 3/16 pulsed period to recognize a zero value in the receiver buffer register, HURXBUF, as the IR receive data. When this bit is "0", normal High-Speed UART mode is selected. When it is "1", infra-red Tx/Rx mode is selected. NOTE: Changing this bit while transmitting cause one Tx data losing. Because level of infra-red frame start bit and idle state of normal frame are identically high.
[15]	Reserved	This bit should be cleared by zero.
[16]	Transmit FIFO enable (TFEN)	S3C2501X High-Speed UART block support 32-byte FIFO. If this bit set to one, transmit data moved to Tx FIFO and then sent.
[17]	Receive FIFO enable (RFEN)	S3C2501X High-Speed UART block support 32-byte FIFO. If this bit set to one, receive data moved to Rx FIFO. NOTE: Changing these bits (TFEN, RFEN) while transmitting/receiving sending/receiving unexpected data. To prevent this, changing these bits while transmitting/receiving is strictly prohibited.
[18]	Transmit FIFO reset (TFRST)	You set this bit to '1', transmit FIFO will be reset. In this case, if there is data in transmit shift register, it will be sent. NOTE: This bit will not cleared automatically.
[19]	Receive FIFO reset (RFRST)	You set this bit to '1', receive FIFO will be reset. In this case, if there is data in receive shift register, it will be received. NOTE: This bit will not cleared automatically.
[21:20]	Transmit FIFO trigger level (TFTL)	This two bit trigger level value determines when the transmitter start to transmit data in 32-byte transmit FIFO. 00 = 30-byte empty/32-byte 01 = 24/32 10 = 16/32 11 = 8/32
[23:22]	Receive FIFO trigger level (RFTL)	This two bit trigger level value determines when the receiver starts to move the received data in 32-byte receive FIFO. 00 = 1-byte valid/32-byte 01 = 8/32 10 = 18/32 11 = 28/32
[24]	Data Terminal Ready to pin (DTR)	This bit directly controls the HUnDTR pin. Setting this bit to one, the HUnDTR pin goes to Low level. If you set this bit to zero, it goes High level.

Table 11-3. High-Speed UART Control Register Description (Continued)

Bit Number	Bit Name	Description
[25]	Request to Send to pin (RTS)	This bit directly controls the High-Speed UART pin only when the High-Speed UART is not hardware flow control mode. If this bit set to one, High-Speed UART pin goes Low level. Otherwise, it remains High level.
[27:26]	Reserved	This bit should be cleared by zero.
[28]	Hardware Flow Control Enable (HFEN)	This bit determines whether High-Speed UART select hardware flow control or not. If this bit set to one, High-Speed UART will control all pins concerning to hardware flow control.
[29]	Software Flow Control Enable (SFEN)	This bit determines whether High-Speed UART select software flow control or not. If this bit set to one, High-Speed UART will act in software flow control. In this mode, you have to use Control Character register.
[30]	Echo Mode (ECHO)	If this bit is set to one, RX data is sent not only HURXBUF but also TX port directly, so HUTXBUF data will not be transmitted.
[31]	RTS/RTR selection (RTS/RTR)	This selection bit determines output of HUnRTS0/HUnRTS1 pin 0 = RTS 1 = RTR NOTE: In RxFIFO mode, RTR goes to '1' when RxFIFO is full, In NonRxFIFO mode, RTR goes to '1' when RxBUF is not empty.

31	30	29	28	27	26	25	24	23	22	21	20	19	18	17	16	15	14	13	12	11	10	8	7	6	5	4	3	2	1	0
R	E	S	H		R	D	R	R	T	R	T	R	T	R	T	I	W	S	P	L	L	A	S	S	R	R	M	T		
S	C	F	F		T	T	F	F	F	F	R	F	F	F	R	R	L	M	O	O	A	C	S	B	R	M	T			
R	H	E	E		S	R	T	T	T	S	S	N	N	S	S	R		D	O	O	B	S	S	R	M	T				
T	O	N	N				L	L	T	T	T	T	T	T																

[1:0] SIO transmit mode selection (TMODE)

00 = Disable
 01 = Interrupt request
 10 = GDMA request
 11 = Reserved

[3:2] SIO receive mode selection (RMODE)

00 = Disable
 01 = Interrupt request
 10 = GDMA request
 11 = Reserved

[4] Send Break (SBR)

0 = Send normal TxData 1 = Send Break signal

[5] Serial Clock Selection (SCSEL)

0 = Internal system clock divided 2 (PCLK2)
 1 = External UART clock (EXT_UCLK)

[6] Auto Baud Rate Detect (AUBD)

0 = Normal operating mode.
 1 = Auto Baud Rate Detect mode

[7] Loopback mode (LOOPB)

0 = Normal operating mode.
 1 = Enable Loopback mode (only for test)

[10:8] Parity mode (PMD)

0xx = No parity. 100 = Odd parity.
 101 = Even parity. 110 = Parity forced/checked as 1
 111 = Parity forced/checked as 0

[11] Stop Bits (STB)

0 = 1 stop bit 1 = 2 stop bits.

[13:12] Word Length (WL)

00 = 5-bit 01 = 6-bit
 10 = 7-bit 11 = 8-bit

[14] Infra-red mode (IR)

0 = normal operating mode.
 1 = Infra-red Tx/Rx mode

[15] Reserved (This bit should be cleared)

Figure 11-2. High-Speed UART Control Register

11.3.2 HIGH-SPEED UART STATUS REGISTERS

Table 11-4. High-Speed UART Status Register

Registers	Offset Address	R/W	Description	Reset Value
HUSTAT	0xF0080004	R/W	High-Speed UART status register	–

Table 11-5. High-Speed UART Status Register Description

Bit Number	Bit Name	Description
[0]	Receive Data Valid (RDV)	<p>This bit automatically set to one when Receive FIFO-top or HURXBUF contains a valid data received over the serial port. The received data can be read from Receive FIFO-top or HURXBUF . When this bit is "0", there is no valid data.</p> <p>According to the current setting of the High-Speed UART receive mode bits, an interrupt or DMA request is generated when HUSTAT[0]="1". In case of HUCON[3:2]="01" and HUINT[0], interrupt requested, and HUCON[3:2]="10" or "11", DMA request occurred.</p> <p>You can clear this bit by reading Receive FIFO or HURXBUF.</p> <p>NOTE: Whether Receive FIFO-top or HURXBUF depends on the HUCON[17].</p>
[1]	Break Signal Detected (BKD)	<p>This bit automatically set to one to indicate that a break signal has been received in Receive FIFO-top or HURXBUF.</p> <p>If the BSD interrupt enable bit, HUINT[1], is "1", a interrupt is generated when a break occurs.</p> <p>You can clear this bit by writing '1' to this bit.</p>
[2]	Frame Error (FER)	<p>This bit automatically set to "1" whenever a frame error occurs during a serial data receives operation. A frame error occurs when a zero is detected instead of the stop bit(s).</p> <p>If the FER interrupt enable bit, HUINT[2], is "1", a interrupt is generated when a frame error occurs.</p> <p>You can clear this bit by writing '1' to this bit.</p>
[3]	Parity Error (PER)	<p>This bit automatically set to "1" whenever a parity error occurs during a serial data receives operation. If the PER interrupt enable bit, HUINT[3], is "1", a interrupt is generated when a parity error occurs.</p> <p>You can clear this bit by writing '1' to this bit.</p>

Table 11-5. High-Speed UART Status Register Description (Continued)

Bit Number	Bit Name	Description
[4]	Overrun Error (OER)	This bit automatically set to "1" whenever an overrun error occurs during a serial data receives operation. When HURXBUF has a previous valid data, but a new received data is going to be written into HURXBUF during Non-FIFO mode and when a new received data is going to be written into RXFIFO with FIFO full during FIFO mode. HUSTAT[4] is set to "1". If the OER interrupt enable bit, HUINT[4], is "1", a interrupt is generated when a overrun error occurs. You can clear this bit by writing "1" to this bit.
[5]	Control Character Detect (CCD)	HUSTAT[5] is automatically set to "1" to indicate that a control character has been received. If the CCD interrupt enable bit, HUINT[5], is "1", an interrupt is generated when a control character is detected. You can clear this bit by writing "1" to this bit. NOTE: Software Flow Control mode does not affects Tx/Tx operation this bit . This bit informs only whether UART receives control character or not. Namely, if user want to stop Tx/Rx operation. User must program that routine.
[6]	Data carrier Detect Lost (DCDL)	This bit set to 1, if HUnDCD pin is high at the time High-Speed UART Receiver checks a newly received data whether the data is good frame or not. If the DCD interrupt enable bit, HUINT[6], is "1", a interrupt is generated when a data carrier is detected. This bit can be used for error check bit in hardware flow control mode.
[7]	Receive FIFO Data trigger level reach (RFREA)	In Receive FIFO mode, this bit indicates Receive FIFO has valid data and reaches Rx trigger level. So High-Speed UART request DMA to move data in Receive FIFO. In non-FIFO mode, if HURXBUF has a received data , this bit is set to '1' also, An interrupt or DMA request is generated when HUSTAT[7]="1". In case of HUCON[3:2]= "01" and HUINT[7]= "1",interrupt requested, and HUCON[3:2]= "10" or "11", DMA request occurred. You can clear this bit by reading Receive FIFO or HURXBUF with a good data. If any error, this bit is cleared by writing "1" to corresponding error bit in HUSTAT register.
[8]	Receive FIFO empty (RFEMT)	This bit is only for CPU to monitor High-Speed UART. When Receive FIFO is empty, this bit is set to "1". After reset, default value is "1".
[9]	Receive FIFO full (RFFUL)	This bit is only for CPU to monitor High-Speed UART. When Receive FIFO is full, this bit is set to '1'. After reset, default value is '0'
[10]	Receive FIFO overrun (RFOV)	This bit is set to "1" when Receive FIFO overrun occurs during the Receive FIFO mode. You can clear this bit by writing "1" to this bit.
[11]	Receiver in idle (RIDLE)	This bit is only for CPU to monitor the receiver state of High-Speed UART. The RxIDLE status bit indicates that the inactive state of RxDATA.

Table 11-5. High-Speed UART Status Register Description (Continued)

Bit Number	Bit Name	Description
[12]	Receive Event time out (E_RxTO)	<p>During Receive FIFO mode, if there is a valid data in HURXFIFO or Receive FIFO within a promised time interval which is determined according to WL(Word Length) , this bit is set to '1'. HURXFIFO is for non-FIFO mode and Receive FIFO is for FIFO mode.</p> <p>If the E_RxTO interrupt enable bit, HUINT[12], is "1", an interrupt is generated when a receive event time out is detected and valid data reside in HURXBUF or Receive FIFO. You can clear this bit by writing '1' to this bit.</p> <p>NOTE: Event time = WL*4 +12 This bit set to one when the Rx data resides in RxFIFO.</p>
[13]	AutoBaud Rate Detection (AUBDDN)	This bit is automatically set to "1" when High-Speed UART finishes AutoBaud Rate Detection procedure. You can clear this bit by writing "1" to this bit.
[14]	Data Set ready (DSR)	This bit is only for CPU to monitor High-Speed UART. When HUnDSR level is low, this bit is set. And HUnDSR high, this bit is cleared.
[15]	Clear To Send (CTS)	This bit is only for CPU to monitor High-Speed UART. When HUnCTS level is low , this bit is set. And HUnCTS high, this bit is cleared.
[16]	CTS Event occurred (E_CTS)	This bit is set to '1' whenever HUnCTS level changed. If the E_CTS interrupt enable bit, HUINT[16], is "1", a interrupt is generated when a CTS event is occurred. You can clear this bit by writing '1' to this bit.
[17]	Transmitter Idle (TI)	HUSTAT[17] is automatically set to '1' when the transmit holding register has no valid data to transmit and when the TX shift register is empty. The reset value is '1'
[18]	Transmit Holding Register Empty (THE)	<p>In Transmit FIFO mode, when Transmit FIFO is empty to trigger level, this bit set to '1'.</p> <p>In Non-FIFO mode, when HUTXBUF is empty without regarding Tx shift register , this bit set to '1'.</p> <p>An interrupt or DMA request is generated when HUSTAT[18] is "1". In case of HUCON[1:0]='01' and HUINT[18]=1, an interrupt requested, and HUCON[1:0]='10' or '11', DMA request occurred. You can clear this bit by writing TxDATA into HUTXBUF or Transmit FIFO.</p>
[19]	Transmit FIFO Empty (TFEMT)	This bit is only for CPU to monitor High-Speed UART. When Transmit FIFO is empty, this bit is set to '1'. After reset, default value is '1'
[20]	Transmit FIFO full (TFFUL)	This bit is only for CPU to monitor High-Speed UART. When Transmit FIFO is full, this bit is set to '1'. After reset, default value is '0' .
[31:21]	Reserved	Not applicable.

11.3.3 HIGH-SPEED UART INTERRUPT ENABLE REGISTER

Table 11-6. High-Speed UART Interrupt Enable Register

Registers	Offset Address	R/W	Description	Reset Value
HUINT	0xF0080008	R/W	High-Speed UART Interrupt Enable register	0x00

Table 11-7. High-Speed UART Interrupt Enable Register Description

Bit Number	Bit Name	Description
[0]	RDVIE	Receive Data Valid interrupt enable
[1]	BKDIE	Break Signal Detected interrupt enable
[2]	FERIE	Frame Error interrupt enable
[3]	PERIE	Parity Error interrupt enable
[4]	OERIE	Overrun Error interrupt enable
[5]	CCDIE	Control Character Detect interrupt enable
[6]	DCDLIE	DCD High at receiver checking time interrupt enable
[7]	RFREAIE	Receive FIFO Data trigger level reach interrupt enable
[9:8]	Reserved	
[10]	OVFFIE	Receive FIFO overrun interrupt enable
[11]	Reserved	
[12]	E_RxTOIE	Receive Event time out interrupt enable
[13]	AUBDDNIE	AutoBaud Rate Detection done interrupt enable
[15:14]	Reserved	
[16]	E_CTSIE	CTS Event occurred interrupt enable
[17]	TIIE	Transmitter Idle interrupt enable
[18]	THEIE	Transmit Holding Register Empty interrupt enable
[31:19]	Reserved	

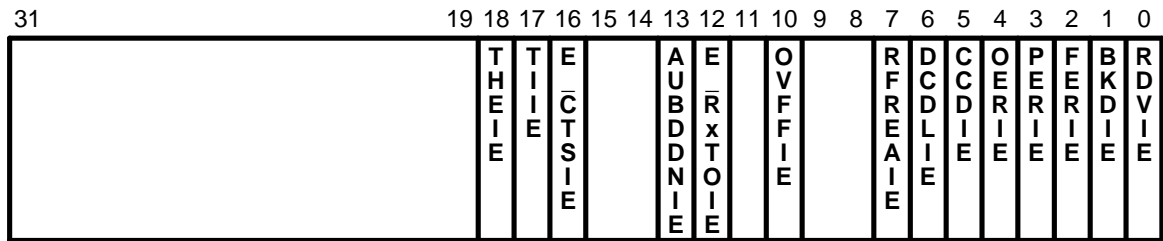

[0] Receive Data Valid Interrupt Enable (RDVIE)

[1] Break Signal Detected Interrupt Enable (BKDIE)

[2] Frame Error Interrupt Enable (FERIE)

[3] Parity Error Interrupt Enable (PERIE)

[4] Overrun error Interrupt Enable (OERIE)

[5] Control Character Detect Interrupt Enable (CCDIE)

[6] Data Carrier Detect Lost Interrupt Enable (DCDLIE)

[7] Receive FIFO Data Trigger Level Reach Interrupt Enable (RFREAIE)

[9:8] Reserved

[10] Receive FIFO overrun Interrupt Enable (OVFFIE)

[11] Reserved

[12] Receive Event Time out Interrupt Enable (E_RxTOIE)

[13] AutoBaud Rate Detection done interrupt enable (AUBDDNIE)

[15:14] Reserved

[16] CTS event occurred Interrupt Enable (E_CTSIE)

[17] Transmitter Idle (TIIE)

[18] Transmit Holding Register Empty Interrupt Enable (THEIE)
This bit used in FIFO mode for interrupt enable when transmit
FIFO empty as much transmit data trigger level.

[31:19] Reserved

Figure 11-4. High-Speed UART Interrupt Enable Register

11.3.4 HIGH-SPEED UART TRANSMIT BUFFER REGISTER

S3C2501X has a 32-byte Transmit FIFO, and the bottom of FIFO is HUTXBUF. All data to be transmitted are stored into this register at first in FIFO mode, if next buffer has invalid data, then shifted to next buffer. But in non-FIFO mode, a new data to transmit will be moved from HUTXBUF to Tx shift register. The High-Speed UART transmit buffer registers, HUTXBUF, contain an 8-bit data value to be transmitted over the High-Speed UART channel.

Table 11-8. High-Speed UART Transmit Register

Registers	Offset Address	R/W	Description	Reset Value
HUTXBUF	0xF008000C	W	High-Speed UART transmit buffer register	–

Table 11-9. High-Speed UART Transmit Register Description

Bit Number	Bit Name	Description
[7:0]	Transmit data	This field contains the data to be transmitted over the single channel High-Speed UART. When this register is written, the transmit buffer register empty bit in the status register, HUSTAT[18], should be "1". This is to prevent overwriting of transmit data that may already be present in the HUTXBUF. Whenever the HUTXBUF is written with a new value, the transmit register empty bit, HUSTAT[18], is automatically cleared to "0".

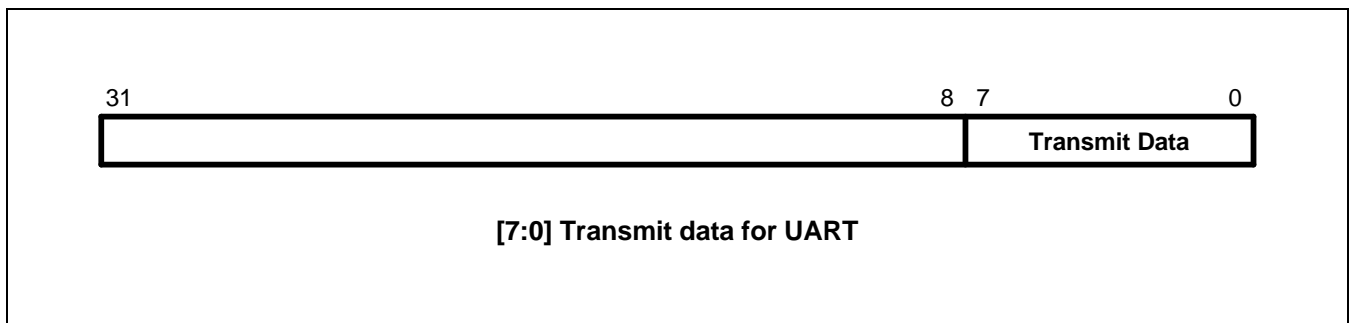

Figure 11-5. High-Speed UART Transmit Buffer Register

11.3.5 HIGH-SPEED UART RECEIVE BUFFER REGISTER

S3C2501X has a 32-byte Receive FIFO, and the bottom of FIFO is HURXBUF. All data to be received are stored in this register at first in FIFO mode, if next buffer has invalid data, then shifted to next buffer. But in Non-FIFO mode, a new received data will be moved to HURXBUF. The High-Speed UART receive buffer registers, HURXBUF contain an 8-bit data value to be received over the High-Speed UART channel.

Table 11-10. High-Speed UART Receive Register

Registers	Offset Address	R/W	Description	Reset Value
HURXBUF	0xF0080010	R	High-Speed UART receive buffer register	–

Table 11-11. High-Speed UART Receive Register Description

Bit Number	Bit Name	Description
[7:0]	Receive data	This field contains the data received over the single channel High-Speed UART. When the High-Speed UART finishes receiving a data frame, the receive data ready bit in the High-Speed UART status register, HUSTAT[14], should be "1". This prevents reading invalid receive data that may already be present in the HURXBUF. Whenever the HURXBUF is read, the receive data valid bit(HUSTAT[14]) is automatically cleared to "0".

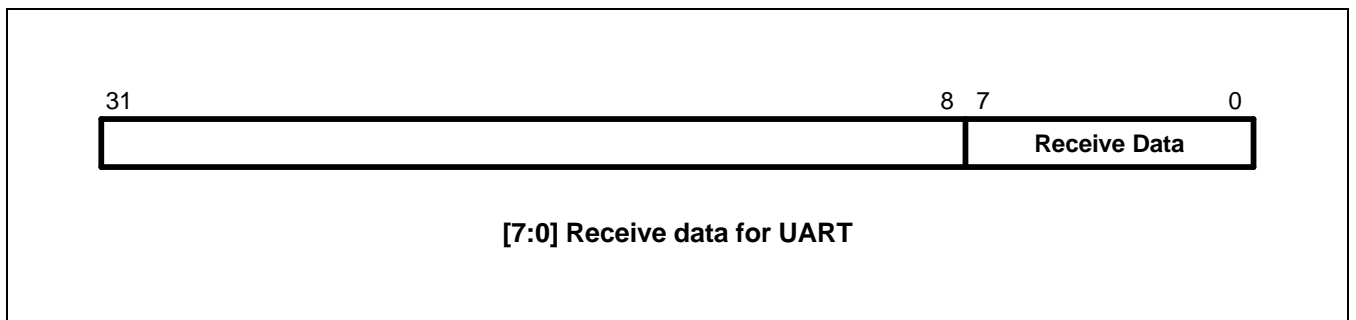

Figure 11-6. High-Speed UART Receive Buffer Register

11.3.6 HIGH-SPEED UART BAUD RATE DIVISOR REGISTER

The values stored in the baud rate divisor registers, HUBRD let you determine the serial Tx/Rx clock rate (baud rate) as follows:

$$BRGOUT = \frac{PCLK2 \text{ or } EXT_UCLK}{(CNT0+1) \times 16^{CNT1} \times 16}$$

Table 11-12. High-Speed UART Transmit Register

Registers	Offset Address	R/W	Description	Reset Value
HUBRD	0xF0080014	R/W	High-Speed UART baud rate divisor register	0x00

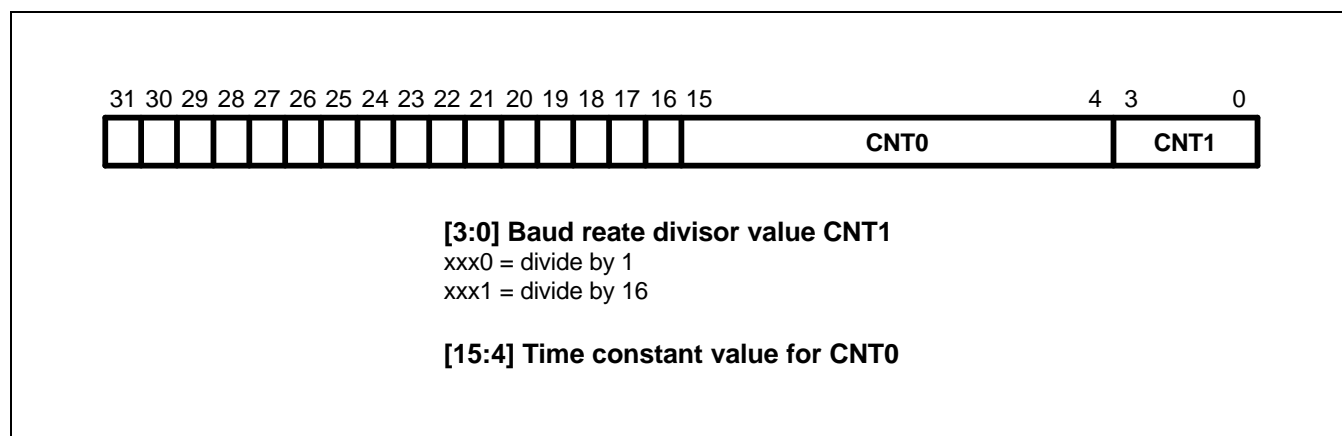

Figure 11-7. High-Speed UART Baud Rate Divisor Register

11.3.7 HIGH-SPEED UART BAUD RATE EXAMPLES

High-Speed UART BRG input clock, PCLK2 is the system clock frequency divided by 2.

If the system clock frequency is 133 MHz and PCLK2 is selected, the maximum BRGOUT output clock rate is PCLK2/16 (= 4,156,250 Hz).

EXT_UCLK is the external clock input pin for High-Speed UART, PCLK2, EXT_UCLK can be selected by HUCON[6] register.

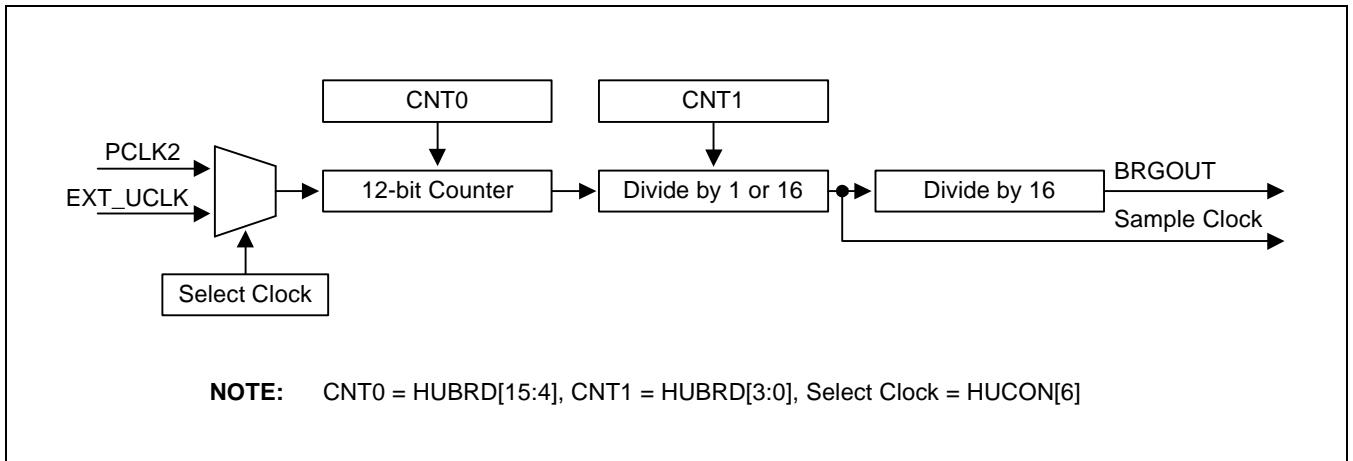

Figure 11-8. High-Speed UART Baud Rate Generator (BRG)

Table 11-13. Typical Baud Rates Examples of High-Speed UART

Baud Rates (BRGOUT)	PCLK2 = 66.5 MHz				EXT_UCLK = 29.4912 MHz			
	CNT0 (DEC/HEX)	CNT1	Freq.	Dev.(%)	CNT0 (DEC/HEX)	CNT1	Freq.	Dev.(%)
1200	3463/D87	0	1199.84	0.01	1535/5FF	0	1200.00	0.00
2400	1731/6C3	0	2399.68	0.01	767/2FF	0	2400.00	0.00
4800	865/361	0	4799.36	0.01	383/17F	0	4800.00	0.00
9600	432/160	0	9598.73	0.01	191/BF	0	9600.00	0.00
19200	215/D7	0	19241.90	0.01	95/5F	0	19200.00	0.00
38400	107/6B	0	38483.80	0.22	47/2F	0	38400.00	0.00
57600	71/47	0	57725.69	0.22	31/1F	0	57600.00	0.00
115200	35/23	0	115451.39	0.22	15/F	0	115200.00	0.00
230400	17/11	0	230902.78	0.22	7/7	0	230400.00	0.00
460800	8/8	0	461805.56	0.22	3/3	0	460800.00	0.00
921600	4/4	0	831250.00	9.80	1/1	0	921600.00	0.00

11.3.8 HIGH-SPEED UART CONTROL CHARACTER 1 REGISTER

This Control Character registers can be used for Software Flow control. In Software Flow Control mode, you should write control characters into this registers. If not, the reset value will be used as control character. For example, even if you want to use one control character, all control characters will have same value with it.

Table 11-14. High-Speed UART Control Charater 1 Register

Registers	Offset Address	R/W	Description	Reset Value
HUCHAR1	0xF0070018	R/W	High-Speed UART control character1 register	0x00

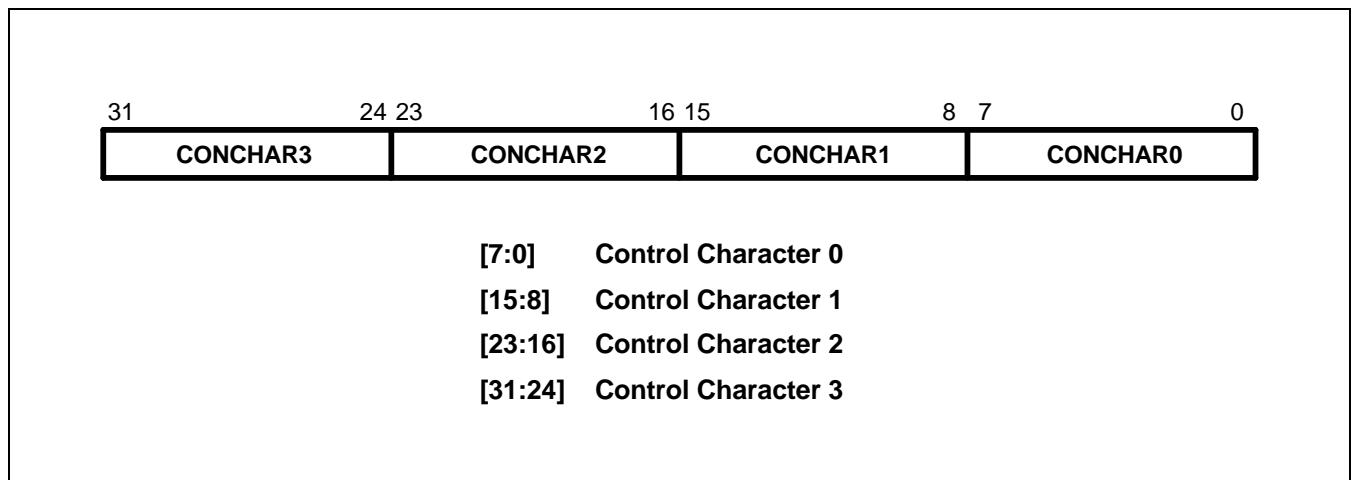

Figure 11-9. High-Speed UART Control Character 1 Register

11.3.9 HIGH-SPEED UART CONTROL CHARACTER 2 REGISTER

This Control Character registers can be used for Software Flow control. In Software Flow Control mode, you should write control characters into this registers. If not, the reset value will be used as control character. For example, even if you want to use one control character, all control characters will have same value with it.

Table 11-15. High-Speed UART Control Character 2 Register

Registers	Offset Address	R/W	Description	Reset Value
HUCHAR2	0xF008001C	R/W	High-Speed UART control character2 register	0x00

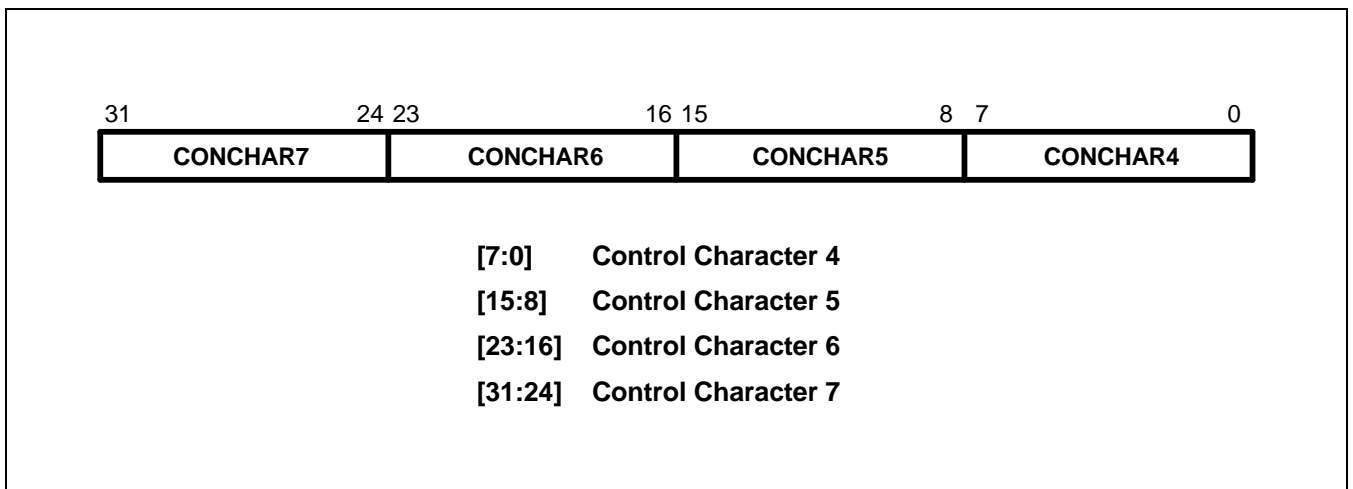

Figure 11-10. High-Speed UART Control Character 2 Register

11.3.10 HIGH-SPEED UART AUTOBAUD BOUNDARY REGISTER

This autobaud boundary register limit range of each baud rate value that is auto-detected. ABB0 is the lowest boundary value (high baud rate) and ABB3 is the highest value (low baud rate) of autobaud boundary register (actually the highest boundary value is ABT3). Refer figure 11-13 for detail range.

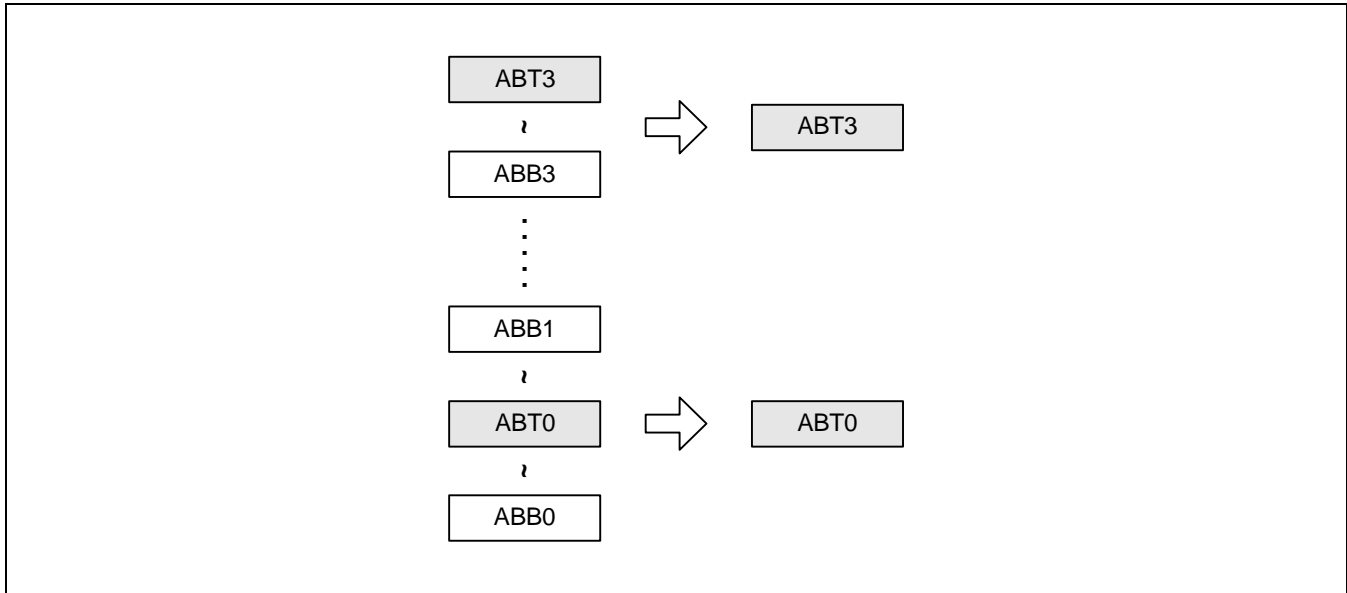

Figure 11-11. AutoBaud Boundary Register Range

Table 11-16. High-Speed UART AutoBaud Boundary Register

Registers	Offset Address	R/W	Description	Reset Value
HUABB	0xF0080020	R/W	High-Speed UART autobaud boundary register	0x170B0502

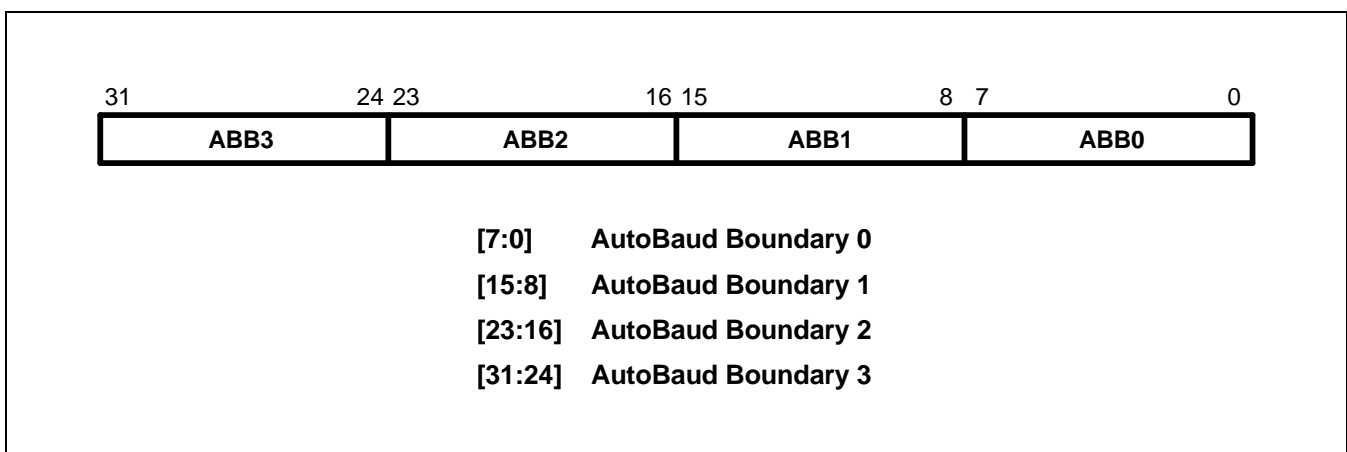

Figure 11-12. High-Speed UART AutoBaud Boundary Register

11.3.11 HIGH-SPEED UART AUTOBAUD TABLE REGISTER

This autobaud table register corrects each baud rate divisor value that is auto-detected. For detail refer figure 11-15. If high-speed UART uses external UCLK (29.4912 MHz) and you want to use 460800 baud rate, though high-speed UART detects baud rate divisor register value (CNT0, CNT1) as 0x04, autobaud mechanism will correct baud rate divisor register value as 0x03, because detected value is between 0x05 (ABB1) and 0x02 (ABB0). ABT0 is lowest table value and ABT3 is highest table value, also ABT3 is highest boundary value of total range. If out of range value is detected, it will be written normally without modification.

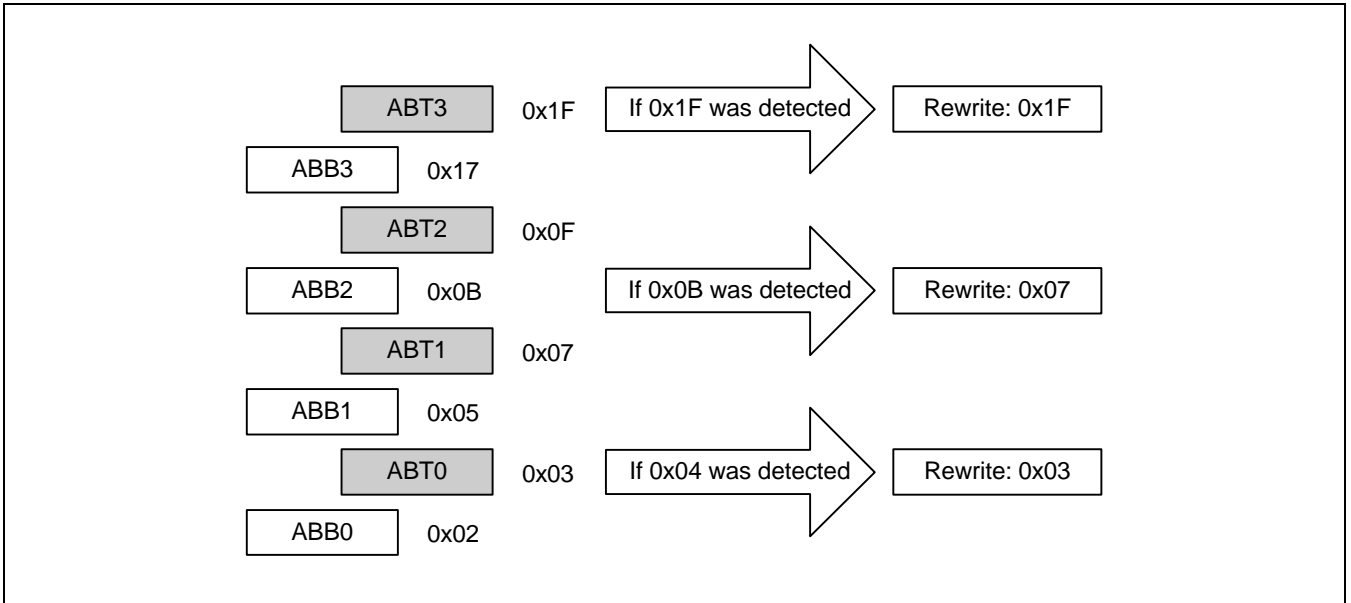

Figure 11-13. Example of AutoBaud Table Register Setting

Table 11-17. High-Speed UART AutoBaud Table Register

Registers	Offset Address	R/W	Description	Reset Value
HUABT	0xF0080024	R/W	High-Speed UART autobaud boundary register	0x1F0F0703

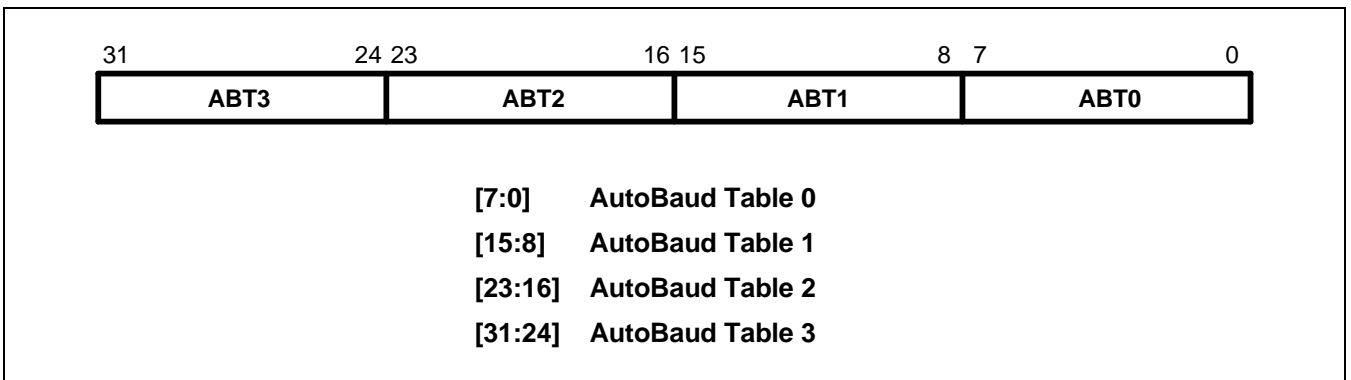

Figure 11-14. High-Speed UART AutoBaud Table Register

11.4 HIGH-SPEED UART OPERATION

Data Transmit Operation Flow:

If there is no data at Tx Buffer FIFO of High-Speed UART (in case of FIFO, if data in the Tx FIFO are empty as same amount of trigger level), High-Speed UART generates interrupt or GDMA request signal. It depends on High-Speed UART mode. CPU(or software) or GDMA controller will read data from memory where High-Speed UART transmit data are stored, and send them to Tx Buffer/FIFO. Transfer unit is byte. When data come from High-Speed UART Rx pin, data are stored to Rx Buffer/FIFO, via shift register. If valid Rx data are received, High-Speed UART generates interrupt or GDMA request signal. (Similar to Tx Block, in case of FIFO, it is same as Tx block. Data should be stored as the same level of trigger level.) If there is an error on Rx data, High-Speed UART does not generate GDMA request signal but generates interrupt even in case of GDMA mode. (Although High-Speed UART is FIFO mode, if error data shift to FIFO top, then High-Speed UART generates interrupt.) Transfer unit is byte, same as at Tx block.

11.4.1 FIFO OPERATION

Tx FIFO Operation:

If there is no valid data on trigger level of TX FIFO, High-Speed UART generates interrupt (INT_TXD) or sends a request signal to GDMA. During this operation trigger level should be 30/32 (empty depth/FIFO depth), 24/32, 16/32 or 8/32. CPU or GDMA fills data into TX FIFO by byte.

Rx FIFO Operation:

If received data are filled up to RX FIFO trigger level, High-Speed UART generate interrupt (INT_RXD) or send request signal to GDMA. The size of transferred data is 1 byte. If RX data contains error in case of GDMA mode operation, High-Speed UART generates interrupt instead of sending request signal to GDMA. Then CPU executes interrupt service routine for error data. So GDMA transmits (error free) valid data only from received data.

11.4.2 HARDWARE FLOW CONTROL

Hardware Flow Control for Transmit Operation:

When CTS signal level is high during Transmit operation - High-Speed UART transmits TX DATA to TX line normally.

When CTS signal level is low during Transmit operation - If CTS signal level is low when High-Speed UART transmits TX DATA to TX line, High-Speed UART stops data transmission immediately. In this case, transmitting TX data will be lost.

Hardware Flow Control for Receive Operation:

In the hardware flow control, during High-Speed UART receive data from Rx pin, DCD level have to be low. If DCD level goes high, received data will be pull up by High-Speed UART Rx block from that time.

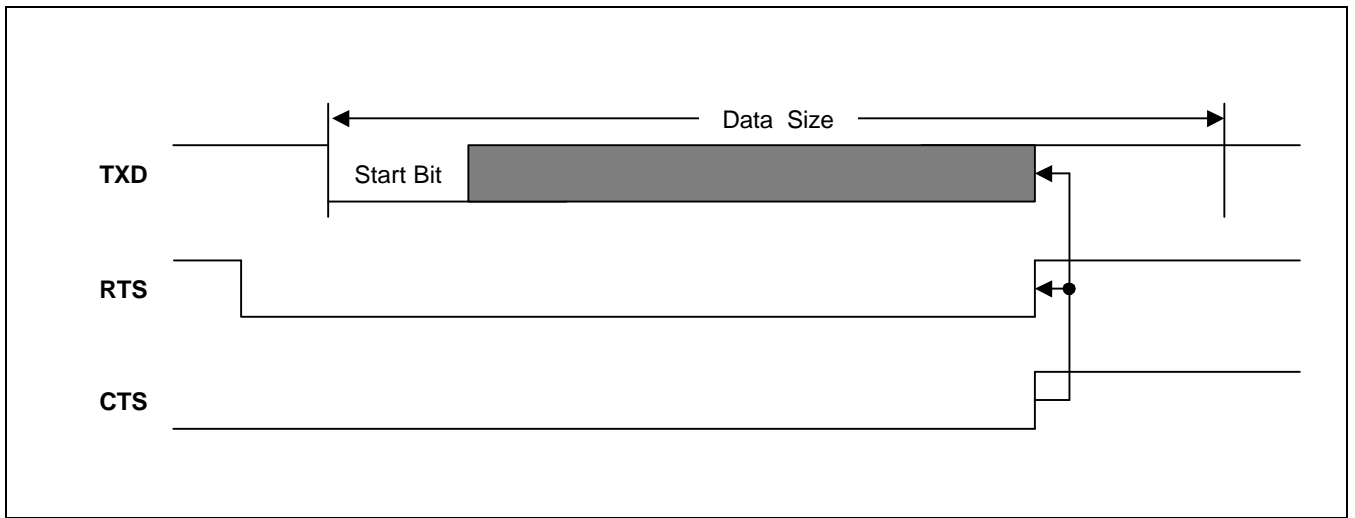

Figure 11-15. When CTS Signal Level is High During Transmit Operation

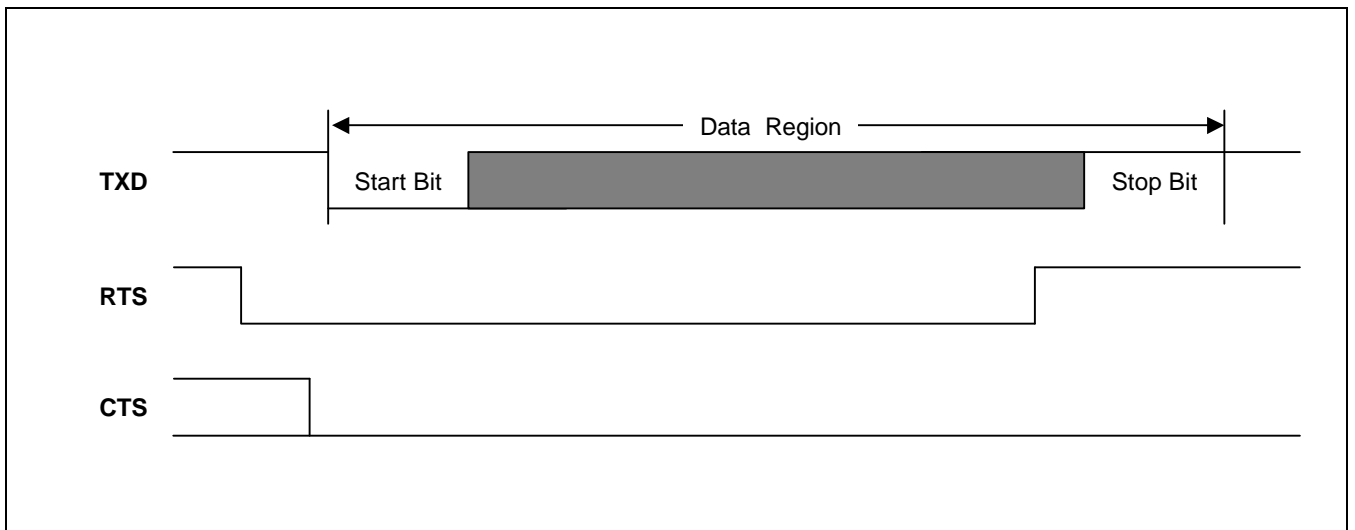

Figure 11-16. When CTS Signal Level is Low During Transmit Operation

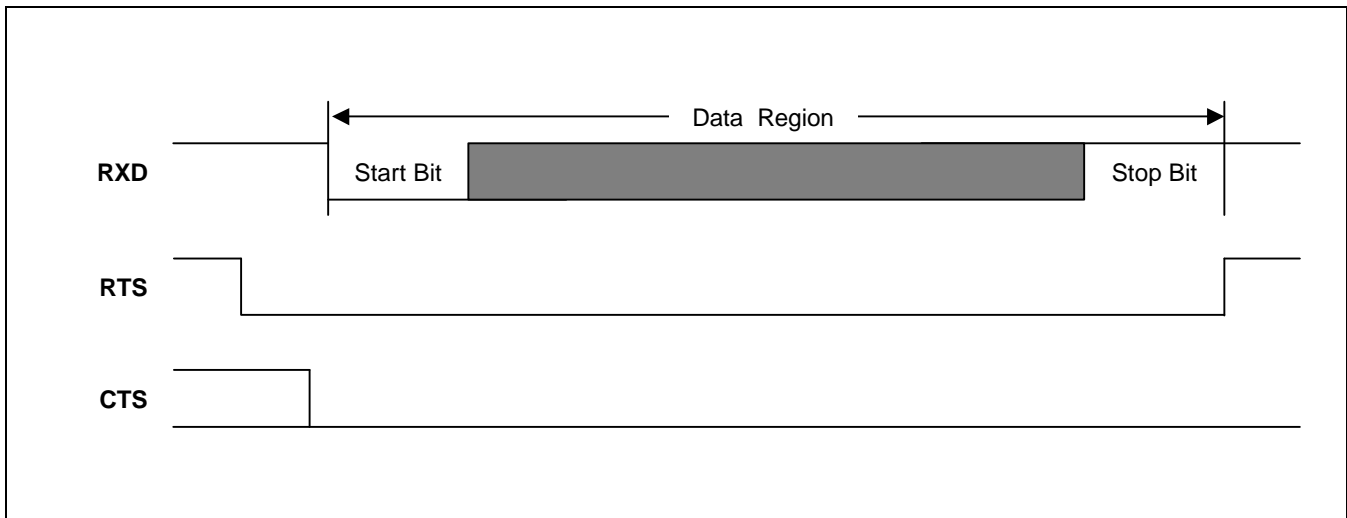

Figure 11-17. Normal Received Rx Data

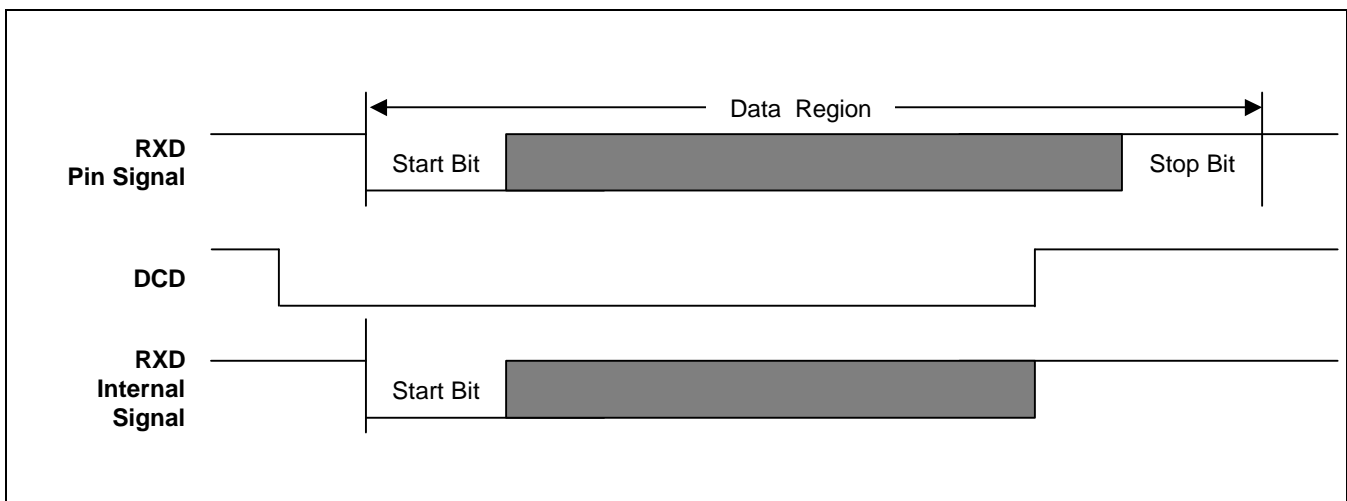

Figure 11-18. DCD Lost During Rx Data Receive

11.4.3 SOFTWARE FLOW CONTROL

Software can control High-Speed UART by control characters. High-Speed UART compares received data with control characters, and if they are identical, it sets "1" at state bit (CCD:HUSTAT[5]) and generates interrupt which masked by Interrupt enable register.

11.4.4 AUTO BAUD RATE DETECTION

To use Auto Baud Rate Detection, Set ABB(AutoBaud rate Boundary), ABT(AutoBaud rate Table) Register and Auto Baud Detect bit(AUBD:HUCON[6]), When RXD level is low, High-Speed UART counts low-level of start signal ('A') and rewrites counting value of low-level by comparing ABB, ABT Register. This automatically corrects Baud Rate(CNT0 and CNT1)

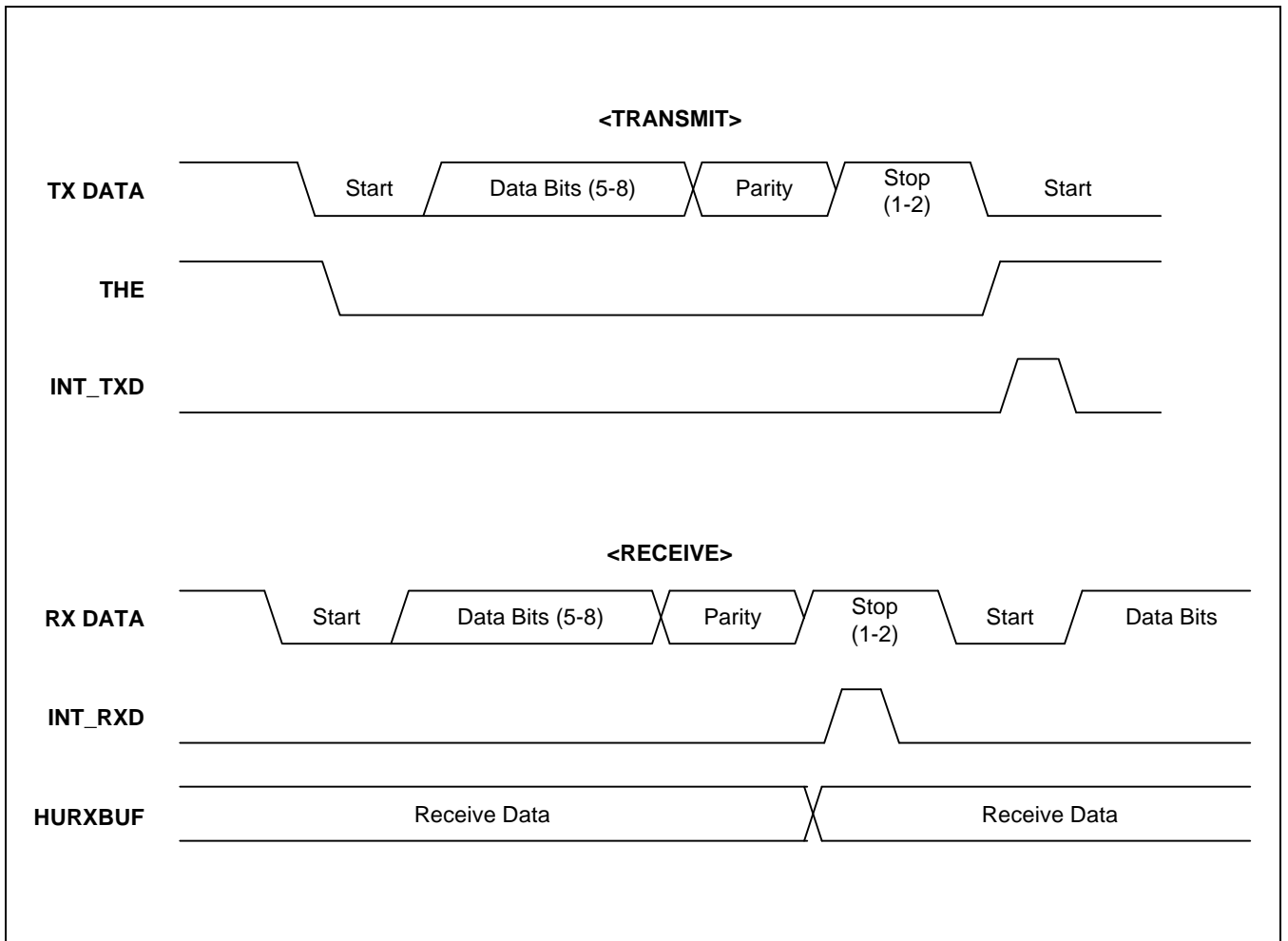

Figure 11-19. Interrupt-Based Serial I/O Transmit and Receive Timing Diagram

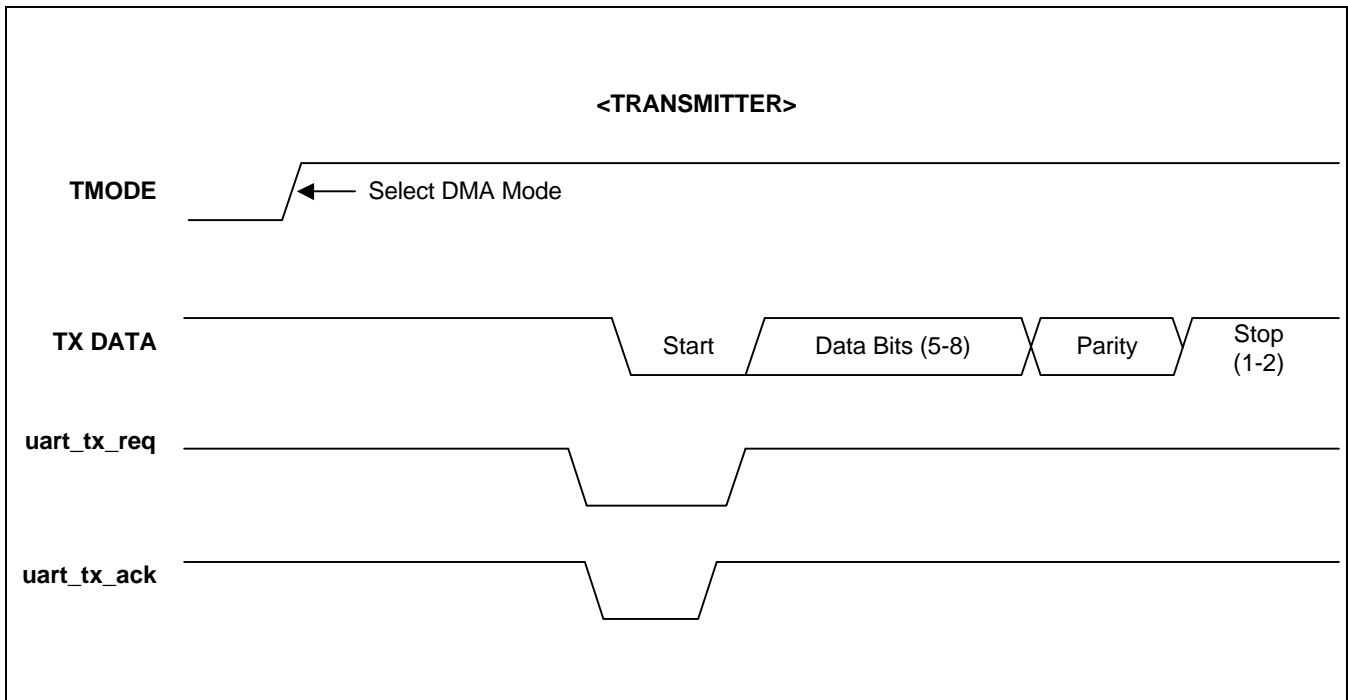

Figure 11-20. DMA-Based Serial I/O Timing Diagram (Tx Only)

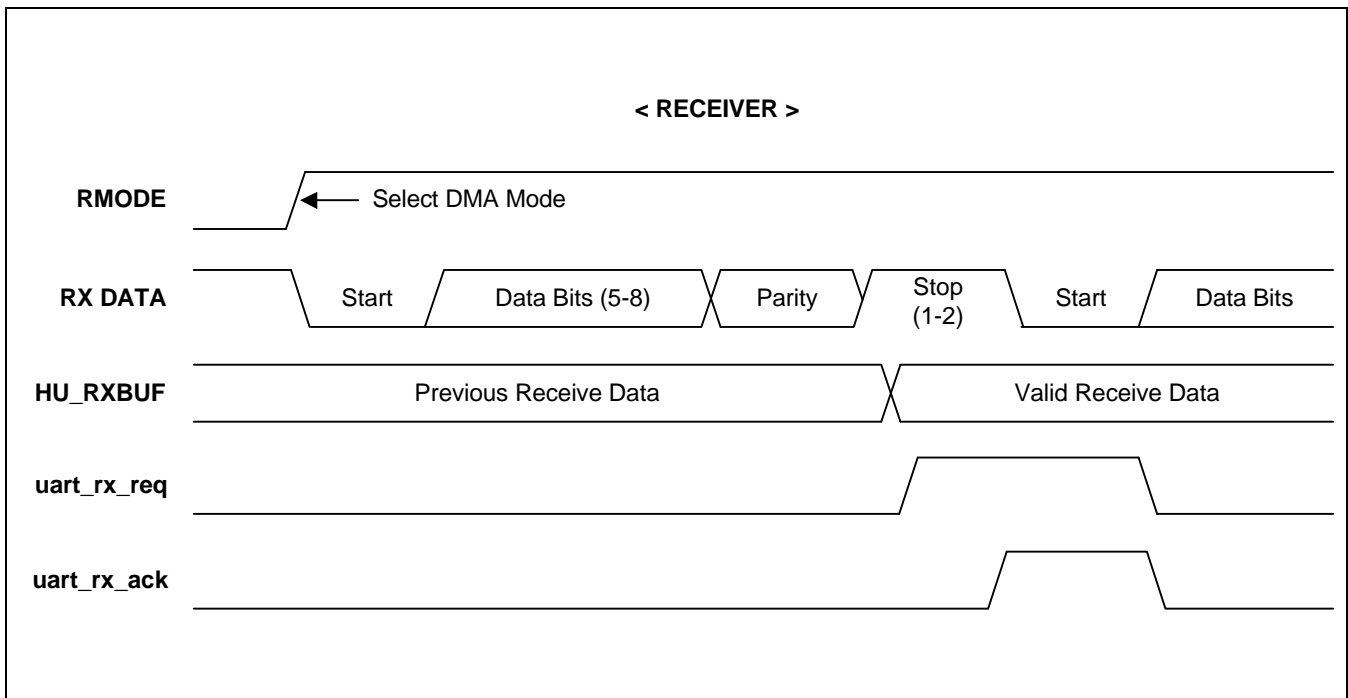

Figure 11-21. DMA-Based Serial I/O Timing Diagram (Rx Only)

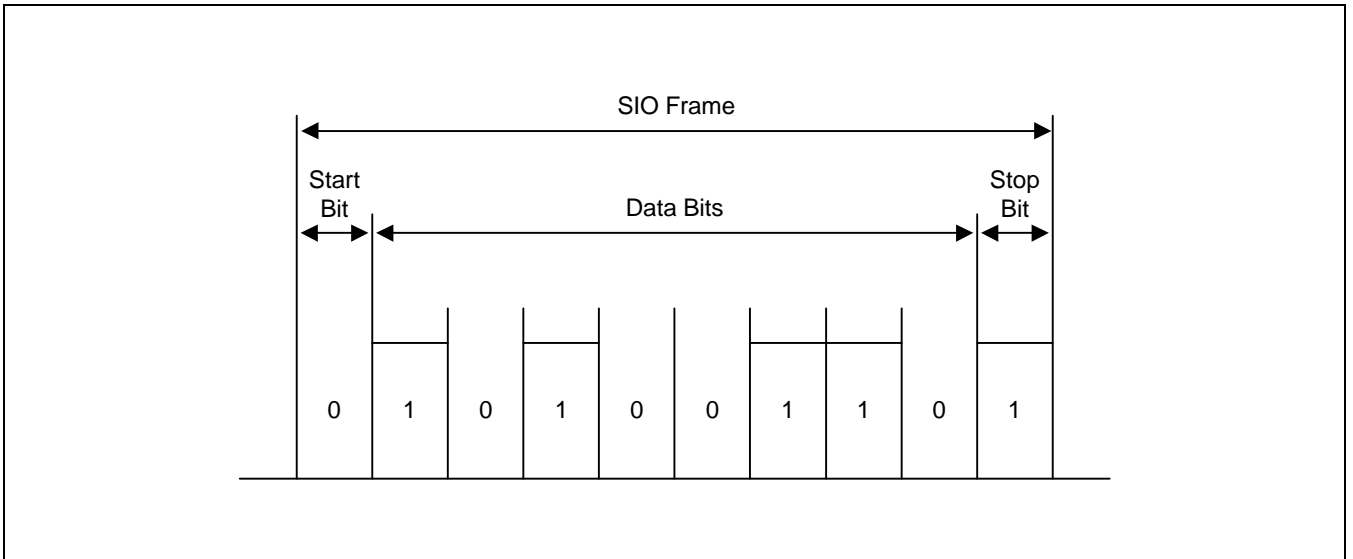

Figure 11-22. Serial I/O Frame Timing Diagram (Normal High-Speed UART)

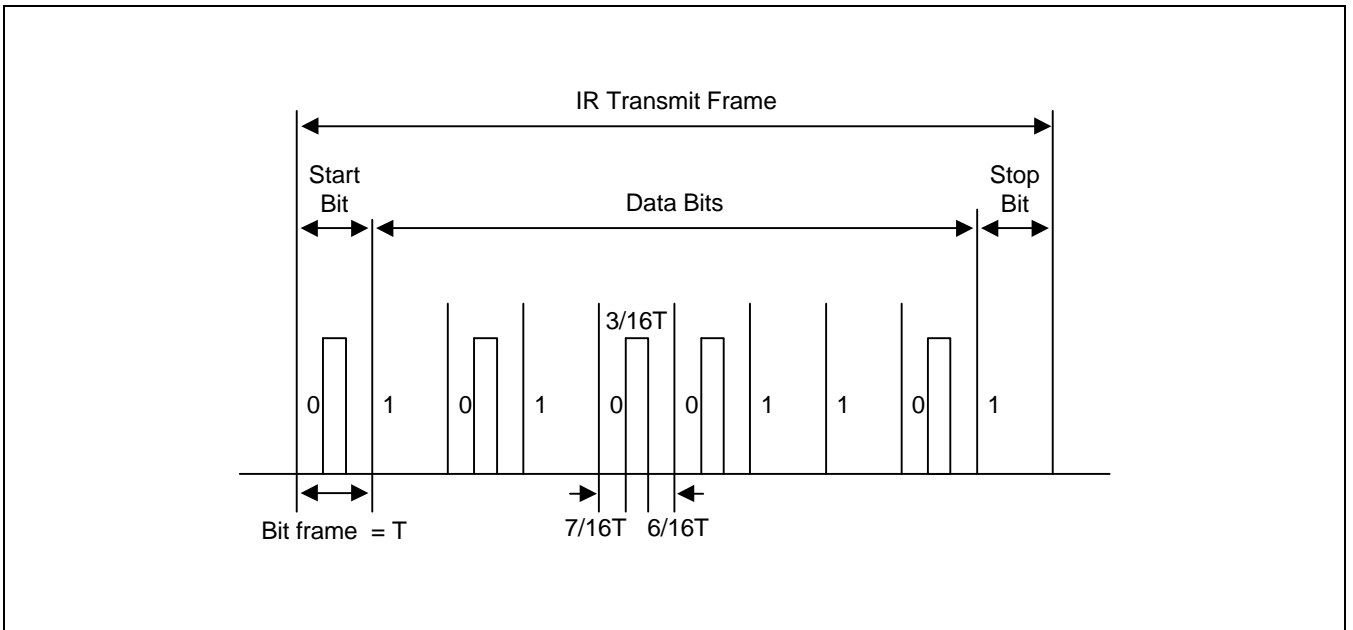

Figure 11-23. Infra-Red Transmit Mode Frame Timing Diagram

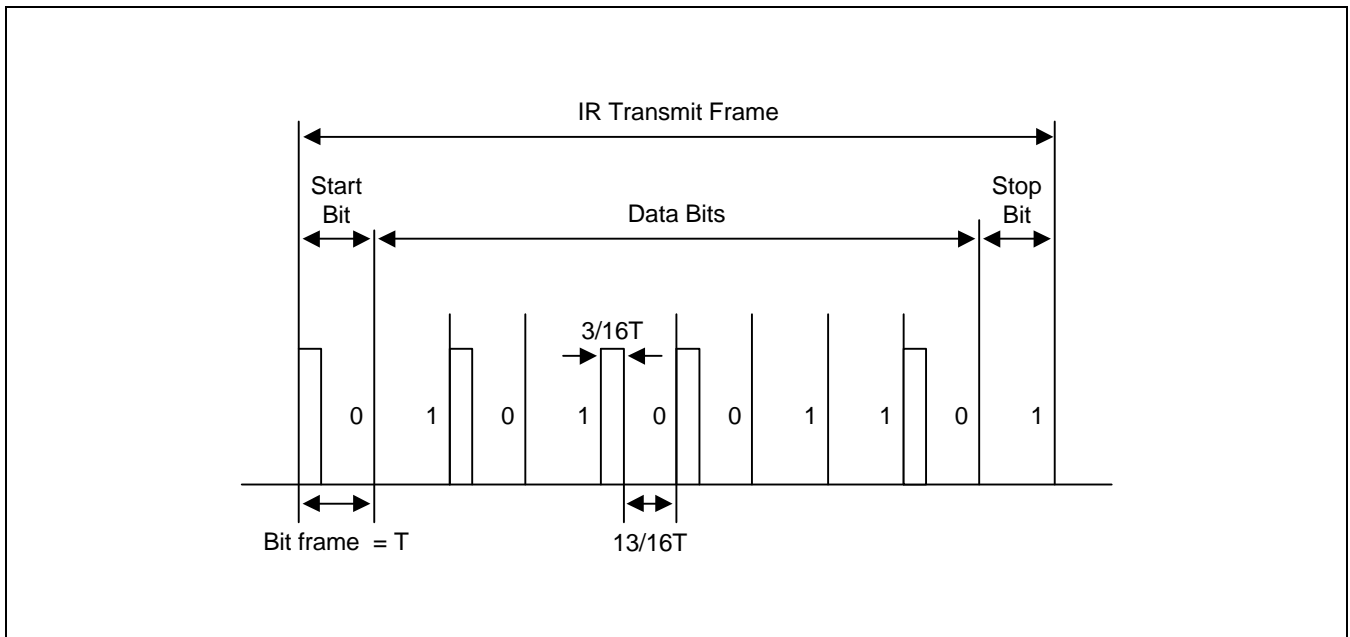

Figure 11-24. Infra-Red Receive Mode Frame Timing Diagram

12 I/O PORTS

12.1 OVERVIEW

S3C2501X has 64 programmable I/O ports. I/O port function control registers (IOPCON2: upper word, IOPCON1: lower word) select either function's port or GPIO. If IOPCON1/2 register is set to GPIO, IOPMODE1/2 register should be set to either input mode or output mode.

For example, if you select IOPCON1/2 for GPIO and IOPMODE1/2 for input, then I/O port can be used for GPIO input mode. When the value is latched in IOPDATA1/2 register, CPU can read IOPDATA1/2 register value. If you select IOPCON1/2 for GPIO and IOPMODE1/2 for output, then CPU can write the data to IOPDATA1/2 register and the value can be transferred to the output port.

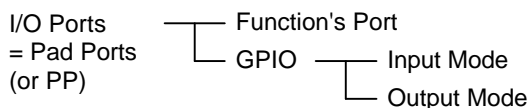

If you select IOPCON1[14] for xGDMA Req[0], then the port is used for GDMA Req port mode. I/O port signal decision register (IOPGDMA) is used when IOPCON1 is selected for GDMA Req/Ack. IOPGDMA controls external GDMA Req/Ack signals.

IOPEXTINTPND register is used for external interrupt status. IOPEXTINTPND is set when external interrupt is generated and is cleared when IOPEXTINTPND register is re-written to '1'.

12.2 FEATURES

- 64 Programmable I/O Ports
- Configurable to Input, Output, or I/O Mode for Dedicated Signals
- 6 External Interrupt Requests
- 4 External GDMA Requests
- 4 External GDMA Acknowledges
- 6 Timer Outputs
- 7 UART Signals

NOTE

PP[27] - PP[18] ports support external software reset. When PP[27:18] are in GPIO output mode and when nRESET or System Reset (including watchdog reset) is asserted, the external devices that are connected to PP[27:18] are also reset. (That is, the output signals stay high, and fall back to low.)

12.3 I/O PORT SPECIAL REGISTER

Table 12-1. I/O Port Special Registers

Register	Address	R/W	Description	Reset Value
IOPMODE1	0xF0030000	R/W	I/O port mode select register for port 0 to 31	0xF003FFFF
IOPMODE2	0xF0030004	R/W	I/O port mode select register for port 32 to 63	0xFFFFFFFF
IOPCON1	0xF0030008	R/W	I/O port function control register for port 0 to 31	0xFFFFFFFF00
IOPCON2	0xF003000C	R/W	I/O port function control register for port 32 to 63	0xFFFFFFFFC07
IOPGDMA	0xF0030010	R/W	I/O port special function register for GDMA	0x00000000
IOPEXTINT	0xF0030014	R/W	I/O port special function register for external interrupt	0x00000000
IOPEXTINT PND	0xF0030018	R/W	I/O port external interrupt clear register	0x00000000
IOPDATA1	0xF003001C	R/W	I/O port data register for port 0 to 31	Undefined
IOPDATA2	0xF0030020	R/W	I/O port data register for port 32 to 63	Undefined
IOPDRV1	0xF0030024	R/W	I/O port drive control register for port 0 to 31	0x00000000
IOPDRV2	0xF0030028	R/W	I/O port drive control register for port 32 to 63	0x00000000

12.3.1 I/O PORT MODE SELECT REGISTER (IOPMODE1/2)

If you set IOPCON1/2 registers to GPIO, then IOPMODE1/2 registers should determine whether input or output mode for each port.

Table 12-2. IOPMODE1/2 Registers

Register	Address	R/W	Description	Reset Value
IOPMODE1	0xF0030000	R/W	I/O port mode select register for port 0 to 31	0xF003FFFF
IOPMODE2	0xF0030004	R/W	I/O port mode select register for port 32 to 63	0xFFFFFFFF

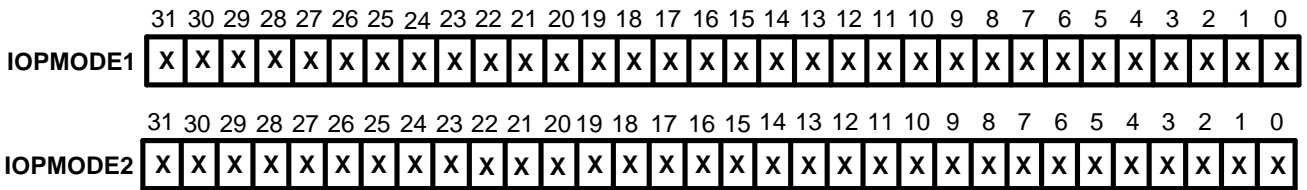

NOTE: IOPMODE1/2 registers bit value 1 is input mode, bit value 0 is output mode.

See NOTE on Page 12-1.

Bit	IOPMODE1		IOPMODE2	
	Signal port	Reset value	Signal port	Reset value
31	GPIO[31]	1	GPIO[63]	1
30	GPIO[30]	1	GPIO[62]	1
29	GPIO[29]	1	GPIO[61]	1
28	GPIO[28]	1	GPIO[60]	1
27	GPIO[27]	0	GPIO[59]	1
26	GPIO[26]	0	GPIO[58]	1
25	GPIO[25]	0	GPIO[57]	1
24	GPIO[24]	0	GPIO[56]	1
23	GPIO[23]	0	GPIO[55]	1
22	GPIO[22]	0	GPIO[54]	1
21	GPIO[21]	0	GPIO[53]	1
20	GPIO[20]	0	GPIO[52]	1
19	GPIO[19]	0	GPIO[51]	1
18	GPIO[18]	0	GPIO[50]	1
17	GPIO[17]	1	GPIO[49]	1
16	GPIO[16]	1	GPIO[48]	1
15	GPIO[15]	1	GPIO[47]	1
14	GPIO[14]	1	GPIO[46]	1
13	GPIO[13]	1	GPIO[45]	1
12	GPIO[12]	1	GPIO[44]	1
11	GPIO[11]	1	GPIO[43]	1
10	GPIO[10]	1	GPIO[42]	1
9	GPIO[9]	1	GPIO[41]	1
8	GPIO[8]	1	GPIO[40]	1
7	GPIO[7]	1	GPIO[39]	1
6	GPIO[6]	1	GPIO[38]	1
5	GPIO[5]	1	GPIO[37]	1
4	GPIO[4]	1	GPIO[36]	1
3	GPIO[3]	1	GPIO[35]	1
2	GPIO[2]	1	GPIO[34]	1
1	GPIO[1]	1	GPIO[33]	1
0	GPIO[0]	1	GPIO[32]	1

Figure 12-1. I/O Port Mode Registers 1/2 (IOPMODE1/2)

12.3.2 I/O PORT FUNCTION CONTROL REGISTER (IOPCON1/2)

The I/O port function select registers, IOPCON1/2, are used for function select. IOPCON1/2 are used to configure external interrupt signals, GDMA Req/Ack signals, timer signals and UART Tx/Rx signals. For example, if you set IOPCON1[14] to '0', then port14 is used for GDMA Req port. If you set the IOPGDMA[14] to '1', then port14 is used for GPIO.

NOTE

If the port is used for a function's port such as an external interrupt request or an external GDMA Req/Ack signal, its signal function is determined by IOPGDMA or IOPEXTINT register.

Table 12-3. IOPCON1/2 Register

Register	Address	R/W	Description	Reset Value
IOPCON1	0xF0030008	R/W	I/O port function control register for port 0 to 31	0xFFFFFFFF00
IOPCON2	0xF003000C	R/W	I/O port function control register for port 32 to 63	0xFFFFFFFFC07

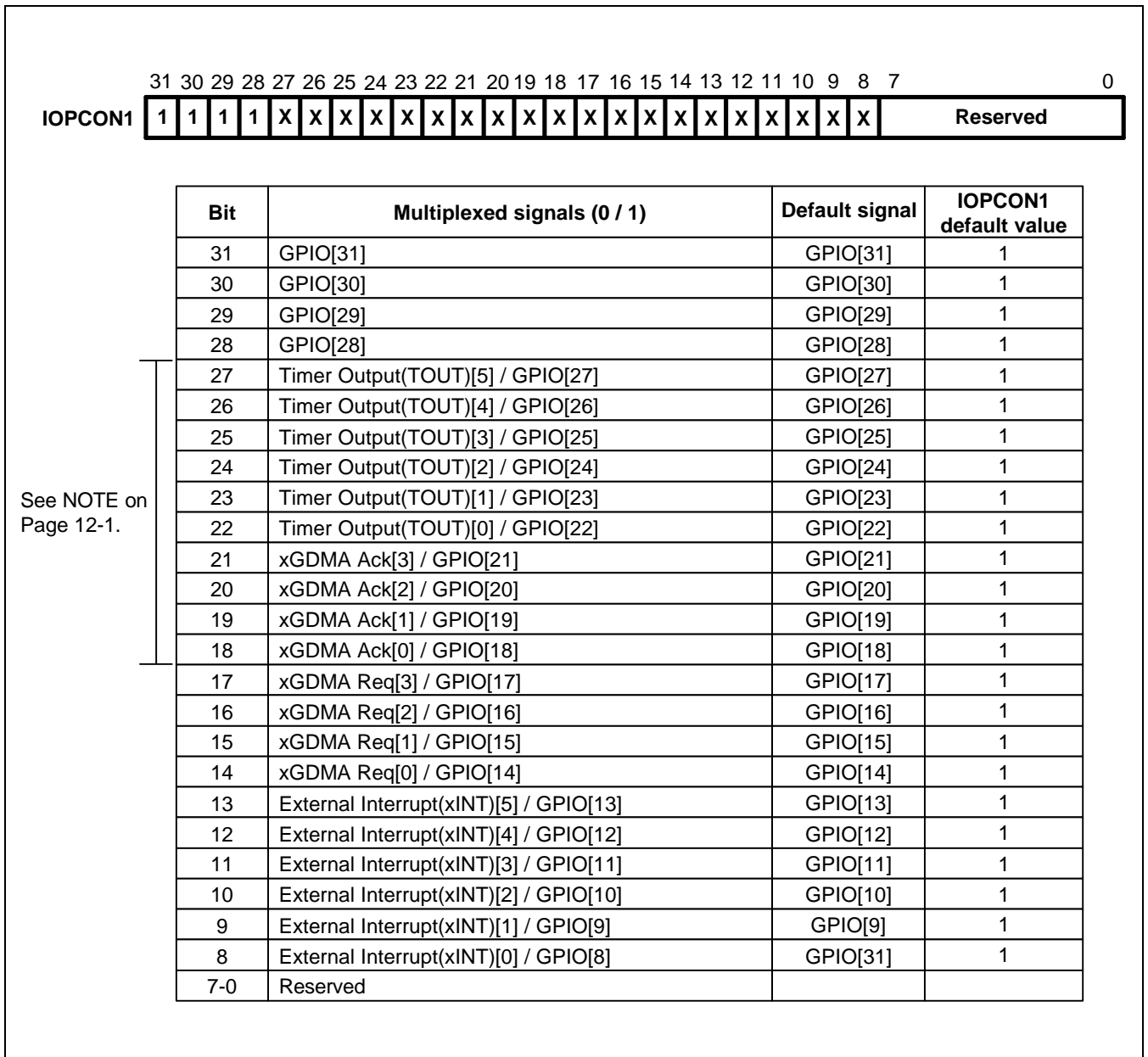

Figure 12-2. I/O Function Control Register 1 (IOPCON1)

IOPCON2 31 30 29 28 27 26 25 24 23 22 21 20 19 18 17 16 15 14 13 12 11 10 9 8 7 6 5 4 3 2 1 0
 1 1 1 1 1 1 1 1 1 1 1 1 1 1 1 1 1 1 1 1 1 1 X X X X X X X 1 1 1

Bit	Multiplexed signals (0 / 1)	Default signal	IOPCON2 default value
31	GPIO[63]	GPIO[63]	1
30	GPIO[62]	GPIO[62]	1
29	GPIO[61]	GPIO[61]	1
28	GPIO[60]	GPIO[60]	1
27	GPIO[59]	GPIO[59]	1
26	GPIO[58]	GPIO[58]	1
25	GPIO[57]	GPIO[57]	1
24	GPIO[56]	GPIO[56]	1
23	GPIO[55]	GPIO[55]	1
22	GPIO[54]	GPIO[54]	1
21	GPIO[53]	GPIO[53]	1
20	GPIO[52]	GPIO[52]	1
19	GPIO[51]	GPIO[51]	1
18	GPIO[50]	GPIO[50]	1
17	GPIO[49]	GPIO[49]	1
16	GPIO[48]	GPIO[48]	1
15	GPIO[47]	GPIO[47]	1
14	GPIO[46]	GPIO[46]	1
13	GPIO[45]	GPIO[45]	1
12	GPIO[44]	GPIO[44]	1
11	GPIO[43]	GPIO[43]	1
10	GPIO[42]	GPIO[42]	1
9	High speed UART nDCD1(HUARTnDCD1)/GPIO[41]	HUARTnDCD1	0
8	High speed UART nCTS1(HUARTnCTS1)/GPIO[40]	HUARTnCTS1	0
7	High speed UART nRTS1(HUARTnRTS1)/GPIO[39]	HUARTnRTS1	0
6	High speed UART nDSR1(HUARTnDSR1)/GPIO[38]	HUARTnDSR1	0
5	High speed UART nDTR1(HUARTnDTR1)/GPIO[37]	HUARTnDTR1	0
4	High speed UART TXD1(HUARTTXD1)/GPIO[36]	HUARTTXD1	0
3	High speed UART RXD1(HUARTRXD1)/GPIO[35]	HUARTRXD1	0
2	GPIO[34]	GPIO[34]	1
1	GPIO[33]	GPIO[33]	1
0	GPIO[32]	GPIO[32]	1

Figure 12-3. I/O Function Control Register 2 (IOPCON2)

12.3.3 I/O PORT CONTROL REGISTER FOR GDMA (IOPGDMA)

If the port is used for a function's port such as an external GDMA Req/Ack signal, its signal function is determined by the IOPGDMA register. IOPGDMA register is used to configure GDMA Req/Ack signal. I/O ports provide 3-tap filtering, and you can select filtering on or off. External signals can be active high or low, so you must set the active high or low bits for the proper operation.

Table 12-4. IOPGDMA Register

Register	Address	R/W	Description	Reset Value
IOPGDMA	0xF0030010	R/W	I/O port special function register for GDMA	0x00000000

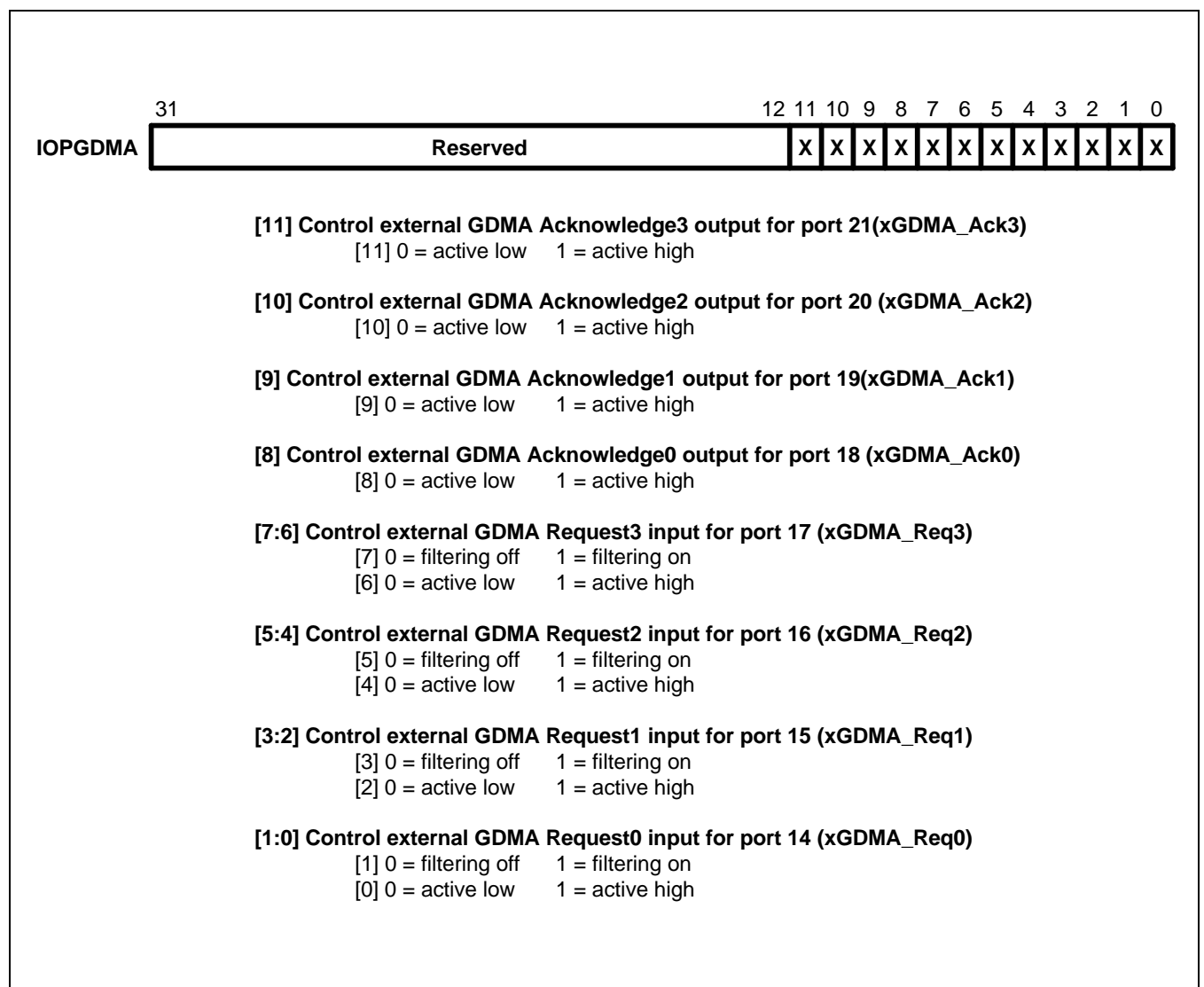

Figure 12-4. I/O Port Control Register for GDMA (IOPGDMA)

12.3.4 I/O PORT CONTROL REGISTER FOR EXTERNAL INTERRUPT (IOPEXTINT)

If the port is used for a function's port such as an external interrupt request, its signal function is determined by the IOPEXTINT register. IOPEXTINT register is used to configure external interrupt request signals. I/O ports provide 3-tap filtering, and you can select filtering on or off. External interrupt provides level or rising or falling edge detection. If you set rising or falling edge detection, rising or falling edge interrupt makes interrupt status high. You can clear the interrupt by writing IOPEXTINTPND register to '1'. If you set level detection, then external interrupt level goes direct to interrupt controller. External signals can be active high or low, so you must set the active high or low bits for the proper operation.

Table 12-5. IOPEXTINT Register

Register	Address	R/W	Description	Reset Value
IOPEXTINT	0xF0030014	R/W	I/O port special function register for external interrupt	0x00000000

12.3.5 I/O PORT EXTERNAL INTERRUPT CLEAR REGISTER (IOPEXTINTPND)

External interrupt clear register (IOPEXTINTPND) is set when external interrupt is generated, and you can clear the interrupt status by writing the IOPEXTINTPND status register to '1'.

Table 12-6. IOPEXTINTPND Register

Register	Address	R/W	Description	Reset Value
IOPEXTINTPND	0xF0030018	R/W	I/O port external interrupt clear register	0x00000000

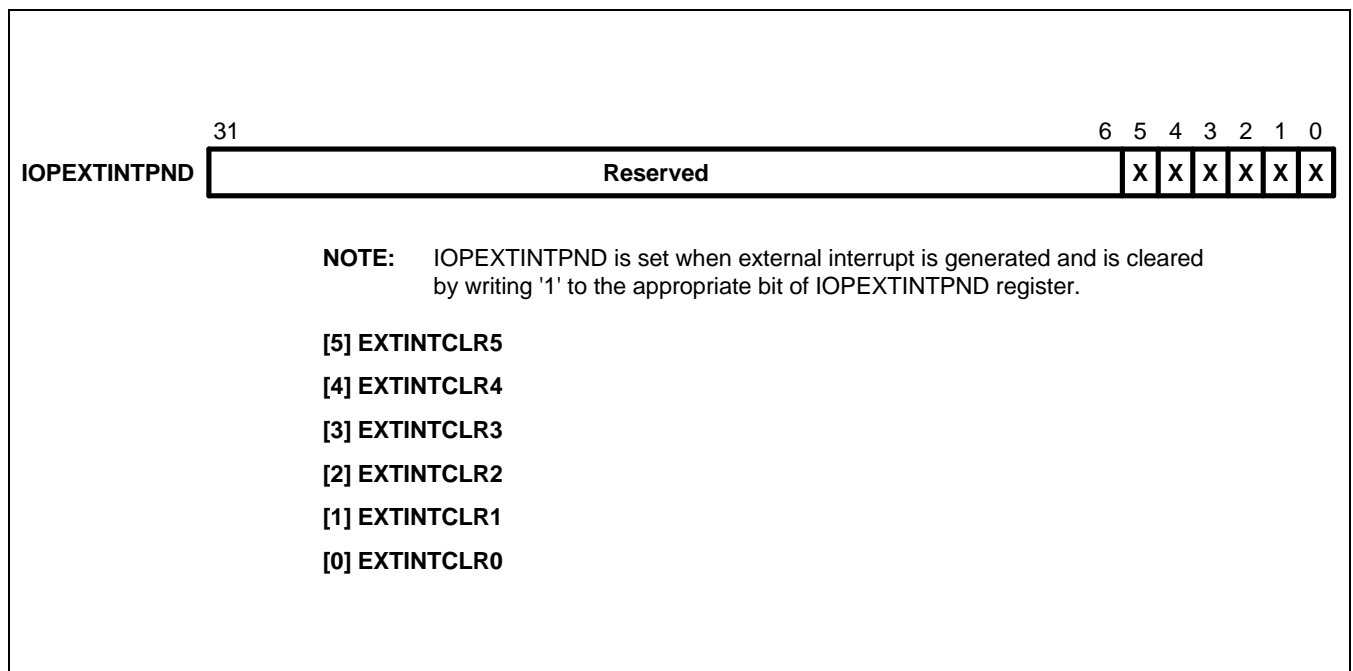

Figure 12-6. I/O Port External Interrupt Clear Register (IOPEXTINTPND)

12.3.6 I/O PORT DATA REGISTER (IOPDATA1/2)

The I/O port data registers, IOPDATA1/2, contain one-bit read values for I/O ports that are configured to input mode and one-bit write values for ports that are configured to output mode.

Table 12-7. IOPDATA1/2 Register

Register	Address	R/W	Description	Reset Value
IOPDATA1	0xF003001C	R/W	I/O port data register for port 0 to 31	Undefined
IOPDATA2	0xF0030020	R/W	I/O port data register for port 32 to 63	Undefined

12.3.7 I/O PORT DRIVE CONTROL REGISTER (IOPDRV1/2)

The I/O port drive control registers, IOPDRV1/2, control the pad type for which is operating as a tri-state output mode or an open-drain output mode. This register's each bit value programmed as write '1' value for open-drain output mode or write '0' value for tri-state output mode.

Table 12-8. IOPDRV1/2 Register

Register	Address	R/W	Description	Reset Value
IOPDRV1	0xF0030024	R/W	I/O port drive control register for port 0 to 31	0x00000000
IOPDRV2	0xF0030028	R/W	I/O port drive control register for port 32 to 63	0x00000000

NOTES

13

INTERRUPT CONTROLLER

13.1 OVERVIEW

The S3C2501X interrupt controller has a total of 29 interrupt sources. Interrupt requests can be generated by internal function blocks or external pins.

The ARM940T core recognizes two kinds of interrupts: a normal interrupt request (IRQ) and a fast interrupt request (FIQ). Therefore all S3C2501X interrupts can be categorized as either IRQ or FIQ. The S3C2501X interrupt controller is level sensitive to each interrupt source.

Three special registers are used to control interrupt generation and handling:

- Interrupt priority registers (INTPRIORn): The index number of each interrupt source is written to the pre-defined interrupt priority register field to obtain that priority. The interrupt priorities are pre-defined from 0x0 to 0x26.
- Interrupt mode register (INTMOD, EXTMOD): Defines the interrupt mode, IRQ or FIQ, for each interrupt source.
- Interrupt mask register (INTMASK, EXTMASK): Indicates that the current interrupt has been disabled if the corresponding mask bit is "1". If an interrupt mask bit is "0" the interrupt will be serviced normally. If the global mask bit (bit 31) of EXTMASK register is set to "1", no interrupt is serviced. When the global mask bit has been set to "0", the interrupt is serviced.

13.2 FEATURES

- Supports IRQ and FIQ Interrupt Request
- Level Sensitive Interrupt Sources
- Supports 23 Internal Interrupt Sources
- Supports 6 External Interrupt Sources
- Supports Interrupt Sources Programmable to Different Priorities
- Supports Global Interrupt Masking

13.3 INTERRUPT SOURCES

The 29 interrupt sources in the S3C2501X interrupt structure are listed, in brief, as follows:

Table 13-1. S3C2501X Internal Interrupt Sources

Index Values	Interrupt Sources
[31]	Watchdog Timer interrupt
[30]	32-bit Timer 5 interrupt
[29]	32-bit Timer 4 interrupt
[28]	32-bit Timer 3 interrupt
[27]	32-bit Timer 2 interrupt
[26]	32-bit Timer 1 interrupt
[25]	32-bit Timer 0 interrupt
[24]	GDMA channel 5 interrupt
[23]	GDMA channel 4 interrupt
[22]	GDMA channel 3 interrupt
[21]	GDMA channel 2 interrupt
[20]	GDMA channel 1 interrupt
[19]	GDMA channel 0 interrupt
[18]	DES interrupt
[17]	Ethernet 1 RX interrupt
[16]	Ethernet 1 TX interrupt
[15]	Ethernet 0 RX interrupt
[14]	Ethernet 0 TX interrupt
[13]	Reserved
[12]	Reserved
[11]	Reserved
[10]	Reserved
[9]	Reserved
[8]	Reserved
[7]	Reserved
[6]	CUART RX interrupt
[5]	CUART TX interrupt
[4]	HUART RX interrupt
[3]	HUART TX interrupt
[2]	Reserved
[1]	Reserved
[0]	IIC interrupt

Table 13-2. S3C2501X External Interrupt Sources

Index Values	Interrupt Sources
[6]	Reserved
[5]	External interrupt 5
[4]	External interrupt 4
[3]	External interrupt 3
[2]	External interrupt 2
[1]	External interrupt 1
[0]	External interrupt 0

13.4 INTERRUPT CONTROLLER SPECIAL REGISTERS

13.4.1 INTERRUPT MODE REGISTERS

Bit settings in the interrupt mode registers, INTMOD and EXTMOD, specify if an interrupt is to be serviced as a fast interrupt (FIQ) or a normal interrupt (IRQ).

Table 13-3. INTMOD, EXTMOD Register

Register	Address	R/W	Description	Reset Value
INTMOD	0xF0140000	R/W	Internal interrupt mode register	0x00000000
EXTMOD	0xF0140004	R/W	External interrupt mode register	0x00000000

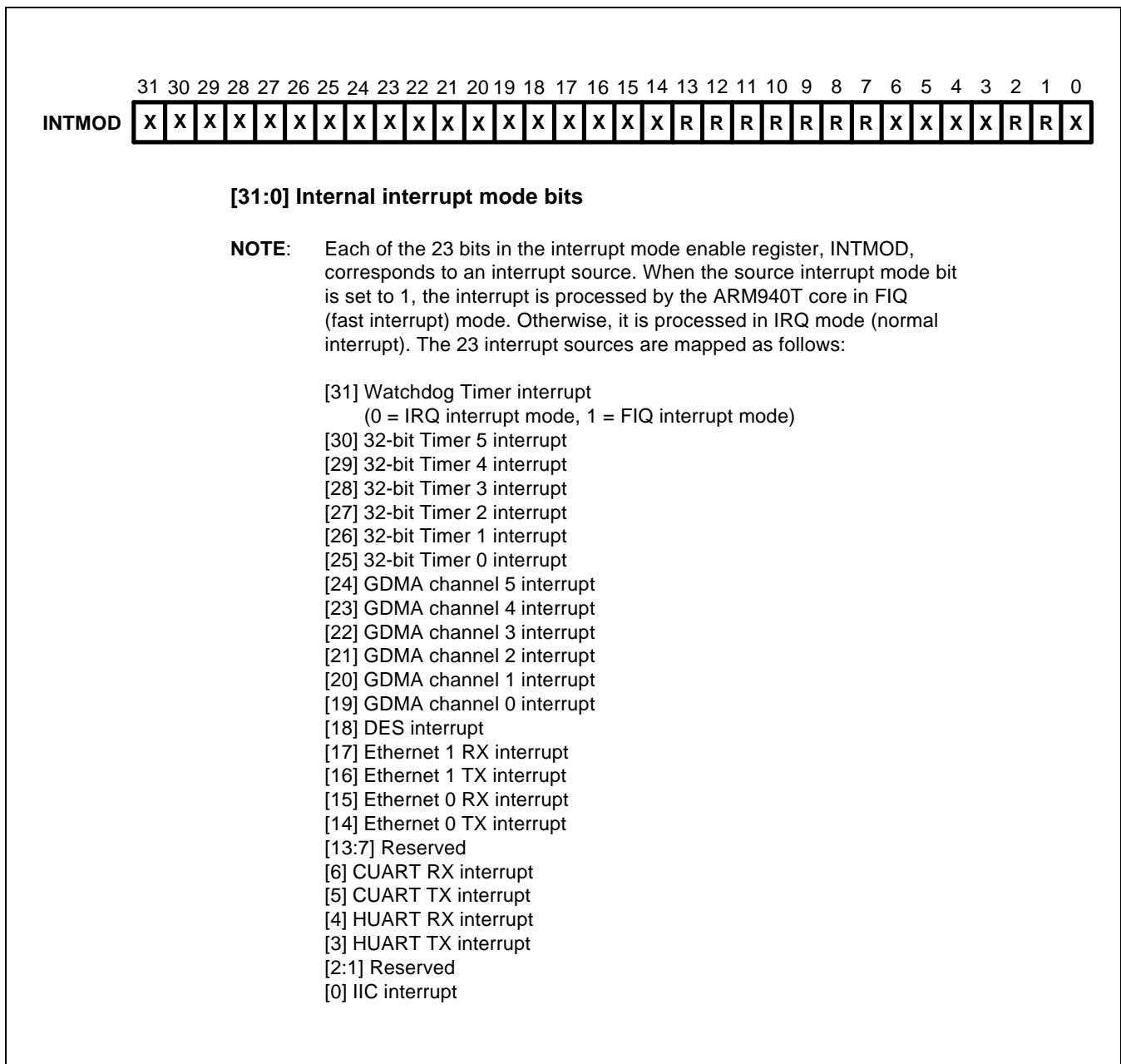

Figure 13-1. Internal Interrupt Mode Register (INTMOD)

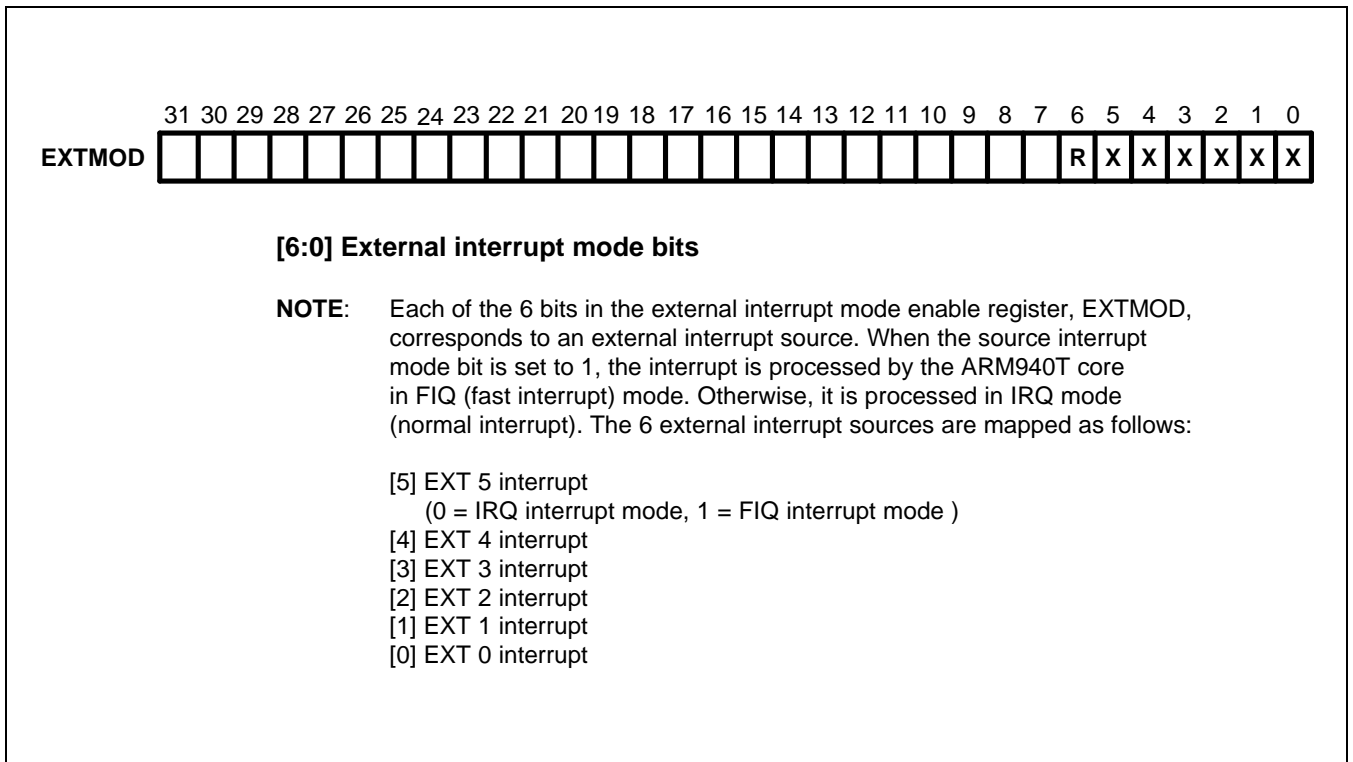

Figure 13-2. External Interrupt Mode Register (EXTMOD)

13.4.2 INTERRUPT MASK REGISTERS

The interrupt mask registers, INTMASK and EXTMASK, contain interrupt mask bits for each interrupt source.

Table 13-4. INTMASK, EXTMASK Register

Register	Address	R/W	Description	Reset Value
INTMASK	0xF0140008	R/W	Internal Interrupt mask register	0xFFFFFFFF
EXTMASK	0xF014000C	R/W	External Interrupt mask register	0x8000007F

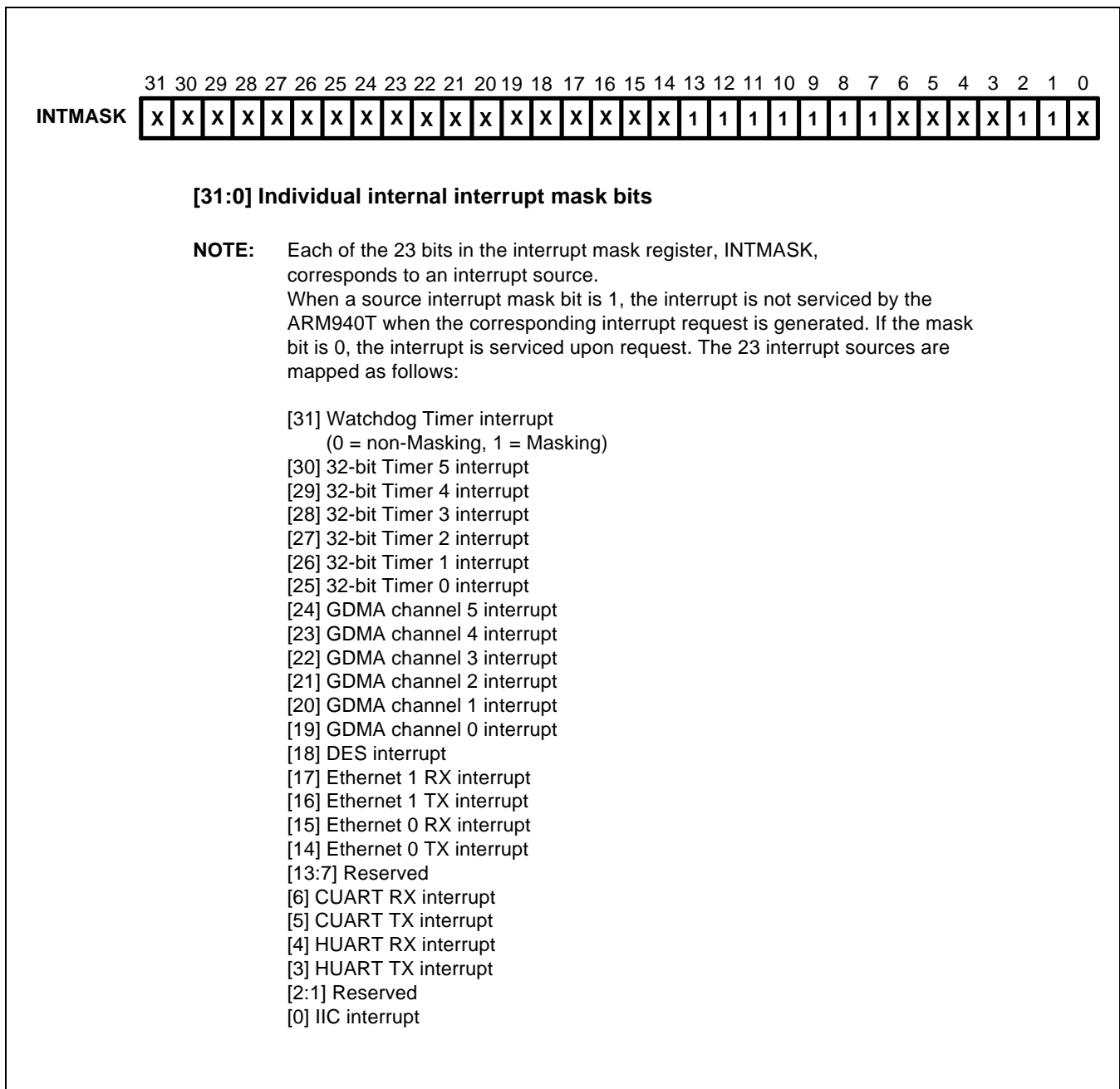

Figure 13-3. Internal Interrupt Mask Register (INTMASK)

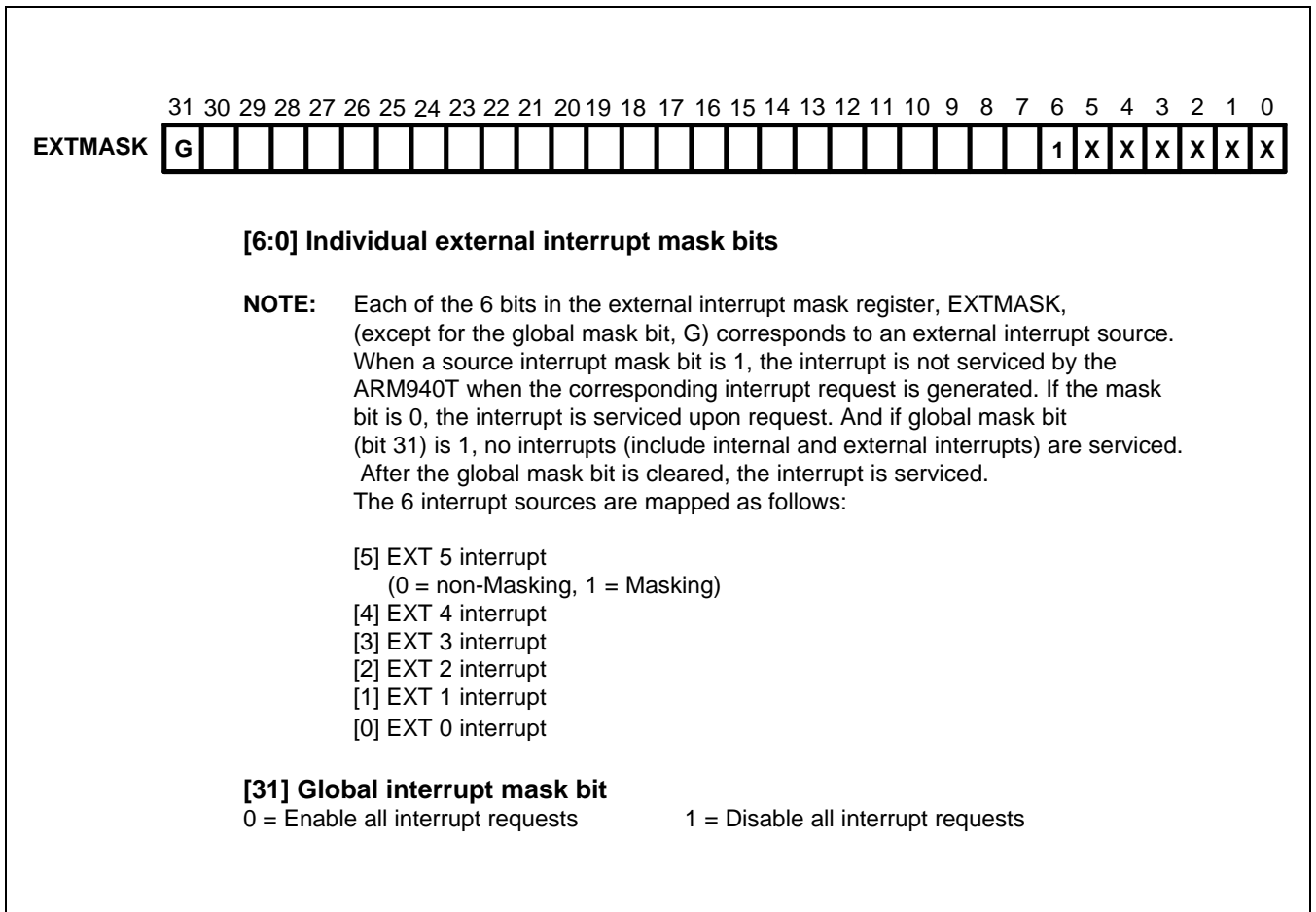

Figure 13-4. External Interrupt Mask Register (EXTMASK)

13.4.3 INTERRUPT PRIORITY REGISTERS

The interrupt priority registers, INTPRIOR0–INTPRIOR9, contain information about which interrupt source is assigned to the pre-defined interrupt priority field. Each INTPRIORn register value determines the priority of the corresponding interrupt source. The lowest priority value is 0x0, and the highest priority value is 0x26.

The index value of each interrupt source is written to one of the above 39 positions (see Figure 13-5). The position value then becomes the written interrupt's priority value. The index value of each interrupt source is listed in Table 13-7.

NOTE

The priority values in priority registers (INTPRIOR0-9) should not be repeated.

Table 13-5. Interrupt Priority Register

Register	Address	R/W	Description	Reset Value
INTPRIOR0	0xF0140020	R/W	Interrupt priority register 0	0x03020100
INTPRIOR1	0xF0140024	R/W	Interrupt priority register 1	0x07060504
INTPRIOR2	0xF0140028	R/W	Interrupt priority register 2	0x0B0A0908
INTPRIOR3	0xF014002C	R/W	Interrupt priority register 3	0x0F0E0D0C
INTPRIOR4	0xF0140030	R/W	Interrupt priority register 4	0x13121110
INTPRIOR5	0xF0140034	R/W	Interrupt priority register 5	0x17161514
INTPRIOR6	0xF0140038	R/W	Interrupt priority register 6	0x1B1A1918
INTPRIOR7	0xF014003C	R/W	Interrupt priority register 7	0x1F1E1D1C
INTPRIOR8	0xF0140040	R/W	Interrupt priority register 8	0x23222120
INTPRIOR9	0xF0140044	R/W	Interrupt priority register 9	0x00262524

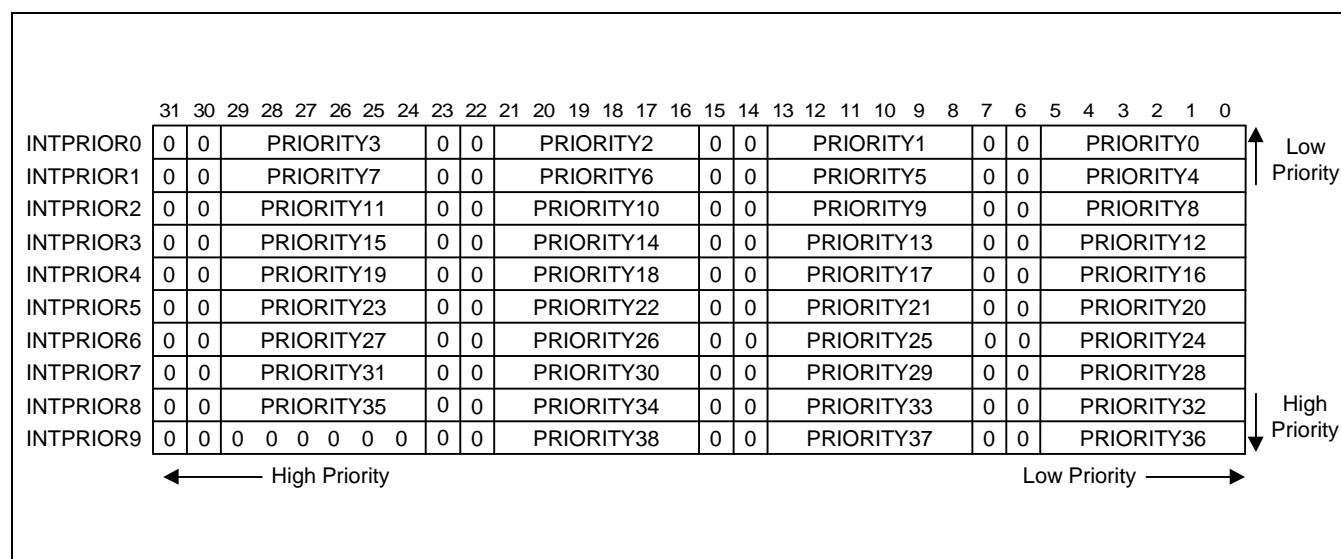

Figure 13-5. Interrupt Priority Register (INTPRIORn)

13.4.4 INTERRUPT OFFSET REGISTER

The interrupt offset registers, INTOFFSET_FIQ and INTOFFSET_IRQ, contain the interrupt offset address of the interrupt, which has the highest priority among the pending interrupts. The content of the interrupt offset address is "index value of the interrupt source".

If all interrupt pending bits are "0" when you read this register, the return value is "0x00000027".

This register is valid only under the IRQ or FIQ mode in the ARM940T. In the interrupt service routine, you should read this register before changing the CPU mode.

NOTE

If the lowest interrupt priority (priority 0) is pending, the INTOFFSET value will be "0x00000000". The reset value will, therefore, be changed to "0x00000027" (to be different from interrupt pending priority 0).

Table 13-6. INTOFFSET_FIQ, INTOFFSET_IRQ Register

Register	Address	R/W	Description	Reset Value
INTOFFSET_FIQ	0xF0140018	R	FIQ interrupt offset register	0x00000027
INTOFFSET_IRQ	0xF014001C	R	IRQ interrupt offset register	0x00000027

Table 13-7. Index Value of Interrupt Sources

Index Value	Type of Interrupt Sources	Returned Default Offset Value (Hex)
[38]	Watchdog Timer interrupt	0 x 26
[37]	32 bit Timer 5 interrupt	0 x 25
[36]	32 bit Timer 4 interrupt	0 x 24
[35]	32 bit Timer 3 interrupt	0 x 23
[34]	32 bit Timer 2 interrupt	0 x 22
[33]	32 bit Timer 1 interrupt	0 x 21
[32]	32 bit Timer 0 interrupt	0 x 20
[31]	GDMA channel 5 interrupt	0 x 1F
[30]	GDMA channel 4 interrupt	0 x 1E
[29]	GDMA channel 3 interrupt	0 x 1D
[28]	GDMA channel 2 interrupt	0 x 1C
[27]	GDMA channel 1 interrupt	0 x 1B
[26]	GDMA channel 0 interrupt	0 x 1A
[25]	DES interrupt	0 x 19
[24]	Ethernet 1 RX interrupt	0 x 18
[23]	Ethernet 1 TX interrupt	0 x 17
[22]	Ethernet 0 RX interrupt	0 x 16
[21]	Ethernet 0 TX interrupt	0 x 15
[20]	Reserved	Reserved
[19]	Reserved	Reserved
[18]	Reserved	Reserved
[17]	Reserved	Reserved
[16]	Reserved	Reserved
[15]	Reserved	Reserved
[14]	Reserved	Reserved
[13]	CUART RX interrupt	0 x D
[12]	CUART TX interrupt	0 x C
[11]	HUART RX interrupt	0 x B
[10]	HUART TX interrupt	0 x A

Table 13-7. Index Value of Interrupt Sources (Continued)

Index Value	Type of Interrupt Sources	Returned Default Offset Value (Hex)
[9]	Reserved	Reserved
[8]	Reserved	Reserved
[7]	IIC interrupt	0 x 7
[6]	Reserved	Reserved
[5]	External interrupt 5	0 x 5
[4]	External interrupt 4	0 x 4
[3]	External interrupt 3	0 x 3
[2]	External interrupt 2	0 x 2
[1]	External interrupt 1	0 x 1
[0]	External interrupt 0	0 x 0

13.4.5 INTERRUPT BY PRIORITY REGISTER

The interrupt by priority registers, IPRIORHI and IPRIORLO, contain interrupt pending bits, which are re-ordered by the INTPRIORn register settings. IPRIORLO[13] is mapped to the interrupt source of whichever bit index is written into the priority 13 field of the INTPRIORn registers.

This register is useful for testing. To validate the interrupt pending by priority value, you can obtain the highest priority pending interrupt from the interrupt offset register, INTOFFSET.

Table 13-8. IPRIORHI, IPRIORLO Register

Register	Address	R/W	Description	Reset Value
IPRIORHI	0xF0140010	R	High bits, 38-32 bit, Interrupt by priority register	0x00000000
IPRIORLO	0xF0140014	R	Low bits, 31-0 bit, Interrupt by priority register	0x00000000

13.4.6 INTERRUPT TEST REGISTER

The interrupt test registers, INTTSTHI and INTTSTLO, are used to monitor a interrupt pending status. The interrupt pending test registers, INTTSTHI and INTTSTLO, are also useful for testing.

Table 13-9. INTTSTHI, INTTSTLO Register

Register	Address	R/W	Description	Reset Value
INTTSTHI	0xF0140048	R	High bits, 38-7 bit, Interrupt test register	0x00000000
INTTSTLO	0xF014004C	R	Low bits, 6-0 bit, Interrupt test register	0x00000000

14

32-BIT TIMERS

14.1 OVERVIEW

The timer has six 32-bit timers and one watchdog timer. Six 32-bit timers have Timer Mode register (TMOD) which is used to control the operation of the six 32-bit timers, Timer Data registers (TDATAN) which are data registers for counting, Timer Count registers (TCNTn) which are count value registers, and Timer Interrupt Clear register (TIC) which is used to clear the current interrupt. These timers can operate in interval mode or in toggle mode. The output signals are TOUTn. The user can enable or disable timers by setting control bits in Timer Mode register (TMOD). An interrupt request is generated whenever a timer count-out (down count) occurs. Watchdog Timer (WDT) has Watchdog Timer register (WDT), which has control bits and data value.

14.2 FEATURE

- 6 Programmable Timers
- Interval Mode or Toggle Mode Operation
- Hardware Watchdog Timer

14.3 INTERVAL MODE OPERATION

In interval mode, a timer generates one-shot pulse of preset timer clock duration whenever a time-out occurs. This pulse generates a time-out interrupt that is directly output at the timer's configured output pin (TOUTn). In this case, the timer frequency monitored at the TOUTn pin is calculated as:

$$f_{\text{TOUT}} = f_{\text{SYSCLK}} / \text{Timer data value, where } f_{\text{SYSCLK}} \text{ is the system bus clock frequency.}$$

14.4 TOGGLE MODE OPERATION

In toggle mode, the timer pulse continues to toggle whenever a time-out occurs. An interrupt request is generated whenever the level of the timer output signal is inverted (that is, when the level toggles). The toggle pulse is output directly at the configured output pin. Using toggle mode, you can achieve a flexible timer clock range with 50% duty. In toggle mode, the timer frequency monitored at the TOUTn pin is calculated as follows:

$$f_{\text{TOUT}} = f_{\text{SYSCLK}} / (2 \times \text{Timer data value})$$

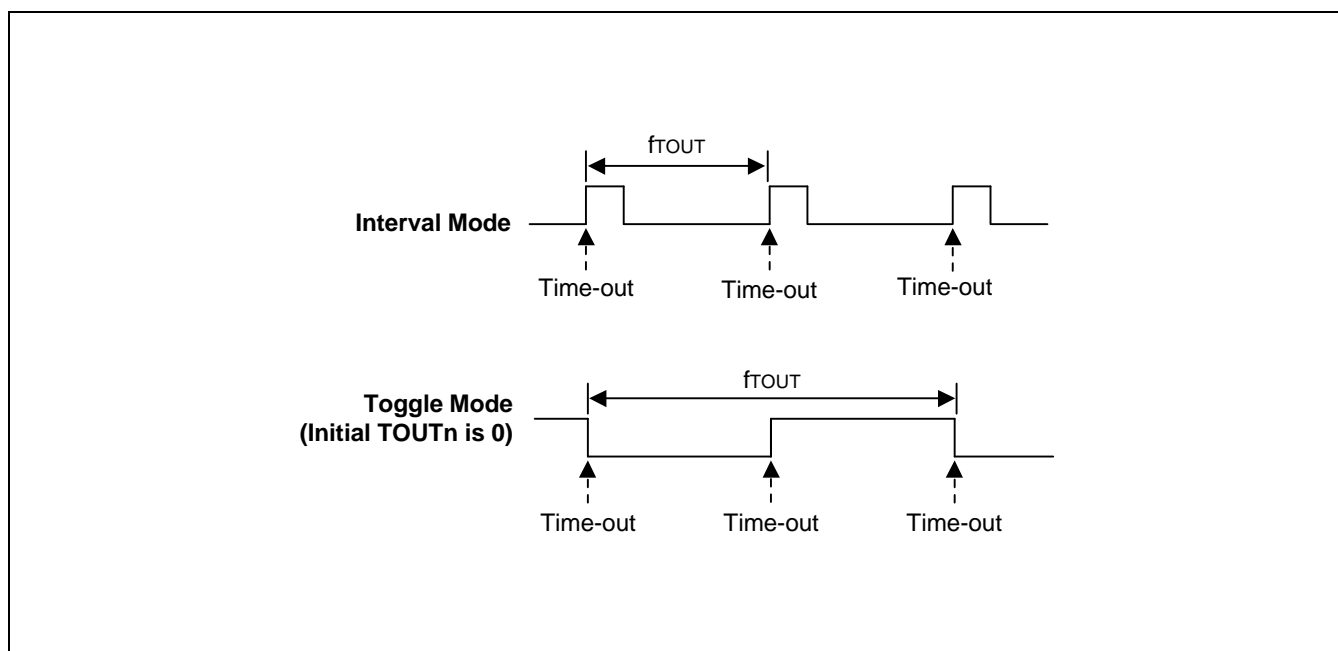

Figure 14-1. Timer Output Signal Timing

14.5 TIMER OPERATION GUIDELINES

The block diagram in Figure 14-2 shows how the 32-bit timers are configured in the S3C2501X. The following guidelines apply to the timer functions.

When a timer is enabled, it loads a data value (TDATA) to its count register (TCNT) and begins decrement of the count register value (TCNT).

When the count register (TCNT) reaches to zero, the associated interrupt is generated. The base value (TDATA) is then reloaded to the count register (TCNT), and the timer continues decrement of its count register value (TCNT).

If a timer is disabled, you can write a new base value into its registers (TDATA).

If the timer is halted while it is running, the base value is not automatically re-loaded.

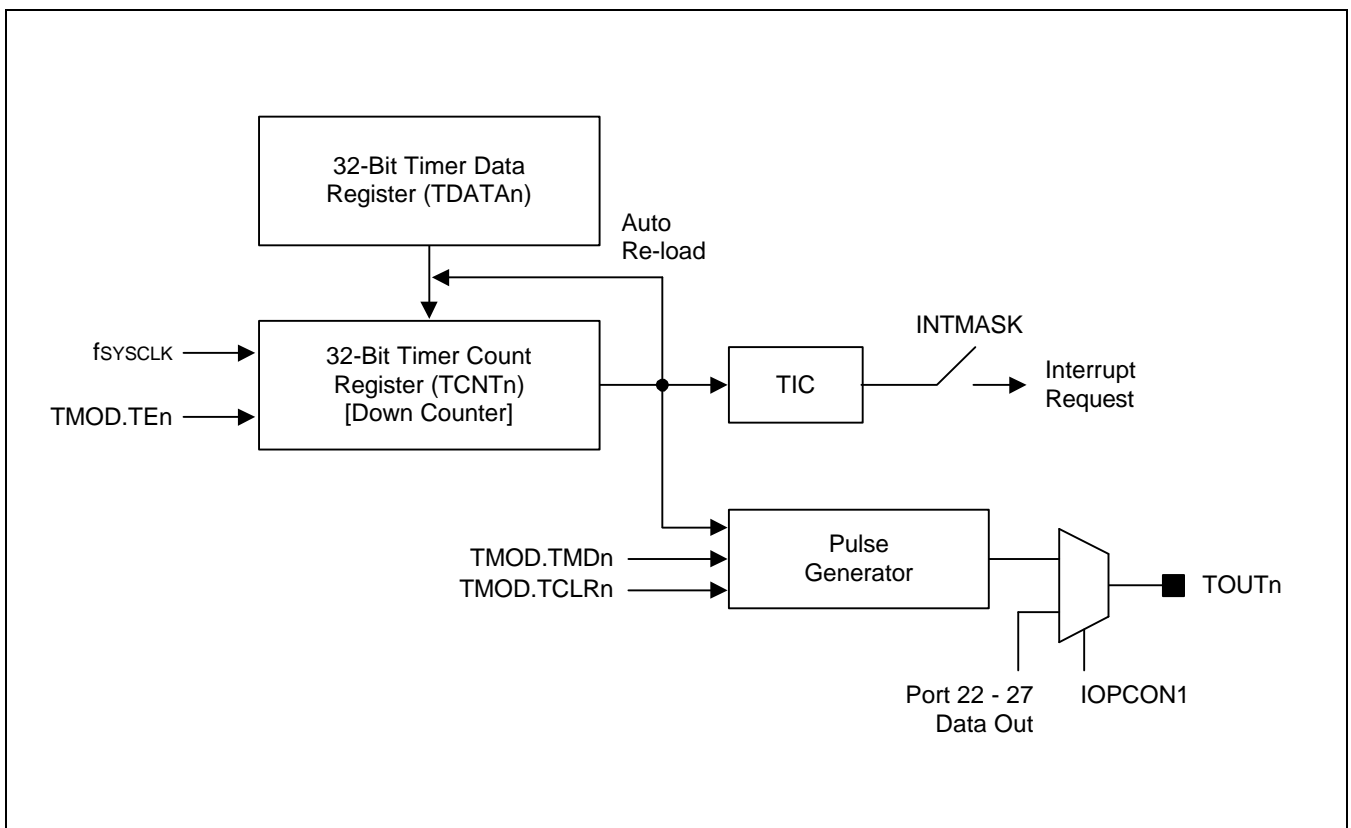

Figure 14-2. 32-Bit Timer Block Diagram

14.6.1 TIMER MODE REGISTER

The timer mode register, TMOD, is used to control the operation of the six 32-bit timers.

Table 14-1. TMOD Register

Register		R/W	Description	
TMOD	0xF0040000		Timer mode register	0x00000000

14.6.2 TIMER DATA REGISTERS

The timer data registers, TDATA0 - TDATA5, contain a value that specifies the time-out duration for each timer. The formula for calculating the time-out duration is: (Timer data) cycles.

The timer is dependent on the system bus clock. When the system bus is 133 MHz, the minimum value, 0x1 for TDATA, generates interrupt at every 7.5n sec. It takes about 32.2 sec for TDATA to go from 0x0 to 0xFFFFFFFF.

Although TOUT signal is designed to come out whenever time-out occurs, it is possible for TOUT signal not to work properly for some TDATA values when interrupt is enabled. The reason is that ARM940T spends the specific time to reach interrupt service routine after time-out takes place. The elapsed time from time-out to interrupt service routine is approximately 27 cycles (200n sec, at 133 MHz). Therefore, TDATA should be set to the bigger value than '0x1A', to avoid another time-out, while it is carrying out the process between time-out and interrupt routine.

Table 14-2. TDATA0 - TDATA5 Registers

Register	Address	R/W	Description	Reset Value
TDATA0	0xF0040010	R/W	Timer 0 data register	0x00000000
TDATA1	0xF0040018	R/W	Timer 1 data register	0x00000000
TDATA2	0xF0040020	R/W	Timer 2 data register	0x00000000
TDATA3	0xF0040028	R/W	Timer 3 data register	0x00000000
TDATA4	0xF0040030	R/W	Timer 4 data register	0x00000000
TDATA5	0xF0040038	R/W	Timer 5 data register	0x00000000

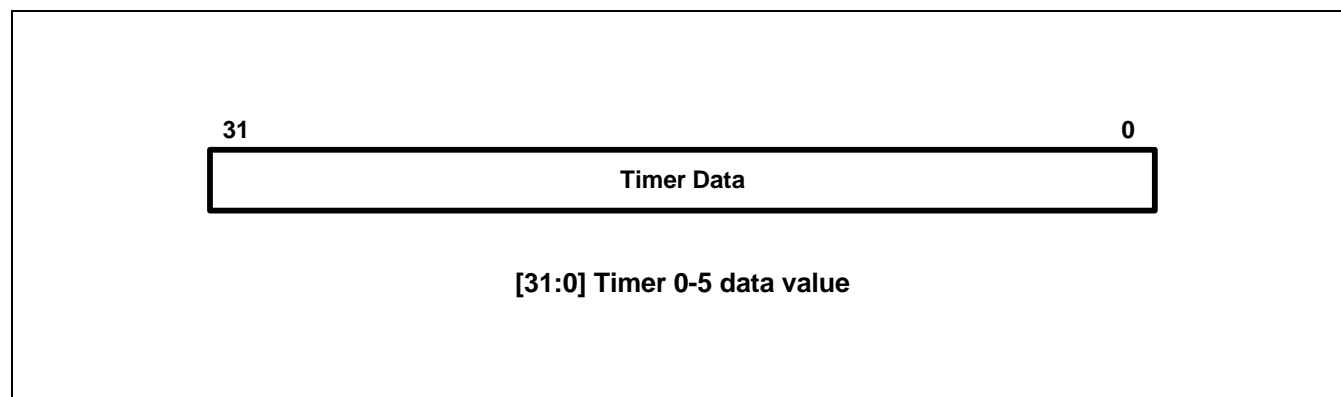

Figure 14-4. Timer Data Registers (TDATA0 - TDATA5)

The timer count registers, TCNT0 - TCNT5, contain the current timer 0 - 5 count value, respectively, during the normal operation.

Register	Address		Description	Reset Value
	0xF0040014	R/W		0xFFFFFFFF
TCNT1		R/W	Timer 1 count register	
TCNT2	0xF0040024		Timer 2 count register	0xFFFFFFFF
	0xF004002C	R/W		0xFFFFFFFF
TCNT4		R/W	Timer 4 count register	
TCNT5	0xF004003C		Timer 5 count register	0xFFFFFFFF

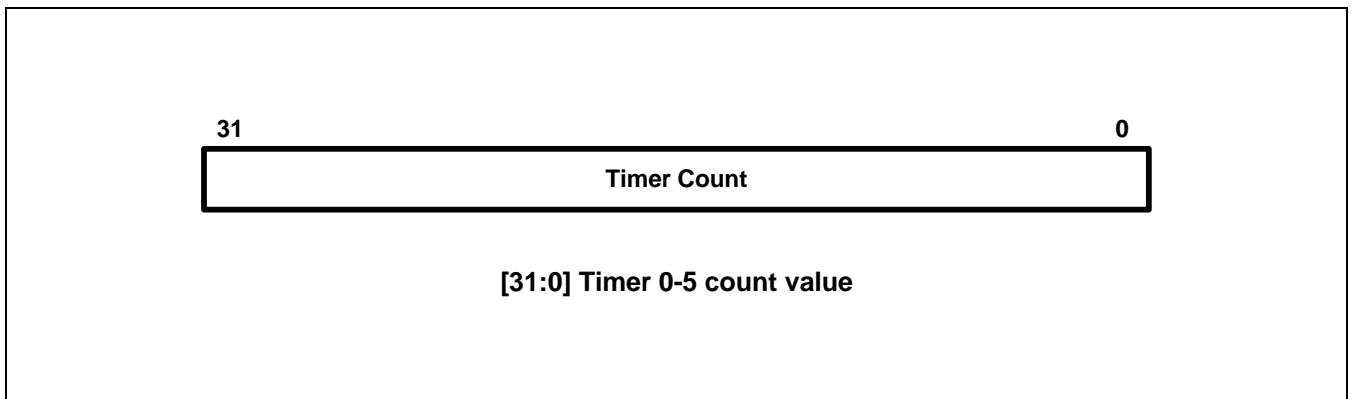

Figure 14-5. Timer Count Registers (TCNT0 - TCNT5)

14.6.4 TIMER INTERRUPT CLEAR REGISTERS

Timer Interrupt Clear register (TIC) clears the current interrupt of the six 32-bit timers and one watchdog timer.

Table 14-4. Timer Interrupt Clear Registers

Register	Address	R/W	Description	Reset Value
TIC	0xF0040004	R/W	Timer Interrupt Clear	0x00000000

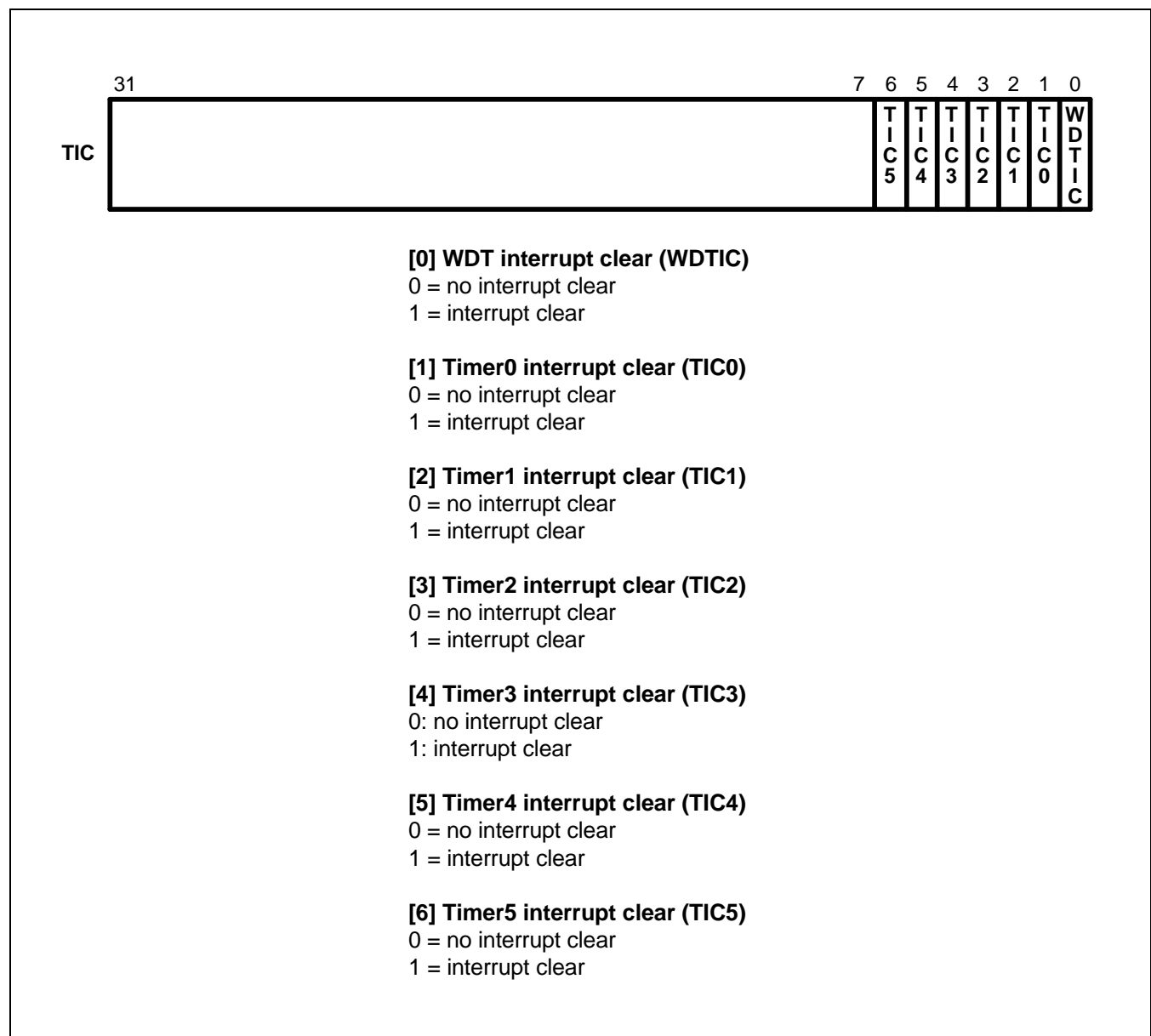

Figure 14-6. Timer Interrupt Clear Register

14.6.5 WATCHDOG TIMER REGISTER (WDT)

To use Watchdog Timer, Watchdog Timer Register (WDT) must be set. If WDT[29] (RST) is '1' when WDT[31] (EN) was asserted, the timeout counter in watchdog timer is cleared as '0'. Following this cycle, WDT[29] (RST) is automatically deasserted. Watchdog Timer Timeout Value (WDTVVAL) can be set as shown in Table 14-6. If the user set two or more bits of WDTVVAL, the lowest significant bit of those let the watch dog timer time out.

Table 14-5. WDT Register

Register	Address	R/W	Description	Reset Value
WDT	0xF0040008	R/W	Watchdog Timer Register	0x00000000

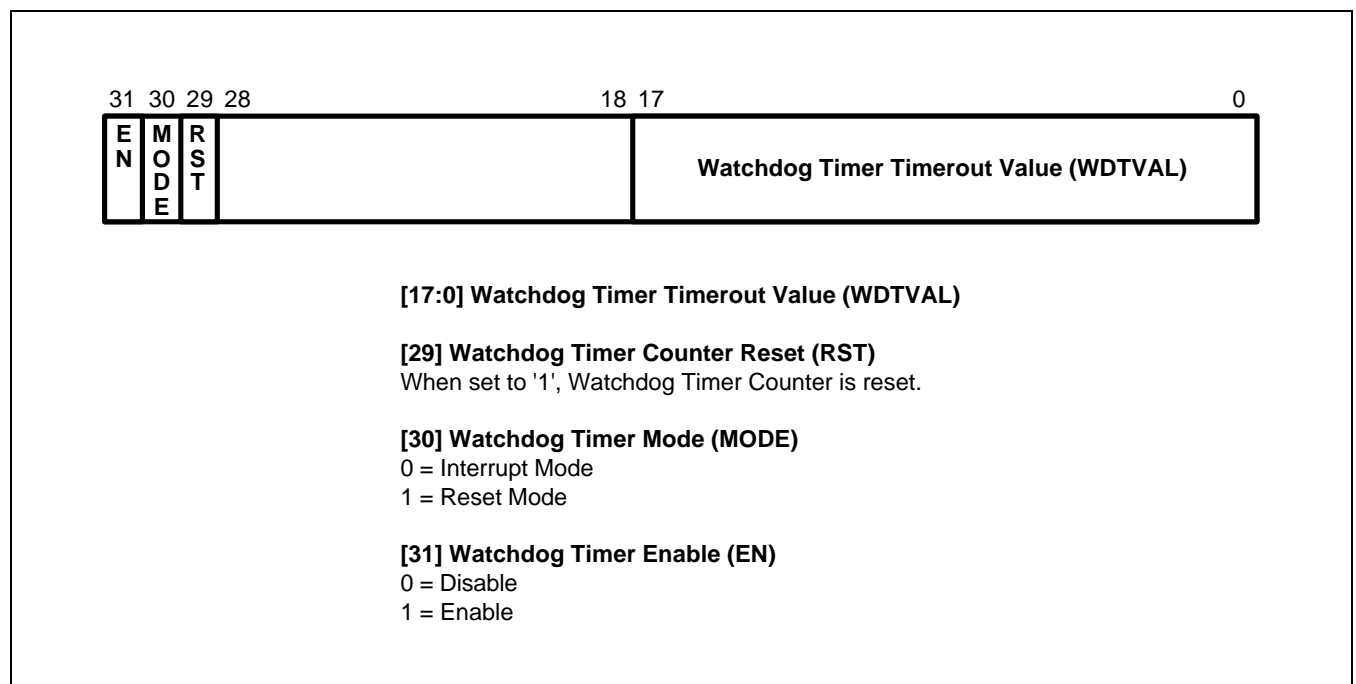

Figure 14-7. Watchdog Timer Register (WDT)

Table 14-6. Watchdog Timer Timeout Value (WDTVVAL, X: Don't Care)

(When watchdog timer operates at 133 MHz)

	16	15		13	12		10	9		7	6		4	3		1	0	
0	0		0	0		0	0		0	0		0	0		0	0		No Operation
X		X	X		X	X		X	X		X	X		X	X		1	2 (3.8us)
X		X	X		X	X		X	X		X	X		X	X		0	2 (30.7us)
X		X	X		X	X		X	X		X	X		X	1		0	2 (245.8us)
X		X	X		X	X		X	X		X	X		1	0		0	2 (491.5us)
X		X	X		X	X		X	X		X	X		0	0		0	2 (983.0us)
X		X	X		X	X		X	X		X	1		0	0		0	2 (1.97ms)
X		X	X		X	X		X	X		1	0		0	0		0	2 (3.93ms)
X		X	X		X	X		X	X		0	0		0	0		0	2 (7.86ms)
X		X	X		X	X		X	1		0	0		0	0		0	2 (15.72ms)
X		X	X		X	X		1	0		0	0		0	0		0	2 (31.45ms)
X		X	X		X	X		0	0		0	0		0	0		0	2 (62.91ms)
X		X	X		X	1		0	0		0	0		0	0		0	2 (125.82ms)
X		X	X		1	0		0	0		0	0		0	0		0	2 (251.65ms)
X		X	X		0	0		0	0		0	0		0	0		0	2 (503.31ms)
X		X	1		0	0		0	0		0	0		0	0		0	2 (1.00s)
X		1	0		0	0		0	0		0	0		0	0		0	2 (2.01s)
X		0	0		0	0		0	0		0	0		0	0		0	2 (4.02s)
1		0	0		0	0		0	0		0	0		0	0		0	2 (8.05s)

15

ELECTRICAL DATA

15.1 OVERVIEW

This chapter describes the S3C2501X electrical data.

15.2 ABSOLUTE MAXIMUM RATINGS

Table 15-1. Absolute Maximum Ratings

Symbol	Parameter	Rating		Unit
V_{DD}	DC supply voltage	1.8V V_{DD}	2.7	V
		3.3V V_{DD}	3.8	
V_{IN}	DC input voltage	3.3V input buffer	3.8	V
V_{OUT}	DC output voltage	3.3V input buffer	3.8	
I_{LATCH}	Latch-up current	± 200		mA
T_{STG}	Storage temperature	- 65 to 150		$^{\circ}\text{C}$

15.3 RECOMMENDED OPERATING CONDITIONS

Table 15-2. Recommended Operating Conditions

Symbol	Parameter	Rating		Unit
V_{DD}	DC supply voltage	1.8V Core	$1.8 \pm 5\%$	V
		3.3V I/O	$3.3 \pm 5\%$	
	PLL DC supply voltage	1.8V Core	$1.8 \pm 5\%$	
V_{IN}	DC input voltage	3.3V input buffer	3.0 - 3.6	V
V_{OUT}	DC output voltage	3.3V output buffer	3.0 - 3.6	
T_A	Commercial temperature range		-40 to 85	$^{\circ}\text{C}$

15.4 DC ELECTRICAL SPECIFICATIONS

 V_{DD} $T_A = -40 \text{ to } 85 \text{ }^\circ\text{C}$

Symbol	Condition	Min	Max	Unit	
I _H	High level input voltage				
	LVC MOS interface	2.0	–		
V	Low level input voltage				
		–	–	V	
VT	Switching threshold		1.4	V	
+	Schmitt trigger, positive-going	CMOS	–	2.0	V
–	Schmitt trigger, negative-	CMOS	0.8	–	V
I _H	High level input current				
	Input buffer	I _{IN} V	–10	–	A
	Input buffer with pull-down			33	
I _L	Low level input current				
	Input buffer	I _{IN} V	–10	–	A
	Input buffer with pull-up		–60	–10	
V	High level output voltage				
		I _{OH} = μA	DD-0.05	–	
	Type B1	I _{OH} = -1	2.4		
	Type B2	I _{OH} = -2			
	Type B4	I _{OH} = -4 mA			
		I _{OH} = -8			
	Type B12	I _{OH} = -12			
	Type B12	I _{OH} = -12			
	Type B16	I _{OH} = -16 mA			
		I _{OH} = -16			
Type B24	I _{OH} = -24				
	I _{OH} = -24				

Table 15-3. D.C Electric Characteristics (Continued)

Symbol	PARAMETER	Condition	Min	Type	Max	Unit	
V_{OL}	Low level output voltage						V
	Type B1 to B12	$I_{OL} = 1 \mu A$	-	-	0.05		
	Type B1	$I_{OL} = 1 mA$			0.4		
	Type B2	$I_{OL} = 2 mA$					
	Type B4	$I_{OL} = 4 mA$					
	Type B8	$I_{OL} = 8 mA$					
	Type B12	$I_{OL} = 12 mA$					
	Type B16	$I_{OL} = 16 mA$					
	Type B20	$I_{OL} = 20 mA$					
Type B24	$I_{OL} = 24 mA$						
I_{OZ}	Tri-state output leakage current	$V_{OUT} = V_{SS}$ or V_{DD}	-10		10	μA	
I_{DS}	Quiescent supply current				100	μA	
I_{DD}	Maximum operating current	$V_{DD} = 3.3 V/1.8 V$ Frequency = 133MHz			(note)	mA	
C_{IN}	Input capacitance	Any Input Bi-directional Buffers			4	pF	
C_{OUT}	Output capacitance	Any Output Buffer			4	pF	

NOTE: Later, It will be updated.

15.5 AC ELECTRICAL CHARACTERISTICS

Table 15-4. Operating Frequency

Characteristic	Min	Max	Units
Core frequency	33	166	MHz
System bus frequency	33	133	MHz
USB Frequency	48	48	MHz

Table 15-5. Clock AC timing specification

Characteristic	Min	Max	Units
Internal PLL lock time	–	150	μs
Frequency of operation (XCLK)	–	133	MHz
XCLK cycle time	7.5	–	ns
XCLK duty cycle	45	55	%
Frequency of operation (HCLKO)	–	133	MHz
HCLKO cycle Time	7.5	–	ns
HCLKO duty cycle	45	55	%

Table 15-6. AC Electrical Characteristics for S3C2501X

Signal Name	Description	Min	Max	Unit
tnRCSd	ROM/SRAM chip select delay time	1.32	3.43	ns
tnRCSH	ROM/SRAM chip select hold time	1.17	3.02	ns
tnOEd	ROM/SRAM output enable delay time	0.79	1.93	ns
tnOEh	ROM/SRAM output enable hold time	0.69	1.7	ns
tnSDWEEd	ROM/SRAM write byte enable delay time	1.23	2.82	ns
tnSDWEh	ROM/SRAM write byte enable hold time	1.42	3.28	ns
tADDRd	ROM/SRAM address delay time	1.02	2.39	ns
tADDRh	ROM/SRAM address hold time	0.94	2.24	ns
tDATAAd	ROM/SRAM data delay time	1.55	3.79	ns
tDATAh	ROM/SRAM data hold time	1.37	3.18	ns
tALEd	ROM/SRAM address latch enable delay time	1.43	3.01	ns
tALEh	ROM/SRAM address latch enable hold time	1.26	3.09	ns
tMADDRd	ROM/SRAM muxed bus address delay time	1.86	4.42	ns
tMADDRh	ROM/SRAM muxed bus address hold time	1.09	2.72	ns
tnWAITd	ROM/SRAM WAIT signal delay time	1	5.11	ns
tnWAITh	ROM/SRAM WAIT signal hold time	1	5.11	ns
tCC	SDRAM Clock Cycle Time	7.5	7.5	ps
tCH	SDRAM Clock High Pulse Width	4.1	4.5	ps
tCL	SDRAM Clock Low Pulse Width	3.4	3.5	ps
tCASd	SDRAM Column Address Strobe Delay Time	2.0	4.7	ps
tCASH	SDRAM Column Address Strobe Hold Time	2.0	4.6	ps
tRASd	SDRAM Row Address Strobe Delay Time	2.0	4.8	ps
tRASH	SDRAM Row Address Strobe Hold Time	2.0	4.7	ps
tCSd	SDRAM Chip Select Delay Time	2.0	4.8	ps
tCSH	SDRAM Chip Select Hold Time	2.0	4.7	ps
tWEEd	SDRAM Write Enable Delay Time	1.7	4.0	ps
tWEh	SDRAM Write Enable Hold Time	1.7	3.9	ps
tWDd	SDRAM Write Data Delay Time	2.3	5.3	ps
tWDh	SDRAM Write Data Hold Time	1.6	3.5	ps
tRDd	SDRAM Read Data Delay Time	6.0	7.0	ps
tRDh	SDRAM Read Data Hold Time	6.0	7.0	ps
tADDRd	SDRAM Address Delay Time	2.2	5.0	ps
tADDRh	SDRAM Address Hold Time	2.2	4.9	ps
tDQMd	SDRAM Data Input/Output Mask Delay Time	2.0	4.9	ps
tDQMh	SDRAM Data Input/Output Mask Hold Time	1.8	4.2	ps

NOTES

16

MECHANICAL DATA

16.1 OVERVIEW

The S3C2501X is available in a 272-pin BGA package (272-BGA-2727-AN).

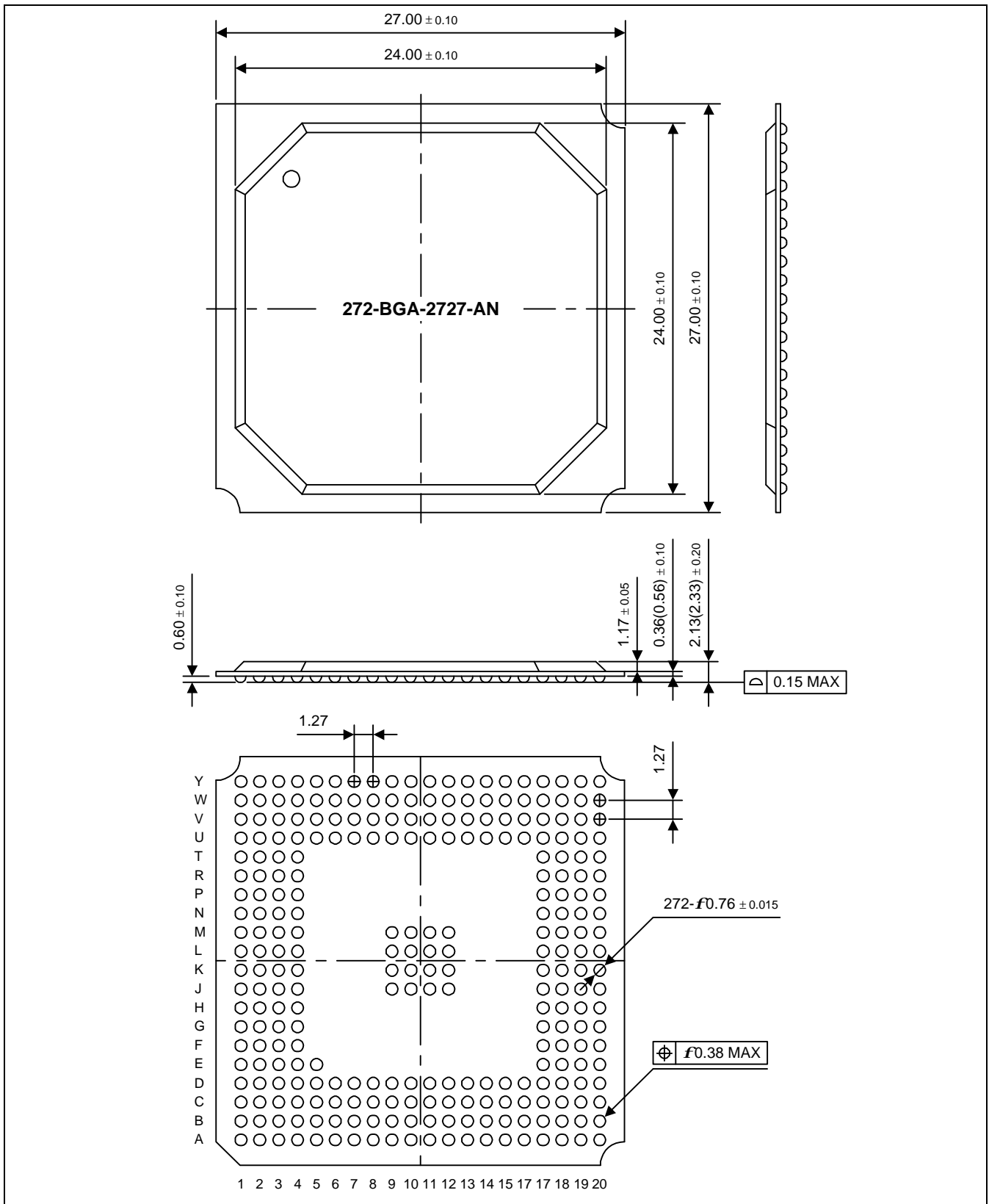

Figure 16-1. 272-BGA-2727-AN Package Dimensions