

1 PRODUCT OVERVIEW

OVERVIEW

Samsung S3C380D 16/32-bit RISC microcontroller is a cost-effective and high-performance microcontroller solution for TV applications.

Among the outstanding features of the S3C380D is its CPU core, a 16/32-bit RISC processor (ARM7TDMI) designed by Advanced RISC Machines, Ltd. The ARM7TDMI core is a low-power, general-purpose microprocessor macro-cell that was developed for use in application-specific and customer-specific integrated circuits. Its simple, elegant, and fully static design is particularly suitable for cost-sensitive and power-sensitive applications.

The S3C380D was developed using the ARM7TDMI core, CMOS standard cell, and a data path compiler. Most of the on-chip function blocks were designed using an HDL synthesizer. The S3C380D has been fully verified in the Samsung ASIC test environment.

By providing a complete set of common system peripherals, the S3C380D minimizes overall system costs and eliminates the need to configure additional components.

The integrated on-chip functions that are described in this document include:

- 4-Kbyte RAM (3008-byte (1504 × 16 bits) general register and 1088-byte (544 × 16 bits) OSD/CCD RAM)
- 128-Kbyte internal program memory
- Two 14-bit PWM modules
- Three 16-bit timers
- On screen display module
- Crystal/Ceramic oscillator or external clock can be used as the clock source
- Standby mode support: SLEEP mode
- One 8-bit basic timer and 3-bit watchdog timer
- Interrupt controller (16 interrupt sources and 2 vectors)
- Five 4-bit ADCs
- Four programmable I/O ports
- 42-pin SDIP

FEATURES

CPU

- ARM7T CPU core

Memory

- 4-Kbyte RAM (3008-byte general purpose register area + 1088-byte OSD/CCD RAM)
- 128 Kbyte internal program memory

General I/O

- Four I/O ports (25 pins total)
(6 V O/D: 3 pins, 5 V O/D: 4 pins)

Basic timer and watchdog timer

- 8-bit counter + 3-bit counter
- Overflow signal of 8-bit counter makes a basic timer interrupt and control the oscillation warm-up time
- Overflow signal of 3-bit counter makes a system reset

Timer/Counters

- Three general purpose 16-bit timer/counters with interval timer modes

Interrupts

- 16 interrupt sources and 2 vectors
- Fast interrupt processing
- 2 interrupt shadow registers (32 bit × 2)

Pulse width modulation (PWM) module

- 14-bit PWM with 2-channel PWM counter

A/D converter

- 5-channel: 4-bit conversion resolution (flash ADC)

Remocon receiver

- FIFO 8 steps
- FIFO interrupt is full (8) step overflow

On screen display (OSD) mode

- Analog level OSD
- Halftone
- 64 character colors
- 16 different character sizes
- Graphic OSD
- S/W CCD

Oscillator frequency

- 32,768 Hz external crystal oscillator
- 1 Hz generation for real time clock
- PLL (Phase Lock Loop) controlled oscillators
- Maximum 16 MHz CPU clock

Operating temperature Range

- -20 °C to +85 °C

Operating Voltage Range

- 4.5 V to 5.5 V

Package Type

- 42-pin SDIP

BLOCK DIAGRAM

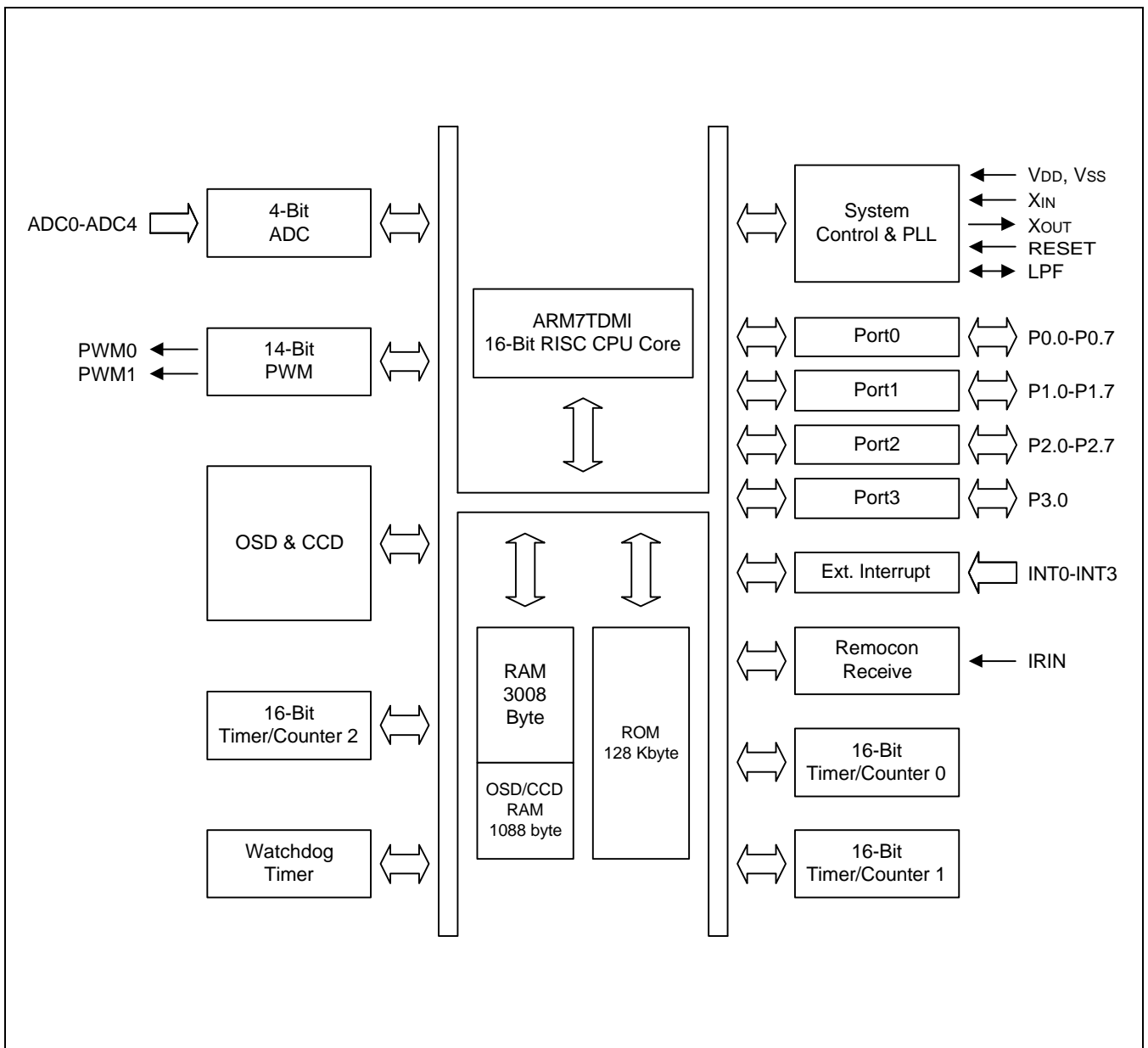

Figure 1-1. S3C380D Block Diagram

PIN ASSIGNMENTS

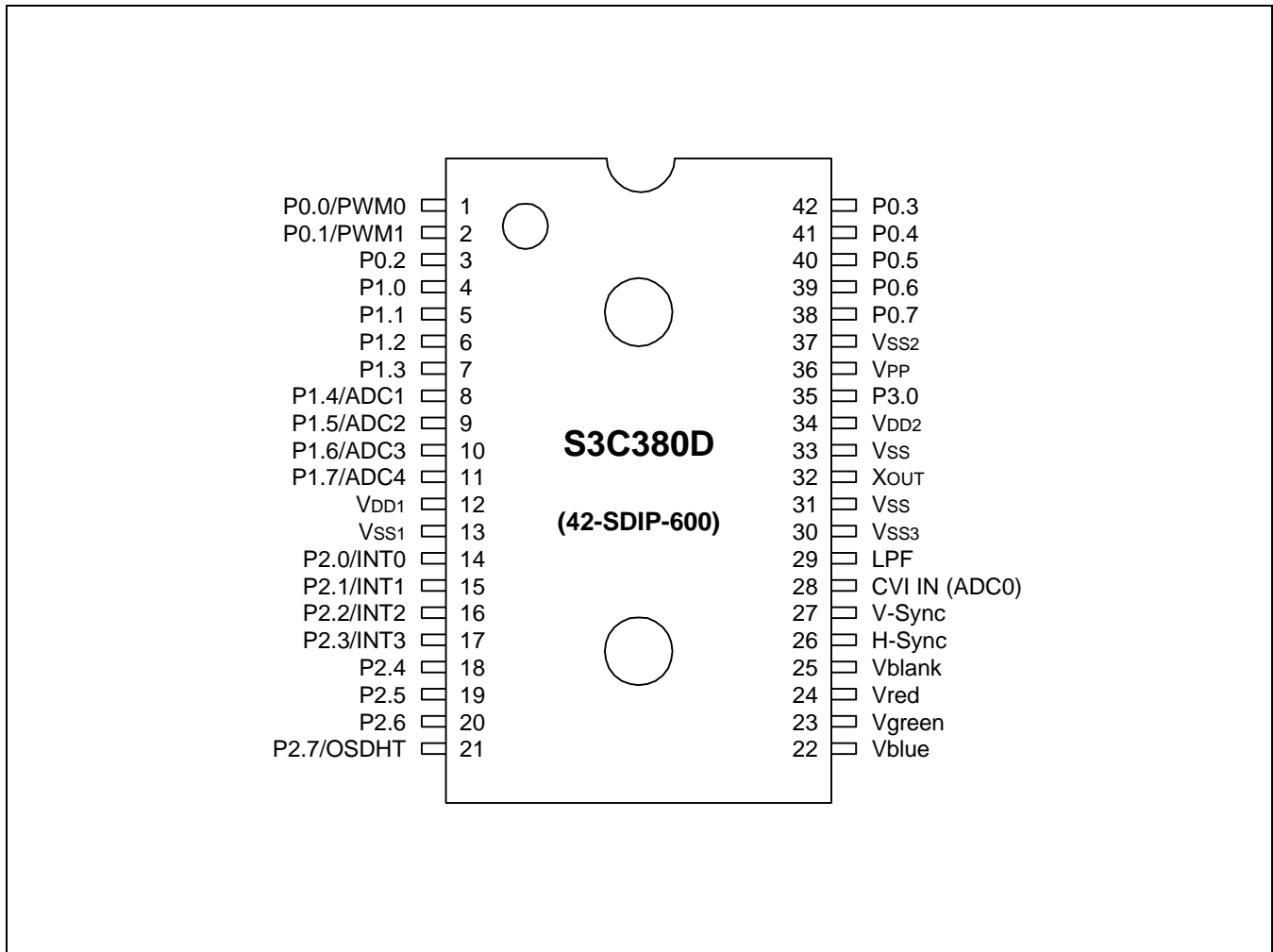

Figure 1-2. S3C380D Pin Assignments (42-SDIP)

PIN DESCRIPTIONS

Table 1-1. S3C380D Pin Descriptions

Pin Name	Pin Type	Pin Description	Circuit Type	Pin Numbers	Share Pins
P0.0	I/O	Input mode or push-pull output mode is software configurable. P0.0: PWM0 (14-bit PWM Output)	6	1	PWM0
P0.1-P0.2 P0.3	I/O	General I/O Port (3-bit), Input or n-channel open-drain output is software configurable. Pins can withstand up to 6-volt loads. An alternative function is supported. P0.1: PWM1 (14-Bit PWM Output)	3	2-3 42	PWM1
P0.4-P0.7		General I/O Port (4-bit), Input or Output mode (push-pull or n-channel open drain) is software configurable.	7	38-41	
P1.0-P1.3	I/O	Input/output mode or push-pull output mode is software configurable.	6	4-7	
P1.4-P1.7	I/O	General I/O Port (4-bit), configurable for digital input or n-channel open drain output. P1.4-P1.7 can withstand up to 5-volt loads. Multiplexed for alternative use as external inputs ADC1-ADC4.	4	8-11	ADC1- ADC4
P2.0-P2.3		General I/O Port (4-bit), input or push-pull output mode is software configurable. Multiplexed for alternative use as external interrupt inputs INT0-INT3.	2	14-17	INT0-INT3
P2.4-P2.7	I/O	Input mode or push-pull output mode is software configurable. An alternative function is supported. P2.7: OSDHT (Halftone signal output)	6	18-21	OSDHT
P3.0	I/O	Input mode or push-pull output mode is software configurable.	6	35	
PWM0	O	Output pin for 14-bit PWM0 circuit	6	1	P0.0
PWM1	O	Output pin for 14-bit PWM1 circuit	3	2	P0.1
ADC1-4	I	Input for 4-bit resolution flash A/D Converter	4	8-11	P1.4-7
INT0-INT3	I	External interrupt input pins	2	14-17	P2.0-3
OSDHT	O	Halftone control signal output for OSD	6	21	P2.7
IRIN	I	Remocon signal input Normal mode: Remocon signal input OTP Write mode: $V_{PP}=12.5\text{ V}$	1	36	–
CVI IN	I	Video signal input	8	28	ADC0

Table 1-1. S3C380D Pin Descriptions (Continued)

Pin Name	Pin Type	Pin Description	Circuit Type	Pin Numbers	Share Pins
RESET	I	System reset input pin	9	33	–
LPF	–	PLL filter pin	–	29	–
H-SYNC	I	H-sync input for OSD and CCD	1	26	–
V-SYNC	I	V-sync input for OSD and CCD	1	27	–
V _{blank}	O	Video blank signal output for OSD and CCD	5	25	–
V _{red}	O	Red signal output for OSD and CCD	5	24	–
V _{green}	O	Green signal output for OSD and CCD	5	23	–
V _{blue}	O	Blue signal output for OSD and CCD	5	22	–
ADC0	I	Input for 4-bit resolution flash A/D Converter (1.5V-2.0V)	8	28	CVI IN
V _{DD1} , V _{DD2} V _{SS1} , V _{SS2} V _{SS3}	–	Power supply pins	–	12, 34 13, 37 30	–
X _{IN} , X _{OUT}	I, O	System clock pins (32,768 Hz)	–	31,32	–

PIN CIRCUITS

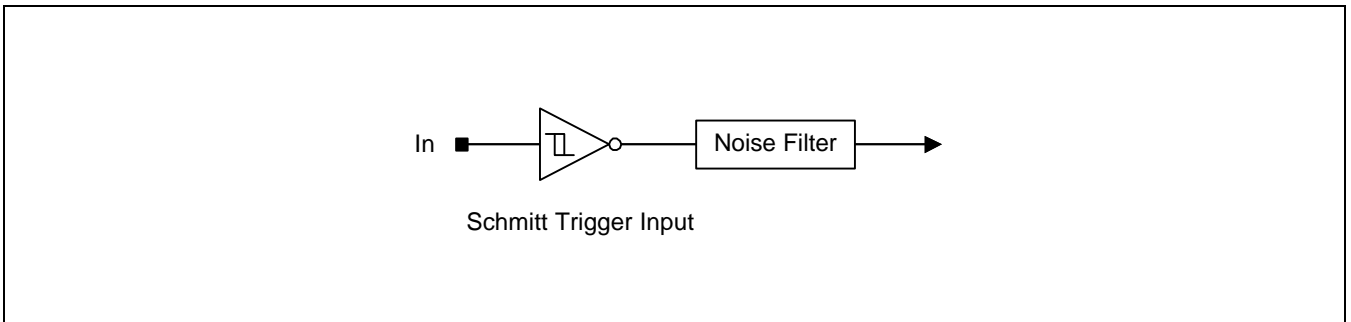

Figure 1-3. Pin Circuit Type 1 (H-Sync, V-Sync, IRIN)

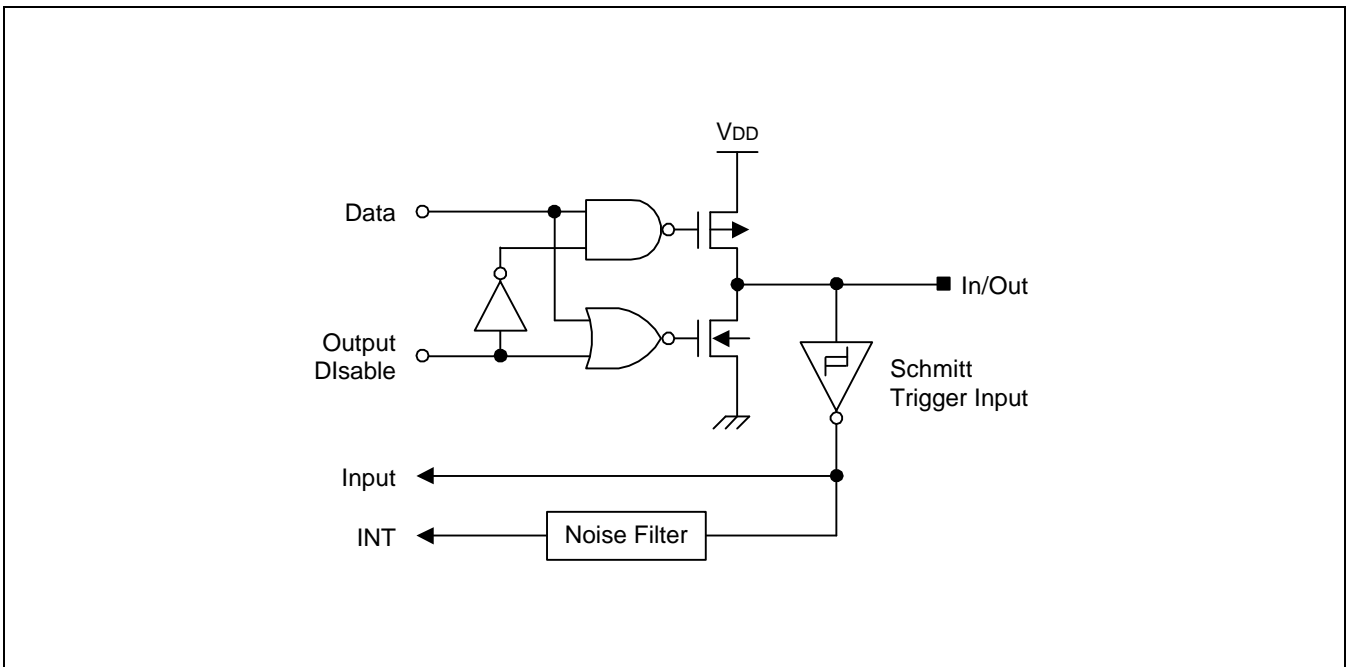

Figure 1-4. Pin Circuit Type 2 (P2.0-P2.3, INT0-INT3)

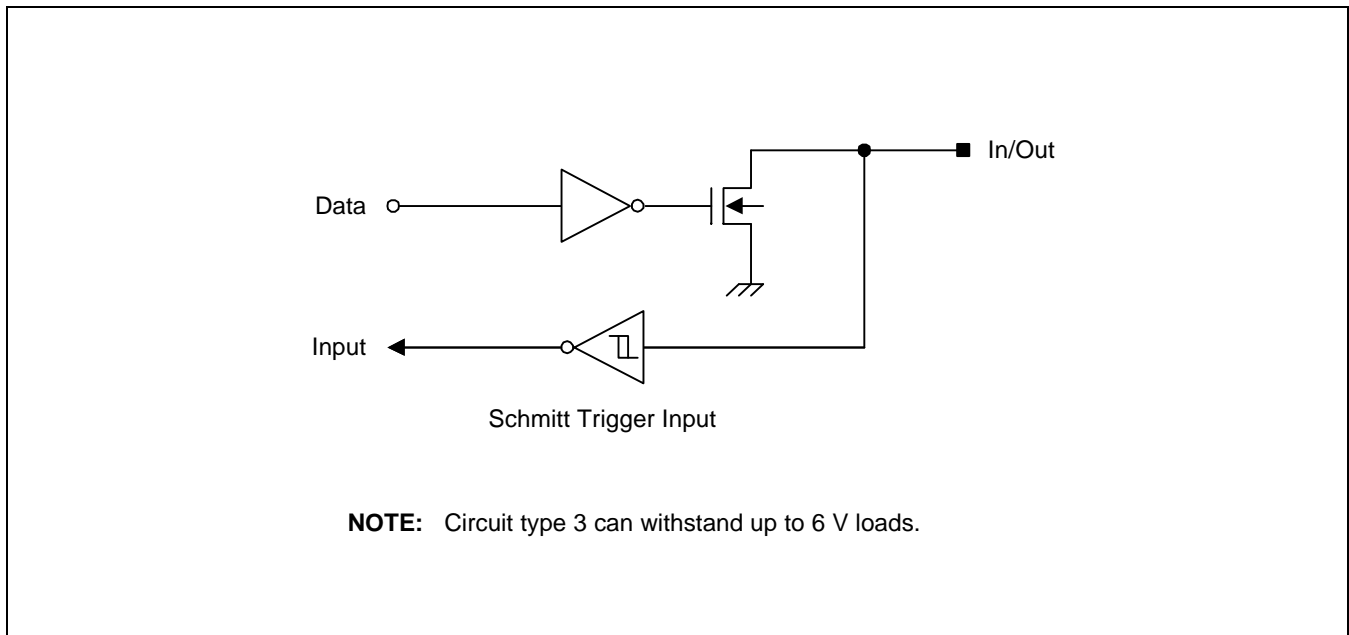

Figure 1-5. Pin Circuit Type 3 (P0.1-P0.3, PWM1)

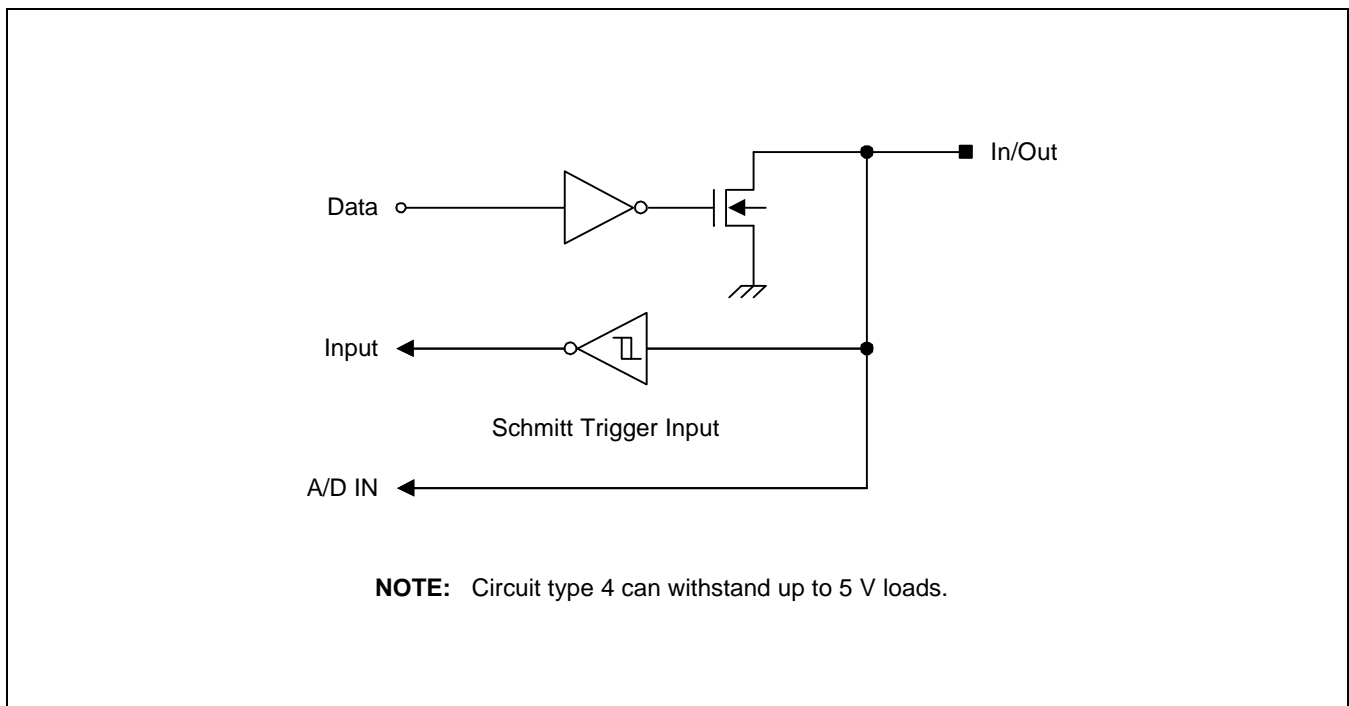

Figure 1-6. Pin Circuit Type 4 (P1.4-P1.7, ADC1-ADC4)

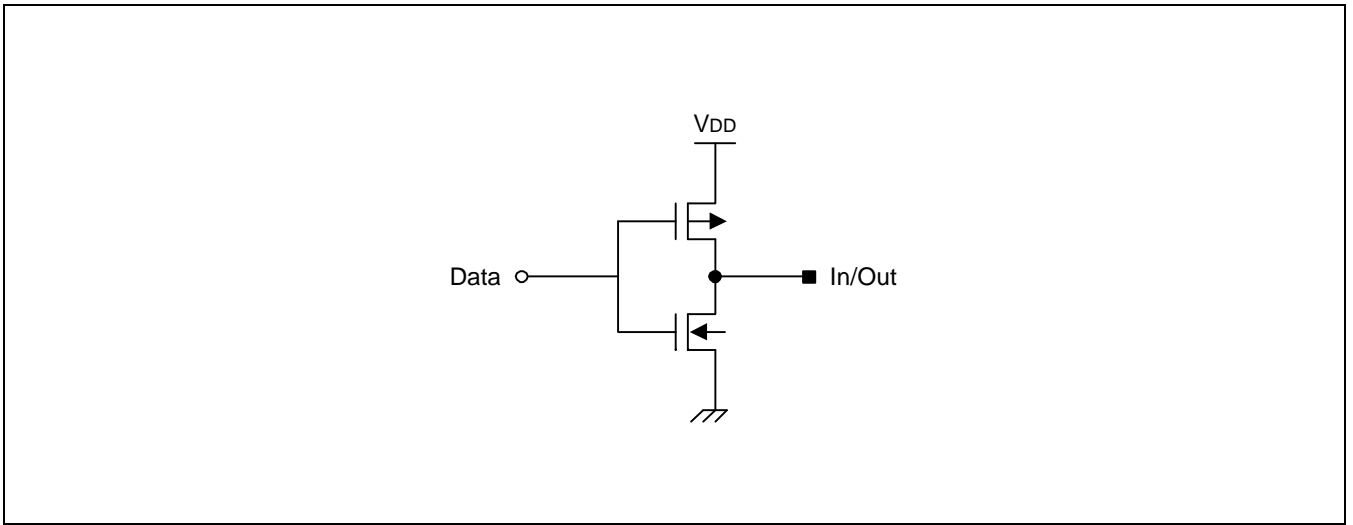

Figure 1-7. Pin Circuit Type 5 (V_{blue} , V_{green} , V_{red} , V_{blank})

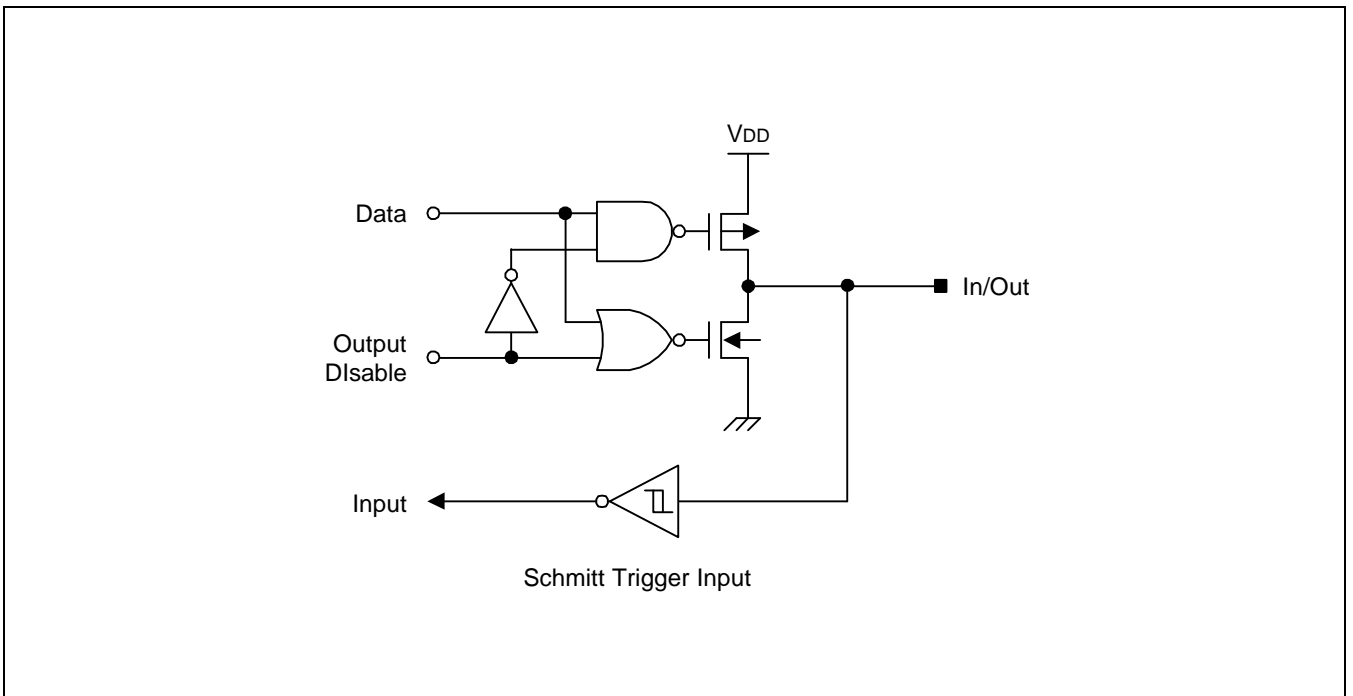

Figure 1-8. Pin Circuit Type 6 (P0.0, P1.0-P1.3, P2.4-P2.7, P3.0, OSDHT, PWM0)

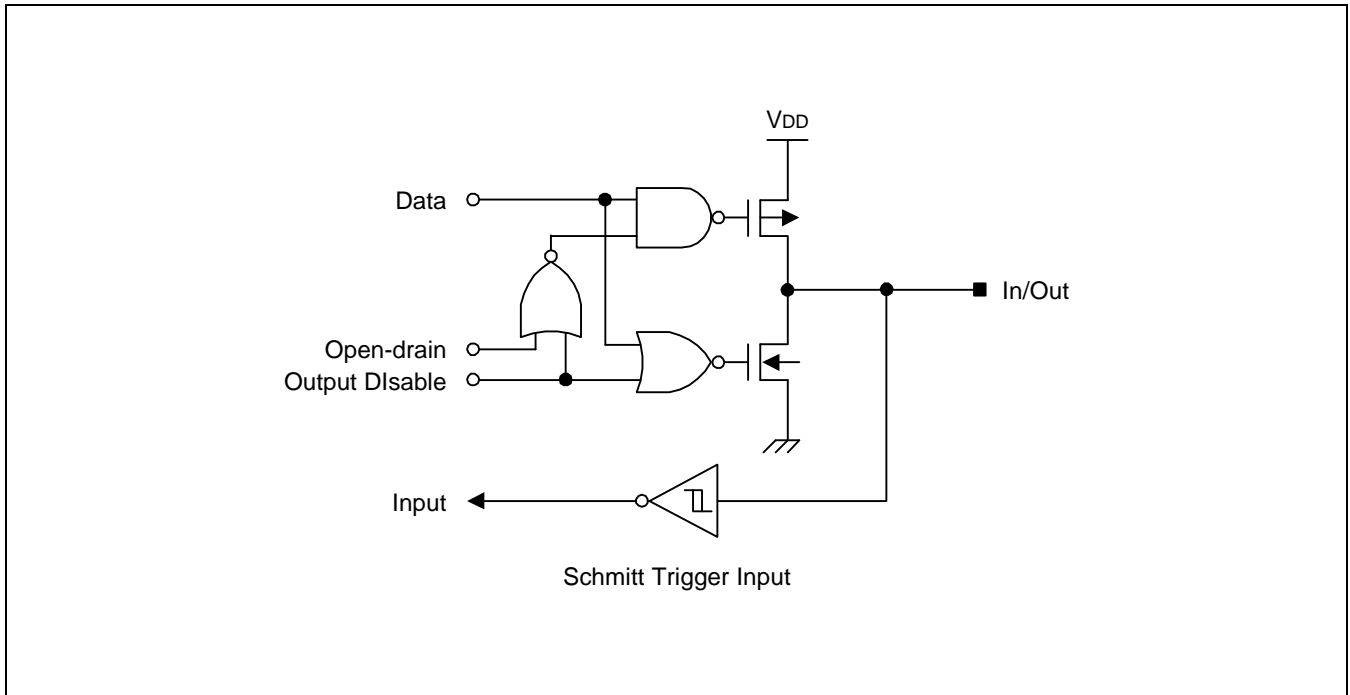

Figure 1-9. Pin Circuit type 7 (P0.4-P0.7)

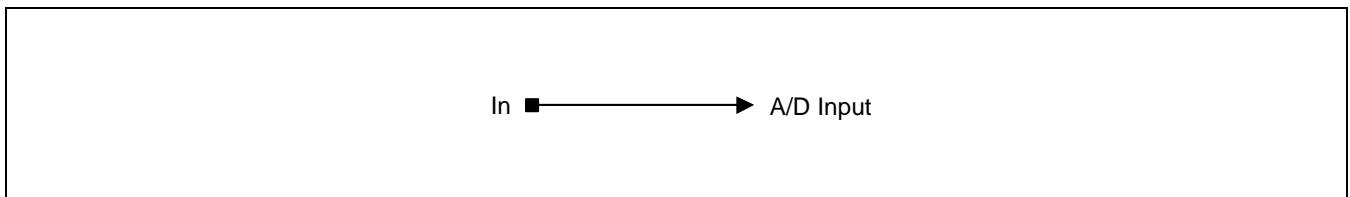

Figure 1-10. Pin Circuit type 8 (CVI IN, ADC0)

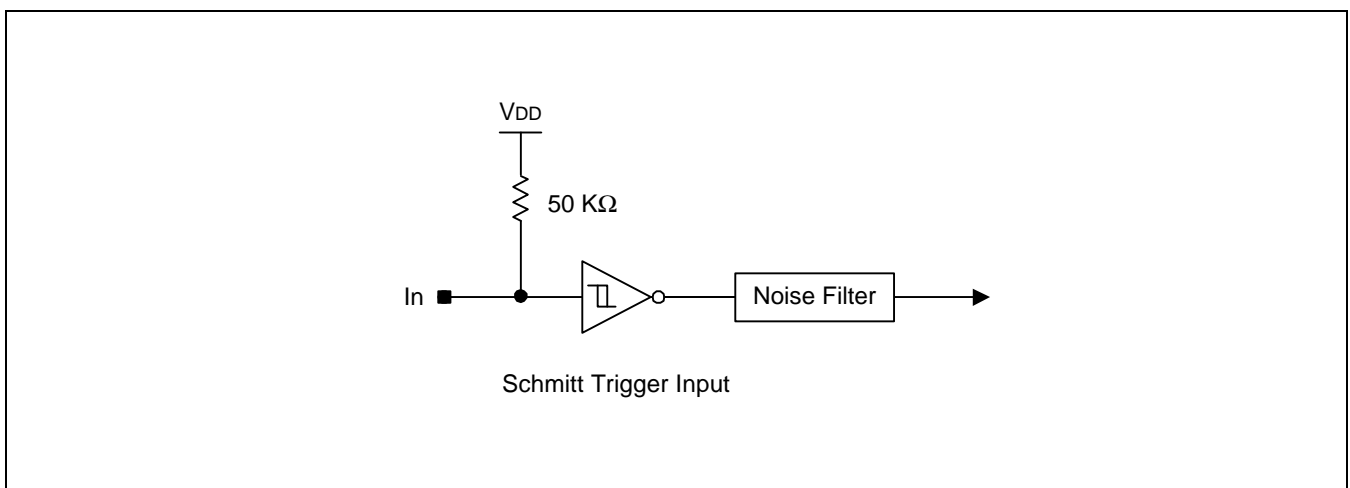

Figure 1-11. Pin Circuit type 9 (RESET)

CPU CORE OVERVIEW

The S3C380D CPU core is the ARM7TDMI processor, a general purpose, 32-bit microprocessor developed by Advanced RISC Machines, Ltd. (ARM). The core's architecture is based on Reduced Instruction Set Computer (RISC) principles. The RISC architecture makes the instruction set and its related decoding mechanisms simpler and more efficient than with microprogrammed Complex Instruction Set Computer (CISC) systems. The resulting benefit is high instruction throughput and impressive real-time interrupt response. Pipelining is also employed so that all components of the processing and memory systems can operate continuously. The ARM7TDMI has a 32-bit address bus.

An important feature of the ARM7TDMI processor, differentiating it from the ARM7 processor, is a unique architectural strategy called *THUMB*. The THUMB strategy is an extension of the basic ARM architecture and consists of 36 instruction formats. These formats are based on the standard 32-bit ARM instruction set, but have been re-coded using 16-bit wide opcodes.

Because THUMB instructions are one-half the bit width of normal ARM instructions, they produce very high-density code. When a THUMB instruction is executed, its 16-bit opcode is decoded by the processor into its equivalent instruction in the standard ARM instruction set. The ARM core then processes the 16-bit instruction as it would a normal 32-bit instruction. In other words, the Thumb architecture gives 16-bit systems a way to access the 32-bit performance of the ARM core without incurring the full overhead of 32-bit processing.

Because the ARM7TDMI core can execute both standard 32-bit ARM instructions and 16-bit Thumb instructions, it lets you mix routines of Thumb instructions and ARM code in the same address space. In this way, you can adjust code size and performance, routine by routine, to find the best programming solution for a specific application.

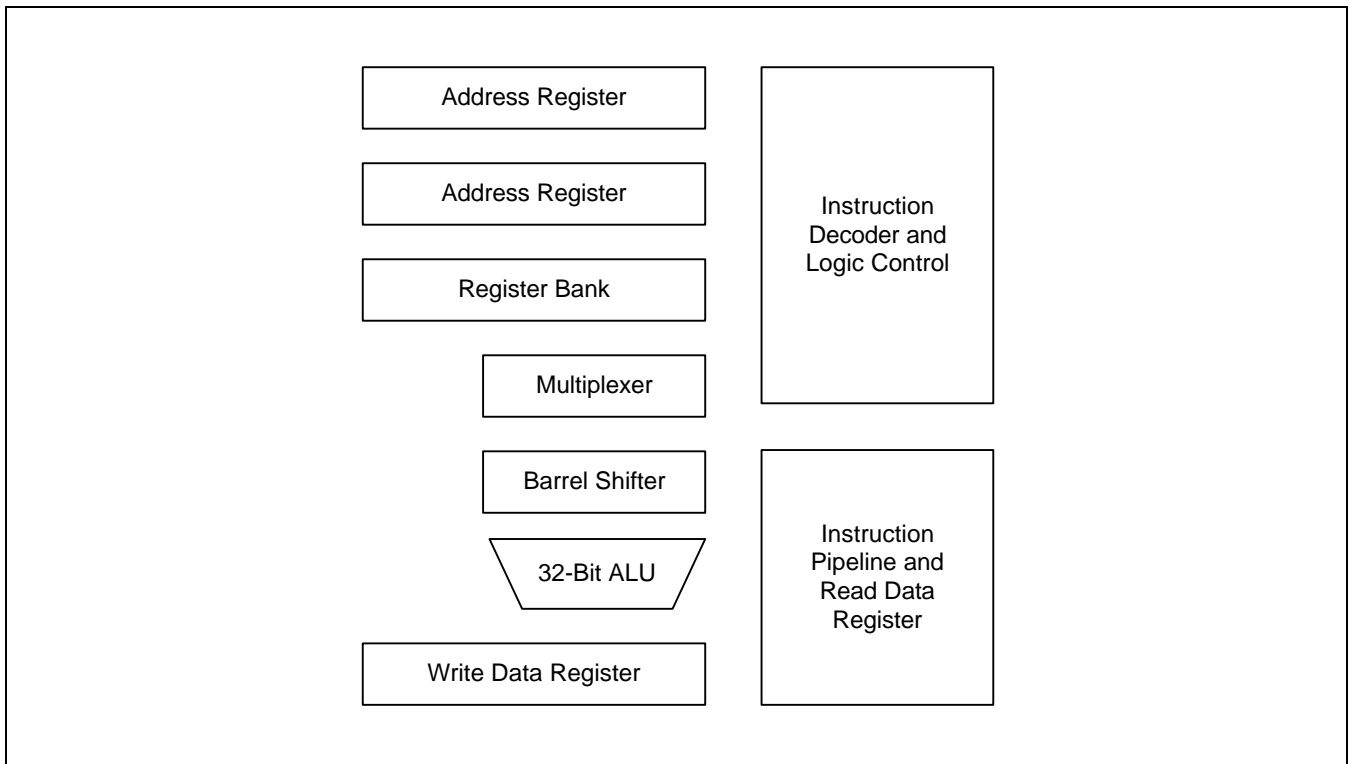

Figure 1-12. ARM7TDMI Core Block Diagram

INSTRUCTION SET

The S3C380D instruction set is divided into two subsets: a standard *32-bit ARM instruction set* and a *16-bit THUMB instruction set*.

The 32-bit ARM instruction set is comprised of thirteen basic instruction types which can, in turn, be divided into four broad classes:

- Four types of branch instructions which control program execution flow, instruction privilege levels, and switching between ARM code and THUMB code.
- Three types of data processing instructions which use the on-chip ALU, barrel shifter, and multiplier to perform high-speed data operations in a bank of 31 registers (all with 32-bit register widths).
- Three types of load and store instructions which control data transfer between memory locations and the registers. One type is optimized for flexible addressing, another for rapid context switching, and the third for swapping data.
- Three types of co-processor instructions which are dedicated to controlling external co-processors. These instructions extend the off-chip functionality of the instruction set in an open and uniform way.

NOTE

All 32-bit ARM instructions can be executed conditionally.

The 16-bit THUMB instruction set contains 36 instruction formats drawn from the standard 32-bit ARM instruction set. The THUMB instructions can be divided into four functional groups:

- Four branch instructions.
- Twelve data processing instructions, which are a subset of the standard ARM data processing instructions.
- Eight load and store register instructions.
- Four load and store multiple instructions.

NOTE

Each 16-bit THUMB instruction has a corresponding 32-bit ARM instruction with the identical processing model.

The 32-bit ARM instruction set and the 16-bit THUMB instruction sets are good targets for compilers of many different high-level languages. When assembly code is required for critical code segments, the ARM programming technique is straightforward, unlike that of some RISC processors which depend on sophisticated compiler technology to manage complicated instruction interdependencies.

Pipelining is employed so that all parts of the processor and memory systems can operate continuously. Typically, while one instruction is being executed, its successor is being decoded, and a third instruction is being fetched from memory.

OPERATING STATES

From a programmer's point of view, the ARM7TDMI core is always in one of two operating states. These states, which can be switched by software or by exception processing, are:

- *ARM state* (when executing 32-bit, word-aligned, ARM instructions), and
- *THUMB state* (when executing 16-bit, half-word aligned THUMB instructions).

OPERATING MODES

The ARM7TDMI core supports seven operating modes:

- *User mode*: the normal program execution state
- *FIQ (Fast Interrupt Request) mode*: for supporting a specific data transfer or channel process
- *IRQ (Interrupt ReQuest) mode*: for general purpose interrupt handling
- *Supervisor mode*: a protected mode for the operating system
- *Abort mode*: entered when a data or instruction pre-fetch is aborted
- *System mode*: a privileged user mode for the operating system
- *Undefined mode*: entered when an undefined instruction is executed

Operating mode changes can be controlled by software, or they can be caused by external interrupts or exception processing. Most application programs execute in User mode. Privileged modes (that is, all modes other than User mode) are entered to service interrupts or exceptions, or to access protected resources.

REGISTERS

The S3C380D CPU core has a total of 37 registers: 31 general-purpose, 32-bit registers, and 6 status registers. Not all of these registers are always available. Which registers are available to the programmer at any given time depends on the current processor operating state and mode.

NOTE

When the S3C380D is operating in ARM state, 16 general registers and one or two status registers can be accessed at any time. In privileged mode, mode-specific banked registers are switched in.

Two register sets, or banks, can also be accessed, depending on the core's current state: the *ARM state register set* and the *THUMB state register set*.

- The ARM state register set contains 16 directly accessible registers: R0-R15. All of these registers, except for R15, are for general-purpose use, and can hold either data or address values. An additional (seventeenth) register, the CPSR (Current Program Status Register), is used to store status information.
- The THUMB state register set is a subset of the ARM state set. You can access eight general registers, R0-R7, as well as the program counter (PC), a stack pointer register (SP), a link register (LR), and the CPSR. Each privileged mode has a corresponding banked stack pointer, link register, and saved process status register (SPSR).

The THUMB state registers are related to the ARM state registers as follows:

- THUMB state R0-R7 registers and ARM state R0-R7 registers are identical
- THUMB state CPSR and SPSRs and ARM state CPSR and SPSRs are identical
- THUMB state SP, LR, and PC map directly to ARM state registers R13, R14, and R15, respectively

In THUMB state, registers R8-R15 are not part of the standard register set. However, you can access them for assembly language programming and use them for fast temporary storage, if necessary.

EXCEPTIONS

An *exception* arises whenever the normal flow of program execution is interrupted. For example, when processing must be diverted to handle an interrupt from a peripheral. The processor's state just prior to handling the exception must be preserved so that the program flow can be resumed when the exception routine is completed. Multiple exceptions may arise simultaneously.

To process exceptions, the S3C380D uses the banked core registers to save the current state. The old PC value and the CPSR contents are copied into the appropriate R14 (LR) and SPSR register. The PC and mode bits in the CPSR are forced to a value which corresponds to the type of exception being processed.

The S3C380D core supports seven types of exceptions. Each exception has a fixed priority and a corresponding privileged processor mode, as shown in Table 1-2.

Table 1-2. S3C380D CPU Exceptions

Exception	Mode on Entry	Priority
Reset	Supervisor mode	1 (Highest)
Data abort	Abort mode	2
FIQ	FIQ mode	3
IRQ	IRQ mode	4
Prefetch abort	Abort mode	5
Undefined instruction	Undefined mode	6 (Lowest)
Software interrupt	Supervisor mode	6 (Lowest)

17

ELECTRICAL DATA

OVERVIEW

This chapter describes the S3C380D electrical data. Information is presented according to the following Table of Contents:

Table 17-1. Absolute Maximum Ratings

($T_A = 25^\circ\text{C}$)

Parameter	Symbol	Conditions	Rating	Unit
Supply voltage	V_{DD}		- 0.3 to + 7.0	V
Input voltage	V_{I1}	P0.1-P0.3, P1.4-P1.7 (open-drain)	- 0.3 to + 6	V
	V_{I2}	All ports except V_{I1}	- 0.3 to $V_{DD} + 0.3$	
Output voltage	V_O	All output ports	- 0.3 to $V_{DD} + 0.3$	V
Output current high	I_{OH}	One I/O pin active	- 10	mA
		All I/O pins active	- 50	
Output current low	I_{OL}	One I/O pin active	+ 20	mA
		Total pin current for ports 0, 1, 2, and 3	+ 100	
Operating temperature	T_A	-	- 20 to + 85	$^\circ\text{C}$
Storage temperature	T_{STG}	-	- 40 to + 125	$^\circ\text{C}$

Table 17-2. D.C. Electrical Characteristics

(T_A = -20°C to +85°C, V_{DD} = 4.5 V to 5.5 V)

Parameter	Symbol	Conditions	Min	Typ	Max	Unit
Input high voltage	V _{IH1}	All input pins except V _{IH2}	0.8 V _{DD}	-	V _{DD}	V
	V _{IH2}	RESET	0.85 V _{DD}			
Input low voltage	V _{IL1}	All input pins except V _{IL2}	-	-	0.2 V _{DD}	V
	V _{IL2}	RESET			0.15 V _{DD}	
Output high voltage	V _{OH1}	V _{blank} , P2.4, P2.5 I _{OH} = -1 mA	V _{DD} - 1.0	-	-	V
	V _{OH2}	All ports except V _{OH1} I _{OH} = -500 uA	V _{DD} - 0.5			
Output low voltage	V _{OL1}	P2.4, P2.5 I _{OL} = 15 mA	-	-	1.0	V
	V _{OL2}	All ports except V _{OL1} , V _{OL3} I _{OL} = 2 mA			0.4	
	V _{OL3}	V _{blank} I _{OL} = 1 mA			0.4	
Input high leakage current	I _{LIH1}	V _{IN} = V _{DD} All input pins except I _{LIH2}	-	-	1	uA
	I _{LIH2}	V _{IN} = V _{DD} X _{IN} , X _{OUT}	3		20	
Input low leakage current	I _{LIL1}	V _{IN} = 0 V All input pins except I _{LIL2}	-	-	-1	uA
	I _{LIL2}	V _{IN} = 0 V X _{IN} , X _{OUT}	-3		-20	
Output high leakage current	I _{LOH1}	V _{OUT} = V _{DD} All output pins except I _{LOH2}	-	-	1	uA
	I _{LOH2}	V _{OUT} = 6 V P0.1-P0.3, P1.4-P1.7 (N-channel, open-drain)			10	
Output low leakage current	I _{LOL}	V _{OUT} = 0 V All output pins	-	-	-1	uA

Table 17-2. D.C. Electrical Characteristics (Continued)

($T_A = -40^{\circ}\text{C}$ to $+85^{\circ}\text{C}$, $V_{DD} = 4.5\text{ V}$ to 5.5 V)

Parameter	Symbol	Conditions	Min	Typ	Max	Unit
Pull-up resistor	R_{P2}	$V_{IN} = 0\text{ V}$ RESET only	30	50	70	$\text{K}\Omega$
Supply current	I_{DD1}	$V_{DD} = 5\text{ V}$ 16 MHz CPU clock	-	50	100	mA
	I_{DD2}	Sleep mode		0.5	1	

Table 17-3. A.C. Electrical Characteristics

($T_A = -40^{\circ}\text{C}$ to $+85^{\circ}\text{C}$, $V_{DD} = 4.5\text{ V}$ to 5.5 V)

Parameter	Symbol	Conditions	Min	Typ	Max	Unit
Interrupt input high, low width	t_{INTH} , t_{INTL}	Ports 2.0-2.3	-	300	-	ns
RESET input low width	t_{RSL}	Input	-	1000	-	ns
V-sync pulse width	t_{VW}	-	4	-	-	μs
H-sync pulse width	t_{HW}	-	3	-	-	μs
Noise filter	t_{NF1}	P2.0-P2.3	-	300	-	ns
	t_{NF4}	Glitch filter (oscillator block)		1000		
	t_{NF3}	RESET		1000		
	t_{NF2}	H-sync, V-sync		300		

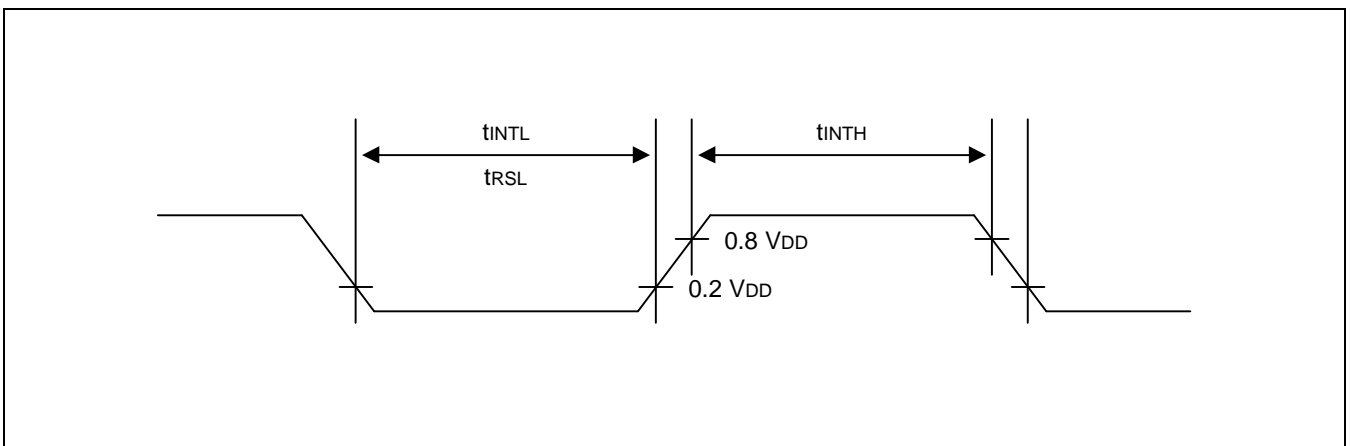

Figure 17-1. Input Timing measurement points

Table 17-4. Input/Output Capacitance

(T_A = -40 °C to +85 °C, V_{DD} = 0 V)

Parameter	Symbol	Conditions	Min	Typ	Max	Unit
Input capacitance	C _{IN}	f = 1 MHz; unmeasured pins are returned to V _{SS}	-	-	10	pF
Output capacitance	C _{OUT}					
I/O capacitance	C _{IO}					

Table 17-5. Data Retention Supply Voltage in Sleep Mode

(T_A = -20 °C to +85 °C, V_{DD} = 4.5 V to 5.5 V)

Parameter	Symbol	Conditions	Min	Typ	Max	Unit
Data retention supply voltage	V _{DDDR}	Sleep mode	2	-	-	V
Data retention supply current	I _{DDDR}	Sleep mode V _{DDDR} = 5.0 V	-	-	2	mA

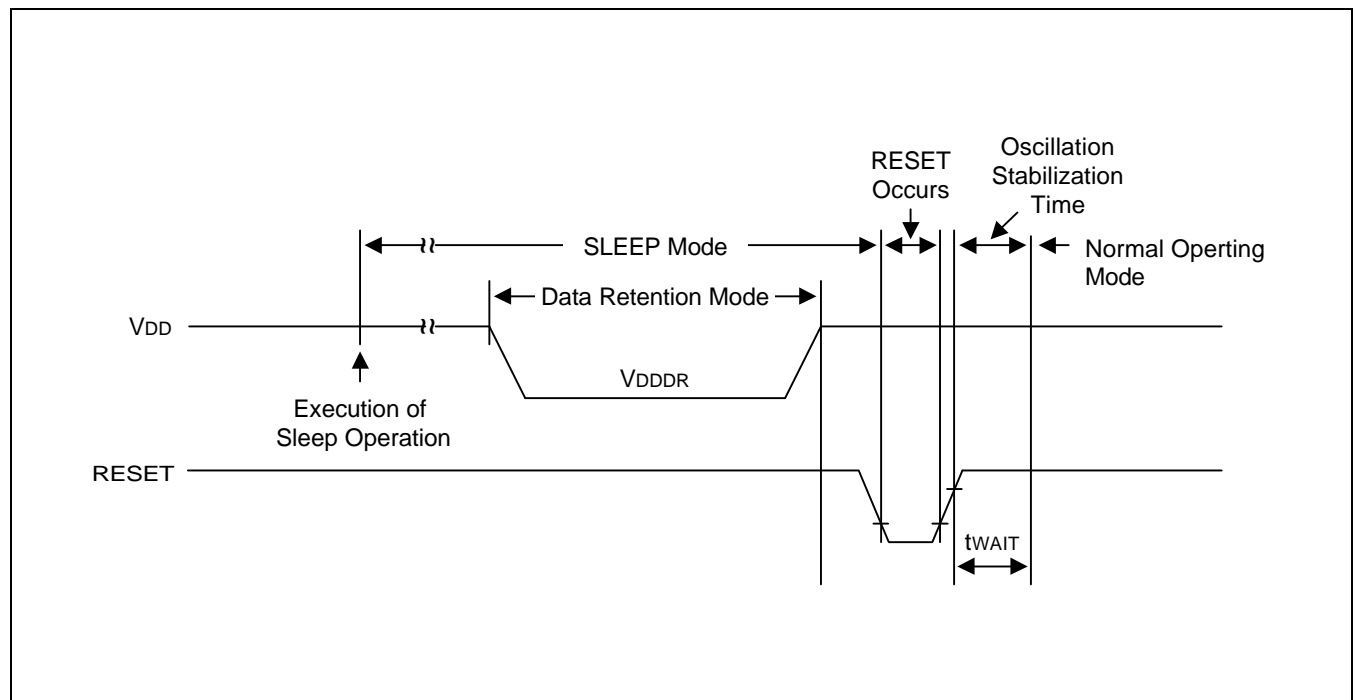

Figure 17-2. Sleep Mode Release Timing When Initiated by RESET

Table 17-6. Oscillator Frequency

(T_A = -20 °C + 85 °C)

Oscillator	Clock Circuit	Test Condition	Min	Typ	Max	Unit
Crystal or ceramic		V _{DD} = 4.5 V to 5.5 V C1 = C2 = 33 pF recommended	–	32,768	–	Hz
External clock		V _{DD} = 4.5 V to 5.5 V	–	32,768	–	Hz

Table 17-7. Oscillator Clock Stabilization Time

(T_A = -20 °C + 85 °C, V_{DD} = 4.5 V to 5.5 V)

Oscillator	Test Condition	Min	Typ	Max	Unit
Crystal	X _{IN} = 32,768 Hz	–	–	20	ms
External clock	X _{IN} input high and low level width (t _{XH} , t _{XL})	15	–	125	ns
Oscillator stabilization time	t _{WAIT} when released by a reset, X _{IN} = 32,768 Hz	–	–	500	ms
	t _{WAIT} when released by a interrupt ^(note)	–	–	4	ms

NOTE: The duration of the oscillator stabilization time, t_{WAIT}, when it is released by an interrupt, is determined by the settings in the basic timer control register, BTCON.

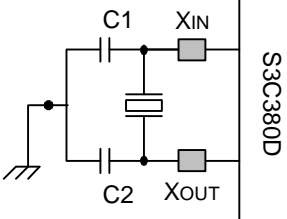
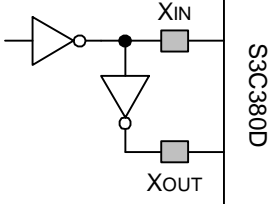
Table 17-8. A/D Converter Electrical Characteristics

(T_A = -20 °C to +85 °C, V_{DD} = 4.5 V to 5.5 V (ADC1-ADC4), V_{DD} = 5.0 V (ADC0))

Parameter	Symbol	Conditions	Min	Typ	Max	Unit	
Resolution	–	–	–	–	4	Bit	
Absolute accuracy (1)	–	CPU clock = 16 MHz	ADC0	–	–	± 1.0	LSB
			ADC1-4	–	–	± 0.5	LSB
Conversion Time (2)	t _{CON}	CPU clock = 16 MHz	–	(3)	–	ns	
Analog input voltage	V _{IAN}	–	ADC1-4	A _{VSS}	–	A _{VREF}	V
			ADC0	1.5	–	2.0	V
Analog input impedance	R _{AN}	–	2	–	–	MΩ	
Analog output impedance	R _{OAN}	CPU clock = 16 MHz Conversion time = 4 MHz	–	–	5	KΩ	
		CPU clock = 16 MHz Conversion time = 0.5, 1, and 2 MHz	–	–	10	KΩ	

NOTES:

1. Excluding quantization error, absolute accuracy values are within ± 1 LSB (ADC0), ± 0.5 LSB (ADC1-4)
2. 'Conversion time' is the time required from the moment a conversion operation starts until it ends
3. ADC conversion time is controlled by ADCON.9-8.

18 MECHANICAL DATA

OVERVIEW

The S3C380D microcontroller is currently available in 42-pin SDIP (42-SDIP-600) package.

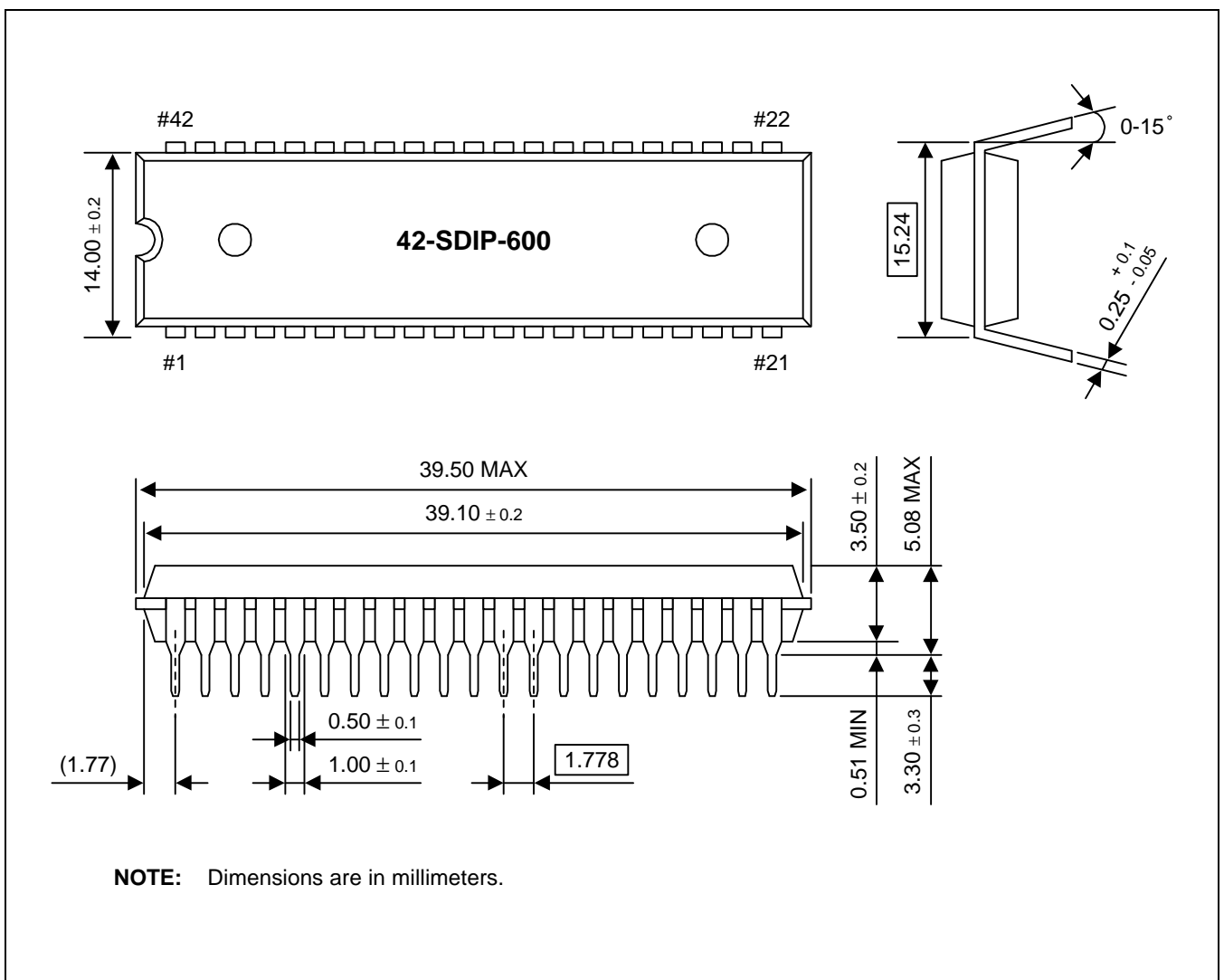

Figure 18-1. 42-Pin SDIP Package Dimensions

19

S3F380D MTP

OVERVIEW

The S3F380D single-chip CMOS microcontroller is the MTP (Multiple Time Programmable) version of the S3C380D microcontroller. It has an on-chip Flash ROM instead of a masked ROM. The flash ROM is accessed by serial data format.

The S3F380D is fully compatible with the S3C380D, both in function and pin configuration.

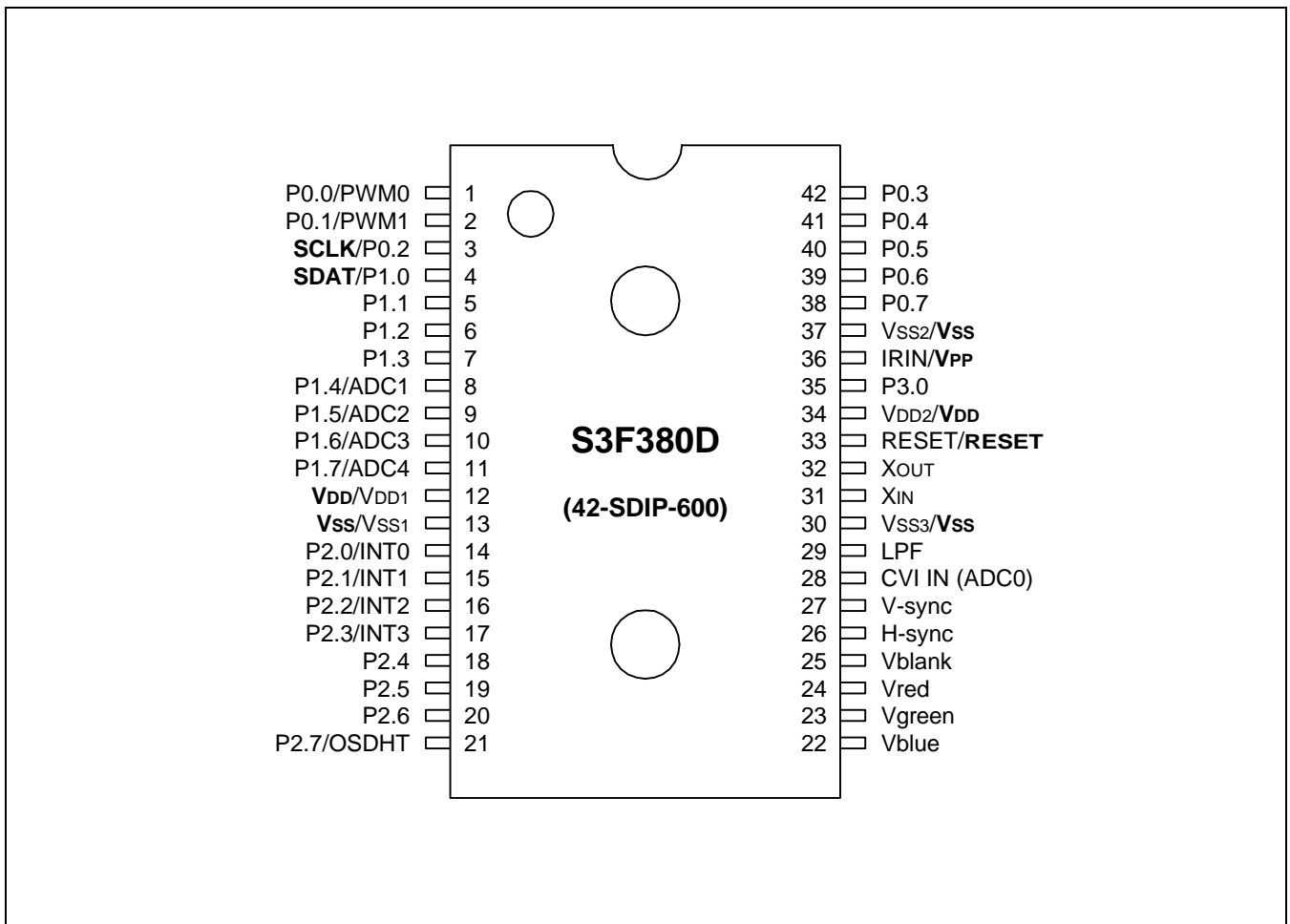

Figure 19-1. S3F380D Pin Assignment (42-SDIP)

Table 19-1. Descriptions of Pins Used to Read/Write the Flash ROM (S3F380D)

Main Chip Pin Name	During Programming			
	Pin Name	Pin No.	I/O	Function
P1.0 (Pin 4)	SDAT	4	I/O	Serial data pin (output when reading, Input when writing) Input and push-pull output port can be assigned
P0.2 (Pin 3)	SCLK	3	I/O	Serial clock pin (Input only pin)
IRIN	V _{PP}	36	I	0-5 V: operating mode 12.5 V: MTP mode
RESET	RESET	33	I	5 V: operating mode, 0 V: MTP mode
V _{DD} /V _{SS}	V _{DD} /V _{SS}	12/34, 13/30/37	I	Logic power supply pin.

Table 19-2. Comparison of S3F380D and S3C380D Features

Characteristic	S3F380D	S3C380D
Program Memory	128-Kbyte Flash ROM	128-Kbyte mask ROM
Operating Voltage (V _{DD})	4.5 V to 5.5 V	4.5 V to 5.5 V
MTP Programming Mode	V _{DD} = 5 V, V _{PP} = 12.5 V	–
Pin Configuration	42 SDIP	42 SDIP
Flash ROM programmability	User program under 100 time	Programmed at the factory