

# 1

## PRODUCT OVERVIEW

### OVERVIEW

The S3C7515/P7515 single-chip CMOS microcontroller has been designed for high-performance using Samsung's newest 4-bit CPU core, SAM47 (Samsung Arrangeable Microcontrollers). The S3P7515 is a microcontroller which has 16-kbyte one-time-programmable EPROM but its functions are same to S3C7515.

With its DTMF generator, 8-bit serial I/O interface, and versatile 8-bit timer/counters, the S3C7515/P7515 offers an excellent design solution for a wide variety of telecommunication applications.

Up to 55 pins of the 64-pin SDIP or QFP package can be dedicated to I/O. Seven vectored interrupts provide fast response to internal and external events. In addition, the S3C7515/P7515's advanced CMOS technology provides for low power consumption and a wide operating voltage range.

### DEVELOPMENT SUPPORT

The Samsung Microcontroller Development System, SMDS, provides you with a complete PC-based development environment for S3C7-series microcontrollers that is powerful, reliable, and portable. In addition to its window-based program development structure, the SMDS tool set includes versatile debugging, trace, instruction timing, and performance measurement applications. The Samsung Generalized Assembler (SAMA) has been designed specifically for the SMDS environment and accepts assembly language sources in a variety of microprocessor formats. SAMA generates industry-standard hex files that also contain program control data for SMDS compatibility.

## FEATURES SUMMARY

### Memory

- 512 × 4-bit RAM
- 16,384 × 8-bit ROM

### 55 I/O Pins

- Input only: 4 pins
- I/O: 43 pins
- N-channel open-drain I/O: 8 pins

### Memory-Mapped I/O Structure

- Data memory bank 15

### DTMF Generator

- 16 dual-tone frequencies for tone dialing

### 8-bit Basic Timer

- 4 interval timer functions

### Two 8-bit Timer/Counters

- Programmable interval timer
- External event counter function
- Timer/counters clock outputs to TCLO0 and TCLO1 pins
- External clock signal divider
- Serial I/O interface clock generator

### Watch Timer

- Time interval generation: 0.5 s, 3.9 ms at 32.768 kHz
- 4 frequency outputs to the BUZ pin

### 8-bit Serial I/O Interface

- 8-bit transmit/receive mode
- 8-bit receive mode
- LSB-first or MSB-first transmission selectable

### Bit Sequential Carrier

- Supports 8-bit serial data transfer in arbitrary format

### Interrupts

- 3 external interrupt vectors
- 4 internal interrupt vectors
- 2 quasi-interrupts

### Power-Down Modes

- Idle: Only CPU clock stops
- Stop: System clock stops

### Oscillation Sources

- Crystal, ceramic for main system clock
- Crystal oscillator for subsystem clock
- Main system clock frequency: 3.579545 MHz (typical)
- Subsystem clock frequency: 32.768 kHz (typical)
- CPU clock divider circuit (by 4, 8, or 64)

### Instruction Execution Times

- 0.67, 1.33, 10.7  $\mu$ s at 6.0 MHz
- 1.12, 2.23, 17.88  $\mu$ s at 3.579545 MHz
- 122  $\mu$ s at 32.768 kHz

### Operating Temperature

- -40 °C to 85 °C

### Operating Voltage Range

- 2.0 V to 5.5 V

### Package Types

- 64 SDIP, 64 QFP

## FUNCTION OVERVIEW

### SAM47 CPU

All S3C7-series microcontrollers have the advanced SAM47 CPU core. The SAM47 CPU can directly address up to 32 K bytes of program memory. The arithmetic logic unit (ALU) performs 4-bit addition, subtraction, logical, and shift-and-rotate operations in one instruction cycle and most 8-bit arithmetic and logical operations in two cycles.

### CPU REGISTERS

#### Program Counter

A 14-bit program counter (PC) stores addresses for instruction fetches during program execution. Usually, the PC is incremented by the number of bytes of the fetched instruction. The one instruction fetch that does not increment the PC is the 1-byte REF instruction which references instructions stored in a look-up table in the ROM. Whenever a reset operation or an interrupt occurs, bits PC13 through PC0 are set to the vector address.

#### Stack Pointer

An 8-bit stack pointer (SP) stores addresses for stack operations. The stack area is located in general-purpose data memory bank 0. The SP is 8-bit read/writeable and SP bit 0 must always be logic zero.

During an interrupt or a subroutine call, the PC value and the PSW are written to the stack area. When the service routine has completed, the values referenced by the stack pointer are restored. Then, the next instruction is executed.

The stack pointer can access the stack despite data memory access enable flag status. Since the reset value of the stack pointer is not defined in firmware, you use program code to initialize the stack pointer to 00H. This sets the first register of the stack area to data memory location 0FFH.

### PROGRAM MEMORY

In its standard configuration, the 16,384 × 8-bit ROM is divided into four areas:

- 16-byte area for vector addresses
- 16-byte general-purpose area (0010–001FH)
- 96-byte instruction reference area
- 16,256-byte area for general-purpose program memory

The vector address area is used mostly during reset operations and interrupts. These 16 bytes can alternately be used as general-purpose ROM.

The REF instruction references 2 × 1-byte or 2-byte instructions stored in reference area locations 0020H–007FH. REF can also reference three-byte instructions such as JP or CALL. So that a REF instruction can reference these instructions, however, the JP or CALL must be shortened to a 2-byte format. To do this, JP or CALL is written to the reference area with the format TJP or TCALL instead of the normal instruction name. Unused locations in the REF instruction look-up area can be allocated to general-purpose use.

## DATA MEMORY

### Overview

The  $512 \times 4$  bit data memory has four areas:

- $32 \times 4$ -bit working register area
- $224 \times 4$ -bit general-purpose area in bank 0 which is also used as the stack area
- $256 \times 4$ -bit general-purpose area in bank 1
- $128 \times 4$ -bit area in bank 15 for memory-mapped I/O addresses

The data memory area is also organized as three memory banks — bank 0, bank 1, and bank 15. You use the select memory bank instruction (SMB) to select one of the banks as working data memory.

Data stored in RAM locations are 1-, 4-, and 8-bit addressable. After a hardware reset, data memory initialization values must be defined by program code.

### Data Memory Addressing Modes

The enable memory bank (EMB) flag controls the addressing mode for data memory banks 0, 1, or 15. When the EMB flag is logic zero, only locations 00H–7FH of bank 0 and bank 15 can be accessed. When the EMB flag is set to logic one, all three data memory banks can be accessed based on the current SMB value.

### Working Registers

The RAM's working register area in data memory bank 0 is also divided into four *register* banks. Each register bank has eight 4-bit registers. Paired 4-bit registers are 8-bit addressable.

Register A can be used as a 4-bit accumulator and double register EA as an 8-bit extended accumulator; double registers WX, WL, and HL are used as address pointers for indirect addressing.

To limit the possibility of data corruption due to incorrect register addressing, it is advisable to use bank 0 for main programs and banks 1, 2, and 3 for interrupt service routines.

### Bit Sequential Carrier

The bit sequential carrier (BSC) mapped in data memory bank 15 is a 8-bit general register that you can manipulate using 1-, 4-, and 8-bit RAM control instructions.

Using the BSC register, addresses and bit locations can be specified sequentially using 1-bit indirect addressing instructions. In this way, a program can generate 8-bit data output by moving the bit location sequentially, incrementing or decrementing the value of the L register. You can also use direct addressing to manipulate data in the BSC.

## CONTROL REGISTERS

### Program Status Word

The 8-bit program status word (PSW) controls ALU operations and instruction execution sequencing. It is also used to restore a program's execution environment when an interrupt has been serviced. Program instructions can always address the PSW regardless of the current value of data memory access enable flags.

Before an interrupt is processed, the PSW is pushed onto the stack in data memory bank 0. When the routine is completed, PSW values are restored.

IS1	IS0	EMB	ERB
C	SC2	SC1	SC0

Interrupt status flags (IS1, IS0), the enable memory bank and enable register bank flags (EMB, ERB), and the carry flag (C) are 1- and 4-bit read/write or 8-bit read-only addressable. Skip condition flags (SC0–SC2) can be addressed using 8-bit read instructions only.

### Select Bank (SB) Register

Two 4-bit locations called the SB register store address values used to access specific memory and register banks: the select memory bank register, SMB, and the select register bank register, SRB.

'SMB n' instructions select a data memory bank (0, 1, or 15) and store the upper four bits of the 12-bit data memory address in the SMB register. The 'SRB n' instruction is used to select register bank 0, 1, 2, or 3, and to store the address data in the SRB.

The instructions 'PUSH SB' and 'POP SB' move SMB and SRB values to and from the stack for interrupts and subroutines.

## CLOCK CIRCUITS

Main system and subsystem oscillation circuits generate the internal clock signals for the CPU and peripheral hardware. The main system clock can use a crystal, ceramic, or RC oscillation source, or an externally-generated clock signal. The subsystem clock requires either a crystal oscillator or an external clock source.

Bit settings in the 4-bit power control and system clock mode registers select the oscillation source, the CPU clock, and the clock used during power-down mode. The internal system clock signal (f<sub>xx</sub>) can be divided internally to produce three CPU clock frequencies — f<sub>xx</sub>/4, f<sub>xx</sub>/8, or f<sub>xx</sub>/64.

## INTERRUPTS

Interrupt requests may be generated internally by on-chip processes (INTB, INTT0, INTT1, and INTS) or externally by peripheral devices (INT0, INT1, and INT4). There are two quasi-interrupts: INT2 and INTW.

INT2/KS0–KS7 detects rising/falling edges of incoming signals and INTW detects time intervals of 0.5 seconds or 3.91 milliseconds at the watch timer clock frequency of 32.768 kHz. The following components support interrupt processing:

- Interrupt enable flags
- Interrupt request flags
- Interrupt priority registers
- Power-down termination circuit

## POWER-DOWN

To reduce power consumption, there are two power-down modes: idle and stop. The IDLE instruction initiates idle mode and the STOP instruction initiates stop mode.

In idle mode, only the CPU clock stops while peripherals and the oscillation source continue to operate normally. Stop mode effects only the main system clock — a subsystem clock, if used, continues oscillating. In stop mode, main system clock oscillation stops completely, halting all operations except for a few basic peripheral functions. RESET or an interrupt (with the exceptions of INT0) can be used to terminate either idle or stop mode.

## RESET

When a RESET signal occurs during normal operation or during power-down mode, the CPU enters idle mode when the reset operation is initiated. When the standard oscillation stabilization interval (36.6 ms at 3.579545 MHz) has elapsed, normal CPU operation resumes.

## I/O PORTS

The S3C7515/P7515 has 14 I/O ports. Pin addresses for all I/O ports are mapped in bank 15 of the RAM. There are 4 input pins, 43 configurable I/O pins, and 8 n-channel open-drain I/O pins, for a total of 55 I/O pins. The contents of I/O port pin latches can be read, written, or tested at the corresponding address using bit manipulation instructions.

## TIMERS and TIMER/COUNTERS

The timer function has four main components: an 8-bit basic interval timer, two 8-bit timer/counters, and a watch timer. The 8-bit basic timer generates interrupt requests at precise intervals, based on the selected CPU clock frequency.

The programmable 8-bit timer/counters are used for external event counting, generation of arbitrary clock frequencies for output, and dividing external clock signals. The 8-bit timer/counter 0 generates a clock signal (SCK) for the serial I/O interface.

The watch timer has an 8-bit watch timer mode register, a clock selector, and a frequency divider circuit. Its functions include real-time and watch-time measurement, and frequency outputs for buzzer sound.

## SERIAL I/O INTERFACE

The serial I/O interface supports the transmission or reception of 8-bit serial data with an external device. The serial interface has the following functional components:

- 8-bit mode register
- Clock selector circuit
- 8-bit buffer register
- 3-bit serial clock counter

The serial I/O circuit can be set either to transmit-and-receive or to receive-only mode. MSB-first or LSB-first transmission is also selectable. The serial interface operates with an internal or an external clock source, or using the clock signal generated by the 8-bit timer/counter 0. To modify transmission frequency, the appropriate bits in the serial I/O mode register (SMOD) must be manipulated.

BLOCK DIAGRAM

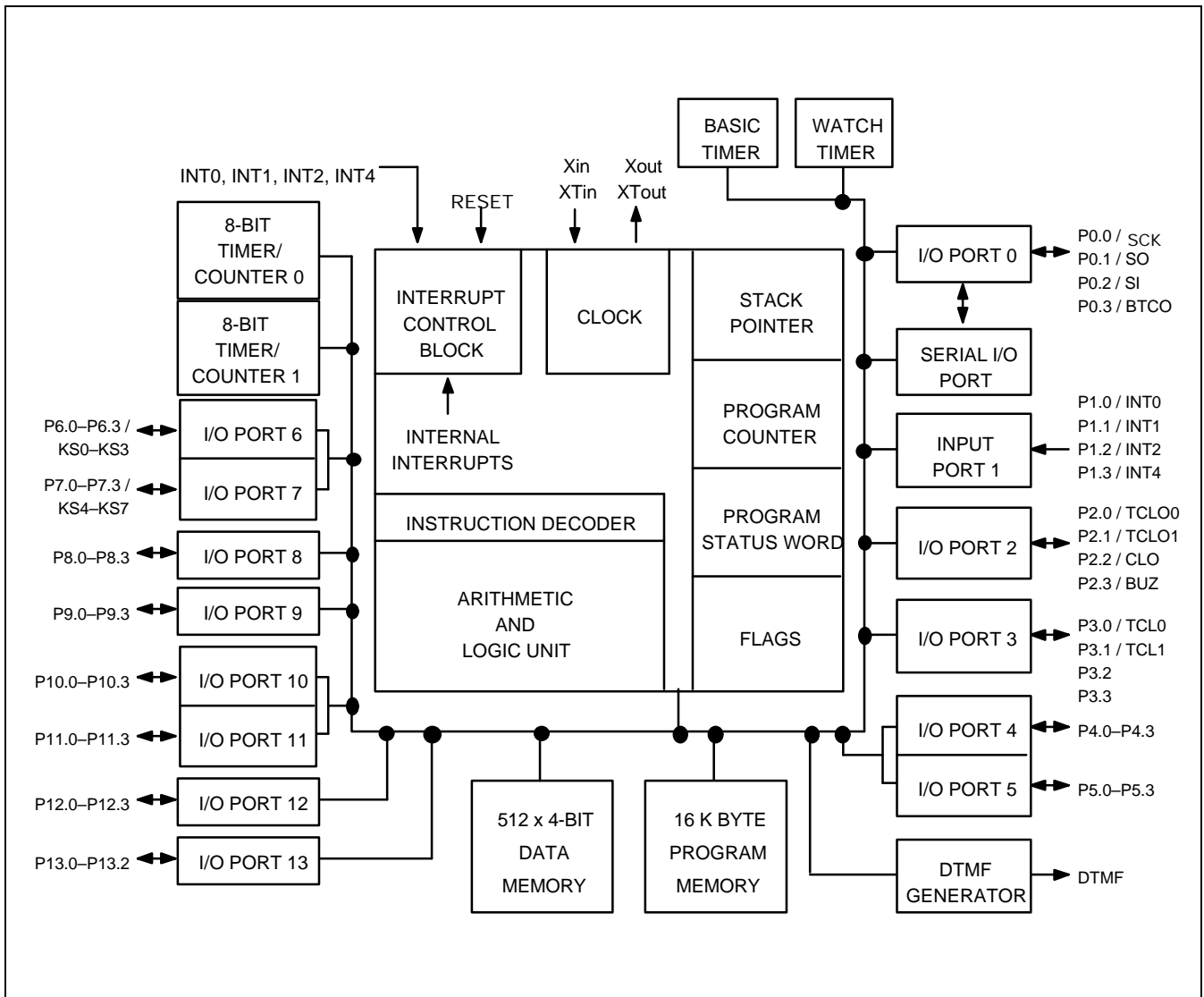
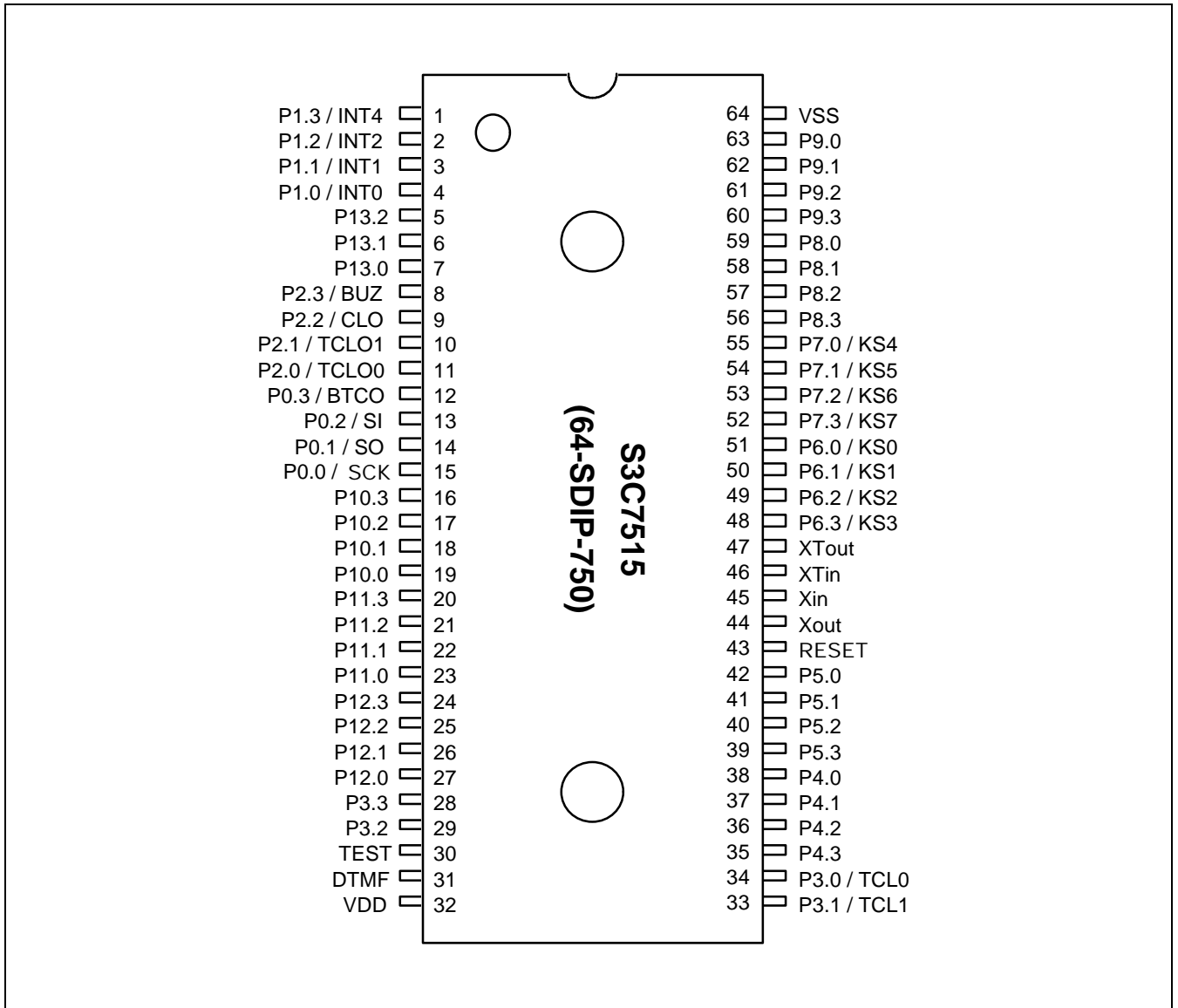

Figure 1-1. S3C7515/P7515 Simplified Block Diagram

**PIN ASSIGNMENTS**



**Figure 1-2. 64-SDIP Pin Assignment Diagrams**



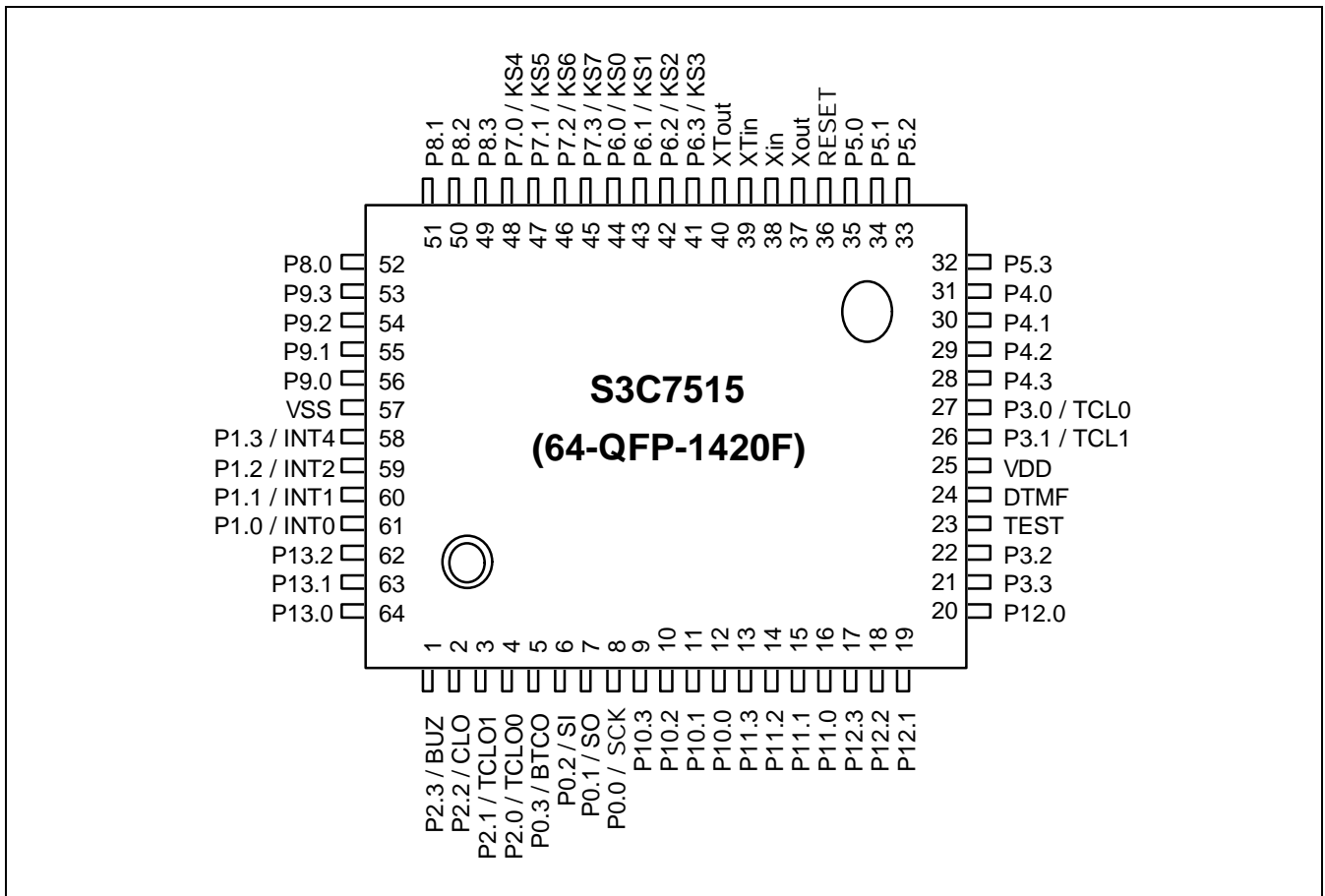

Figure 1-2. 64-QFP Pin Assignment Diagrams (Continued)

## PIN DESCRIPTIONS

Table 1-1. S3C7515/P7515 Pin Descriptions

Pin Name	Pin Type	Description	Number	Share Pin
P0.0 P0.1 P0.2 P0.3	I/O	4-bit I/O port. 1-bit or 4-bit read/write and test is possible. Individual pins are software configurable as input or output. 4-bit pull-up resistors are software assignable; pull-up resistors are automatically disabled for output pins.	15 (8) 14 (7) 13 (6) 12 (5)	SCK SO SI BTCO
P1.0 P1.1 P1.2 P1.3	I	4-bit input port. 1-bit and 4-bit read and test is possible. 4-bit pull-up resistors are assignable by software to pins P1.0, P1.1, P1.2 and P1.3.	1 (61) 2 (60) 3 (59) 4 (58)	INT0 INT1 INT2 INT4
P2.0 P2.1 P2.2 P2.3	I/O	Same as port 0.	11 (4) 10 (3) 9 (2) 8 (1)	TCLO0 TCLO1 CLO BUZ
P3.0 P3.1 P3.2 P3.3	I/O	Same as port 0.	34 (27) 33 (26) 29 (22) 28 (21)	TCL0 TCL1
P4.0–P4.3 P5.0–P5.3	I/O	4-bit I/O ports. N-channel open-drain output up to 9 volts. 1-bit and 4-bit read/write and test is possible. Ports 4 and 5 can be paired to support 8-bit data transfer. 8-bit unit pull-up resistors are assignable by mask option.	38–35 (31–28) 42–39 (35–32)	–
P6.0–P6.3 P7.0–P7.3	I/O	4-bit I/O ports. 1-bit or 4-bit read/write and test is possible. Port 6 pins are individually software configurable as input or output. 4-bit pull-up resistors are software assignable; pull-up resistors are automatically disabled for output pins (port 6 only). Ports 6 and 7 can be paired to enable 8-bit data transfer.	51–48 (44–41) 55–52 (48–45)	KS0–KS3 KS4–KS7
P8.0–P8.3	I/O	Same as port 0.	59–56 (52–49)	–
P9.0–P9.3	I/O	4-bit I/O port. 1-bit or 4-bit read/write and test is possible. 4-bit pull-up resistors are software assignable; pull-up resistors are automatically disabled for output pins.	63–60 (56–53)	–

\* Parentheses indicate pin number for 64 QFP package.

Table 1-1. S3C7515/P7515 Pin Descriptions (Continued)

Pin Name	Pin Type	Description	Number	Share Pin
P10.0–P10.3 P11.0–P11.3	I/O	Same as port 9. Ports 10 and 11 can be paired to support 8-bit data transfer.	19–16 (12–9) 23–20 (16–13)	–
P12.0–P12.3	I/O	4-bit I/O port. 1-bit or 4-bit read/write and test is possible. Individual pins are software configurable as input or output. 4-bit <i>pull-down</i> resistors are software assignable; pull-down resistors are automatically disabled for output pins.	27–24 (20–17)	–
P13.0–P13.2	I/O	3-bit I/O port; characteristics are same as port 9.	7–5 (64–62)	–
DTMF	O	DTMF output.	31 (24)	–
SCK	I/O	Serial I/O interface clock signal	15 (8)	P0.0
SO	I/O	Serial data output	14 (7)	P0.1
SI	I/O	Serial data input	13 (6)	P0.2
BTCO	I/O	Basic timer clock output	12 (5)	P0.3
INT0, INT1	I	External interrupts. The triggering edge for INT0 and INT1 is selectable. INT0 is synchronized to system clock.	4, 3 (61, 60)	P1.0, P1.1
INT2	I	Quasi-interrupt with detection of rising edges	2 (59)	P1.2
INT4	I	External interrupt with detection of rising and falling edges.	1 (58)	P1.3
TCLO0	I/O	Timer/counter 0 clock output	11 (4)	P2.0
TCLO1	I/O	Timer/counter 1 clock output	10 (3)	P2.1
CLO	I/O	Clock output	9 (2)	P2.2
BUZ	I/O	2 kHz, 4 kHz, 8 kHz, or 16 kHz frequency output at the watch timer clock frequency of 32.768 kHz for buzzer sound	8 (1)	P2.3
TCL0	I/O	External clock input for timer/counter 0	34 (27)	P3.0
TCL1	I/O	External clock input for timer/counter 1	33 (26)	P3.1
KS0–KS3 KS4–KS7	I/O	Quasi-interrupt inputs with falling edge detection	51–48 (44–41) 55–52 (48–45)	P6.0–P6.3 P7.0–P7.3

\* Parentheses indicate pin number for 64 QFP package.

Table 1-1. S3C7515/P7515 Pin Descriptions (Concluded)

Pin Name	Pin Type	Description	Number	Share Pin
$V_{DD}$	–	Power supply	32 (25)	–
$V_{SS}$	–	Ground	64 (57)	–
RESET	I	Reset signal	43 (36)	–
$X_{IN}$ , $X_{OUT}$	–	Crystal, ceramic, or R/C oscillator signal for main system clock. (For external clock input, use $X_{IN}$ and input $X_{IN}$ 's reverse phase to $X_{OUT}$ )	45, 44 (38, 37)	–
$XT_{IN}$ , $XT_{OUT}$	–	Crystal oscillator signal for subsystem clock. (For external clock input, use $XT_{IN}$ and input $XT_{IN}$ 's reverse phase to $XT_{OUT}$ )	46, 47 (39, 40)	–
NC	–	No connection (must be connected to $V_{SS}$ )	30 (23)	–

\* Parentheses indicate pin number for 64 QFP package.

Table 1-2. Overview of S3C7515/P7515 Pin Data

Pin Names	Share Pins	I/O Type	Reset Value	Circuit Type
P0.0–P0.3	SCK, SO, SI, BTCO	I/O	Input	D-4
P1.0–P1.3	INT0, INT1, INT2, INT4	I	Input	A-3
P2.0–P2.3	TCLO0, TCLO1, CLO, BUZ	I/O	Input	D-2
P3.0–P3.1	TCL0, TCL1	I/O	Input	D-4
P3.2–P3.3	–	I/O	Input	D-2
P4.0–P4.3 P5.0–P5.3	–	I/O	(NOTE)	E-6
P6.0–P6.3 P7.0–P7.3	KS0–KS3 KS4–KS7	I/O	Input	D-4
P8.0–P8.3	–	I/O	Input	D-2
P9.0–P9.3	–	I/O	Input	D-2
P10.0–P10.3 P11.0–P11.3	–	I/O	Input	D-2
P12.0–P12.3	–	I/O	Input	D-6
P13.0–P13.2	–	I/O	Input	D-2
DTMF	–	O	High impedance	G-6
X <sub>IN</sub> , X <sub>OUT</sub> XT <sub>IN</sub> , XT <sub>OUT</sub>	–	–	–	–
RESET	–	I	–	B
NC	–	–	–	–
V <sub>DD</sub> , V <sub>SS</sub>	–	–	–	–

**NOTE:** When pull-up resistors are provided: High level  
 When pull-up resistors are not provided: High impedance

**PIN CIRCUIT DIAGRAMS**

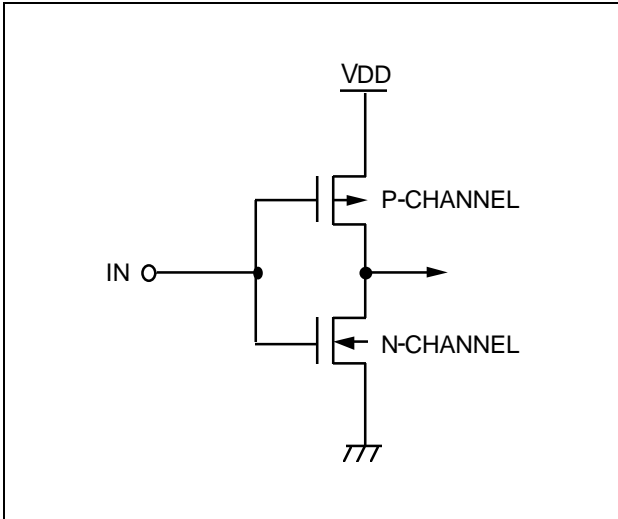

**Figure 1-3. Pin Circuit Type A**

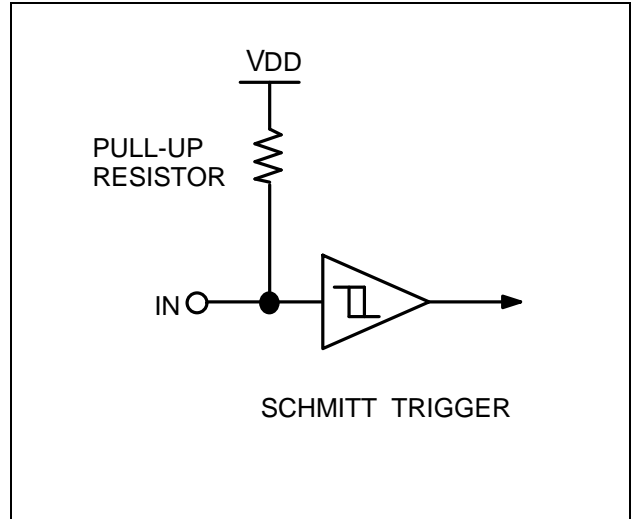

**Figure 1-5. Pin Circuit Type B**

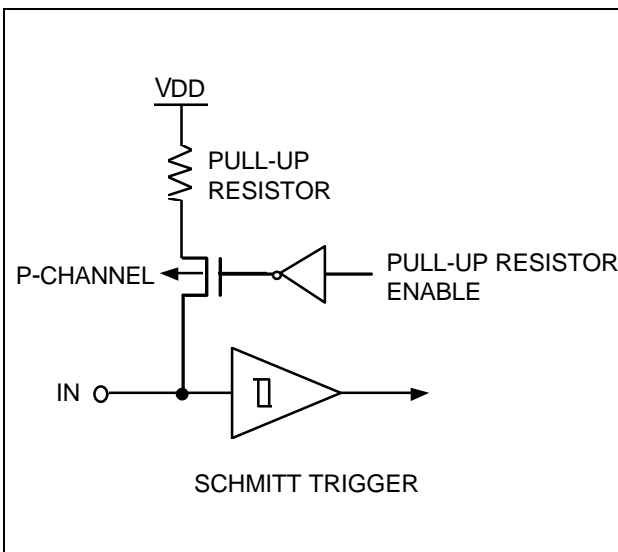

**Figure 1-4. Pin Circuit Type A-3**

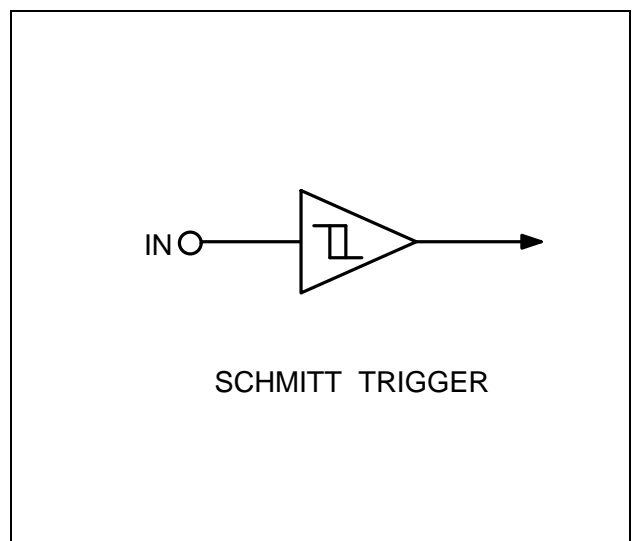

**Figure 1-6. Pin Circuit Type B-4**

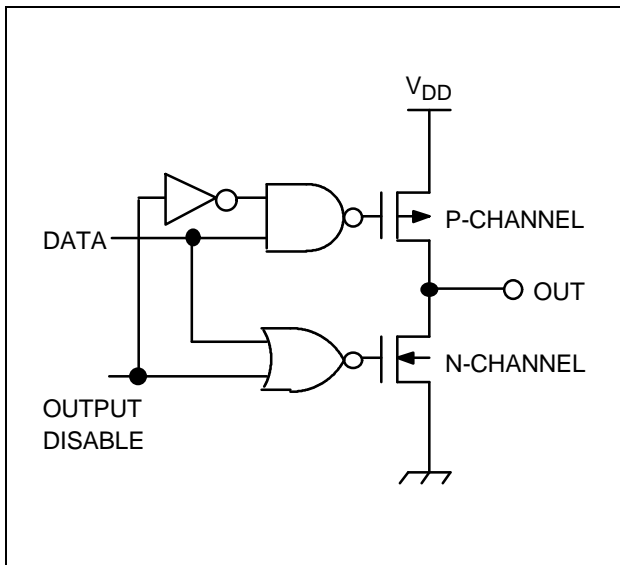

Figure 1-7. Pin Circuit Type C

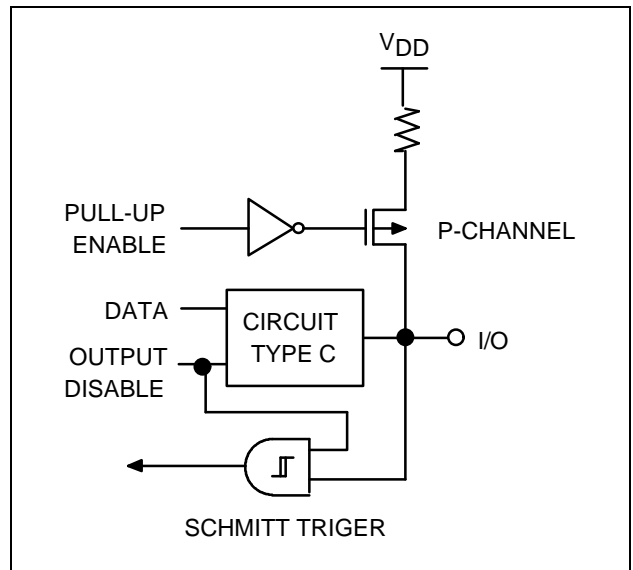

Figure 1-9. Pin Circuit Type D-4

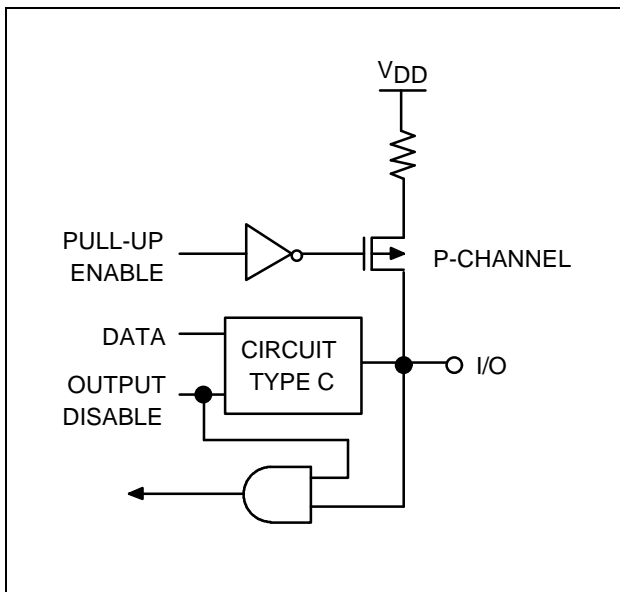

Figure 1-8. Pin Circuit Type D-2

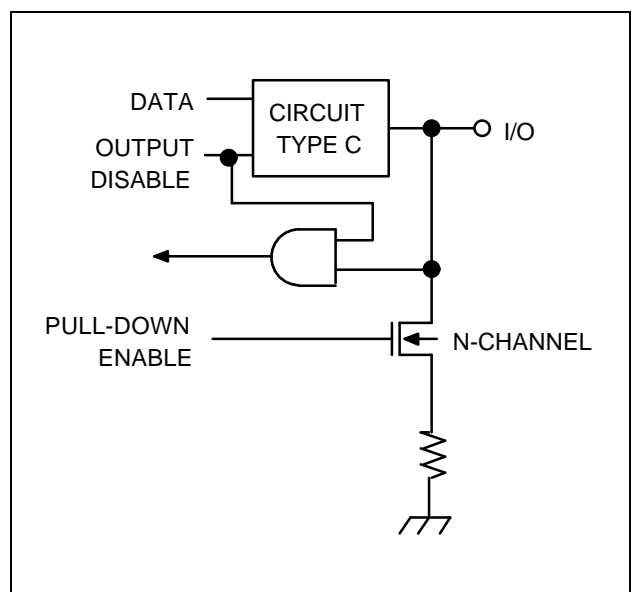

Figure 1-10. Pin Circuit Type D-6

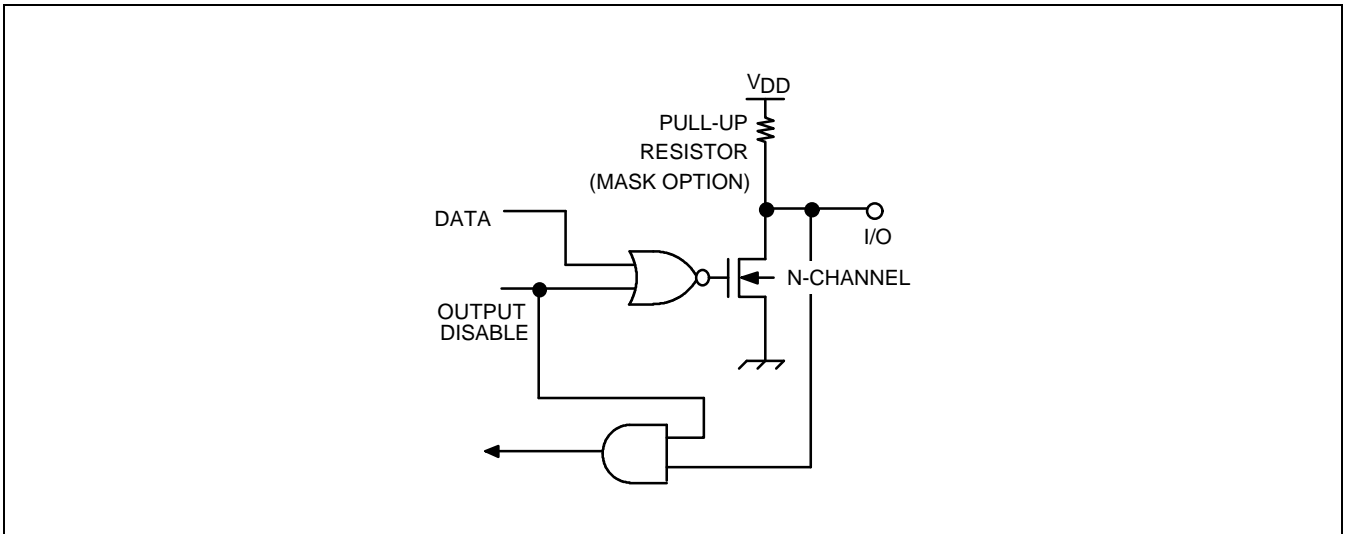

Figure 1-11. Pin Circuit Type E-6

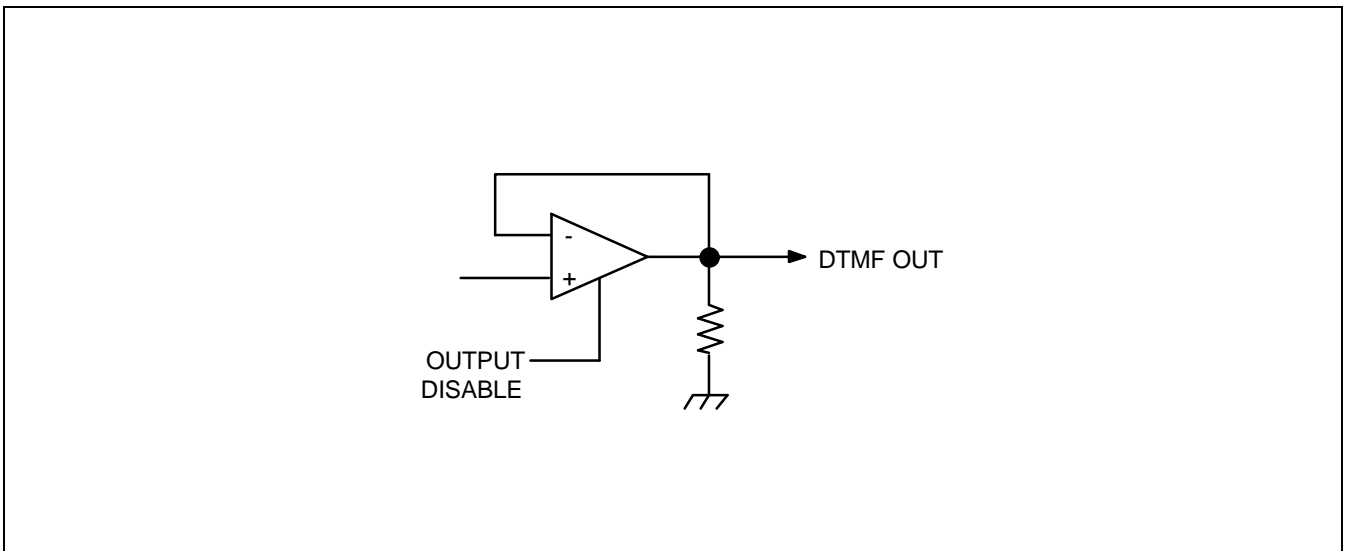

Figure 1-12. Pin Circuit Type G-2



# 14 ELECTRICAL DATA

In this section, information on S3C7515 electrical characteristics is presented as tables and graphics. The information is arranged in the following order:

## Standard Electrical Characteristics

- Absolute maximum ratings
- D.C. electrical characteristics
- System clock oscillator characteristics
- I/O capacitance
- A.C. electrical characteristics
- Operating voltage range

## Miscellaneous Timing Waveforms

- A.C timing measurement point
- Clock timing measurement at  $X_{in}$  and  $X_{out}$
- TCL timing
- Input timing for RESET
- Input timing for external interrupts
- Serial data transfer timing

## Stop Mode Characteristics and Timing Waveforms

- RAM data retention supply voltage in stop mode
- Stop mode release timing when initiated by RESET
- Stop mode release timing when initiated by an interrupt request

Table 14-1. Absolute Maximum Ratings

(T<sub>A</sub> = 25 °C)

Parameter	Symbol	Conditions	Rating	Units
Supply Voltage	V <sub>DD</sub>	–	-0.3 to 6.5	V
Input Voltage	V <sub>I1</sub>	All I/O ports	- 0.3 to V <sub>DD</sub> + 0.3	V
Output Voltage	V <sub>O</sub>	–	- 0.3 to V <sub>DD</sub> + 0.3	V
Output Current High	I <sub>OH</sub>	One I/O port active	- 15	mA
		All I/O ports active	- 30	
Output Current Low	I <sub>OL</sub>	One I/O port active	+ 30 (Peak value)	mA
			+ 15 *	
		All I/O ports, total	+ 100 (Peak value)	
			+ 60 *	
Operating Temperature	T <sub>A</sub>	–	- 40 to + 85	°C
Storage Temperature	T <sub>stg</sub>	–	- 65 to + 150	°C

\* The values for Output Current Low ( I<sub>OL</sub> ) are calculated as Peak Value × √Duty .

Table 14-2. D.C. Electrical Characteristics

(T<sub>A</sub> = - 40 °C to + 85 °C, V<sub>DD</sub> = 2.0 V to 5.5 V)

Parameter	Symbol	Conditions	Min	Typ	Max	Units
Input High Voltage	V <sub>IH1</sub>	All input pins except those specified below for V <sub>IH2</sub> - V <sub>IH4</sub>	0.7 V <sub>DD</sub>	–	V <sub>DD</sub>	V
	V <sub>IH2</sub>	Ports 0, 1, 3, 6, 7, and RESET	0.8 V <sub>DD</sub>		V <sub>DD</sub>	
	V <sub>IH3</sub>	Ports 4 and 5 with pull-up resistors assigned	0.7 V <sub>DD</sub>		V <sub>DD</sub>	
		Ports 4 and 5 are open-drain	0.7 V <sub>DD</sub>		V <sub>DD</sub>	
	V <sub>IH4</sub>	X <sub>IN</sub> , X <sub>OUT</sub> and XT <sub>IN</sub>	V <sub>DD</sub> - 0.1		V <sub>DD</sub>	
Input Low Voltage	V <sub>IL1</sub>	All input pins except those specified below for V <sub>IL2</sub> - V <sub>IL3</sub>	–	–	0.3 V <sub>DD</sub>	V
	V <sub>IL2</sub>	Ports 0, 1, 3, 6, 7, and RESET			0.2 V <sub>DD</sub>	
	V <sub>IL3</sub>	X <sub>IN</sub> , X <sub>OUT</sub> and XT <sub>IN</sub>			0.1	

Table 14-2. D.C. Electrical Characteristics (Continued)

(T<sub>A</sub> = -40 °C to +85 °C, V<sub>DD</sub> = 2.0 V to 5.5 V)

Parameter	Symbol	Conditions	Min	Typ	Max	Units
Output High Voltage	V <sub>OH</sub>	I <sub>OH</sub> = -1 mA Ports except 1,4 and 5	V <sub>DD</sub> -1.0	-	-	V
Output Low Voltage	V <sub>OL1</sub>	V <sub>DD</sub> = 4.5 V to 5.5 V I <sub>OL</sub> = 15 mA Ports 4,5 only	-	-	2	V
		V <sub>DD</sub> = 2.0 to 5.5 V I <sub>OL</sub> = 1.6mA		-	0.4	V
	V <sub>OL2</sub>	V <sub>DD</sub> = 4.5 V to 5.5 V I <sub>OL</sub> = 4mA all out Ports except ports 4,5			2	V
		V <sub>DD</sub> = 2.0 to 5.5 V I <sub>OL</sub> = 1.6mA			0.4	V
Input High Leakage Current	I <sub>LIH1</sub>	V <sub>I</sub> = V <sub>DD</sub> All input pins except those specified below for I <sub>LIH2</sub>	-	-	3	μA
	I <sub>LIH2</sub>	V <sub>I</sub> = V <sub>DD</sub> X <sub>IN</sub> , X <sub>OUT</sub> and XT <sub>IN</sub>			20	
Input Low Leakage Current	I <sub>LIL1</sub>	V <sub>I</sub> = 0 V All input pins except below and RESET	-	-	- 3	μA
	I <sub>LIL2</sub>	V <sub>I</sub> = 0 V X <sub>IN</sub> , X <sub>OUT</sub> and XT <sub>IN</sub>			- 20	
Output High Leakage Current	I <sub>LOH</sub>	V <sub>O</sub> = V <sub>DD</sub> All output pins	-	-	3	μA
Output Low Leakage Current	I <sub>LOL</sub>	V <sub>O</sub> = 0 V All output pins	-	-	- 3	
Pull-Up Resistor	R <sub>L1</sub>	V <sub>DD</sub> = 5 V ; V <sub>I</sub> = 0 V except RESET and P4.5	25	47	100	kΩ
		V <sub>DD</sub> = 3 V	50	95	200	
	R <sub>L2</sub>	V <sub>O</sub> = V <sub>DD</sub> - 2V, V <sub>DD</sub> = 5V Ports 4 and 5 only	15	47	70	
		V <sub>DD</sub> = 3V	10	45	60	
	R <sub>L3</sub>	V <sub>DD</sub> = 5 V ; V <sub>I</sub> = 0 V; RESET	100	220	400	
		V <sub>DD</sub> = 3 V	200	450	800	
Pull-Down Resistor	R <sub>L4</sub>	V <sub>DD</sub> = 5 V ; V <sub>I</sub> = V <sub>DD</sub> ; Port 12	25	47	100	
		V <sub>DD</sub> = 3 V	50	95	200	

Table 14-2. D.C. Electrical Characteristics (Concluded)

(T<sub>A</sub> = -40 °C to +85 °C, V<sub>DD</sub> = 2.0 V to 5.5 V)

Parameter	Symbol	Conditions	Min	Typ	Max	Units	
Supply Current (1)	I <sub>DD1</sub> (DTMF ON)	Run mode; V <sub>DD</sub> =5.0V± 10% 3.58MHz Crystal oscillator; C1=C2=22pF	-	2.2	5.0	mA	
		V <sub>DD</sub> = 3 V ± 10%		1.2	3.0		
	I <sub>DD2</sub> (DTMF OFF)	Run mode; V <sub>DD</sub> =5.0V± 10% Crystal oscillator; C1=C2=22pF	6.0 MHz	-	3.9	8.0	
			3.58 MHz		2.0	4.0	
		V <sub>DD</sub> = 3 V ± 10%	6.0 MHz		1.8	4.0	
			3.58 MHz		0.8	2.3	
	I <sub>DD3</sub>	Idle mode; V <sub>DD</sub> = 5 V ± 10%	6.0 MHz	-	1.3	2.5	
			3.58 MHz		0.6	1.8	
		V <sub>DD</sub> = 3 V ± 10%	6.0 MHz		0.5	1.5	
			3.58 MHz		0.4	1.0	
I <sub>DD4</sub>	Run mode; V <sub>DD</sub> =3.0V± 10% 32 kHz Crystal oscillator			15.3	30	μA	
I <sub>DD5</sub>	Idle mode; V <sub>DD</sub> =3.0V± 10% 32 kHz Crystal oscillator			6.4	15		
I <sub>DD6</sub>	Stop mode; V <sub>DD</sub> =5.0V± 10%			2.5	5		
	V <sub>DD</sub> =3.0V± 10%			0.5	3		
Row Tone Level	V <sub>ROW</sub>	V <sub>DD</sub> = 5 V ± 10% V <sub>DD</sub> = 3 V ± 10% V <sub>DD</sub> = 2 V R <sub>L</sub> = 5kΩ	-16	-14	-11	dBV	
Ratio of Column to Row Tone	Db <sub>CR</sub>	V <sub>DD</sub> = 5 V ± 10% V <sub>DD</sub> = 3 V ± 10% V <sub>DD</sub> = 2 V R <sub>L</sub> = 5kΩ	1	2	3	dB	
Distortion (Dual tone)	THD	V <sub>DD</sub> = 5 V ± 10% V <sub>DD</sub> = 3 V ± 10% V <sub>DD</sub> = 2 V R <sub>L</sub> = 5kΩ, 1MHz band	-	-	5	%	

**NOTES:**

- D.C. electrical values for Supply Current (I<sub>DD1</sub> to I<sub>DD3</sub>) do not include current drawn through internal pull-up resistors.
- For D.C. electrical values, the power control register (PCON) must be set to 0011B.

Table 14-3. Main System Clock Oscillator Characteristics

(T<sub>A</sub> = -40 °C + 85 °C, V<sub>DD</sub> = 2.0 V to 5.5 V)

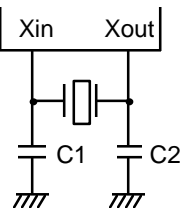
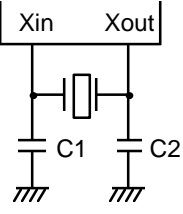
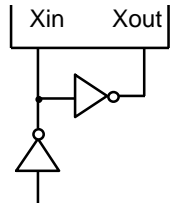
Oscillator	Clock Configuration	Parameter	Test Condition	Min	Typ	Max	Units
Ceramic Oscillator		Oscillation frequency (1)	V <sub>DD</sub> = 2.7 V to 5.5 V	0.4	–	6.0	MHz
			V <sub>DD</sub> = 2.0 V to 5.5 V	0.4	–	4.2	
		Stabilization time (2)	V <sub>DD</sub> = 3V	–	–	4	ms
Crystal Oscillator		Oscillation frequency (1)	V <sub>DD</sub> = 2.7 V to 5.5V	0.4	–	6.0	MHz
			V <sub>DD</sub> = 2.0 V to 5.5V	0.4	–	4.2	
		Stabilization time (2)	V <sub>DD</sub> = 3 V	–	–	10	ms
External Clock		X <sub>in</sub> input frequency (1)	V <sub>DD</sub> = 2.7 V to 5.5V	0.4	–	6.0	MHz
			V <sub>DD</sub> = 2.0 V to 5.5V	0.4	–	4.2	
		X <sub>in</sub> input high and low level width (t <sub>XH</sub> , t <sub>XL</sub> )	–	83.3	–	1250	ns

**NOTES:**

- Oscillation frequency and X<sub>in</sub> input frequency data are for oscillator characteristics only.
- Stabilization time is the interval required for oscillating stabilization after a power-on occurs, or when stop mode is terminated.

Table 14-4. Subsystem Clock Oscillator Characteristics

(T<sub>A</sub> = -40 °C + 85 °C, V<sub>DD</sub> = 2.0 V to 5.5 V)

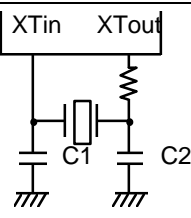
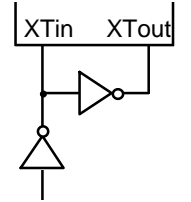
Oscillator	Clock Configuration	Parameter	Test Condition	Min	Typ	Max	Units
Crystal Oscillator		Oscillation frequency (1)	–	32	32.768	35	kHz
		Stabilization time (2)	V <sub>DD</sub> = 2.7V to 5.5V	–	1.0	2	s
			V <sub>DD</sub> = 2.0V to 5.5V	–	–	10	s
External Clock		XT <sub>in</sub> input frequency (1)	–	32	–	100	kHz
		XT <sub>in</sub> input high and low level width (t <sub>XH</sub> , t <sub>XL</sub> )	–	5	–	15	μs

**NOTES:**

- Oscillation frequency and XT<sub>in</sub> input frequency data are for oscillator characteristics only.
- Stabilization time is the interval required for oscillating stabilization after a power-on occurs or when stop mode is terminated.

Table 14-5. Input/Output Capacitance

(T<sub>A</sub> = 25 °C, V<sub>DD</sub> = 0 V)

Parameter	Symbol	Condition	Min	Typ	Max	Units
Input Capacitance	C <sub>IN</sub>	f = 1 MHz; Unmeasured pins are returned to V <sub>SS</sub>	–	–	15	pF
Output Capacitance	C <sub>OUT</sub>		–	–	15	pF
I/O Capacitance	C <sub>IO</sub>		–	–	15	pF

Table 14-6. A.C. Electrical Characteristics

(T<sub>A</sub> = -40 °C to +85 °C, V<sub>DD</sub> = 2.0 V to 5.5 V)

Parameter	Symbol	Conditions	Min	Typ	Max	Units
Instruction Cycle Time (1)	t <sub>CY</sub>	V <sub>DD</sub> = 2.7 V to 5.5 V	0.67	-	64	μs
		V <sub>DD</sub> = 2.0 V to 5.5 V	0.95			
TCL0, TCL1 Input Frequency	f <sub>TIO</sub> , f <sub>T11</sub>	V <sub>DD</sub> = 2.7 V to 5.5 V	0	-	1.5	MHz
		V <sub>DD</sub> = 2.0 V to 5.5 V			1	MHz
TCL0, TCL1 Input High, Low Width	t <sub>TIH0</sub> , t <sub>TIL0</sub> t <sub>TIH1</sub> , t <sub>TIL1</sub>	V <sub>DD</sub> = 2.7 V to 5.5 V	0.48	-	-	μs
		V <sub>DD</sub> = 2.0 V to 5.5 V	1.8			
SCK Cycle Time	t <sub>KCY</sub>	V <sub>DD</sub> = 2.7 V to 5.5 V External SCK source	800	-	-	ns
		Internal SCK source	670			
		V <sub>DD</sub> = 2.0 V to 5.5 V External SCK source	3200			
		Internal SCK source	3800			
SCK High, Low Width	t <sub>KH</sub> , t <sub>KL</sub>	V <sub>DD</sub> = 2.7 V to 5.5 V External SCK source	335	-	-	ns
		Internal SCK source	t <sub>KCY</sub> -250			
		V <sub>DD</sub> = 2.0 V to 5.5 V External SCK source	1600			
		Internal SCK source	t <sub>KCY</sub> - 2150			
SI Setup Time to SCK High	t <sub>SIK</sub>	V <sub>DD</sub> = 2.7 V to 5.5 V External SCK source	100	-	-	ns
		Internal SCK source	150			
		V <sub>DD</sub> = 2.0 V to 5.5 V External SCK source	150			
		Internal SCK source	500			
SI Hold Time to SCK High	t <sub>KSI</sub>	V <sub>DD</sub> = 2.7 V to 5.5 V External SCK source	400	-	-	ns
		Internal SCK source	400			
		V <sub>DD</sub> = 2.0 V to 5.5 V External SCK source	600			
		Internal SCK source	500			

Table 14-6. A.C. Electrical Characteristics (Continued)

(T<sub>A</sub> = -40 °C to +85 °C, V<sub>DD</sub> = 2.0 V to 5.5 V)

Parameter	Symbol	Conditions	Min	Typ	Max	Units
Output Delay for SCK to SO	t <sub>KSO</sub> (NOTE)	V <sub>DD</sub> = 2.7 V to 5.5 V External SCK source	-	-	300	ns
		Internal SCK source			250	
		V <sub>DD</sub> = 2.0 V to 5.5 V External SCK source			1000	
		Internal SCK source			1000	
Interrupt Input High, Low Width	t <sub>INTH</sub> , t <sub>INTL</sub>	INT0, INT1, INT2, INT4, KS0-KS7	10	-	-	μs
RESET Input Low Width	t <sub>RSL</sub>	Input	10	-	-	μs

**NOTE:** R (1 kΩ) and C (100 pF) are the load resistance and load capacitance of the SO output line.

Figure 14-1. Standard Operating Voltage Range



Table 14-7. RAM Data Retention Supply Voltage in Stop Mode

(T<sub>A</sub> = -40 °C to + 85 °C)

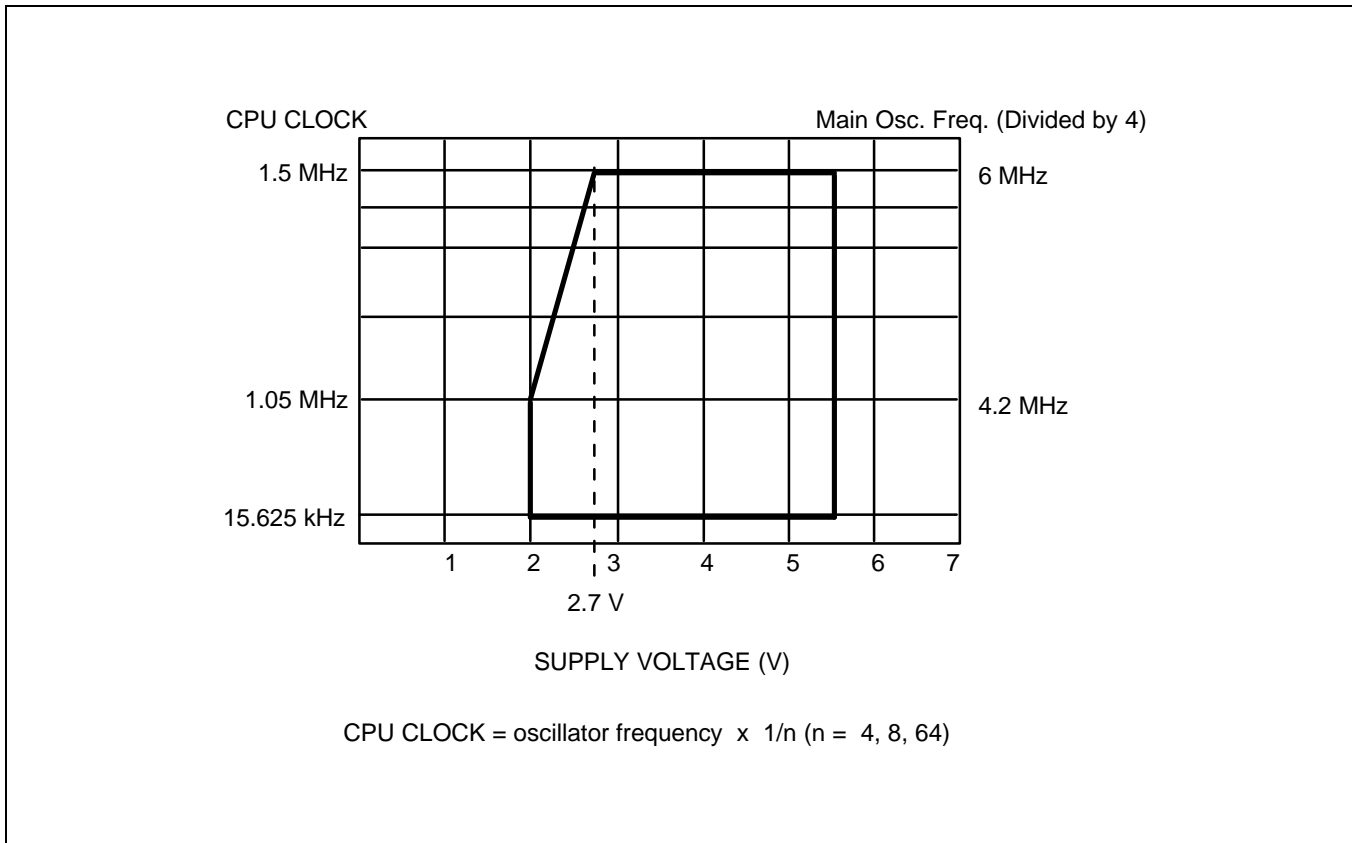
Parameter	Symbol	Conditions	Min	Typ	Max	Unit
Data retention supply voltage	V <sub>DDDR</sub>	–	1.5	–	5.5	V
Data retention supply current	I <sub>DDDR</sub>	V <sub>DDDR</sub> = 1.5 V	–	0.1	10	μA
Release signal set time	t <sub>SREL</sub>	–	0	–	–	μs
Oscillator stabilization wait time (1)	t <sub>WAIT</sub>	Released by RESET	–	2 <sup>17</sup> / f <sub>x</sub>	–	ms
		Released by interrupt	–	(2)	–	ms

**NOTES:**

1. During oscillator stabilization wait time, all CPU operations must be stopped to avoid instability during oscillator start-up.
2. Use the basic timer mode register (BMOD) interval timer to delay execution of CPU instructions during the wait time.

TIMING WAVEFORMS

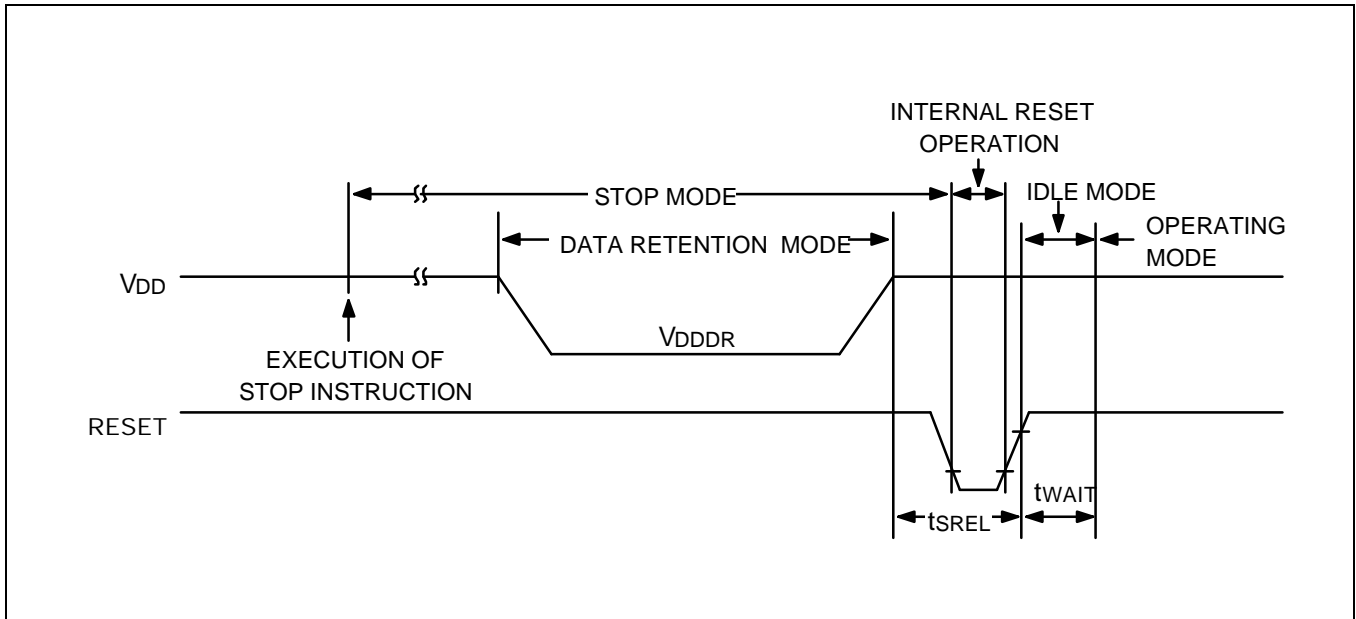

Figure 14-2. Stop Mode Release Timing When Initiated By RESET

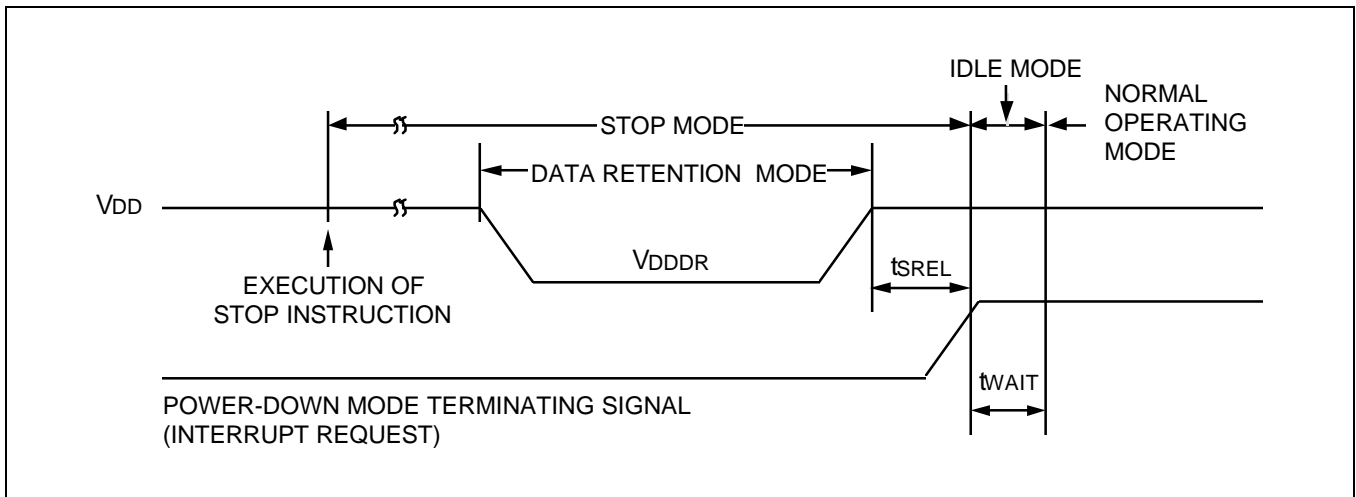

Figure 14-3. Stop Mode Release Timing When Initiated By Interrupt Request

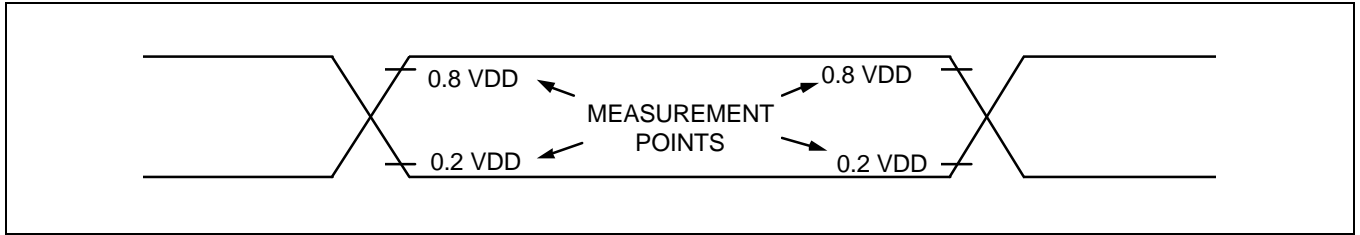

Figure 14-4. A.C. Timing Measurement Points (Except for  $X_{in}$  and  $XT_{in}$ )

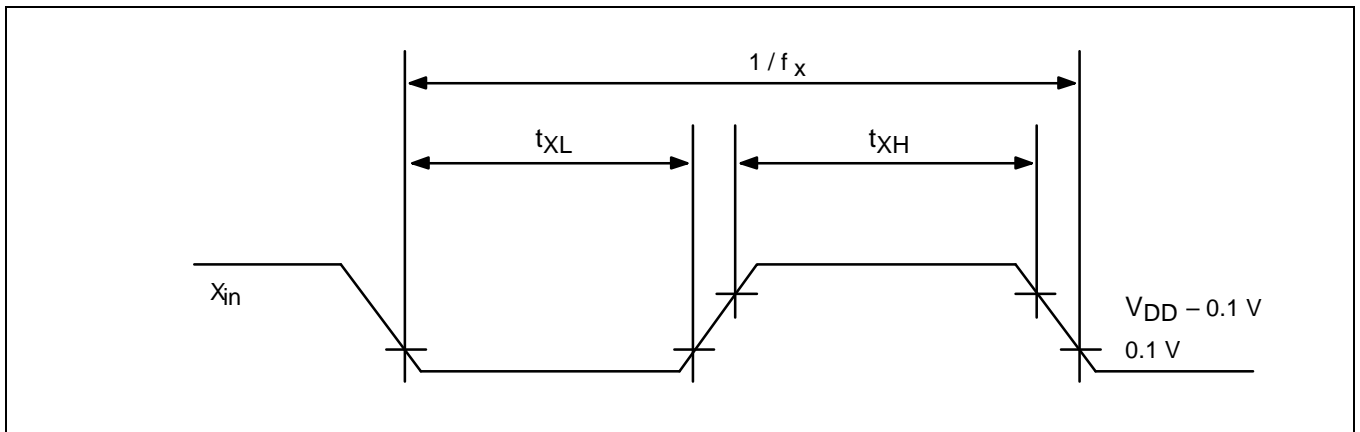

Figure 14-5. Clock Timing Measurement at  $X_{in}$  ( $XT_{in}$ )

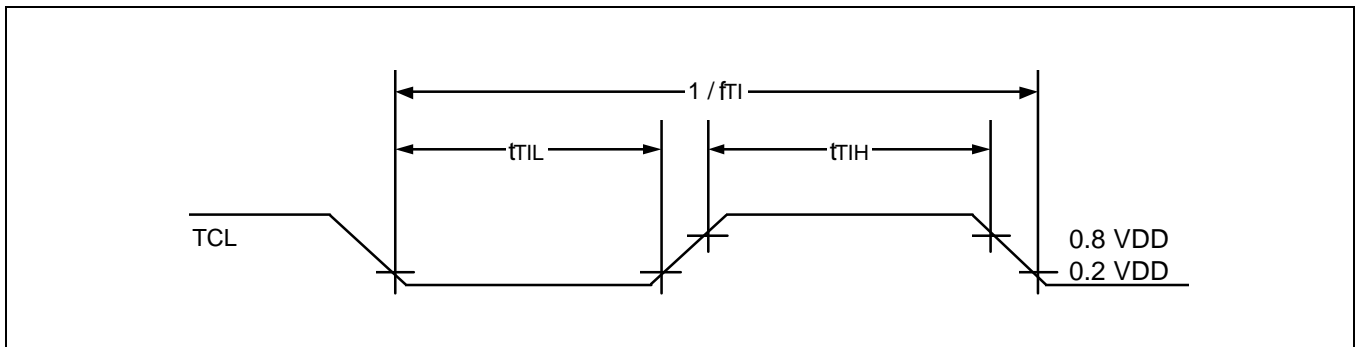

Figure 14-6. TCL0/1 Timing

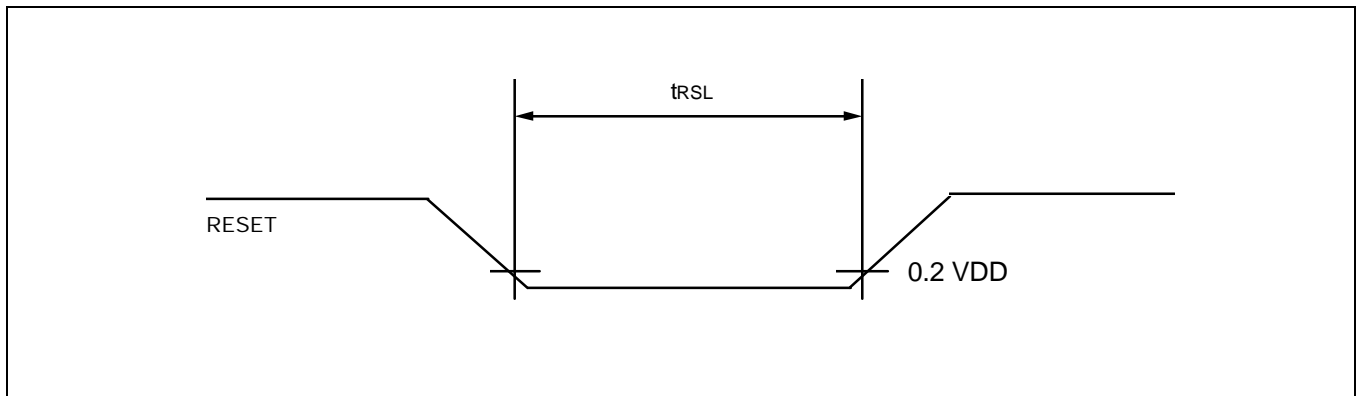

Figure 14-7. Input Timing for RESET Signal

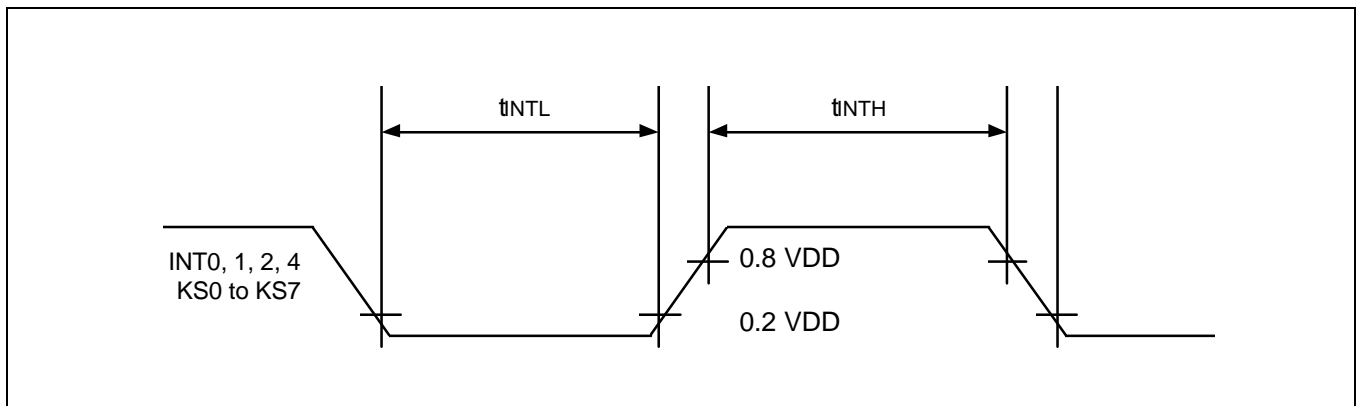

Figure 14-8. Input Timing for External Interrupts and Quasi-Interrupts

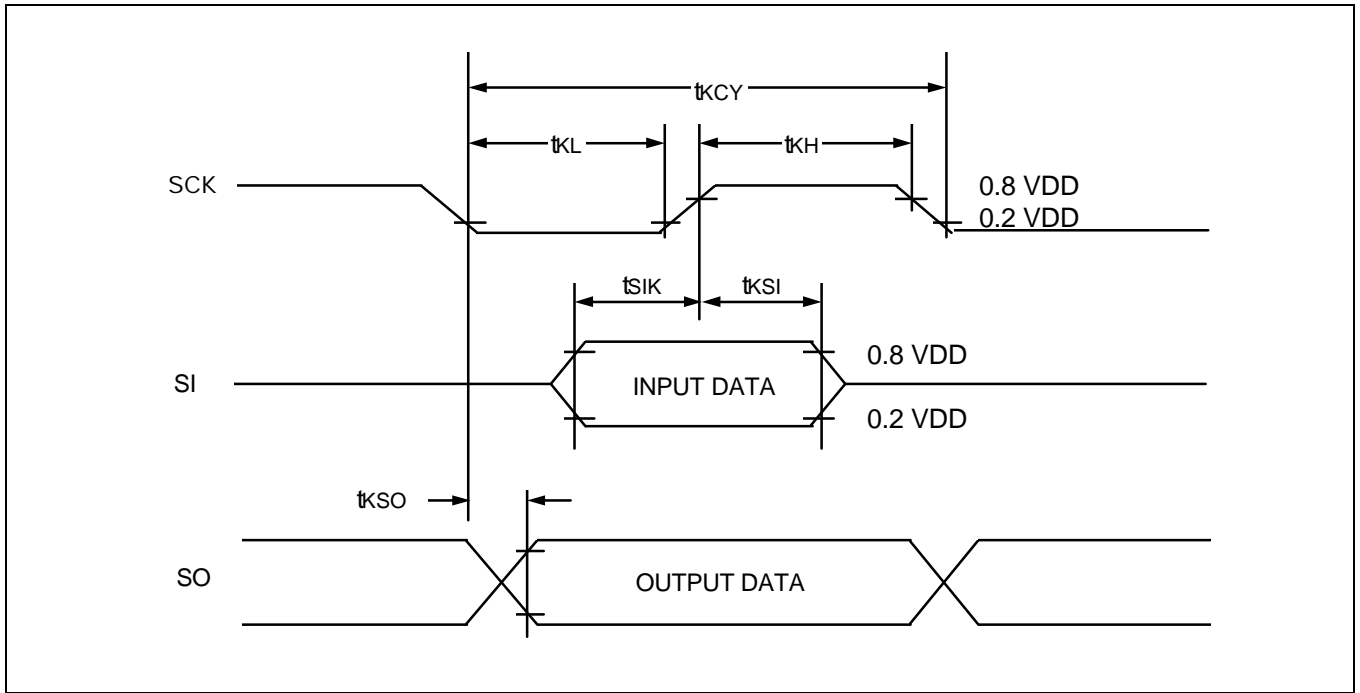

Figure 14-9. Serial Data Transfer Timing

CHARACTERISTIC CURVES

NOTE

The characteristic values shown in the following graphs are based on actual test measurements. They do not, however, represent guaranteed operating values.

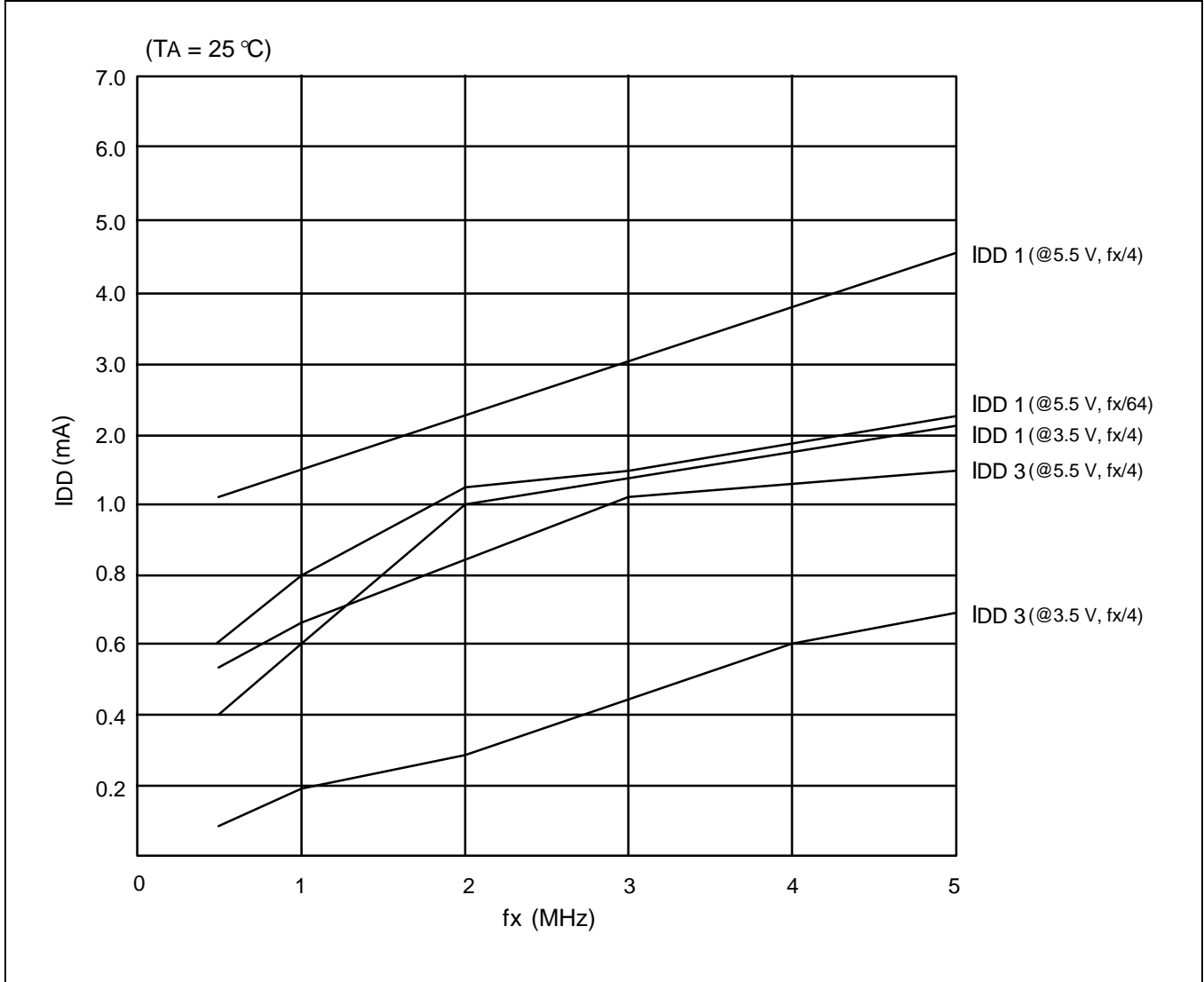

Figure 14-10. IDD VS. Frequency

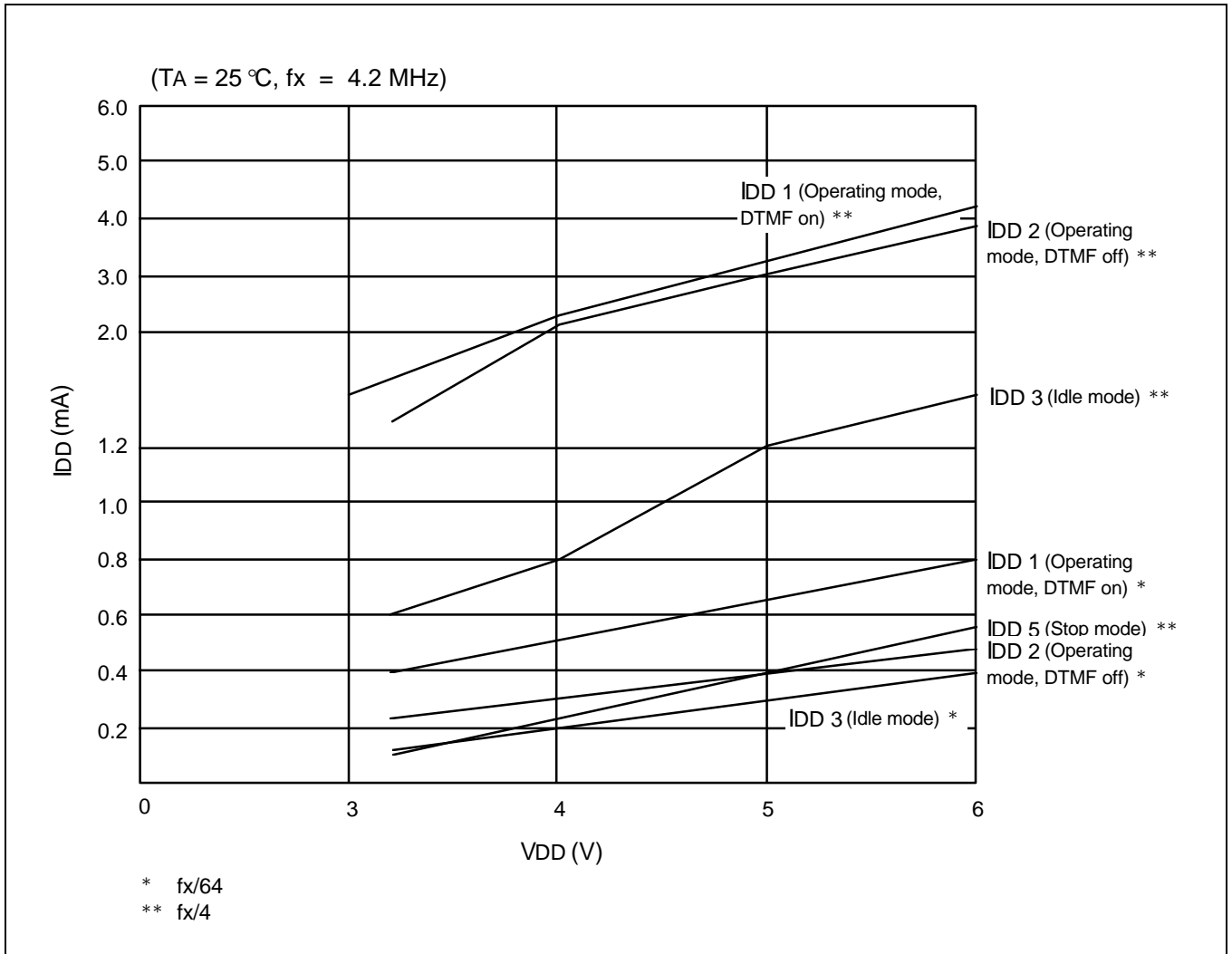

Figure 14-11. IDD VS. VDD

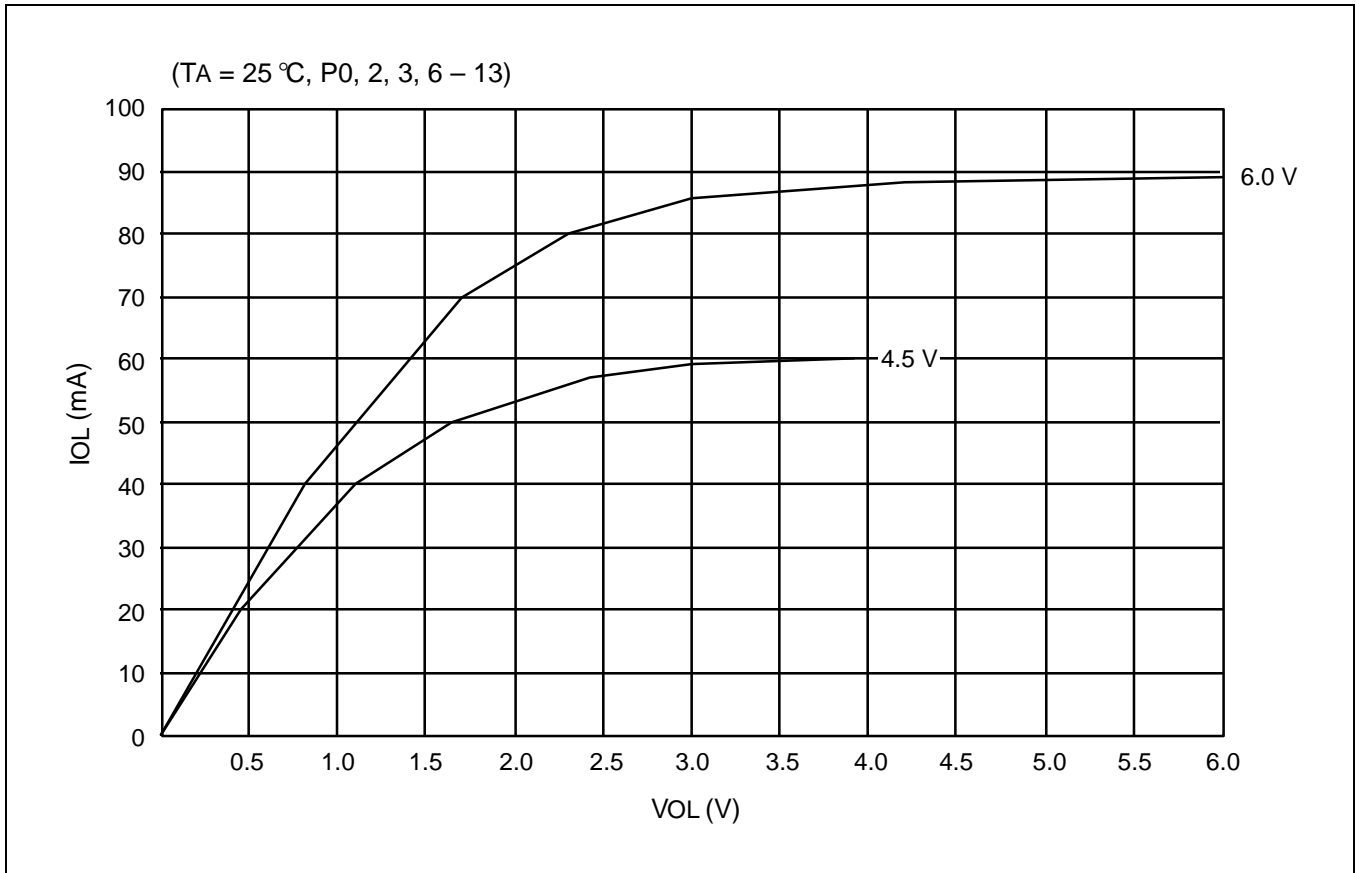

Figure 14-12. IOL VS. VOL (P0, 2, 3, and 6–13)

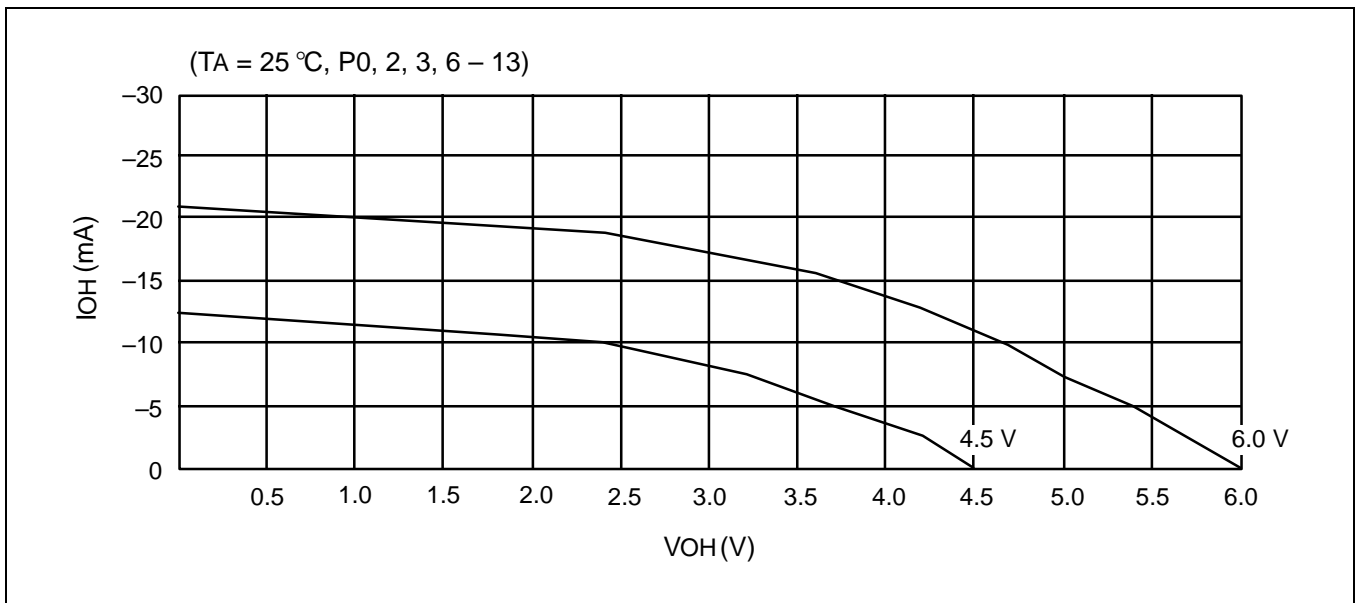

Figure 14-13. IOH VS. VOH (P0, 2, 3, and 6–13)



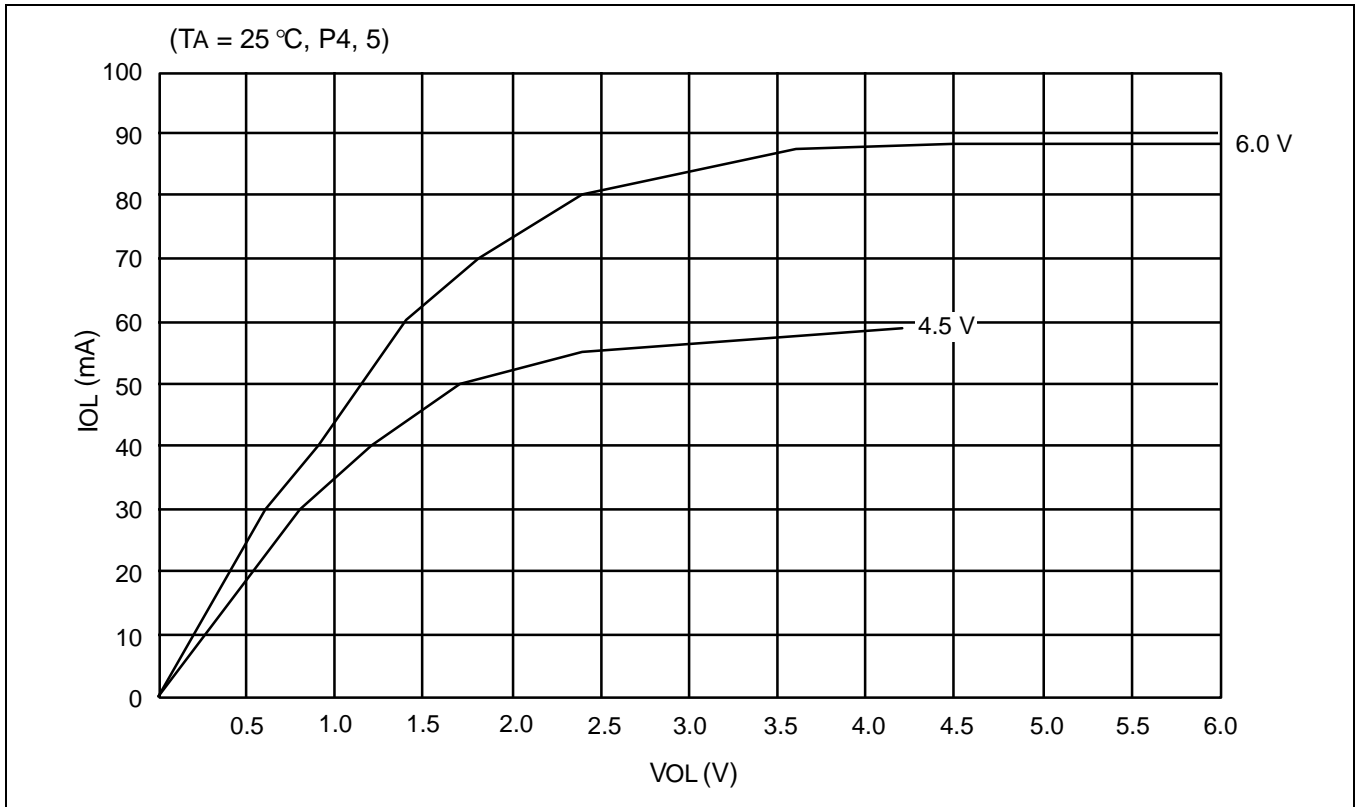

Figure 14-14. IOL VS. VOL (P4 and 5)

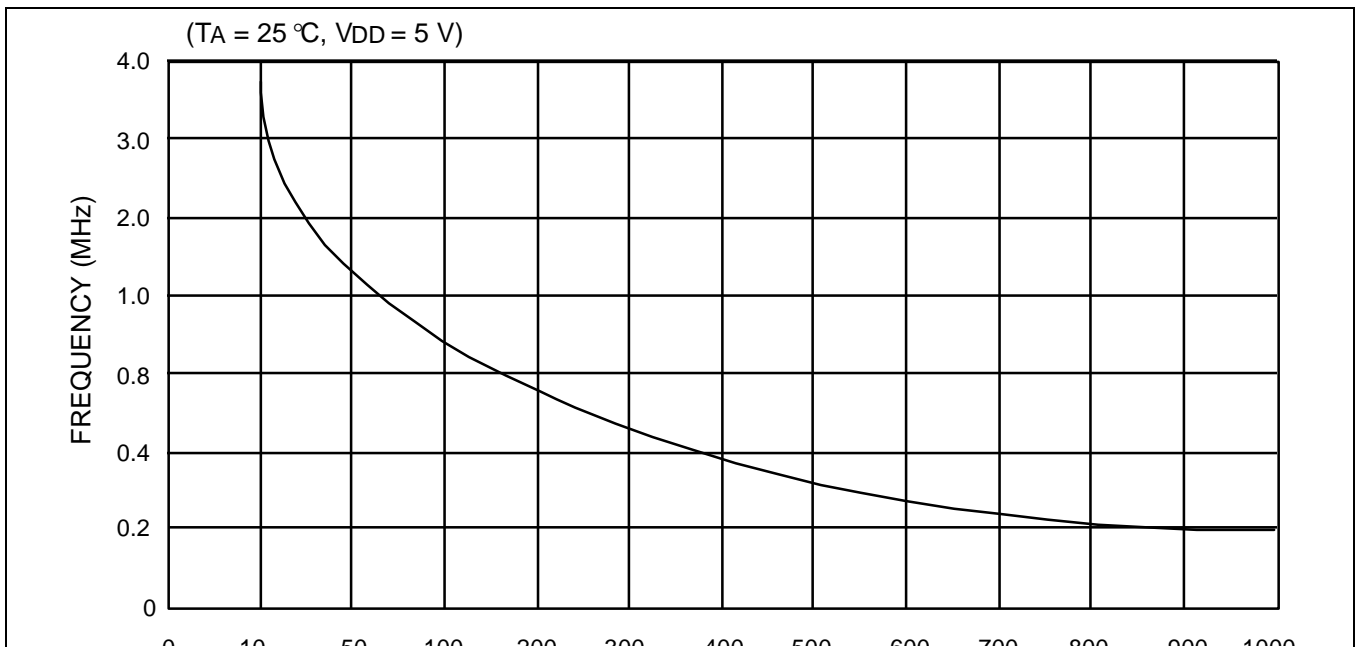

Figure 14-16. Frequency VS. Resistor

# 15 MECHANICAL DATA

This section contains the following information about the device package:

- Package dimensions in millimeters
- Pad diagram
- Pad/pin coordinate data table

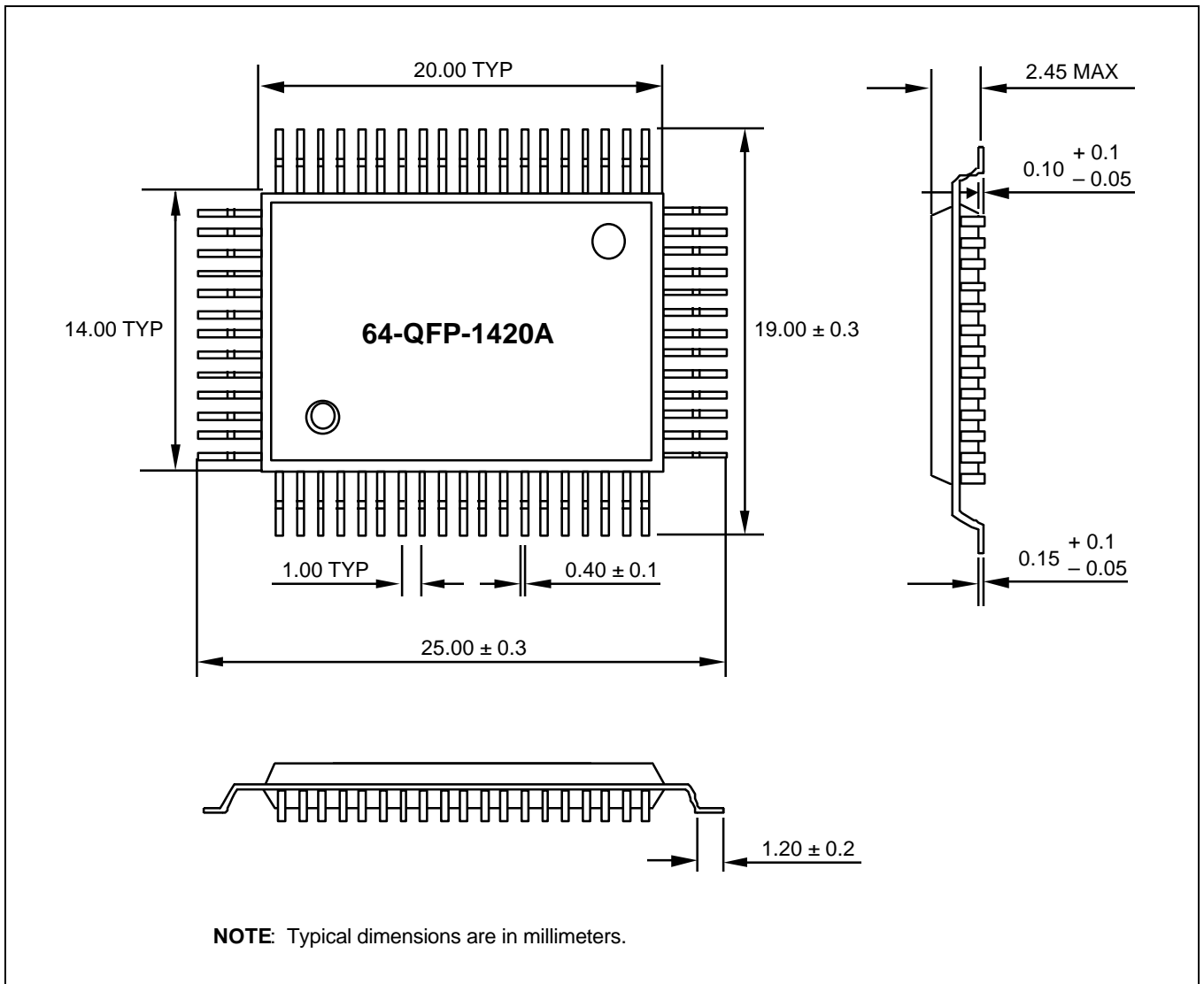

Figure 15-1. 64-QFP-1420A Package Dimensions

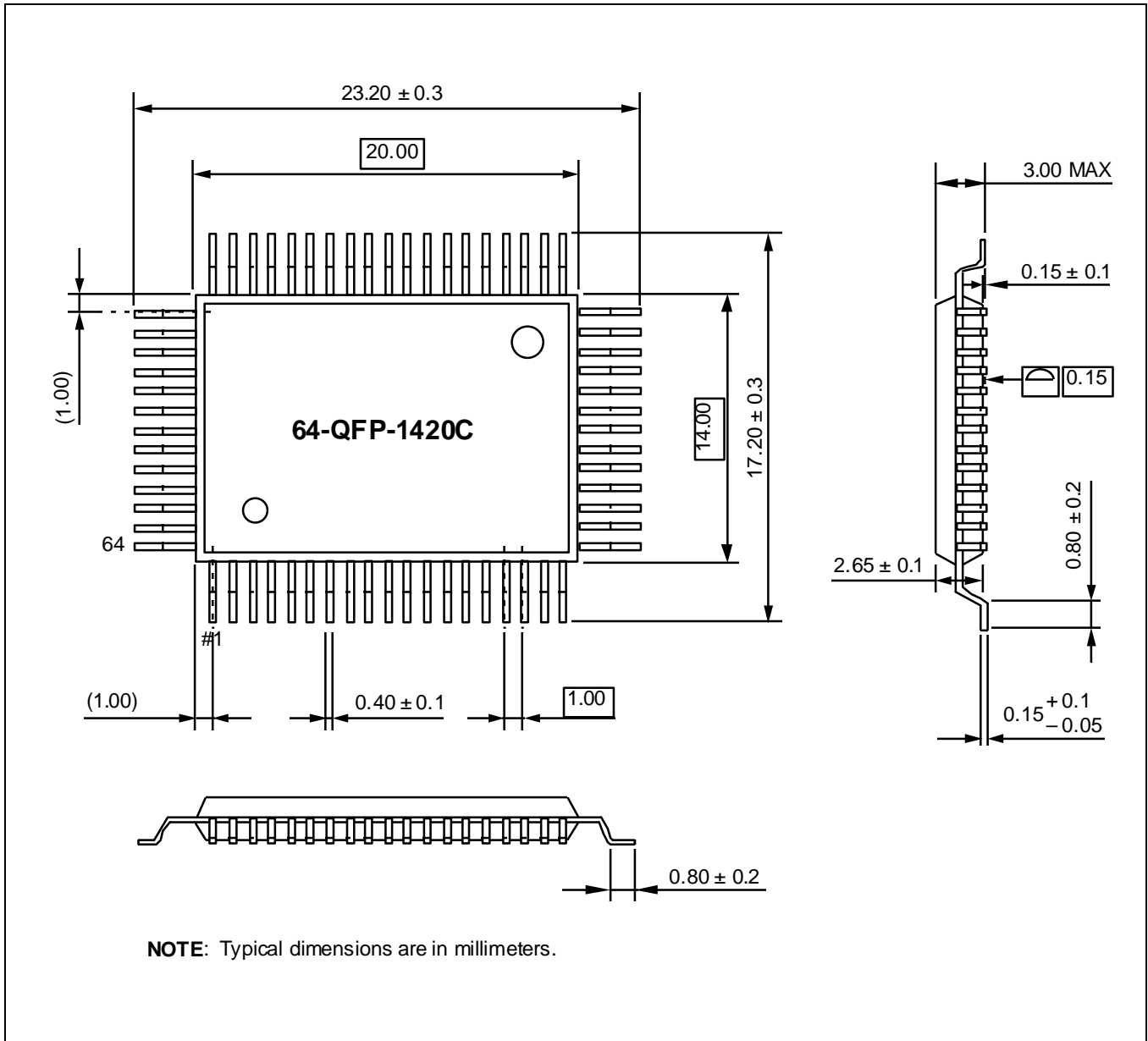

Figure 15-2 64-QFP-1420C Package Dimensions

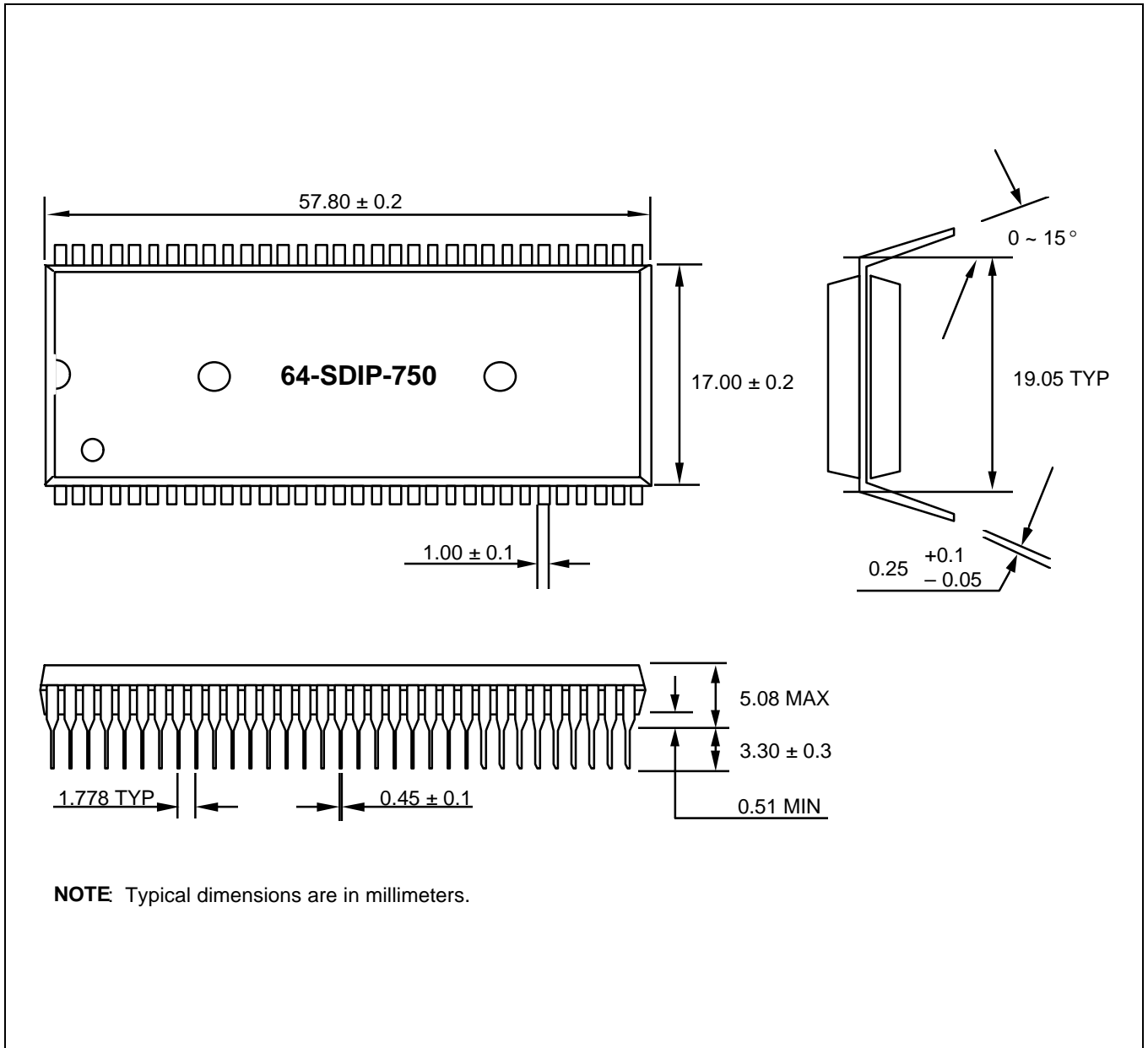

Figure 15-3. 64-SDIP-750 Package Dimensions

# 16

## S3P7515 OTP

### OVERVIEW

The S3P7515 single-chip CMOS microcontroller is the OTP (One Time Programmable) version of the S3C7515 microcontroller. It has an on-chip OTP ROM instead of masked ROM. The EPROM is accessed by serial data format.

The S3P7515 is fully compatible with the S3C7515, both in function and in pin configuration. Because of its simple programming requirements, the S3P7515 is ideal for use as an evaluation chip for the S3C7515.

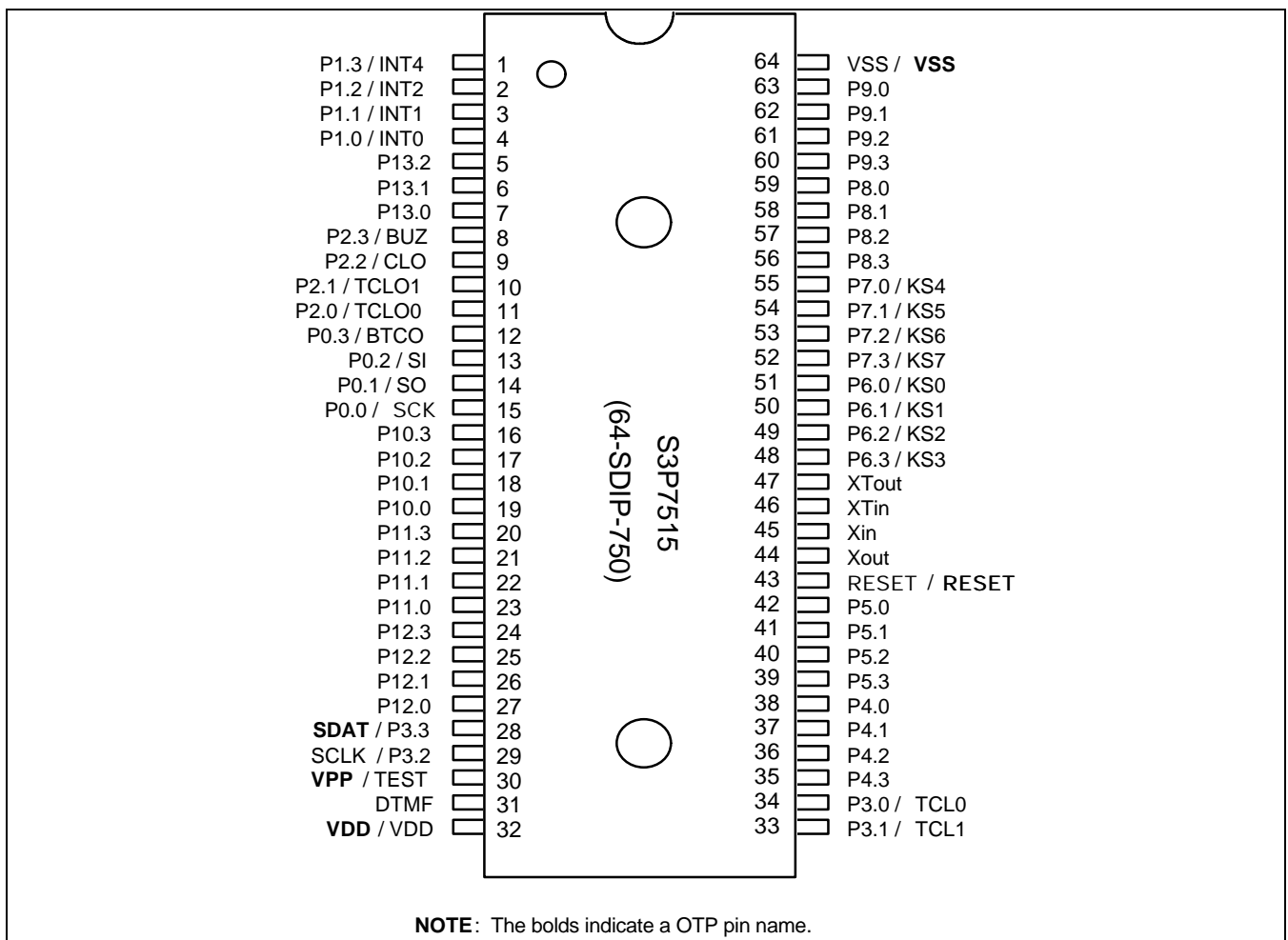

Figure 16-1. S3P7515 Pin Assignments (64-SDIP)

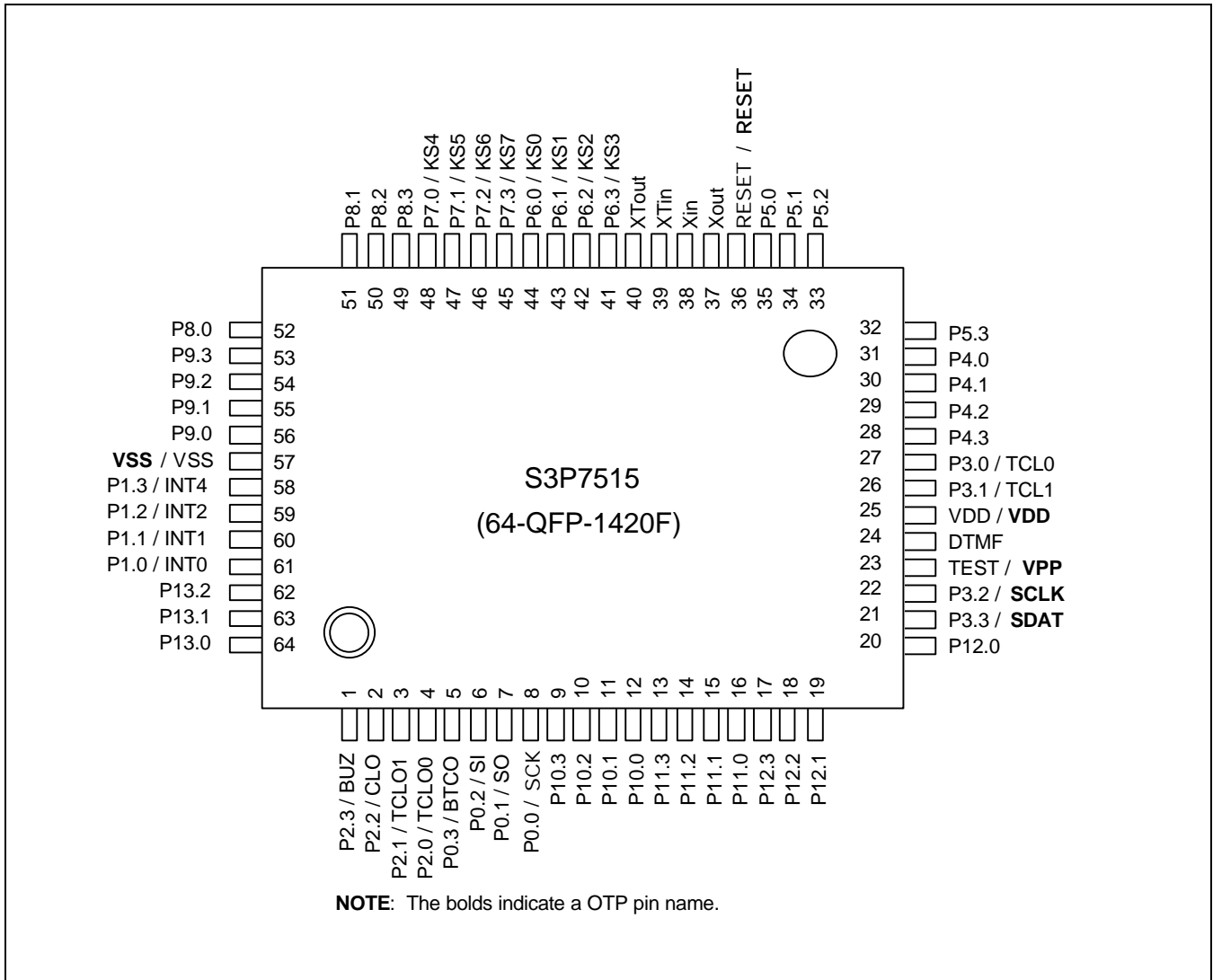

Figure 16-2. S3P7515 Pin Assignments (64-QFP)

Table 16-1. Descriptions of Pins Used to Read/Write the EPROM

Pin Name	During Programming		
	Pin No.	I/O	Function
SDAT	28 (21)	I/O	Serial data pin. Output port when reading and input port when writing. Can be assigned as a Input / push-pull output port.
SCLK	29 (22)	I	Serial clock pin. Input only pin.
V <sub>pp</sub> (TEST)	30 (23)	I	Power supply pin for EPROM cell writing (indicates that OTP enters into the writing mode). When 12.5 V is applied, OTP is in writing mode and when 5 V is applied, OTP is in reading mode. (Option)
RESET	43 (36)	I	Chip initialization
V <sub>DD</sub> / V <sub>SS</sub>	32 (25) / 64 (57)	I	Logic power supply pin. V <sub>DD</sub> should be tied to +5 V during programming.

**NOTE:** Parentheses indicate pin number for 64 QFP package.

Table 16-2. Comparison of S3P7515 and S3C7515 Features

Characteristic	S3P7515	S3C7515
Program Memory	16 K byte EPROM	2 K byte mask ROM
Operating Voltage (V <sub>DD</sub> )	2.0 V to 5.5 V	2.0 V to 5.5 V
OTP Programming Mode	V <sub>DD</sub> = 5 V, V <sub>PP</sub> (TEST)=12.5V	
Pin Configuration	64SDIP / QFP	64SDIP / QFP
EPROM Programmability	User Program 1 time	Programmed at the factory

## OPERATING MODE CHARACTERISTICS

When 12.5 V is supplied to the V<sub>PP</sub>(TEST) pin of the S3P7515, the EPROM programming mode is entered. The operating mode (read, write, or read protection) is selected according to the input signals to the pins listed in Table 14-3 below.

Table 16-3. Operating Mode Selection Criteria

V <sub>DD</sub>	V <sub>pp</sub> (TEST)	REG/ MEM	Address (A15-A0)	R/W	Mode
5 V	5 V	0	0000H	1	EPROM read
	12.5V	0	0000H	0	EPROM program
	12.5V	0	0000H	1	EPROM verify
	12.5V	1	0E3FH	0	EPROM read protection

**NOTE:** "0" means Low level; "1" means High level.

Table 16-4. D.C. Electrical Characteristics

(T<sub>A</sub> = -40°C to +85°C, V<sub>DD</sub> = 2.0 V to 5.5 V)

Parameter	Symbol	Conditions	Min	Typ	Max	Units
Supply Current (1,2)	I <sub>DD1</sub> (DTMF ON)	Run mode; V <sub>DD</sub> = 5.0V ± 10% 3.58MHz Crystal oscillator; C1=C2=22pF	-	2.2	5.0	mA
		V <sub>DD</sub> = 3 V ± 10%		1.2	3.0	
	I <sub>DD2</sub> (DTMF OFF)	Run mode; V <sub>DD</sub> = 5.0V ± 10% Crystal oscillator; C1=C2=22pF	6.0 MHz		3.9	8.0
			3.58 MHz		2.0	4.0
		V <sub>DD</sub> = 3 V ± 10%	6.0 MHz		1.8	4.0
			3.58 MHz		0.8	2.3
	I <sub>DD3</sub>	Idle mode; V <sub>DD</sub> = 5 V ± 10%	6.0 MHz		1.3	2.5
			3.58 MHz		0.6	1.8
		V <sub>DD</sub> = 3 V ± 10%	6.0 MHz		0.5	1.5
			3.58 MHz		0.4	1.0
	I <sub>DD4</sub>	Run mode; V <sub>DD</sub> = 3.0V ± 10% 32 kHz Crystal oscillator		15.3	30	μA
	I <sub>DD5</sub>	Idle mode; V <sub>DD</sub> = 3.0V ± 10% 32 kHz Crystal oscillator		6.4	15	
I <sub>DD6</sub>	Stop mode; V <sub>DD</sub> = 5.0V ± 10%		2.5	5		
	V <sub>DD</sub> = 3.0V ± 10%		0.5	3		

**NOTES:**

- D.C. electrical values for Supply Current (I<sub>DD1</sub> to I<sub>DD3</sub>) do not include current drawn through internal pull-up resistors.
- For D.C. electrical values, the power control register (PCON) must be set to 0011B.



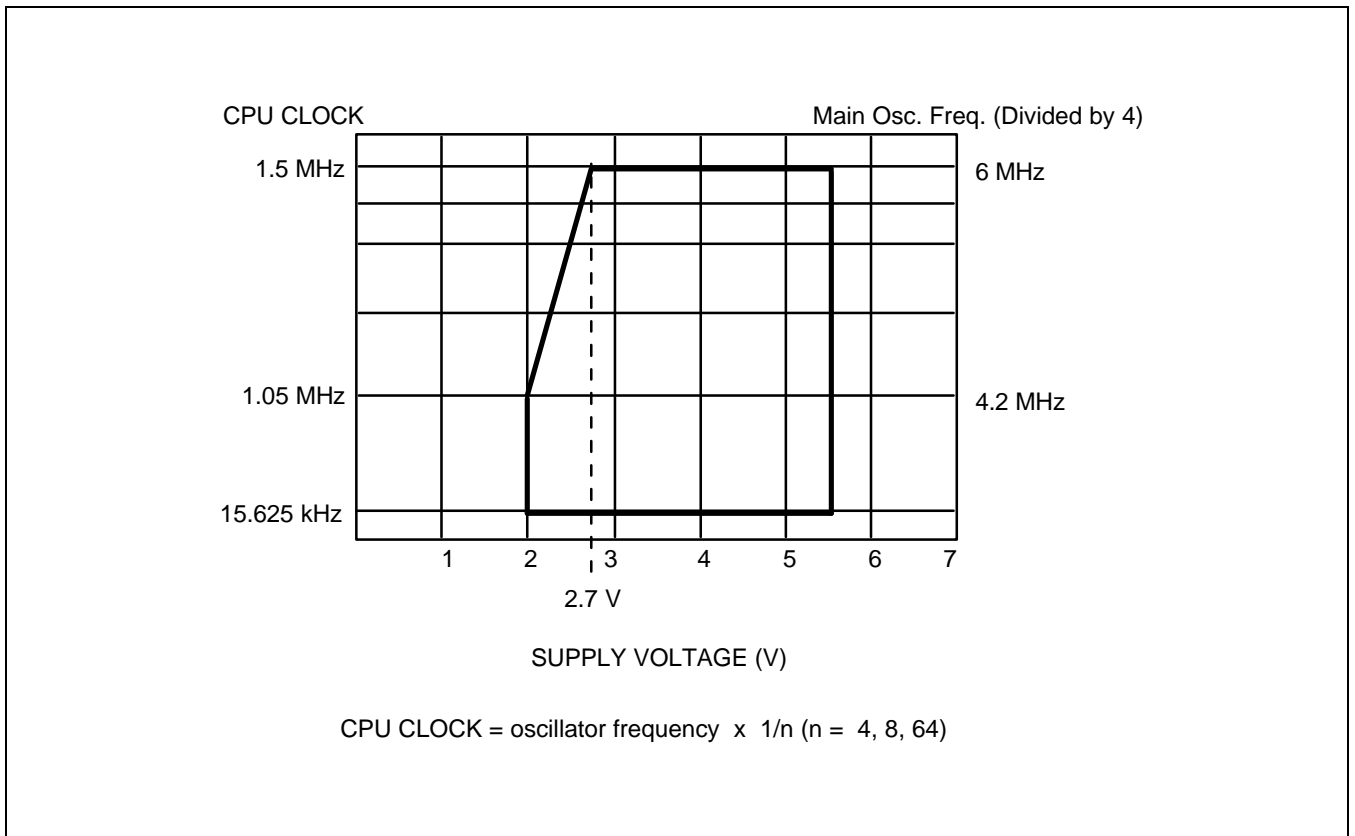

Figure 16-3. Standard Operating Voltage Range

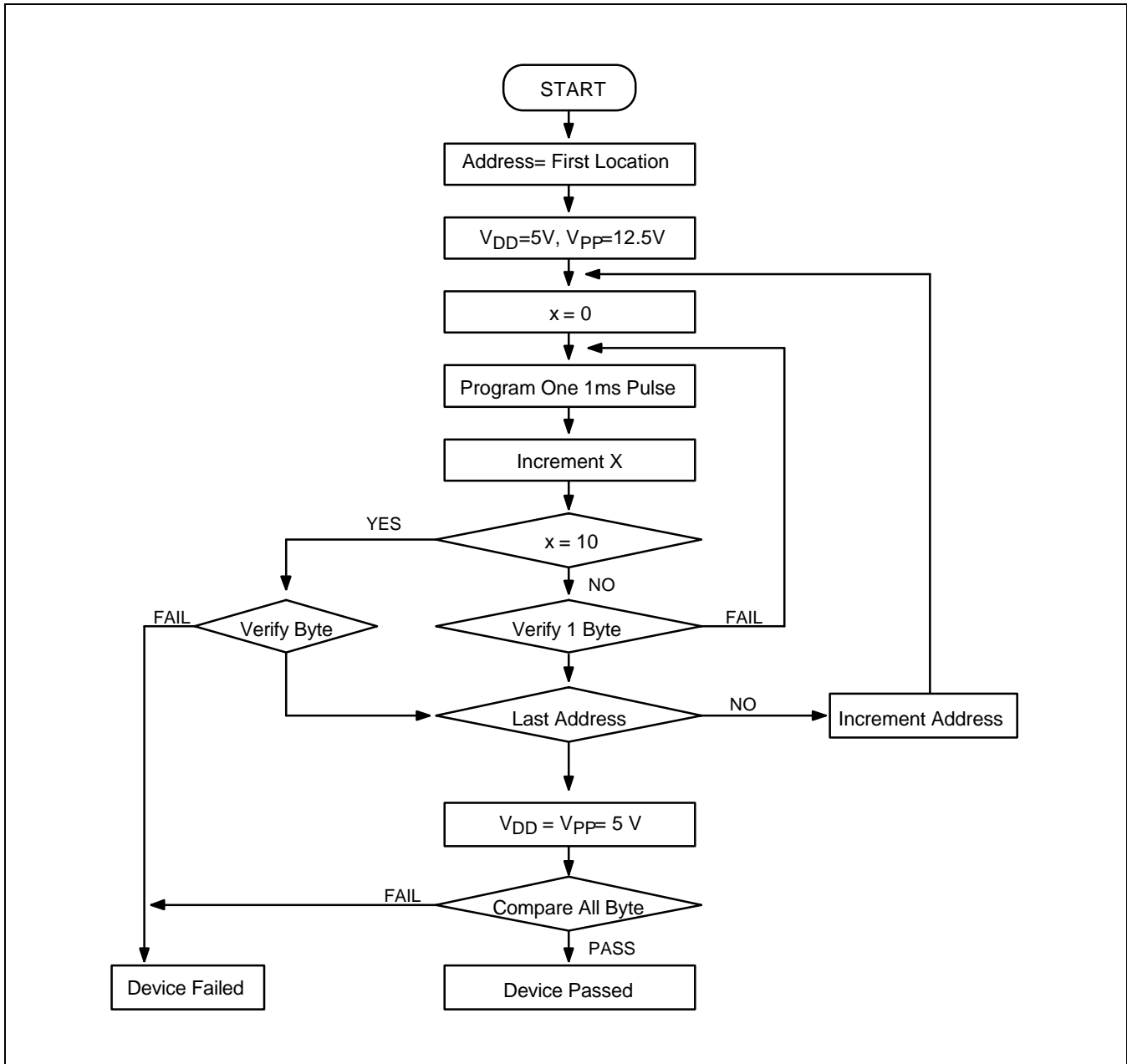

Figure 16-4. OTP Programming Algorithm