

S3C84H5/F84H5

8-BIT CMOS MICROCONTROLLERS USER'S MANUAL

Revision 1



ELECTRONICS

Important Notice

The information in this publication has been carefully checked and is believed to be entirely accurate at the time of publication. Samsung assumes no responsibility, however, for possible errors or omissions, or for any consequences resulting from the use of the information contained herein.

Samsung reserves the right to make changes in its products or product specifications with the intent to improve function or design at any time and without notice and is not required to update this documentation to reflect such changes.

This publication does not convey to a purchaser of semiconductor devices described herein any license under the patent rights of Samsung or others.

Samsung makes no warranty, representation, or guarantee regarding the suitability of its products for any particular purpose, nor does Samsung assume any liability arising out of the application or use of any product or circuit and specifically disclaims any and all liability, including without limitation any consequential or incidental damages.

S3C84H5/F84H5 8-Bit CMOS Microcontrollers
User's Manual, Revision 1
Publication Number: 21-S3-C84H5/F84H5-012006

© 2006 Samsung Electronics

All rights reserved. No part of this publication may be reproduced, stored in a retrieval system, or transmitted in any form or by any means, electric or mechanical, by photocopying, recording, or otherwise, without the prior written consent of Samsung Electronics.

Samsung Electronics' microcontroller business has been awarded full ISO-14001 certification (BSI Certificate No. FM24653). All semiconductor products are designed and manufactured in accordance with the highest quality standards and objectives.

Samsung Electronics Co., Ltd.
San #24 Nongseo-Ri, Giheung-Eup
Yongin-City, Gyeonggi-Do, Korea
C.P.O. Box #37, Suwon 440-900

TEL: (82)-(31)-209-5238
FAX: (82)-(31)-209-6494
Home Page: <http://www.samsung.com>

Printed in the Republic of Korea

"Typical" parameters can and do vary in different applications. All operating parameters, including "Typicals" must be validated for each customer application by the customer's technical experts.

Samsung products are not designed, intended, or authorized for use as components in systems intended for surgical implant into the body, for other applications intended to support or sustain life, or for any other application in which the failure of the Samsung product could create a situation where personal injury or death may occur.

Should the Buyer purchase or use a Samsung product for any such unintended or unauthorized application, the Buyer shall indemnify and hold Samsung and its officers, employees, subsidiaries, affiliates, and distributors harmless against all claims, costs, damages, expenses, and reasonable attorney fees arising out of, either directly or indirectly, any claim of personal injury or death that may be associated with such unintended or unauthorized use, even if such claim alleges that Samsung was negligent regarding the design or manufacture of said product.

Preface

The S3C84H5/F84H5 *Microcontroller User's Manual* is designed for application designers and programmers who are using the S3C84H5/F84H5 microcontroller for application development. It is organized in two main parts:

Part I Programming Model

Part II Hardware Descriptions

Part I contains software-related information to familiarize you with the microcontroller's architecture, programming model, instruction set, and interrupt structure. It has six chapters:

Chapter 1	Product Overview	Chapter 4	Control Registers
Chapter 2	Address Spaces	Chapter 5	Interrupt Structure
Chapter 3	Addressing Modes	Chapter 6	Instruction Set

Chapter 1, "Product Overview," is a high-level introduction to S3C84H5/F84H5 with general product descriptions, as well as detailed information about individual pin characteristics and pin circuit types.

Chapter 2, "Address Spaces," describes program and data memory spaces, the internal register file, and register addressing. Chapter 2 also describes working register addressing, as well as system stack and user-defined stack operations.

Chapter 3, "Addressing Modes," contains detailed descriptions of the addressing modes that are supported by the S3C8-series CPU.

Chapter 4, "Control Registers," contains overview tables for all mapped system and peripheral control register values, as well as detailed one-page descriptions in a standardized format. You can use these easy-to-read, alphabetically organized, register descriptions as a quick-reference source when writing programs.

Chapter 5, "Interrupt Structure," describes the S3C84H5/F84H5 interrupt structure in detail and further prepares you for additional information presented in the individual hardware module descriptions in Part II.

Chapter 6, "Instruction Set," describes the features and conventions of the instruction set used for all S3C8-series microcontrollers. Several summary tables are presented for orientation and reference. Detailed descriptions of each instruction are presented in a standard format. Each instruction description includes one or more practical examples of how to use the instruction when writing an application program.

A basic familiarity with the information in Part I will help you to understand the hardware module descriptions in Part II. If you are not yet familiar with the S3C8-series microcontroller family and are reading this manual for the first time, we recommend that you first read Chapters 1–3 carefully. Then, briefly look over the detailed information in Chapters 4, 5, and 6. Later, you can reference the information in Part I as necessary.

Part II "hardware Descriptions," has detailed information about specific hardware components of the S3C84H5/F84H5 microcontroller. Also included in Part II are electrical, mechanical, OTP, and development tools data. It has 17 chapters:

Chapter 7	Clock Circuit	Chapter 16	A/D Converter
Chapter 8	RESET and Power-Down	Chapter 17	Watch Timer
Chapter 9	I/O Ports	Chapter 18	LCD Controller/Driver
Chapter 10	Basic Timer	Chapter 19	Low Voltage RESET
Chapter 11	8-bit Timer A/B	Chapter 20	Embedded Flash Memory Interface
Chapter 12	16-bit Timer 1(0,1)	Chapter 21	Electrical Data
Chapter 13	10-bit PWM (pulse width modulation)	Chapter 22	Mechanical Data
Chapter 14	Serial I/O Interface	Chapter 23	Development Tools
Chapter 15	UART		

Two order forms are included at the back of this manual to facilitate customer order for S3C84H5/F84H5 microcontrollers: the Mask ROM Order Form, and the Mask Option Selection Form. You can photocopy these forms, fill them out, and then forward them to your local Samsung Sales Representative.

Table of Contents

Part I — Programming Model

Chapter 1 Product Overview

S3C8-Series Microcontrollers	1-1
S3C84H5/F84H5 Microcontroller	1-1
Features	1-2
Block Diagram	1-3
Pin Assignment	1-4
Pin Assignment	1-5
Pin Assignment	1-6
Pin Descriptions	1-7
Pin Circuits	1-11

Chapter 2 Address Spaces

Overview	2-1
Program Memory (ROM)	2-2
Register Architecture	2-4
Register Page Pointer (PP)	2-6
Register Set 1	2-8
Register Set 2	2-8
Prime Register Space	2-9
Working Registers	2-10
Using the Register Pointers	2-11
Register Addressing	2-13
Common Working Register Area (C0H–CFH)	2-15
4-Bit Working Register Addressing	2-16
8-Bit Working Register Addressing	2-18
System and User Stack	2-20

Chapter 3 Addressing Modes

Overview	3-1
Register Addressing Mode (R)	3-2
Indirect Register Addressing Mode (IR)	3-3
Indexed Addressing Mode (X)	3-7
Direct Address Mode (DA)	3-10
Indirect Address Mode (IA)	3-12
Relative Address Mode (RA)	3-13
Immediate Mode (IM)	3-14

Table of Contents (Continued)

Chapter 4 Control Registers

Overview.....	4-1
---------------	-----

Chapter 5 Interrupt Structure

Overview.....	5-1
Interrupt Types.....	5-2
S3C84H5/F84H5 Interrupt Structure.....	5-3
Interrupt Vector Addresses.....	5-5
Enable/Disable Interrupt Instructions (EI, DI).....	5-7
System-Level Interrupt Control Registers.....	5-7
Interrupt Processing Control Points.....	5-8
Peripheral Interrupt Control Registers.....	5-9
System Mode Register (SYM).....	5-10
Interrupt Mask Register (IMR).....	5-11
Interrupt Priority Register (IPR).....	5-12
Interrupt Request Register (IRQ).....	5-14
Interrupt Pending Function Types.....	5-15
Interrupt Source Polling Sequence.....	5-16
Interrupt Service Routines.....	5-16
Generating interrupt Vector Addresses.....	5-17
Nesting of Vectored Interrupts.....	5-17

Chapter 6 Instruction Set

Overview.....	6-1
Data Types.....	6-1
Register Addressing.....	6-1
Addressing Modes.....	6-1
Flags Register (FLAGS).....	6-6
Flag Descriptions.....	6-7
Instruction Set Notation.....	6-8
Condition Codes.....	6-12
Instruction Descriptions.....	6-13

Table of Contents (Continued)

Part II Hardware Descriptions

Chapter 7 Clock Circuit

Overview	7-1
System clock Circuit	7-1
Clock Status During Power-Down Modes	7-2
System Clock Control Register (CLKCON)	7-3

Chapter 8 RESET and Power-Down

System Reset	8-1
Overview	8-1
Normal Mode Reset Operation	8-1
Hardware Reset Values	8-2
Power-Down Modes	8-5
Stop Mode	8-5
Idle Mode	8-6

Chapter 9 I/O Ports

Overview	9-1
Port Data Registers	9-2
Port 0	9-3
Port 1	9-4
Port 2	9-8
Port 3	9-12

Chapter 10 Basic Timer

Overview	10-1
Basic Timer (BT)	10-1
Basic Timer Control Register (BTCN)	10-1
Basic Timer Function Description	10-3

Table of Contents (Continued)

Chapter 11 8-Bit Timer A/B

8-Bit Timer A.....	11-1
Overview	11-1
Function Description	11-2
Timer A Control Register (TACON)	11-3
Block Diagram.....	11-4
8-Bit Timer B.....	11-5
Overview	11-5
Block Diagram.....	11-5
Timer B Control Register (TBCON)	11-6
Timer B Pulse Width Calculations	11-7

Chapter 12 16-Bit Timer 1(0, 1)

Overview.....	12-1
Function Description	12-2
Timer 1(0,1) Control Register (T1CON0, T1CON1)	12-3
Block Diagram.....	12-6

Chapter 13 10-bit PWM (Pulse width Modulation)

Overview.....	13-1
Function Description.....	13-1
PWM	13-1
PWM Control Register (PWMCON).....	13-5

Chapter 14 Serial I/O Interface

Overview.....	14-1
Programming Procedure.....	14-1
Serial I/O Control Registers (SIOCON)	14-2
SIO Prescaler Register (SIOPS).....	14-3

Table of Contents (Continued)

Chapter 15 **UART**

Overview	15-1
Programming Procedure	15-1
UART Control Register (UARTCON)	15-2
UART Interrupt Pending Register (UARTPND)	15-4
UART Data Register (UDATA)	15-5
UART Baud Rate Data Register (BRDATAH, BRDATAL)	15-6
Baud Rate Calculations	15-6
Block Diagram	15-8
UART Mode 0 Function Description	15-9
UART Mode 1 Function Description	15-10
UART Mode 2 Function Description	15-11
Serial Communication for Multiprocessor Configurations	15-13

Chapter 16 **A/D Converter**

Overview	16-1
Function Description	16-1
A/D Converter Control Register (ADCON)	16-2
Internal Reference Voltage Levels	16-4
Conversion timing	16-4
Internal A/D Conversion Procedure	16-5

Chapter 17 **Watch Timer**

Overview	17-1
Watch Timer Control Register (WTCN: R/W)	17-2
Watch Timer Circuit Diagram	17-3

Chapter 18 **Low Voltage Reset**

Overview	18-1
----------------	------

Table of Contents (Continued)

Chapter 19 MTP

Overview.....	19-1
---------------	------

Chapter 20 Electrical Data

Overview.....	20-1
---------------	------

Chapter 21 Mechanical Data

Overview.....	21-1
---------------	------

Chapter 22 Development Tools

Overview.....	22-1
SHINE	22-1
SASM	22-1
SAMA Assembler.....	22-1
HEX2ROM	22-1
Target Boards	22-2
TB84H5 Target Board.....	22-3
IDLE LED	22-4
STOP LED	22-4

List of Figures

Figure Number	Title	Page Number
1-1	S3C84H5/F84H5 Block Diagram.....	1-3
1-2	S3C84H5/F84H5 Pin Assignment (32-pin SOP/SDIP)	1-4
1-3	S3C84H5/F84H5 Pin Assignment (30-pin SDIP)	1-5
1-4	S3C84H5/F84H5 Pin Assignment (28-pin SOP)	1-6
1-5	Pin Circuit Type B (nRESET)	1-11
1-6	Pin Circuit Type C	1-11
1-7	Pin Circuit Type D	1-12
1-8	Pin Circuit Type D-5 (P1.0~P1.3)	1-12
1-9	Pin Circuit Type E(P2.2~P2.3,P1.4~1.5).....	1-13
1-10	Pin Circuit Type G (P3.0-P3.4)	1-14
2-1	Program Memory Address Space	2-2
2-2	Smart Option.....	2-3
2-3	Internal Register File Organization	2-5
2-4	Register Page Pointer (PP)	2-6
2-5	Set 1, Set 2, Prime Area Register	2-9
2-6	8-Byte Working Register Areas (Slices)	2-10
2-7	Contiguous 16-Byte Working Register Block	2-11
2-8	Non-Contiguous 16-Byte Working Register Block	2-12
2-9	16-Bit Register Pair	2-13
2-10	Register File Addressing	2-14
2-11	Common Working Register Area.....	2-15
2-12	4-Bit Working Register Addressing	2-17
2-13	4-Bit Working Register Addressing Example	2-17
2-14	8-Bit Working Register Addressing	2-18
2-15	8-Bit Working Register Addressing Example	2-19
2-16	Stack Operations	2-20
3-1	Register Addressing	3-2
3-2	Working Register Addressing.....	3-2
3-3	Indirect Register Addressing to Register File.....	3-3
3-4	Indirect Register Addressing to Program Memory	3-4
3-5	Indirect Working Register Addressing to Register File	3-5
3-6	Indirect Working Register Addressing to Program or Data Memory	3-6
3-7	Indexed Addressing to Register File	3-7
3-8	Indexed Addressing to Program or Data Memory with Short Offset	3-8
3-9	Indexed Addressing to Program or Data Memory.....	3-9
3-10	Direct Addressing for Load Instructions	3-10
3-11	Direct Addressing for Call and Jump Instructions	3-11
3-12	Indirect Addressing.....	3-12
3-13	Relative Addressing.....	3-13
3-14	Immediate Addressing.....	3-14
4-1	Register Description Format.....	4-4

List of Figures (Continued)

Figure Number	Title	Page Number
5-1	S3C8-Series Interrupt Types	5-2
5-2	S3C84H5/F84H5 Interrupt Structure	5-4
5-3	ROM Vector Address Area	5-5
5-4	Interrupt Function Diagram	5-8
5-5	System Mode Register (SYM)	5-10
5-6	Interrupt Mask Register (IMR)	5-11
5-7	Interrupt Request Priority Groups	5-12
5-8	Interrupt Priority Register (IPR)	5-13
5-9	Interrupt Request Register (IRQ)	5-14
6-1	System Flags Register (FLAGS)	6-6
7-1	Main Oscillator Circuit (Crystal or Ceramic Oscillator)	7-1
7-2	Sub-System Oscillator Circuit (Crystal Oscillator)	7-1
7-3	System Clock Circuit Diagram	7-2
7-4	System Clock Control Register (CLKCON)	7-3
7-5	Oscillator Control Register (OSCCON)	7-4
7-6	STOP Control Register (STOPCON)	7-4
9-1	Port 0 Low Byte Control Register (P0CON)	9-3
9-2	Port 1 High-Byte Control Register (P1CONH)	9-5
9-3	Port 1 Low-Byte Control Register (P1CONL)	9-6
9-4	Port 1 Interrupt Pending Register (P1INTPND)	9-7
9-5	Port 1 Interrupt Enable Register (P1INT)	9-8
9-6	Port 2 High-Byte Control Register (P2CONH)	9-9
9-7	Port 2 Low-Byte Control Register (P2CONL)	9-10
9-8	Port 2 Pull-up Control Register (P2PUR)	9-11
9-9	Port 3 Low-Byte Control Register (P3CONL)	9-12
10-1	Basic Timer Control Register (BTCON)	10-2
10-2	Basic Timer Block Diagram	10-4
11-1	Timer A Control Register (TACON)	11-3
11-2	Timer A Functional Block Diagram	11-4
11-3	Timer B Functional Block Diagram	11-5
11-4	Timer B Control Register (TBCON)	11-6
11-5	Timer B Data Registers (TBDATAH, TBDATAL)	11-6
11-6	Timer B Output Flip Flop Waveforms in Repeat Mode	11-8

List of Figures (Concluded)

Figure Number	Title	Page Number
12-1	Timer 1(0,1) Control Register (T1CON0, T1CON1).....	12-4
12-2	Timer A, Timer 1(0,1) Pending Register (TINTPND)	12-5
12-3	Timer 1(0,1) Functional Block Diagram.....	12-6
13-1	10-Bit PWM Basic Waveform	13-3
13-2	10-Bit Extended PWM Waveform.....	13-4
13-3	PWM Control Register (PWMCON)	13-5
13-4	PWM Functional Block Diagram.....	13-6
14-1	Serial I/O Interface Control Register (SIOCON).....	14-2
14-2	SIO Pre-scaler Register (SIOPS)	14-3
14-3	SIO Functional Block Diagram	14-3
14-4	Serial I/O Timing in Transmit-Receive Mode (Tx at falling, SIOCON.4 = 0)	14-4
14-5	Serial I/O Timing in Transmit-Receive Mode (Tx at rising, SIOCON.4 = 1).....	14-4
14-6	Serial I/O Timing in Receive-Only Mode	14-5
15-1	UART Control Register (UARTCON)	15-3
15-2	UART Interrupt Pending Register (UARTPND).....	15-4
15-3	UART Data Register (UDATA)	15-5
15-4	UART Baud Rate Data Register (BRDATAH, BRDATAL)	15-6
15-5	UART Functional Block Diagram.....	15-8
15-6	Timing Diagram for UART Mode 0 Operation	15-9
15-7	Timing Diagram for UART Mode 1 Operation	15-10
15-8	Timing Diagram for UART Mode 2 Operation	15-12
15-9	Connection Example for Multiprocessor Serial Data Communications	15-14
16-1	A/D Converter Control Register (ADCON)	16-2
16-2	A/D Converter Data Register (ADDATAH, ADDATAL)	16-3
16-3	A/D Converter Circuit Diagram	16-3
16-4	A/D Converter Timing Diagram	16-4
16-5	Recommended A/D Converter Circuit for Highest Absolute Accuracy	16-5
17-1	Watch Timer Circuit Diagram	17-3
18-1	Low Voltage Reset Circuit	18-2

List of Figures (Concluded)

Figure Number	Title	Page Number
19-1	Pin Assignment (32-pin SOP/SDIP)	19-1
19-2	Pin Assignment (30-pin SDIP)	19-2
19-3	Pin Assignment (28-pin SOP)	19-3
20-1	Input Timing for External Interrupts (Ports 2)	20-5
20-2	Input Timing for RESET	20-5
20-3	Clock Timing Measurement at X_{IN}	20-7
20-4	Stop Mode Release Timing initiated by RESET	20-8
20-5	Stop Mode (Main) Release Timing Initiated by Interrupts	20-9
20-6	Stop Mode (Sub) Release Timing Initiated by Interrupts	20-9
20-7	Waveform for UART Timing Characteristics	20-10
20-8	Operating Voltage Range	20-12
20-9	The Circuit Diagram to Improve EFT Characteristics	20-13
21-1	32-SOP-450A Package Dimensions	21-1
21-2	32-SDIP-400 Package Dimensions	21-2
21-3	30-Pin SDIP Package Dimensions	21-3
21-4	28-SOP-375 Package Dimensions	21-4
22-1	SMDS+ or SK-1000 Product Configuration	22-2
22-2	S3F84I9/ S3F84I8/S3F84H5 Target Board Configuration	22-3
22-3	44-Pin Connector pin assignment for TB84H5	22-5
22-4	42-Pin Connector Pin Assignment for TB84H5	22-6
22-5	TB84H5 Adapter Cable for 44pin Connector Package	22-6

List of Tables

Table Number	Title	Page Number
1-1	S3C84H5/F84H5 Pin Descriptions (32SOP/32SDIP/28SOP).....	1-7
1-2	S3C84H5/F84H5 Pin Descriptions (30 SDIP).....	1-9
2-1	S3C84H5/F84H5 Register Type Summary.....	2-4
4-1	Set 1 Registers.....	4-1
4-2	Set 1, Bank 0 Registers.....	4-2
4-3	Set 1, Bank 1 Registers.....	4-3
5-1	Interrupt Vectors.....	5-6
5-2	Interrupt Control Register Overview.....	5-7
5-3	Interrupt Source Control and Data Registers.....	5-9
6-1	Instruction Group Summary.....	6-2
6-2	Flag Notation Conventions.....	6-8
6-3	Instruction Set Symbols.....	6-8
6-4	Instruction Notation Conventions.....	6-9
6-5	Opcode Quick Reference.....	6-10
6-6	Condition Codes.....	6-12
8-1	S3C84H5/F84H5 Set 1 Register values after RESET.....	8-2
8-2	S3C84H5/F84H5 Set 1, Bank 0 Register values after RESET.....	8-3
8-3	S3C84H5/F84H5 Set 1, Bank 1 Register values after RESET.....	8-4
9-1	S3C84H5/F84H5 Port Configuration Overview.....	9-1
9-2	Port Data Register Summary.....	9-2
13-1	PWM Control and Data Registers.....	13-2
13-2	PWM output "stretch" Values for Extension Data Register (PWMDATAL .1-.0).....	13-3
15-1	Commonly Used Baud Rates Generated by 16bit BRDATA.....	15-7
17-1	Watch Timer Control Register (WTCON): Set 1, Bank 1, F8H, R/W.....	17-2
19-1	Descriptions of Pins Used to Read/Write the Flash ROM.....	19-4
19-2	Comparison of S3F84H5 and S3C84H5 Features.....	19-4

List of Tables

Table Number	Title	Page Number
20-1	Absolute Maximum Ratings	20-2
20-2	Input/Output Capacitance	20-2
20-3	D.C. Electrical Characteristics	20-3
20-4	A.C. Electrical Characteristics	20-5
20-5	Main Oscillator Frequency (f_{OSC1}).....	20-6
20-6	Main Oscillator Clock Stabilization Time (t_{ST1}).....	20-6
20-7	Sub Oscillator Frequency (f_{OSC2})	20-7
20-8	Subsystem Oscillator (crystal) Stabilization Time (t_{ST2}).....	20-7
20-9	Data Retention Supply Voltage in Stop Mode	20-8
20-10	UART Timing Characteristics in Mode 0 (10 MHz).....	20-10
20-11	A/D Converter Electrical Characteristics	20-11
20-12	LVR(Low Voltage Reset) Circuit Characteristics	20-12
22-1	Power Selection Settings for TB84H5	22-4
22-2	Using Single Header Pins as the Input Path for External Trigger Sources	22-4

List of Programming Tips

Description	Page Number
Chapter 2: Address Spaces	
Using the Page Pointer for RAM clear	2-7
Setting the Register Pointers	2-11
Using the RPs to Calculate the Sum of a Series of Registers	2-12
Addressing the Common Working Register Area	2-16
Standard Stack Operations Using PUSH and POP	2-21
 Chapter 9: I/O Ports	
Using the Timer A	9-13
Using Ports	9-14
 Chapter 11: 8-bit Timer A/B	
To generate 38 kHz, 1/3duty signal through P2.0	11-9
To generate a one pulse signal through P2.0	11-10
Using the Timer A	11-11
Using the Timer B	11-12
 Chapter 12: 16-bit Timer 1(0,1)	
Using the Timer 1(0)	12-7
 Chapter 13: 10-Bit PWM (Pulse Width Modulation)	
Programming the PWM Module to Sample Specifications	13-7
 Chapter 14: Serial I/O Interface	
SIO	14-5
 Chapter 16: A/D Converter	
Configuring A/D Converter	16-6
 Chapter 17: Watch Timer	
Using the Watch Timer	17-4

List of Register Descriptions

Register Identifier	Full Register Name	Page Number
ADCON	A/D Converter Control Register	4-5
BTCON	Basic Timer Control Register	4-6
CLKCON	System Clock Control Register.....	4-7
FLAGS	System Flags Register	4-8
IMR	Interrupt Mask Register.....	4-9
IPH	Instruction Pointer (High Byte).....	4-10
IPL	Instruction Pointer (Low Byte).....	4-10
IPR	Interrupt Priority Register	4-11
IRQ	Interrupt Request Register	4-12
OSCCON	Oscillator Control Register	4-13
P0CON	Port 0 Control Register (High Byte).....	4-14
P1CONH	Port 1 Control Register (High Byte).....	4-15
P1CONL	Port 1 Control Register (Low Byte).....	4-16
P1INTPND	Port 1 Interrupt Pending Register	4-17
P1INT	Port 1 Interrupt Enable	4-18
P2CONH	Port 2 Control Register (High Byte).....	4-19
P2CONL	Port 2 Control Register (Low Byte).....	4-20
P2PUR	Port 2 Pull-up Resistor Control Register	4-21
P3CONL	Port 3 Control Register (Low Byte).....	4-22
PP	Register Page Pointer	4-23
PWMCON	PWM Control Register	4-24
RP0	Register Pointer 0	4-25
RP1	Register Pointer 1	4-25
SIOCON	Serial I/O Module Control Registers	4-26
SIOPS	SIO Prescaler Register.....	4-27
SPH	Stack Pointer (High Byte).....	4-27
SPL	Stack Pointer (Low Byte).....	4-27
STOPCON	Stop Control Register	4-28
SYM	System Mode Register	4-29
T1CON0	Timer 1(0) Control Register.....	4-30
T1CON1	Timer 1(1) Control Register.....	4-31
TACON	Timer A Control Register.....	4-32
TBCON	Timer B Control Register.....	4-33
TINTPND	Timer A, Timer 1 Interrupt Pending Register	4-34
UARTCON	UART Control Register	4-35
UARTPND	UART Pending and parity control.....	4-37
WTCON	Watch Timer Control Register	4-38

List of Instruction Descriptions

Instruction Mnemonic	Full Register Name	Page Number
ADC	Add with Carry.....	6-14
ADD	Add.....	6-15
AND	Logical AND.....	6-16
BAND	Bit AND.....	6-17
BCP	Bit Compare.....	6-18
BITC	Bit Complement.....	6-19
BITR	Bit Reset.....	6-20
BITR	Bit Reset.....	6-20
BITS	Bit Set.....	6-21
BOR	Bit OR.....	6-22
BTJRF	Bit Test, Jump Relative on False.....	6-23
BTJRT	Bit Test, Jump Relative on True.....	6-24
BXOR	Bit XOR.....	6-25
CALL	Call Procedure.....	6-26
CCF	Complement Carry Flag.....	6-27
CLR	Clear.....	6-28
COM	Complement.....	6-29
CP	Compare.....	6-30
CPIJE	Compare, Increment, and Jump on Equal.....	6-31
CPIJNE	Compare, Increment, and Jump on Non-Equal.....	6-32
DA	Decimal Adjust.....	6-33
DA	Decimal Adjust.....	6-34
DEC	Decrement.....	6-35
DECW	Decrement Word.....	6-36
DI	Disable Interrupts.....	6-37
DIV	Divide (Unsigned).....	6-38
DJNZ	Decrement and Jump if Non-Zero.....	6-39
EI	Enable Interrupts.....	6-40
ENTER	Enter.....	6-41
EXIT	Exit.....	6-42
IDLE	Idle Operation.....	6-43
INC	Increment.....	6-44
INCW	Increment Word.....	6-45
IRET	Interrupt Return.....	6-46
JP	Jump.....	6-47
JR	Jump Relative.....	6-48
LD	Load.....	6-49
LD	Load.....	6-50
LDB	Load Bit.....	6-51

List of Instruction Descriptions (Continued)

Instruction Mnemonic	Full Register Name	Page Number
LDC/LDE	Load Memory.....	6-52
LDC/LDE	Load Memory.....	6-53
LDCD/LDED	Load Memory and Decrement.....	6-54
LDCI/LDEI	Load Memory and Increment.....	6-55
`LDCPD/LDEPD	Load Memory with Pre-Decrement.....	6-55
LDCPD/LDEPD	Load Memory with Pre-Decrement.....	6-56
LDCPI/LDEPI	Load Memory with Pre-Increment.....	6-57
LDW	Load Word.....	6-58
MULT	Multiply (Unsigned).....	6-59
NEXT	Next.....	6-60
NOP	No Operation.....	6-61
OR	Logical OR.....	6-62
POP	Pop from Stack.....	6-63
POPUD	Pop User Stack (Decrementing).....	6-64
POPUI	Pop User Stack (Incrementing).....	6-65
PUSH	Push to Stack.....	6-66
PUSHUD	Push User Stack (Decrementing).....	6-67
PUSHUI	Push User Stack (Incrementing).....	6-68
RCF	Reset Carry Flag.....	6-69
RET	Return.....	6-70
RL	Rotate Left.....	6-71
RLC	Rotate Left through Carry.....	6-72
RR	Rotate Right.....	6-73
RRC	Rotate Right through Carry.....	6-74
SB0	Select Bank 0.....	6-75
SB1	Select Bank 1.....	6-76
SBC	Subtract with Carry.....	6-77
SCF	Set Carry Flag.....	6-78
SRA	Shift Right Arithmetic.....	6-79
SRP/SRP0/SRP1	Set Register Pointer.....	6-80
STOP	Stop Operation.....	6-81
SUB	Subtract.....	6-82
SWAP	Swap Nibbles.....	6-83
TCM	Test Complement under Mask.....	6-84
TM	Test under Mask.....	6-85
WFI	Wate for Interrupt.....	6-86
XOR	Logical Exclusive OR.....	6-87

1

PRODUCT OVERVIEW

S3C8-SERIES MICROCONTROLLERS

Samsung's S3C8-series of 8-bit single-chip CMOS microcontrollers offers a fast and efficient CPU, a wide range of integrated peripherals, and various mask-programmable ROM sizes. The major CPU features are:

- Efficient register-oriented architecture
- Selectable CPU clock sources
- Idle and Stop power-down mode released by interrupt or reset
- Built-in basic timer with watchdog function

A sophisticated interrupt structure recognizes up to eight-interrupt levels. Each level can have one or more interrupt sources and vectors. Fast interrupt processing (within a minimum of four CPU clocks) can be assigned to specific interrupt levels.

S3C84H5/F84H5 MICROCONTROLLER

The S3C84H5/F84H5 single-chip CMOS microcontrollers are fabricated using the highly advanced CMOS process technology based on Samsung's latest CPU architecture.

The S3C84H5 is a microcontroller with a 16K-byte mask-programmable ROM embedded.

The S3F84H5 is a microcontroller with a 16K-byte Flash ROM embedded.

Using a proven modular design approach, Samsung engineers have successfully developed the S3C84H5/F84H5 by integrating the following peripheral modules with the powerful SAM8 core:

- Five programmable I/O ports (32 SOP/SDIP: 22pins, 30 SDIP: 20pins, 28 SOP: 18pins) including ports shared with segment/common drive outputs.
- Four bit-programmable pins for external interrupts.
- One 8-bit basic timer for oscillation stabilization and watchdog function (system reset).
- Two 8-bit timer/counter and Two 16-bit timer/counter with selectable operating modes.
- One asynchronous UART and One synchronous SIO
- One 10-bit PWM output
- 10-bit 8-channel A/D converter
- Watch timer for real time

The S3C84H5/F84H5 is versatile microcontroller for home appliances and ADC applications, etc. They are currently available in 32 SOP/SDIP, 30 SDIP, 28 SOP package.

FEATURES

CPU

- SAM8RC CPU core

Memory

- 272-bytes internal register file
- 16Kbytes internal multi time program memory

Oscillation Sources

- Main clock oscillator (Crystal, Ceramic)
- CPU clock divider (1/1, 1/2, 1/8, 1/16)

Instruction Set

- 78 instructions
- IDLE and STOP instructions added for power-down modes

Instruction Execution Time

- 400 ns at 10-MHz f_{osc} (minimum)

Interrupts

- 16 interrupt sources with 16 vectors.
- 8 level, 16 vector interrupt structure

I/O Ports

- Total 22 bit-programmable pins (32 SOP/SDIP)
Total 20 bit-programmable pins (30 SDIP)
Total 18 bit-programmable pins (28SOP)

Timers and Timer/Counters

- One programmable 8-bit basic timer (**BT**) for oscillation stabilization control or watchdog timer function.
- One 8-bit timer/counter (**Timer A**) with three operating modes; Interval mode, capture mode and PWM mode.
- One 8-bit timer (**Timer B**) with carrier frequency (or PWM) generator.
- Two 16-bit timer/counter (**Timer 10,11**) with three operating modes; Interval mode, Capture mode, and PWM mode.

Watch Timer

- Real-time and interval time measurement.
- Four frequency output to BUZ pin.

A/D Converter

- 10-bit resolution
- Eight-analog input channels
- 20us conversion speed at 10MHz f_{ADC} clock.

Asynchronous UART

- One Asynchronous UART
- Programmable baud rate generator
- Supports serial data transmit/receive operations with 8-bit, 9-bit in UART

PWM Module

- One 10-bit programmable PWM output

Serial I/O

- One synchronous serial I/O module
- Selectable transmit and receive rates

Built-in RESET Circuit (LVR)

- Low-Voltage check to make system reset
- $V_{LVR} = 2.8V$ (by smart option)

Oscillation Frequency

- 1MHz to 10MHz external crystal oscillator

Operating Temperature Range

- $-25^{\circ}C$ to $+85^{\circ}C$

Operating Voltage Range

- LVR on : LVR to 5.5 V (8MHz)
- LVR off : 2.5 V to 5.5 V(8MHz)
- LVR off/on : 4.5 V to 5.5 V(10MHz)

Package Type

- 32 pin SOP/SDIP, 30 pin SDIP
- 28SOP

BLOCK DIAGRAM

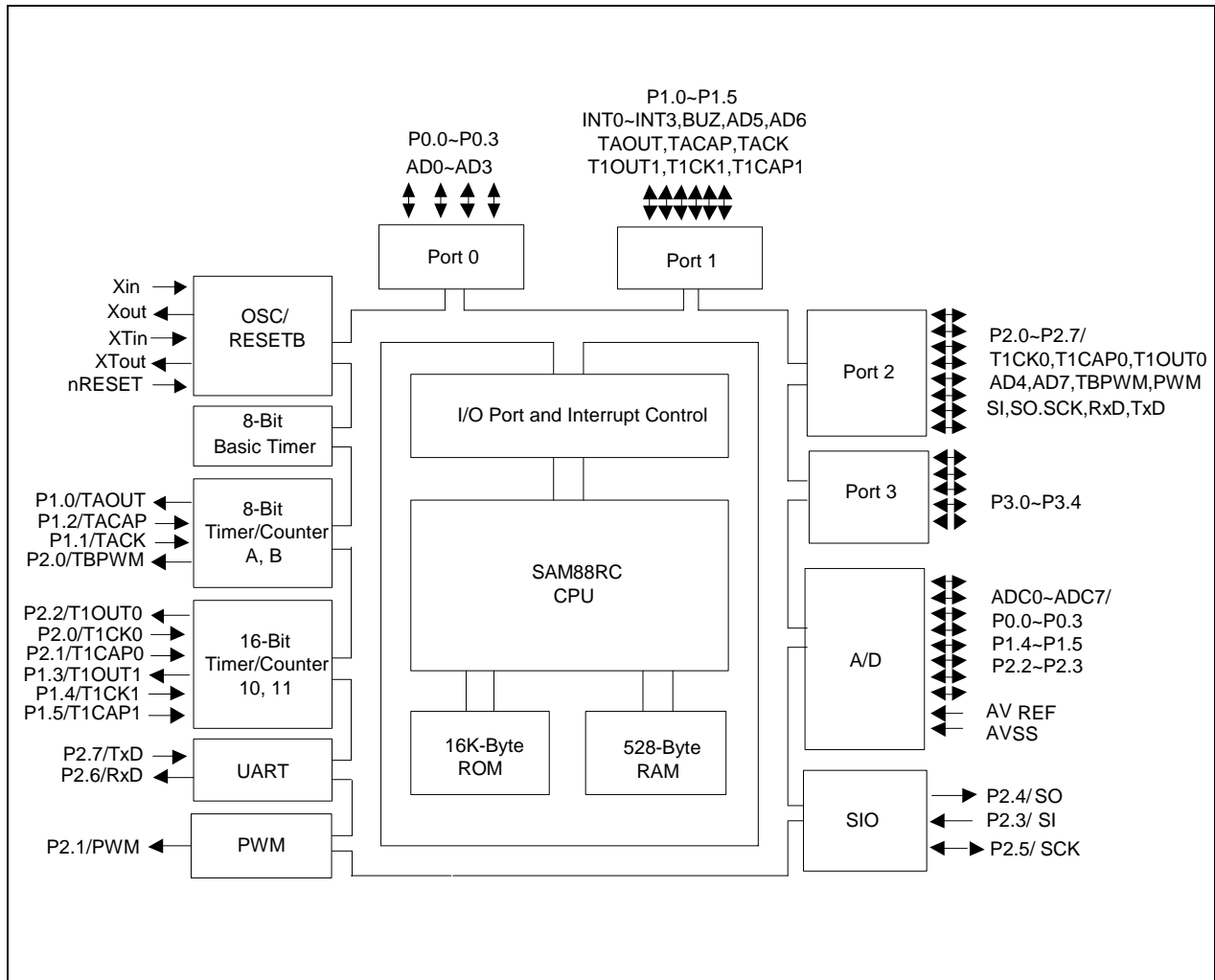


Figure 1-1. S3C84H5/F84H5 Block Diagram

PIN ASSIGNMENT

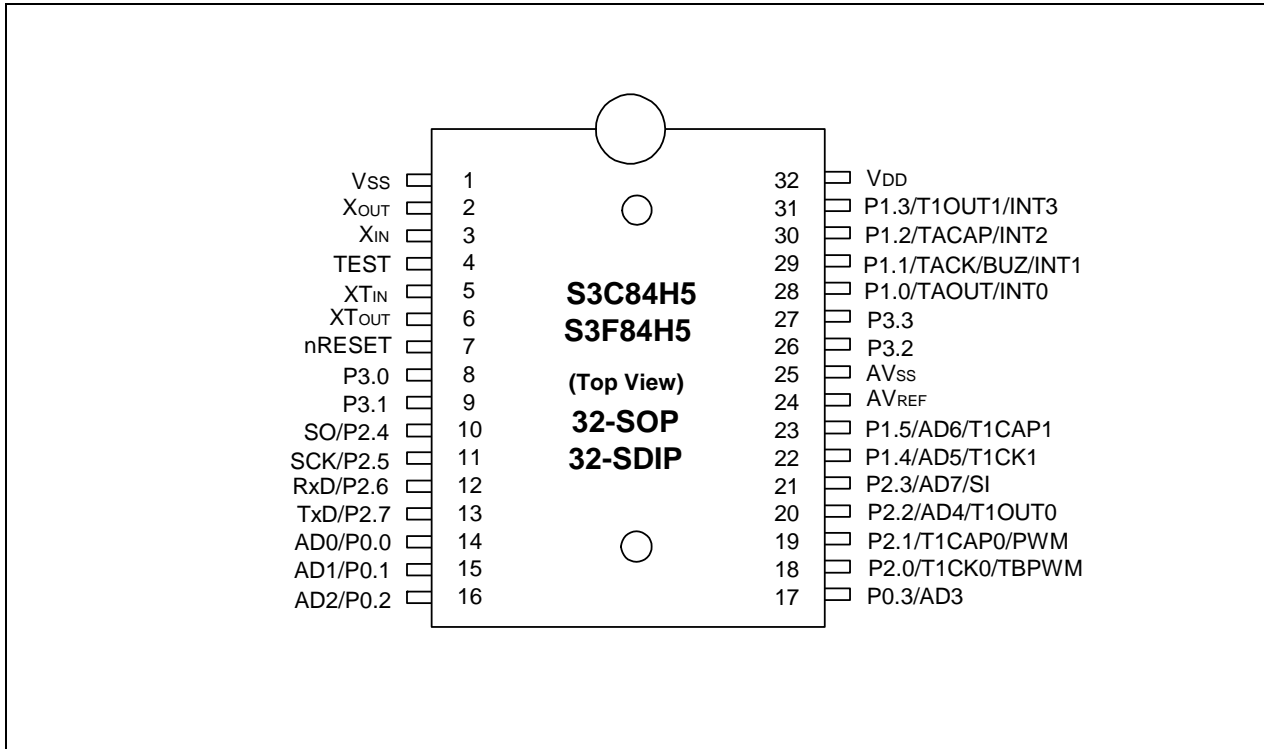


Figure 1-2. S3C84H5/F84H5 Pin Assignment (32-pin SOP/SDIP)

PIN ASSIGNMENT

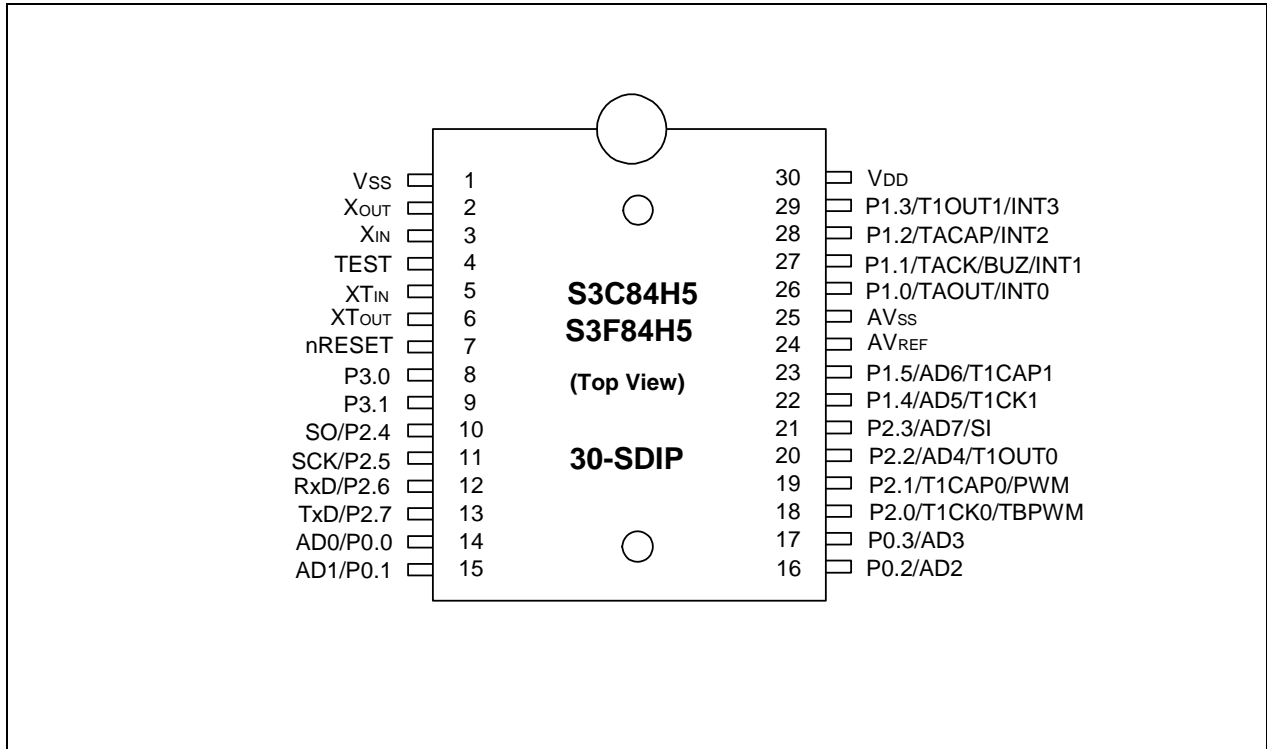


Figure 1-3. S3C84H5/F84H5 Pin Assignment (30-pin SDIP)

PIN ASSIGNMENT

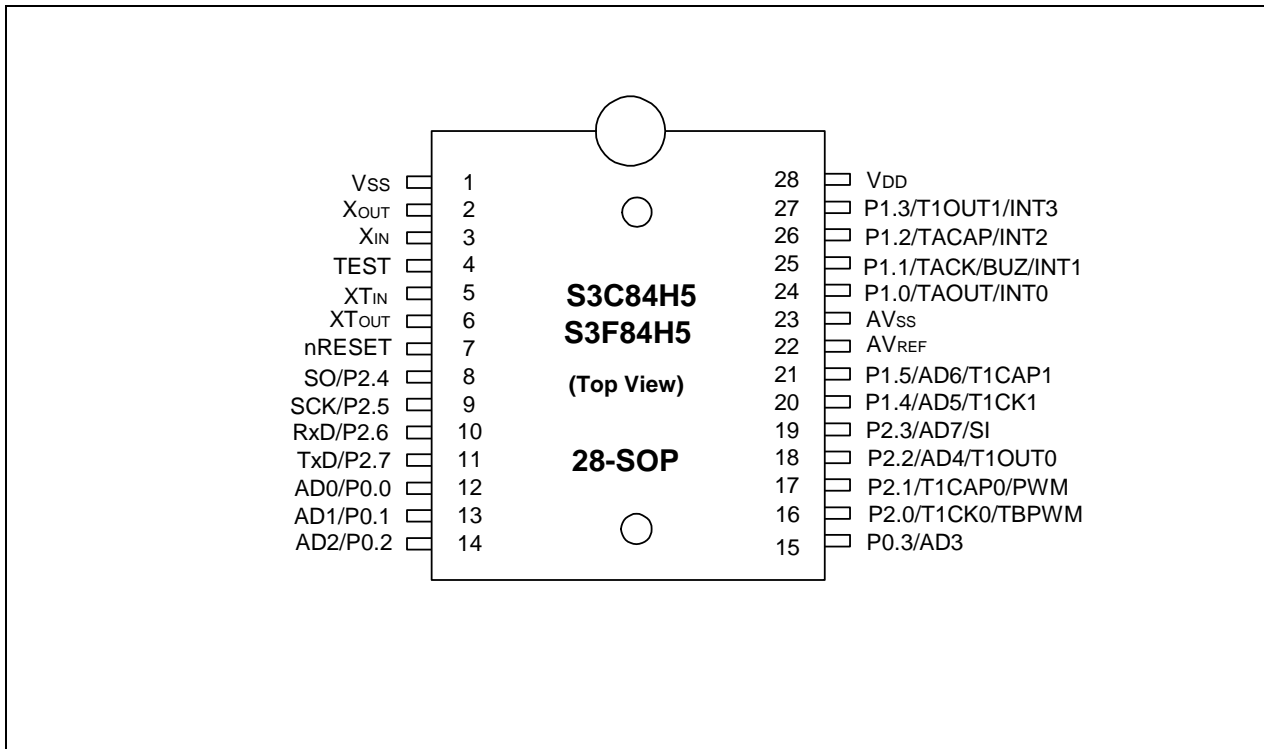


Figure 1-4. S3C84H5/F84H5 Pin Assignment (28-pin SOP)

PIN DESCRIPTIONS

Table 1-1. S3C84H5/F84H5 Pin Descriptions (32SOP/32SDIP/28SOP)

Pin Name	Pin Type	Pin Description	Circuit Type	Pin Number	Share Pins
P0.0–P0.3	I/O	Bit programmable port; input or output mode selected by software; input or push-pull output. Software assignable pull-up resistor. Alternately, can be used as AD0–AD3	E	14-17 (12-15)	ADC0, ADC1, ADC2, ADC3
P1.0–P1.5	I/O	Bit programmable port; input or output mode selected by software; input or push-pull output. Software assignable pull-up resistor. Alternatively can be used as INT0–INT3, TAOUT, TACK, TACAP, T1CAP1, T1CK1, T1OUT1, AD5, AD6	D-5 E	22-23 28-31 (20-21 24-27)	INT0~INT3 TAOUT, TACK TACAP, T1CK1 T1CAP1, AD5 T1OUT1, AD6, BUZ
P2.0–P2.7	I/O	Bit programmable port; input or output mode selected by software; input or push-pull output. Software assignable pull-up. Alternately, can be used as ADC4,ADC7,SI T1CAP0, T1OUT0, T1CK0, SO, SCK, RxD, TxD TBPWM, PWM	E D-5	10-13,18-21 (16-19 8-11)	AD7 SO, SCK RxD, TxD, T1CAP0, T1CAP1, T1CK0, PWM, TBPWM
P3.0–P3.3	I/O	Bit programmable port; input or output mode selected by software; input or push-pull,N-channel open-drain output. Software assignable pull-up.	G	8-9, 26-27	

NOTE: Pin numbers shown in parentheses "()" are for the 28-pin SOP package.

Table 1-1. S3C84H5/F84H5 Pin Descriptions (Continued)

Pin Name	Pin Type	Pin Description	Circuit Type	Pin Number	Share Pins
INT0–INT3	I	Input pins for external interrupt. Alternatively used as general-purpose digital input/output port 1	D-5	28-31 (24-27)	P1.0–P1.3
ADC0–ADC7	I	Analog input pins for A/D converter module. Alternatively used as general-purpose digital input/output port 0, port1 and port 2.	E	14-17, 20-23, (12-5, 18-21)	P0.0–P0.3 P2.2–P2.3 P1.4-P1.5
AVREF, AVSS	–	A/D converter reference voltage and ground	–	24,25 (22,23)	–
RxD	I	Serial data RxD pin for receive input and transmit output (mode 0)	E	12 (10)	P2.6
TxD	O	Serial data TxD pin for transmit output and shift clock output (mode 0)	E	13 (11)	P2.7
TACK	I	External clock input pins for timer A	D-5	29(25)	P1.1
TACAP	I	Capture input pins for timer A	D-5	30(26)	P1.2
TAOUT	O	Pulse width modulation output pins for timer A	D-5	28(24)	P1.0
TBOUT	O	Carrier frequency output pins for timer B	D-5	18(16)	P2.0
T1CK0	I	External clock input pins for timer 1(0)	D-5	18(16)	P2.0
T1CAP0	I	Capture input pins for timer 1(0)	D-5	19(17)	P2.1
T1OUT0	O	Timer 1(0) 16-bit PWM mode output or counter match toggle output pins	D-5	20(18)	P2.2
T1CK1	I	External clock input pins for timer 1(1)	E	22(20)	P1.4
T1CAP1	I	Capture input pins for timer 1(1)	E	23(21)	P1.5
T1OUT1	O	Timer 1(1) 16-bit PWM mode output or counter match toggle output pins	E	31(27)	P1.3
nRESET	I	System reset pin	B	7	–
TEST	I	Pull-down resistor connected internally	–	4	–
V _{DD} , V _{SS}	–	Power input pins	–	1,32	–
Xin, Xout	I,O	Main oscillator pins	–	2,3	–

NOTE: Pin numbers shown in parentheses "()" are for the 28-pin SOP package.

Table 1-2. S3C84H5/F84H5 Pin Descriptions (30 SDIP)

Pin Name	Pin Type	Pin Description	Circuit Type	Pin Number	Share Pins
P0.0–P0.3	I/O	Bit programmable port; input or output mode selected by software; input or push-pull output. Software assignable pull-up resistor. Alternately, can be used as AD0~AD3	E	14-17	ADC0, ADC1, ADC2, ADC3
P1.0–P1.5	I/O	Bit programmable port; input or output mode selected by software; input or push-pull output. Software assignable pull-up resistor. Alternatively can be used as INT0~INT3, TAOUT, TACK, TACAP, T1CAP1, T1CK1, T1OUT1, AD5,AD6	D-5 E	22-23 26-29	INT0~INT3 TAOUT, TACK TACAP, T1CK1 , T1CAP1, AD5 T1OUT1, AD6, BUZ
P2.0–P2.7	I/O	Bit programmable port; input or output mode selected by software; input or push-pull output. Software assignable pull-up. Alternately, can be used as ADC4, ADC7, SI, T1CAP0, T1OUT0, T1CK0, SO, SCK, RxD, TxD TBPWM, PWM	E D-5	10-13, 18-21	ADC6~ADC7 SO, SCK RxD, TxD, T1CAP0, T1CAP1, T1CK0, PWM, TBPWM
P3.0–P3.3	I/O	Bit programmable port; input or output mode selected by software; input or push-pull, N-channel open-drain output. Software assignable pull-up.	G	8-9	

Table 1-2. S3C84H5/F84H5 Pin Descriptions (Continued)

Pin Name	Pin Type	Pin Description	Circuit Type	Pin Number	Share Pins
INT0–INT3	I	Input pins for external interrupt. Alternatively used as general-purpose digital input/output port 1	D-5	26-29	P1.0–P1.3
ADC0–ADC7	I	Analog input pins for A/D converter module. Alternatively used as general-purpose digital input/output port 0, port1 and port 2.	E	14-17, 20-23	P0.0–P0.3 P2.2–P2.3 P1.4–P1.5
AV _{REF} , AV _{SS}	–	A/D converter reference voltage and ground	–	24, 25	–
RxD	I	Serial data RxD pin for receive input and transmit output (mode 0)	E	12	P2.6
TxD	O	Serial data TxD pin for transmit output and shift clock output (mode 0)	E	13	P2.7
TACK	I	External clock input pins for timer A	D-5	27	P1.1
TACAP	I	Capture input pins for timer A	D-5	28	P1.2
TAOUT	O	Pulse width modulation output pins for timer A	D-5	26	P1.0
TBOUT	O	Carrier frequency output pins for timer B	D-5	18	P2.0
T1CK0	I	External clock input pins for timer 1(0)	D-5	18	P2.0
T1CAP0	I	Capture input pins for timer 1(0)	D-5	19	P2.1
T1OUT0	O	Timer 1(0) 16-bit PWM mode output or counter match toggle output pins	D-5	20	P2.2
T1CK1	I	External clock input pins for timer 1(1)	E	22	P1.4
T1CAP1	I	Capture input pins for timer 1(1)	E	23	P1.5
T1OUT1	O	Timer 1(1) 16-bit PWM mode output or counter match toggle output pins	E	29	P1.3
nRESET	I	System reset pin	B	7	–
TEST	I	Pull-down resistor connected internally	–	4	–
V _{DD} , V _{SS}	–	Power input pins	–	1, 32	–
Xin, Xout	I,O	Main oscillator pins	–	2, 3	–

PIN CIRCUITS

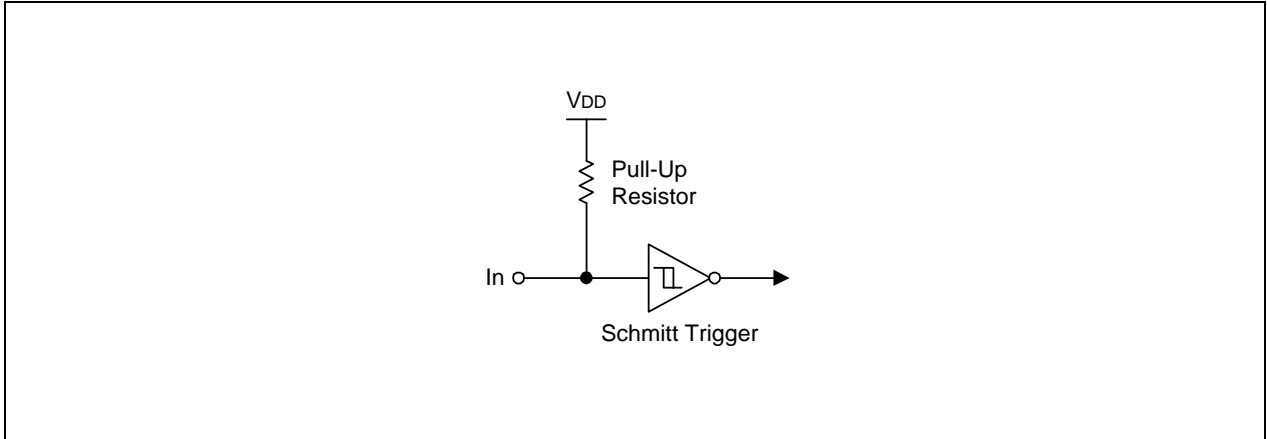


Figure 1-5. Pin Circuit Type B (nRESET)

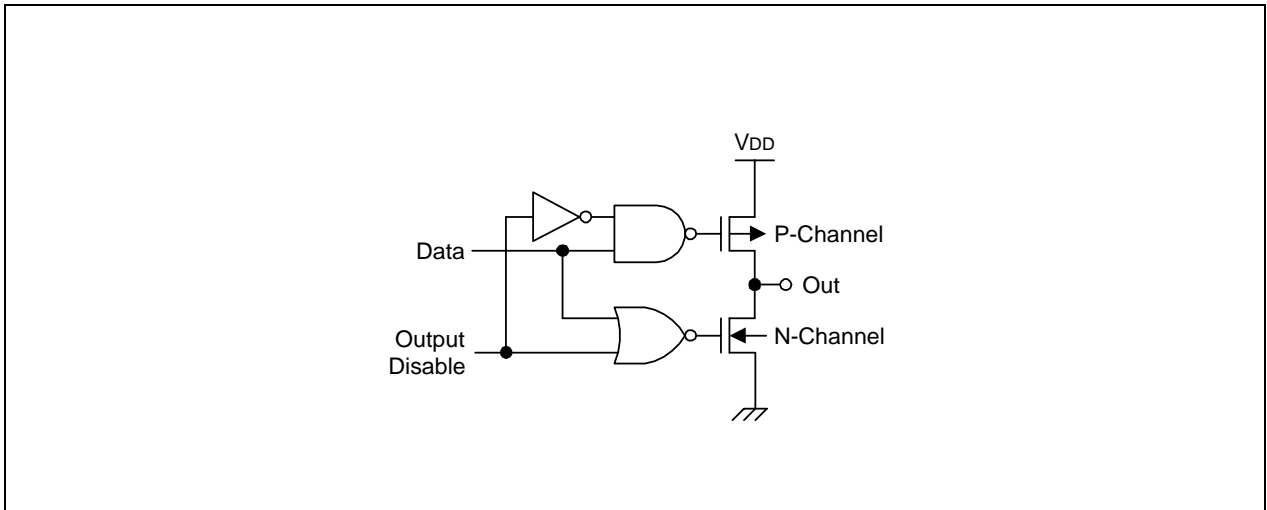


Figure 1-6. Pin Circuit Type C

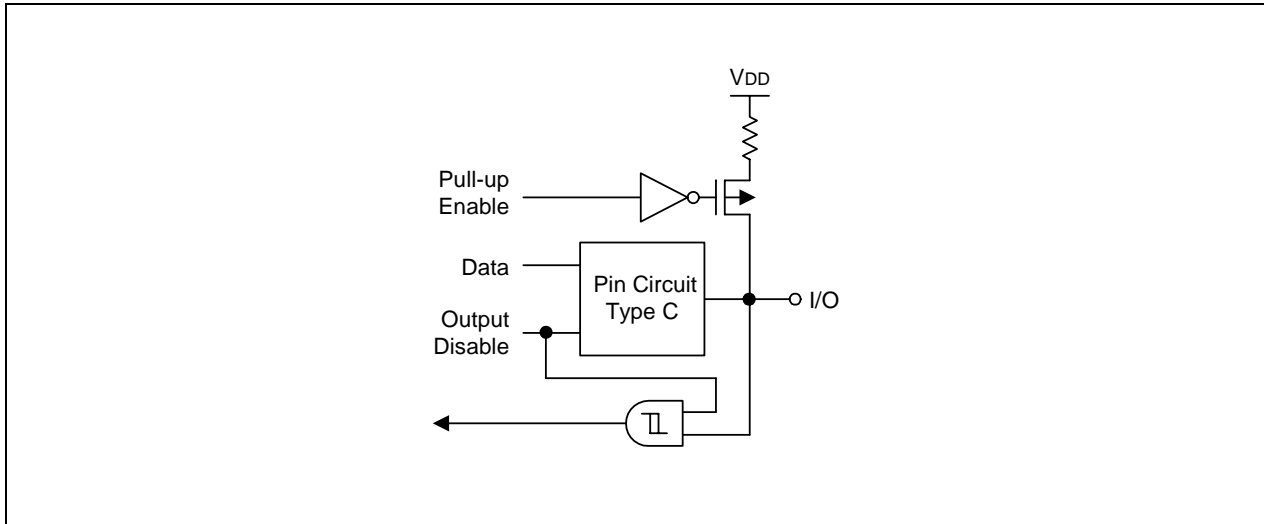


Figure 1-7. Pin Circuit Type D

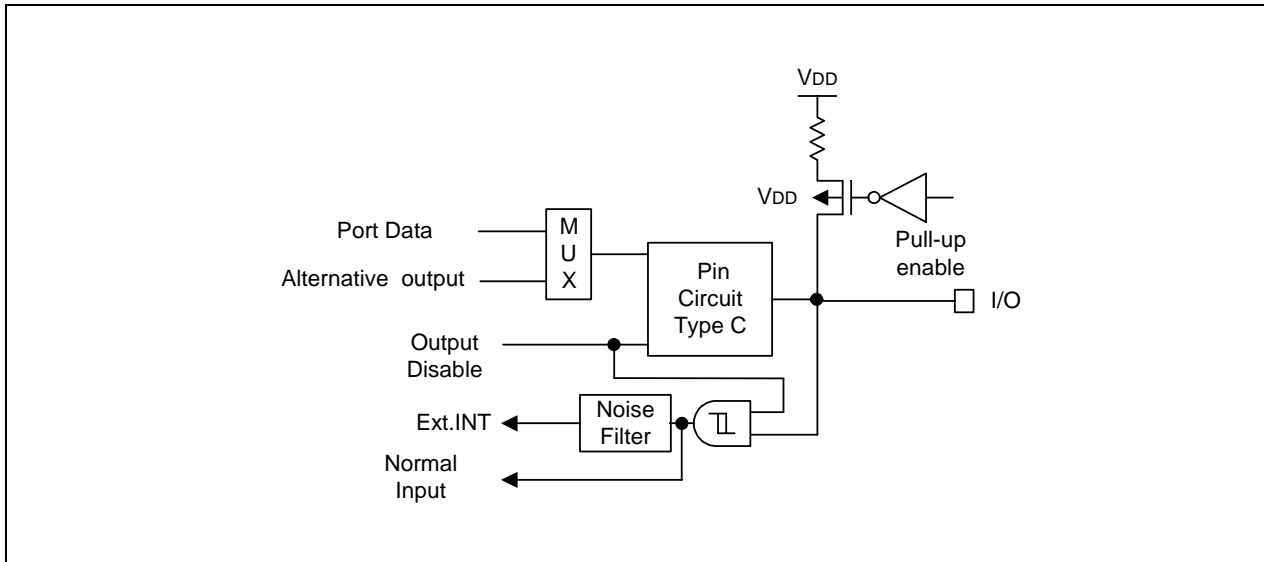


Figure 1-8. Pin Circuit Type D-5 (P1.0~P1.3)

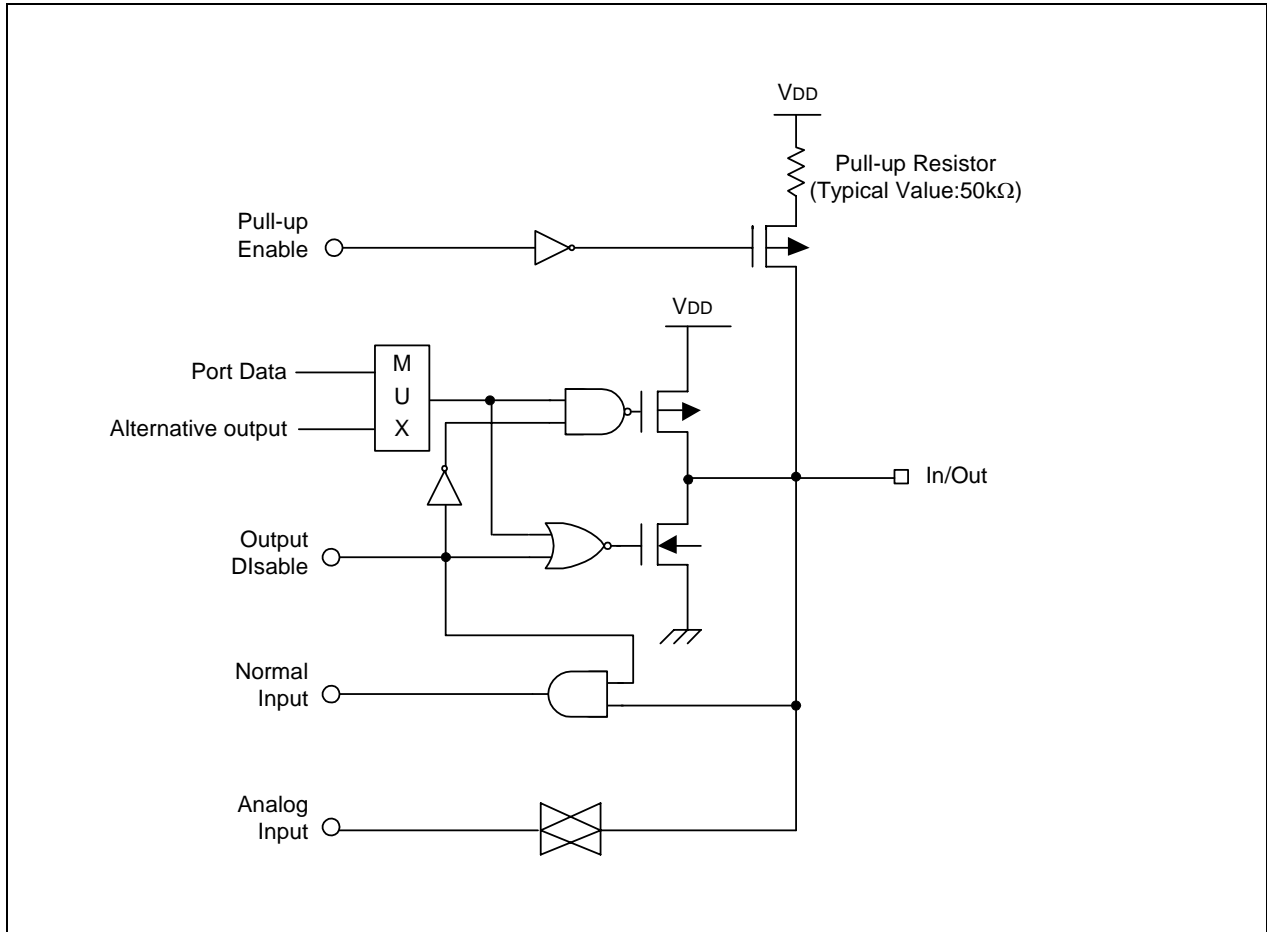


Figure 1-9. Pin Circuit Type E(P2.2~P2.3,P1.4~1.5)

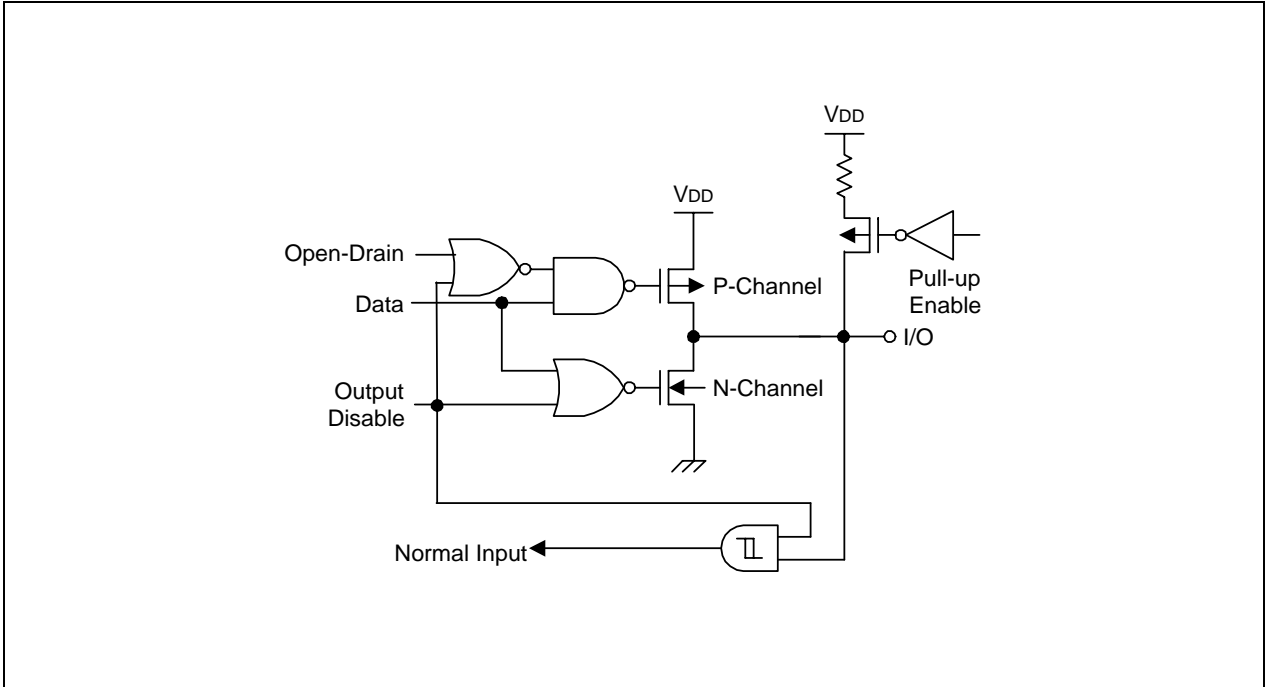


Figure 1-10. Pin Circuit Type G (P3.0-P3.4)

2 ADDRESS SPACES

OVERVIEW

The S3C84H5/F84H5 microcontroller has two types of address space:

- Internal program memory (ROM)
- Internal register file (RAM)

A 16-bit address bus supports program memory operations. A separate 8-bit register bus carries addresses and data between the CPU and the register file.

The S3C84H5/F84H5 has an internal 16-Kbyte mask-programmable ROM / 16-Kbyte Flash ROM and 272-byte RAM.

PROGRAM MEMORY (ROM)

Program memory (ROM) stores program codes or table data. The S3C84H5/F84H5 has 16 Kbytes of internal mask programmable program memory. The program memory address range is therefore 0H-3FFFH (see Figure 2-1).

The first 256 bytes of the ROM (0H-0FFH) are reserved for interrupt vector addresses. Unused locations in this address range can be used as normal program memory. If you use the vector address area to store a program code, be careful not to overwrite the vector addresses stored in these locations.

The ROM address at which a program execution starts after a reset is 0100H.

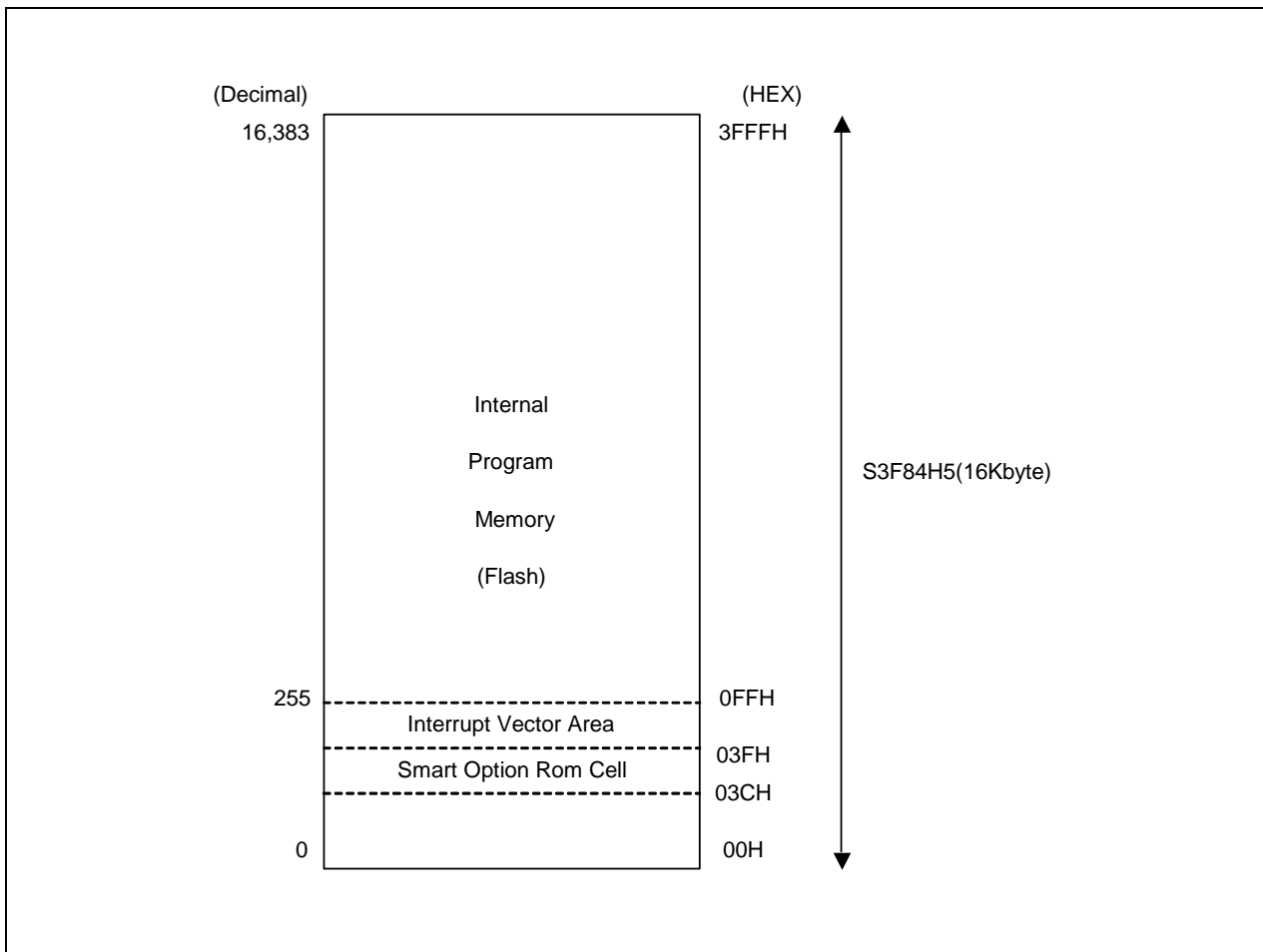


Figure 2-1. Program Memory Address Space

Smart Option

Smart option is the ROM option for starting condition of the chip. The ROM addresses used by smart option are from 003CH to 003FH. The default value of ROM is FFH.

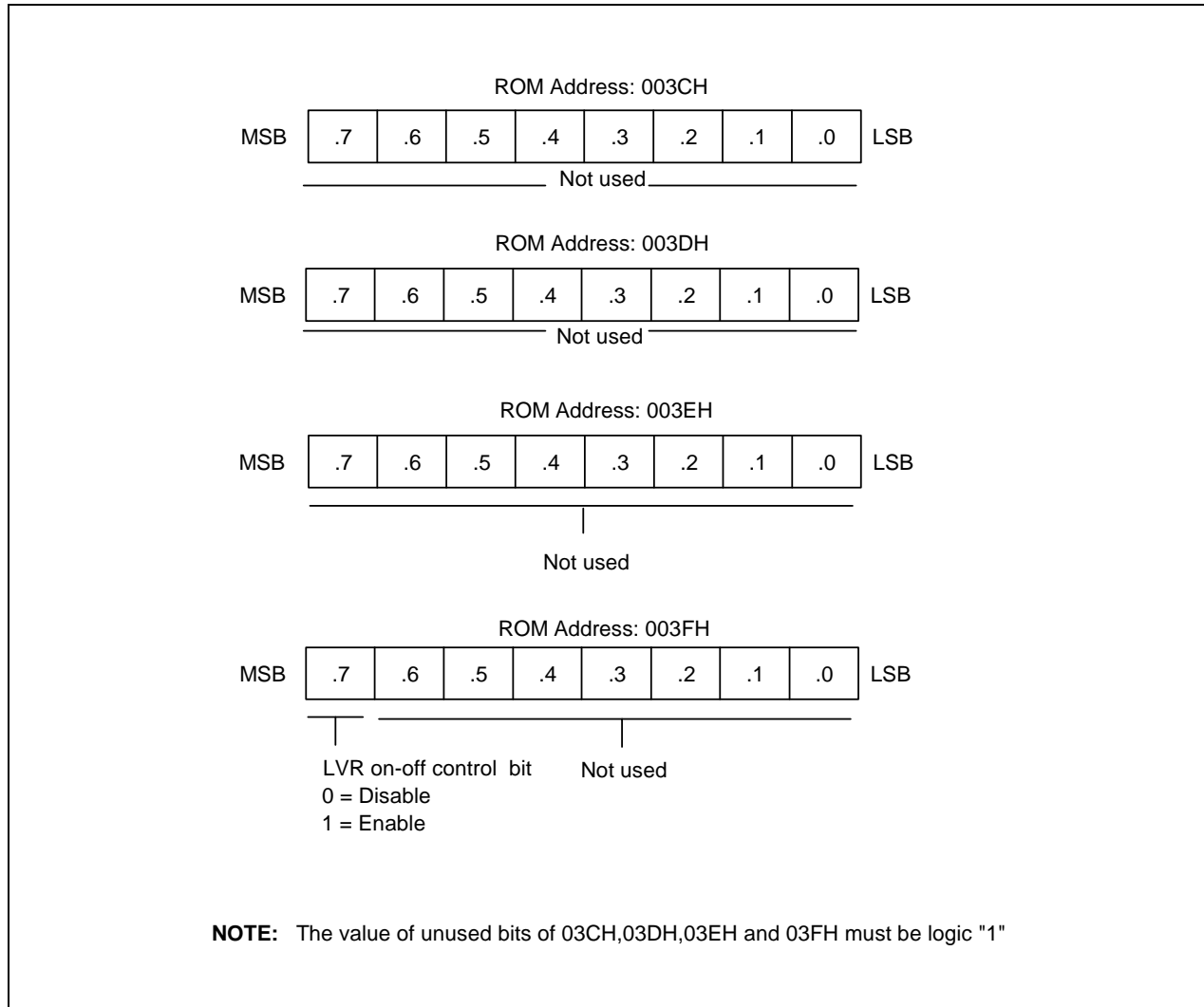


Figure 2-2. Smart Option

REGISTER ARCHITECTURE

In the S3C84H5/F84H5 implementation, the upper 64-byte area of register files is expanded two 64-byte areas, called *set 1* and *set 2*. The upper 32-byte area of set 1 is further expanded two 32-byte register banks (bank 0 and bank 1), and the lower 32-byte area is a single 32-byte common area.

In case of S3C84H5/F84H5 the total number of addressable 8-bit registers is 334. Of these 334 registers, 13 bytes are for CPU and system control registers, 49 bytes are for peripheral control and data registers, 16 bytes are used as a shared working registers and 256 registers are for general-purpose use.

You can always address set 1 register location, regardless of which of the 2 register pages is currently selected. The set 1 locations, however, can only be addressed using direct addressing modes.

The extension of register space into separately addressable areas (sets, banks, and pages) is supported by various addressing mode restrictions, the select bank instructions, SB0 and SB1, and the register page pointer (PP).

Specific register types and the area (in bytes) that they occupy in the register file are summarized in Table 2–1.

Table 2-1. S3C84H5/F84H5 Register Type Summary

Register Type	Number of Bytes
General-purpose registers (including 16-byte common working register area, expanded 2 separately addressable register pages (1 Page occupies 172-byte prime register area and the 64-byte set 2 area))	272
CPU and system control registers	13
Mapped clock, peripheral, I/O control, and data registers	49
Total Addressable Bytes	334

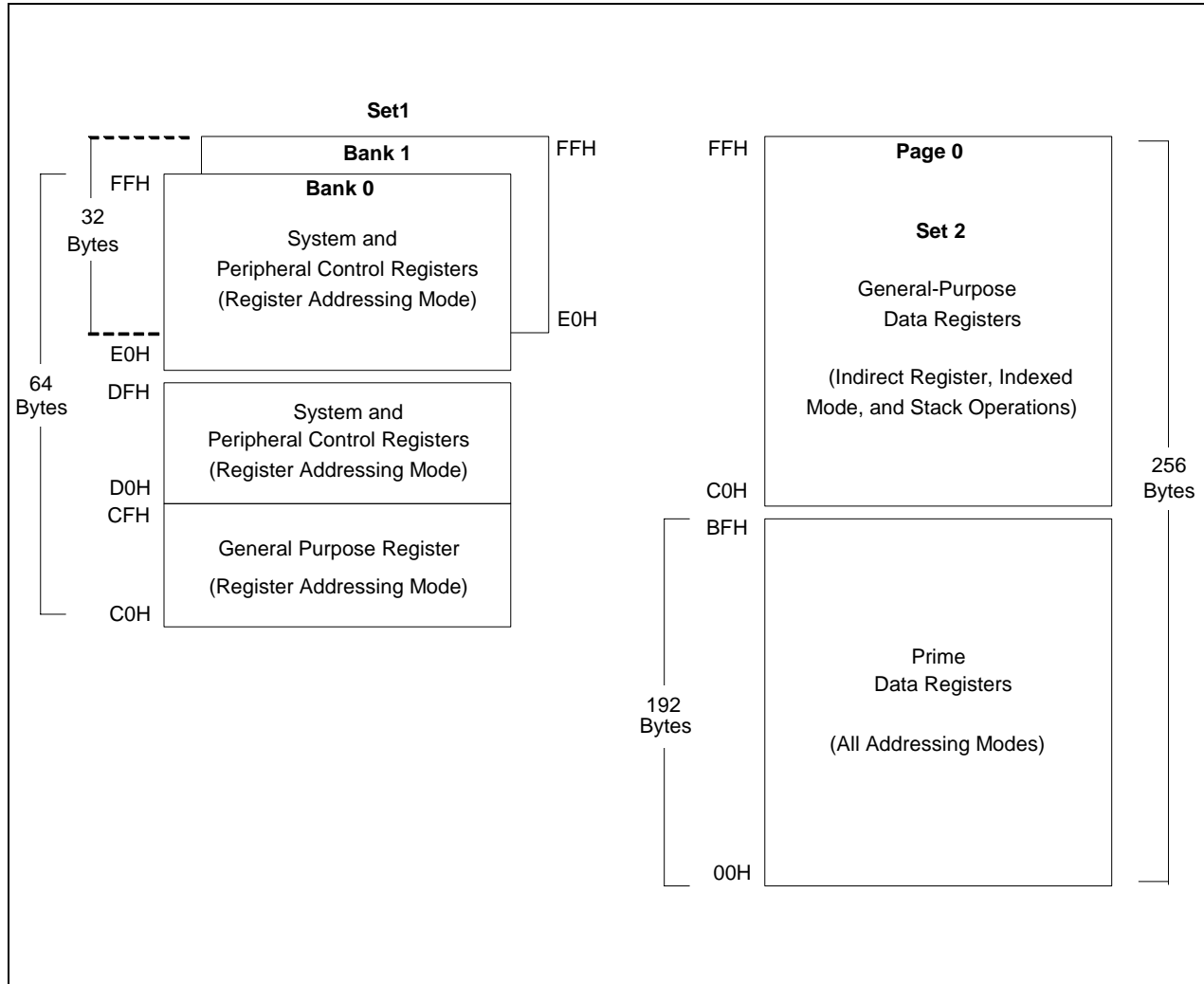


Figure 2-3. Internal Register File Organization

REGISTER PAGE POINTER (PP)

The S3C8-series architecture supports the logical expansion of the physical 256-byte internal register file (using an 8-bit data bus) into as many as 2 separately addressable register pages. Page addressing is controlled by the register page pointer (PP, DFH). In the S3C84H5/F84H5 microcontroller, a paged register file expansion is implemented for data registers, and the register page pointer must be changed to address other pages.

After a reset, the page pointer's source value (lower nibble) and the destination value (upper nibble) are always "0000", automatically selecting page 0 as the source and destination page for register addressing.

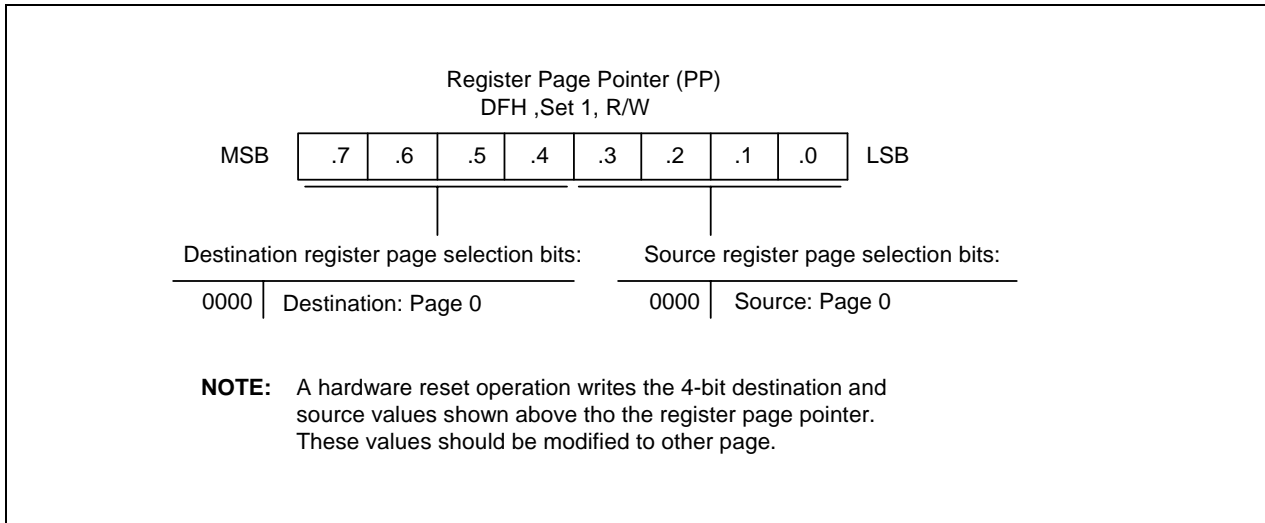


Figure 2-4. Register Page Pointer (PP)

 **Programming Tip — Using the Page Pointer for RAM clear**

```
RAMCL0: LD      PP,#00H      ; Destination ← 0, Source ← 0
          SRP      #0C0H
          LD      R0,#0FFH  ; Page 0 RAM clear starts
          CLR     @R0
          DJNZ   R0,RAMCL0
          CLR     @R0      ; R0 = 00H

RAMCL1: LD      PP,#10H    ; Destination ← 1, Source ← 0
          LD      R0,#0FFH  ; Page 1 RAM clear starts
          CLR     @R0
          DJNZ   R0,RAMCL1
          CLR     @R0      ; R0 = 00H
```


REGISTER SET 1

The term *set 1* refers to the upper 64 bytes of the register file, locations C0H–FFH.

The upper 32-byte area of this 64-byte space (E0H–FFH) is expanded two 32-byte register banks, *bank 0* and *bank 1*. The set register bank instructions, SB0 or SB1, are used to address one bank or the other. A hardware reset operation always selects bank 0 addressing.

The upper two 32-byte areas (bank 0 and bank 1) of set 1 (E0H–FFH) contains 64 mapped system and peripheral control registers. The lower 32-byte area contains 16 system registers (D0H–DFH) and a 16-byte common working register area (C0H–CFH). You can use the common working register area as a “scratch” area for data operations being performed in other areas of the register file.

Registers in set 1 locations are directly accessible at all times using Register addressing mode. The 16-byte working register area can only be accessed using working register addressing (For more information about working register addressing, please refer to Chapter 3, “Addressing Modes.”)

REGISTER SET 2

The same 64-byte physical space that is used for set 1 locations C0H–FFH is logically duplicated to add another 64 bytes of register space. This expanded area of the register file is called set 2. For S3C84H5/ F84H5, the set 2 address range (C0H–FFH) is accessible on pages 0-1.

The logical division of set 1 and set 2 is maintained by means of addressing mode restrictions. You can use only Register addressing mode to access set 1 locations. In order to access registers in set 2, you must use Register Indirect addressing mode or Indexed addressing mode.

The set 2 register area is commonly used for stack operations.

PRIME REGISTER SPACE

The lower 192 bytes (00H–BFH) of the S3C84H5/ F84H5's a 256-byte register pages is called *prime register area*. Prime registers can be accessed using any of the seven addressing modes (see Chapter 3, "Addressing Modes.")

The prime register area on page 0 is immediately addressable following a reset. In order to address prime registers on pages, you must set the register page pointer (PP) to the appropriate source and destination values.

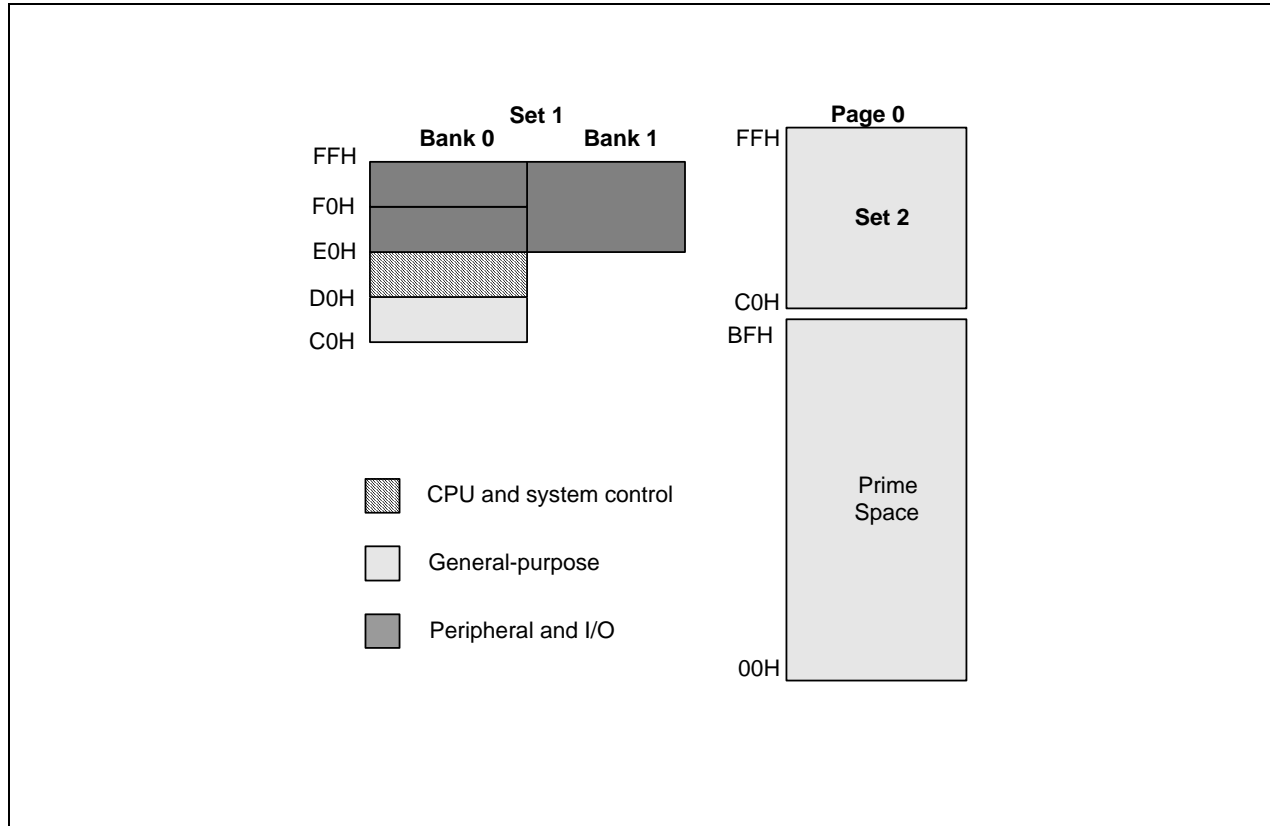


Figure 2-5. Set 1, Set 2, Prime Area Register

WORKING REGISTERS

Instructions can access specific 8-bit registers or 16-bit register pairs using either 4-bit or 8-bit address fields. When 4-bit working register addressing is used, the 256-byte register file can be seen by the programmer as one that consists of 32 8-byte register groups or "slices." Each slice comprises of eight 8-bit registers.

Using the two 8-bit register pointers, RP1 and RP0, two working register slices can be selected at any one time to form a 16-byte working register block. Using the register pointers, you can move this 16-byte register block anywhere in the addressable register file, except for the set 2 area.

The terms slice and block are used in this manual to help you visualize the size and relative locations of selected working register spaces:

- One working register *slice* is 8 bytes (eight 8-bit working registers, R0–R7 or R8–R15)
- One working register *block* is 16 bytes (sixteen 8-bit working registers, R0–R15)

All the registers in an 8-byte working register slice have the same binary value for their five most significant address bits. This makes it possible for each register pointer to point to one of the 24 slices in the register file other than set 2. The base addresses for the two selected 8-byte register slices are contained in register pointers RP0 and RP1.

After a reset, RP0 and RP1 always point to the 16-byte common area in set 1 (C0H–CFH).

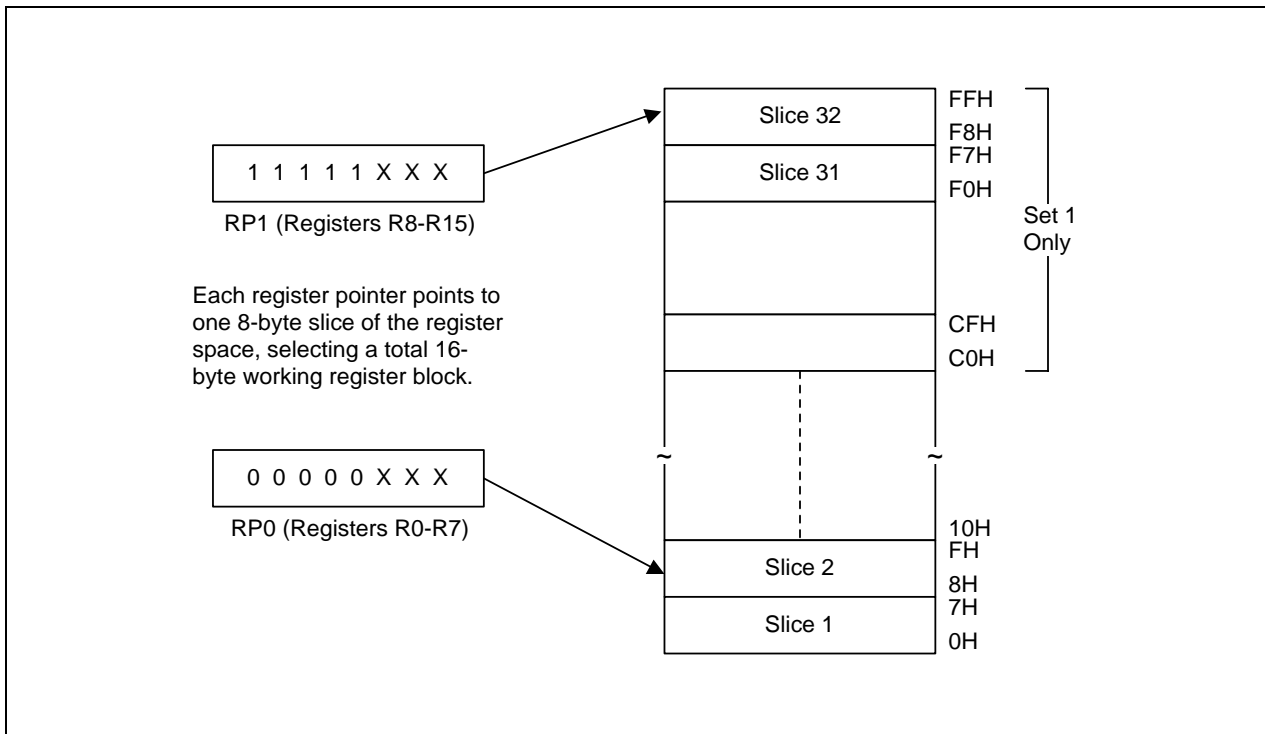


Figure 2-6. 8-Byte Working Register Areas (Slices)

USING THE REGISTER POINTERS

Register pointers RP0 and RP1, mapped to addresses D6H and D7H in set 1, are used to select two movable 8-byte working register slices in the register file. After a reset, RP# point to the working register common area: RP0 points to addresses C0H–C7H, and RP1 points to addresses C8H–CFH.

To change a register pointer value, you load a new value to RP0 and/or RP1 using an SRP or LD instruction. (see Figures 2-6 and 2-7).

With working register addressing, you can only access those two 8-bit slices of the register file that are currently pointed to by RP0 and RP1. You cannot, however, use the register pointers to select a working register space in set 2, C0H–FFH, because these locations can be accessed only using the Indirect Register or Indexed addressing modes.

The selected 16-byte working register block usually consists of two contiguous 8-byte slices. As a general programming guideline, it is recommended that RP0 point to the "lower" slice and RP1 point to the "upper" slice (see Figure 2-6). In some cases, it may be necessary to define working register areas in different (non-contiguous) areas of the register file. In Figure 2-7, RP0 points to the "upper" slice and RP1 to the "lower" slice.

Because a register pointer can point to either of the two 8-byte slices in the working register block, you can flexibly define the working register area to support program requirements.

PROGRAMMING TIP — Setting the Register Pointers

SRP	#70H	; RP0 ← 70H, RP1 ← 78H
SRP1	#48H	; RP0 ← no change, RP1 ← 48H,
SRP0	#0A0H	; RP0 ← 0A0H, RP1 ← no change
CLR	RP0	; RP0 ← 00H, RP1 ← no change
LD	RP1,#0F8H	; RP0 ← no change, RP1 ← 0F8H

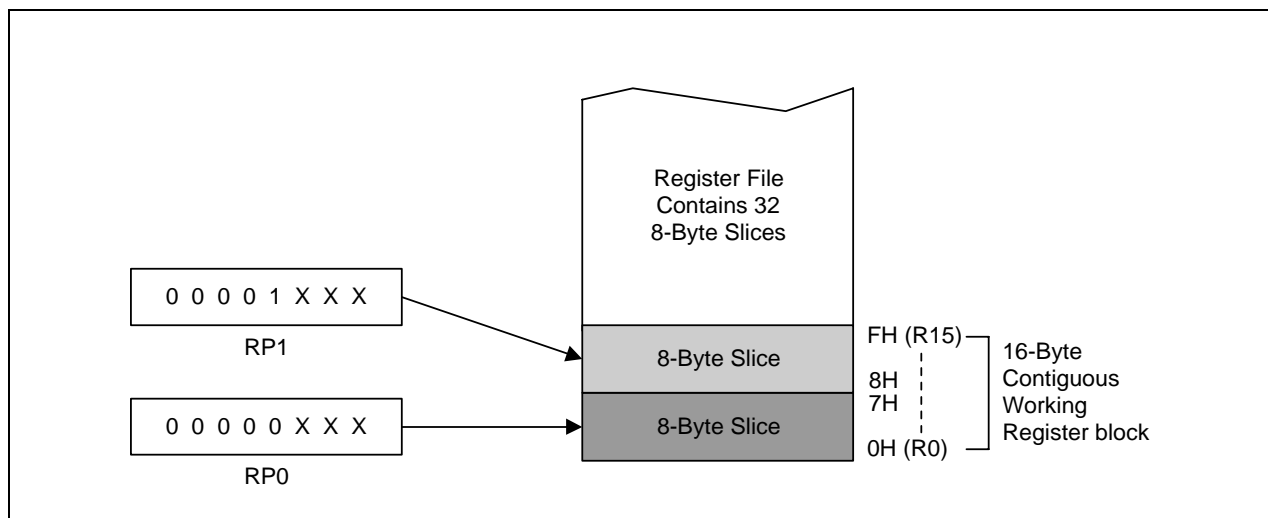


Figure 2-7. Contiguous 16-Byte Working Register Block

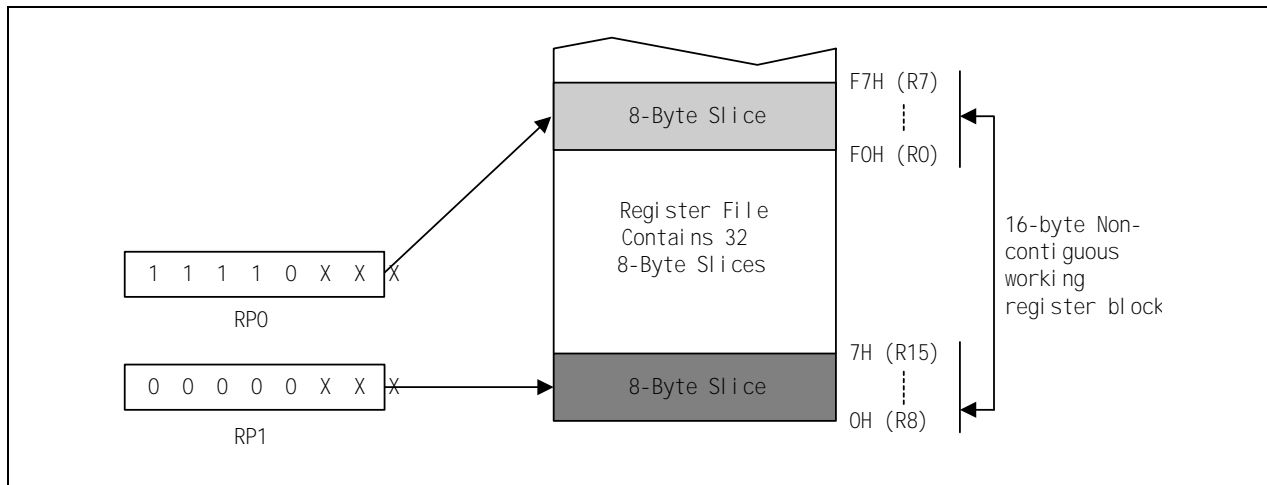


Figure 2-8. Non-Contiguous 16-Byte Working Register Block

PROGRAMMING TIP — Using the RPs to Calculate the Sum of a Series of Registers

Calculate the sum of registers 80H–85H using the register pointer. The register addresses from 80H through 85H contain the values 10H, 11H, 12H, 13H, 14H, and 15H, respectively:

```

SRP0    #80H           ; RP0 ← 80H
ADD     R0,R1          ; R0 ← R0 + R1
ADC     R0,R2          ; R0 ← R0 + R2 + C
ADC     R0,R3          ; R0 ← R0 + R3 + C
ADC     R0,R4          ; R0 ← R0 + R4 + C
ADC     R0,R5          ; R0 ← R0 + R5 + C

```

The sum of these six registers, 6FH, is located in the register R0 (80H). The instruction string used in this example takes 12 bytes of instruction code and its execution time is 36 cycles. If the register pointer is not used to calculate the sum of these registers, the following instruction sequence would have to be used:

```

ADD     80H,81H        ; 80H ← (80H) + (81H)
ADC     80H,82H        ; 80H ← (80H) + (82H) + C
ADC     80H,83H        ; 80H ← (80H) + (83H) + C
ADC     80H,84H        ; 80H ← (80H) + (84H) + C
ADC     80H,85H        ; 80H ← (80H) + (85H) + C

```

Now, the sum of the six registers is also located in register 80H. However, this instruction string takes 15 bytes of instruction code rather than 12 bytes, and its execution time is 50 cycles rather than 36 cycles.

REGISTER ADDRESSING

The S3C8-series register architecture provides an efficient method of working register addressing that takes full advantage of shorter instruction formats to reduce execution time.

With Register (R) addressing mode, in which the operand value is the content of a specific register or register pair, you can access any location in the register file except for set 2. With working register addressing, you use a register pointer to specify an 8-byte working register space in the register file and an 8-bit register within that space.

Registers are addressed either as a single 8-bit register or as a paired 16-bit register space. In a 16-bit register pair, the address of the first 8-bit register is always an even number and the address of the next register is always an odd number. The most significant byte of the 16-bit data is always stored in the even-numbered register, and the least significant byte is always stored in the next (+1) odd-numbered register.

Working register addressing differs from Register addressing as it uses a register pointer to identify a specific 8-byte working register space in the internal register file and a specific 8-bit register within that space.

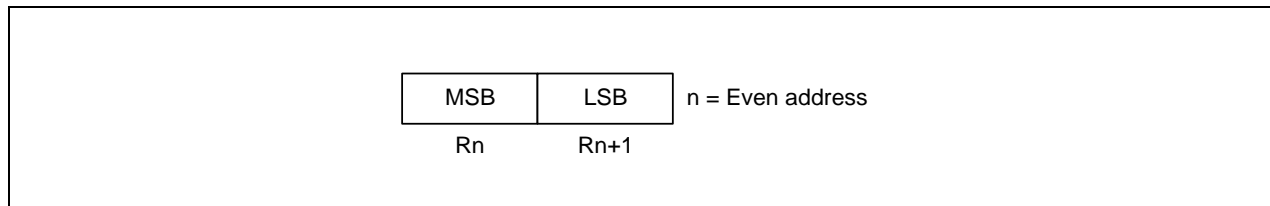


Figure 2-9. 16-Bit Register Pair

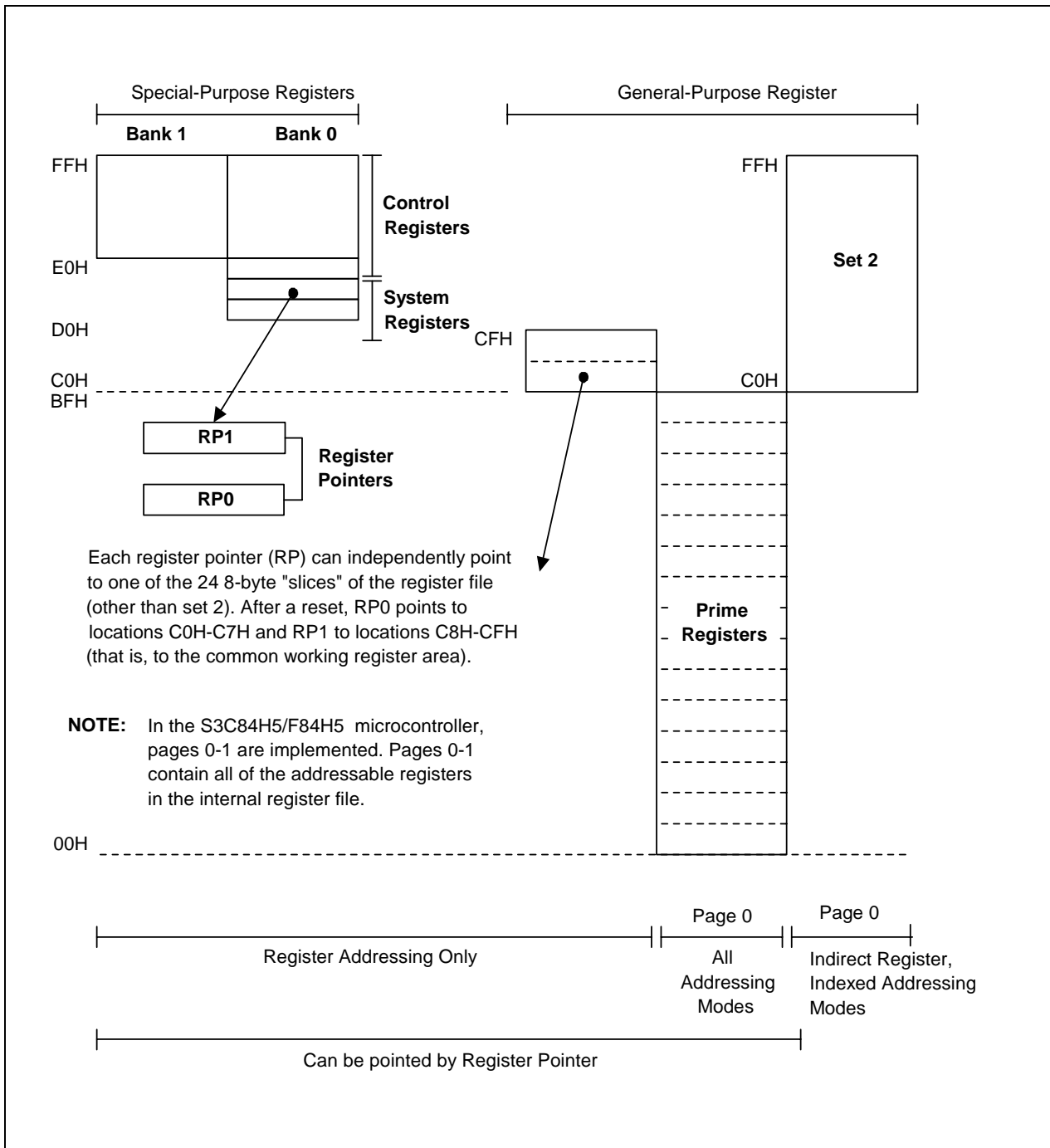


Figure 2-10. Register File Addressing

COMMON WORKING REGISTER AREA (C0H–CFH)

After a reset, register pointers RP0 and RP1 automatically select two 8-byte register slices in set 1, locations C0H–CFH, as the active 16-byte working register block:

RP0 → C0H–C7H

RP1 → C8H–CFH

This 16-byte address range is called *common area*. That is, locations in this area can be used as working registers by operations that address any location on any page in the register file. Typically, these working registers serve as temporary buffers for data operations between different pages.

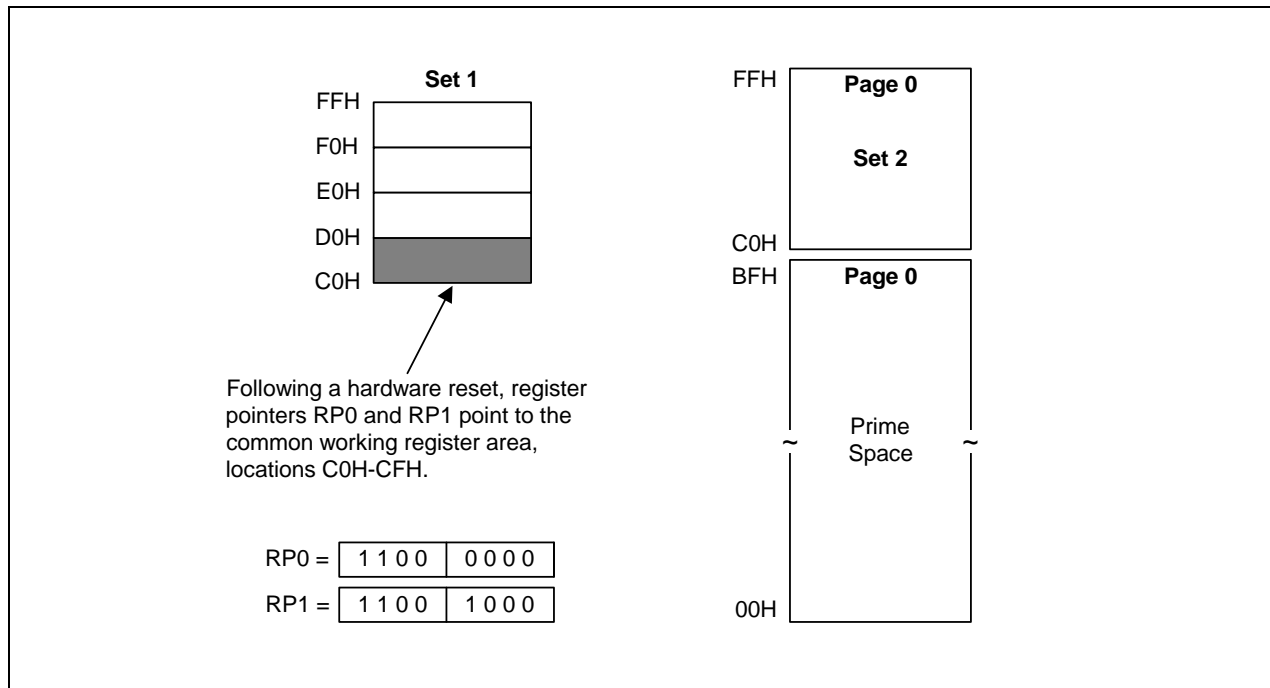


Figure 2-11. Common Working Register Area

PROGRAMMING TIP — Addressing the Common Working Register Area

As the following examples show, you should access working registers in the common area, locations C0H–CFH, using working register addressing mode only.

Examples 1:

```
LD    0C2H,40H           ; Invalid addressing mode!
```

Use working register addressing instead:

```
SRP   #0C0H
LD    R2,40H           ; R2 (C2H) ← the value in location 40H
```

Example 2:

```
ADD   0C3H,#45H        ; Invalid addressing mode!
```

Use working register addressing instead:

```
SRP   #0C0H
ADD   R3,#45H          ; R3 (C3H) ← R3 + 45H
```

4-BIT WORKING REGISTER ADDRESSING

Each register pointer defines a movable 8-byte slice of working register space. The address information stored in a register pointer serves as an addressing "window" that makes it possible for instructions to access working registers very efficiently using short 4-bit addresses. When an instruction addresses a location in the selected working register area, the address bits are concatenated in the following way to form a complete 8-bit address:

- The high-order bit of the 4-bit address selects one of the register pointers ("0" selects RP0, "1" selects RP1).
- The five high-order bits in the register pointer select an 8-byte slice of the register space.
- The three low-order bits of the 4-bit address select one of the eight registers in the slice.

As shown in Figure 2-11, the result of this operation is that the five high-order bits from the register pointer are concatenated with the three low-order bits from the instruction address to form the complete address. As long as the address stored in the register pointer remains unchanged, the three bits from the address will always point to an address in the same 8-byte register slice.

Figure 2-12 shows a typical example of 4-bit working register addressing. The high-order bit of the instruction "INC R6" is "0", which selects RP0. The five high-order bits stored in RP0 (01110B) are concatenated with the three low-order bits of the instruction's 4-bit address (110B) to produce the register address 76H (01110110B).

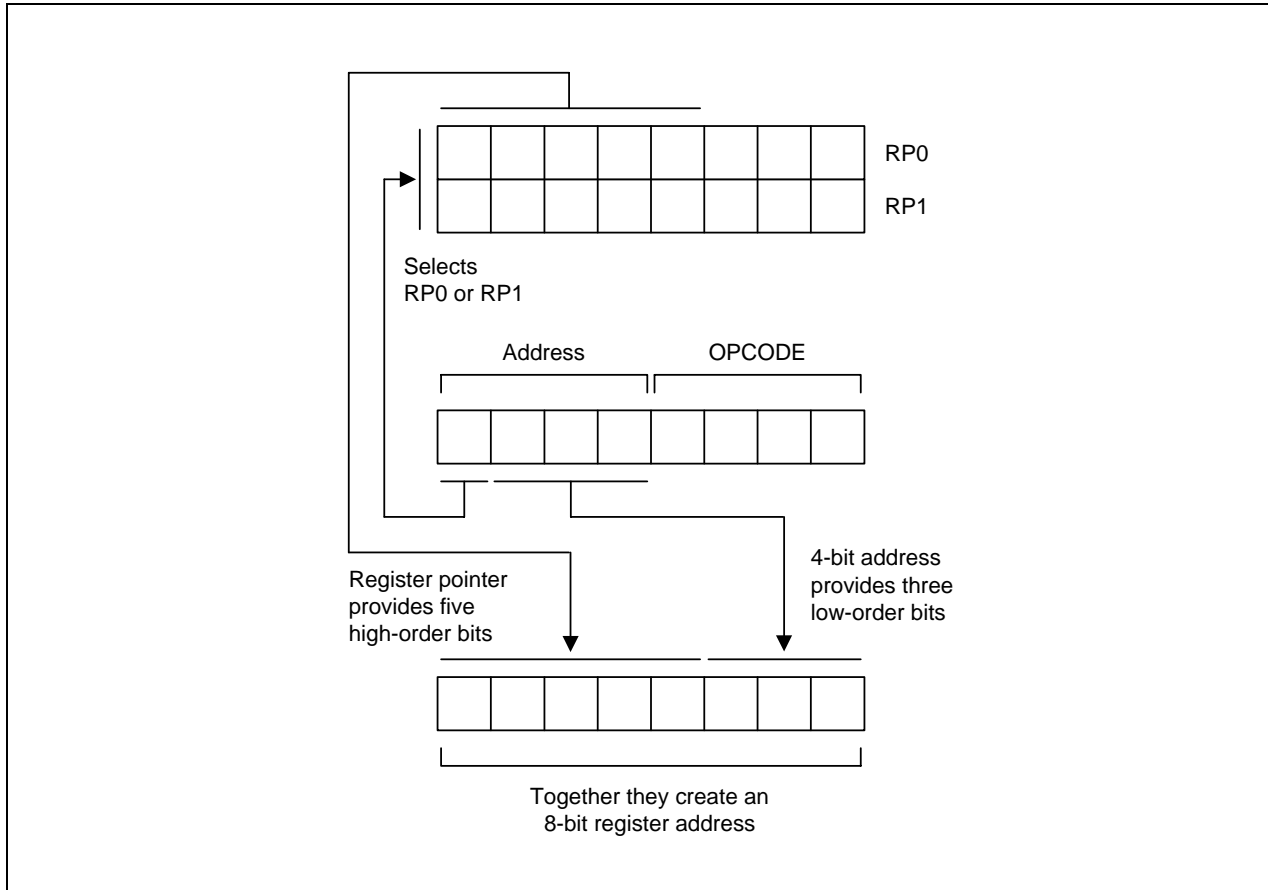


Figure 2-12. 4-Bit Working Register Addressing

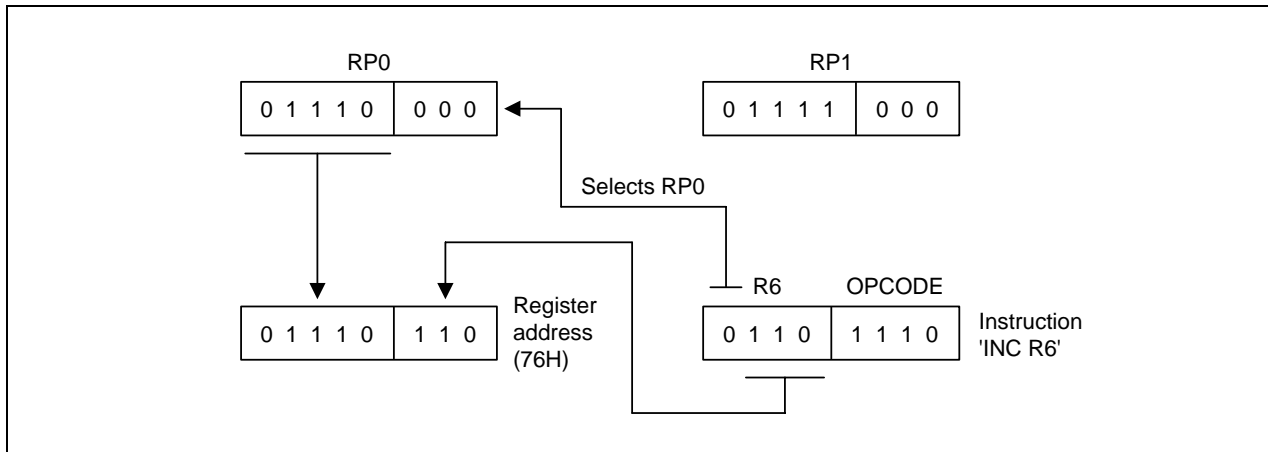


Figure 2-13. 4-Bit Working Register Addressing Example

8-BIT WORKING REGISTER ADDRESSING

You can also use 8-bit working register addressing to access registers in a selected working register area. To initiate 8-bit working register addressing, the upper four bits of the instruction address must contain the value "1100B." This 4-bit value (1100B) indicates that the remaining four bits have the same effect as 4-bit working register addressing.

As shown in Figure 2-13, the lower nibble of the 8-bit address is concatenated in much the same way as for 4-bit addressing. Bit 3 selects either RP0 or RP1, which then supplies the five high-order bits of the final address. The three low-order bits of the complete address are provided by the original instruction.

Figure 2-14 shows an example of 8-bit working register addressing. The four high-order bits of the instruction address (1100B) specify 8-bit working register addressing. Bit 3 ("1") selects RP1 and the five high-order bits in RP1 (10101B) become the five high-order bits of the register address. The three low-order bits of the register address (011) are provided by the three low-order bits of the 8-bit instruction address. The five-address bits from RP1 and the three address bits from the instruction are concatenated to form the complete register address, 0ABH (10101011B).

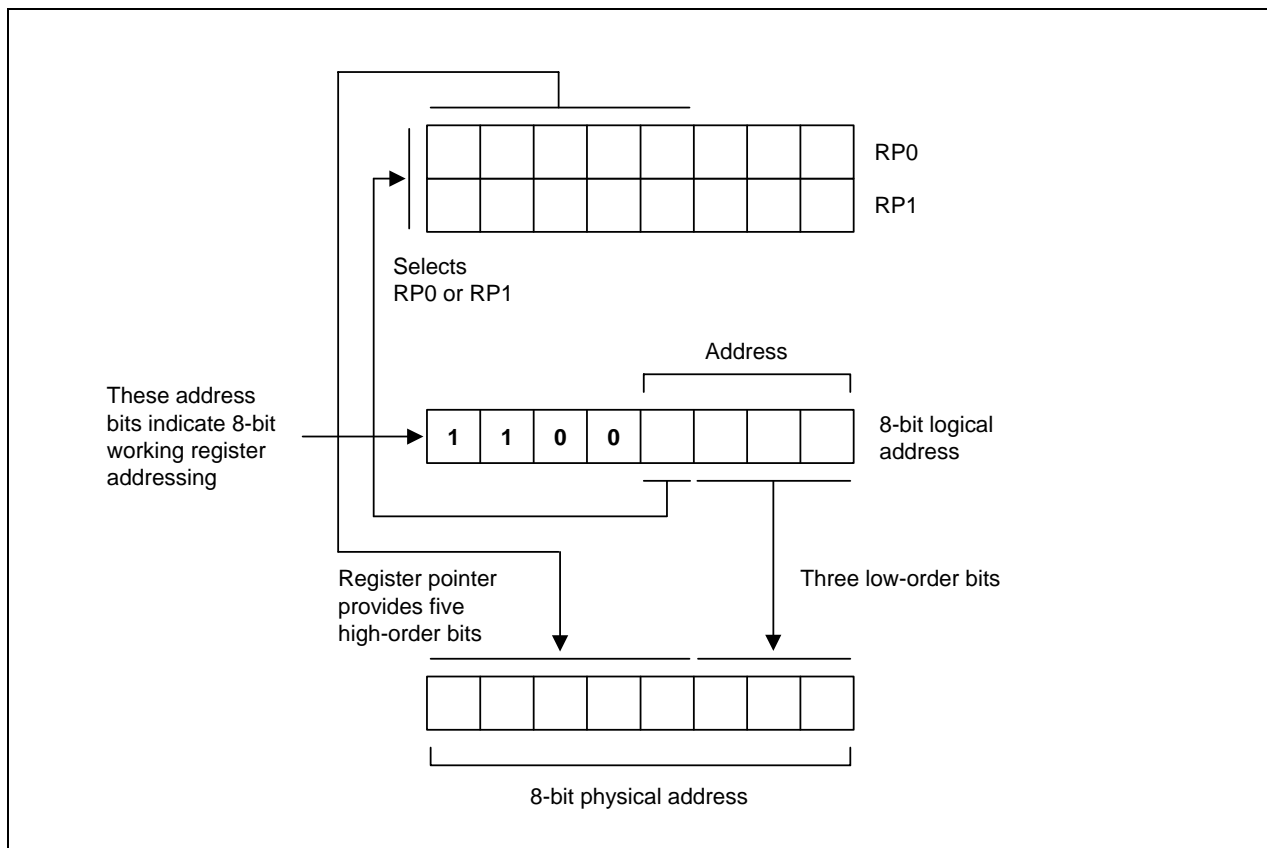


Figure 2-14. 8-Bit Working Register Addressing

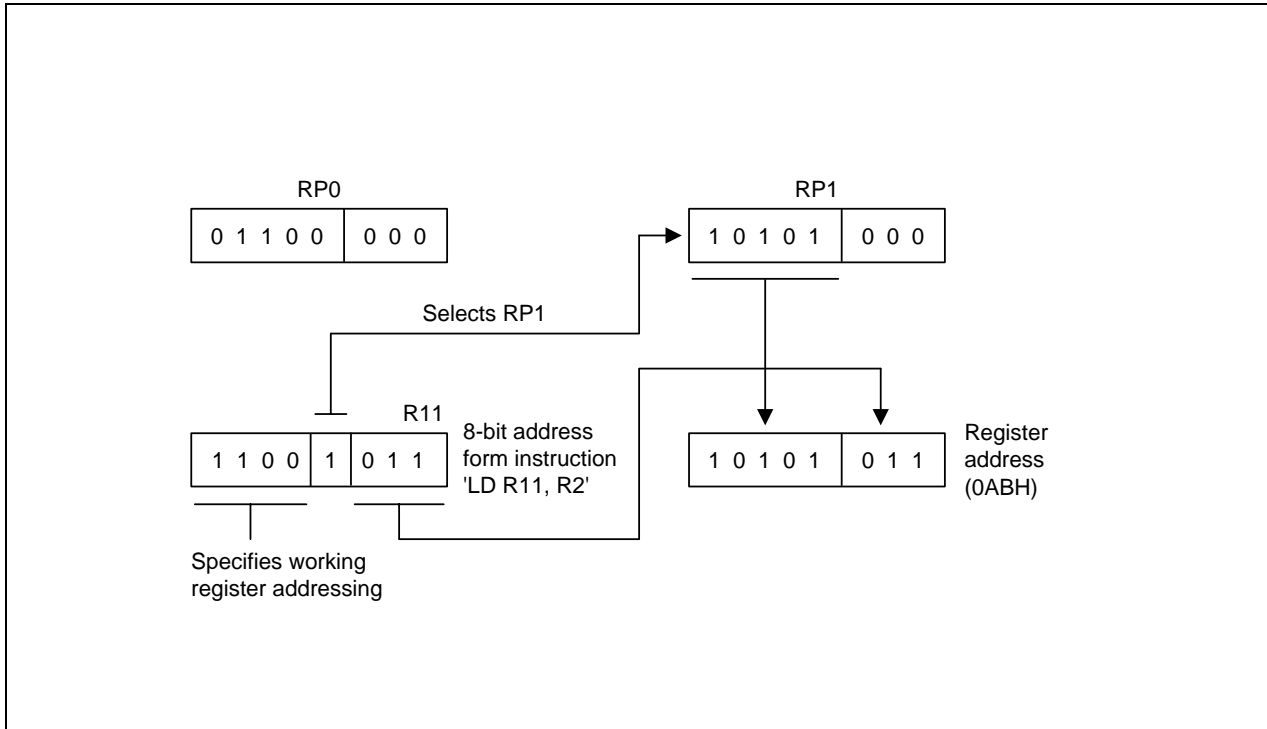


Figure 2-15. 8-Bit Working Register Addressing Example

SYSTEM AND USER STACK

The S3C8-series microcontrollers use the system stack for data storage, subroutine calls and returns. The PUSH and POP instructions are used to control system stack operations. The S3C84H5/F84H5 architecture supports stack operations in the internal register file.

Stack Operations

Return addresses for procedure calls, interrupts, and data are stored on the stack. The contents of the PC are saved to stack by a CALL instruction and restored by the RET instruction. When an interrupt occurs, the contents of the PC and the FLAGS register are pushed to the stack. The IRET instruction then pops these values back to their original locations. The stack address value is always decreased by one before a push operation and increased by one *after* a pop operation. The stack pointer (SP) always points to the stack frame stored on the top of the stack, as shown in Figure 2-15.

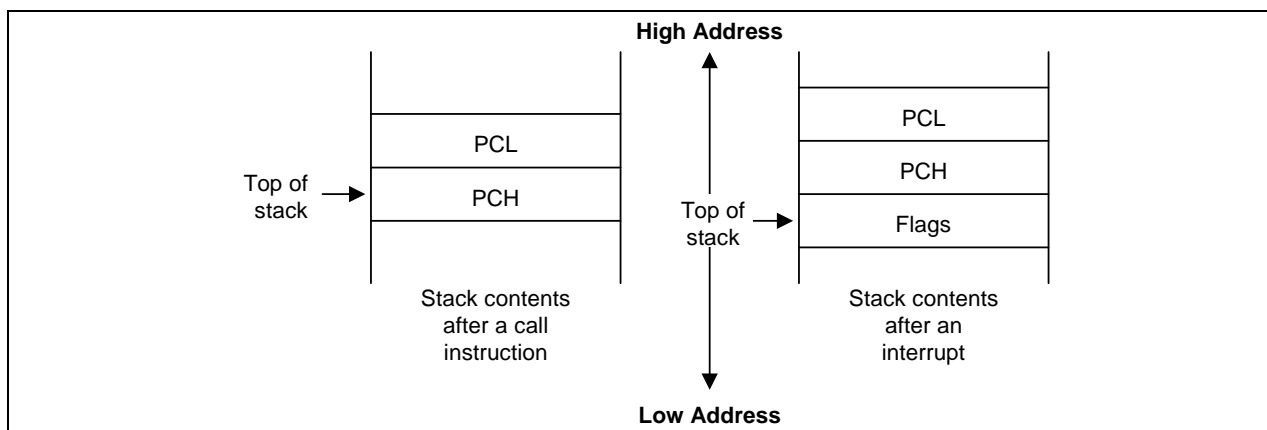


Figure 2-16. Stack Operations

User-Defined Stacks

You can freely define stacks in the internal register file as data storage locations. The instructions PUSHUI, PUSHUD, POPUI, and POPUD support user-defined stack operations.

Stack Pointers (SPL, SPH)

Register locations D8H and D9H contain the 16-bit stack pointer (SP) that is used for system stack operations. The most significant byte of the SP address, SP15–SP8, is stored in the SPH register (D8H), and the least significant byte, SP7–SP0, is stored in the SPL register (D9H). After a reset, the SP value is undetermined.

Because only internal memory space is implemented in the S3C84I5/C84I9/F84I9, the SPL must be initialized to an 8-bit value in the range 00H–FFH. The SPH register is not needed and can be used as a general-purpose register, if necessary.

When the SPL register contains the only stack pointer value (that is, when it points to a system stack in the register file), you can use the SPH register as a general-purpose data register. However, if an overflow or underflow condition occurs as a result of increasing or decreasing the stack address value in the SPL register during normal stack operations, the value in the SPL register will overflow (or underflow) to the SPH register, overwriting any other data that is currently stored there. To avoid overwriting data in the SPH register, you can initialize the SPL value to "FFH" instead of "00H".

 **PROGRAMMING TIP — Standard Stack Operations Using PUSH and POP**

The following example shows you how to perform stack operations in the internal register file using PUSH and POP instructions:

```

LD      SPL,#0FFH      ; SPL ← FFH
                        ; (Normally, the SPL is set to 0FFH by the initialization
                        ; routine)
.
.
.
PUSH   PP              ; Stack address 0FEH ← PP
PUSH   RP0             ; Stack address 0FDH ← RP0
PUSH   RP1             ; Stack address 0FCH ← RP1
PUSH   R3              ; Stack address 0FBH ← R3
.
.
.
POP    R3              ; R3 ← Stack address 0FBH
POP    RP1             ; RP1 ← Stack address 0FCH
POP    RP0             ; RP0 ← Stack address 0FDH
POP    PP              ; PP ← Stack address 0FEH

```

3 ADDRESSING MODES

OVERVIEW

Instructions that are stored in program memory are fetched for execution using the program counter. Instructions indicate the operation to be performed and the data to be operated on. Addressing mode is the method used to determine the location of the data operand. The operands specified in SAM8RC instructions may be condition codes, immediate data, or a location in the register file, program memory, or data memory.

The S3C8-series instruction set supports seven explicit addressing modes. Not all of these addressing modes are available for each instruction. The seven addressing modes and their symbols are:

- Register (R)
- Indirect Register (IR)
- Indexed (X)
- Direct Address (DA)
- Indirect Address (IA)
- Relative Address (RA)
- Immediate (IM)

REGISTER ADDRESSING MODE (R)

In Register addressing mode (R), the operand value is the content of a specified register or register pair (see Figure 3-1).

Working register addressing differs from Register addressing in that it uses a register pointer to specify an 8-byte working register space in the register file and an 8-bit register within that space (see Figure 3-2).

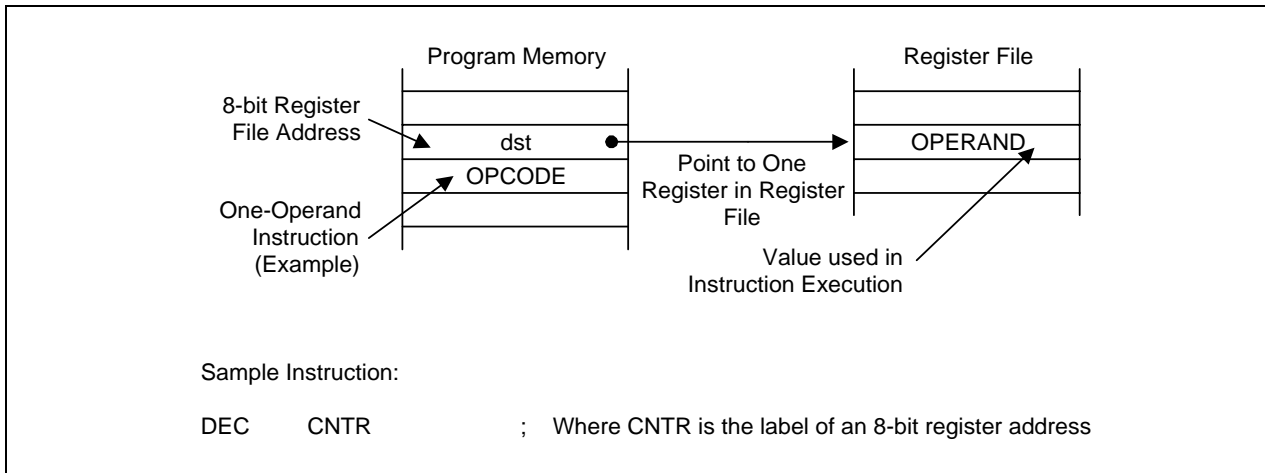


Figure 3-1. Register Addressing

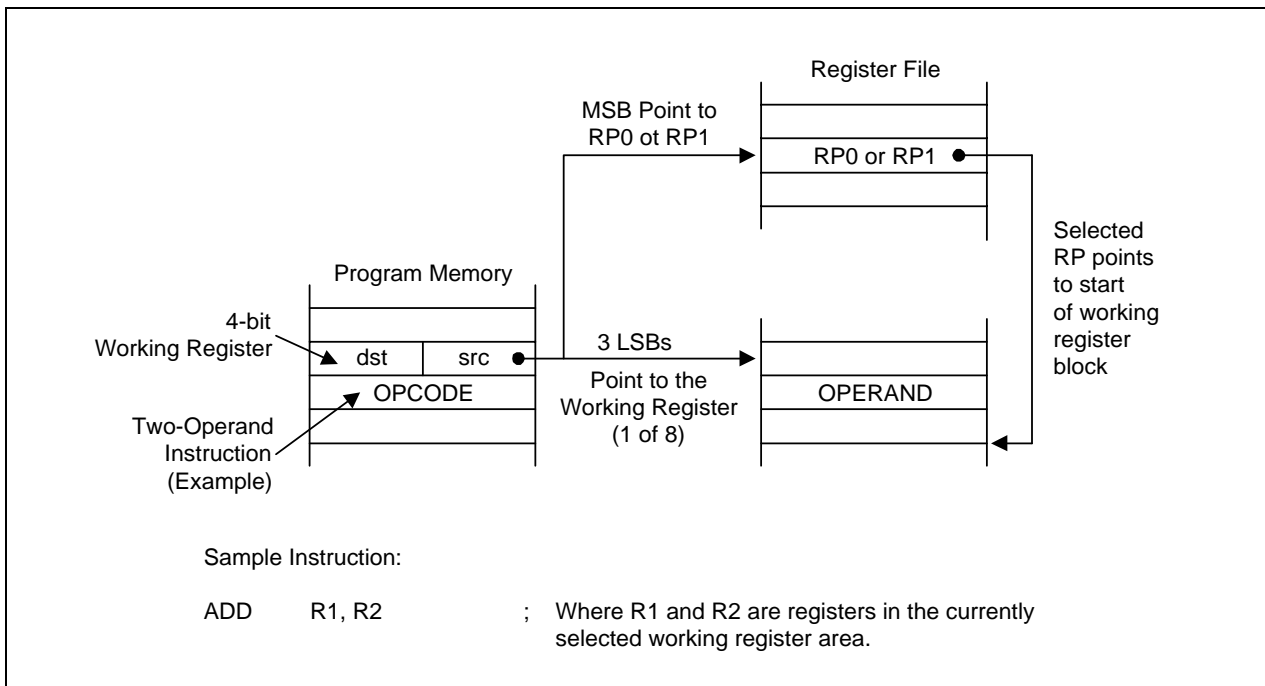


Figure 3-2. Working Register Addressing

INDIRECT REGISTER ADDRESSING MODE (IR)

In Indirect Register (IR) addressing mode, the content of the specified register or register pair is the address of the operand. Depending on the instruction used, the actual address may point to a register in the register file, to program memory (ROM), or to an external memory space (see Figures 3-3 through 3-6).

You can use any 8-bit register to indirectly address another register. Any 16-bit register pair can be used to indirectly address another memory location. Please note, however, that you cannot access locations C0H–FFH in set 1 using the Indirect Register addressing mode.

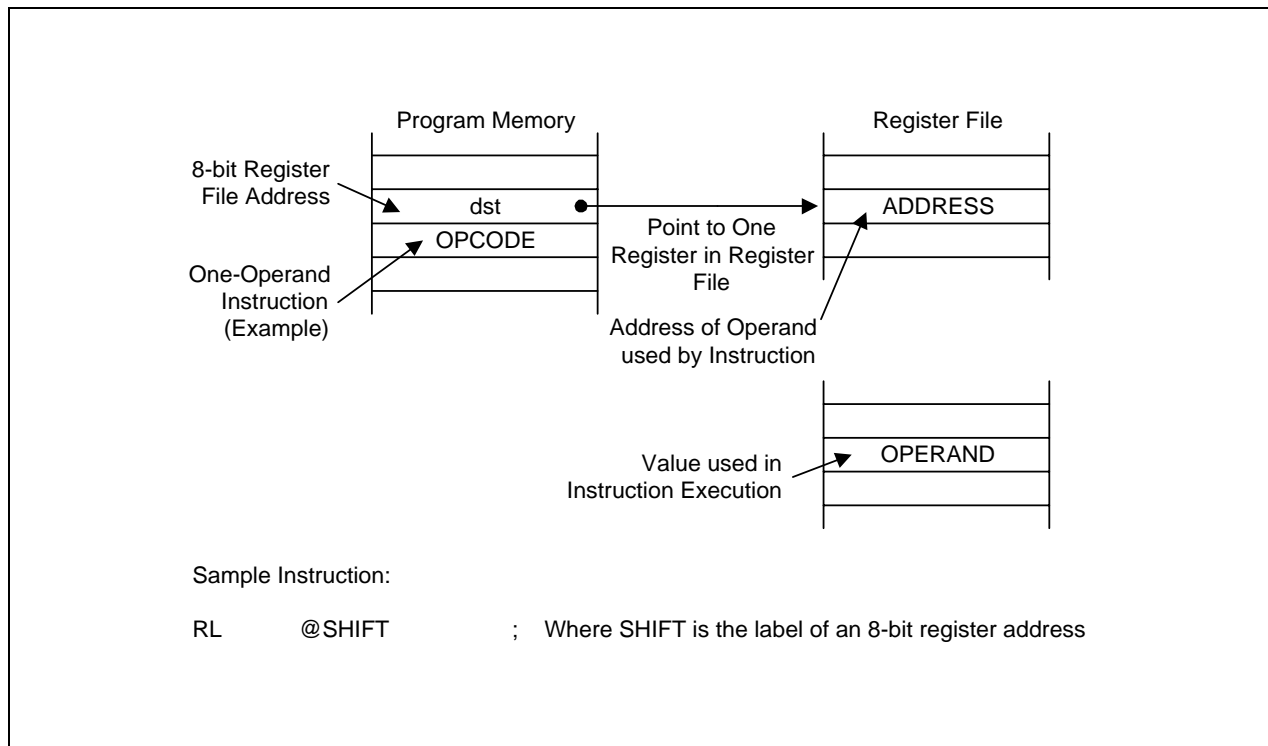


Figure 3-3. Indirect Register Addressing to Register File

INDIRECT REGISTER ADDRESSING MODE (Continued)

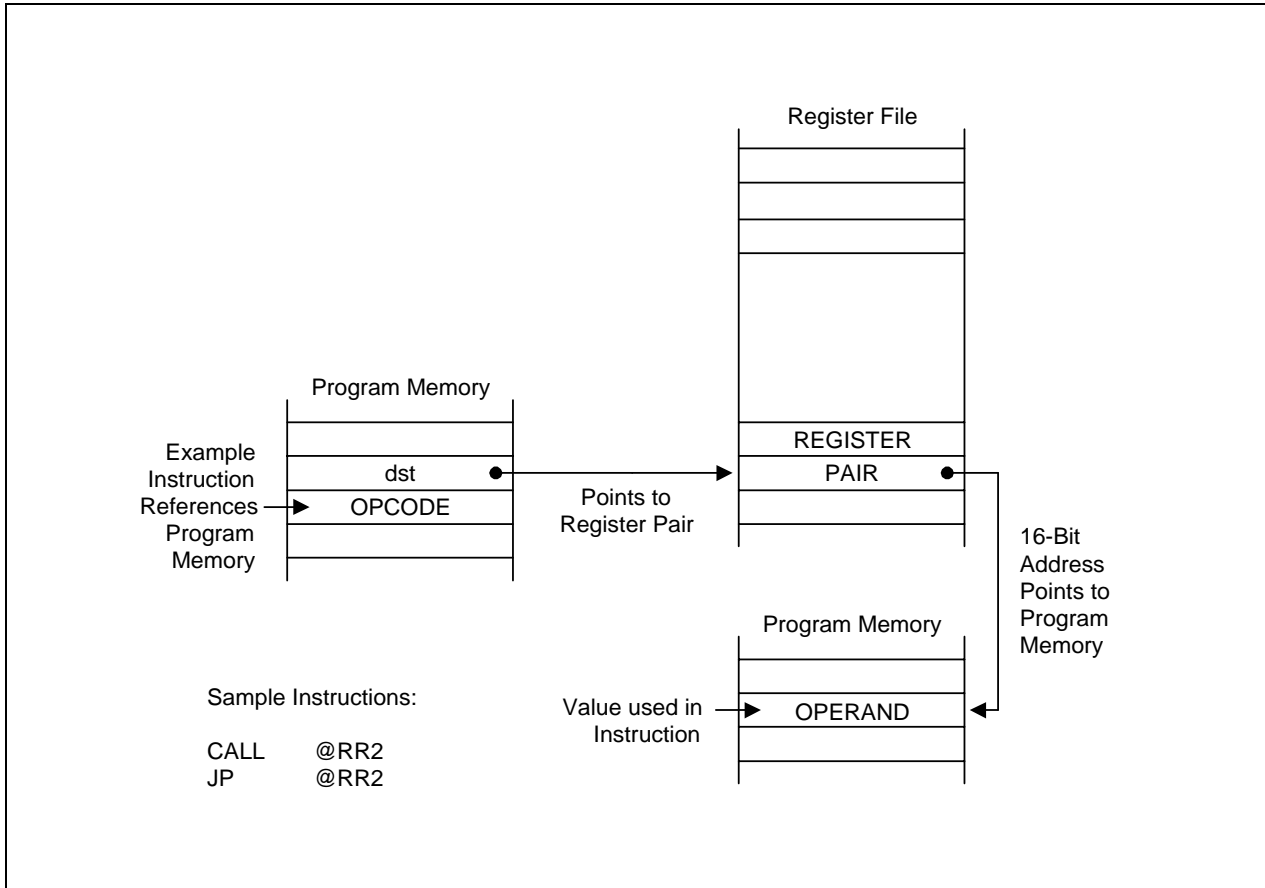


Figure 3-4. Indirect Register Addressing to Program Memory

INDIRECT REGISTER ADDRESSING MODE (Continued)

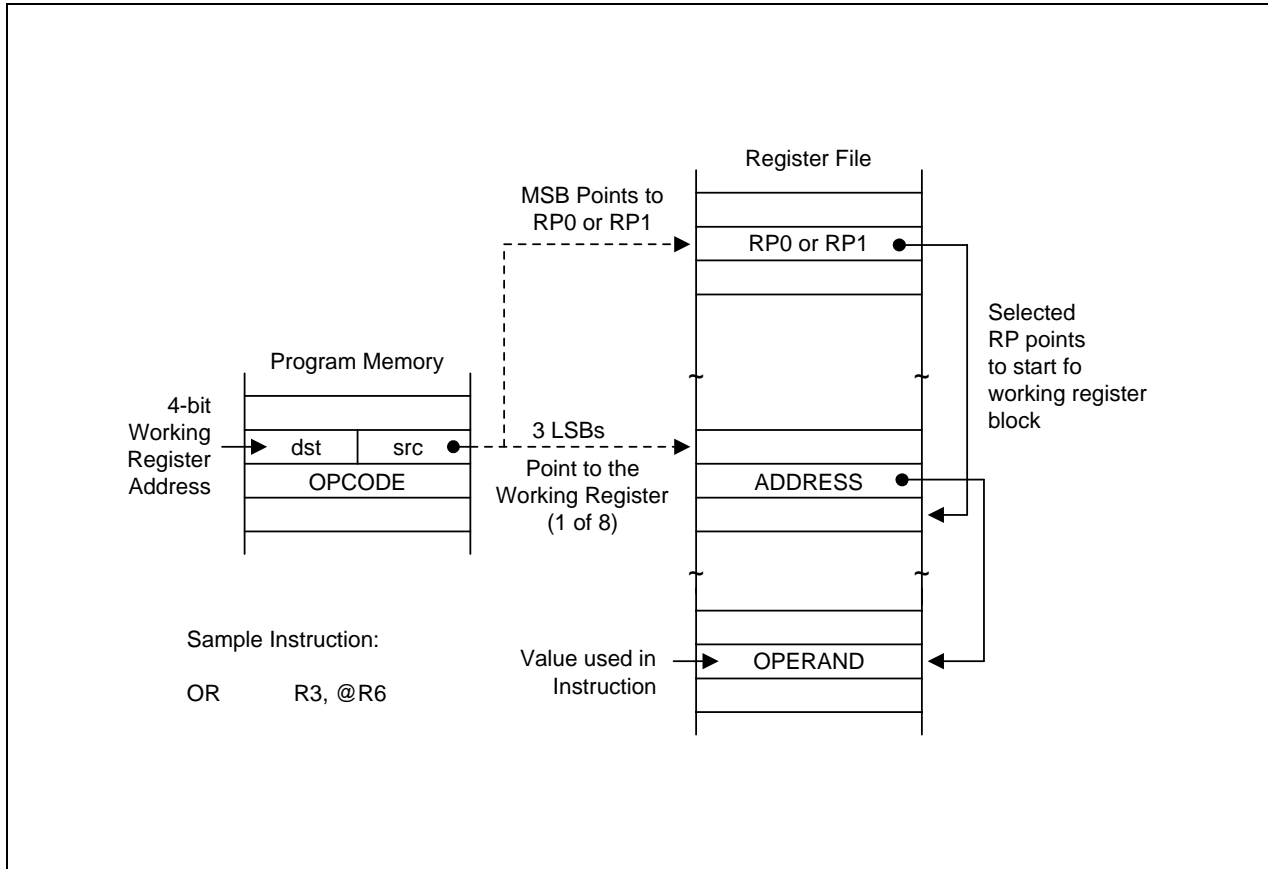


Figure 3-5. Indirect Working Register Addressing to Register File

INDIRECT REGISTER ADDRESSING MODE (Continued)

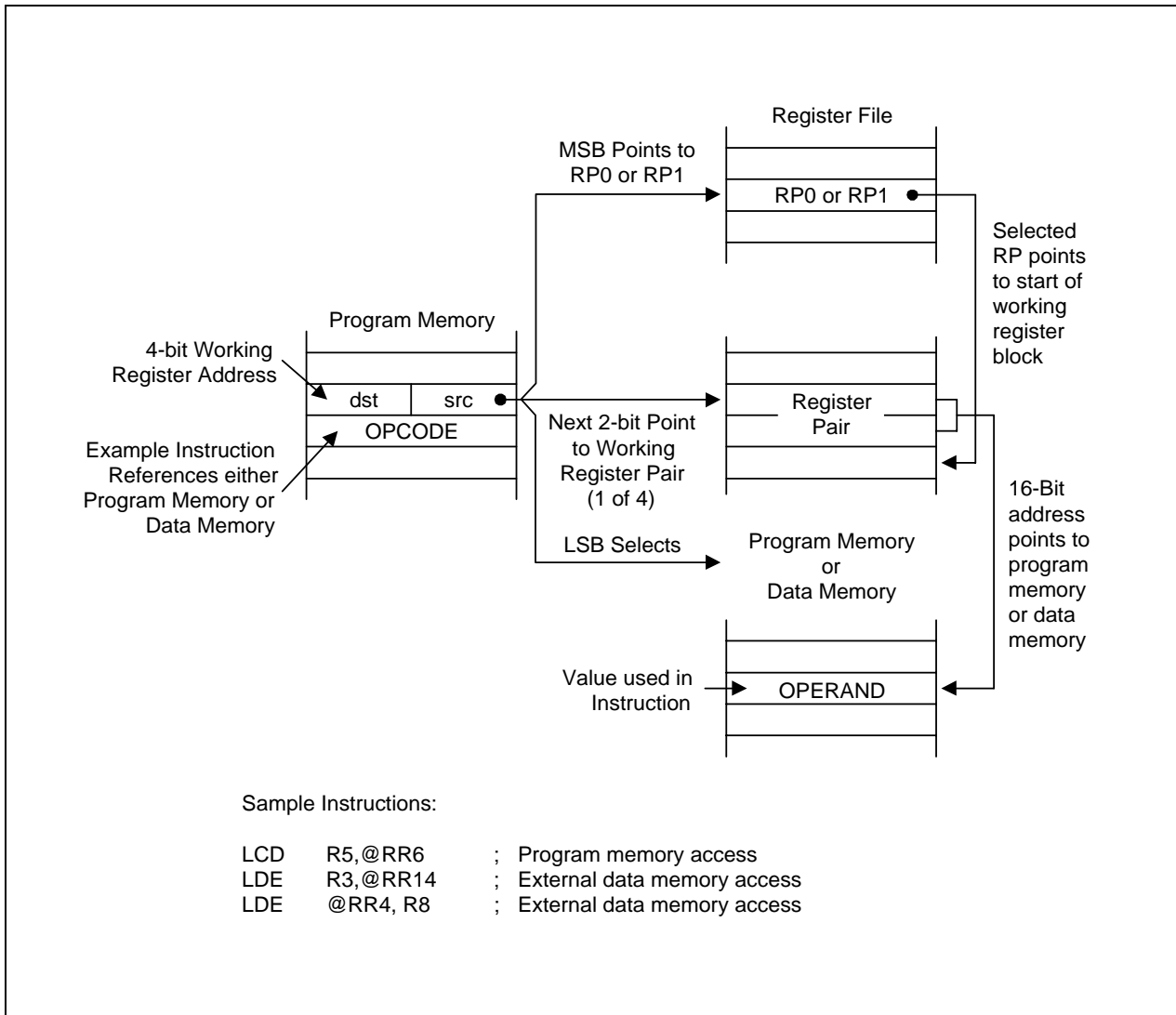


Figure 3-6. Indirect Working Register Addressing to Program or Data Memory

INDEXED ADDRESSING MODE (X)

Indexed (X) addressing mode adds an offset value to a base address during instruction execution in order to calculate the effective operand address (see Figure 3-7). You can use Indexed addressing mode to access locations in the internal register file or in external memory. Please note, however, that you cannot access locations C0H–FFH in set 1 using indexed addressing mode.

In short offset Indexed addressing mode, the 8-bit displacement is treated as a signed integer in the range -128 to $+127$. This applies to external memory accesses only (see Figure 3-8.)

For register file addressing, an 8-bit base address provided by the instruction is added to an 8-bit offset contained in a working register. For external memory accesses, the base address is stored in the working register pair designated in the instruction. The 8-bit or 16-bit offset given in the instruction is then added to that base address (see Figure 3-9).

The only instruction that supports indexed addressing mode for the internal register file is the Load instruction (LD). The LDC and LDE instructions support indexed addressing mode for internal program memory and for external data memory, when implemented.

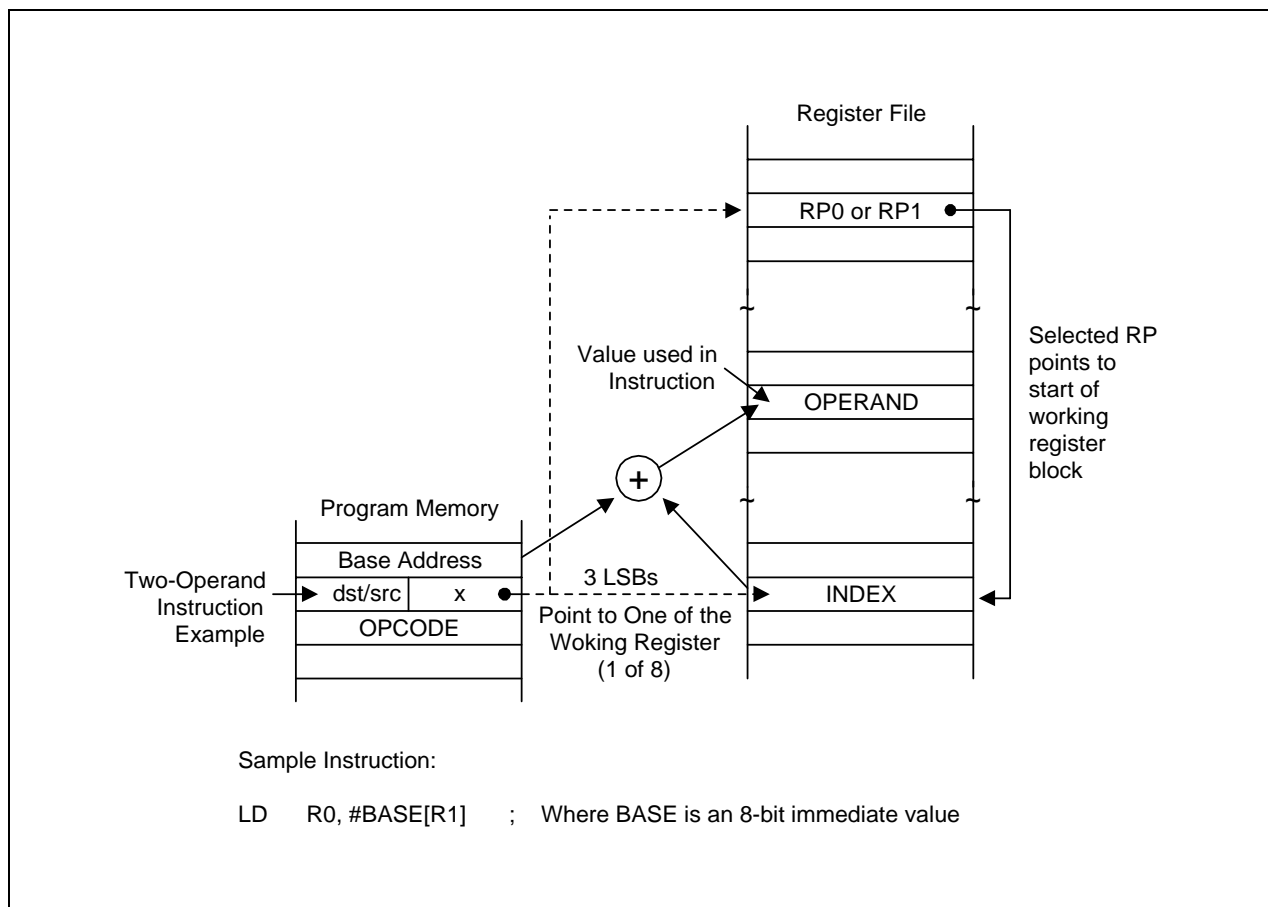


Figure 3-7. Indexed Addressing to Register File

INDEXED ADDRESSING MODE (Continued)

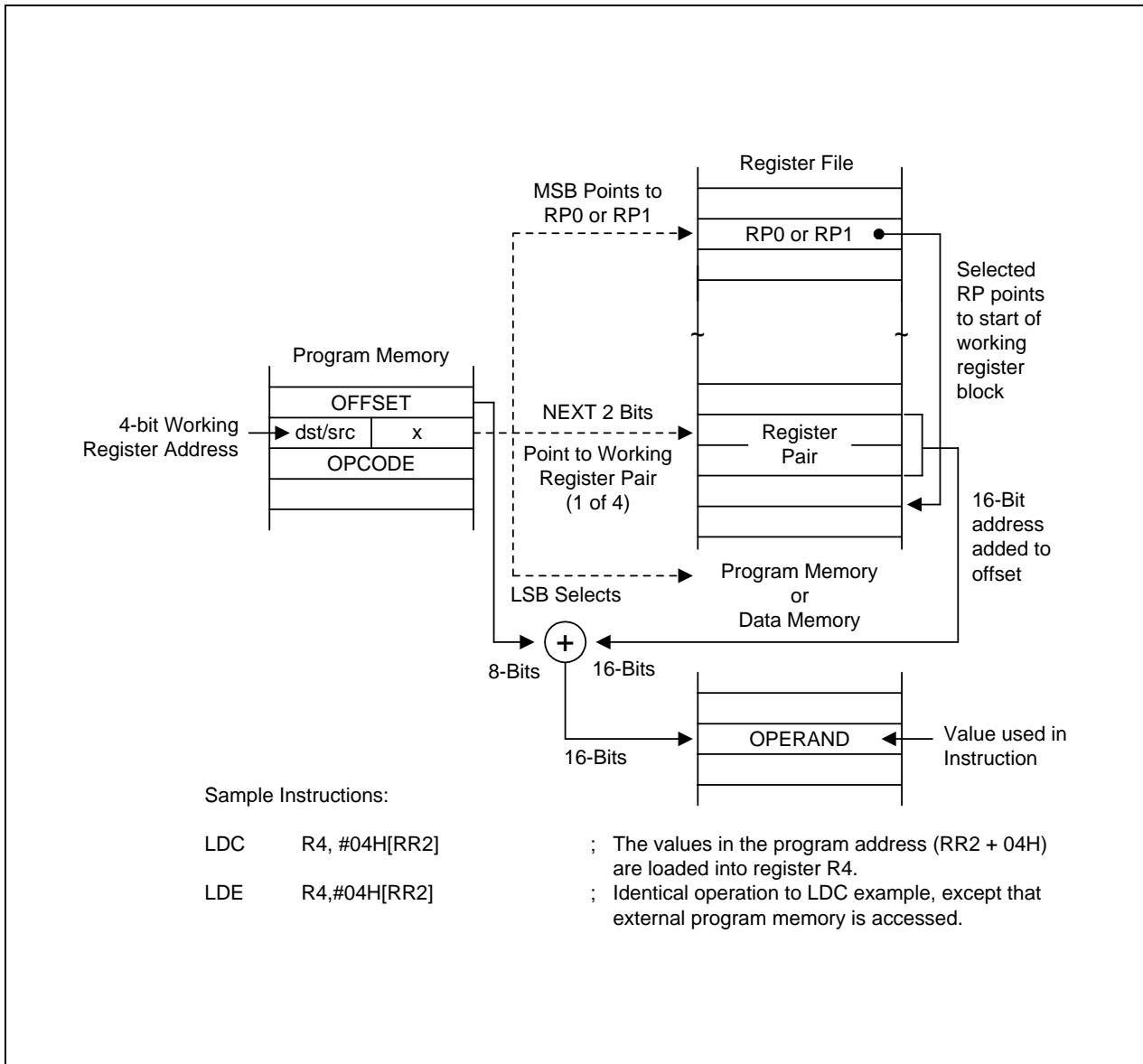


Figure 3-8. Indexed Addressing to Program or Data Memory with Short Offset

INDEXED ADDRESSING MODE (Continued)

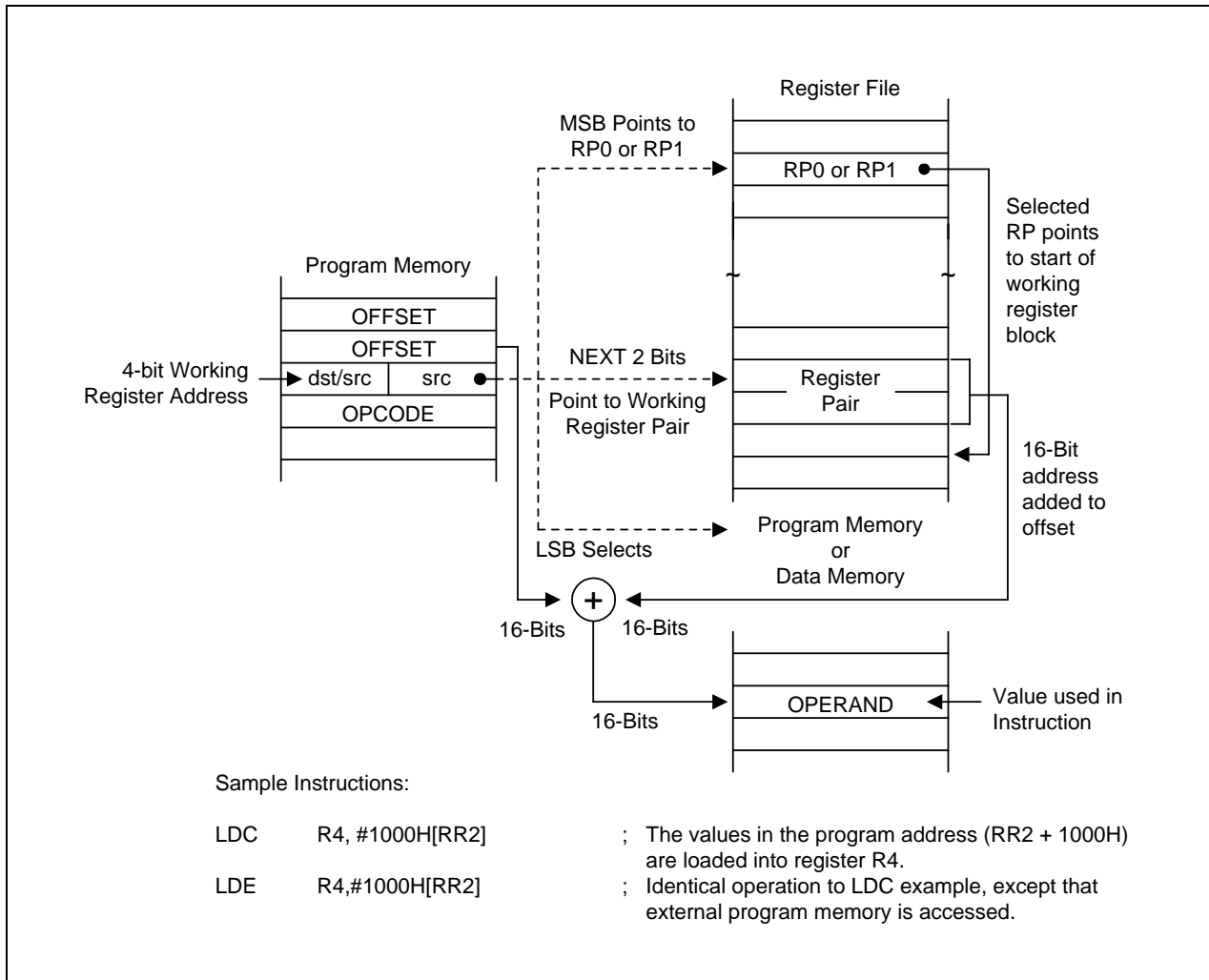


Figure 3-9. Indexed Addressing to Program or Data Memory

DIRECT ADDRESS MODE (DA)

In Direct Address (DA) mode, the instruction provides the operand's 16-bit memory address. Jump (JP) and Call (CALL) instructions use this addressing mode to specify the 16-bit destination address that is loaded into the PC whenever a JP or CALL instruction is executed.

The LDC and LDE instructions can use Direct Address mode to specify the source or destination address for Load operations to program memory (LDC) or to external data memory (LDE), if implemented.

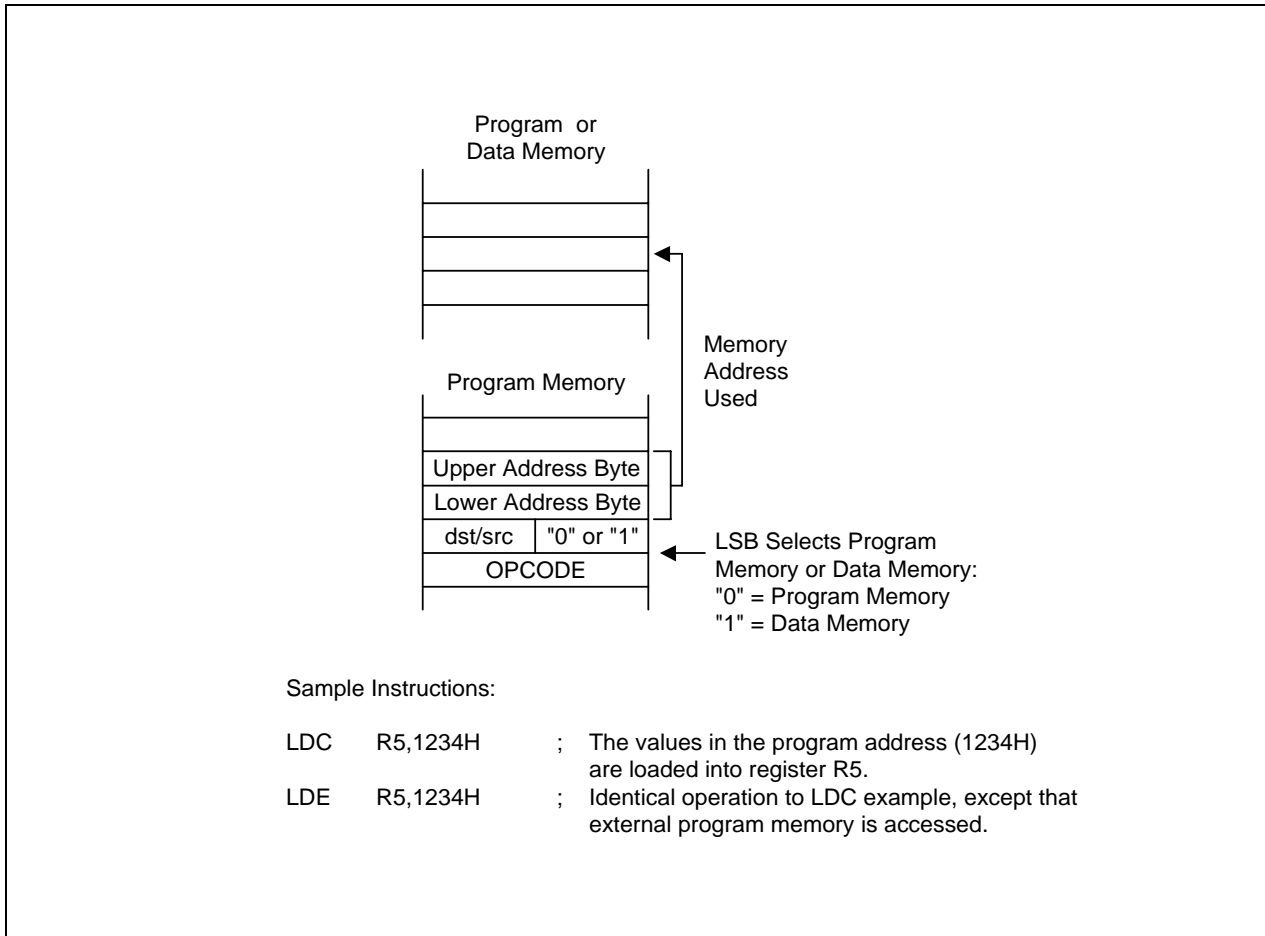
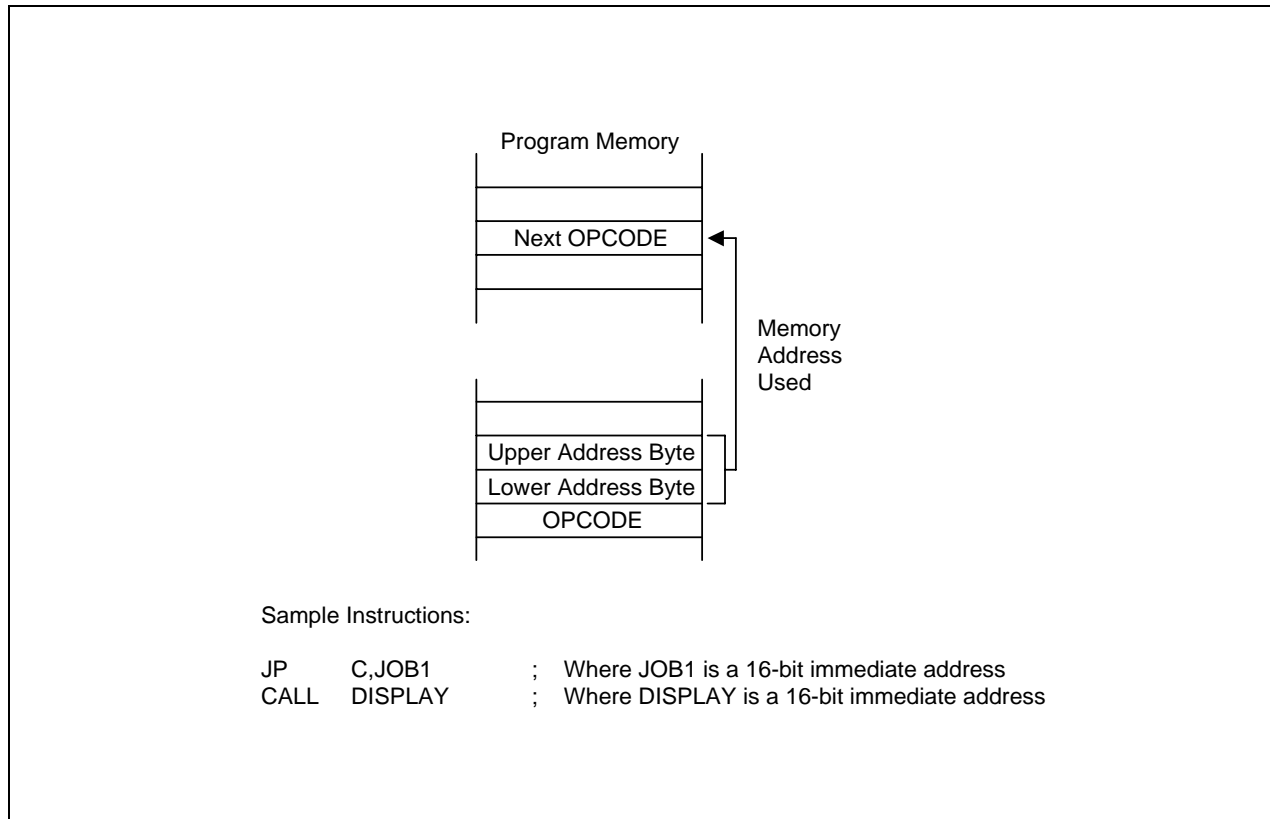


Figure 3-10. Direct Addressing for Load Instructions

DIRECT ADDRESS MODE (Continued)**Figure 3-11. Direct Addressing for Call and Jump Instructions**

INDIRECT ADDRESS MODE (IA)

In Indirect Address (IA) mode, the instruction specifies an address located in the lowest 256 bytes of the program memory. The selected pair of memory locations contains the actual address of the next instruction to be executed. Only the CALL instruction can use the Indirect Address mode.

Because the Indirect Address mode assumes that the operand is located in the lowest 256 bytes of program memory, only an 8-bit address is supplied in the instruction; the upper bytes of the destination address are assumed to be all zeros.

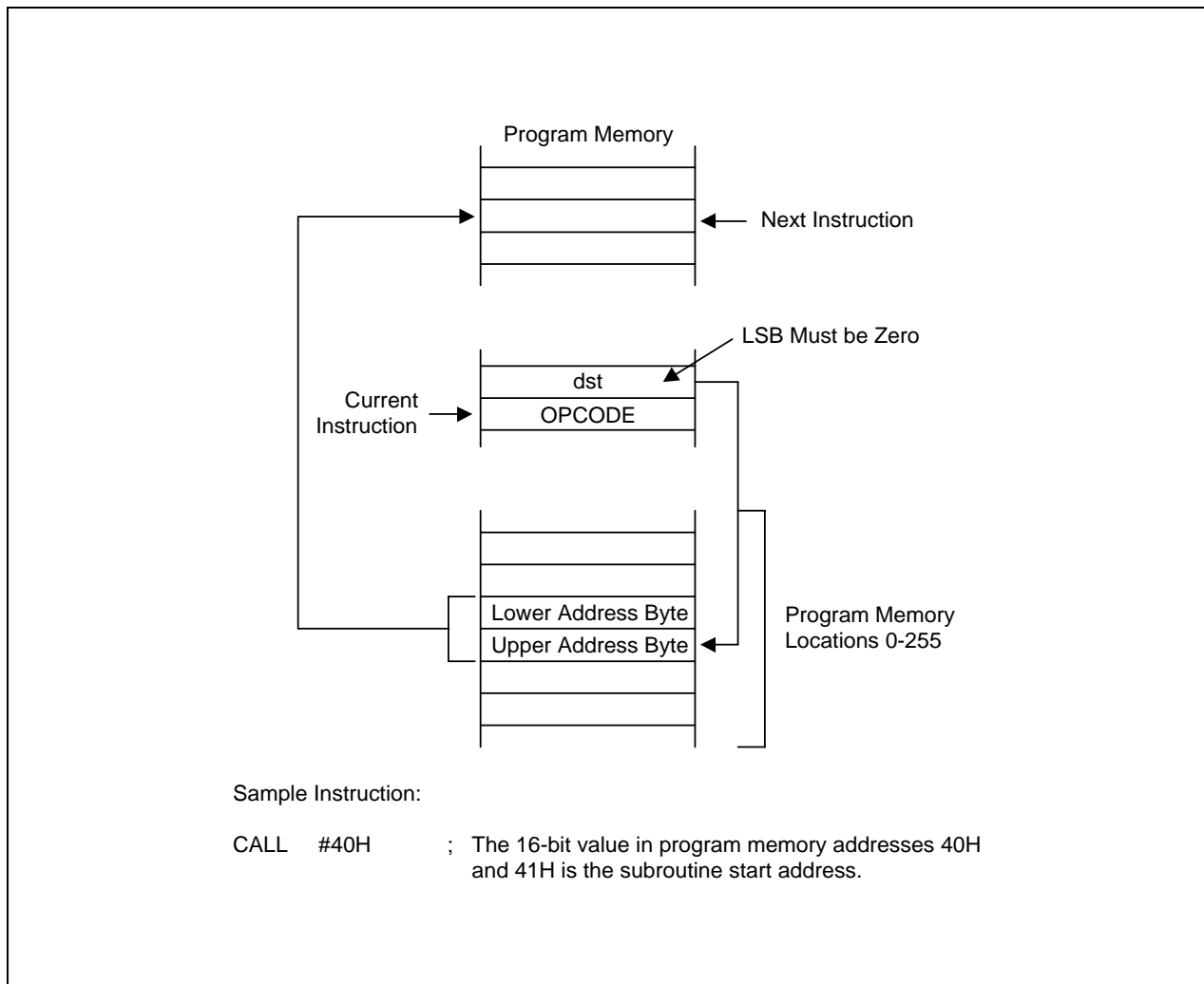


Figure 3-12. Indirect Addressing

RELATIVE ADDRESS MODE (RA)

In Relative Address (RA) mode, a two's-complement signed displacement between -128 and $+127$ is specified in the instruction. The displacement value is then added to the current PC value. The result is the address of the next instruction to be executed. Before this addition occurs, the PC contains the address of the instruction immediately following the current instruction.

Several program control instructions use the Relative Address mode to perform conditional jumps. The instructions that support RA addressing are BTJRF, BTJRT, DJNZ, CPIJE, CPIJNE, and JR.

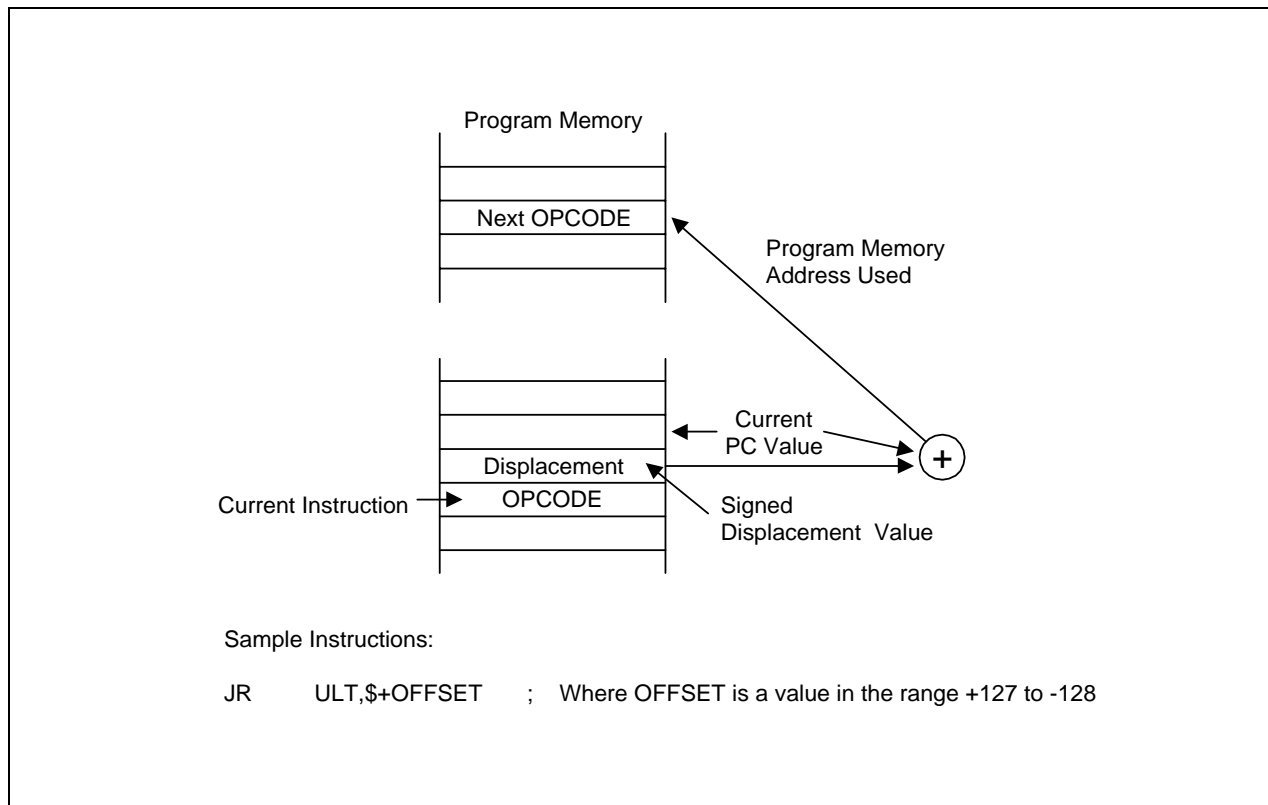


Figure 3-13. Relative Addressing

IMMEDIATE MODE (IM)

In Immediate (IM) addressing mode, the operand value used in the instruction is the value supplied in the operand field itself. The operand may be one byte or one word in length, depending on the instruction used. Immediate addressing mode is useful for loading constant values into registers.

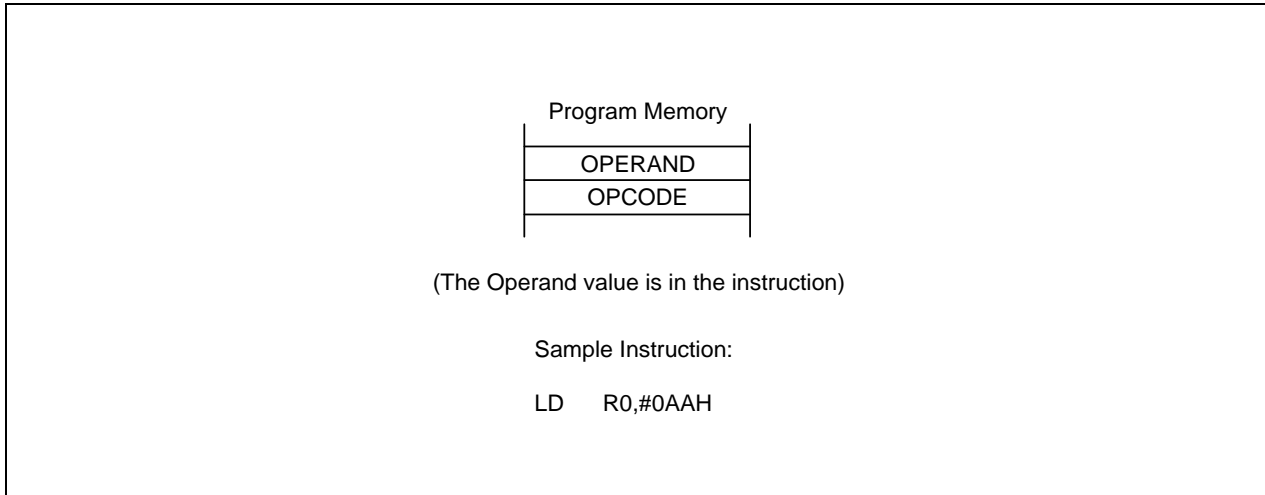


Figure 3-14. Immediate Addressing

4 CONTROL REGISTERS

OVERVIEW

Control register descriptions are arranged in alphabetical order according to register mnemonic. More detailed information about control registers is presented in the context of the specific peripheral hardware descriptions in Part II of this manual.

The locations and read/write characteristics of all mapped registers in the S3C84H5/F84H5 register file are listed in Table 4-1. The hardware reset value for each mapped register is described in Chapter 8, "RESET and Power-Down."

Table 4-1. Set 1 Registers

Register Name	Mnemonic	Decimal	Hex	R/W
Timer B control register	TBCON	208	D0H	R/W
Timer B data register (High Byte)	TBDATAH	209	D1H	R/W
Timer B data register (Low Byte)	TBDATAL	210	D2H	R/W
Basic timer control register	BTCON	211	D3H	R/W
Clock control register	CLKCON	212	D4H	R/W
System flags register	FLAGS	213	D5H	R/W
Register pointer 0	RP0	214	D6H	R/W
Register pointer 1	RP1	215	D7H	R/W
Stack pointer (High Byte)	SPH	216	D8H	R/W
Stack pointer (Low Byte)	SPL	217	D9H	R/W
Instruction pointer (High Byte)	IPH	218	DAH	R/W
Instruction pointer (Low Byte)	IPL	219	DBH	R/W
Interrupt request register	IRQ	220	DCH	R
Interrupt mask register	IMR	221	DDH	R/W
System mode register	SYM	222	DEH	R/W
Register page pointer	PP	223	DFH	R/W

Table 4-2. Set 1, Bank 0 Registers

Register Name	Mnemonic	Decimal	Hex	R/W
Port 0 data register	P0	224	E0H	R/W
Port 1 data register	P1	225	E1H	R/W
Port 2 data register	P2	226	E2H	R/W
Port 3 data register	P3	227	E3H	R/W
Location E4H is not mapped				
STOP control register	STOPCON	229	E5H	R/W
Port 0 control register	P0CON	230	E6H	R/W
Location E7H is not mapped				
Port 1 control register (High Byte)	P1CONH	232	E8H	R/W
Port 1 control register (Low Byte)	P1CONL	233	E9H	R/W
Port 1 interrupt pending register	P1INTPND	234	EAH	R/W
Port 1 interrupt control register	P1INT	235	EBH	R/W
Port 2 control register (High Byte)	P2CONH	236	ECH	R/W
Port 2 control register (Low Byte)	P2CONL	237	EDH	R/W
Location EEH is not mapped				
Port 3 control register (Low Byte)	P3CONL	239	EFH	R/W
Location F0H,F1H is not mapped				
Oscillator control register	OSCCON	242	F2H	R/W
Location F3H is not mapped				
UART pending register	UARTPND	244	F4H	R/W
UART data register	UDATA	245	F5H	R/W
UART control register	UARTCON	246	F6H	R/W
A/D converter control register	ADCON	247	F7H	R/W
A/D converter data register (High Byte)	ADDATAH	248	F8H	R
A/D converter data register (Low Byte)	ADDATAL	249	F9H	R
Port 2 pull-up enable control register	P2PUR	250	FAH	R/W
Location FBH is not mapped				
Location FCH is factory use only				
Basic timer counter register	BTCNT	253	FDH	R
Location FEH is not mapped				
Interrupt priority register	IPR	255	FFH	R/W

Table 4-3. Set 1, Bank 1 Registers

Register Name	Mnemonic	Decimal	Hex	R/W
Timer A, Timer 1 interrupt pending register	TINTPND	224	E0H	R/W
Timer A control register	TACON	225	E1H	R/W
Timer A data register	TADATA	226	E2H	R/W
Timer A counter register	TACNT	227	E3H	R
Timer 1(0) data register (High Byte)	T1DATAH0	228	E4H	R/W
Timer 1(0) data register (Low Byte)	T1DATAL0	229	E5H	R/W
Timer 1(1) data register (High Byte)	T1DATAH1	230	E6H	R/W
Timer 1(1) data register (Low Byte)	T1DATAL1	231	E7H	R/W
Timer 1(0) control register	T1CON0	232	E8H	R/W
Timer 1(1) control register	T1CON1	233	E9H	R/W
Timer 1(0) counter register (High Byte)	T1CNTH0	234	EAH	R
Timer 1(0) counter register (Low Byte)	T1CNTL0	235	EBH	R
Timer 1(1) counter register (High Byte)	T1CNTH1	236	ECH	R
Timer 1(1) counter register (Low Byte)	T1CNTL1	237	EDH	R
UART baud rate data register (High Byte)	BRDATAH	238	EEH	R/W
UART baud rate data register (Low Byte)	BRDATAL	239	EFH	R/W
SIO pre-scalar register	SIOPS	240	F0H	R/W
SIO data register	SIODATA	241	F1H	R/W
Serial I/O control register	SIOCON	242	F2H	R/W
PWM data register (High)	PWMDATAH	243	F3H	R/W
PWM data register (LOW)	PWMDATAL	244	F4H	R/W
PWM control register	PWMCON	245	F5H	R/W
Location F6, F7H is not mapped				
Watch timer control register	WTCON	248	F8H	R/W
Location F9H–FFH are not mapped				

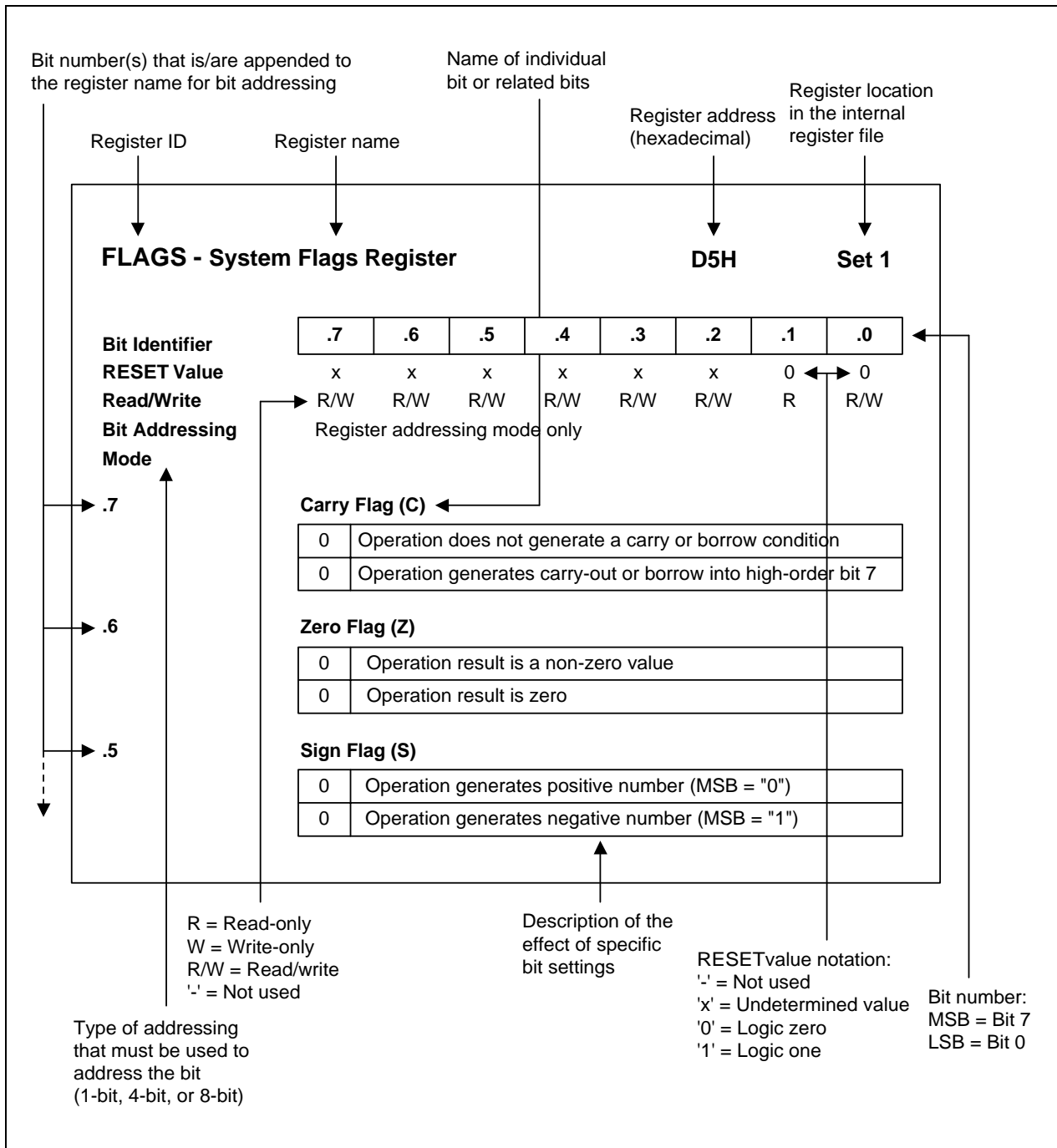


Figure 4-1. Register Description Format

ADCON — A/D Converter Control Register

F7H

Set1, Bank0

Bit Identifier	.7	.6	.5	.4	.3	.2	.1	.0
RESET Value	0	0	0	0	0	0	0	0
Read/Write	–	R/W	R/W	R/W	R	R/W	R/W	R/W
Addressing Mode	Register addressing mode only							

.7

Not used for the S3C84H5/F84H5(must keep always 0)

.6–.4

A/D Input Pin Selection Bits

0	0	0	ADC0
0	0	1	ADC1
0	1	0	ADC2
0	1	1	ADC3
1	0	0	ADC4
1	0	1	ADC5
1	1	0	ADC6
1	1	1	ADC7

.3

End-of-Conversion Bit (Read-only)

0	A/D conversion operation is in progress
1	A/D conversion operation is complete

.2–.1

Clock Source Selection Bits

0	0	fxx/16
0	1	fxx/8
1	0	fxx/4
1	1	Not used

.0

Start or Enable Bit

0	Disable operation
1	Start operation

BTCON — Basic Timer Control Register

D3H

Set 1

Bit Identifier	.7	.6	.5	.4	.3	.2	.1	.0
RESET Value	0	0	0	0	0	0	0	0
Read/Write	R/W	R/W	R/W	R/W	R/W	R/W	R/W	R/W
Addressing Mode	Register addressing mode only							

.7–.4**Watchdog Timer Function Disable Code (for System Reset)**

1	0	1	0	Disable watchdog timer function
Other Vaules				Enable watchdog timer function

.3–.2**Basic Timer Input Clock Selection Bits**

0	0	fx/4096 ⁽³⁾
0	1	fx/1024
1	0	fx/128
1	1	fx/1 (Not used)

.1**Basic Timer Counter Clear Bit ⁽¹⁾**

0	No effect
1	Clear the basic timer counter value

.0**Clock Frequency Divider Clear Bit for Basic Timer ⁽²⁾**

0	No effect
1	Clear both clock frequency dividers

NOTES:

1. When you write a "1" to BTCON.1, the basic timer counter value is cleared to "00H". Immediately following the write operation, the BTCON.1 value is automatically cleared to "0".
2. When you write a "1" to BTCON.0, the corresponding frequency divider is cleared to "00H". Immediately following the write operation, the BTCON.0 value is automatically cleared to "0".
3. The fxx is selected clock for system (main OSC. or sub OSC.).

CLKCON — System Clock Control Register

D4H

Set 1

Bit Identifier	.7	.6	.5	.4	.3	.2	.1	.0
RESET Value	0	0	0	0	0	0	0	0
Read/Write	–	–	–	R/W	R/W	–	–	–
Addressing Mode	Register addressing mode only							

.7–.5

Not used for the S3C84H5/F84H5(must keep always 0)

.4–.3

CPU Clock (System Clock) Selection Bits (note)

0	0	fx/16
0	1	fx/8
1	0	fx/2
1	1	fx/1 (non-divided)

.2–.0

Not used for the S3C84H5/F84H5(must keep always 0)

NOTE: After a reset, the slowest clock (divided by 16) is selected as the system clock. To select faster clock speeds, load the appropriate values to CLKCON.3 and CLKCON.4.

FLAGS — System Flags Register**D5H****Set 1**

Bit Identifier	.7	.6	.5	.4	.3	.2	.1	.0
RESET Value	x	x	x	x	x	x	0	0
Read/Write	R/W	R/W	R/W	R/W	R/W	R/W	R	R/W
Addressing Mode	Register addressing mode only							

.7**Carry Flag (C)**

0	Operation does not generate a carry or underflow condition
1	Operation generates a carry-out or underflow into high-order bit 7

.6**Zero Flag (Z)**

0	Operation result is a non-zero value
1	Operation result is zero

.5**Sign Flag (S)**

0	Operation generates a positive number (MSB = "0")
1	Operation generates a negative number (MSB = "1")

.4**Overflow Flag (V)**

0	Operation result is $\leq +127$ or ≥ -128
1	Operation result is $> +127$ or < -128

.3**Decimal Adjust Flag (D)**

0	Add operation completed
1	Subtraction operation completed

.2**Half-Carry Flag (H)**

0	No carry-out of bit 3 or no underflow into bit 3 by addition or subtraction
1	Addition generated carry-out of bit 3 or subtraction generated underflow into bit 3

.1**Fast Interrupt Status Flag (FIS)**

0	Interrupt return (IRET) in progress (when read)
1	Fast interrupt service routine in progress (when read)

.0**Bank Address Selection Flag (BA)**

0	Bank 0 is selected
1	Bank 1 is selected

IMR — Interrupt Mask Register

DDH

Set 1

Bit Identifier	.7	.6	.5	.4	.3	.2	.1	.0
RESET Value	x	x	x	x	x	x	x	x
Read/Write	R/W	R/W	R/W	R/W	R/W	R/W	R/W	R/W
Addressing Mode	Register addressing mode only							

.7**Interrupt Level 7 (IRQ7) Enable Bit**

0	Disable (mask)
1	Enable (un-mask)

.6**Interrupt Level 6 (IRQ6) Enable Bit**

0	Disable (mask)
1	Enable (un-mask)

.5**Interrupt Level 5 (IRQ5) Enable Bit**

0	Disable (mask)
1	Enable (un-mask)

.4**Interrupt Level 4 (IRQ4) Enable Bit**

0	Disable (mask)
1	Enable (un-mask)

.3**Interrupt Level 3 (IRQ3) Enable Bit**

0	Disable (mask)
1	Enable (un-mask)

.2**Interrupt Level 2 (IRQ2) Enable Bit**

0	Disable (mask)
1	Enable (un-mask)

.1**Interrupt Level 1 (IRQ1) Enable Bit**

0	Disable (mask)
1	Enable (un-mask)

.0**Interrupt Level 0 (IRQ0) Enable Bit**

0	Disable (mask)
1	Enable (un-mask)

NOTE: When an interrupt level is masked, any interrupt requests that may be issued are not recognized by the CPU.

IPH — Instruction Pointer (High Byte)

DAH

Set 1

Bit Identifier	.7	.6	.5	.4	.3	.2	.1	.0
RESET VALUE	x	x	x	x	x	x	x	x
Read/Write	R/W	R/W	R/W	R/W	R/W	R/W	R/W	R/W
Addressing Mode	Register addressing mode only							

.7–.0

Instruction Pointer Address (High Byte)

The high-byte instruction pointer value is the upper eight bits of the 16-bit instruction pointer address (IP15–IP8). The lower byte of the IP address is located in the IPL register (DBH).

IPL — Instruction Pointer (Low Byte)

DBH

Set 1

Bit Identifier	.7	.6	.5	.4	.3	.2	.1	.0
RESET VALUE	x	x	x	x	x	x	x	x
Read/Write	R/W	R/W	R/W	R/W	R/W	R/W	R/W	R/W
Addressing Mode	Register addressing mode only							

.7–.0

Instruction Pointer Address (Low Byte)

The low-byte instruction pointer value is the lower eight bits of the 16-bit instruction pointer address (IP7–IP0). The upper byte of the IP address is located in the IPH register (DAH).

IPR — Interrupt Priority Register

FFH

Set1, Bank0

Bit Identifier	.7	.6	.5	.4	.3	.2	.1	.0
RESET Value	x	x	x	x	x	x	x	x
Read/Write	R/W	R/W	R/W	R/W	R/W	R/W	R/W	R/W
Addressing Mode	Register addressing mode only							

.7, .4, and .1**Priority Control Bits for Interrupt Groups A, B, and C**

0	0	0	Group priority undefined
0	0	1	B > C > A
0	1	0	A > B > C
0	1	1	B > A > C
1	0	0	C > A > B
1	0	1	C > B > A
1	1	0	A > C > B
1	1	1	Group priority undefined

.6**Interrupt Subgroup C Priority Control Bit**

0	IRQ6 > IRQ7
1	IRQ7 > IRQ6

.5**Interrupt Group C Priority Control Bit**

0	IRQ5 > (IRQ6, IRQ7)
1	(IRQ6, IRQ7) > IRQ5

.3**Interrupt Subgroup B Priority Control Bit**

0	IRQ3 > IRQ4
1	IRQ4 > IRQ3

.2**Interrupt Group B Priority Control Bit**

0	IRQ2 > (IRQ3, IRQ4)
1	(IRQ3, IRQ4) > IRQ2

.0**Interrupt Group A Priority Control Bit**

0	IRQ0 > IRQ1
1	IRQ1 > IRQ0

IRQ — Interrupt Request Register**DCH****Set 1**

Bit Identifier	.7	.6	.5	.4	.3	.2	.1	.0
RESET Value	0	0	0	0	0	0	0	0
Read/Write	R	R	R	R	R	R	R	R
Addressing Mode	Register addressing mode only							

.7 Interrupt Level 7 (IRQ7) Request Pending Bit

0	Not pending
1	Pending

.6 Interrupt Level 6 (IRQ6) Request Pending Bit

0	Not pending
1	Pending

.5 Interrupt Level 5 (IRQ5) Request Pending Bit

0	Not pending
1	Pending

.4 Interrupt Level 4 (IRQ4) Request Pending Bit

0	Not pending
1	Pending

.3 Interrupt Level 3 (IRQ3) Request Pending Bit

0	Not pending
1	Pending

.2 Interrupt Level 2 (IRQ2) Request Pending Bit

0	Not pending
1	Pending

.1 Interrupt Level 1 (IRQ1) Request Pending Bit

0	Not pending
1	Pending

.0 Interrupt Level 0 (IRQ0) Request Pending Bit

0	Not pending
1	Pending

OSCCON — Oscillator Control Register

F2H

Set1, Bank0

Bit Identifier	.7	.6	.5	.4	.3	.2	.1	.0
RESET Value	0	0	0	0	0	0	0	0
Read/Write	–	–	–	R/W	R/W	R/W	–	R/W
Addressing Mode	Register addressing mode only							

.7–.4

Not used for the S3C84I8/F84I9 (must keep always 0)

.3**Main System Oscillator Control Bit**

0	Main System Oscillator RUN
1	Main System Oscillator STOP

.2**Sub System Oscillator Control Bit**

0	Sub system oscillator RUN
1	Sub system oscillator STOP

.1

Not used for the S3C84H5/F84H5 (must keep always 0)

.0**System Clock Selection Bit**

0	Main oscillator select
1	Subsystem oscillator select

P0CON — Port 0 Control Register (High Byte)

E6H

Set1, Bank0

Bit Identifier	.7	.6	.5	.4	.3	.2	.1	.0
RESET Value	0	0	0	0	0	0	0	0
Read/Write	R/W	R/W	R/W	R/W	R/W	R/W	R/W	R/W
Addressing Mode	Register addressing mode only							

.7–.6**P0.3/AD3 Configuration Bits**

0	0	Input mode
0	1	Input mode with pull-up
1	0	Push-pull output mode
1	1	Alternative function mode; AD3 input

.5–.4**P0.2/AD2 Configuration Bits**

0	0	Input mode
0	1	Input mode with pull-up
1	0	Push-pull output mode
1	1	Alternative function mode; AD2 input

.3–.2**P0.1/ AD1 Configuration Bits**

0	0	Input mode
0	1	Input mode with pull-up
1	0	Push-pull output mode
1	1	Alternative function mode; AD1 input

.1–.0**P0.0/ AD0 Configuration Bits**

0	0	Input mode
0	1	Input mode with pull-up
1	0	Push-pull output mode
1	1	Alternative function mode; AD0 input

NOTE: In debug mode, you have to include three extra commands in initial routine to operate Ports correctly. If you omit these commands, Port do not operate correctly. (Refer to page 9-14)
After you have finished your program and before assembling, you have to remove these three commands.

```
.ORG 100H
SB1          ; Extra command only for debugging
LD          0F7H,#5FH          ; Extra command only for debugging
SB0          ; Extra command only for debugging
```

P1CONH — Port 1 Control Register (High Byte)**E8H****Set1, Bank0**

Bit Identifier	.7	.6	.5	.4	.3	.2	.1	.0
RESET Value	0	0	0	0	0	0	0	0
Read/Write	–	–	–	–	R/W	R/W	R/W	R/W
Addressing Mode	Register addressing mode only							

.7–.4

Not used for the S3C84H5/F84H5 (must keep always 0)

.3–.2**P1.5/T1CAP1/AD6 Configuration Bits**

0	0	Input mode (T1CAP1 input)
0	1	Input mode with pull-up (T1CAP1 input)
1	0	Push-pull output mode
1	1	Alternative function mode: AD6

.1–.0**P1.4/T1CK1/AD5 Configuration Bits**

0	0	Input mode; (T1CK1 input)
0	1	Input mode with pull-up; (T1CK1 input)
1	0	Push-pull output mode
1	1	Alternative function mode: AD5

NOTE: In debug mode, you have to include three extra commands in initial routine to operate Ports correctly. If you omit these commands, Port do not operate correctly. (Refer to page 9-14)
After you have finished your program and before assembling, you have to remove these three commands.

```
.ORG 100H
SB1          ; Extra command only for debugging
LD  0F7H,#5FH ; Extra command only for debugging
SB0          ; Extra command only for debugging
```

P1CONL — Port 1 Control Register (Low Byte)**E9H****Set1, Bank0**

Bit Identifier	.7	.6	.5	.4	.3	.2	.1	.0
RESET Value	0	0	0	0	0	0	0	0
Read/Write	R/W	R/W	R/W	R/W	R/W	R/W	R/W	R/W
Addressing Mode	Register addressing mode only							

.7–.6**P1.3/T1OUT0/INT3 Configuration Bits**

0	0	Input mode ; Interrupt input (INT3)
0	1	Input mode with pull-up ; Interrupt input (INT3)
1	0	Push-pull output mode
1	1	Alternative function mode: T1OUT0 mode

.5–.4**P1.2/TACAP/INT2 Configuration Bits**

0	0	Input mode ; Interrupt input (INT2); TACAP
0	1	Input mode with pull-up ; Interrupt input (INT2) ; TACAP
1	0	Push-pull output mode
1	1	Alternative function mode: Not used

.3–.2**P1.1/TACK/BUZ/INT1 Configuration Bits**

0	0	Input mode ; Interrupt input (INT1); TACK
0	1	Input mode with pull-up ; Interrupt input (INT1); TACK
1	0	Push-pull output mode
1	1	Alternative function mode: BUZ out mode

.1–.0**P1.0/TAOUT/INT0 Configuration Bits**

0	0	Input mode ; Interrupt input (INT0)
0	1	Input mode with pull-up ; Interrupt input (INT0)
1	0	Push-pull output mode
1	1	Alternative function mode: TAOUT mode

NOTE: In debug mode, you have to include three extra commands in initial routine to operate Ports correctly. If you omit these commands, Port do not operate correctly. (Refer to page 9-14)
After you have finished your program and before assembling, you have to remove these three commands.

```
.ORG 100H
SB1           ; Extra command only for debugging
LD    0F7H,#5FH ; Extra command only for debugging
SB0           ; Extra command only for debugging
```

P1INTPND — Port 1 Interrupt Pending Register

EAH

Set1, Bank0

Bit Identifier	.7	.6	.5	.4	.3	.2	.1	.0
RESET Value	–	–	–	–	0	0	0	0
Read/Write	–	–	–	–	R/W	R/W	R/W	R/W
Addressing Mode	Register addressing mode only							

.7–.4

Not used for S3C84H5/F84H5

.3

P1.3/INT3 Interrupt Pending Bit

0	Interrupt request is not pending, pending bit clear when write 0
1	Interrupt request is pending

.2

P1.2/INT2 Interrupt Pending Bit

0	Interrupt request is not pending, pending bit clear when write 0
1	Interrupt request is pending

.1

P1.1/INT1 Interrupt Pending Bit

0	Interrupt request is not pending, pending bit clear when write 0
1	Interrupt request is pending

.0

P1.0/INT0 Interrupt Pending Bit

0	Interrupt request is not pending, pending bit clear when write 0
1	Interrupt request is pending

P1INT — Port 1 Interrupt Enable

EBH

Set1, Bank0

Bit Identifier	.7	.6	.5	.4	.3	.2	.1	.0
RESET Value	0	0	0	0	0	0	0	0
Read/Write	R/W	R/W	R/W	R/W	R/W	R/W	R/W	R/W
Addressing Mode	Register addressing mode only							

.7–.6**P1.3's Interrupt Enable/Disable Selection Bit**

0	x	Interrupt Disable
1	0	Interrupt Enable; Falling edge
1	1	Interrupt Enable; Rising edge

.5–.4**P1.2's Interrupt Enable/Disable Selection Bit**

0	x	Interrupt Disable
1	0	Interrupt Enable; Falling edge
1	1	Interrupt Enable; Rising edge

.3–.3**P1.1's Interrupt Enable/Disable Selection Bit**

0	x	Interrupt Disable
1	0	Interrupt Enable; Falling edge
1	1	Interrupt Enable; Rising edge

.1–.0**P1.0's Interrupt Enable/Disable Selection Bit**

0	x	Interrupt Disable
1	0	Interrupt Enable; Falling edge
1	1	Interrupt Enable; Rising edge

P2CONH — Port 2 Control Register (High Byte)

ECH

Set1, Bank0

Bit Identifier	.7	.6	.5	.4	.3	.2	.1	.0
RESET Value	0	0	0	0	0	0	0	0
Read/Write	R/W	R/W	R/W	R/W	R/W	R/W	R/W	R/W
Addressing Mode	Register addressing mode only							

.7–.6**P2.7/TxD Configuration Bits**

0	0	Input mode
0	1	Alternative function mode: Not used
1	0	Push-pull output mode
1	1	Alternative function mode: TxD output

.5–.4**P2.6/RxD Configuration Bits**

0	0	Input mode ; RxD input
0	1	Alternative function mode: Not used
1	0	Push-pull output mode
1	1	Alternative function mode: RxD output

.3–.2**P2.5/SCK Configuration Bits**

0	0	Input mode ; SCK input
0	1	Alternative function mode: Not used
1	0	Push-pull output mode
1	1	Alternative function mode: SCK output

.1–.0**P2.4/SO Configuration Bits**

0	0	Input mode
0	1	Alternative function mode: Not used
1	0	Push-pull output mode
1	1	Alternative function mode: SO output

NOTE: In debug mode, you have to include three extra commands in initial routine to operate Ports correctly. If you omit these commands, Port do not operate correctly. (Refer to page 9-14)
After you have finished your program and before assembling, you have to remove these three commands.

```
.ORG 100H
SB1           ; Extra command only for debugging
LD   0F7H,#5FH ; Extra command only for debugging
SB0           ; Extra command only for debugging
```

P2CONL — Port 2 Control Register (Low Byte)

EDH

Set1, Bank0

Bit Identifier	.7	.6	.5	.4	.3	.2	.1	.0
RESET Value	0	0	0	0	0	0	0	0
Read/Write	R/W	R/W	R/W	R/W	R/W	R/W	R/W	R/W
Addressing Mode	Register addressing mode only							

.7–.6**P2.3/AD7/SI Configuration Bits**

0	0	Input mode ;SI input
0	1	Alternative function mode: Not used
1	0	Push-pull output mode
1	1	Alternative function mode: AD7

.5–.4**P2.2/AD4/T1OUT1 Configuration Bits**

0	0	Input mode ;
0	1	Alternative function mode: T1OUT1
1	0	Push-pull output mode
1	1	Alternative function mode: AD4

.3–.2**P2.1/PWM/T1CAP0 Configuration Bits**

0	0	Input mode ;T1CAP0 input
0	1	Alternative function mode: Not used
1	0	Push-pull output mode
1	1	Alternative function mode: PWM mode

.1–.0**P2.0/TBPWM/T1CK0 Configuration Bits**

0	0	Input mode ; T1CK0 input
0	1	Alternative function mode: T1CK0 input
1	0	Push-pull output mode
1	1	Alternative function mode: TBPWM mode

NOTE: In debug mode, you have to include three extra commands in initial routine to operate Ports correctly. If you omit these commands, Port do not operate correctly. (Refer to page 9-14)
After you have finished your program and before assembling, you have to remove these three commands.

```
.ORG 100H
SB1           ; Extra command only for debugging
LD    0F7H,#5FH ; Extra command only for debugging
SB0           ; Extra command only for debugging
```


P2PUR — Port 2 Pull-up Resistor Control Register

FAH

Set1, Bank0

Bit Identifier	.7	.6	.5	.4	.3	.2	.1	.0
RESET Value	1	1	1	1	1	1	1	1
Read/Write	R/W	R/W	R/W	R/W	R/W	R/W	R/W	R/W

.7**P2.7 Pull-up Resistor Enable/Disable**

0	Pull-up resistor disable
1	Pull-up resistor enable

.6**P2.6 Pull-up Resistor Enable/Disable**

0	Pull-up resistor disable
1	Pull-up resistor enable

.5**P2.5 Pull-up Resistor Enable/Disable**

0	Pull-up resistor disable
1	Pull-up resistor enable

.4**P1.4 Pull-up Resistor Enable/Disable**

0	Pull-up resistor disable
1	Pull-up resistor enable

.3**P2.3 Pull-up Resistor Enable/Disable**

0	Pull-up resistor disable
1	Pull-up resistor enable

.2**P2.2 Pull-up Resistor Enable/Disable**

0	Pull-up resistor disable
1	Pull-up resistor enable

.1**P2.1 Pull-up Resistor Enable/Disable**

0	Pull-up resistor disable
1	Pull-up resistor enable

.0**P2.0 Pull-up Resistor Enable/Disable**

0	Pull-up resistor disable
1	Pull-up resistor enable



P3CONL — Port 3 Control Register (Low Byte)

EFH

Set1, Bank0

Bit Identifier	.7	.6	.5	.4	.3	.2	.1	.0
RESET Value	0	0	0	0	0	0	0	0
Read/Write	R/W	R/W	R/W	R/W	R/W	R/W	R/W	R/W
Addressing Mode	Register addressing mode only							

.7–.6**P3.3 Configuration Bits**

0	0	Input mode
0	1	Input mode with pull-up
1	0	Push-pull output mode
1	1	N-channel open-drain output

.5–.4**P3.2 Configuration Bits**

0	0	Input mode
0	1	Input mode with pull-up
1	0	Push-pull output mode
1	1	N-channel open-drain output

.3–.3**P3.1 Configuration Bits**

0	0	Input mode
0	1	Input mode with pull-up
1	0	Push-pull output mode
1	1	N-channel open-drain output

.1–.0**P3.0 Configuration Bits**

0	0	Input mode
0	1	Input mode with pull-up
1	0	Push-pull output mode
1	1	N-channel open-drain output

NOTE: In debug mode, you have to include three extra commands in initial routine to operate Ports correctly. If you omit these commands, Port do not operate correctly. (Refer to page 9-14)
After you have finished your program and before assembling, you have to remove these three commands.

```
.ORG 100H
SB1          ; Extra command only for debugging
LD  0F7H,#5FH ; Extra command only for debugging
SB0          ; Extra command only for debugging
```

PP — Register Page Pointer**DFH****Set1**

Bit Identifier	.7	.6	.5	.4	.3	.2	.1	.0
RESET Value	0	0	0	0	0	0	0	0
Read/Write	R/W	R/W	R/W	R/W	R/W	R/W	R/W	R/W
Addressing Mode	Register addressing mode only							

.7-4**Destination Register Page Selection Bits**

0	0	0	0	Destination: page 0
Other values				Don't care

.3-0**Source Register Page Selection Bits**

0	0	0	0	Source: page 0
Other values				Don't care

NOTE: In the S3C84H5/F84H5 microcontroller, the internal register file is configured as one page (Pages 0). The pages 0 are used for the general-purpose register file and data register.

PWMCON — PWM Control Register

F5H

Set1, Bank1

Bit Identifier	.7	.6	.5	.4	.3	.2	.1	.0
RESET Value	0	0	–	0	0	0	0	0
Read/Write	R/W	R/W	–	R/W	R/W	R/W	R/W	R/W

.7–.6

PWM Input Clock Selection Bits

0	0	$f_{OSC}/64$
0	1	$f_{OSC}/8$
1	0	$f_{OSC}/2$
1	1	$f_{OSC}/1$

.5

Not used for S3C84H5/F84H5

.4

PWMDATA Reload Interval Selection Bit

0	Reload from 10-bit up counter overflow
1	Reload from 8-bit up counter overflow

.3

PWM Counter Clear Bit

0	No effect
1	Clear the PWM counter (when write)

.2

PWM Counter Enable Bit

0	Stop counter
1	Start (Resume countering)

.1

PWM Overflow Interrupt Enable Bit (8-Bit Overflow)

0	Disable interrupt
1	Enable interrupt

.0

PWM Overflow Interrupt Pending Bit

0	No interrupt pending (when read)
0	Clear pending bit (when write)
1	Interrupt is pending (when read)

NOTE: PWMCON.3 is not auto-cleared. You must pay attention when clear pending bit. (refer to page 13-7).

RP0 — Register Pointer 0**D6H****Set1**

Bit Identifier	.7	.6	.5	.4	.3	.2	.1	.0
RESET Value	1	1	0	0	0	–	–	–
Read/Write	R/W	R/W	R/W	R/W	R/W	–	–	–
Addressing Mode	Register addressing only							

.7-3**Register Pointer 0 Address Value**

Register pointer 0 can independently point to one of the 256-byte working register areas in the register file. Using the register pointers RP0 and RP1, you can select two 8-byte register slices at one time as active working register space. After a reset, RP0 points to address C0H in register set 1, selecting the 8-byte working register slice C0H–C7H.

.2-0

Not used for the S3C84H5/F84H5

RP1 — Register Pointer 1**D7H****Set 1**

Bit Identifier	.7	.6	.5	.4	.3	.2	.1	.0
RESET Value	1	1	0	0	1	–	–	–
Read/Write	R/W	R/W	R/W	R/W	R/W	–	–	–
Addressing Mode	Register addressing only							

.7-3**Register Pointer 1 Address Value**

Register pointer 1 can independently point to one of the 256-byte working register areas in the register file. Using the register pointers RP0 and RP1, you can select two 8-byte register slices at one time as active working register space. After a reset, RP1 points to address C8H in register set 1, selecting the 8-byte working register slice C8H–CFH.

.2-0

Not used for the S3C84H5/F84H5

SIOCON — Serial I/O Module Control Registers

F2H

Set1, Bank1

Bit Identifier	.7	.6	.5	.4	.3	.2	.1	.0
RESET Value	0	0	0	0	0	0	0	0
Read/Write	R/W	R/W	R/W	R/W	R/W	R/W	R/W	R/W

.7**SIO Shift Clock Selection Bit**

0	Interval clock (P.S Clock)
1	External clock (SCK)

.6**Data Direction Control Bit**

0	MSB-first mode
1	LSB-first mode

.5**SIO Mode Selection Bit**

0	Receive-only mode
1	Transmit/Receive mode

.4**Shift Clock Edge Selection Bit**

0	Tx at falling edges, Rx at rising edges.
1	Tx at rising edges, Rx at falling edges.

.3**SIO Counter Clear and Shift Start Bit**

0	No action
1	Clear 3-bit counter and start shifting

.2**SIO Shift Operation Enable Bit**

0	Disable shift and clock counter
1	Enable shift and clock counter

.1**SIO Interrupt Enable Bit**

0	Disable SIO interrupt
1	Enable SIO interrupt

.0**SIO Interrupt Pending Bit**

0	No interrupt pending
1	Interrupt pending (<i>Clear pending bit when write</i>)

SIOPS — SIO Prescaler Register

F0H

Set1, Bank1

Bit Identifier	.7	.6	.5	.4	.3	.2	.1	.0
RESET Value	0	0	0	0	0	0	0	0
Read/Write	R/W	R/W	R/W	R/W	R/W	R/W	R/W	R/W
Addressing Mode	Register addressing mode only							

.7–.0

Baud rate = Input clock (f _{xx})/[(SIOPS + 1) × 4] or SCK input clock

SPH — Stack Pointer (High Byte)

D8H

Set 1

Bit Identifier	.7	.6	.5	.4	.3	.2	.1	.0
RESET Value	x	x	x	x	x	x	x	x
Read/Write	R/W	R/W	R/W	R/W	R/W	R/W	R/W	R/W
Addressing Mode	Register addressing mode only							

.7–.0

Stack Pointer Address (High Byte)

The high-byte stack pointer value is the upper eight bits of the 16-bit stack pointer address (SP15–SP8). The lower byte of the stack pointer value is located in register SPL (D9H). The SP value is undefined following a reset.
--

SPL — Stack Pointer (Low Byte)

D9H

Set 1

Bit Identifier	.7	.6	.5	.4	.3	.2	.1	.0
RESET Value	x	x	x	x	x	x	x	x
Read/Write	R/W	R/W	R/W	R/W	R/W	R/W	R/W	R/W
Addressing Mode	Register addressing mode only							

.7–.0

Stack Pointer Address (Low Byte)

The low-byte stack pointer value is the lower eight bits of the 16-bit stack pointer address (SP7–SP0). The upper byte of the stack pointer value is located in register SPH (D8H). The SP value is undefined following a reset.
--

STOPCON — Stop Control Register

E5H

Set1, Bank0

Bit Identifier	.7	.6	.5	.4	.3	.2	.1	.0
RESET Value	0	0	0	0	0	0	0	0
Read/Write	R/W	R/W	R/W	R/W	R/W	R/W	R/W	R/W
Addressing Mode	Register addressing mode only							

.7–.0**STOP Control Bits**

1 0 1 0 0 1 0 1	Enable stop instruction
Other values	Disable stop instruction

NOTE: Before execute the STOP instruction, You must set this STPCON register as “10100101b”. Otherwise the STOP instruction will not be executed.

SYM — System Mode Register

DEH

Set 1

Bit Identifier	.7	.6	.5	.4	.3	.2	.1	.0
RESET Value	0	0	0	x	x	x	0	0
Read/Write	–	–	–	R/W	R/W	R/W	R/W	R/W
Addressing Mode	Register addressing mode only							

.7–.5

Not used, But you must keep always 0

.4–.2

Fast Interrupt Level Selection Bits

0	0	0	IRQ0
0	0	1	IRQ1
0	1	0	IRG2
0	1	1	IRQ3
1	0	0	IRQ4
1	0	1	IRQ5
1	1	0	IRQ6
1	1	1	IRQ7

.1

Fast Interrupt Enable Bit

0	Disable fast interrupt processing
1	Enable fast interrupt processing

.0

Global Interrupt Enable Bit ^(note)

0	Disable global interrupt processing
1	Enable global interrupt processing

NOTE: Following a reset, you enable global interrupt processing by executing an EI instruction (not by writing a "1" to SYM.0).

T1CON0 — Timer 1(0) Control Register

E8H

Set1, Bank1

Bit Identifier	.7	.6	.5	.4	.3	.2	.1	.0
RESET Value	0	0	0	0	0	0	0	0
Read/Write	R/W	R/W	R/W	R/W	R/W	R/W	R/W	R/W
Addressing Mode	Register addressing mode only							

.7–.5**Timer 1(0) Input Clock Selection Bits**

0	0	0	fx/1024
0	0	1	fx/256
0	1	0	fx/64
0	1	1	fx/8
1	0	0	fx
1	0	1	External clock falling edge
1	1	0	External clock rising edge
1	1	1	Counter stop

.4–.3**Timer 1(0) Operating Mode Selection Bits**

0	0	Interval mode
0	1	Capture mode (Capture on rising edge, OVF can occur)
1	0	Capture mode (Capture on falling edge, OVF can occur)
1	1	PWM mode

.2**Timer 1(0) Counter Enable Bit**

0	No effect
1	Clear the timer 1(0) counter (Auto-clear bit)

.1**Timer 1(0) Match/Capture Interrupt Enable Bit**

0	Disable interrupt
1	Enable interrupt

.0**Timer 1(0) Overflow Interrupt Enable**

0	Disable overflow interrupt
1	Enable overflow interrupt

T1CON1 — Timer 1(1) Control Register

E9H

Set1, Bank1

Bit Identifier	.7	.6	.5	.4	.3	.2	.1	.0
RESET VALUE	0	0	0	0	0	0	0	0
Read/Write	R/W	R/W	R/W	R/W	R/W	R/W	R/W	R/W
Addressing Mode	Register addressing mode only							

.7-5**Timer 1(1) Input Clock Selection Bits**

0	0	0	fx/1024
0	0	1	fx/256
0	1	0	fx/64
0	1	1	fx/8
1	0	0	fx
1	0	1	External clock falling edge
1	1	0	External clock rising edge
1	1	1	Counter stop

.4-3**Timer 1(1) Operating Mode Selection Bits**

0	0	Interval mode
0	1	Capture mode (Capture on rising edge, OVF can occur)
1	0	Capture mode (Capture on falling edge, OVF can occur)
1	1	PWM mode

.2**Timer 1(1) Counter Enable Bit**

0	No effect
1	Clear the timer 1(1) counter (Auto-clear bit)

.1**Timer 1(1) Match/Capture Interrupt Enable Bit**

0	Disable interrupt
1	Enable interrupt

.0**Timer 1(1) Overflow Interrupt Enable**

0	Disable overflow interrupt
1	Enable overflow interrupt

TACON — Timer A Control Register

E1H

Set1, Bank1

Bit Identifier	.7	.6	.5	.4	.3	.2	.1	.0
RESET VALUE	0	0	0	0	0	0	0	0
Read/Write	R/W	R/W	R/W	R/W	R/W	R/W	R/W	R/W
Addressing Mode	Register addressing mode only							

.7-6**Timer A Input Clock Selection Bits**

0	0	fx/1024
0	1	fx/256
1	0	fx/64
1	1	External clock (TACK)

.5-4**Timer A Operating Mode Selection Bits**

0	0	Interval mode (TAOUT mode)
0	1	Capture mode (capture on rising edge, counter running, OVF can occur)
1	0	Capture mode (capture on falling edge, counter running, OVF can occur)
1	1	PWM mode (OVF interrupt can occur)

.3**Timer A Counter Clear Bit**

0	No effect
1	Clear the timer A counter (Auto-clear bit)

.2**Timer A Overflow Interrupt Enable Bit**

0	Disable overflow interrupt
1	Enable overflow interrupt

.1**Timer A Match/Capture Interrupt Enable Bit**

0	Disable interrupt
1	Enable interrupt

.0**Timer A Start/Stop Bit**

0	Stop Timer A
1	Start Timer A

TBCON — Timer B Control Register

D0H

Set 1

Bit Identifier	.7	.6	.5	.4	.3	.2	.1	.0
RESET VALUE	0	0	0	0	0	0	0	0
Read/Write	R/W	R/W	R/W	R/W	R/W	R/W	R/W	R/W
Addressing Mode	Register addressing mode only							

.7–.6**Timer B Input Clock Selection Bits**

0	0	fx/4
0	1	fx/8
1	0	fx/64
1	1	fx/256

.5–.4**Timer B Interrupt Time Selection Bits**

0	0	Elapsed time for low data value
0	1	Elapsed time for high data value
1	0	Elapsed time for low and high data values
1	1	Not Used

.3**Timer B Interrupt Enable Bit**

0	Disable Interrupt
1	Enable Interrupt

.2**Timer B Start/Stop Bit**

0	Stop timer B
1	Start timer B

.1**Timer B Mode Selection Bit**

0	One-shot mode
1	Repeating mode

.0**Timer B Output flip-flop Control Bit**

0	T-FF is low
1	T-FF is high

NOTE: fxx is selected clock for system.

TINTPND — Timer A, Timer 1 Interrupt Pending Register **E0H** **Set1, Bank1**

Bit Identifier	.7	.6	.5	.4	.3	.2	.1	.0
RESET VALUE	0	0	0	0	0	0	0	0
Read/Write	–	–	R/W	R/W	R/W	R/W	R/W	R/W
Addressing Mode	Register addressing mode only							

.7-.6 Not used for the S3C84H5/F84H5 (must keep always 0)

.5 **Timer 1(1) Overflow Interrupt Pending Bit**

0	No interrupt pending
0	<i>Clear pending bit when write</i>
1	Interrupt pending

.4 **Timer 1(1) Match/Capture Interrupt Pending Bit**

0	No interrupt pending
0	<i>Clear pending bit when write</i>
1	Interrupt pending

.3 **Timer 1(0) Overflow Interrupt Pending Bit**

0	No interrupt pending
0	<i>Clear pending bit when write</i>
1	Interrupt pending

.2 **Timer 1(0) Match/Capture Interrupt Pending Bit**

0	No interrupt pending
0	<i>Clear pending bit when write</i>
1	Interrupt pending

.1 **Timer A Overflow Interrupt Pending Bit**

0	No interrupt pending
0	<i>Clear pending bit when write</i>
1	Interrupt pending

.0 **Timer A Match/Capture Interrupt Pending Bit**

0	No interrupt pending
0	<i>Clear pending bit when write</i>
1	Interrupt pending

UARTCON — UART Control Register

F6H

Set1, Bank0

Bit Identifier	.7	.6	.5	.4	.3	.2	.1	.0
RESET Value	0	0	0	0	0	0	0	0
Read/Write	R/W	R/W	R/W	R/W	R/W	R/W	R/W	R/W

.7–.6**Operating mode and baud rate selection bits**

0	0	Mode 0: Shift Register [$f_{xx}/(16 \times (16\text{bit BRDATA} + 1))$]
0	1	Mode 1: 8-bit UART [$f_{xx}/(16 \times (16\text{bit BRDATA} + 1))$]
1	X	Mode 2: 9-bit UART [$f_{xx}/(16 \times (16\text{bit BRDATA} + 1))$]

.5**Multiprocessor communication⁽¹⁾ enable bit (for mode 2 only)**

0	Disable
1	Enable

.4**Serial data receive enable bit**

0	Disable
1	Enable

.3

If Parity disable mode (PEN = 0),
location of the 9th data bit to be transmitted in UART mode 2 ("0" or "1").

If Parity enable mode (PEN = 1),
even/odd parity selection bit for transmit data in UART mode 2.
0 : Even parity bit generation for transmit data
1 : Odd parity bit generation for transmit data

.2

If Parity disable (PEN = 0),
location of the 9th data bit that was received in UART mode 2 ("0" or "1").

If Parity enable mode (PEN = 1),
even/odd parity selection bit for receive data in UART mode 2.
0 : Even parity check for the received data
1 : Odd parity check for the received data

A result of parity error will be saved in RPE bit of the UARTPND register after parity checking of the received data.

UARTCON — UART Control Register (Continued)**F6H****Set1, Bank0****Bit Identifier****RESET Value****Read/Write**

.7	.6	.5	.4	.3	.2	.1	.0
0	0	0	0	0	0	0	0
R/W	R/W	R/W	R/W	R/W	R/W	R/W	R/W

.1**Receive interrupt enable bit**

0	Disable Receive interrupt
1	Enable Receive interrupt

.0**Transmit interrupt enable bit**

0	Disable Transmit interrupt
1	Enable Transmit Interrupt

NOTES:

1. In mode 2, if the MCE (UARTCON.5) bit is set to "1", then the receive interrupt will not be activated if the received 9th data bit is "0". In mode 1, if MCE = "1", then the receive interrupt will not be activated if a valid stop bit was not received. In mode 0, the MCE (UARTCON.5) bit should be "0".
2. The descriptions for 8-bit and 9-bit UART mode do not include start and stop bits for serial data receive and transmit.
3. Parity enable bits, PEN, are located in the UARTPND register at address F4H, bank 0.
4. Parity enable and parity error check can be available in 9-bit UART mode (Mode 2) only.

UARTPND — UART Pending and parity control

F4H

Set1, Bank0

Bit Identifier	.7	.6	.5	.4	.3	.2	.1	.0
RESET Value	0	0	0	0	0	0	0	0
Read/Write	–	–	R/W	R/W	–	–	R/W	R/W

.7-.6 Not used for the S3F84I5/F84I9(must keep always 0)

.5 **UART parity enable/disable (PEN)**

0	Disable
1	Enable

.4 **UART receive parity error (RPE)**

0	No error
1	Parity error

.3-.2 Not used for the S3F84I5/F84I9(must keep always 0)

.1 **UART receive interrupt pending flag**

0	Not pending
0	Clear pending bit (when write)
1	Interrupt pending

.0 **UART transmit interrupt pending flag**

0	Not pending
0	Clear pending bit (when write)
1	Interrupt pending

NOTES:

1. In order to clear a data transmit or receive interrupt pending flag, you must write a "0" to the appropriate pending bit.
2. To avoid programming errors, we recommend using load instruction (except for LDB), when manipulating UARTPND values.
3. Parity enable and parity error check can be available in 9-bit UART mode (Mode 2) only.
4. Parity error bit (RPE) will be refreshed whenever 8th receive data bit has been shifted.

WTCON — Watch Timer Control Register

F8H

Set1, Bank1

Bit Identifier	.7	.6	.5	.4	.3	.2	.1	.0
RESET Value	0	0	0	0	0	0	0	0
Read/Write	R/W	R/W	R/W	R/W	R/W	R/W	R/W	R/W
Addressing Mode	Register addressing mode only							

.7 **Watch Timer Clock Selection Bit**

0	Main system clock divided by 256 (fxx/256)
1	Sub system clock (fxt)

.6 **Watch Timer Interrupt Enable Bit**

0	Disable watch timer interrupt
1	Enable watch timer interrupt

.5–.4 **Buzzer Signal Selection Bits**

0	0	0.5 kHz buzzer (BZOUT) signal output
0	1	1 kHz buzzer (BZOUT) signal output
1	0	2 kHz buzzer (BZOUT) signal output
1	1	4 kHz buzzer (BZOUT) signal output

.3–.2 **Watch Timer Speed Selection Bits**

0	0	0.5 s Interval
0	1	0.25 s Interval
1	0	0.125 s Interval
1	1	1.955 ms Interval

.1 **Watch Timer Enable Bit**

0	Disable watch timer; Clear frequency dividing circuits
1	Enable watch timer

.0 **Watch Timer Interrupt Pending Bit**

0	Interrupt is not pending
1	Clear pending bit when write
1	Interrupt is pending

5

INTERRUPT STRUCTURE

OVERVIEW

The S3C8-series interrupt structure has three basic components: levels, vectors, and sources. The SAM8 CPU recognizes up to eight interrupt levels and supports up to 128 interrupt vectors. When a specific interrupt level has more than one vector address, the vector priorities are established in hardware. A vector address can be assigned to one or more sources.

Levels

Interrupt levels are the main unit for interrupt priority assignment and recognition. All peripherals and I/O blocks can issue interrupt requests. In other words, peripheral and I/O operations are interrupt-driven. There are eight possible interrupt levels: IRQ0–IRQ7, also called level 0–level 7. Each interrupt level directly corresponds to an interrupt request number (IRQn). The total number of interrupt levels used in the interrupt structure varies from device to device. The S3C84H5/F84H5 interrupt structure recognizes eight interrupt levels.

The interrupt level numbers 0 through 7 do not necessarily indicate the relative priority of the levels. They are just identifiers for the interrupt levels that are recognized by the CPU. The relative priority of different interrupt levels is determined by settings in the interrupt priority register, IPR. Interrupt group and subgroup logic controlled by IPR settings lets you define more complex priority relationships between different levels.

Vectors

Each interrupt level can have one or more interrupt vectors, or it may have no vector address assigned at all. The maximum number of vectors that can be supported for a given level is 128 (The actual number of vectors used for S3C8-series devices is always much smaller). If an interrupt level has more than one vector address, the vector priorities are set in hardware. S3C84H5/F84H5 uses sixteen vectors.

Sources

A source is any peripheral that generates an interrupt. A source can be an external pin or a counter overflow. Each vector can have several interrupt sources. In the S3C84H5/F84H5 interrupt structure, there are sixteen possible interrupt sources.

When a service routine starts, the respective pending bit should be either cleared automatically by hardware or cleared "manually" by program software. The characteristics of the source's pending mechanism determine which method would be used to clear its respective pending bit.

INTERRUPT TYPES

The three components of the S3C8 interrupt structure described before — levels, vectors, and sources — are combined to determine the interrupt structure of an individual device and to make full use of its available interrupt logic. There are three possible combinations of interrupt structure components, called interrupt types 1, 2, and 3. The types differ in the number of vectors and interrupt sources assigned to each level (see Figure 5-1):

- Type 1: One level (IRQ_n) + one vector (V₁) + one source (S₁)
- Type 2: One level (IRQ_n) + one vector (V₁) + multiple sources (S₁ – S_n)
- Type 3: One level (IRQ_n) + multiple vectors (V₁ – V_n) + multiple sources (S₁ – S_n, S_{n+1} – S_{n+m})

In the S3C84H5/F84H5 microcontroller, two interrupt types are implemented.

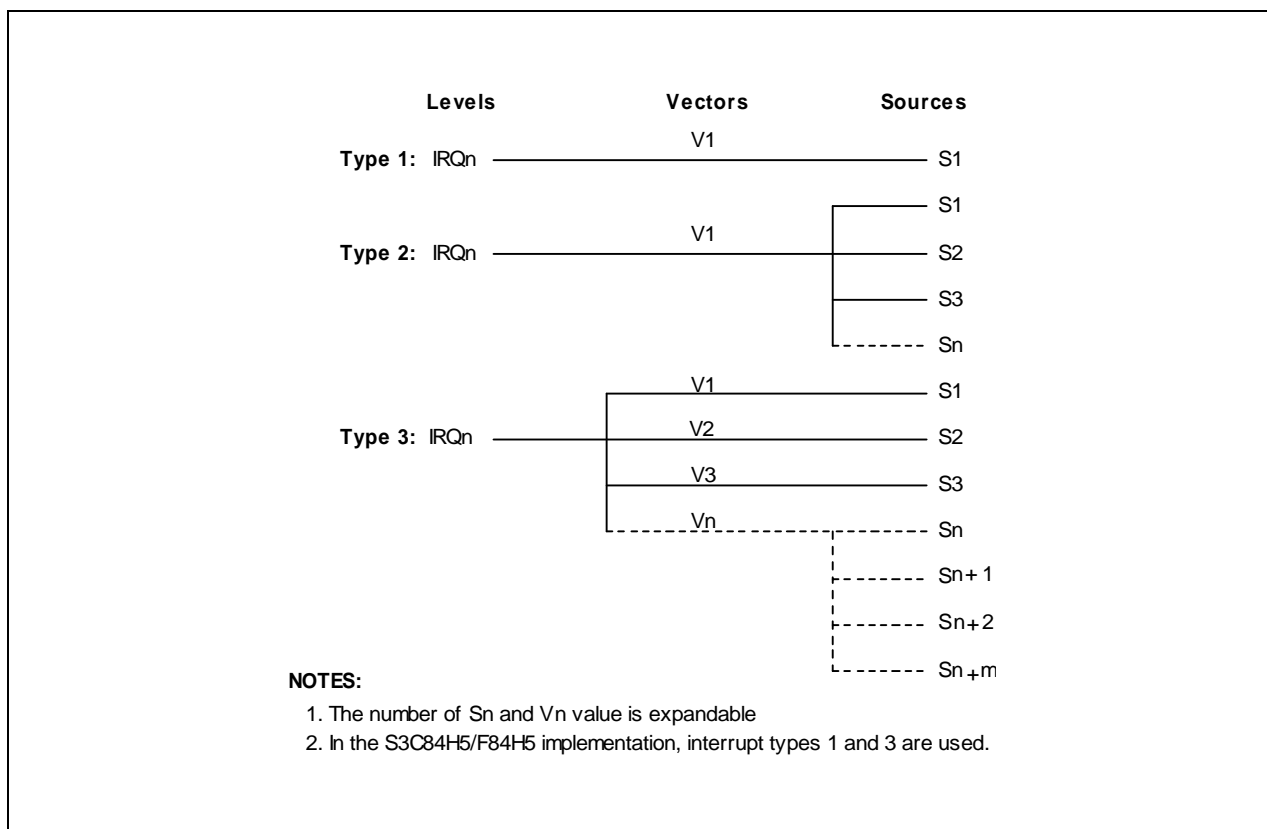


Figure 5-1. S3C8-Series Interrupt Types

S3C84H5/F84H5 INTERRUPT STRUCTURE

The S3C84H5/F84H5 microcontroller supports sixteen interrupt sources. All of the interrupt sources have a corresponding interrupt vector address. Eight interrupt levels are recognized by the CPU in this device-specific interrupt structure, as shown in Figure 5-2.

When multiple interrupt levels are active, the interrupt priority register (IPR) determines the order in which contending interrupts are to be serviced. If multiple interrupts occur within the same interrupt level, the interrupt with the lowest vector address is usually processed first (The relative priorities of multiple interrupts within a single level are fixed in hardware).

When the CPU grants an interrupt request, interrupt processing starts. All other interrupts are disabled and the program counter value and status flags are pushed to stack. The starting address of the service routine is fetched from the appropriate vector address (plus the next 8-bit value to concatenate the full 16-bit address) and the service routine is executed.

Levels	Vectors	Sources	Reset(Clear)
IRQ0	BEH	Timer B underflow	H/W
IRQ1	C0H	Timer A match/capture	H/W, S/W
	C2H	Timer A overflow	H/W, S/W
IRQ2	C4H	Timer 1(0) match/capture	H/W, S/W
	C6H	Timer 1(0) overflow	H/W, S/W
	C8H	Timer 1(1) match/capture	H/W, S/W
	CAH	Timer 1(1) overflow	H/W, S/W
IRQ3	CEH	P1.0 external interrupt	S/W
	D0H	P1.1 external interrupt	S/W
	D2H	P1.2 external interrupt	S/W
	D4H	P1.3 external interrupt	S/W
IRQ4	D6H	Watch timer	S/W
IRQ5	D8H	SIO receive/transmit	S/W
IRQ6	DAH	PWM overflow interrupt	S/W
IRQ7	DCH	UART data receive	S/W
	DEH	UART data transmit	S/W

NOTES:

1. Within a given interrupt level, the lower vector address has high priority. For example, DCH has higher priority than DEH within the level IRQ5 the priorities within each level are set at the factory.
2. External interrupts are triggered by a rising or falling edge, depending on the corresponding control register setting.

Figure 5-2. S3C84H5/F84H5Interrupt Structure

INTERRUPT VECTOR ADDRESSES

All interrupt vector addresses for the S3C84H5/F84H5 interrupt structure are stored in the vector address area of the internal 16-Kbyte ROM, 0H–3FFFH (see Figure 5-3).

You can allocate unused locations in the vector address area as normal program memory. If you do so, please be careful not to overwrite any of the stored vector addresses (Table 5-1 lists all vector addresses).

The program reset address in the ROM is 0100H.

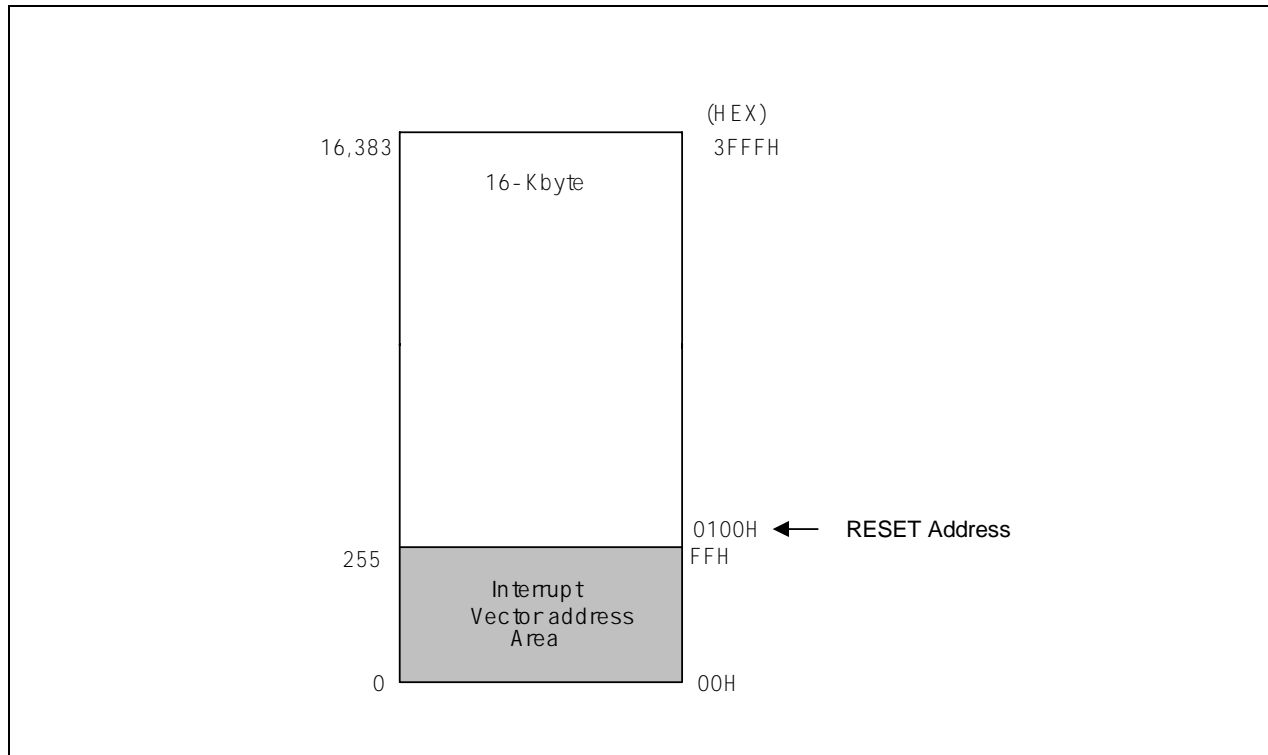


Figure 5-3. ROM Vector Address Area

Table 5-1. Interrupt Vectors

Vector Address		Interrupt Source	Request		Reset/Clear	
Decimal Value	Hex Value		Interrupt Level	Priority in Level	H/W	S/W
256	100H	Basic timer (WDT) overflow	nRESET	–	√	
222	DEH	UART transmit	IRQ7	1		√
220	DCH	UART receive		0		√
218	DAH	PWM overflow interrupt	IRQ6	–		√
216	D8H	SIO receive / transmit	IRQ5	–		√
214	D6H	Watch timer interrupt	IRQ4	–		√
212	D4H	P1.3 external interrupt	IRQ3	3		√
210	D2H	P1.2 external interrupt		2		√
208	D0H	P1.1 external interrupt		1		√
206	CEH	P1.0 external interrupt		0		√
202	CAH	Timer 1(1) overflow	IRQ2	3	√	√
200	C8H	Timer 1(1) match/capture		2	√	√
198	C6H	Timer 1(0) overflow		1	√	√
196	C4H	Timer 1(0) match/capture		0	√	√
194	C2H	Timer A overflow	IRQ1	1	√	√
192	C0H	Timer A match/capture		0	√	√
190	BEH	Timer B underflow	IRQ0	–	√	

NOTES:

1. Interrupt priorities are identified in inverse order: "0" is the highest priority, "1" is the next highest, and so on.
2. If two or more interrupts within the same level contend, the interrupt with the lowest vector address usually has priority over one with a higher vector address. The priorities within a given level are fixed in hardware.

ENABLE/DISABLE INTERRUPT INSTRUCTIONS (EI, DI)

Executing the Enable Interrupts (EI) instruction globally enables the interrupt structure. All interrupts are then serviced as they occur according to the established priorities.

NOTE

The system initialization routine executed after a reset must always contain an EI instruction to globally enable the interrupt structure.

During the normal operation, you can execute the DI (Disable Interrupt) instruction at any time to globally disable interrupt processing. The EI and DI instructions change the value of bit 0 in the SYM register.

SYSTEM-LEVEL INTERRUPT CONTROL REGISTERS

In addition to the control registers for specific interrupt sources, four system-level registers control interrupt processing:

- The interrupt mask register, IMR, enables (un-masks) or disables (masks) interrupt levels.
- The interrupt priority register, IPR, controls the relative priorities of interrupt levels.
- The interrupt request register, IRQ, contains interrupt pending flags for each interrupt level (as opposed to each interrupt source).
- The system mode register, SYM, enables or disables global interrupt processing (SYM settings also enable fast interrupts and control the activity of external interface, if implemented).

Table 5-2. Interrupt Control Register Overview

Control Register	ID	R/W	Function Description
Interrupt mask register	IMR	R/W	Bit settings in the IMR register enable or disable interrupt processing for each of the eight interrupt levels: IRQ0–IRQ7.
Interrupt priority register	IPR	R/W	Controls the relative processing priorities of the interrupt levels. The seven levels of S3F84I5/F84I9 are organized into three groups: A, B, and C. Group A is IRQ0 and IRQ1, group B is IRQ2, IRQ3 and IRQ4, and group C is IRQ5, IRQ6, and IRQ7.
Interrupt request register	IRQ	R	This register contains a request pending bit for each interrupt level.
System mode register	SYM	R/W	This register enables/disables fast interrupt processing, dynamic global interrupt processing.

NOTE: Before IMR register is changed to any value, all interrupts must be disabled. Using DI instruction is recommended.

INTERRUPT PROCESSING CONTROL POINTS

Interrupt processing can therefore be controlled in two ways: globally or by specific interrupt level and source. The system-level control points in the interrupt structure are:

- Global interrupt enable and disable (by EI and DI instructions or by direct manipulation of SYM.0)
- Interrupt level enable/disable settings (IMR register)
- Interrupt level priority settings (IPR register)
- Interrupt source enable/disable settings in the corresponding peripheral control registers

NOTE

When writing an application program that handles interrupt processing, be sure to include the necessary register file address (register pointer) information.

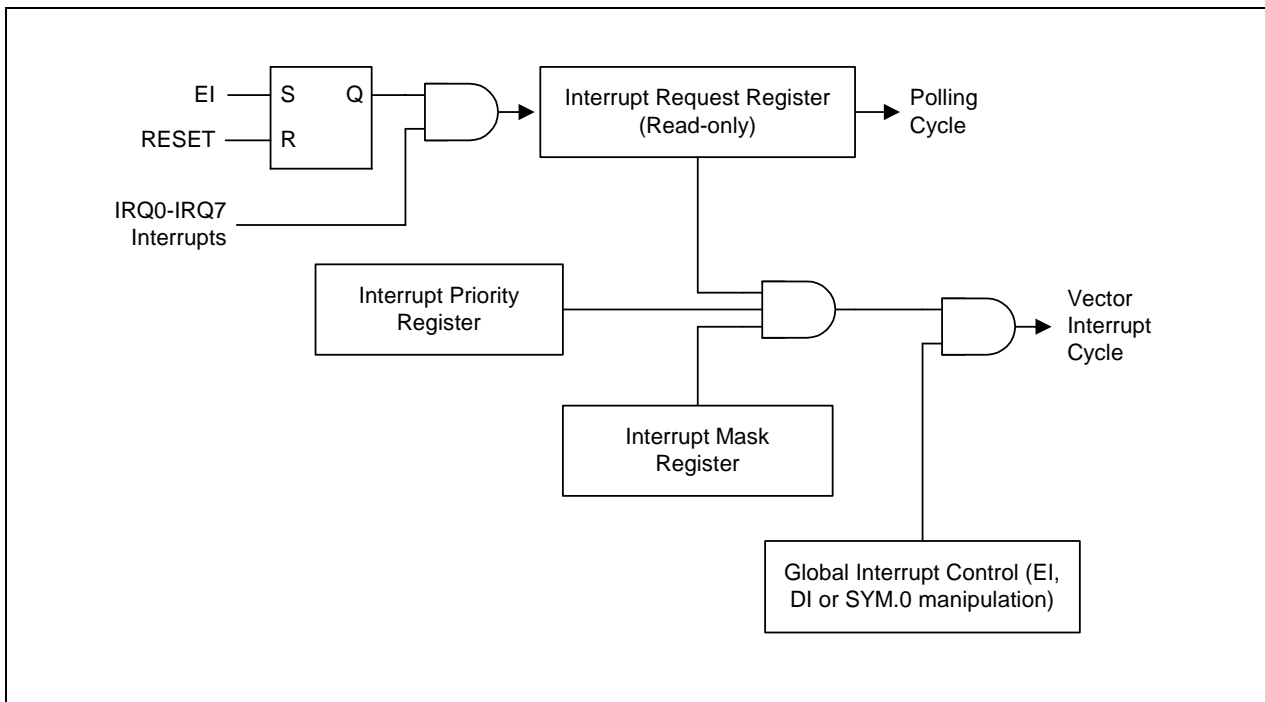


Figure 5-4. Interrupt Function Diagram

PERIPHERAL INTERRUPT CONTROL REGISTERS

For each interrupt source there is one or more corresponding peripheral control registers that let you control the interrupt generated by the related peripheral (see Table 5-3).

Table 5-3. Interrupt Source Control and Data Registers

Interrupt Source	Interrupt Level	Register(s)	Location(s) in set1
Timer B underflow	IRQ0	TBCON TBDATAH, TBDATAL	D0H D1H, D2H,
Timer A overflow Timer A match/capture	IRQ1	TINTPND TACON TADATA TACNT	E0H, bank 1 E1H, bank 1 E2H, bank 1 E3H, bank 1
Timer 1(0) match/capture Timer 1(0) overflow Timer 1(1) match/capture Timer 1(1) overflow	IRQ2	T1DATAH0, T1DATAL0 T1DATAH1, T1DATAL1 T1CON0, T1CON1 T1CNTH0, T1CNTL0 T1CNTH1, T1CNTL1 TINTPND	E4H, E5H, bank 1 E6H, E7H, bank 1 E8H, E9H, bank 1 EAH, EBH, bank 1 ECH, EDH, bank 1 E0H, bank 1
P1.0 external interrupt P1.1 external interrupt P1.2 external interrupt P1.3 external interrupt	IRQ3	P1CONL P1INT P1INTPND	E9H, bank 0 EBH, bank 0 EAH, bank 0 F3H, bank 0
Watch timer interrupt	IRQ4	WTCON	F8H, bank 1
SIO receive/transmit	IRQ5	SIOCON, SIODATA	F1H, F2H bank 1
PWM overflow	IRQ6	PWMCON PWMDATAH, PWMDATAL	F5H, bank 1 F3H, F4H bank 1
UART receive/transmit	IRQ7	UARTCON UDATA, UARTPND BRDATAH, BRDATAL	F6H, bank 0 F5H, F4H, bank 0 EEH, EFH, bank 1

SYSTEM MODE REGISTER (SYM)

The system mode register, SYM (set 1, DEH), is used to globally enable and disable interrupt processing (see Figure 5-5).

A reset clears SYM.0 to "0".

The instructions EI and DI enable and disable global interrupt processing, respectively, by modifying the bit 0 value of the SYM register. In order to enable interrupt processing an Enable Interrupt (EI) instruction must be included in the initialization routine, which follows a reset operation. Although you can manipulate SYM.0 directly to enable and disable interrupts during the normal operation, it is recommended to use the EI and DI instructions for this purpose.

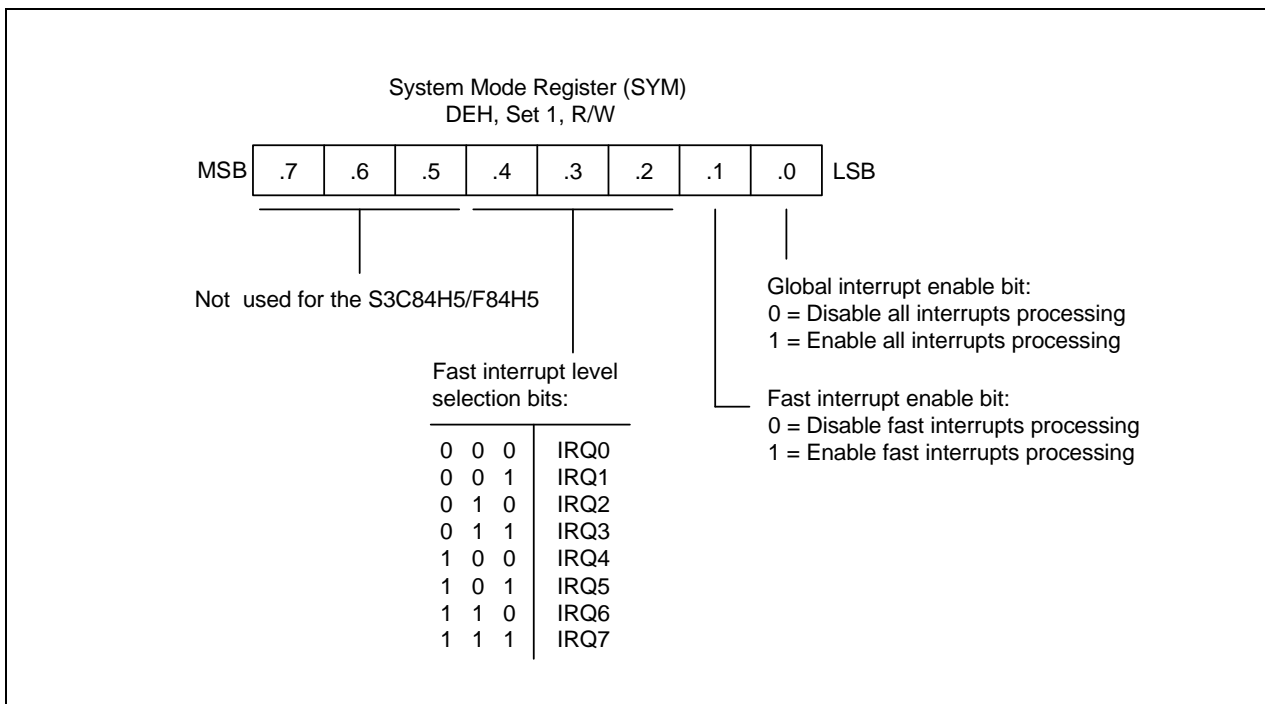


Figure 5-5. System Mode Register (SYM)

INTERRUPT MASK REGISTER (IMR)

The interrupt mask register, IMR (set 1, DDH) is used to enable or disable interrupt processing for individual interrupt levels. After a reset, all IMR bit values are undetermined and must therefore be written to their required settings by the initialization routine.

Each IMR bit corresponds to a specific interrupt level: bit 1 to IRQ1, bit 2 to IRQ2, and so on. When the IMR bit of an interrupt level is cleared to "0", interrupt processing for that level is disabled (masked). When you set a level's IMR bit to "1", interrupt processing for the level is enabled (not masked).

The IMR register is mapped to register location DDH in set 1. Bit values can be read and written by instructions using the Register addressing mode.

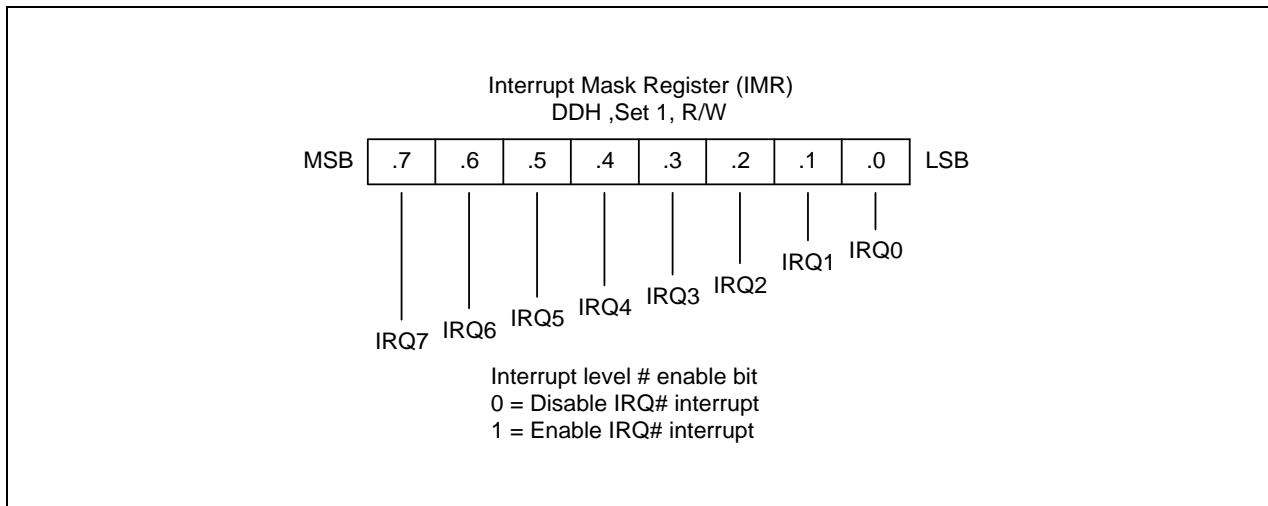


Figure 5-6. Interrupt Mask Register (IMR)

INTERRUPT PRIORITY REGISTER (IPR)

The interrupt priority register, IPR (set 1, bank 0, FFH), is used to set the relative priorities of the interrupt levels in the microcontroller's interrupt structure. After a reset, all IPR bit values are undetermined and must therefore be written to their required settings by the initialization routine.

When more than one interrupt sources are active, the source with the highest priority level is serviced first. If two sources belong to the same interrupt level, the source with the lower vector address usually has the priority (This priority is fixed in hardware).

To support programming of the relative interrupt level priorities, they are organized into groups and subgroups by the interrupt logic. Please note that these groups (and subgroups) are used only by IPR logic for the IPR register priority definitions (see Figure 5-7):

- Group A IRQ0, IRQ1
- Group B IRQ2, IRQ3, IRQ4
- Group C IRQ5, IRQ6, IRQ7

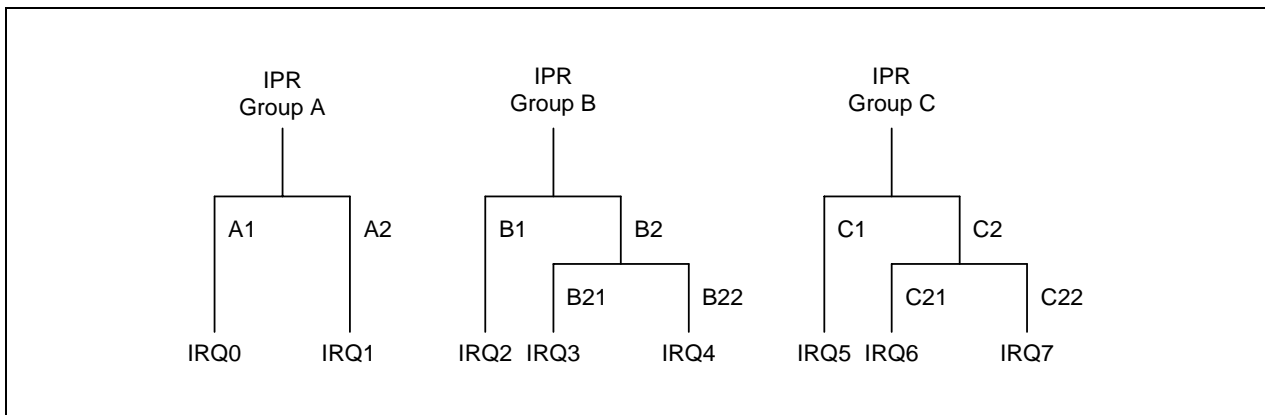


Figure 5-7. Interrupt Request Priority Groups

As you can see in Figure 5-8, IPR.7, IPR.4, and IPR.1 control the relative priority of interrupt groups A, B, and C. For example, the setting "001B" for these bits would select the group relationship $B > C > A$. The setting "101B" would select the relationship $C > B > A$.

The functions of the other IPR bit settings are as follows:

- IPR.5 controls the relative priorities of group C interrupts.
- Interrupt group C includes a subgroup that has an additional priority relationship among the interrupt levels 5, 6, and 7. IPR.6 defines the subgroup C relationship. IPR.5 controls the interrupt group C.
- IPR.0 controls the relative priority setting of IRQ0 and IRQ1 interrupts.

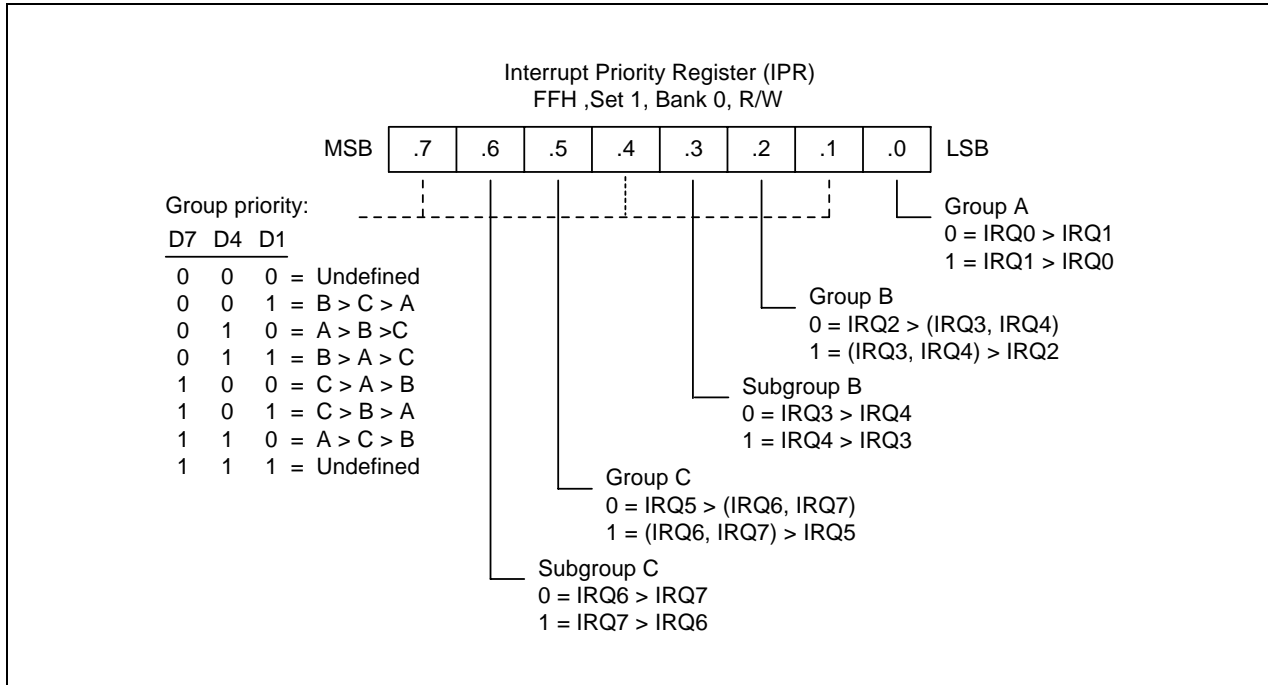


Figure 5-8. Interrupt Priority Register (IPR)

INTERRUPT REQUEST REGISTER (IRQ)

You can poll bit values in the interrupt request register, IRQ (set 1, DCH), to monitor interrupt request status for all levels in the microcontroller's interrupt structure. Each bit corresponds to the interrupt level of the same number: bit 0 to IRQ0, bit 1 to IRQ1, and so on. A "0" indicates that no interrupt request is currently being issued for that level. A "1" indicates that an interrupt request has been generated for that level.

IRQ bit values are read-only addressable using Register addressing mode. You can read (test) the contents of the IRQ register at any time using bit or byte addressing to determine the current interrupt request status of specific interrupt levels. After a reset, all IRQ status bits are cleared to "0".

You can poll IRQ register values even if a DI instruction has been executed (that is, if global interrupt processing is disabled). If an interrupt occurs while the interrupt structure is disabled, the CPU will not service it. You can, however, still detect the interrupt request by polling the IRQ register. In this way, you can determine which events occurred while the interrupt structure was globally disabled.

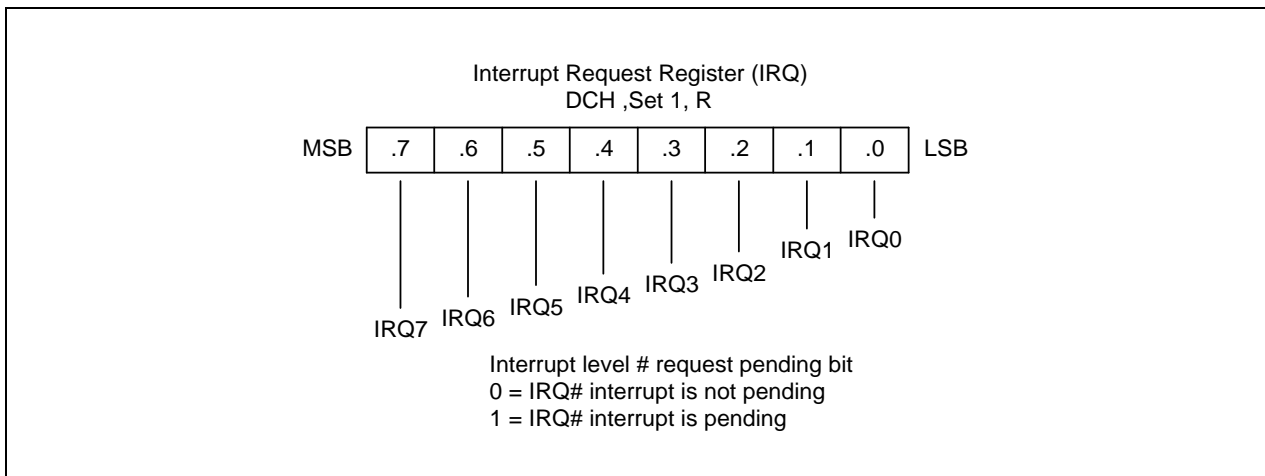


Figure 5-9. Interrupt Request Register (IRQ)

INTERRUPT PENDING FUNCTION TYPES

Overview

There are two types of interrupt pending bits: one type that is automatically cleared by hardware after the interrupt service routine is acknowledged and executed; the other that must be cleared in the interrupt service routine.

Pending Bits Cleared Automatically by Hardware

For interrupt pending bits that are cleared automatically by hardware, interrupt logic sets the corresponding pending bit to "1" when a request occurs. It then issues an IRQ pulse to inform the CPU that an interrupt is waiting to be serviced. The CPU acknowledges the interrupt source by sending an IACK, executes the service routine, and clears the pending bit to "0". This type of pending bit is not mapped and cannot, therefore, be read or written by application software.

In the S3C84H5/F84H5 interrupt structure, the timer B underflow interrupt (IRQ0) belongs to this category of interrupts in which pending condition is cleared automatically by hardware.

Pending Bits Cleared by the Service Routine

The second type of pending bit is the one that should be cleared by program software. The service routine must clear the appropriate pending bit before a return-from-interrupt subroutine (IRET) occurs. To do this, a "0" must be written to the corresponding pending bit location in the source's mode or control register.

In the S3C84H5/F84H5 interrupt structure, pending conditions for IRQ3, IRQ4, IRQ5, IRQ6, and IRQ7 must be cleared in the interrupt service routine.

INTERRUPT SOURCE POLLING SEQUENCE

The interrupt request polling and servicing sequence is as follows:

1. A source generates an interrupt request by setting the interrupt request bit to "1".
2. The CPU polling procedure identifies a pending condition for that source.
3. The CPU checks the interrupt level of source.
4. The CPU generates an interrupt acknowledge signal.
5. Interrupt logic determines the interrupt's vector address.
6. The service routine starts and the source's pending bit is cleared to "0" (by hardware or by software).
7. The CPU continues polling for interrupt requests.

INTERRUPT SERVICE ROUTINES

Before an interrupt request is serviced, the following conditions must be met:

- Interrupt processing must be globally enabled (EI, SYM.0 = "1")
- The interrupt level must be enabled (IMR register)
- The interrupt level must have the highest priority if more than one level is currently requesting service
- The interrupt must be enabled at the interrupt's source (peripheral control register)

When all the above conditions are met, the interrupt request is acknowledged at the end of the instruction cycle. The CPU then initiates an interrupt machine cycle that completes the following processing sequence:

1. Reset (clear to "0") the interrupt enable bit in the SYM register (SYM.0) to disable all subsequent interrupts.
2. Save the program counter (PC) and status flags to the system stack.
3. Branch to the interrupt vector to fetch the address of the service routine.
4. Pass control to the interrupt service routine.

When the interrupt service routine is completed, the CPU issues an Interrupt Return (IRET). The IRET restores the PC and status flags, setting SYM.0 to "1". It allows the CPU to process the next interrupt request.

GENERATING INTERRUPT VECTOR ADDRESSES

The interrupt vector area in the ROM (00H–FFH) contains the addresses of interrupt service routines that correspond to each level in the interrupt structure. Vectored interrupt processing follows this sequence:

1. Push the program counter's low-byte value to the stack.
2. Push the program counter's high-byte value to the stack.
3. Push the FLAG register values to the stack.
4. Fetch the service routine's high-byte address from the vector location.
5. Fetch the service routine's low-byte address from the vector location.
6. Branch to the service routine specified by the concatenated 16-bit vector address.

NOTE

A 16-bit vector address always begins at an even-numbered ROM address within the range of 00H–FFH.

NESTING OF VECTORED INTERRUPTS

It is possible to nest a higher-priority interrupt request while a lower-priority request is being serviced. To do this, you must follow these steps:

1. Push the current 8-bit interrupt mask register (IMR) value to the stack (PUSH IMR).
2. Load the IMR register with a new mask value that enables only the higher priority interrupt.
3. Execute an EI instruction to enable interrupt processing (a higher priority interrupt will be processed if it occurs).
4. When the lower-priority interrupt service routine ends, restore the IMR to its original value by returning the previous mask value from the stack (POP IMR).
5. Execute an IRET.

Depending on the application, you may be able to simplify the procedure above to some extent.

6

INSTRUCTION SET

OVERVIEW

The instruction set is specifically designed to support large register files that are typical of most S3C8-series microcontrollers. There are 78 instructions. The powerful data manipulation capabilities and features of the instruction set include:

- A full complement of 8-bit arithmetic and logic operations, including multiply and divide
- No special I/O instructions (I/O control/data registers are mapped directly into the register file)
- Decimal adjustment included in binary-coded decimal (BCD) operations
- 16-bit (word) data can be incremented and decremented
- Flexible instructions for bit addressing, rotate, and shift operations

DATA TYPES

The CPU performs operations on bits, bytes, BCD digits, and two-byte words. Bits in the register file can be set, cleared, complemented, and tested. Bits within a byte are numbered from 7 to 0, where bit 0 is the least significant (right-most) bit.

REGISTER ADDRESSING

To access an individual register, an 8-bit address in the range 0–255 or the 4-bit address of a working register is specified. Paired registers can be used to construct 16-bit data, 16-bit program memory or data memory addresses. For detailed information about register addressing, please refer to Chapter 2, "Address Spaces."

ADDRESSING MODES

There are seven explicit addressing modes: Register (R), Indirect Register (IR), Indexed (X), Direct (DA), Relative (RA), Immediate (IM), and Indirect (IA). For detailed descriptions of these addressing modes, please refer to Chapter 3, "Addressing Modes."

Table 6-1. Instruction Group Summary

Mnemonic	Operands	Instruction
Load Instructions		
CLR	dst	Clear
LD	dst,src	Load
LDB	dst,src	Load bit
LDE	dst,src	Load external data memory
LDC	dst,src	Load program memory
LDED	dst,src	Load external data memory and decrement
LDCD	dst,src	Load program memory and decrement
LDEI	dst,src	Load external data memory and increment
LDCI	dst,src	Load program memory and increment
LDEPD	dst,src	Load external data memory with pre-decrement
LDCPD	dst,src	Load program memory with pre-decrement
LDEPI	dst,src	Load external data memory with pre-increment
LDCPI	dst,src	Load program memory with pre-increment
LDW	dst,src	Load word
POP	dst	Pop from stack
POPUD	dst,src	Pop user stack (decrementing)
POPUI	dst,src	Pop user stack (incrementing)
PUSH	src	Push to stack
PUSHUD	dst,src	Push user stack (decrementing)
PUSHUI	dst,src	Push user stack (incrementing)

NOTE: LDE, LDED, LDEI, LDEPP, and LDEPI instructions can be used to read/write the data from the 64-Kbyte data memory.

Table 6-1. Instruction Group Summary (Continued)

Mnemonic	Operands	Instruction
Arithmetic Instructions		
ADC	dst,src	Add with carry
ADD	dst,src	Add
CP	dst,src	Compare
DA	dst	Decimal adjust
DEC	dst	Decrement
DECW	dst	Decrement word
DIV	dst,src	Divide
INC	dst	Increment
INCW	dst	Increment word
MULT	dst,src	Multiply
SBC	dst,src	Subtract with carry
SUB	dst,src	Subtract
Logic Instructions		
AND	dst,src	Logical AND
COM	dst	Complement
OR	dst,src	Logical OR
XOR	dst,src	Logical exclusive OR

Table 6-1. Instruction Group Summary (Continued)

Mnemonic	Operands	Instruction
Program Control Instructions		
BTJRF	dst,src	Bit test and jump relative on false
BTJRT	dst,src	Bit test and jump relative on true
CALL	dst	Call procedure
CPIJE	dst,src	Compare, increment and jump on equal
CPIJNE	dst,src	Compare, increment and jump on non-equal
DJNZ	r,dst	Decrement register and jump on non-zero
ENTER		Enter
EXIT		Exit
IRET		Interrupt return
JP	cc,dst	Jump on condition code
JP	dst	Jump unconditional
JR	cc,dst	Jump relative on condition code
NEXT		Next
RET		Return
WFI		Wait for interrupt
Bit Manipulation Instructions		
BAND	dst,src	Bit AND
BCP	dst,src	Bit compare
BITC	dst	Bit complement
BITR	dst	Bit reset
BITS	dst	Bit set
BOR	dst,src	Bit OR
BXOR	dst,src	Bit XOR
TCM	dst,src	Test complement under mask
TM	dst,src	Test under mask

Table 6-1. Instruction Group Summary (Concluded)

Mnemonic	Operands	Instruction
Rotate and Shift Instructions		
RL	dst	Rotate left
RLC	dst	Rotate left through carry
RR	dst	Rotate right
RRC	dst	Rotate right through carry
SRA	dst	Shift right arithmetic
SWAP	dst	Swap nibbles
CPU Control Instructions		
CCF		Complement carry flag
DI		Disable interrupts
EI		Enable interrupts
IDLE		Enter Idle mode
NOP		No operation
RCF		Reset carry flag
SB0		Set bank 0
SB1		Set bank 1
SCF		Set carry flag
SRP	src	Set register pointers
SRP0	src	Set register pointer 0
SRP1	src	Set register pointer 1
STOP		Enter Stop mode

FLAGS REGISTER (FLAGS)

The flags register FLAGS contains eight bits which describe the current status of CPU operations. Four of these bits, FLAGS.7–FLAGS.4, can be tested and used with conditional jump instructions. Two other flag bits, FLAGS.3 and FLAGS.2, are used for BCD arithmetic.

The FLAGS register also contains a bit to indicate the status of fast interrupt processing (FLAGS.1) and a bank address status bit (FLAGS.0) to indicate whether register bank 0 or bank 1 is currently being addressed.

FLAGS register can be set or reset by instructions as long as its outcome does not affect the flags, such as, Load instruction. Logical and Arithmetic instructions such as, AND, OR, XOR, ADD, and SUB can affect the Flags register. For example, the AND instruction updates the Zero, Sign and Overflow flags based on the outcome of the AND instruction. If the AND instruction uses the Flags register as the destination, then two write will simultaneously occur to the Flags register producing an unpredictable result.

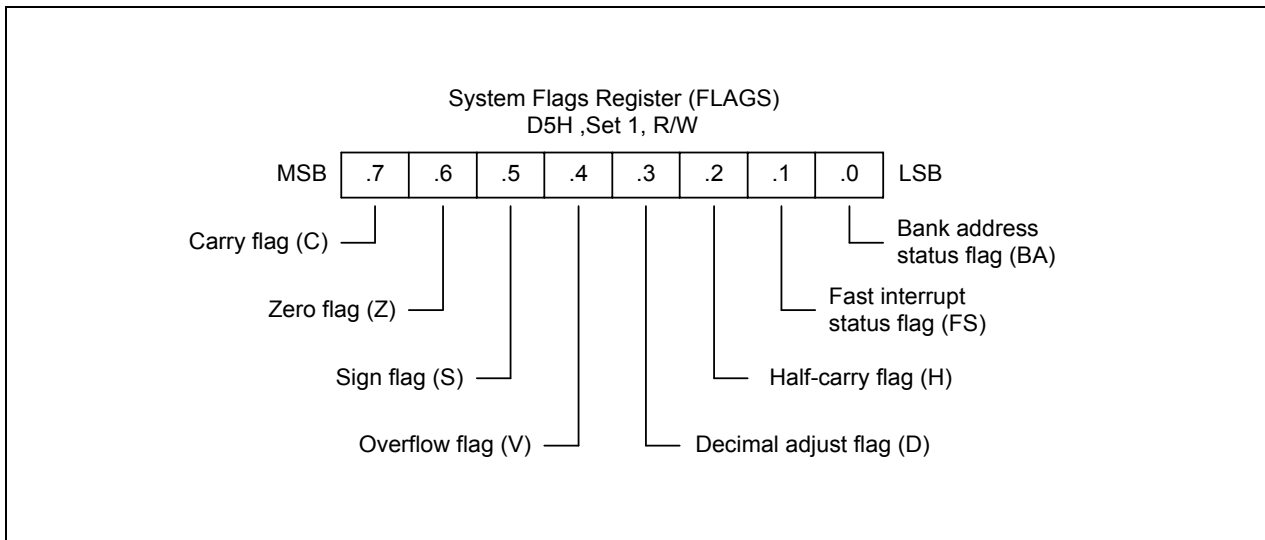


Figure 6-1. System Flags Register (FLAGS)

FLAG DESCRIPTIONS**C Carry Flag (FLAGS.7)**

The C flag is set to "1" if the result from an arithmetic operation generates a carry-out from or a borrow to the bit 7 position (MSB). After rotate and shift operations have been performed, it contains the last value shifted out of the specified register. Program instructions can set, clear, or complement the carry flag.

Z Zero Flag (FLAGS.6)

For arithmetic and logic operations, the Z flag is set to "1" if the result of the operation is zero. In operations that test register bits, and in shift and rotate operations, the Z flag is set to "1" if the result is logic zero.

S Sign Flag (FLAGS.5)

Following arithmetic, logic, rotate, or shift operations, the sign bit identifies the state of the MSB of the result. A logic zero indicates a positive number and a logic one indicates a negative number.

V Overflow Flag (FLAGS.4)

The V flag is set to "1" when the result of a two's-complement operation is greater than + 127 or less than - 128. It is cleared to "0" after a logic operation has been performed.

D Decimal Adjust Flag (FLAGS.3)

The DA bit is used to specify what type of instruction was executed last during BCD operations so that a subsequent decimal adjust operation can execute correctly. The DA bit is not usually accessed by programmers, and it cannot be addressed as a test condition.

H Half-Carry Flag (FLAGS.2)

The H bit is set to "1" whenever an addition generates a carry-out of bit 3, or when a subtraction borrows out of bit 4. It is used by the Decimal Adjust (DA) instruction to convert the binary result of a previous addition or subtraction into the correct decimal (BCD) result. The H flag is normally not accessed directly by a program.

FIS Fast Interrupt Status Flag (FLAGS.1)

The FIS bit is set during a fast interrupt cycle and reset during the IRET following interrupt servicing. When set, it inhibits all interrupts and causes the fast interrupt return to be executed when the IRET instruction is executed.

BA Bank Address Flag (FLAGS.0)

The BA flag indicates which register bank in the set 1 area of the internal register file is currently selected, bank 0 or bank 1. The BA flag is cleared to "0" (select bank 0) when the SB0 instruction is executed and is set to "1" (select bank 1) when the SB1 instruction is executed.

INSTRUCTION SET NOTATION

Table 6-2. Flag Notation Conventions

Flag	Description
C	Carry flag
Z	Zero flag
S	Sign flag
V	Overflow flag
D	Decimal-adjust flag
H	Half-carry flag
0	Cleared to logic zero
1	Set to logic one
*	Set or cleared according to operation
–	Value is unaffected
x	Value is undefined

Table 6-3. Instruction Set Symbols

Symbol	Description
dst	Destination operand
src	Source operand
@	Indirect register address prefix
PC	Program counter
IP	Instruction pointer
FLAGS	Flags register (D5H)
RP	Register pointer
#	Immediate operand or register address prefix
H	Hexadecimal number suffix
D	Decimal number suffix
B	Binary number suffix
opc	Opcode

Table 6-4. Instruction Notation Conventions

Notation	Description	Actual Operand Range
cc	Condition code	See list of condition codes in Table 6-6.
r	Working register only	Rn (n = 0–15)
rb	Bit (b) of working register	Rn.b (n = 0–15, b = 0–7)
r0	Bit 0 (LSB) of working register	Rn (n = 0–15)
rr	Working register pair	RRp (p = 0, 2, 4, ..., 14)
R	Register or working register	reg or Rn (reg = 0–255, n = 0–15)
Rb	Bit "b" of register or working register	reg.b (reg = 0–255, b = 0–7)
RR	Register pair or working register pair	reg or RRp (reg = 0–254, even number only, where p = 0, 2, ..., 14)
IA	Indirect addressing mode	addr (addr = 0–254, even number only)
Ir	Indirect working register only	@Rn (n = 0–15)
IR	Indirect register or indirect working register	@Rn or @reg (reg = 0–255, n = 0–15)
Irr	Indirect working register pair only	@RRp (p = 0, 2, ..., 14)
IRR	Indirect register pair or indirect working register pair	@RRp or @reg (reg = 0–254, even only, where p = 0, 2, ..., 14)
X	Indexed addressing mode	#reg[Rn] (reg = 0–255, n = 0–15)
XS	Indexed (short offset) addressing mode	#addr[RRp] (addr = range –128 to +127, where p = 0, 2, ..., 14)
XL	Indexed (long offset) addressing mode	#addr [RRp] (addr = range 0–65535, where p = 2, ..., 14)
DA	Direct addressing mode	addr (addr = range 0–65535)
RA	Relative addressing mode	addr (addr = a number from +127 to –128 that is an offset relative to the address of the next instruction)
IM	Immediate addressing mode	#data (data = 0–255)
IML	Immediate (long) addressing mode	#data (data = 0–65535)

Table 6-5. OPCODE Quick Reference

OPCODE MAP									
LOWER NIBBLE (HEX)									
	-	0	1	2	3	4	5	6	7
U	0	DEC R1	DEC IR1	ADD r1,r2	ADD r1,lr2	ADD R2,R1	ADD IR2,R1	ADD R1,IM	BOR r0-Rb
P	1	RLC R1	RLC IR1	ADC r1,r2	ADC r1,lr2	ADC R2,R1	ADC IR2,R1	ADC R1,IM	BCP r1.b, R2
P	2	INC R1	INC IR1	SUB r1,r2	SUB r1,lr2	SUB R2,R1	SUB IR2,R1	SUB R1,IM	BXOR r0-Rb
E	3	JP IRR1	SRP/0/1 IM	SBC r1,r2	SBC r1,lr2	SBC R2,R1	SBC IR2,R1	SBC R1,IM	BTJR r2.b, RA
R	4	DA R1	DA IR1	OR r1,r2	OR r1,lr2	OR R2,R1	OR IR2,R1	OR R1,IM	LDB r0-Rb
	5	POP R1	POP IR1	AND r1,r2	AND r1,lr2	AND R2,R1	AND IR2,R1	AND R1,IM	BITC r1.b
N	6	COM R1	COM IR1	TCM r1,r2	TCM r1,lr2	TCM R2,R1	TCM IR2,R1	TCM R1,IM	BAND r0-Rb
I	7	PUSH R2	PUSH IR2	TM r1,r2	TM r1,lr2	TM R2,R1	TM IR2,R1	TM R1,IM	BIT r1.b
B	8	DECW RR1	DECW IR1	PUSHUD IR1,R2	PUSHUI IR1,R2	MULT R2,RR1	MULT IR2,RR1	MULT IM,RR1	LD r1, x, r2
B	9	RL R1	RL IR1	POPUD IR2,R1	POPUI IR2,R1	DIV R2,RR1	DIV IR2,RR1	DIV IM,RR1	LD r2, x, r1
L	A	INCW RR1	INCW IR1	CP r1,r2	CP r1,lr2	CP R2,R1	CP IR2,R1	CP R1,IM	LDC r1, lrr2, xL
E	B	CLR R1	CLR IR1	XOR r1,r2	XOR r1,lr2	XOR R2,R1	XOR IR2,R1	XOR R1,IM	LDC r2, lrr2, xL
	C	RRC R1	RRC IR1	CPIJE lr,r2,RA	LDC r1,lr2	LDW RR2,RR1	LDW IR2,RR1	LDW RR1,IML	LD r1, lr2
H	D	SRA R1	SRA IR1	CPIJNE lrr,r2,RA	LDC r2,lr1	CALL IA1		LD IR1,IM	LD lr1, r2
E	E	RR R1	RR IR1	LDCD r1,lrr2	LDCI r1,lr2	LD R2,R1	LD R2,IR1	LD R1,IM	LDC r1, lrr2, xs
X	F	SWAP R1	SWAP IR1	LDCPD r2,lrr1	LDCPI r2,lr1	CALL IRR1	LD IR2,R1	CALL DA1	LDC r2, lrr1, xs

Table 6-5. OPCODE Quick Reference (Continued)

OPCODE MAP									
LOWER NIBBLE (HEX)									
	-	8	9	A	B	C	D	E	F
U	0	LD r1,R2	LD r2,R1	DJNZ r1,RA	JR cc,RA	LD r1,IM	JP cc,DA	INC r1	NEXT
P	1	↓	↓	↓	↓	↓	↓	↓	ENTER
P	2								EXIT
E	3								WFI
R	4								SB0
	5								SB1
N	6								IDLE
I	7	↓	↓	↓	↓	↓	↓	↓	STOP
B	8								DI
B	9								EI
L	A								RET
E	B								IRET
	C								RCF
H	D	↓	↓	↓	↓	↓	↓	↓	SCF
E	E								CCF
X	F	LD r1,R2	LD r2,R1	DJNZ r1,RA	JR cc,RA	LD r1,IM	JP cc,DA	INC r1	NOP

CONDITION CODES

The opcode of a conditional jump always contains a 4-bit field called the condition code (cc). This specifies under which conditions it is to execute the jump. For example, a conditional jump with the condition code for "equal" after a compare operation only jumps if the two operands are equal. Condition codes are listed in Table 6-6.

The carry (C), zero (Z), sign (S), and overflow (V) flags are used to control the operation of conditional jump instructions.

Table 6-6. Condition Codes

Binary	Mnemonic	Description	Flags Set
0000	F	Always false	–
1000	T	Always true	–
0111 (1)	C	Carry	C = 1
1111 (1)	NC	No carry	C = 0
0110 (1)	Z	Zero	Z = 1
1110 (1)	NZ	Not zero	Z = 0
1101	PL	Plus	S = 0
0101	MI	Minus	S = 1
0100	OV	Overflow	V = 1
1100	NOV	No overflow	V = 0
0110 (1)	EQ	Equal	Z = 1
1110 (1)	NE	Not equal	Z = 0
1001	GE	Greater than or equal	(S XOR V) = 0
0001	LT	Less than	(S XOR V) = 1
1010	GT	Greater than	(Z OR (S XOR V)) = 0
0010	LE	Less than or equal	(Z OR (S XOR V)) = 1
1111 (1)	UGE	Unsigned greater than or equal	C = 0
0111 (1)	ULT	Unsigned less than	C = 1
1011	UGT	Unsigned greater than	(C = 0 AND Z = 0) = 1
0011	ULE	Unsigned less than or equal	(C OR Z) = 1

NOTES:

1. It indicate condition codes which are related to two different mnemonics but which test the same flag. For example, Z and EQ are both true if the zero flag (Z) is set, but after an ADD instruction, Z would probably be used. Following a CP instruction, you would probably want to use the instruction EQ.
2. For operations using unsigned numbers, the special condition codes UGE, ULT, UGT, and ULE must be used.

INSTRUCTION DESCRIPTIONS

This Chapter contains detailed information and programming examples for each instruction in the S3C8-series instruction set. Information is arranged in a consistent format for improved readability and for quick reference. The following information is included in each instruction description:

- Instruction name (mnemonic)
- Full instruction name
- Source/destination format of the instruction operand
- Shorthand notation of the instruction's operation
- Textual description of the instruction's effect
- Flag settings that may be affected by the instruction
- Detailed description of the instruction's format, execution time, and addressing mode(s)
- Programming example(s) explaining how to use the instruction

ADC — Add with Carry

ADC dst,src

Operation: $dst \leftarrow dst + src + c$

The source operand, along with the carry flag setting, is added to the destination operand and the sum is stored in the destination. The contents of the source are unaffected. Two's-complement addition is performed. In multiple-precision arithmetic, this instruction lets the carry value from the addition of low-order operands be carried into the addition of high-order operands.

Flags:

- C:** Set if there is a carry from the most significant bit of the result; cleared otherwise.
- Z:** Set if the result is "0"; cleared otherwise.
- S:** Set if the result is negative; cleared otherwise.
- V:** Set if arithmetic overflow occurs, that is, if both operands are of the same sign and the result is of the opposite sign; cleared otherwise.
- D:** Always cleared to "0".
- H:** Set if there is a carry from the most significant bit of the low-order four bits of the result; cleared otherwise.

Format:

		Bytes	Cycles	Opcode (Hex)	Addr Mode <u>dst</u> <u>src</u>
opc	dst src	2	4	12	r r
			6	13	r lr
opc	src dst	3	6	14	R R
				15	R IR
opc	dst src	3	6	16	R IM

Examples: Given: R1 = 10H, R2 = 03H, C flag = "1", register 01H = 20H, register 02H = 03H, and register 03H = 0AH:

```

ADC   R1,R2    →   R1 = 14H, R2 = 03H
ADC   R1,@R2   →   R1 = 1BH, R2 = 03H
ADC   01H,02H  →   Register 01H = 24H, register 02H = 03H
ADC   01H,@02H →   Register 01H = 2BH, register 02H = 03H
ADC   01H,#11H →   Register 01H = 32H

```

In the first example, the destination register R1 contains the value 10H, the carry flag is set to "1" and the source working register R2 contains the value 03H. The statement "ADC R1,R2" adds 03H and the carry flag value ("1") to the destination value 10H, leaving 14H in the register R1.

ADD — Add

ADD dst,src

Operation: $dst \leftarrow dst + src$

The source operand is added to the destination operand and the sum is stored in the destination. The contents of the source are unaffected. Two's-complement addition is performed.

Flags:

- C:** Set if there is a carry from the most significant bit of the result; cleared otherwise.
- Z:** Set if the result is "0"; cleared otherwise.
- S:** Set if the result is negative; cleared otherwise.
- V:** Set if arithmetic overflow occurred, that is, if both operands are of the same sign and the result is of the opposite sign; cleared otherwise.
- D:** Always cleared to "0".
- H:** Set if a carry from the low-order nibble occurred.

Format:

			Bytes	Cycles	Opcode (Hex)	Addr Mode <u>dst</u> <u>src</u>
opc	dst src		2	4	02	r r
				6	03	r lr
opc	src	dst	3	6	04	R R
					05	R IR
opc	dst	src	3	6	06	R IM

Examples: Given: R1 = 12H, R2 = 03H, register 01H = 21H, register 02H = 03H, register 03H = 0AH:

```

ADD    R1,R2    →    R1 = 15H, R2 = 03H
ADD    R1,@R2   →    R1 = 1CH, R2 = 03H
ADD    01H,02H  →    Register 01H = 24H, register 02H = 03H
ADD    01H,@02H →    Register 01H = 2BH, register 02H = 03H
ADD    01H,#25H →    Register 01H = 46H

```

In the first example, the destination working register R1 contains 12H and the source working register R2 contains 03H. The statement "ADD R1,R2" adds 03H to 12H, leaving the value 15H in the register R1.

AND — Logical AND

AND dst,src

Operation: dst ← dst AND src

The source operand is logically ANDed with the destination operand. The result is stored in the destination. The AND operation causes a "1" bit to be stored whenever the corresponding bits in the two operands are both logic ones; otherwise a "0" bit value is stored. The contents of the source are unaffected.

Flags:

- C:** Unaffected.
- Z:** Set if the result is "0"; cleared otherwise.
- S:** Set if the result bit 7 is set; cleared otherwise.
- V:** Always cleared to "0".
- D:** Unaffected.
- H:** Unaffected.

Format:

			Bytes	Cycles	Opcode (Hex)	Addr Mode <u>dst</u> <u>src</u>
<div style="border: 1px solid black; padding: 2px; display: inline-block; margin-right: 5px;">opc</div> <div style="border: 1px solid black; padding: 2px; display: inline-block;">dst src</div>			2	4	52	r r
				6	53	r lr
<div style="border: 1px solid black; padding: 2px; display: inline-block; margin-right: 5px;">opc</div> <div style="border: 1px solid black; padding: 2px; display: inline-block; margin-right: 5px;">src</div> <div style="border: 1px solid black; padding: 2px; display: inline-block;">dst</div>			3	6	54	R R
				6	55	R IR
<div style="border: 1px solid black; padding: 2px; display: inline-block; margin-right: 5px;">opc</div> <div style="border: 1px solid black; padding: 2px; display: inline-block; margin-right: 5px;">dst</div> <div style="border: 1px solid black; padding: 2px; display: inline-block;">src</div>			3	6	56	R IM

Examples: Given: R1 = 12H, R2 = 03H, register 01H = 21H, register 02H = 03H, register 03H = 0AH:

AND	R1,R2	→	R1 = 02H, R2 = 03H
AND	R1,@R2	→	R1 = 02H, R2 = 03H
AND	01H,02H	→	Register 01H = 01H, register 02H = 03H
AND	01H,@02H	→	Register 01H = 00H, register 02H = 03H
AND	01H,#25H	→	Register 01H = 21H

In the first example, the destination working register R1 contains the value 12H and the source working register R2 contains 03H. The statement "AND R1,R2" logically ANDs the source operand 03H with the destination operand value 12H, leaving the value 02H in the register R1.

BAND — Bit AND

BAND dst,src.b

BAND dst.b,src

Operation: $dst(0) \leftarrow dst(0) \text{ AND } src(b)$
 or
 $dst(b) \leftarrow dst(b) \text{ AND } src(0)$

The specified bit of the source (or the destination) is logically ANDed with the zero bit (LSB) of the destination (or the source). The resultant bit is stored in the specified bit of the destination. No other bits of the destination are affected. The source is unaffected.

Flags:

- C:** Unaffected.
- Z:** Set if the result is "0"; cleared otherwise.
- S:** Cleared to "0".
- V:** Undefined.
- D:** Unaffected.
- H:** Unaffected.

Format:

			Bytes	Cycles	Opcode (Hex)	Addr Mode <u>dst</u> <u>src</u>
opc	dst b 0	src	3	6	67	r0 Rb
opc	src b 1	dst	3	6	67	Rb r0

NOTE: In the second byte of the 3-byte instruction formats, the destination (or the source) address is four bits, the bit address "b" is three bits, and the LSB address value is one bit in length.

Examples: Given: R1 = 07H and register 01H = 05H:

BAND R1,01H.1 → R1 = 06H, register 01H = 05H
 BAND 01H.1,R1 → Register 01H = 05H, R1 = 07H

In the first example, the source register 01H contains the value 05H (00000101B) and the destination working register R1 contains 07H (00000111B). The statement "BAND R1,01H.1" ANDs the bit 1 value of the source register ("0") with the bit 0 value of the register R1 (destination), leaving the value 06H (00000110B) in the register R1.

BCP — Bit Compare

BCP dst,src.b

Operation: dst(0) – src(b)

The specified bit of the source is compared to (subtracted from) bit zero (LSB) of the destination. The zero flag is set if the bits are the same; otherwise it is cleared. The contents of both operands are unaffected by the comparison.

Flags:

- C:** Unaffected.
- Z:** Set if the two bits are the same; cleared otherwise.
- S:** Cleared to "0".
- V:** Undefined.
- D:** Unaffected.
- H:** Unaffected.

Format:

			Bytes	Cycles	Opcode (Hex)	Addr Mode <u>dst</u> <u>src</u>
opc	dst b 0	src	3	6	17	r0 Rb

NOTE: In the second byte of the instruction format, the destination address is four bits, the bit address "0" is three bits, and the LSB address value is one bit in length.

Example: Given: R1 = 07H and register 01H = 01H:

BCP R1,01H.1 → R1 = 07H, register 01H = 01H

If the destination working register R1 contains the value 07H (00000111B) and the source register 01H contains the value 01H (00000001B), the statement "BCP R1,01H.1" compares bit one of the source register (01H) and bit zero of the destination register (R1). Because the bit values are not identical, the zero flag bit (Z) is cleared in the FLAGS register (0D5H).

BITC — Bit Complement

BITC dst.b

Operation: dst(b) ← NOT dst(b)

This instruction complements the specified bit within the destination without affecting any other bit in the destination.

Flags:

- C:** Unaffected.
- Z:** Set if the result is "0"; cleared otherwise.
- S:** Cleared to "0".
- V:** Undefined.
- D:** Unaffected.
- H:** Unaffected.

Format:

		Bytes	Cycles	Opcode (Hex)	Addr Mode <u>dst</u>
opc	dst b 0	2	4	57	rb

NOTE: In the second byte of the instruction format, the destination address is four bits, the bit address "b" is three bits, and the LSB address value is one bit in length.

Example: Given: R1 = 07H

BITC R1.1 → R1 = 05H

If the working register R1 contains the value 07H (00000111B), the statement "BITC R1.1" complements bit one of the destination and leaves the value 05H (00000101B) in the register R1. Because the result of the complement is not "0", the zero flag (Z) in the FLAGS register (0D5H) is cleared.

BITR — Bit Reset

BITR dst.b

Operation: dst(b) ← 0

The BITR instruction clears the specified bit within the destination without affecting any other bit in the destination.

Flags: No flags are affected.

Format:

		Bytes	Cycles	Opcode (Hex)	Addr Mode <u>dst</u>
opc	dst b 0	2	4	77	rb

NOTE: In the second byte of the instruction format, the destination address is four bits, the bit address "0" is three bits, and the LSB address value is one bit in length.

Example: Given: R1 = 07H:

BITR R1.1 → R1 = 05H

If the value of the working register R1 is 07H (00000111B), the statement "BITR R1.1" clears bit one of the destination register R1, leaving the value 05H (00000101B).

BITS — Bit Set

BITS dst.b

Operation: dst(b) ← 1

The BITS instruction sets the specified bit within the destination without affecting any other bit in the destination.

Flags: No flags are affected.

Format:

		Bytes	Cycles	Opcode (Hex)	Addr Mode <u>dst</u>
opc	dst b 1	2	4	77	rb

NOTE: In the second byte of the instruction format, the destination address is four bits, the bit address "b" is three bits, and the LSB address value is one bit in length.

Example: Given: R1 = 07H:

BITS R1.3 → R1 = 0FH

If the working register R1 contains the value 07H (00000111B), the statement "BITS R1.3" sets bit three of the destination register R1 to "1", leaving the value 0FH (00001111B).

BOR — Bit OR

BOR dst,src.b

BOR dst.b,src

Operation: $dst(0) \leftarrow dst(0) \text{ OR } src(b)$
 or
 $dst(b) \leftarrow dst(b) \text{ OR } src(0)$

The specified bit of the source (or the destination) is logically ORed with bit zero (LSB) of the destination (or the source). The resulting bit value is stored in the specified bit of the destination. No other bits of the destination are affected. The source is unaffected.

Flags: **C:** Unaffected.
Z: Set if the result is "0"; cleared otherwise.
S: Cleared to "0".
V: Undefined.
D: Unaffected.
H: Unaffected.

Format:

			Bytes	Cycles	Opcode (Hex)	Addr Mode <u>dst</u> <u>src</u>
opc	dst b 0	src	3	6	07	r0 Rb
opc	src b 1	dst	3	6	07	Rb r0

NOTE: In the second byte of the 3-byte instruction format, the destination (or the source) address is four bits, the bit address "b" is three bits, and the LSB address value is one bit.

Examples: Given: R1 = 07H and register 01H = 03H:

BOR R1, 01H.1 → R1 = 07H, register 01H = 03H
 BOR 01H.2, R1 → Register 01H = 07H, R1 = 07H

In the first example, the destination working register R1 contains the value 07H (00000111B) and the source register 01H the value 03H (00000011B). The statement "BOR R1,01H.1" logically ORs bit one of the register 01H (source) with bit zero of R1 (destination). This leaves the same value (07H) in the working register R1.

In the second example, the destination register 01H contains the value 03H (00000011B) and the source working register R1 the value 07H (00000111B). The statement "BOR 01H.2,R1" logically ORs bit two of the register 01H (destination) with bit zero of R1 (source). This leaves the value 07H in the register 01H.

BTJRF — Bit Test, Jump Relative on False

BTJRF dst,src.b

Operation: If src(b) is a "0", then $PC \leftarrow PC + dst$

The specified bit within the source operand is tested. If it is a "0", the relative address is added to the program counter and control passes to the statement whose address is currently in the program counter. Otherwise, the instruction following the BTJRF instruction is executed.

Flags: No flags are affected.

Format:

(note)			Bytes	Cycles	Opcode (Hex)	Addr Mode <u>dst</u> <u>src</u>
opc	src b 0	dst	3	10	37	RA rb

NOTE: In the second byte of the instruction format, the source address is four bits, the bit address "b" is three bits, and the LSB address value is one bit in length.

Example: Given: R1 = 07H:

BTJRF SKIP,R1.3 → PC jumps to SKIP location

If the working register R1 contains the value 07H (00000111B), the statement "BTJRF SKIP,R1.3" tests bit 3. Because it is "0", the relative address is added to the PC and the PC jumps to the memory location pointed to by the SKIP (Remember that the memory location must be within the allowed range of + 127 to - 128).

BTJRT — Bit Test, Jump Relative on True

BTJRT dst,src.b

Operation: If src(b) is a "1", then $PC \leftarrow PC + dst$

The specified bit within the source operand is tested. If it is a "1", the relative address is added to the program counter and control passes to the statement whose address is now in the PC. Otherwise, the instruction following the BTJRT instruction is executed.

Flags: No flags are affected.

Format:

(note)			Bytes	Cycles	Opcode (Hex)	Addr Mode dst src
opc	src b 1	dst	3	10	37	RA rb

NOTE: In the second byte of the instruction format, the source address is four bits, the bit address "b" is three bits, and the LSB address value is one bit in length.

Example: Given: R1 = 07H:

BTJRT SKIP,R1.1

If the working register R1 contains the value 07H (00000111B), the statement "BTJRT SKIP,R1.1" tests bit one in the source register (R1). Because it is a "1", the relative address is added to the PC and the PC jumps to the memory location pointed to by the SKIP.

Remember that the memory location addressed by the BTJRT instruction must be within the allowed range of + 127 to - 128.

BXOR — Bit XOR

BXOR dst,src.b

BXOR dst.b,src

Operation: $dst(0) \leftarrow dst(0) \text{ XOR } src(b)$
 or
 $dst(b) \leftarrow dst(b) \text{ XOR } src(0)$

The specified bit of the source (or the destination) is logically exclusive-ORed with bit zero (LSB) of the destination (or the source). The result bit is stored in the specified bit of the destination. No other bits of the destination are affected. The source is unaffected.

Flags:

- C:** Unaffected.
- Z:** Set if the result is "0"; cleared otherwise.
- S:** Cleared to "0".
- V:** Undefined.
- D:** Unaffected.
- H:** Unaffected.

Format:

			Bytes	Cycles	Opcode (Hex)	Addr Mode <u>dst</u> <u>src</u>
opc	dst b 0	src	3	6	27	r0 Rb
opc	src b 1	dst	3	6	27	Rb r0

NOTE: In the second byte of the 3-byte instruction format, the destination (or the source) address is four bits, the bit address "b" is three bits, and the LSB address value is one bit in length.

Examples: Given: R1 = 07H (00000111B) and register 01H = 03H (00000011B):

BXOR R1,01H.1 → R1 = 06H, register 01H = 03H
 BXOR 01H.2,R1 → Register 01H = 07H, R1 = 07H

In the first example, the destination working register R1 has the value 07H (00000111B) and the source register 01H has the value 03H (00000011B). The statement "BXOR R1,01H.1" exclusive-ORs bit one of the register 01H (the source) with bit zero of R1 (the destination). The result bit value is stored in bit zero of R1, changing its value from 07H to 06H. The value of the source register 01H is unaffected.

CALL — Call Procedure

CALL dst

Operation: SP ← SP-1
 @SP ← PCL
 SP ← SP-1
 @SP ← PCH
 PC ← dst

The contents of the program counter are pushed onto the top of the stack. The program counter value used is the address of the first instruction following the CALL instruction. The specified destination address is then loaded into the program counter and points to the first instruction of a procedure. At the end of the procedure the return instruction (RET) can be used to return to the original program flow. RET pops the top of the stack back into the program counter.

Flags: No flags are affected.

Format:

		Bytes	Cycles	Opcode (Hex)	Addr Mode <u>dst</u>
opc	dst	3	14	F6	DA
opc	dst	2	12	F4	IRR
opc	dst	2	14	D4	IA

Examples: Given: R0 = 35H, R1 = 21H, PC = 1A47H, and SP = 0002H:

CALL 3521H → SP = 0000H
 (Memory locations 0000H = 1AH, 0001H = 4AH,
 where, 4AH is the address that follows the instruction.)

CALL @RR0 → SP = 0000H (0000H = 1AH, 0001H = 49H)

CALL #40H → SP = 0000H (0000H = 1AH, 0001H = 49H)

In the first example, if the program counter value is 1A47H and the stack pointer contains the value 0002H, the statement "CALL 3521H" pushes the current PC value onto the top of the stack. The stack pointer now points to the memory location 0000H. The PC is then loaded with the value 3521H, the address of the first instruction in the program sequence to be executed.

If the contents of the program counter and the stack pointer are the same as in the first example, the statement "CALL @RR0" produces the same result except that the 49H is stored in stack location 0001H (because the two-byte instruction format was used). The PC is then loaded with the value 3521H, the address of the first instruction in the program sequence to be executed. Assuming that the contents of the program counter and the stack pointer are the same as in the first example, if the program address 0040H contains 35H and the program address 0041H contains 21H, the statement "CALL #40H" produces the same result as in the second example.

CCF — Complement Carry Flag

CCF

Operation: $C \leftarrow \text{NOT } C$

The carry flag (C) is complemented. If C = "1", the value of the carry flag is changed to logic zero. If C = "0", the value of the carry flag is changed to logic one.

Flags: **C:** Complemented.
No other flags are affected.

Format:

	Bytes	Cycles	Opcode (Hex)
opc	1	4	EF

Example: Given: The carry flag = "0":

CCF

If the carry flag = "0", the CCF instruction complements it in the FLAGS register (0D5H), changing its value from logic zero to logic one.

CLR — Clear

CLR dst

Operation: dst ← "0"

The destination location is cleared to "0".

Flags: No flags are affected.

Format:

		Bytes	Cycles	Opcode (Hex)	Addr Mode <u>dst</u>
opc	dst	2	4	B0	R
			4	B1	IR

Examples: Given: Register 00H = 4FH, register 01H = 02H, and register 02H = 5EH:

CLR 00H → Register 00H = 00H

CLR @01H → Register 01H = 02H, register 02H = 00H

In Register (R) addressing mode, the statement "CLR 00H" clears the destination register 00H value to 00H.

In the second example, the statement "CLR @01H" uses Indirect Register (IR) addressing mode to clear the 02H register value to 00H.

COM — Complement

COM dst

Operation: dst ← NOT dst

The contents of the destination location are complemented (one's complement). All "1s" are changed to "0s", and vice-versa.

Flags:

- C:** Unaffected.
- Z:** Set if the result is "0"; cleared otherwise.
- S:** Set if the result bit 7 is set; cleared otherwise.
- V:** Always reset to "0".
- D:** Unaffected.
- H:** Unaffected.

Format:

		Bytes	Cycles	Opcode (Hex)	Addr Mode <u>dst</u>
opc	dst	2	4	60	R
			4	61	IR

Examples: Given: R1 = 07H and register 07H = 0F1H:

```
COM   R1      →   R1 = 0F8H
COM   @R1     →   R1 = 07H, register 07H = 0EH
```

In the first example, the destination working register R1 contains the value 07H (00000111B). The statement "COM R1" complements all the bits in R1: all logic ones are changed to logic zeros, and logic zeros to logic ones, leaving the value 0F8H (11111000B).

In the second example, Indirect Register (IR) addressing mode is used to complement the value of the destination register 07H (11110001B), leaving the new value 0EH (00001110B).

CP — Compare

CP dst,src

Operation: dst–src

The source operand is compared to (subtracted from) the destination operand, and the appropriate flags are set accordingly. The contents of both operands are unaffected by the comparison.

Flags:

- C:** Set if a "borrow" occurred (src > dst); cleared otherwise.
- Z:** Set if the result is "0"; cleared otherwise.
- S:** Set if the result is negative; cleared otherwise.
- V:** Set if arithmetic overflow occurred; cleared otherwise.
- D:** Unaffected.
- H:** Unaffected.

Format:

			Bytes	Cycles	Opcode (Hex)	Addr dst	Mode src
opc	dst src		2	4	A2	r	r
				6	A3	r	lr
opc	src	dst	3	6	A4	R	R
				6	A5	R	IR
opc	dst	src	3	6	A6	R	IM

Examples: 1. Given: R1 = 02H and R2 = 03H:

CP R1,R2 → Set the C and S flags

The destination working register R1 contains the value 02H and the source register R2 contains the value 03H. The statement "CP R1,R2" subtracts the R2 value (source/subtrahend) from the R1 value (destination/minuend). Because a "borrow" occurs and the difference is negative, the C and the S flag values are "1".

2. Given: R1 = 05H and R2 = 0AH:

```
CP    R1,R2
JP    UGE,SKIP
INC   R1
SKIP  LD R3,R1
```

In this example, the destination working register R1 contains the value 05H which is less than the contents of the source working register R2 (0AH). The statement "CP R1,R2" generates C = "1" and the JP instruction does not jump to the SKIP location. After the statement "LD R3,R1" executes, the value 06H remains in the working register R3.

CPIJE — Compare, Increment, and Jump on Equal

CPIJE dst,src,RA

Operation: If $\text{dst} - \text{src} = "0"$, $\text{PC} \leftarrow \text{PC} + \text{RA}$
 $\text{lr} \leftarrow \text{lr} + 1$

The source operand is compared to (subtracted from) the destination operand. If the result is "0", the relative address is added to the program counter and control passes to the statement whose address is now in the program counter. Otherwise, the instruction immediately following the CPIJE instruction is executed. In either case, the source pointer is incremented by one before the next instruction is executed.

Flags: No flags are affected.

Format:

				Bytes	Cycles	Opcode (Hex)	Addr Mode <u>dst</u> <u>src</u>
opc	src	dst	RA	3	12	C2	r lr

Example: Given: R1 = 02H, R2 = 03H, and register 03H = 02H:

CPIJE R1,@R2,SKIP → R2 = 04H, PC jumps to SKIP location

In this example, the working register R1 contains the value 02H, the working register R2 the value 03H, and the register 03 contains 02H. The statement "CPIJE R1,@R2,SKIP" compares the @R2 value 02H (00000010B) to 02H (00000010B). Because the result of the comparison is *equal*, the relative address is added to the PC and the PC then jumps to the memory location pointed to by SKIP. The source register (R2) is incremented by one, leaving a value of 04H.

Remember that the memory location addressed by the CPIJE instruction must be within the allowed range of + 127 to - 128.

CPIJNE — Compare, Increment, and Jump on Non-Equal

CPIJNE dst,src,RA

Operation: If $\text{dst} - \text{src} \neq 0$, $\text{PC} \leftarrow \text{PC} + \text{RA}$
 $\text{lr} \leftarrow \text{lr} + 1$

The source operand is compared to (subtracted from) the destination operand. If the result is not "0", the relative address is added to the program counter and control passes to the statement whose address is now in the program counter. Otherwise the instruction following the CPIJNE instruction is executed. In either case the source pointer is incremented by one before the next instruction.

Flags: No flags are affected.

Format:

				Bytes	Cycles	Opcode (Hex)	Addr Mode <u>dst</u> <u>src</u>
opc	src	dst	RA	3	12	D2	r lr

Example: Given: R1 = 02H, R2 = 03H, and register 03H = 04H:

CPIJNE R1,@R2,SKIP → R2 = 04H, PC jumps to SKIP location

The working register R1 contains the value 02H, the working register R2 (the source pointer) the value 03H, and the general register 03 the value 04H. The statement "CPIJNE R1,@R2,SKIP" subtracts 04H (00000100B) from 02H (00000010B). Because the result of the comparison is *non-equal*, the relative address is added to the PC and the PC then jumps to the memory location pointed to by SKIP. The source pointer register (R2) is also incremented by one, leaving a value of 04H.

Remember that the memory location addressed by the CPIJNE instruction must be within the allowed range of +127 to -128.

DA — Decimal Adjust

DA dst

Operation: dst ← DA dst

The destination operand is adjusted to form two 4-bit BCD digits following an addition or subtraction operation. For addition (ADD, ADC) or subtraction (SUB, SBC), the following table indicates the operation performed (The operation is undefined if the destination operand is not the result of a valid addition or subtraction of BCD digits):

Instruction	Carry Before DA	Bits 4–7 Value (Hex)	H Flag Before DA	Bits 0–3 Value (Hex)	Number Added to Byte	Carry After DA
	0	0–9	0	0–9	00	0
	0	0–8	0	A–F	06	0
	0	0–9	1	0–3	06	0
ADD	0	A–F	0	0–9	60	1
ADC	0	9–F	0	A–F	66	1
	0	A–F	1	0–3	66	1
	1	0–2	0	0–9	60	1
	1	0–2	0	A–F	66	1
	1	0–3	1	0–3	66	1
	0	0–9	0	0–9	00 = – 00	0
SUB	0	0–8	1	6–F	FA = – 06	0
SBC	1	7–F	0	0–9	A0 = – 60	1
	1	6–F	1	6–F	9A = – 66	1

Flags:

- C:** Set if there was a carry from the most significant bit; cleared otherwise (see table).
- Z:** Set if result is "0"; cleared otherwise.
- S:** Set if result bit 7 is set; cleared otherwise.
- V:** Undefined.
- D:** Unaffected.
- H:** Unaffected.

Format:

		Bytes	Cycles	Opcode (Hex)	Addr Mode <u>dst</u>
opc	dst	2	4	40	R
			4	41	IR



DA — Decimal Adjust

DA (Continued)

Example: Given: The working register R0 contains the value 15 (BCD), the working register R1 contains 27 (BCD), and the address 27H contains 46 (BCD):

```
ADD    R1,R0    ;    C ← "0", H ← "0", Bits 4–7 = 3, bits 0–3 = C, R1 ← 3CH
DA     R1       ;    R1 ← 3CH + 06
```

If an addition is performed using the BCD values 15 and 27, the result should be 42. The sum is incorrect, however, when the binary representations are added in the destination location using the standard binary arithmetic:

```
  0 0 0 1  0 1 0 1    15
+ 0 0 1 0  0 1 1 1    27
-----
  0 0 1 1  1 1 0 0    =  3CH
```

The DA instruction adjusts this result so that the correct BCD representation is obtained:

```
  0 0 1 1  1 1 0 0
+ 0 0 0 0  0 1 1 0
-----
  0 1 0 0  0 0 1 0    =  42
```

Assuming the same values given above, the statements

```
SUB    27H,R0    ;    C ← "0", H ← "0", Bits 4–7 = 3, bits 0–3 = 1
DA     @R1       ;    @R1 ← 31–0
```

leave the value 31 (BCD) in the address 27H (@R1).

DEC — Decrement

DEC dst

Operation: dst ← dst-1

The contents of the destination operand are decremented by one.

Flags:

- C:** Unaffected.
- Z:** Set if the result is "0"; cleared otherwise.
- S:** Set if result is negative; cleared otherwise.
- V:** Set if arithmetic overflow occurred; cleared otherwise.
- D:** Unaffected.
- H:** Unaffected.

Format:

		Bytes	Cycles	Opcode (Hex)	Addr Mode <u>dst</u>
opc	dst	2	4	00	R
			4	01	IR

Examples: Given: R1 = 03H and register 03H = 10H:

```
DEC   R1      →   R1 = 02H
DEC   @R1     →   Register 03H = 0FH
```

In the first example, if the working register R1 contains the value 03H, the statement "DEC R1" decrements the hexadecimal value by one, leaving the value 02H. In the second example, the statement "DEC @R1" decrements the value 10H contained in the destination register 03H by one, leaving the value 0FH.

DECW — Decrement Word

DECW dst

Operation: dst ← dst – 1

The contents of the destination location (which must be an even address) and the operand following that location are treated as a single 16-bit value that is decremented by one.

Flags:

- C:** Unaffected.
- Z:** Set if the result is "0"; cleared otherwise.
- S:** Set if the result is negative; cleared otherwise.
- V:** Set if arithmetic overflow occurred; cleared otherwise.
- D:** Unaffected.
- H:** Unaffected.

Format:

		Bytes	Cycles	Opcode (Hex)	Addr Mode <u>dst</u>
opc	dst	2	8	80	RR
			8	81	IR

Examples: Given: R0 = 12H, R1 = 34H, R2 = 30H, register 30H = 0FH, and register 31H = 21H:

```
DECW   RR0      →      R0 = 12H, R1 = 33H
DECW   @R2      →      Register 30H = 0FH, register 31H = 20H
```

In the first example, the destination register R0 contains the value 12H and the register R1 the value 34H. The statement "DECW RR0" addresses R0 and the following operand R1 as a 16-bit word and decrements the value of R1 by one, leaving the value 33H.

NOTE: A system malfunction may occur if you use a Zero flag (FLAGS.6) result together with a DECW instruction.

To avoid this problem, it is recommended to use DECW as shown in the following example.

```
LOOP   DECW     RR0
LD     R2,R1
OR     R2,R0
JR     NZ,LOOP
```

DI — Disable Interrupts

DI

Operation: SYM(0) ← 0

Bit zero of the system mode control register, SYM.0, is cleared to "0", globally disabling all interrupt processing. Interrupt requests will continue to set their respective interrupt pending bits, but the CPU will not service them while interrupt processing is disabled.

Flags: No flags are affected.

Format:

	Bytes	Cycles	Opcode (Hex)
opc	1	4	8F

Example: Given: SYM = 01H:

DI

If the value of the SYM register is 01H, the statement "DI" leaves the new value 00H in the register and clears SYM.0 to "0", disabling interrupt processing.

DIV — Divide (Unsigned)

DIV dst,src

Operation: dst ÷ src
 dst (UPPER) ← REMAINDER
 dst (LOWER) ← QUOTIENT

The destination operand (16 bits) is divided by the source operand (8 bits). The quotient (8 bits) is stored in the lower half of the destination. The remainder (8 bits) is stored in the upper half of the destination. When the quotient is ≥ 28 , the numbers stored in the upper and lower halves of the destination for quotient and remainder are incorrect. Both operands are treated as unsigned integers.

Flags:

- C:** Set if the V flag is set and the quotient is between 28 and 29 –1; cleared otherwise.
- Z:** Set if the divisor or the quotient = "0"; cleared otherwise.
- S:** Set if MSB of the quotient = "1"; cleared otherwise.
- V:** Set if the quotient is ≥ 28 or if the divisor = "0"; cleared otherwise.
- D:** Unaffected.
- H:** Unaffected.

Format:

			Bytes	Cycles	Opcode (Hex)	Addr Mode <u>dst</u> <u>src</u>
opc	src	dst	3	26/10 *	94	RR R
				26/10 *	95	RR IR
				26/10 *	96	RR IM

* Execution takes 10 cycles if the divide-by-zero is attempted, otherwise, it takes 26 cycles.

Examples: Given: R0 = 10H, R1 = 03H, R2 = 40H, register 40H = 80H:

DIVRR0,R2 → R0 = 03H, R1 = 40H
 DIVRR0,@R2 → R0 = 03H, R1 = 20H
 DIVRR0,#20H → R0 = 03H, R1 = 80H

In the first example, the destination working register pair RR0 contains the values 10H (R0) and 03H (R1), and the register R2 contains the value 40H. The statement "DIV RR0,R2" divides the 16-bit RR0 value by the 8-bit value of the R2 (source) register. After the DIV instruction, R0 contains the value 03H and R1 contains 40H. The 8-bit remainder is stored in the upper half of the destination register RR0 (R0) and the quotient in the lower half (R1).

DJNZ — Decrement and Jump if Non-Zero

DJNZ r,dst

Operation: $r \leftarrow r - 1$
 If $r \neq 0$, $PC \leftarrow PC + dst$

The working register being used as a counter is decremented. If the contents of the register are not logic zero after decrementing, the relative address is added to the program counter and control passes to the statement whose address is now in the PC. The range of the relative address is + 127 to - 128, and the original value of the PC is taken to be the address of the instruction byte following the DJNZ statement.

NOTE: In case of using DJNZ instruction, the working register being used as a counter should be set at the one of location 0C0H to 0CFH with SRP, SRP0 or SRP1 instruction.

Flags: No flags are affected.

Format:

		Bytes	Cycles	Opcode (Hex)	Addr Mode <u>dst</u>		
r		opc	dst	2	8 (jump taken)	rA	RA
					8 (no jump)	r = 0 to F	

Example: Given: R1 = 02H and LOOP is the label of a relative address:

```
SRP        #0C0H
DJNZ      R1,LOOP
```

DJNZ is typically used to control a "loop" of instructions. In many cases, a label is used as the destination operand instead of a numeric relative address value. In the example, the working register R1 contains the value 02H, and LOOP is the label for a relative address.

The statement "DJNZ R1, LOOP" decrements the register R1 by one, leaving the value 01H. Because the contents of R1 after the decrement are non-zero, the jump is taken to the relative address specified by the LOOP label.

EI — Enable Interrupts

EI

Operation: SYM (0) ← 1

The EI instruction sets bit zero of the system mode register, SYM.0 to "1". This allows interrupts to be serviced as they occur (assuming they have the highest priority). If an interrupt's pending bit was set while interrupt processing was disabled (by executing a DI instruction), it will be serviced when the EI instruction is executed.

Flags: No flags are affected.

Format:

	Bytes	Cycles	Opcode (Hex)
opc	1	4	9F

Example: Given: SYM = 00H:

EI

If the SYM register contains the value 00H, that is, if interrupts are currently disabled, the statement "EI" sets the SYM register to 01H, enabling all interrupts. (SYM.0 is the enable bit for global interrupt processing.)

ENTER — Enter

ENTER

Operation: $SP \leftarrow SP - 2$
 $@SP \leftarrow IP$
 $IP \leftarrow PC$
 $PC \leftarrow @IP$
 $IP \leftarrow IP + 2$

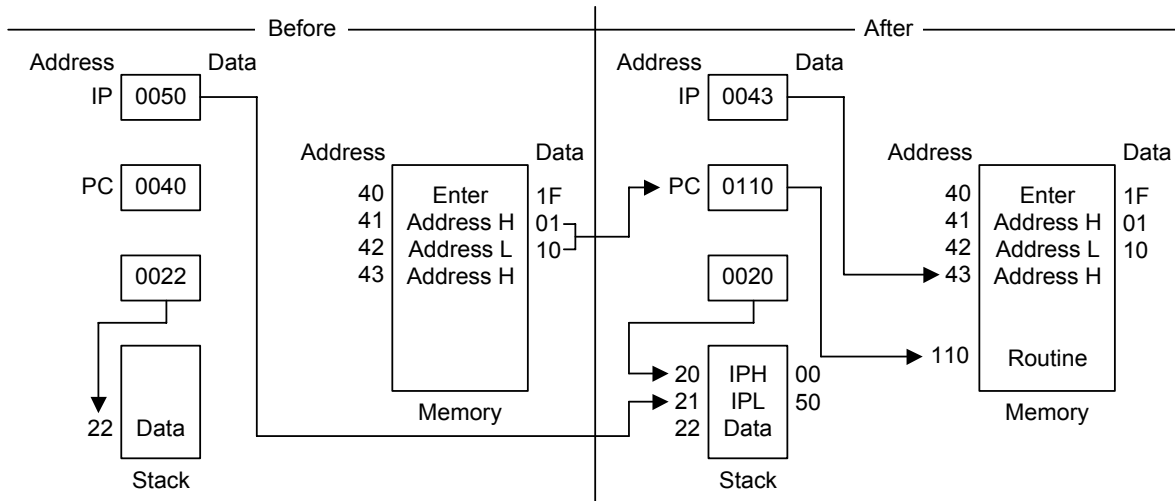
This instruction is useful when implementing threaded-code languages. The contents of the instruction pointer are pushed to the stack. The program counter (PC) value is then written to the instruction pointer. The program memory word that is pointed to by the instruction pointer is loaded into the PC, and the instruction pointer is incremented by two.

Flags: No flags are affected.

Format:

	Bytes	Cycles	Opcode (Hex)
opc	1	14	1F

Example: The diagram below shows an example of how to use an ENTER statement.



EXIT — Exit

EXIT

Operation:

$$\begin{aligned} \text{IP} &\leftarrow @\text{SP} \\ \text{SP} &\leftarrow \text{SP} + 2 \\ \text{PC} &\leftarrow @\text{IP} \\ \text{IP} &\leftarrow \text{IP} + 2 \end{aligned}$$

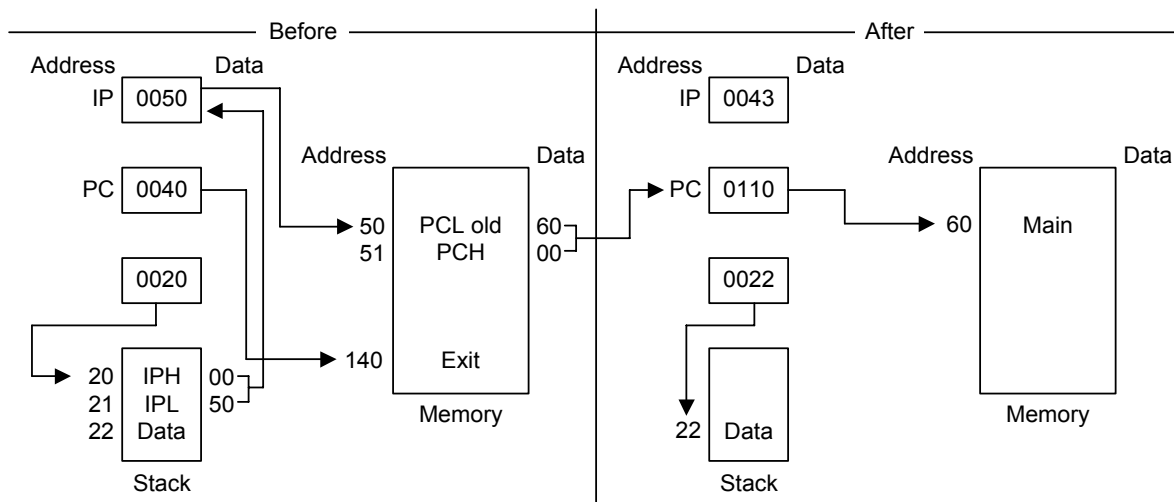
This instruction is useful when implementing threaded-code languages. The stack value is popped and loaded into the instruction pointer. The program memory word that is pointed to by the instruction pointer is then loaded into the program counter, and the instruction pointer is incremented by two.

Flags: No flags are affected.

Format:

	Bytes	Cycles	Opcode (Hex)
opc	1	16	2F

Example: The diagram below shows an example of how to use an EXIT statement.



IDLE — Idle Operation

IDLE

Operation: (See description)

The IDLE instruction stops the CPU clock while allowing the system clock oscillation to continue. Idle mode can be released by an interrupt request (IRQ) or an external reset operation.

Flags: No flags are affected.

Format:

	Bytes	Cycles	Opcode (Hex)	Addr <u>dst</u>	Mode <u>src</u>
opc	1	4	6F	-	-

Example: The instruction **IDLE** stops the CPU clock but it does not stop the system clock.

INC — Increment

INC dst

Operation: dst ← dst + 1

The contents of the destination operand are incremented by one.

Flags:

- C:** Unaffected.
- Z:** Set if the result is "0"; cleared otherwise.
- S:** Set if the result is negative; cleared otherwise.
- V:** Set if arithmetic overflow occurred; cleared otherwise.
- D:** Unaffected.
- H:** Unaffected.

Format:

	Bytes	Cycles	Opcode (Hex)	Addr Mode
<div style="border: 1px solid black; padding: 2px; display: inline-block;">dst opc</div>	1	4	rE r = 0 to F	<u>dst</u> r
<div style="display: inline-block; border: 1px solid black; padding: 2px;">opc</div> <div style="display: inline-block; border: 1px solid black; padding: 2px; margin-left: 10px;">dst</div>	2	4 4	20 21	R IR

Examples: Given: R0 = 1BH, register 00H = 0CH, and register 1BH = 0FH:

INCR0 → R0 = 1CH
 INC00H → Register 00H = 0DH
 INC@R0 → R0 = 1BH, register 01H = 10H

In the first example, if the destination working register R0 contains the value 1BH, the statement "INC R0" leaves the value 1CH in that same register.

The second example shows the effect an INC instruction has on the register at the location 00H, assuming that it contains the value 0CH.

In the third example, INC is used in Indirect Register (IR) addressing mode to increment the value of the register 1BH from 0FH to 10H.

INCW — Increment Word

INCW dst

Operation: dst ← dst + 1

The contents of the destination (which must be an even address) and the byte following that location are treated as a single 16-bit value that is incremented by one.

Flags:

- C:** Unaffected.
- Z:** Set if the result is "0"; cleared otherwise.
- S:** Set if the result is negative; cleared otherwise.
- V:** Set if arithmetic overflow occurred; cleared otherwise.
- D:** Unaffected.
- H:** Unaffected.

Format:

		Bytes	Cycles	Opcode (Hex)	Addr Mode <u>dst</u>
opc	dst	2	8	A0	RR
			8	A1	IR

Examples: Given: R0 = 1AH, R1 = 02H, register 02H = 0FH, and register 03H = 0FFH:

```
INCW    RR0        →        R0 = 1AH, R1 = 03H
INCW    @R1       →        Register 02H = 10H, register 03H = 00H
```

In the first example, the working register pair RR0 contains the value 1AH in the register R0 and 02H in the register R1. The statement "INCW RR0" increments the 16-bit destination by one, leaving the value 03H in the register R1. In the second example, the statement "INCW @R1" uses Indirect Register (IR) addressing mode to increment the contents of the general register 03H from 0FFH to 00H and the register 02H from 0FH to 10H.

NOTE: A system malfunction may occur if you use a Zero (Z) flag (FLAGS.6) result together with an INCW instruction. To avoid this problem, it is recommended to use the INCW instruction as shown in the following example:

```
LOOP:    INCW        RR0
          LD          R2,R1
          OR          R2,R0
          JR          NZ,LOOP
```


IRET — Interrupt Return

IRET	IRET (Normal)	RET (Fast)
Operation:	$\text{FLAGS} \leftarrow @\text{SP}$ $\text{SP} \leftarrow \text{SP} + 1$ $\text{PC} \leftarrow @\text{SP}$ $\text{SP} \leftarrow \text{SP} + 2$ $\text{SYM}(0) \leftarrow 1$	$\text{PC} \leftrightarrow \text{IP}$ $\text{FLAGS} \leftarrow \text{FLAGS}'$ $\text{FIS} \leftarrow 0$

This instruction is used at the end of an interrupt service routine. It restores the flag register and the program counter. It also re-enables global interrupts. A "normal IRET" is executed only if the fast interrupt status bit (FIS, bit one of the FLAGS register, 0D5H) is cleared (= "0"). If a fast interrupt occurred, IRET clears the FIS bit that was set at the beginning of the service routine.

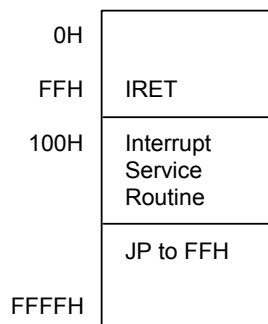
Flags: All flags are restored to their original settings (that is, the settings before the interrupt occurred).

Format:

IRET (Normal)	Bytes	Cycles	Opcode (Hex)
opc	1	12	BF
IRET (Fast)	Bytes	Cycles	Opcode (Hex)
opc	1	6	BF

Example: In the figure below, the instruction pointer is initially loaded with 100H in the main program before interrupt are enabled. When an interrupt occurs, the program counter and the instruction pointer are swapped. This causes the PC to jump to the address 100H and the IP to keep the return address. The last instruction in the service routine is normally a jump to IRET at the address FFH.

This loads the instruction pointer with 100H "again" and causes the program counter to jump back to the main program. Now, the next interrupt can occur and the IP is still correct at 100H.



NOTE: In the fast interrupt example above, if the last instruction is not a jump to IRET, you must pay attention to the order of the last two instructions. The IRET cannot be immediately preceded by an instruction which clears the interrupt status (as with a reset of the IPR register).

JP — Jump

JP cc,dst (Conditional)

JP dst (Unconditional)

Operation: If cc is true, PC ← dst

The conditional JUMP instruction transfers program control to the destination address if the condition specified by the condition code (cc) is true, otherwise, the instruction following the JP instruction is executed. The unconditional JP simply replaces the contents of the PC with the contents of the specified register pair. Control then passes to the statement addressed by the PC.

Flags: No flags are affected.

Format: (1)

		Bytes	Cycles	Opcode (Hex)	Addr Mode <u>dst</u>
(2)					
cc opc	dst	3	8	ccD	DA
cc = 0 to F					
opc	dst	2	8	30	IRR

NOTES:

1. The 3-byte format is used for a conditional jump and the 2-byte format for an unconditional jump.
2. In the first byte of the 3-byte instruction format (conditional jump), the condition code and the OPCODE are both four bits.

Examples: Given: The carry flag (C) = "1", register 00 = 01H, and register 01 = 20H:Secs

JP C,LABEL_W → LABEL_W = 1000H, PC = 1000H
 JP @00H → PC = 0120H

The first example shows a conditional JP. Assuming that the carry flag is set to "1", the statement "JP C,LABEL_W" replaces the contents of the PC with the value 1000H and transfers control to that location. Had the carry flag not been set, control would then have passed to the statement immediately following the JP instruction.

The second example shows an unconditional JP. The statement "JP @00" replaces the contents of the PC with the contents of the register pair 00H and 01H, leaving the value 0120H.

JR — Jump Relative

JR cc,dst

Operation: If cc is true, $PC \leftarrow PC + dst$

If the condition specified by the condition code (cc) is true, the relative address is added to the program counter and control passes to the statement whose address is now in the program counter, otherwise, the instruction following the JR instruction is executed. (See the list of condition codes at the beginning of this chapter).

The range of the relative address is +127, -128, and the original value of the program counter is taken to be the address of the first instruction byte following the JR statement.

Flags: No flags are affected.

Format:

(note)			Bytes	Cycles	Opcode (Hex)	Addr Mode dst
cc	opc	dst	2	6	ccB	RA
cc = 0 to F						

NOTE: In the first byte of the two-byte instruction format, the condition code and the opcode are each four bits in length.

Example: Given: The carry flag = "1" and LABEL_X = 1FF7H:

JR C,LABEL_X → PC = 1FF7H

If the carry flag is set (that is, if the condition code is "true"), the statement "JR C,LABEL_X" will pass control to the statement whose address is currently in the program counter. Otherwise, the program instruction following the JR will be executed.

LD — Load

LD dst,src

Operation: dst ← src

The contents of the source are loaded into the destination. The source's contents are unaffected.

Flags: No flags are affected.

Format:

			Bytes	Cycles	Opcode (Hex)	Addr <u>dst</u>	Mode <u>src</u>
dst opc	opc	src	2	4	rC	r	IM
				4	r8	r	R
src opc	opc	dst	2	4	r9	R	r
opc	opc	dst src	2	4	C7	r	lr
				4	D7	lr	r
opc	opc	src	3	6	E4	R	R
				6	E5	R	IR
opc	opc	dst	3	6	E6	R	IM
				6	D6	IR	IM
opc	opc	src	3	6	F5	IR	R
opc	opc	dst src	3	6	87	r	x [r]
opc	opc	src dst	3	6	97	x [r]	r

LD — Load

LD (Continued)

Examples: Given: R0 = 01H, R1 = 0AH, register 00H = 01H, register 01H = 20H, register 02H = 02H, LOOP = 30H, and register 3AH = 0FFH:

LD R0,#10H	→	R0 = 10H
LD R0,01H	→	R0 = 20H, register 01H = 20H
LD 01H,R0	→	Register 01H = 01H, R0 = 01H
LD R1,@R0	→	R1 = 20H, R0 = 01H
LD @R0,R1	→	R0 = 01H, R1 = 0AH, register 01H = 0AH
LD 00H,01H	→	Register 00H = 20H, register 01H = 20H
LD 02H,@00H	→	Register 02H = 20H, register 00H = 01H
LD 00H,#0AH	→	Register 00H = 0AH
LD @00H,#10H	→	Register 00H = 01H, register 01H = 10H
LD @00H,02H	→	Register 00H = 01H, register 01H = 02, register 02H = 02H
LD R0,#LOOP[R1]	→	R0 = 0FFH, R1 = 0AH
LD #LOOP[R0],R1	→	Register 31H = 0AH, R0 = 01H, R1 = 0AH

LDB — Load Bit

LDB dst,src.b

LDB dst.b,src

Operation: dst(0) ← src(b)
or
dst(b) ← src(0)

The specified bit of the source is loaded into bit zero (LSB) of the destination, or bit zero of the source is loaded into the specified bit of the destination. No other bits of the destination are affected. The source is unaffected.

Flags: No flags are affected.

Format:

			Bytes	Cycles	Opcode (Hex)	Addr Mode <u>dst</u> <u>src</u>
opc	dst b 0	src	3	6	47	r0 Rb
opc	src b 1	dst	3	6	47	Rb r0

NOTE: In the second byte of the instruction format, the destination (or the source) address is four bits, the bit address "b" is three bits, and the LSB address value is one bit in length.

Examples: Given: R0 = 06H and general register 00H = 05H:

LDB R0,00H.2 → R0 = 07H, register 00H = 05H
LDB 00H.0,R0 → R0 = 06H, register 00H = 04H

In the first example, the destination working register R0 contains the value 06H and the source general register 00H the value 05H. The statement "LD R0,00H.2" loads the bit two value of the 00H register into bit zero of the R0 register, leaving the value 07H in the register R0.

In the second example, 00H is the destination register. The statement "LD 00H.0,R0" loads bit zero of the register R0 to the specified bit (bit zero) of the destination register, leaving 04H in the general register 00H.

LDC/LDE — Load Memory

LDC dst,src

LDE dst,src

Operation: dst ← src

This instruction loads a byte from program or data memory into a working register or vice-versa. The source values are unaffected. LDC refers to program memory and LDE to data memory. The assembler makes "lrr" or "rrr" values an even number for program memory and an odd number for data memory.

Flags: No flags are affected.

Format:

		Bytes	Cycles	Opcode (Hex)	Addr <u>dst</u>	Mode <u>src</u>
1.	opc dst src	2	10	C3	r	lrr
2.	opc src dst	2	10	D3	lrr	r
3.	opc dst src XS	3	12	E7	r	XS [rr]
4.	opc src dst XS	3	12	F7	XS [rr]	r
5.	opc dst src XL _L XL _H	4	14	A7	r	XL [rr]
6.	opc src dst XL _L XL _H	4	14	B7	XL [rr]	r
7.	opc dst 0000 DA _L DA _H	4	14	A7	r	DA
8.	opc src 0000 DA _L DA _H	4	14	B7	DA	r
9.	opc dst 0001 DA _L DA _H	4	14	A7	r	DA
10.	opc src 0001 DA _L DA _H	4	14	B7	DA	r

NOTES:

1. The source (src) or the working register pair [rr] for formats 5 and 6 cannot use the register pair 0–1.
2. For the formats 3 and 4, the destination "XS [rr]" and the source address "XS [rr]" are both one byte.
3. For the formats 5 and 6, the destination "XL [rr]" and the source address "XL [rr]" are both two bytes.
4. The DA and the r source values for the formats 7 and 8 are used to address program memory. The second set of values, used in the formats 9 and 10, are used to address data memory.
5. LDE instruction can be used to read/write the data of 64-Kbyte data memory.

LDC/LDE — Load Memory

LDC/LDE (Continued)

Examples: Given: R0 = 11H, R1 = 34H, R2 = 01H, R3 = 04H; Program memory locations
0103H = 4FH, 0104H = 1A, 0105H = 6DH, and 1104H = 88H.
External data memory locations
0103H = 5FH, 0104H = 2AH, 0105H = 7DH, and 1104H = 98H:

LDC	R0,@RR2	; R0 ← contents of program memory location 0104H; ; R0 = 1AH, R2 = 01H, R3 = 04H
LDE	R0,@RR2	; R0 ← contents of external data memory location 0104H; ; R0 = 2AH, R2 = 01H, R3 = 04H
LDC	@RR2,R0	; 11H (contents of R0) is loaded into program memory location 0104H (RR2); R0, R2, R3 → no change
LDE	@RR2,R0	; 11H (contents of R0) is loaded into external data memory location 0104H (RR2); R0, R2, R3 → no change
LDC	R0,#01H[RR2]	; R0 ← contents of program memory location 0105H (01H + RR2); R0 = 6DH, R2 = 01H, R3 = 04H
LDE	R0,#01H[RR2]	; R0 ← contents of external data memory location 0105H (01H + RR2); R0 = 7DH, R2 = 01H, R3 = 04H
LDC	#01H[RR2],R0	; 11H (contents of R0) is loaded into program memory location 0105H (01H + 0104H)
LDE	#01H[RR2],R0	; 11H (contents of R0) is loaded into external data memory location 0105H (01H + 0104H)
LDC	R0,#1000H[RR2]	; R0 ← contents of program memory location 1104H (1000H + 0104H); R0 = 88H, R2 = 01H, R3 = 04H
LDE	R0,#1000H[RR2]	; R0 ← contents of external data memory location 1104H (1000H + 0104H); R0 = 98H, R2 = 01H, R3 = 04H
LDC	R0,1104H	; R0 ← contents of program memory location 1104H ; R0 = 88H
LDE	R0,1104H	; R0 ← contents of external data memory location 1104H; ; R0 = 98H
LDC	1105H,R0	; 11H (contents of R0) is loaded into program memory location 1105H; (1105H) ← 11H
LDE	1105H,R0	; 11H (contents of R0) is loaded into external data memory location 1105H; (1105H) ← 11H

NOTE: The LDC and the LDE instructions are not supported by masked ROM type devices.

LDCD/LDED — Load Memory and Decrement

LDCD dst,src

LDED dst,src

Operation: dst ← src
rr ← rr – 1

These instructions are used for user stacks or block transfers of data from program or data memory to the register file. The address of the memory location is specified by a working register pair. The contents of the source location are loaded into the destination location. The memory address is then decremented. The contents of the source are unaffected.

LDCD refers to program memory and LDED refers to external data memory. The assembler makes "lrr" an even number for program memory and an odd number for data memory.

Flags: No flags are affected.

Format:

		Bytes	Cycles	Opcode (Hex)	Addr Mode <u>dst</u> <u>src</u>
opc	dst src	2	10	E2	r lrr

Examples: Given: R6 = 10H, R7 = 33H, R8 = 12H, program memory location 1033H = 0CDH, and external data memory location 1033H = 0DDH:

```
LDCD    R8,@RR6    ; 0CDH (contents of program memory location 1033H) is
                    ; loaded
                    ; into R8 and RR6 is decremented by one;
                    ; R8 = 0CDH, R6 = 10H, R7 = 32H (RR6 ← RR6 – 1)
LDED    R8,@RR6    ; 0DDH (contents of data memory location 1033H) is
                    ; loaded
                    ; into R8 and RR6 is decremented by one
                    ; (RR6 ← RR6 – 1);
                    ; R8 = 0DDH, R6 = 10H, R7 = 32H
```

NOTE: LDED instruction can be used to read/write the data of 64-Kbyte data memory.

LDCI/LDEI — Load Memory and Increment

LDCI dst,src

LDEI dst,src

Operation: dst ← src
 rr ← rr + 1

These instructions are used for user stacks or block transfers of data from program or data memory to the register file. The address of the memory location is specified by a working register pair. The contents of the source location are loaded into the destination location. The memory address is then incremented automatically. The contents of the source are unaffected. LDCI refers to program memory and LDEI refers to external data memory. The assembler makes "lrr" an even number for program memory and an odd number for data memory.

Flags: No flags are affected.

Format:

		Bytes	Cycles	Opcode (Hex)	Addr Mode <u>dst</u> <u>src</u>
opc	dst src	2	10	E3	r lrr

Examples: Given: R6 = 10H, R7 = 33H, R8 = 12H, program memory locations 1033H = 0CDH and 1034H = 0C5H; external data memory locations 1033H = 0DDH and 1034H = 0D5H:

```
LDCI      R8,@RR6            ; 0CDH (contents of program memory location 1033H) is
                                  loaded
                                  ; into R8 and RR6 is incremented by one
                                  (RR6 ← RR6 + 1);
                                  ; R8 = 0CDH, R6 = 10H, R7 = 34H
LDEI      R8,@RR6            ; 0DDH (contents of data memory location 1033H) is
                                  loaded
                                  ; into R8 and RR6 is incremented by one
                                  (RR6 ← RR6 + 1);
                                  ; R8 = 0DDH, R6 = 10H, R7 = 34H
```

NOTE: LDEI instruction can be used to read/write the data of 64-Kbyte data memory.

LDCPD/LDEPD — Load Memory with Pre-Decrement

LDCPD dst,src

LDEPD dst,src

Operation: $rr \leftarrow rr - 1$
 $dst \leftarrow src$

These instructions are used for block transfers of data from program or data memory to the register file. The address of the memory location is specified by a working register pair and is first decremented. The contents of the source location are then loaded into the destination location. The contents of the source are unaffected.

LDCPD refers to program memory and LDEPD refers to external data memory. The assembler makes "lrr" an even number for program memory and an odd number for external data memory.

Flags: No flags are affected.

Format:

		Bytes	Cycles	Opcode (Hex)	Addr Mode <u>dst</u> <u>src</u>
opc	src dst	2	14	F2	lrr r

Examples: Given: R0 = 77H, R6 = 30H, and R7 = 00H:

```
LDCPD  @RR6,R0      ; (RR6 ← RR6 – 1)
          ; 77H (the contents of R0) is loaded into program memory
          ; location 2FFFH (3000H – 1H);
          ; R0 = 77H, R6 = 2FH, R7 = 0FFH
LDEPD  @RR6,R0      ; (RR6 ← RR6 – 1)
          ; 77H (the contents of R0) is loaded into external data
          ; memory
          ; location 2FFFH (3000H – 1H);
```

NOTE: LDEPD instruction can be used to read/write the data of 64-Kbyte data memory.

LDCPI/LDEPI — Load Memory with Pre-Increment

LDCPI dst,src

LDEPI dst,src

Operation: $rr \leftarrow rr + 1$
 $dst \leftarrow src$

These instructions are used for block transfers of data from program or data memory to the register file. The address of the memory location is specified by a working register pair and is first incremented. The contents of the source location are loaded into the destination location. The contents of the source are unaffected.

LDCPI refers to program memory and LDEPI refers to external data memory. The assembler makes "lrr" an even number for program memory and an odd number for data memory.

Flags: No flags are affected.

Format:

		Bytes	Cycles	Opcode (Hex)	Addr Mode <u>dst</u> <u>src</u>
opc	src dst	2	14	F3	lrr r

Examples: Given: R0 = 7FH, R6 = 21H, and R7 = 0FFH:

```
LDCPI    @RR6,R0            ; (RR6 ← bRR6 + 1)
                             ; 7FH (the contents of R0) is loaded into program memory
                             ; location 2200H (21FFH + 1H);
                             ; R0 = 7FH, R6 = 22H, R7 = 00H
LDEPI    @RR6,R0            ; (RR6 ← bRR6 + 1)
                             ; 7FH (the contents of R0) is loaded into external data
                             ; memory
                             ; location 2200H (21FFH + 1H);
                             ; R0 = 7FH, R6 = 22H, R7 = 00H
```

NOTE: LDEPI instruction can be used to read/write the data of 64-Kbyte data memory.

LDW — Load Word

LDW dst,src

Operation: dst ← src

The contents of the source (a word) are loaded into the destination. The contents of the source are unaffected.

Flags: No flags are affected.

Format:

			Bytes	Cycles	Opcode (Hex)	Addr Mode <u>dst</u> <u>src</u>
opc	src	dst	3	8	C4	RR RR
				8	C5	RR IR
opc	dst	src	4	8	C6	RR IML

Examples: Given: R4 = 06H, R5 = 1CH, R6 = 05H, R7 = 02H, register 00H = 1AH, register 01H = 02H, register 02H = 03H, and register 03H = 0FH

```
LDW  RR6,RR4  →  R6 = 06H, R7 = 1CH, R4 = 06H, R5 = 1CH
LDW  00H,02H  →  Register 00H = 03H, register 01H = 0FH,
                  register 02H = 03H, register 03H = 0FH
LDW  RR2,@R7  →  R2 = 03H, R3 = 0FH,
LDW  04H,@01H →  Register 04H = 03H, register 05H = 0FH
LDW  RR6,#1234H → R6 = 12H, R7 = 34H
LDW  02H,#0FEDH → Register 02H = 0FH, register 03H = 0EDH
```

In the second example, please note that the statement "LDW 00H,02H" loads the contents of the source word 02H and 03H into the destination word 00H and 01H. This leaves the value 03H in the general register 00H and the value 0FH in the register 01H.

Other examples show how to use the LDW instruction with various addressing modes and formats.

MULT — Multiply (Unsigned)

MULT dst,src

Operation: $dst \leftarrow dst \times src$

The 8-bit destination operand (the even numbered register of the register pair) is multiplied by the source operand (8 bits) and the product (16 bits) is stored in the register pair specified by the destination address. Both operands are treated as unsigned integers.

Flags:

- C:** Set if the result is > 255 ; cleared otherwise.
- Z:** Set if the result is "0"; cleared otherwise.
- S:** Set if MSB of the result is a "1"; cleared otherwise.
- V:** Cleared.
- D:** Unaffected.
- H:** Unaffected.

Format:

			Bytes	Cycles	Opcode (Hex)	Addr Mode <u>dst</u> <u>src</u>
opc	src	dst	3	22	84	RR R
				22	85	RR IR
				22	86	RR IM

Examples: Given: Register 00H = 20H, register 01H = 03H, register 02H = 09H, register 03H = 06H:

MULT 00H, 02H → Register 00H = 01H, register 01H = 20H,
register 02H = 09H

MULT 00H, @01H → Register 00H = 00H, register 01H = 0C0H

MULT 00H, #30H → Register 00H = 06H, register 01H = 00H

In the first example, the statement "MULT 00H,02H" multiplies the 8-bit destination operand (in the register 00H of the register pair 00H, 01H) by the source register 02H operand (09H). The 16-bit product, 0120H, is stored in the register pair 00H, 01H.

NEXT — Next

NEXT

Operation: PC \leftarrow @IP
IP \leftarrow IP + 2

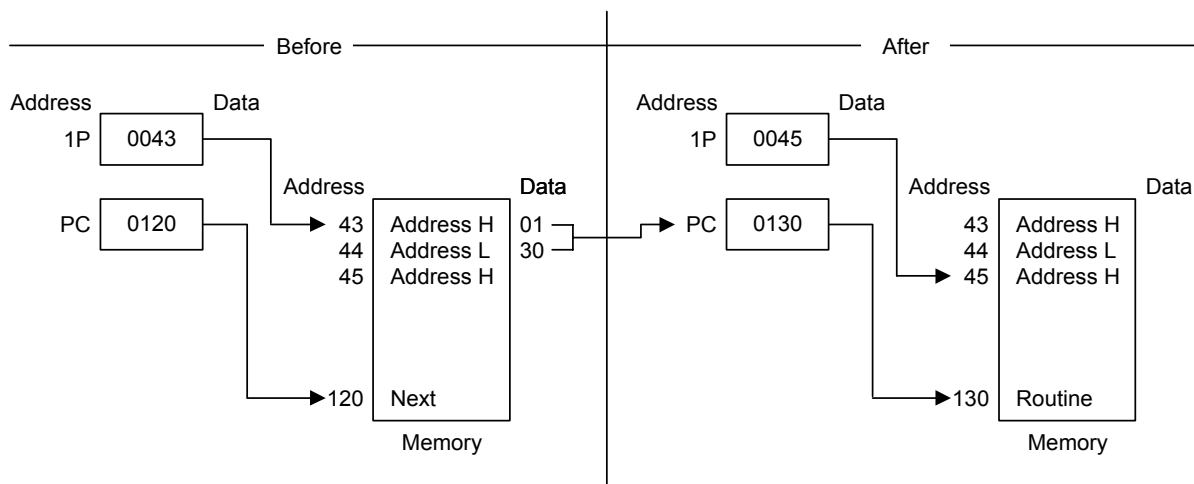
The NEXT instruction is useful when implementing threaded-code languages. The program memory word that is pointed to by the instruction pointer is loaded into the program counter. The instruction pointer is then incremented by two.

Flags: No flags are affected.

Format:

	Bytes	Cycles	Opcode (Hex)
opc	1	10	0F

Example: The following diagram shows an example of how to use the NEXT instruction.



NOP — No Operation

NOP

Operation: No action is performed when the CPU executes this instruction. Typically, one or more NOPs are executed in sequence in order to affect a timing delay of variable duration.

Flags: No flags are affected.

Format:

	Bytes	Cycles	Opcode (Hex)	
<table border="1"><tr><td>opc</td></tr></table>	opc	1	4	FF
opc				

Example: When the instruction NOP is executed in a program, no operation occurs. Instead, there happens a delay in instruction execution time which is of approximately one machine cycle per each **NOP** instruction encountered.

OR — Logical OR

OR dst,src

Operation: dst ← dst OR src

The source operand is logically ORed with the destination operand and the result is stored in the destination. The contents of the source are unaffected. The OR operation results in a "1" being stored whenever either of the corresponding bits in the two operands is a "1", otherwise, a "0" is stored.

Flags:

- C:** Unaffected.
- Z:** Set if the result is "0"; cleared otherwise.
- S:** Set if the result bit 7 is set; cleared otherwise.
- V:** Always cleared to "0".
- D:** Unaffected.
- H:** Unaffected.

Format:

		Bytes	Cycles	Opcode (Hex)	Addr Mode <u>dst</u> <u>src</u>
opc	dst src	2	4	42	r r
			6	43	r lr
opc	src	3	6	44	R R
			6	45	R IR
opc	dst	3	6	46	R IM

Examples: Given: R0 = 15H, R1 = 2AH, R2 = 01H, register 00H = 08H, register 01H = 37H, and register 08H = 8AH

```
OR    R0,R1    →    R0 = 3FH, R1 = 2AH
OR    R0,@R2   →    R0 = 37H, R2 = 01H, register 01H = 37H
OR    00H,01H →    Register 00H = 3FH, register 01H = 37H
OR    01H,@00H →    Register 00H = 08H, register 01H = 0BFH
OR    00H,#02H →    Register 00H = 0AH
```

In the first example, if the working register R0 contains the value 15H and the register R1 the value 2AH, the statement "OR R0,R1" logical-ORs the R0 and R1 register contents and stores the result (3FH) in the destination register R0.

Other examples show the use of the logical OR instruction with various addressing modes and formats.

POP — Pop from Stack

POP dst

Operation: dst ← @SP
 SP ← SP + 1

The contents of the location addressed by the stack pointer are loaded into the destination. The stack pointer is then incremented by one.

Flags: No flags are affected.

Format:

		Bytes	Cycles	Opcode (Hex)	Addr Mode <u>dst</u>
opc	dst	2	8	50	R
			8	51	IR

Examples: Given: Register 00H = 01H, register 01H = 1BH, SPH (0D8H) = 00H, SPL (0D9H) = 0FBH, and stack register 0FBH = 55H:

POP 00H → Register 00H = 55H, SP = 00FCH

POP @00H → Register 00H = 01H, register 01H = 55H, SP = 00FCH

In the first example, the general register 00H contains the value 01H. The statement "POP 00H" loads the contents of the location 00FBH (55H) into the destination register 00H and then increments the stack pointer by one. The register 00H then contains the value 55H and the SP points to the location 00FCH.

POPUD — Pop User Stack (Decrementing)

POPUD dst,src

Operation: dst ← src
IR ← IR – 1

This instruction is used for user-defined stacks in the register file. The contents of the register file location addressed by the user stack pointer are loaded into the destination. The user stack pointer is then decremented.

Flags: No flags are affected.

Format:

			Bytes	Cycles	Opcode (Hex)	Addr Mode <u>dst</u> <u>src</u>
opc	src	dst	3	8	92	R IR

Example: Given: Register 00H = 42H (user stack pointer register), register 42H = 6FH, and register 02H = 70H:

POPUD 02H,@00H → Register 00H = 41H, register 02H = 6FH, register 42H = 6FH

02H If the general register 00H contains the value 42H and the register 42H the value 6FH, the statement "POPUD 02H,@00H" loads the contents of the register 42H into the destination register. The user stack pointer is then decremented by one, leaving the value 41H.

POPUI — Pop User Stack (Incrementing)

POPUI dst,src

Operation: dst ← src
 IR ← IR + 1

The POPUI instruction is used for user-defined stacks in the register file. The contents of the register file location addressed by the user stack pointer are loaded into the destination. The user stack pointer is then incremented.

Flags: No flags are affected.

Format:

			Bytes	Cycles	Opcode (Hex)	Addr Mode <u>dst</u> <u>src</u>
opc	src	dst	3	8	93	R IR

Example: Given: Register 00H = 01H and register 01H = 70H:

POPUI 02H,@00H → Register 00H = 02H, register 01H = 70H, register 02H = 70H

If the general register 00H contains the value 01H and the register 01H the value 70H, the statement "POPUI 02H,@00H" loads the value 70H into the destination general register 02H. The user stack pointer (the register 00H) is then incremented by one, changing its value from 01H to 02H.

PUSH — Push to Stack

PUSH src

Operation: SP ← SP - 1
 @SP ← src

A PUSH instruction decrements the stack pointer value and loads the contents of the source (src) into the location addressed by the decremented stack pointer. The operation then adds the new value to the top of the stack.

Flags: No flags are affected.

Format:

		Bytes	Cycles	Opcode (Hex)	Addr Mode <u>dst</u>
opc	src	2	8 (internal clock)	70	R
			8 (external clock)		
			8 (internal clock)	71	IR
			8 (external clock)		

Examples: Given: Register 40H = 4FH, register 4FH = 0AAH, SPH = 00H, and SPL = 00H:

PUSH 40H → Register 40H = 4FH, stack register 0FFFH = 4FH,
 SPH = 0FFFH, SPL = 0FFFH

PUSH @40H → Register 40H = 4FH, register 4FH = 0AAH, stack register
 0FFFH = 0AAH, SPH = 0FFFH, SPL = 0FFFH

In the first example, if the stack pointer contains the value 0000H, and the general register 40H the value 4FH, the statement "PUSH 40H" decrements the stack pointer from 0000 to 0FFFFH. It then loads the contents of the register 40H into the location 0FFFFH and adds this new value to the top of the stack.

PUSHUD — Push User Stack (Decrementing)

PUSHUD dst,src

Operation: $IR \leftarrow IR - 1$
 $dst \leftarrow src$

This instruction is used to address user-defined stacks in the register file. PUSHUD decrements the user stack pointer and loads the contents of the source into the register addressed by the decremented stack pointer.

Flags: No flags are affected.

Format:

			Bytes	Cycles	Opcode (Hex)	Addr Mode <u>dst</u> <u>src</u>
opc	dst	src	3	8	82	IR R

Example: Given: Register 00H = 03H, register 01H = 05H, and register 02H = 1AH:

PUSHUD @00H,01H → Register 00H = 02H, register 01H = 05H,
 register 02H = 05H

If the user stack pointer (the register 00H, for example) contains the value 03H, the statement "PUSHUD @00H,01H" decrements the user stack pointer by one, leaving the value 02H. The 01H register value, 05H, is then loaded into the register addressed by the decremented user stack pointer.

PUSHUI — Push User Stack (Incrementing)

PUSHUI dst,src

Operation: IR ← IR + 1
dst ← src

This instruction is used for user-defined stacks in the register file. PUSHUI increments the user stack pointer and then loads the contents of the source into the register location addressed by the incremented user stack pointer.

Flags: No flags are affected.

Format:

			Bytes	Cycles	Opcode (Hex)	Addr Mode <u>dst</u> <u>src</u>
opc	dst	src	3	8	83	IR R

Example: Given: Register 00H = 03H, register 01H = 05H, and register 04H = 2AH:

PUSHUI @00H,01H → Register 00H = 04H, register 01H = 05H,
register 04H = 05H

If the user stack pointer (the register 00H, for example) contains the value 03H, the statement "PUSHUI @00H,01H" increments the user stack pointer by one, leaving the value 04H. The 01H register value, 05H, is then loaded into the location addressed by the incremented user stack pointer.

RCF — Reset Carry Flag

RCF RCF

Operation: $C \leftarrow 0$

The carry flag is cleared to logic zero, regardless of its previous value.

Flags: **C:** Cleared to "0".

No other flags are affected.

Format:

	Bytes	Cycles	Opcode (Hex)
opc	1	4	CF

Example: Given: C = "1" or "0":

The instruction RCF clears the carry flag (C) to logic zero.

RET — Return

RET

Operation: PC ← @SP
SP ← SP + 2

The RET instruction is normally used to return to the previously executed procedure at the end of the procedure entered by a CALL instruction. The contents of the location addressed by the stack pointer are popped into the program counter. The next statement to be executed is the one that is addressed by the new program counter value.

Flags: No flags are affected.

Format:

	Bytes	Cycles	Opcode (Hex)
opc	1	10	AF

Example: Given: SP = 00FCH, (SP) = 101AH, and PC = 1234:

RET → PC = 101AH, SP = 00FEH

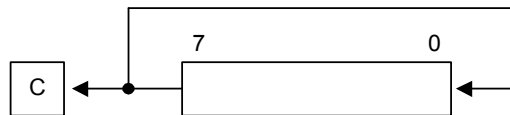
The RET instruction pops the contents of the stack pointer location 00FCH (10H) into the high byte of the program counter. The stack pointer then pops the value in the location 00FEH (1AH) into the PC's low byte and the instruction at the location 101AH is executed. The stack pointer now points to the memory location 00FEH.

RL — Rotate Left

RL dst

Operation: $C \leftarrow \text{dst}(7)$
 $\text{dst}(0) \leftarrow \text{dst}(7)$
 $\text{dst}(n + 1) \leftarrow \text{dst}(n), n = 0-6$

The contents of the destination operand are rotated left one bit position. The initial value of bit 7 is moved to the bit zero (LSB) position and also replaces the carry flag, as shown in the figure below.



Flags:

- C:** Set if the bit rotated from the most significant bit position (bit 7) was "1".
- Z:** Set if the result is "0"; cleared otherwise.
- S:** Set if the result bit 7 is set; cleared otherwise.
- V:** Set if arithmetic overflow occurred; cleared otherwise.
- D:** Unaffected.
- H:** Unaffected.

Format:

		Bytes	Cycles	Opcode (Hex)	Addr Mode <u>dst</u>
opc	dst	2	4	90	R
			4	91	IR

Examples: Given: Register 00H = 0AAH, register 01H = 02H and register 02H = 17H:

RL 00H → Register 00H = 55H, C = "1"
 RL @01H → Register 01H = 02H, register 02H = 2EH, C = "0"

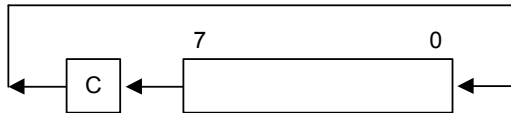
In the first example, if the general register 00H contains the value 0AAH (10101010B), the statement "RL 00H" rotates the 0AAH value left one bit position, leaving the new value 55H (01010101B) and setting the carry (C) and the overflow (V) flags.

RLC — Rotate Left through Carry

RLC dst

Operation: $\text{dst}(0) \leftarrow C$
 $C \leftarrow \text{dst}(7)$
 $\text{dst}(n + 1) \leftarrow \text{dst}(n), n = 0-6$

The contents of the destination operand with the carry flag are rotated left one bit position. The initial value of bit 7 replaces the carry flag (C), and the initial value of the carry flag replaces bit zero.



Flags:

- C:** Set if the bit rotated from the most significant bit position (bit 7) was "1".
- Z:** Set if the result is "0"; cleared otherwise.
- S:** Set if the result bit 7 is set; cleared otherwise.
- V:** Set if arithmetic overflow occurred, that is, if the sign of the destination is changed during the rotation; cleared otherwise.
- D:** Unaffected.
- H:** Unaffected.

Format:

		Bytes	Cycles	Opcode (Hex)	Addr Mode <u>dst</u>
opc	dst	2	4	10	R
			4	11	IR

Examples: Given: Register 00H = 0AAH, register 01H = 02H, and register 02H = 17H, C = "0":

RLC 00H → Register 00H = 54H, C = "1"
 RLC @01H → Register 01H = 02H, register 02H = 2EH, C = "0"

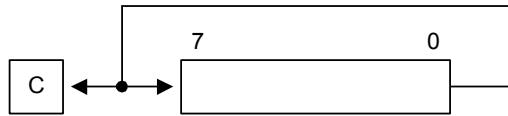
In the first example, if the general register 00H has the value 0AAH (10101010B), the statement "RLC 00H" rotates 0AAH one bit position to the left. The initial value of bit 7 sets the carry flag and the initial value of the C flag replaces bit zero of the register 00H, leaving the value 55H (01010101B). The MSB of the register 00H resets the carry flag to "1" and sets the overflow flag.

RR — Rotate Right

RR dst

Operation: $C \leftarrow \text{dst}(0)$
 $\text{dst}(7) \leftarrow \text{dst}(0)$
 $\text{dst}(n) \leftarrow \text{dst}(n + 1), n = 0-6$

The contents of the destination operand are rotated right one bit position. The initial value of bit zero (LSB) is moved to bit 7 (MSB) and also replaces the carry flag (C).



Flags:

- C:** Set if the bit rotated from the least significant bit position (bit zero) was "1".
- Z:** Set if the result is "0"; cleared otherwise.
- S:** Set if the result bit 7 is set; cleared otherwise.
- V:** Set if arithmetic overflow occurred, that is, if the sign of the destination is changed during the rotation; cleared otherwise.
- D:** Unaffected.
- H:** Unaffected.

Format:

		Bytes	Cycles	Opcode (Hex)	Addr Mode <u>dst</u>
opc	dst	2	4	E0	R
			4	E1	IR

Examples: Given: Register 00H = 31H, register 01H = 02H, and register 02H = 17H:

RR 00H → Register 00H = 98H, C = "1"
 RR @01H → Register 01H = 02H, register 02H = 8BH, C = "1"

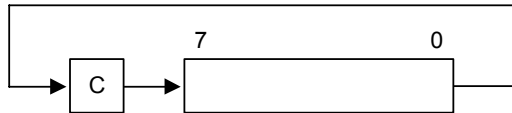
In the first example, if the general register 00H contains the value 31H (00110001B), the statement "RR 00H" rotates this value one bit position to the right. The initial value of bit zero is moved to bit 7, leaving the new value 98H (10011000B) in the destination register. The initial bit zero also resets the C flag to "1" and the sign flag and the overflow flag are also set to "1".

RRC — Rotate Right through Carry

RRC dst

Operation: dst (7) ← C
 C ← dst (0)
 dst (n) ← dst (n + 1), n = 0–6

The contents of the destination operand and the carry flag are rotated right one bit position. The initial value of bit zero (LSB) replaces the carry flag, and the initial value of the carry flag replaces bit 7 (MSB).



Flags:

- C:** Set if the bit rotated from the least significant bit position (bit zero) was "1".
- Z:** Set if the result is "0" cleared otherwise.
- S:** Set if the result bit 7 is set; cleared otherwise.
- V:** Set if arithmetic overflow occurred, that is, if the sign of the destination is changed during the rotation; cleared otherwise.
- D:** Unaffected.
- H:** Unaffected.

Format:

		Bytes	Cycles	Opcode (Hex)	Addr Mode <u>dst</u>
opc	dst	2	4	C0	R
			4	C1	IR

Examples: Given: Register 00H = 55H, register 01H = 02H, register 02H = 17H, and C = "0":

RRC 00H → Register 00H = 2AH, C = "1"

RRC @01H → Register 01H = 02H, register 02H = 0BH, C = "1"

In the first example, if the general register 00H contains the value 55H (01010101B), the statement "RRC 00H" rotates this value one bit position to the right. The initial value of bit zero ("1") replaces the carry flag and the initial value of the C flag ("1") replaces bit 7. This leaves the new value 2AH (00101010B) in the destination register 00H. The sign flag and the overflow flag are both cleared to "0".

SB0 — Select Bank 0

SB0

Operation: BANK ← 0

The SB0 instruction clears the bank address flag in the FLAGS register (FLAGS.0) to logic zero, selecting the bank 0 register addressing in the set 1 area of the register file.

Flags: No flags are affected.

Format:

	Bytes	Cycles	Opcode (Hex)	
<table border="1"><tr><td>opc</td></tr></table>	opc	1	4	4F
opc				

Example: The statement **SB0** clears FLAGS.0 to "0", selecting the bank 0 register addressing.

SB1 — Select Bank 1

SB1

Operation: BANK ← 1

The SB1 instruction sets the bank address flag in the FLAGS register (FLAGS.0) to logic one, selecting the bank 1 register addressing in the set 1 area of the register file.

NOTE: Bank 1 is not implemented in some KS88-series microcontrollers.

Flags: No flags are affected.

Format:

	Bytes	Cycles	Opcode (Hex)
opc	1	4	5F

Example: The statement **SB1** sets FLAGS.0 to "1", selectin the bank 1 register addressing (if bank 1 is implemented in the microcontrooler's internla register file).

SBC — Subtract with Carry

SBC dst,src

Operation: $dst \leftarrow dst - src - c$

The source operand, along with the current value of the carry flag, is subtracted from the destination operand and the result is stored in the destination. The contents of the source are unaffected. Subtraction is performed by adding the two's-complement of the source operand to the destination operand. In multiple precision arithmetic, this instruction permits the carry ("borrow") from the subtraction of the low-order operands to be subtracted from the subtraction of high-order operands.

Flags:

- C:** Set if a borrow occurred ($src > dst$); cleared otherwise.
- Z:** Set if the result is "0"; cleared otherwise.
- S:** Set if the result is negative; cleared otherwise.
- V:** Set if arithmetic overflow occurred, that is, if the operands were of opposite sign and the sign of the result is the same as the sign of the source; cleared otherwise.
- D:** Always set to "1".
- H:** Cleared if there is a carry from the most significant bit of the low-order four bits of the result; set otherwise, indicating a "borrow"

Format:

			Bytes	Cycles	Opcode (Hex)	Addr Mode <u>dst</u> <u>src</u>
opc	dst src		2	4	32	r r
				6	33	r lr
opc	src	dst	3	6	34	R R
				6	35	R IR
opc	dst	src	3	6	36	R IM

Examples: Given: R1 = 10H, R2 = 03H, C = "1", register 01H = 20H, register 02H = 03H, and register 03H = 0AH:

SBC	R1,R2	→	R1 = 0CH, R2 = 03H
SBC	R1,@R2	→	R1 = 05H, R2 = 03H, register 03H = 0AH
SBC	01H,02H	→	Register 01H = 1CH, register 02H = 03H
SBC	01H,@02H	→	Register 01H = 15H, register 02H = 03H, register 03H = 0AH
SBC	01H,#8AH	→	Register 01H = 95H; C, S, and V = "1"

In the first example, if the working register R1 contains the value 10H and the register R2 the value 03H, the statement "SBC R1,R2" subtracts the source value (03H) and the C flag value ("1") from the destination (10H) and then stores the result (0CH) in the register R1.



SCF — Set Carry Flag

SCF

Operation: $C \leftarrow 1$

The carry flag (C) is set to logic one, regardless of its previous value.

Flags: **C:** Set to "1".
No other flags are affected.

Format:

	Bytes	Cycles	Opcode (Hex)	
<table border="1"><tr><td>opc</td></tr></table>	opc	1	4	DF
opc				

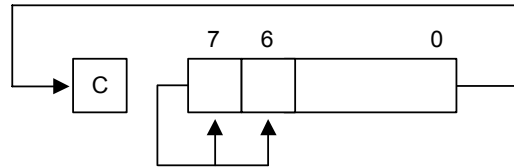
Example: The statement **SCF** sets the carry flag to "1".

SRA — Shift Right Arithmetic

SRA dst

Operation: dst (7) ← dst (7)
 C ← dst (0)
 dst (n) ← dst (n + 1), n = 0–6

An arithmetic shift-right of one bit position is performed on the destination operand. Bit zero (the LSB) replaces the carry flag. The value of bit 7 (the sign bit) is unchanged and is shifted into the bit position 6.



Flags:

- C:** Set if the bit shifted from the LSB position (bit zero) was "1".
- Z:** Set if the result is "0"; cleared otherwise.
- S:** Set if the result is negative; cleared otherwise.
- V:** Always cleared to "0".
- D:** Unaffected.
- H:** Unaffected.

Format:

		Bytes	Cycles	Opcode (Hex)	Addr Mode <u>dst</u>
opc	dst	2	4	D0	R
			4	D1	IR

Examples: Given: Register 00H = 9AH, register 02H = 03H, register 03H = 0BCH, and C = "1":

SRA 00H → Register 00H = 0CD, C = "0"
 SRA @02H → Register 02H = 03H, register 03H = 0DEH, C = "0"

In the first example, if the general register 00H contains the value 9AH (10011010B), the statement "SRA 00H" shifts the bit values in the register 00H right one bit position. Bit zero ("0") clears the C flag and bit 7 ("1") is then shifted into the bit 6 position (bit 7 remains unchanged). This leaves the value 0CDH (11001101B) in the destination register 00H.

SRP/SRP0/SRP1 — Set Register Pointer

SRP src

SRP0 src

SRP1 src

Operation: If src (1) = 1 and src (0) = 0 then: RP0 (3–7) ← src (3–7)
 If src (1) = 0 and src (0) = 1 then: RP1 (3–7) ← src (3–7)
 If src (1) = 0 and src (0) = 0 then: RP0 (4–7) ← src (4–7),
 RP0 (3) ← 0
 RP1 (4–7) ← src (4–7),
 RP1 (3) ← 1

The source data bits one and zero (LSB) determine whether to write one or both of the register pointers, RP0 and RP1. Bits 3–7 of the selected register pointer are written unless both register pointers are selected. RP0.3 is then cleared to logic zero and RP1.3 is set to logic one.

Flags: No flags are affected.

Format:

		Bytes	Cycles	Opcode (Hex)	Addr Mode <u>src</u>		
	<table border="1"><tr><td>opc</td><td>src</td></tr></table>	opc	src	2	4	31	IM
opc	src						

Examples: The statement **SRP #40H** sets the register pointer 0 (RP0) at the location 0D6H to 40H and the register pointer 1 (RP1) at the location 0D7H to 48 H.

The statement "SRP0 #50H" would set RP0 to 50H, and the statement "SRP1 #68H" would set RP1 to 68H.

NOTE: Before execute the STOP instruction, You must set the STPCON register as "10100101b".
Otherwise the STOP instruction will not execute.

STOP — Stop Operation

STOP

Operation: The STOP instruction stops the both the CPU clock and system clock and causes the microcontroller to enter Stop mode. During Stop mode, the contents of on-chip CPU registers, peripheral registers, and I/O port control and data registers are retained. Stop mode can be released by an external reset operation or by external interrupts. For the reset operation, the RESET pin must be held to Low level until the required oscillation stabilization interval has elapsed.

Flags: No flags are affected.

Format:

	Bytes	Cycles	Opcode (Hex)	Addr <u>dst</u>	Mode <u>src</u>
opc	1	4	7F	-	-

Example: The statement **STOP** halts all microcontroller operations.

SUB — Subtract

SUB dst,src

Operation: dst ← dst – src

The source operand is subtracted from the destination operand and the result is stored in the destination. The contents of the source are unaffected. Subtraction is performed by adding the two's complement of the source operand to the destination operand.

Flags:

- C:** Set if a "borrow" occurred; cleared otherwise.
- Z:** Set if the result is "0"; cleared otherwise.
- S:** Set if the result is negative; cleared otherwise.
- V:** Set if arithmetic overflow occurred, that is, if the operands were of opposite signs and the sign of the result is of the same as the sign of the source operand; cleared otherwise.
- D:** Always set to "1".
- H:** Cleared if there is a carry from the most significant bit of the low-order four bits of the result; set otherwise indicating a "borrow".

Format:

		Bytes	Cycles	Opcode (Hex)	Addr Mode <u>dst</u> <u>src</u>
opc	dst src	2	4	22	r r
			6	23	r lr
opc	src	3	6	24	R R
			6	25	R IR
opc	dst	3	6	26	R IM

Examples: Given: R1 = 12H, R2 = 03H, register 01H = 21H, register 02H = 03H, register 03H = 0AH:

SUB	R1,R2	→	R1 = 0FH, R2 = 03H
SUB	R1,@R2	→	R1 = 08H, R2 = 03H
SUB	01H,02H	→	Register 01H = 1EH, register 02H = 03H
SUB	01H,@02H	→	Register 01H = 17H, register 02H = 03H
SUB	01H,#90H	→	Register 01H = 91H; C, S, and V = "1"
SUB	01H,#65H	→	Register 01H = 0BCH; C and S = "1", V = "0"

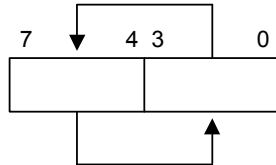
In the first example, if the working register R1 contains the value 12H and if the register R2 contains the value 03H, the statement "SUB R1,R2" subtracts the source value (03H) from the destination value (12H) and stores the result (0FH) in the destination register R1.

SWAP — Swap Nibbles

SWAP dst

Operation: dst (0 – 3) ↔ dst (4 – 7)

The contents of the lower four bits and the upper four bits of the destination operand are swapped.



Flags:

- C:** Undefined.
- Z:** Set if the result is "0"; cleared otherwise.
- S:** Set if the result bit 7 is set; cleared otherwise.
- V:** Undefined.
- D:** Unaffected.
- H:** Unaffected.

Format:

		Bytes	Cycles	Opcode (Hex)	Addr Mode
opc	dst	2	4	F0	R
			4	F1	IR

Examples: Given: Register 00H = 3EH, register 02H = 03H, and register 03H = 0A4H:

SWAP 00H → Register 00H = 0E3H
 SWAP @02H → Register 02H = 03H, register 03H = 4AH

In the first example, if the general register 00H contains the value 3EH (00111110B), the statement "SWAP 00H" swaps the lower and the upper four bits (nibbles) in the 00H register, leaving the value 0E3H (11100011B).

TCM — Test Complement under Mask

TCM dst,src

Operation: (NOT dst) AND src

This instruction tests selected bits in the destination operand for a logic one value. The bits to be tested are specified by setting a "1" bit in the corresponding position of the source operand (mask). The TCM statement complements the destination operand, which is then ANDed with the source mask. The zero (Z) flag can then be checked to determine the result. The destination and the source operands are unaffected.

Flags:

- C:** Unaffected.
- Z:** Set if the result is "0"; cleared otherwise.
- S:** Set if the result bit 7 is set; cleared otherwise.
- V:** Always cleared to "0".
- D:** Unaffected.
- H:** Unaffected.

Format:

		Bytes	Cycles	Opcode (Hex)	Addr Mode <u>dst</u>	<u>src</u>
opc	dst src	2	4	62	r	r
			6	63	r	lr
opc	src	3	6	64	R	R
			6	65	R	IR
opc	dst	3	6	66	R	IM

Examples: Given: R0 = 0C7H, R1 = 02H, R2 = 12H, register 00H = 2BH, register 01H = 02H, and register 02H = 23H:

TCM	R0,R1	→	R0 = 0C7H, R1 = 02H, Z = "1"
TCM	R0,@R1	→	R0 = 0C7H, R1 = 02H, register 02H = 23H, Z = "0"
TCM	00H,01H	→	Register 00H = 2BH, register 01H = 02H, Z = "1"
TCM	00H,@01H	→	Register 00H = 2BH, register 01H = 02H, register 02H = 23H, Z = "1"
TCM	00H,#34	→	Register 00H = 2BH, Z = "0"

In the first example, if the working register R0 contains the value 0C7H (11000111B) and the register R1 the value 02H (00000010B), the statement "TCM R0,R1" tests bit one in the destination register for a "1" value. Because the mask value corresponds to the test bit, the Z flag is set to logic one and can be tested to determine the result of the TCM operation.

TM — Test under Mask

TM dst,src

Operation: dst AND src

This instruction tests selected bits in the destination operand for a logic zero value. The bits to be tested are specified by setting a "1" bit in the corresponding position of the source operand (mask), which is ANDed with the destination operand. The zero (Z) flag can then be checked to determine the result. The destination and the source operands are unaffected.

Flags:

- C:** Unaffected.
- Z:** Set if the result is "0"; cleared otherwise.
- S:** Set if the result bit 7 is set; cleared otherwise.
- V:** Always reset to "0".
- D:** Unaffected.
- H:** Unaffected.

Format:

		Bytes	Cycles	Opcode (Hex)	Addr Mode <u>dst</u> <u>src</u>
opc	dst src	2	4	72	r r
			6	73	r lr
opc	src dst	3	6	74	R R
			6	75	R IR
opc	dst src	3	6	76	R IM

Examples: Given: R0 = 0C7H, R1 = 02H, R2 = 18H, register 00H = 2BH, register 01H = 02H, and register 02H = 23H:

TM	R0,R1	→	R0 = 0C7H, R1 = 02H, Z = "0"
TM	R0,@R1	→	R0 = 0C7H, R1 = 02H, register 02H = 23H, Z = "0"
TM	00H,01H	→	Register 00H = 2BH, register 01H = 02H, Z = "0"
TM	00H,@01H	→	Register 00H = 2BH, register 01H = 02H, register 02H = 23H, Z = "0"
TM	00H,#54H	→	Register 00H = 2BH, Z = "1"

In the first example, if the working register R0 contains the value 0C7H (11000111B) and the register R1 the value 02H (0000010B), the statement "TM R0,R1" tests bit one in the destination register for a "0" value. Because the mask value does not match the test bit, the Z flag is cleared to logic zero and can be tested to determine the result of the TM operation.

WFI — Wait for Interrupt

WFI

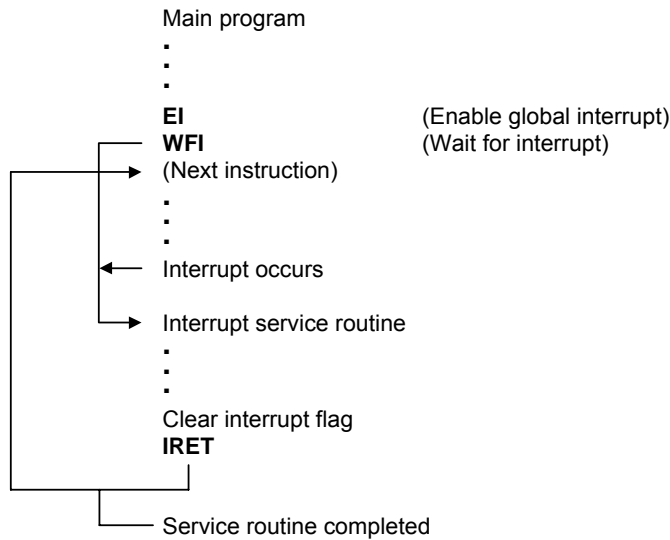
Operation: The CPU is effectively halted before an interrupt occurs, except that DMA transfers can still take place during this wait state. The WFI status can be released by an internal interrupt, including a fast interrupt.

Flags: No flags are affected.

Format:

	Bytes	Cycles	Opcode (Hex)
opc	1	4n (n = 1, 2, 3, ...)	3F

Example: The following sample program structure shows the sequence of operations that follow a "WFI" statement:



XOR — Logical Exclusive OR

XOR dst,src

Operation: dst ← dst XOR src

The source operand is logically exclusive-ORed with the destination operand and the result is stored in the destination. The exclusive-OR operation results in a "1" bit being stored whenever the corresponding bits in the operands are different. Otherwise, a "0" bit is stored.

Flags:

- C:** Unaffected.
- Z:** Set if the result is "0"; cleared otherwise.
- S:** Set if the result bit 7 is set; cleared otherwise.
- V:** Always reset to "0".
- D:** Unaffected.
- H:** Unaffected.

Format:

			Bytes	Cycles	Opcode (Hex)	Addr Mode <u>dst</u> <u>src</u>
opc	dst src		2	4	B2	r r
				6	B3	r lr
opc	src	dst	3	6	B4	R R
				6	B5	R IR
opc	dst	src	3	6	B6	R IM

Examples: Given: R0 = 0C7H, R1 = 02H, R2 = 18H, register 00H = 2BH, register 01H = 02H, and register 02H = 23H:

```

XOR    R0,R1    →    R0 = 0C5H, R1 = 02H
XOR    R0,@R1   →    R0 = 0E4H, R1 = 02H, register 02H = 23H
XOR    00H,01H  →    Register 00H = 29H, register 01H = 02H
XOR    00H,@01H →    Register 00H = 08H, register 01H = 02H,
                    register 02H = 23H
XOR    00H,#54H →    Register 00H = 7FH

```

In the first example, if the working register R0 contains the value 0C7H and if the register R1 contains the value 02H, the statement "XOR R0,R1" logically exclusive-ORs the R1 value with the R0 value and stores the result (0C5H) in the destination register R0.

7

CLOCK CIRCUIT

OVERVIEW

The clock frequency generated for the Main clock of S3C84H5/F84H5 by an external crystal can range from 1 MHz to 10 MHz. The maximum CPU clock frequency is 10 MHz. The X_{IN} and X_{OUT} pins connect the external oscillator or clock source to the on-chip clock circuit. Also the subsystem clock frequency for the Watch timer by an external crystal can range from 30 kHz to 35 kHz. The XT_{IN} and XT_{OUT} pins connect the external oscillator or clock source to the on-chip clock circuit.

SYSTEM CLOCK CIRCUIT

The system clock circuit has the following components:

- External crystal or ceramic resonator oscillation source (or an external clock source)
- Oscillator stop and wake-up functions
- Programmable frequency divider for the CPU clock (f_{xx} divided by 1, 2, 8, or 16)
- System clock control register, CLKCON
- Oscillator control register, OSCCON and STOP control register, STPCON

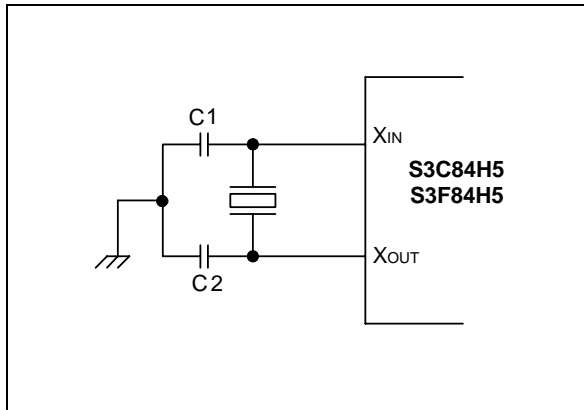


Figure 7-1. Main Oscillator Circuit
(Crystal or Ceramic Oscillator)

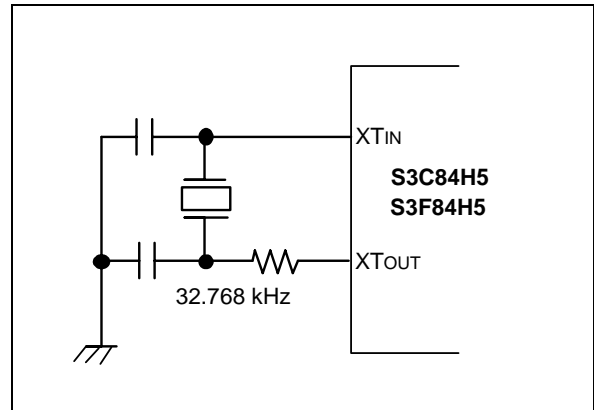


Figure 7-2. Sub-System Oscillator Circuit
(Crystal Oscillator)

CLOCK STATUS DURING POWER-DOWN MODES

The two power-down modes, Stop mode and Idle mode, affect the system clock as follows:

- In Stop mode, the main oscillator is halted. Stop mode is released, and the oscillator is started, by a reset operation or an external interrupt (with RC delay noise filter). , and can be released by internal interrupt too when the sub-system oscillator is running and watch timer is operating with sub-system clock.
- In Idle mode, the internal clock signal is gated to the CPU, but not to interrupt structure, timers and timer/ counters. Idle mode is released by a reset or by an external or internal interrupt.

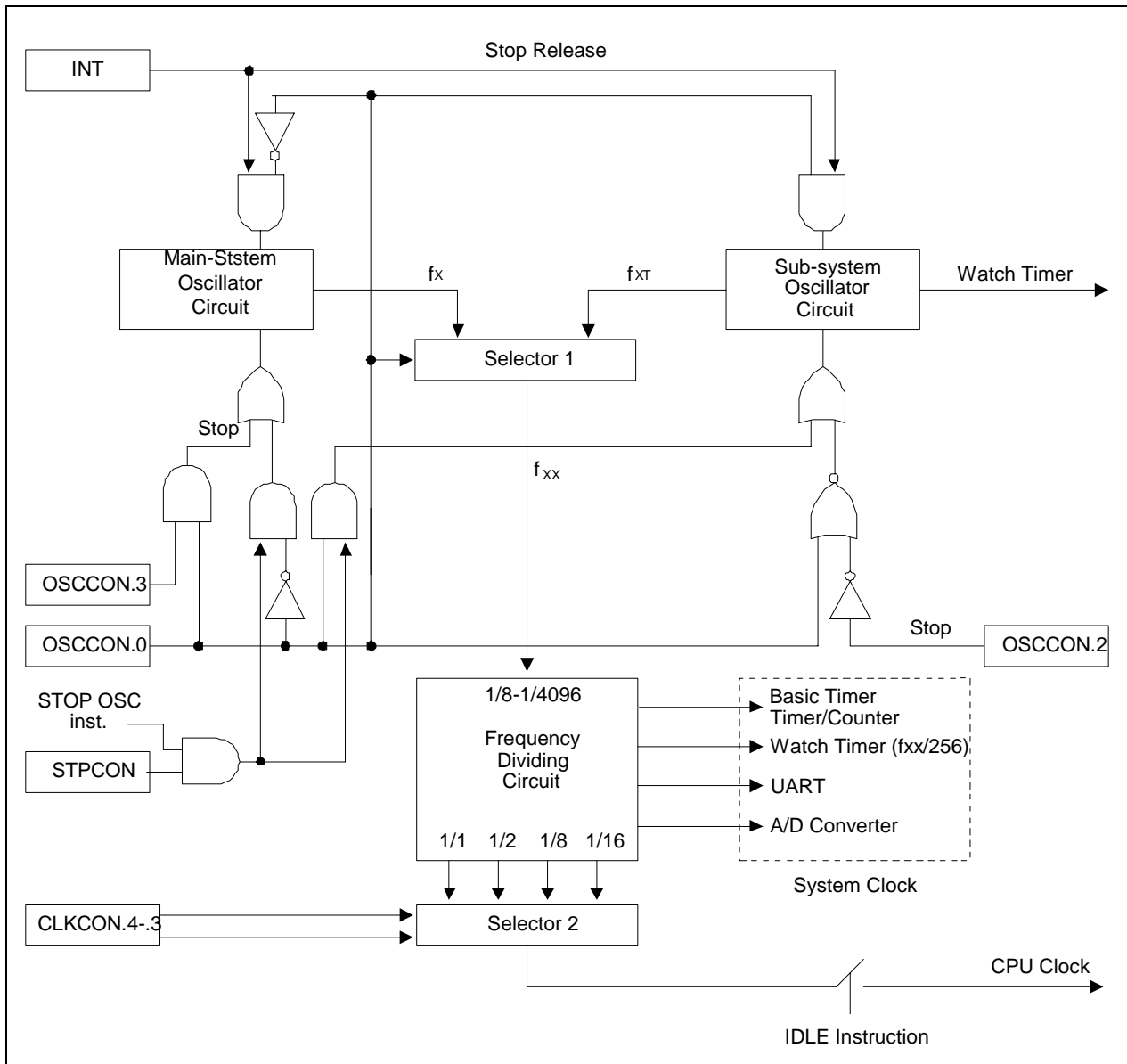


Figure 7-3. System Clock Circuit Diagram

SYSTEM CLOCK CONTROL REGISTER (CLKCON)

The system clock control register, CLKCON, is located in set 1, address D4H. It is read/write addressable and has the following functions:

- Oscillator frequency divide-by value

After the main oscillator is activated, and the $fx/16$ (the slowest clock speed) is selected as the CPU clock. If necessary, you can then increase the CPU clock speed $fx/8$, $fx/2$, or $fx/1$.

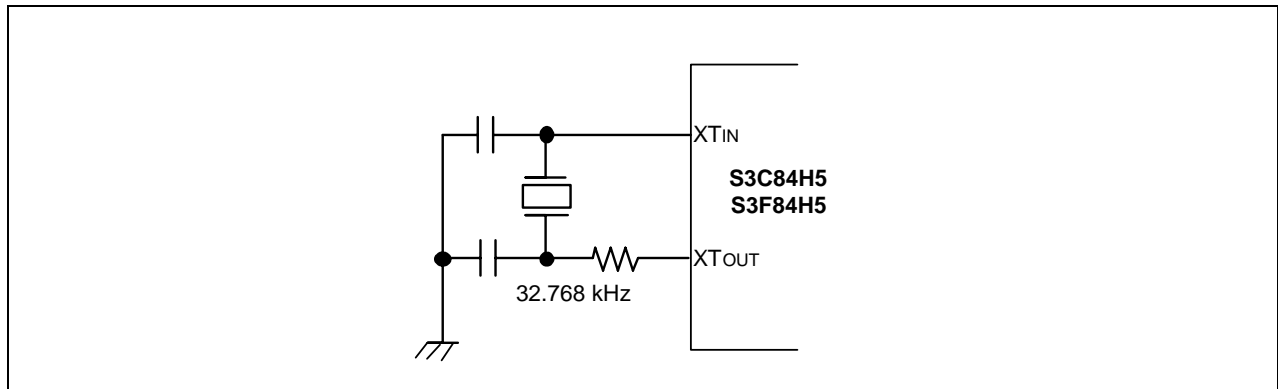


Figure 7-4. System Clock Control Register (CLKCON)

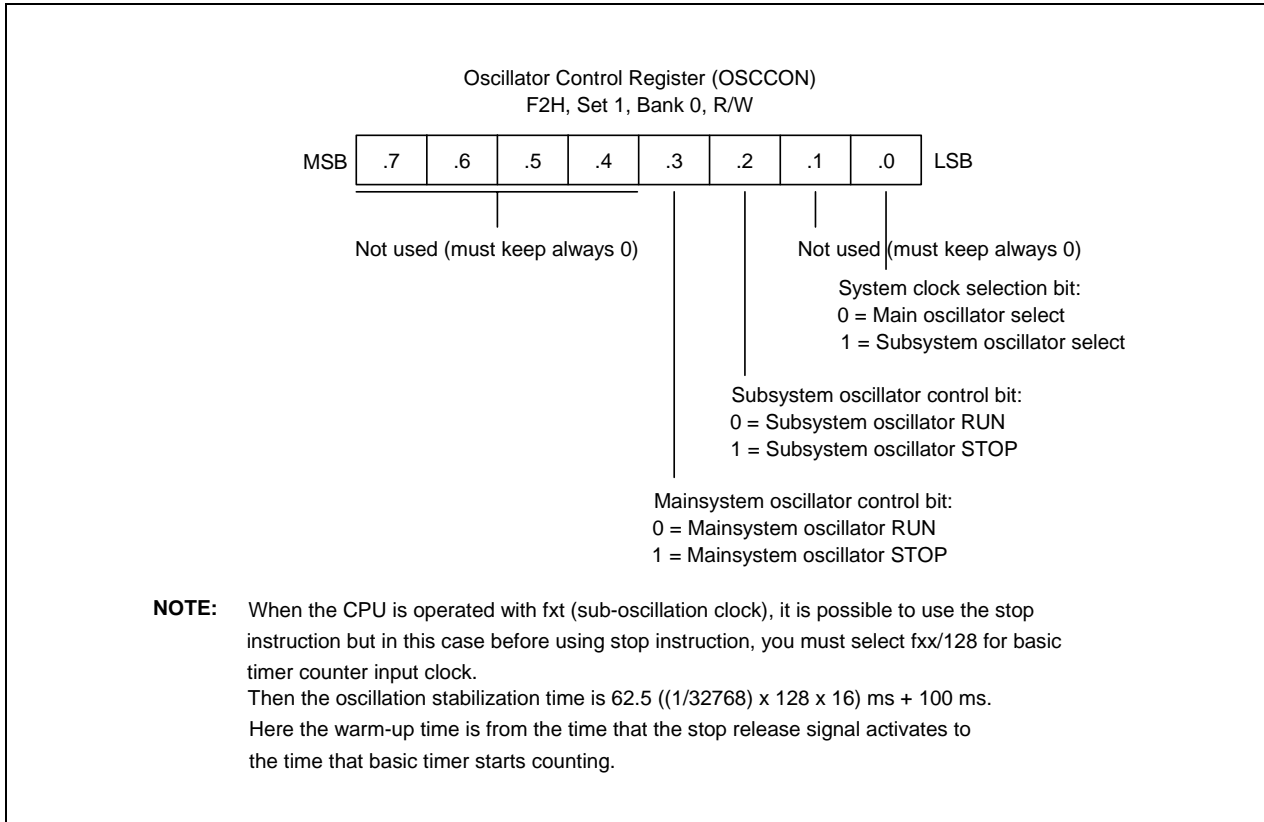


Figure 7-5. Oscillator Control Register (OSCCON)

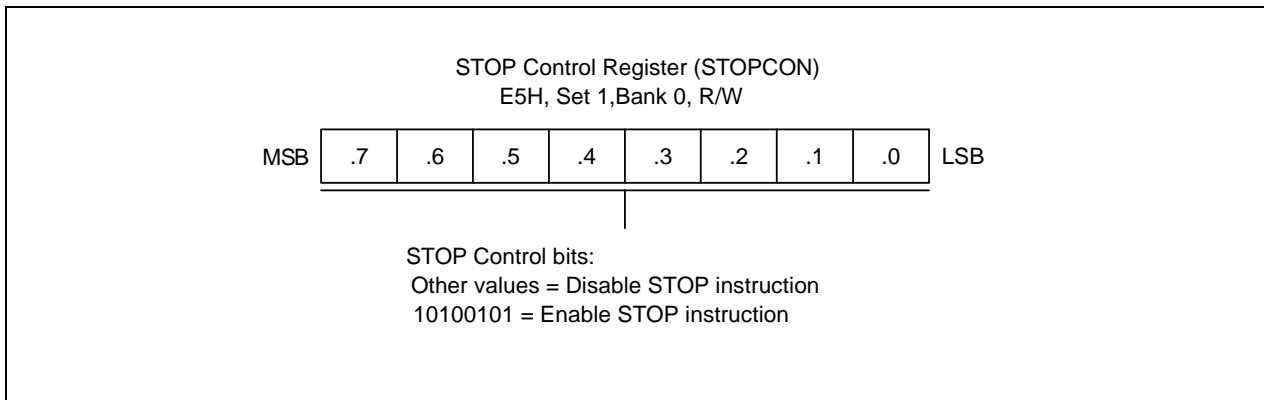


Figure 7-6. STOP Control Register (STOPCON)

8

RESET AND POWER-DOWN

SYSTEM RESET

OVERVIEW

During a power-on reset, the voltage at V_{DD} goes to High level and the RESET pin is forced to Low level. The RESET signal is input through a Schmitt trigger circuit where it is then synchronized with the CPU clock. This procedure brings S3C84H5/F84H5 into a known operating status.

To allow time for internal CPU clock oscillation to stabilize, the RESET pin must be held to Low level for a minimum time interval after the power supply comes within tolerance. The minimum required oscillation stabilization time for a reset operation is 1 millisecond.

Whenever a reset occurs during normal operation (that is, when both V_{DD} and RESET are High level), the RESET pin is forced Low and the reset operation starts. All system and peripheral control registers are then reset to their default hardware values

In summary, the following sequence of events occurs during a reset operation:

- Interrupt is disabled.
- The watchdog function (basic timer) is enabled.
- Ports 0-3 are set to input mode
- Peripheral control and data registers are disabled and reset to their default hardware values.
- The program counter (PC) is loaded with the program reset address in the ROM, 0100H.
- When the programmed oscillation stabilization time interval has elapsed, the instruction stored in ROM location 0100H (and 0101H) is fetched and executed.

NORMAL MODE RESET OPERATION

In normal (masked ROM) mode, the TEST pin is tied to V_{SS} . A reset enables access to the 16-Kbyte on-chip ROM.

NOTE

To program the duration of the oscillation stabilization interval, you make the appropriate settings to the basic timer control register, BTCON, *before* entering Stop mode. Also, if you do not want to use the basic timer watchdog function (which causes a system reset if a basic timer counter overflow occurs), you can disable it by writing '1010B' to the upper nibble of BTCON.

HARDWARE RESET VALUES

Table 8-1, 8-2, and 8-3 list the reset values for CPU and system registers, peripheral control registers, and peripheral data registers following a reset operation. The following notation is used to represent reset values:

- A "1" or a "0" shows the reset bit value as logic one or logic zero, respectively.
- An "x" means that the bit value is undefined after a reset.
- A dash ("–") means that the bit is either not used or not mapped, but read 0 is the bit value.

Table 8-1. S3C84H5/F84H5 Set 1 Register values after RESET

Register Name	Mnemonic	Address		Bit values after RESET								
		Dec	Hex	7	6	5	4	3	2	1	0	
Timer B control register	TBCON	208	D0H	0	0	0	0	0	0	0	0	0
Timer B data register (high byte)	TBDATAH	209	D1H	1	1	1	1	1	1	1	1	1
Timer B data register (low byte)	TBDATAL	210	D2H	1	1	1	1	1	1	1	1	1
Basic timer control register	BTCON	211	D3H	0	0	0	0	0	0	0	0	0
Clock Control register	CLKCON	212	D4H	0	0	0	0	0	0	0	0	0
System flags register	FLAGS	213	D5H	x	x	x	x	x	x	x	0	0
Register pointer 0	RP0	214	D6H	1	1	0	0	0	–	–	–	–
Register pointer 1	RP1	215	D7H	1	1	0	0	1	–	–	–	–
Stack pointer (high byte)	SPH	216	D8H	x	x	x	x	x	x	x	x	x
Stack pointer (low byte)	SPL	217	D9H	x	x	x	x	x	x	x	x	x
Instruction pointer (high byte)	IPH	218	DAH	x	x	x	x	x	x	x	x	x
Instruction pointer (low byte)	IPL	219	DBH	x	x	x	x	x	x	x	x	x
Interrupt request register	IRQ	220	DCH	0	0	0	0	0	0	0	0	0
Interrupt mask register	IMR	221	DDH	x	x	x	x	x	x	x	x	x
System mode register	SYM	222	DEH	0	0	0	x	x	x	x	0	0
Register page pointer	PP	223	DFH	0	0	0	0	0	0	0	0	0

Table 8-2. S3C84H5/F84H5 Set 1, Bank 0 Register values after RESET

Register Name	Mnemonic	Address		Bit values after Reset								
		Dec	Hex	7	6	5	4	3	2	1	0	
Port 0 data register	P0	224	E0H	0	0	0	0	0	0	0	0	0
Port 1 data register	P1	225	E1H	0	0	0	0	0	0	0	0	0
Port 2 data register	P2	226	E2H	0	0	0	0	0	0	0	0	0
Port 3 data register	P3	227	E3H	0	0	0	0	0	0	0	0	0
Location E4H is not mapped												
STOP control register	STOPCON	229	E5H	0	0	0	0	0	0	0	0	0
Port 0 control register (high byte)	P0CON	230	E6H	0	0	0	0	0	0	0	0	0
Location FBH is not mapped												
Port 1 control register (high byte)	P1CONH	232	E8H	0	0	0	0	0	0	0	0	0
Port 1 control register (low byte)	P1CONL	233	E9H	0	0	0	0	0	0	0	0	0
Port 1 interrupt pending register	P1INTPND	234	EAH	0	0	0	0	0	0	0	0	0
Port 1 interrupt control register	P1INT	235	EBH	0	0	0	0	0	0	0	0	0
Port 2 control register (high byte)	P2CONH	234	ECH	0	0	0	0	0	0	0	0	0
Port 2 control register (low byte)	P2CONL	235	EDH	0	0	0	0	0	0	0	0	0
Location EEH is not mapped												
Port 3 control register (low byte)	P3CONL	239	EFH	0	0	0	0	0	0	0	0	0
Location F0H, F1H is not mapped												
Oscillator control register	OSCCON	242	F2H	0	0	0	0	0	0	0	0	0
Location FBH is not mapped												
UART pending register	UARTPND	244	F4H	0	0	0	0	0	0	0	0	0
UART data register	UDATA	245	F5H	1	1	1	1	1	1	1	1	1
UART control register	UARTCON	246	F6H	0	0	0	0	0	0	0	0	0
A/D converter control register	ADCON	247	F7H	0	0	0	0	0	0	0	0	0
A/D converter data register(high byte)	ADDATAH	248	F8H	0	0	0	0	0	0	0	0	0
A/D converter data register(low byte)	ADDATAL	249	F9H	0	0	0	0	0	0	0	0	0
Port 2 pull-up enable control register	P2PUR	250	FAH	0	0	0	0	0	0	0	0	0
Location FBH is not mapped												
Location FCH is factory use only.												
Basic timer counter register	BTCNT	253	FDH	0	0	0	0	0	0	0	0	0
Location FEH is not mapped.												
Interrupt priority register	IPR	255	FFH	x	x	x	x	x	x	x	x	x

Table 8-3. S3C84H5/F84H5 Set 1, Bank 1 Register values after RESET

Register Name	Mnemonic	Address		Bit values after Reset								
		Dec	Hex	7	6	5	4	3	2	1	0	
Timer A, 1 interrupt pending register	TINTPND	224	E0H	0	0	0	0	0	0	0	0	0
Timer A control register	TACON	225	E1H	0	0	0	0	0	0	0	0	0
Timer A data register	TADATA	226	E2H	1	1	1	1	1	1	1	1	1
Timer A counter register	TACNT	227	E3H	0	0	0	0	0	0	0	0	0
Timer 1(0) data register (high byte)	T1DATAH0	228	E4H	1	1	1	1	1	1	1	1	1
Timer 1(0) data register (low byte)	T1DATAL0	229	E5H	1	1	1	1	1	1	1	1	1
Timer 1(1) data register (high byte)	T1DATAH1	230	E6H	1	1	1	1	1	1	1	1	1
Timer 1(1) data register (low byte)	T1DATAL1	231	E7H	1	1	1	1	1	1	1	1	1
Timer 1(0) control register	T1CON0	232	E8H	0	0	0	0	0	0	0	0	0
Timer 1(1) control register	T1CON1	233	E9H	0	0	0	0	0	0	0	0	0
Timer 1(0) counter register (high byte)	T1CNTH0	234	EAH	0	0	0	0	0	0	0	0	0
Timer 1(0) counter register (low byte)	T1CNTL0	235	EBH	0	0	0	0	0	0	0	0	0
Timer 1(1) counter register (high byte)	T1CNTH1	236	ECH	0	0	0	0	0	0	0	0	0
Timer 1(1) counter register (low byte)	T1CNTL1	237	EDH	0	0	0	0	0	0	0	0	0
UART baud rate data register (high)	BRDATAH	238	EEH	1	1	1	1	1	1	1	1	1
UART baud rate data register (low)	BRDATAL	239	EFH	1	1	1	1	1	1	1	1	1
SIO pre-scalar register	SIOPS	240	F0H	0	0	0	0	0	0	0	0	0
SIO data register	SIODATA	241	F1H	0	0	0	0	0	0	0	0	0
Serial I/O control register	SIOCON	242	F2H	0	0	0	0	0	0	0	0	0
PWM data register (High)	PWMDATAH	243	F3H	0	0	0	0	0	0	0	0	0
PWM data register (LOW)	PWMDATAL	244	F4H	0	0	0	0	0	0	0	0	0
PWM control register	PWMCON	245	F5H	0	0	-	0	0	0	0	0	0
Location F6H, F7H is not mapped												
Watch timer control register	WTCON	248	F8H	0	0	0	0	0	0	0	0	0
Location F9H–FFH are not mapped												

POWER-DOWN MODES

STOP MODE

Stop mode is invoked by the instruction STOP (opcode 7FH). In Stop mode, the operation of the CPU and all peripherals is halted. That is, the on-chip main oscillator stops and the supply current is reduced to less than 3 μ A except for the current consumption of LVR (Low voltage Reset) circuit. All system functions stop when the clock "freezes," but data stored in the internal register file is retained. Stop mode can be released in one of two ways: by a reset or by interrupts.

NOTE

Do not use stop mode if you are using an external clock source because X_{IN} input must be restricted internally to V_{SS} to reduce current leakage.

Using RESET to Release Stop Mode

Stop mode is released when the RESET signal is released and returns to high level: all system and peripheral control registers are reset to their default hardware values and the contents of all data registers are retained. A reset operation automatically selects a slow clock (1/16) because CLKCON.3 and CLKCON.4 are cleared to '00B'. After the programmed oscillation stabilization interval has elapsed, the CPU starts the system initialization routine by fetching the program instruction stored in ROM location 0100H (and 0101H).

Using an External Interrupt to Release Stop Mode

External interrupts with an RC-delay noise filter circuit can be used to release Stop mode. Which interrupt you can use to release Stop mode in a given situation depends on the microcontroller's current internal operating mode. The external interrupts in the S3C84H5/F84H5 interrupt structure that can be used to release Stop mode are:

- External interrupts P1.0-P1.3 (INT0-INT3).

Please note the following conditions for Stop mode release:

- If you release Stop mode using an external interrupt, the current values in system and peripheral control registers are unchanged.
- If you use an external interrupt for Stop mode release, you can also program the duration of the oscillation stabilization interval. To do this, you must make the appropriate control and clock settings *before* entering Stop mode.
- When the Stop mode is released by external interrupt, the CLKCON.4 and CLKCON.3 bit-pair setting remains unchanged and the currently selected clock value is used.
- The external interrupt is serviced when the Stop mode release occurs. Following the IRET from the service routine, the instruction immediately following the one that initiated Stop mode is executed.

How to Enter into Stop Mode

There are two steps to enter into Stop mode:

1. Handling STOPCON register to appropriate value (10100101B).
2. Writing Stop instruction (keep the order).

IDLE MODE

Idle mode is invoked by the instruction IDLE (opcode 6FH). In idle mode, CPU operations are halted while some peripherals remain active. During idle mode, the internal clock signal is gated away from the CPU, but all peripherals timers remain active. Port pins retain the mode (input or output) they had at the time idle mode was entered.

There are two ways to release idle mode:

1. Execute a reset. All system and peripheral control registers are reset to their default values and the contents of all data registers are retained. The reset automatically selects the slow clock fxx/16 because CLKCON.4 and CLKCON.3 are cleared to '00B'. If interrupts are masked, a reset is the only way to release idle mode.
2. Activate any enabled interrupt, causing idle mode to be released. When you use an interrupt to release idle mode, the CLKCON.4 and CLKCON.3 register values remain unchanged, and the currently selected clock value is used. The interrupt is then serviced. When the return-from-interrupt (IRET) occurs, the instruction immediately following the one that initiated idle mode is executed.

9

I/O PORTS

OVERVIEW

The S3C84H5/F84H5 microcontroller has five bit-programmable I/O ports, P0-P3. This gives a total of 22 I/O pins. Each port can be flexibly configured to meet application design requirements. The CPU accesses ports by directly writing or reading port registers. No special I/O instructions are required.

Table 9-1 gives you a general overview of the S3C84H5/F84H5 I/O port functions.

Table 9-1. S3C84H5/F84H5 Port Configuration Overview

Port	Configuration Options
0	Bit programmable port; input or output mode selected by software; input or push-pull output. Software assignable pull-up resistor. Alternately, P0.0~P0.3 can be used as AD0~AD3.
1	Bit programmable port; input or output mode selected by software; input or push-pull output. Software assignable pull-up resistor. Alternatively, P1.0~P1.5 can be used as INT0~INT3, TAOUT, TACK, TACAP, T1OUT0, T1CK1, T1CAP1, AD5, AD6.
2	Bit programmable port; input or output mode selected by software; input or push-pull output. Software assignable pull-up. Alternately, P2.0~P2.7 can be used ADC4, ADC7, SI, T1CAP0, T1OUT1, T1CK0, SO, SCK, RxD, TxD, TBPWM, PWM
3	Bit programmable port; input or output mode selected by software; input or push-pull, N-channel open-drain output. Software assignable pull-up..

NOTE: In debug mode, you have to include three extra commands in initial routine to operate Ports correctly. If you omit these commands, Port do not operate correctly. (Refer to page 9-14)
After you have finished your program and before assembling, you have to remove these three commands.

```
.ORG 100H
SB1                ; Extra command only for debugging
LD    0F7H,#5FH   ; Extra command only for debugging
SB0                ; Extra Command Only for Debugging
```

PORT DATA REGISTERS

Table 9-2 gives you an overview of the register locations of all seven S3C84H5/F84H5 I/O port data registers. Data registers for ports 0, 1, 2, and 3 have the general format shown in Table 9-2.

Table 9-2. Port Data Register Summary

Register Name	Mnemonic	Decimal	Hex	Location	R/W
Port 0 data register	P0	224	E0H	Set 1, Bank 0	R/W
Port 1 data register	P1	225	E1H	Set 1, Bank 0	R/W
Port 2 data register	P2	226	E2H	Set 1, Bank 0	R/W
Port 3 data register	P3	227	E3H	Set 1, Bank 0	R/W

PORT 0

Port 0 is an 4-bit I/O port that you can use two ways:

- General-purpose digital I/O
- Alternative function: AD0~AD3

Port 0 is accessed directly by writing or reading the port 0 data register, P0 at location E0H in set 1, bank 0.

Port 0 Control Register (P0CON)

Port 0 has one 8-bit control registers: P0CON for P0.0–P0.3. A reset clears the P0CON registers to “00H”, configuring all pins to input modes. You use control registers settings to select input or output mode (push-pull) and enable the alternative functions.

When programming the port, please remember that any alternative peripheral I/O function you configure using the port 0 control registers must also be enabled in the associated peripheral module.

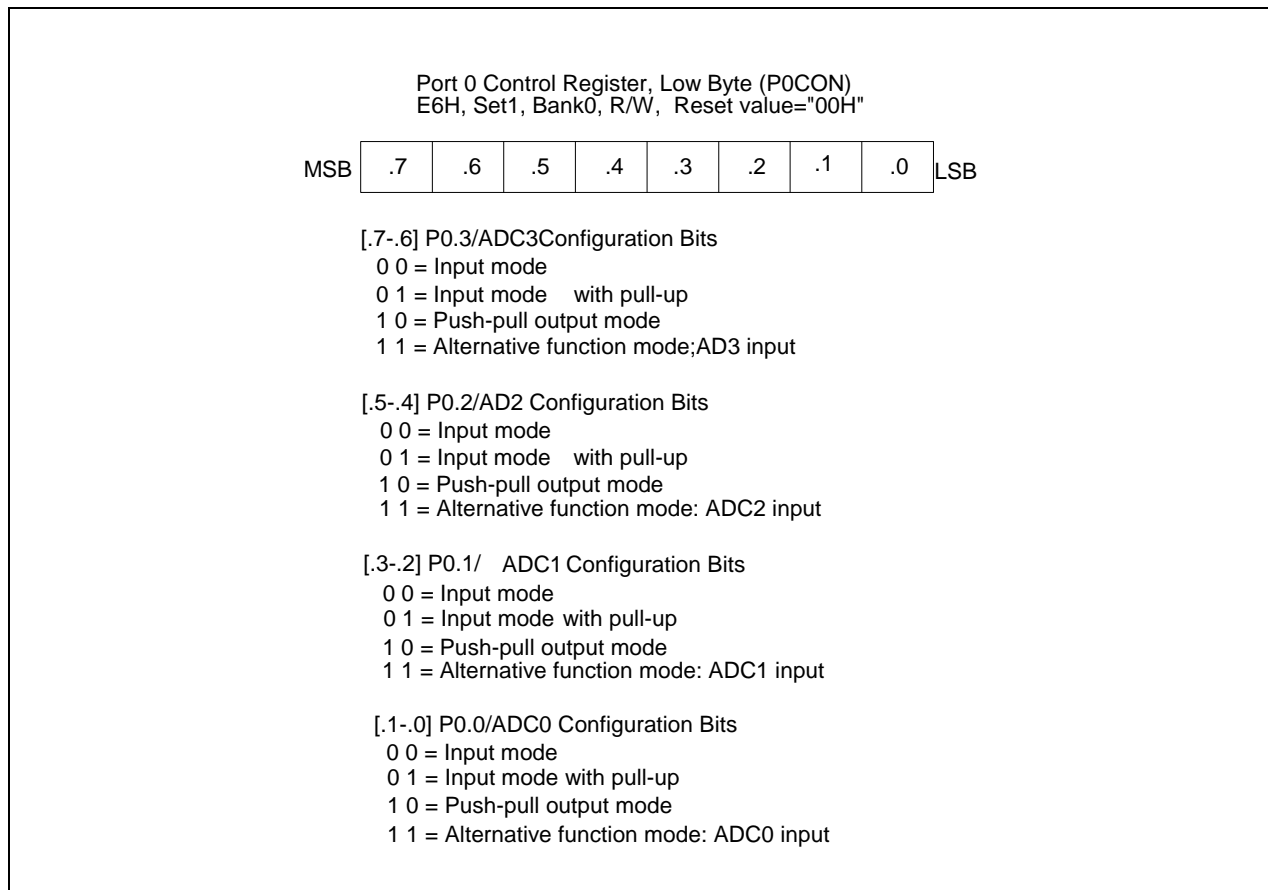


Figure 9-1. Port 0 Low Byte Control Register (P0CON)

PORT 1

Port 1 is a 6-bit I/O port with individually configurable pins that you can use two ways:

- General-purpose digital I/O
- Alternative function: INT0~INT3, TAOUT, TACK, TACAP, T1OUT0,T1CK1,T1CAP1,AD5,AD6

Port 1 is accessed directly by writing or reading the port 1 data register, P1 at location E1H in set 1, bank 0.

Port 1 Control Register (P1CONH, P1CONL)

Port 1 has two 6-bit control registers: P1CONH for P1.4–P1.5 and P1CONL for P1.0–P1.3. A reset clears the P1CONH and P1CONL registers to “00H”, configuring all pins to input modes. You use control registers settings to select input or output mode (push-pull) and enable the alternative functions.

When programming the port, please remember that any alternative peripheral I/O function you configure using the port 1 control registers must also be enabled in the associated peripheral module.

Port 1 Interrupt Enable, Pending, and Edge Selection Registers (P1INT,P1INTPND)

To process external interrupts at the port 1 pins, three additional control registers are provided: the port 1 interrupt enable register P1INT (EAH, SET1 BANK 0), the port 1 interrupt pending bits P1INTPND (EBH, SET1 BANK 0).

The port 1 interrupt pending register bits lets you check for interrupt pending conditions and clear the pending condition when the interrupt service routine has been initiated. The application program detects interrupt requests by polling the P1INTPND1.3-0 register at regular intervals.

When the interrupt enable bit of any port 1 pin is "1", a rising or falling edge at that pin will generate an interrupt request. The corresponding P1INTPND1 bit is then automatically set to "1" and the IRQ level goes low to signal the CPU that an interrupt request is waiting. When the CPU acknowledges the interrupt request, application software must clear the pending condition by writing a "0" to the corresponding P1INTPND1 bit.

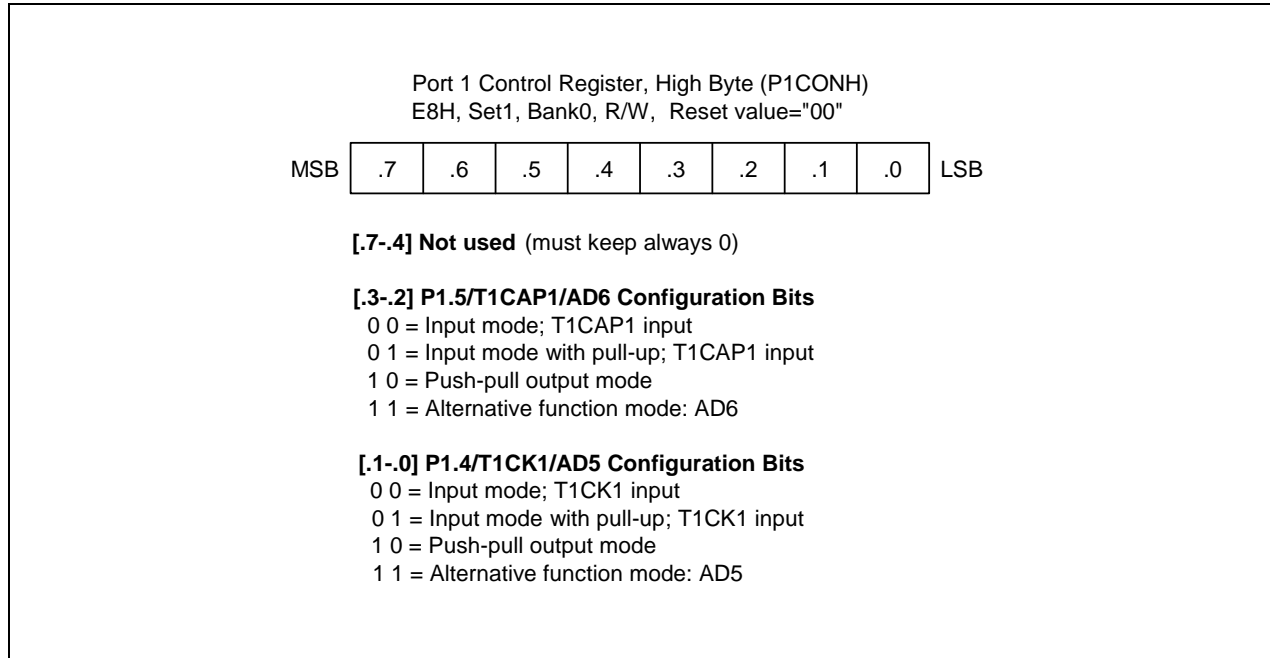


Figure 9-2. Port 1 High-Byte Control Register (P1CONH)

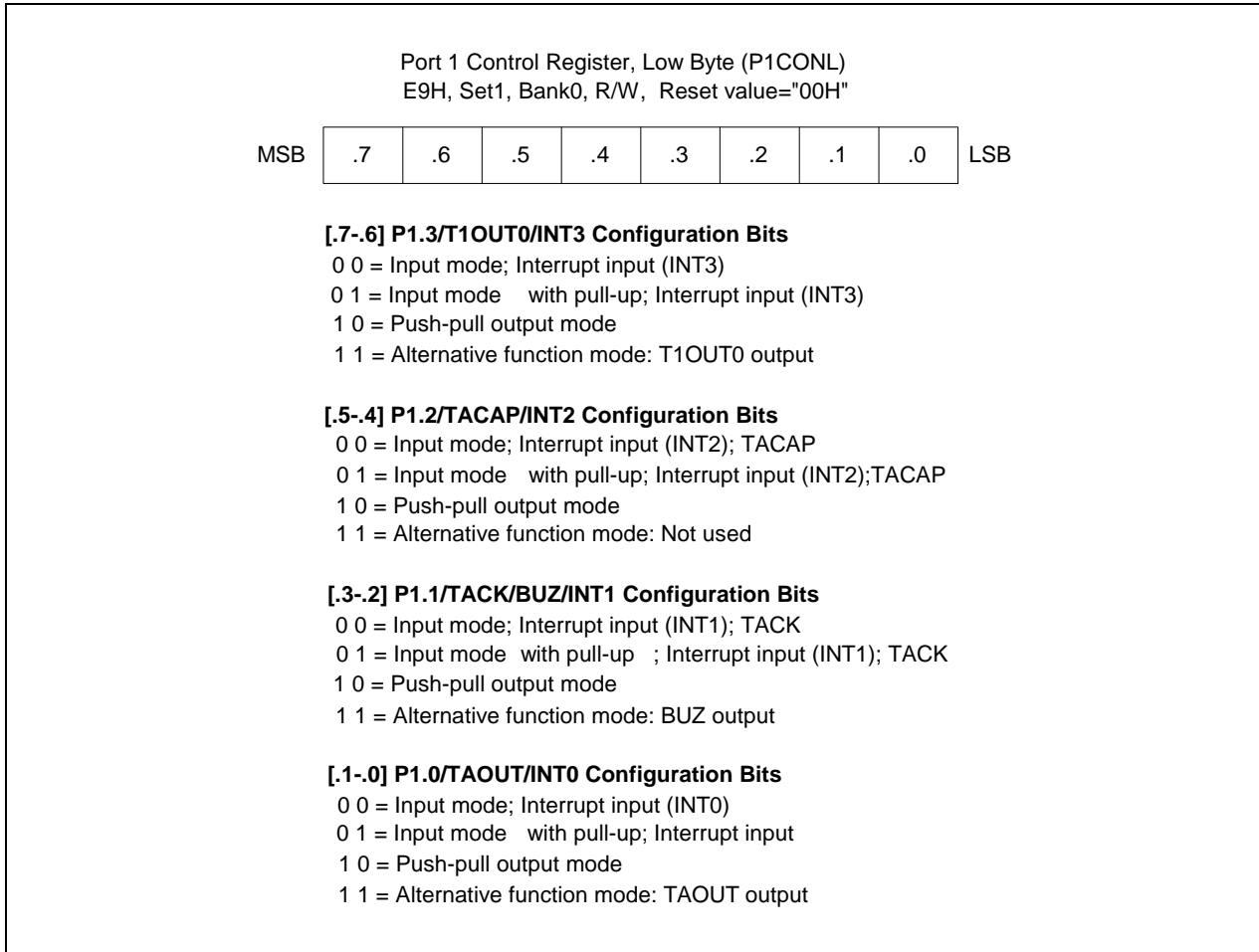


Figure 9-3. Port 1 Low-Byte Control Register (P1CONL)

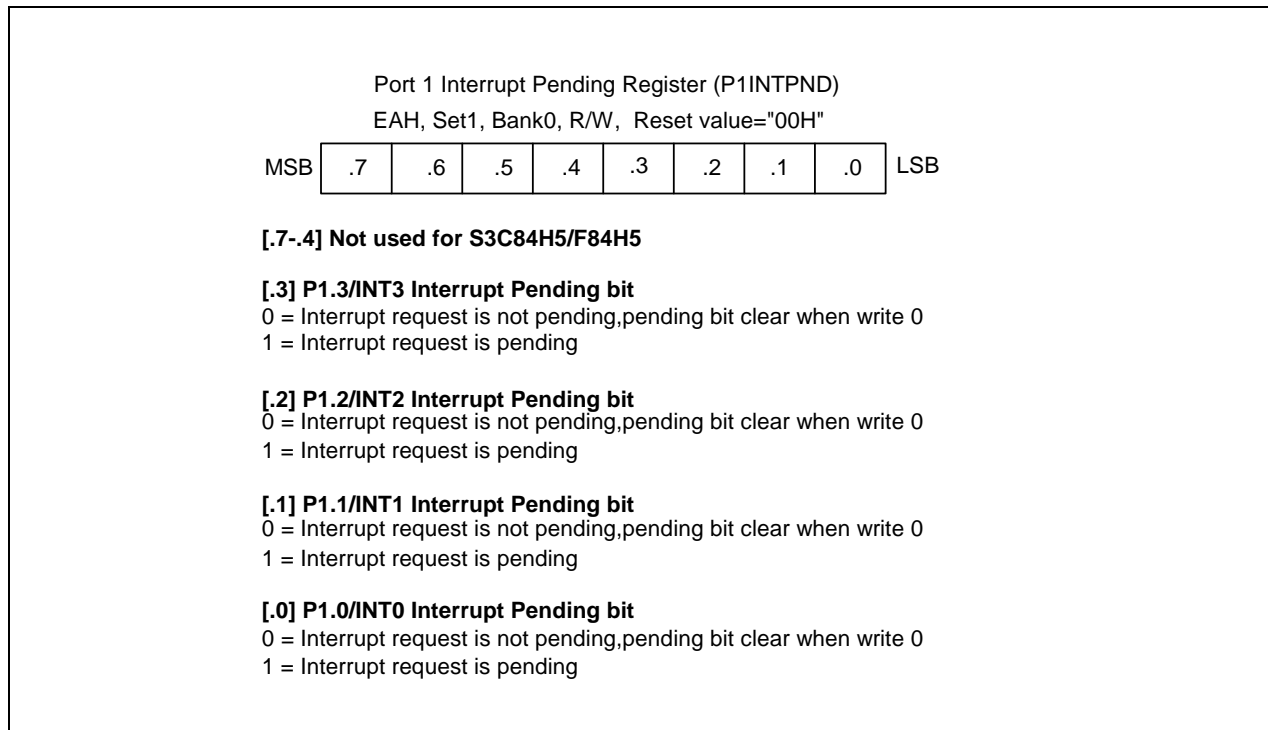


Figure 9-4. Port 1 Interrupt Pending Register (P1INTPND)

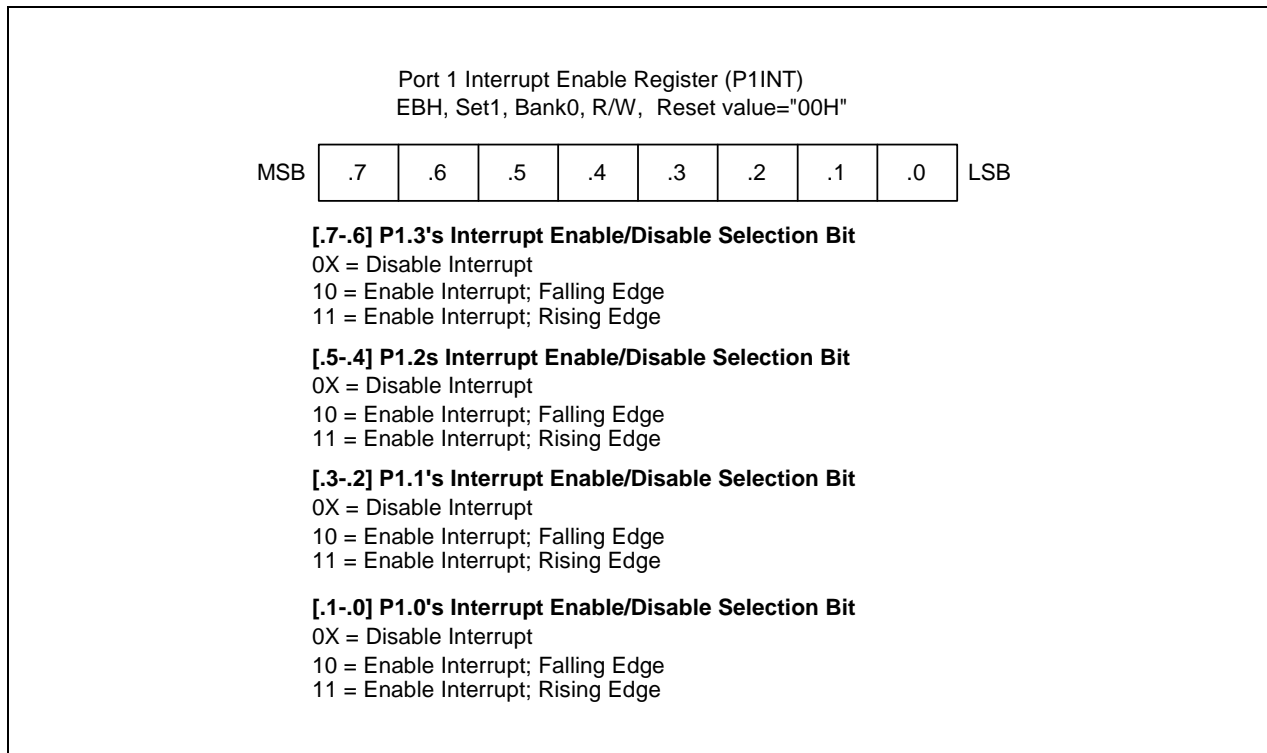


Figure 9-5. Port 1 Interrupt Enable Register (P1INT)

PORT 2

Port 2 is an 8-bit I/O port with individually configurable pins. Port 2 pins are accessed directly by writing or reading the port 2 data register, P2 at location E2H in set 1, bank 0. P2.0–P2.7 can serve as digital inputs, outputs (push pull) or you can configure the following alternative functions:

- General-purpose digital I/O
- Alternative function: ADC4,ADC7,SI, T1CAP0,T1OUT1,T1CK0,TBPWM,PWM

Port 2 Control Register (P2CONH, P2CONL)

Port 2 has two 8-bit control registers: P2CONH for P2.4–P2.7 and P2CONL for P2.0–P2.3. A reset clears the P2CONH and P2CONL registers to "00H", configuring all pins to input mode. You use control registers settings to select input or output mode (push-pull) and enable the alternative functions.

When programming the port, please remember that any alternative peripheral I/O function you configure using the port 2 control registers must also be enabled in the associated peripheral module.

Port 2 Pull-up control Registers (P2PUR)

Using the port 2 pull-up control register, P2PUR (FA, SET1,BANK0), you can configure pull-up resistors to individual port 0 pins.

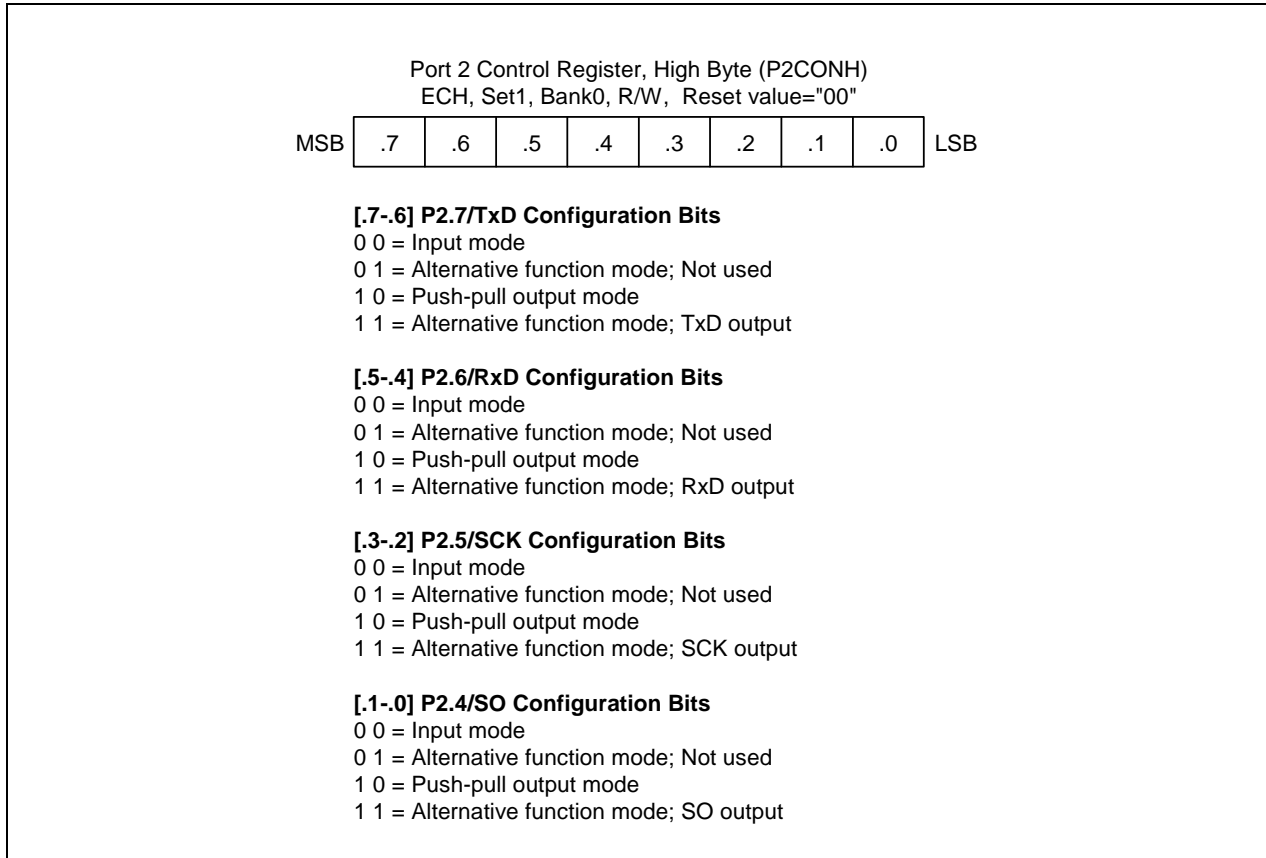


Figure 9-6. Port 2 High-Byte Control Register (P2CONH)

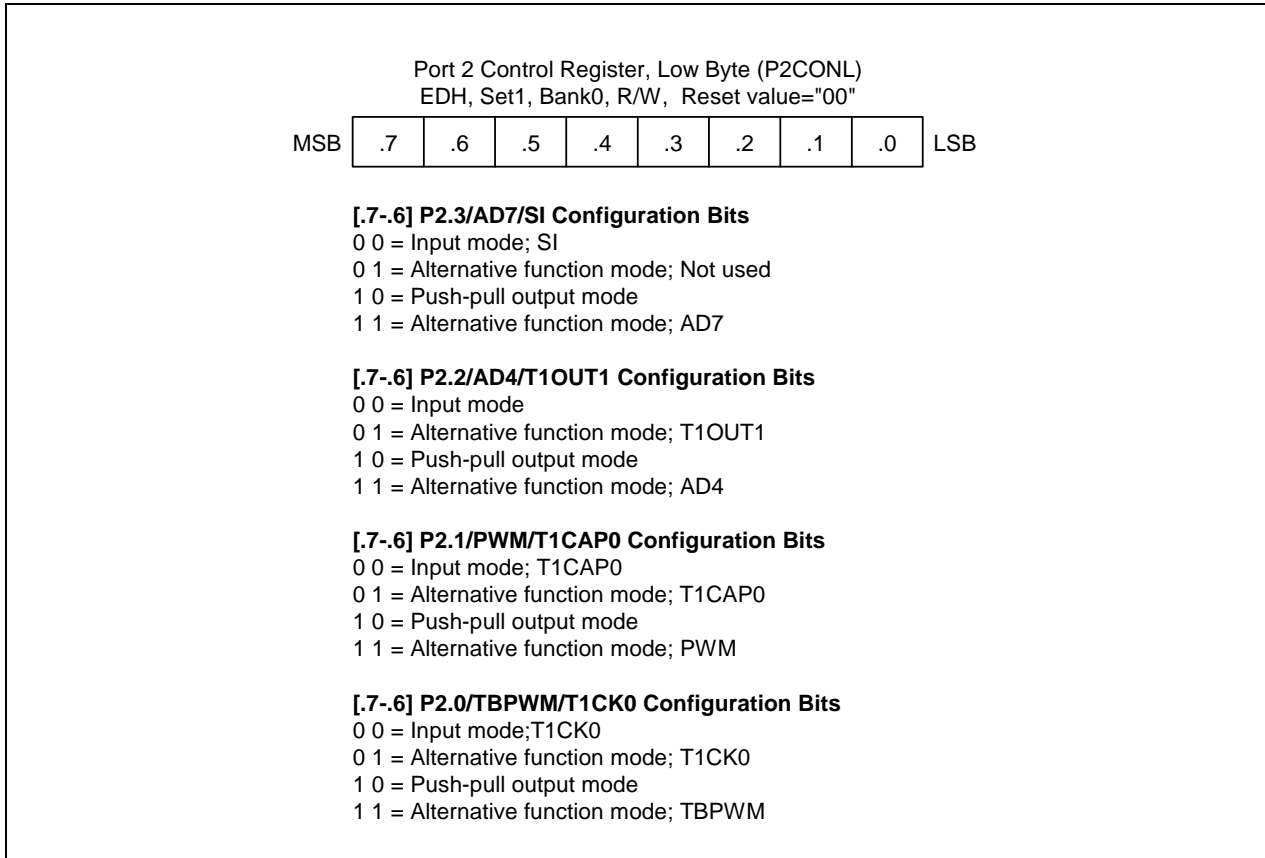


Figure 9-7. Port 2 Low-Byte Control Register (P2CONL)

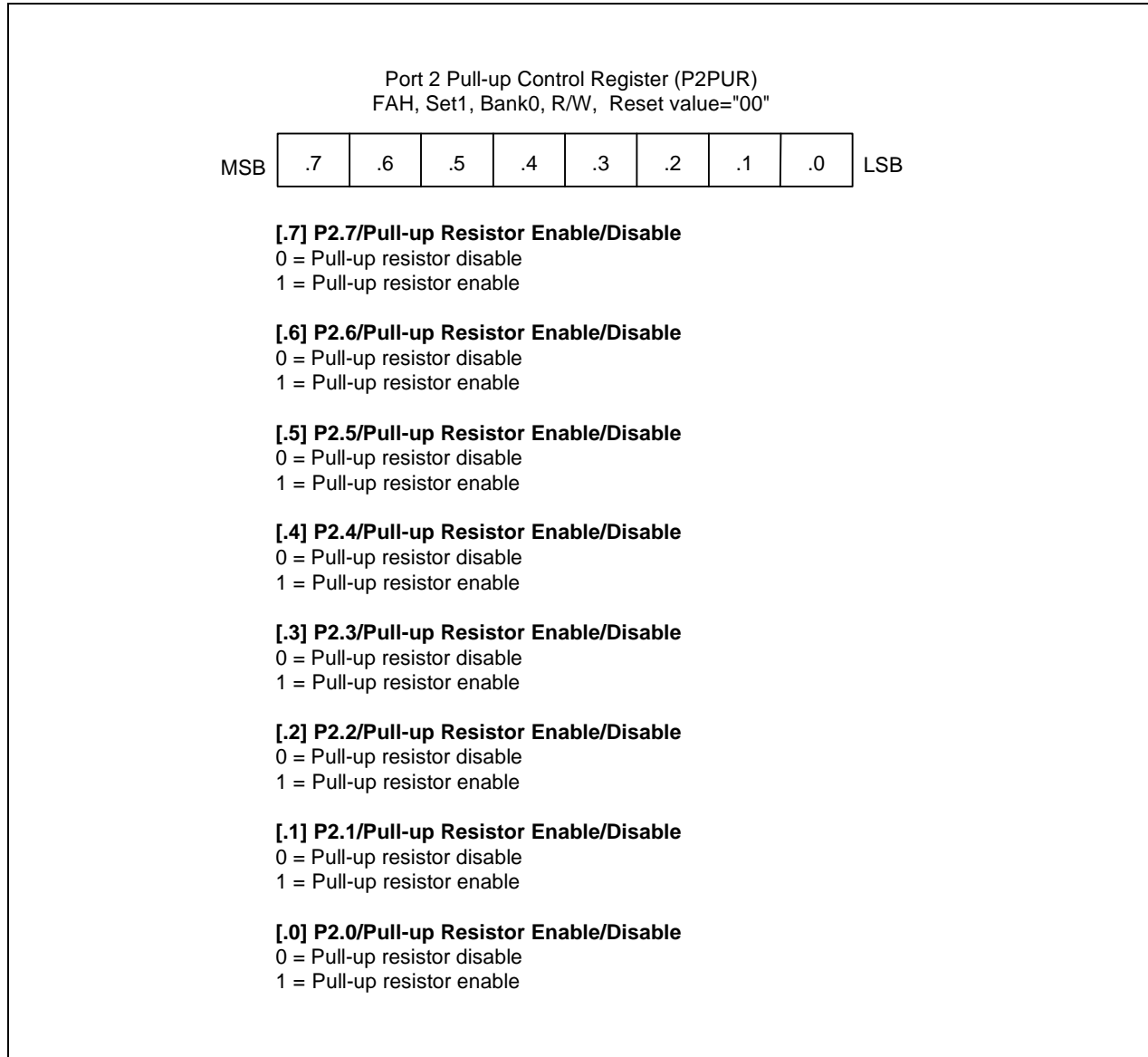


Figure 9-8. Port 2 Pull-up Control Register (P2PUR)

PORT 3

Port 3 is an 8-bit I/O port that can be used for general-purpose digital I/O. The pins are accessed directly by writing or reading the port 3 data register, P3 at location E3H in set 1, bank 0. P3.0–P3.3 can serve as inputs, outputs (push pull).

Port 3 Control Register (P3CONL)

Port 3 has two 8-bit control registers: P3CONH for P3.4–P3.7 and P3CONL for P3.0–P3.3. A reset clears the P3CONH and P3CONL registers to "00H", configuring all pins to input mode. You use control registers settings to select input or output mode (push-pull, Open-drain) and enable the alternative functions.

When programming the port, please remember that any alternative peripheral I/O function you configure using the port 3 control registers must also be enabled in the associated peripheral module.

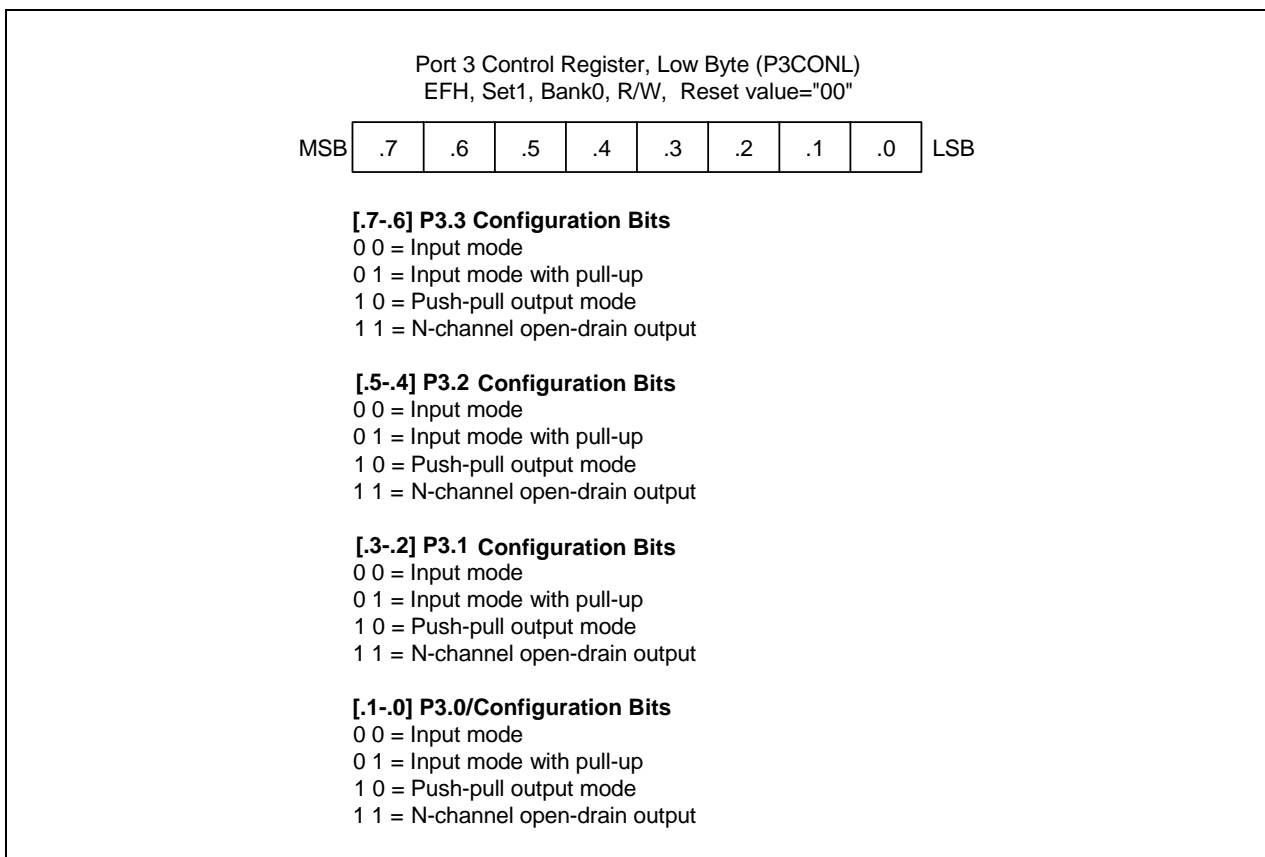


Figure 9-9. Port 3 Low-Byte Control Register (P3CONL)

 **Programming Tip — Using the Timer A**

```

        ORG        0000h

        VECTOR    0C0h,TAMC_INT
        VECTOR    0C2h,TAOV_INT

        ORG        0100h

INITIAL:
        LD        SYM,#00h           ; Disable Global/Fast interrupt → SYM
        LD        IMR,#00000010b    ; Enable IRQ1 interrupt
        LD        SPH,#00000000b    ; Set stack area
        LD        SPL,#00000000b
        LD        BTCON,#10100011b ; Disable watch-dog

        LD P1CONL,#0ABH             ; Enable TAOUT output
        SB1
        LD TADATA,#80h
        LD TACON,#01001010b        ; Match interrupt enable
        ;                          6.55 ms duration (10 MHz x'tal)
        SB0

        EI

MAIN:
        .
        .
        MAIN ROUTINE
        .
        .

        JR        T,MAIN

TAMC_INT:
        .
        .
        Interrupt service routine
        .
        .
        IRET

TAOV_INT:
        .
        Interrupt service routine
        .
        IRET

        .END

```

 **PROGRAMMING TIP — Using Ports**

```

        ORG        0100h

INITIAL:
        SB1
        LD        0F7H,#5FH          ; Extra command only for debugging(1)
        SB0          ; Extra command only for debugging(1)
                                ; Extra command only for debugging(1)

        DI
        LD        SPL,#00000000b
        LD        BTCON,#10100011b  ; Disable Watch-dog
        LD        CLKCON,#18H

        LD        P0CON,#0AAH       ; PORT0 PUSH-PULL OUTPUT
        LD        P1CONH,#0AAH      ; PORT1 PUSH-PULL OUTPUT
        LD        P1CONL,#0AAH      ; PORT1 PUSH-PULL OUTPUT
        LD        P2CONH,#0AAH      ; PORT2 PUSH-PULL OUTPUT
        LD        P2CONL,#0AAH      ; PORT2 PUSH-PULL OUTPUT
        LD        P3CONL,#0AAH      ; PORT3 PUSH-PULL OUTPUT

MAIN:
        .
        .
        .
        XOR       P0,#0FH
        XOR       P1,#03FH
        XOR       P2,#0FFH
        XOR       P3,#0FH
        .
        .
        .

        JR        T,MAIN

        .END

```

NOTE: In debug mode, you have to include three extra commands in initial routine to operate Ports correctly. If you omit these commands, Port do not operate correctly. After you have finished your program and before assembling, you have to remove these three commands.

10

BASIC TIMER

OVERVIEW

BASIC TIMER (BT)

You can use the basic timer (BT) in two different ways:

- As a watchdog timer to provide an automatic reset mechanism in the event of a system malfunction.
- To signal the end of the required oscillation stabilization interval after a reset or a Stop mode release.

The functional components of the basic timer block are:

- Clock frequency divider (f_{xx} divided by 4096, 1024 or 128) with multiplexer
- 8-bit basic timer counter, BTCNT (set 1, bank 0, FDH, read-only)
- Basic timer control register, BTCON (set 1, D3H, read/write)

BASIC TIMER CONTROL REGISTER (BTCON)

The basic timer control register, BTCON, is used to select the input clock frequency, to clear the basic timer counter and frequency dividers, and to enable or disable the watchdog timer function. It is located in set 1, address D3H, and is read/write addressable using register addressing mode.

A reset clears BTCON to '00H'. This enables the watchdog function and selects a basic timer clock frequency of $f_{xx}/4096$. To disable the watchdog function, write the signature code '1010B' to the basic timer register control bits BTCON.7–BTCON.4.

The 8-bit basic timer counter, BTCNT (set 1, bank 0, FDH), can be cleared at any time during normal operation by writing a "1" to BTCON.1. To clear the frequency dividers, write a "1" to BTCON.0.

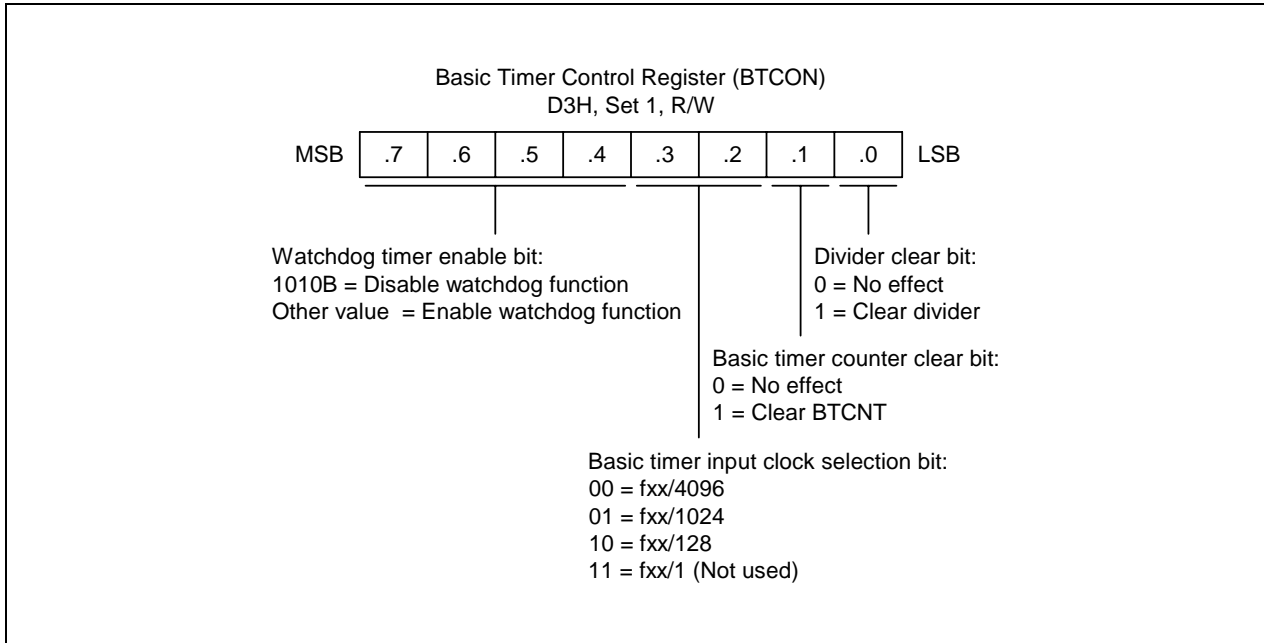


Figure 10-1. Basic Timer Control Register (BTCON)

BASIC TIMER FUNCTION DESCRIPTION

Watchdog Timer Function

You can program the basic timer overflow signal (BTOVF) to generate a reset by setting BTCON.7–BTCON.4 to any value other than "1010B". (The "1010B" value disables the watchdog function.) A reset clears BTCON to "00H", automatically enabling the watchdog timer function. A reset also selects the CPU clock (as determined by the current CLKCON register setting), divided by 4096, as the BT clock.

The CPU is reset whenever a basic timer counter overflow occurs. During normal operation, the application program must prevent the overflow, and the accompanying reset operation, from occurring. To do this, the BTCNT value must be cleared (by writing a "1" to BTCON.1) at regular intervals.

If a system malfunction occurs due to circuit noise or some other error condition, the BT counter clear operation will not be executed and a basic timer overflow will occur, initiating a reset. In other words, during the normal operation, the basic timer overflow loop (a bit 7 overflow of the 8-bit basic timer counter, BTCNT) is always broken by a BTCNT clear instruction. If a malfunction does occur, a reset is triggered automatically.

Oscillation Stabilization Interval Timer Function

You can also use the basic timer to program a specific oscillation stabilization interval following a reset or when Stop mode has been released by an external interrupt.

In Stop mode, whenever a reset or an external interrupt occurs, the oscillator starts. The BTCNT value then starts increasing at the rate of $f_{xx}/4096$ (for reset), or at the rate of the preset clock source (for an external interrupt). When BTCNT.4 overflows, a signal is generated to indicate that the stabilization interval has elapsed and to gate the clock signal off to the CPU so that it can resume normal operation.

In summary, the following events occur when stop mode is released:

1. During stop mode, a power-on reset or an interrupt occurs to trigger the Stop mode release and oscillation starts.
2. If a power-on reset occurred, the basic timer counter will increase at the rate of $f_{xx}/4096$. If an external interrupt is used to release stop mode, the BTCNT value increases at the rate of the preset clock source.
3. Clock oscillation stabilization interval begins and continues until bit 4 of the basic timer counter overflows.
4. When a BTCNT.4 overflow occurs, normal CPU operation resumes.

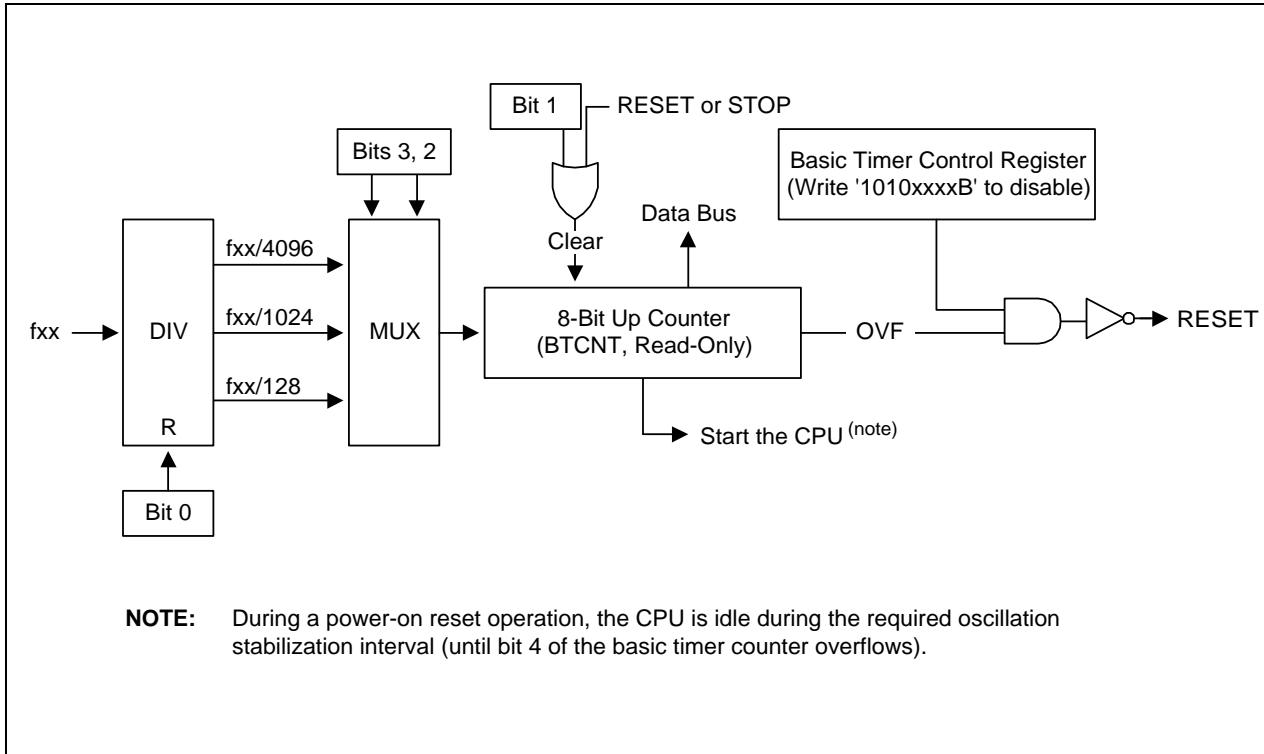


Figure 10-2. Basic Timer Block Diagram

11

8-BIT TIMER A/B

8-BIT TIMER A

OVERVIEW

The 8-bit timer A is an 8-bit general-purpose timer/counter. Timer A has three operating modes, you can select one of them using the appropriate TACON setting:

- Interval timer mode (Toggle output at TAOUT pin)
- Capture input mode with a rising or falling edge trigger at the TACAP pin
- PWM mode (TAPWM)

Timer A has the following functional components:

- Clock frequency divider (f_{clk} divided by 1024, 256, or 64) with multiplexer
- External clock input pin (TACK)
- 8-bit counter (TACNT), 8-bit comparator, and 8-bit reference data register (TADATA)
- I/O pins for capture input (TACAP) or PWM or match output (TAOUT)
- Timer A overflow interrupt (IRQ1, vector C2H) and match/capture interrupt (IRQ1, vector C0H) generation
- Timer A control register, TACON (set 1, bank1, E1H, read/write)

FUNCTION DESCRIPTION

Timer A Interrupts (IRQ1, Vectors C0H and C2H)

The timer A module can generate two interrupts: the timer A overflow interrupt (TAOVF), and the timer A match/capture interrupt (TAINT). TAOVF is interrupt level IRQ1, vector C2H. TAINT also belongs to interrupt level IRQ1, but is assigned the separate vector address, C0H.

Timer A overflow interrupt pending condition is automatically cleared by hardware when it has been serviced. Timer A match/capture interrupt, TAINT pending condition is also cleared by hardware when it has been serviced.

Interval Timer Function

The timer A module can generate an interrupt: the timer A match interrupt (TAINT). TAINT belongs to interrupt level IRQ1, and is assigned the separate vector address, C0H.

When the timer A match interrupt occurs and is serviced by the CPU, the pending condition is cleared automatically by hardware.

In interval timer mode, a match signal is generated and TAOUT is toggled when the counter value is identical to the value written to the timer A reference data register, TADATA. The match signal generates a timer A match interrupt (TAINT, vector C0H) and clears the counter.

If, for example, you write the value 10H to TADATA and 0AH to TACON, the counter will increment until it reaches 10H. At this point, the Timer A interrupt request is generated, the counter value is reset, and counting resumes.

Pulse Width Modulation Mode

Pulse width modulation (PWM) mode lets you program the width (duration) of the pulse that is output at the TAOUT pin. As in interval timer mode, a match signal is generated when the counter value is identical to the value written to the Timer A data register, TADATA. In PWM mode, however, the match signal does not clear the counter. Instead, it runs continuously, overflowing at FFH, and then continues incrementing from 00H.

Although you can use the match signal to generate a timer A overflow interrupt, interrupts are not typically used in PWM-type applications. Instead, the pulse at the TAOUT pin is held to Low level as long as the reference data value is *less than or equal to* (\leq) the counter value and then the pulse is held to High level for as long as the data value is *greater than* ($>$) the counter value. One pulse width is equal to $t_{CLK} \cdot 256$.

Capture Mode

In capture mode, a signal edge that is detected at the TACAP pin opens a gate and loads the current counter value into the Timer A data register. You can select rising or falling edges to trigger this operation.

Timer A also gives you capture-input source: the signal edge at the TACAP pin. You select the capture input by setting the value of the Timer A capture input selection bit in the port 0 control register, P0CONH, (set 1, bank 0, E6H). When P0CONH.1-.0 is '00' or '01', the TACAP input or normal input is selected. When P0CONH.1-.0 is set to 1X, normal push-pull output is selected.

Both kinds of timer A interrupts can be used in capture mode: the timer A overflow interrupt is generated whenever a counter overflow occurs; the timer A match/capture interrupt is generated whenever the counter value is loaded into the Timer A data register.

By reading the captured data value in TADATA, and assuming a specific value for the timer A clock frequency, you can calculate the pulse width (duration) of the signal that is being input at the TACAP pin.

TIMER A CONTROL REGISTER (TACON)

You use the timer A control register, TACON, to:

- Select the timer A operating mode (interval timer, capture mode and PWM mode)
- Select the timer A input clock frequency
- Clear the timer A counter, TACNT
- Enable the timer A overflow interrupt or timer A match/capture interrupt
- Clear timer A match/capture interrupt pending conditions

TACON is located in set 1, Bank 1 at address E1H, and is read/write addressable using Register addressing mode. A reset clears TACON to '00H'. This sets timer A to normal interval timer mode, selects an input clock frequency of $fx/1024$, and disables all timer A interrupts. You can clear the timer A counter at any time during normal operation by writing a "1" to TACON.3.

The timer A overflow interrupt (TAOVF) is interrupt level IRQ1 and has the vector address C2H. When a timer A overflow interrupt occurs and is serviced by the CPU, the pending condition is cleared automatically by hardware.

To enable the timer A match/capture interrupt (IRQ1, vector C0H), you must write TACON.1 to "1". To generate the exact time interval, you should write TACON.3 and .0 to "1", which cleared counter and interrupt pending bit. When interrupt service routine is served, the pending condition must be cleared by software by writing a '0' to the interrupt pending bit (TINTPND.0 or TINTPND.1).

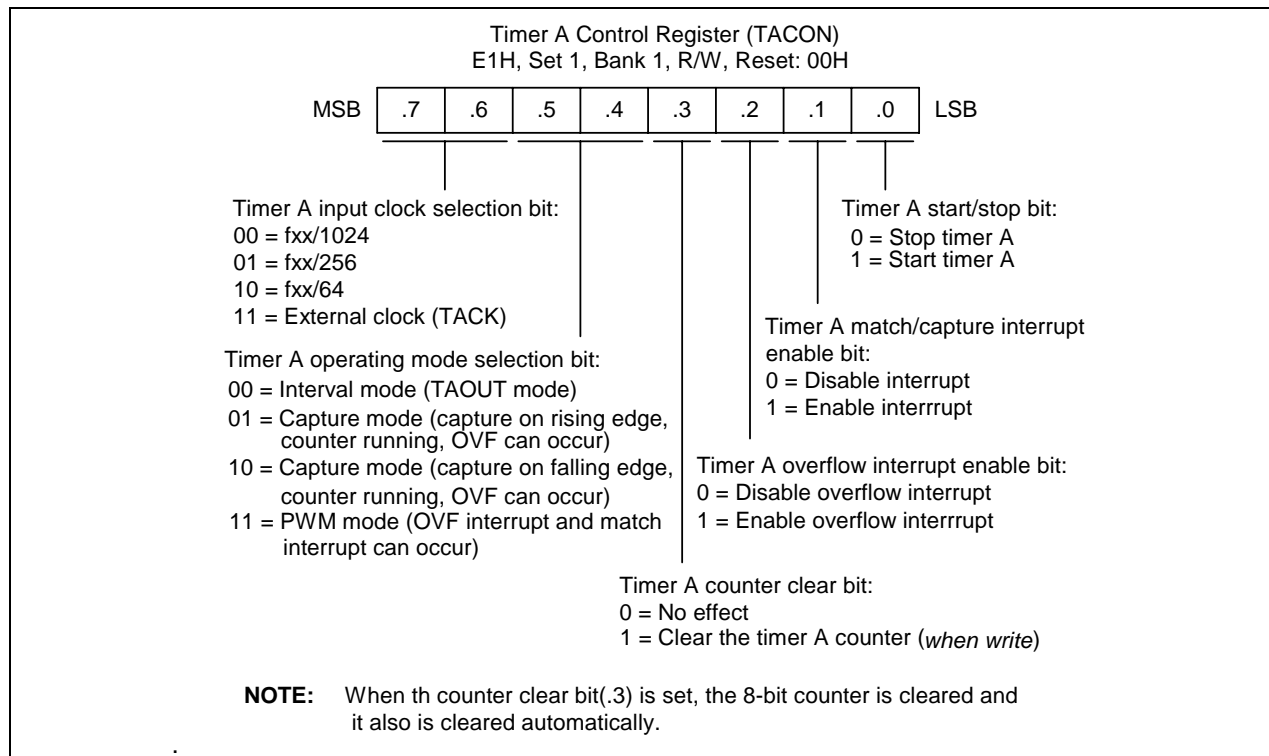


Figure 11-1. Timer A Control Register (TACON)

BLOCK DIAGRAM

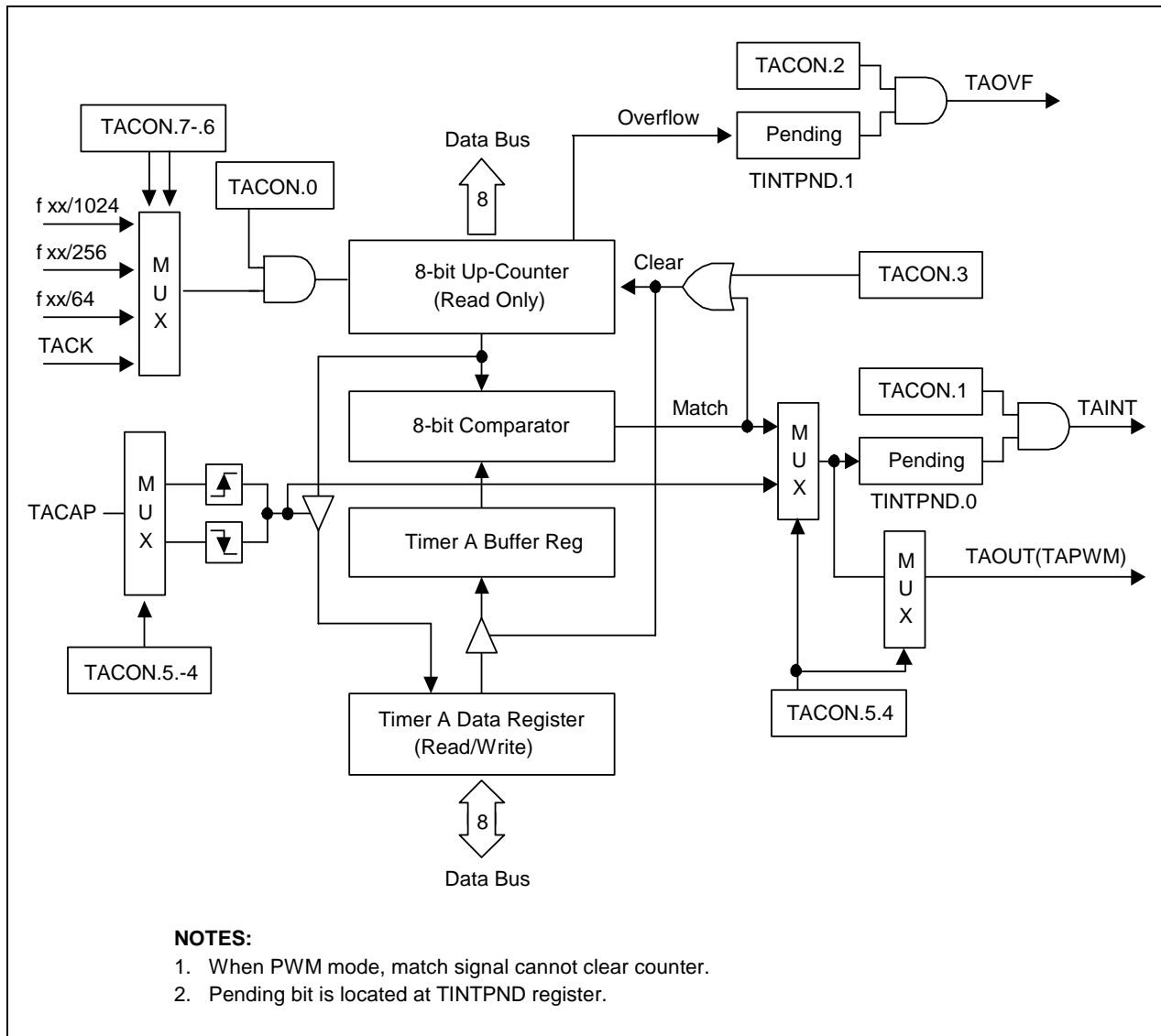


Figure 11-2. Timer A Functional Block Diagram

8-BIT TIMER B

OVERVIEW

The S3C84H5/F84H5 micro-controller has an 8-bit timer called timer B. Timer B, which can be used to generate the carrier frequency of a remote controller signal. Also, it can be used as the programmable buzz signal generator that makes a sound with a various frequency from 200Hz to 20KHz. These various frequencies can be used to generate a melody sound.

Timer B has two functions:

- As a normal interval timer, generating a timer B interrupt at programmed time intervals.
- To generate a programmable carrier pulse for a remote control signal at P1.0.

BLOCK DIAGRAM

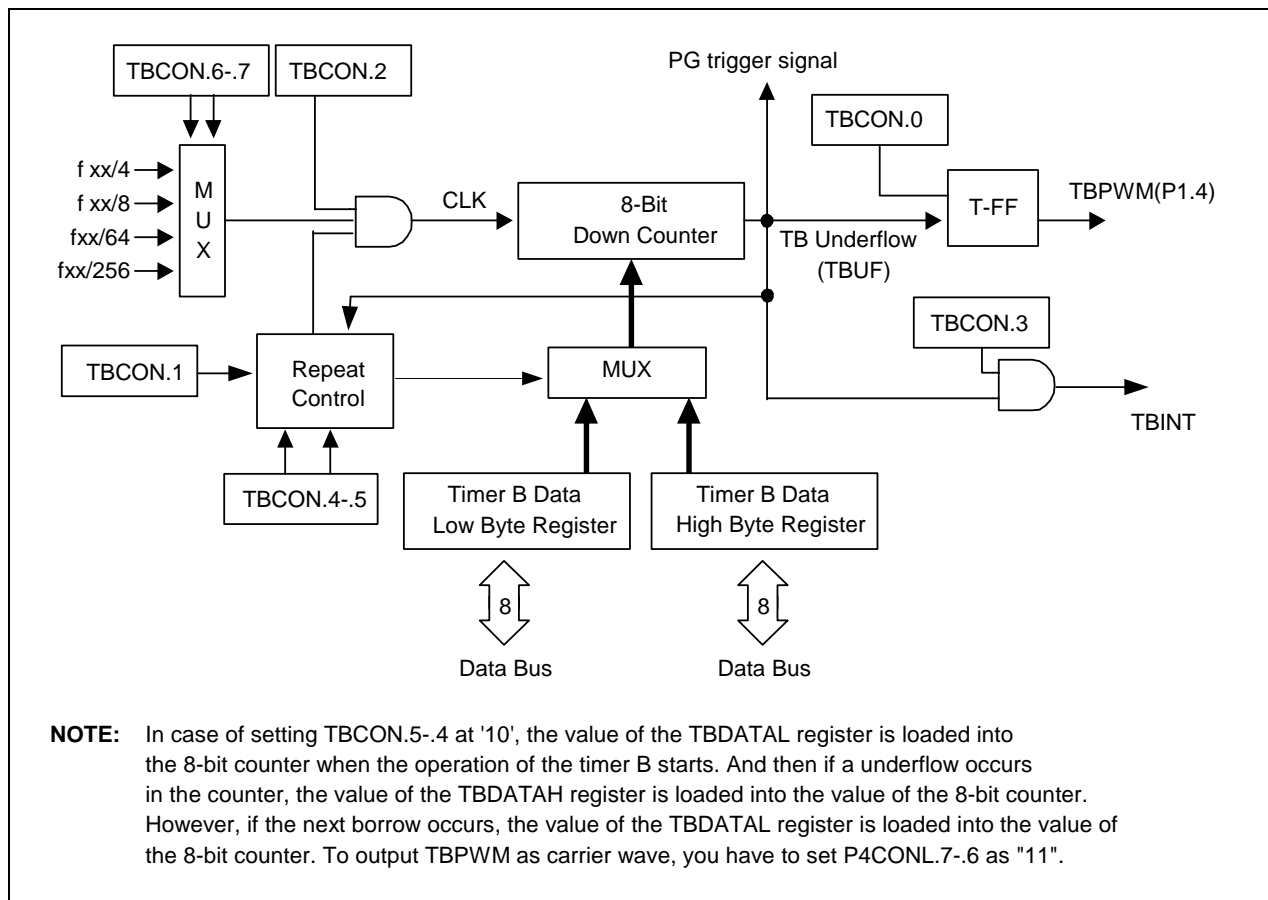


Figure 11-3. Timer B Functional Block Diagram

TIMER B CONTROL REGISTER (TBCON)

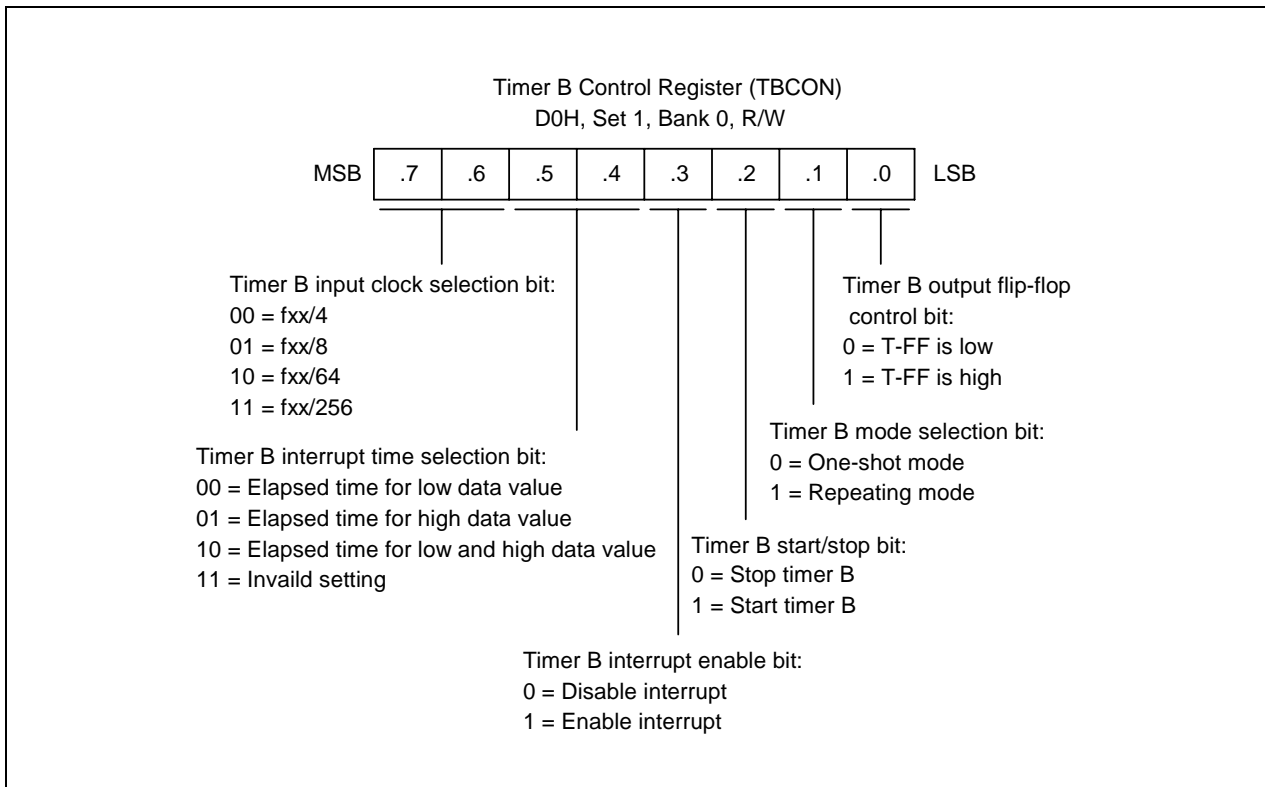


Figure 11-4. Timer B Control Register (TBCON)

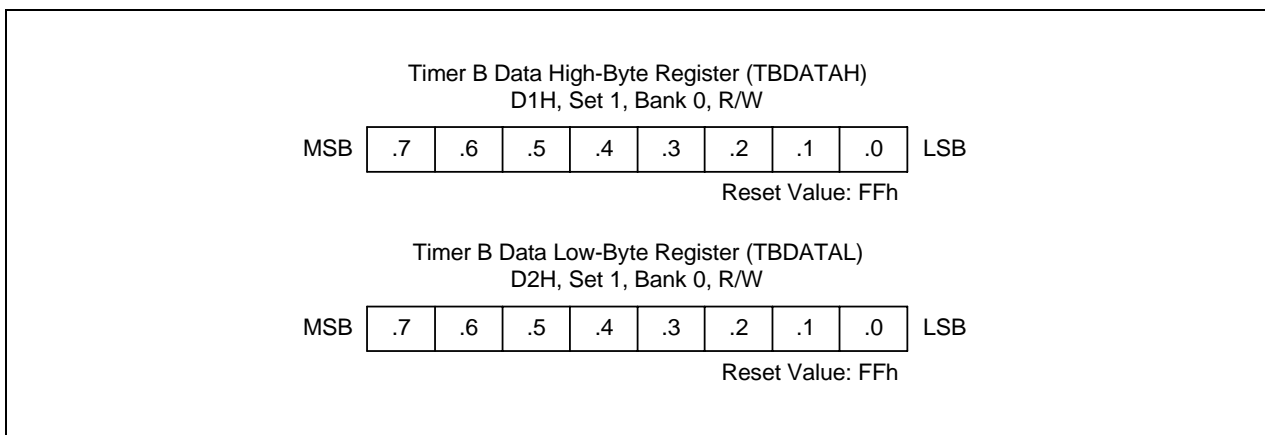
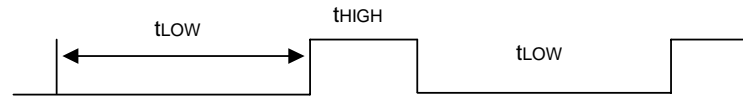


Figure 11-5. Timer B Data Registers (TBDATAH, TBDATAL)

TIMER B PULSE WIDTH CALCULATIONS



To generate the above repeated waveform consisted of low period time, t_{LOW} , and high period time, t_{HIGH} .

When T-FF = 0,

$$t_{LOW} = (TBDATAL + 1) \times 1/f_x, 0H < TBDATAL < 100H, \text{ where } f_x = \text{The selected clock.}$$

$$t_{HIGH} = (TBDATAH + 1) \times 1/f_x, 0H < TBDATAH < 100H, \text{ where } f_x = \text{The selected clock.}$$

When T-FF = 1,

$$t_{LOW} = (TBDATAH + 1) \times 1/f_x, 0H < TBDATAH < 100H, \text{ where } f_x = \text{The selected clock.}$$

$$t_{HIGH} = (TBDATAL + 1) \times 1/f_x, 0H < TBDATAL < 100H, \text{ where } f_x = \text{The selected clock.}$$

To make $t_{LOW} = 24 \mu s$ and $t_{HIGH} = 15 \mu s$. $f_{OSC} = 4 \text{ MHz}$, $f_x = 4 \text{ MHz}/4 = 1 \text{ MHz}$

When T-FF = 0,

$$t_{LOW} = 24 \mu s = (TBDATAL + 1) / f_x = (TBDATAL + 1) \times 1 \mu s, TBDATAL = 23.$$

$$t_{HIGH} = 15 \mu s = (TBDATAH + 1) / f_x = (TBDATAH + 1) \times 1 \mu s, TBDATAH = 14.$$

When T-FF = 1,

$$t_{HIGH} = 15 \mu s = (TBDATAL + 1) / f_x = (TBDATAL + 1) \times 1 \mu s, TBDATAL = 14.$$

$$t_{LOW} = 24 \mu s = (TBDATAH + 1) / f_x = (TBDATAH + 1) \times 1 \mu s, TBDATAH = 23.$$

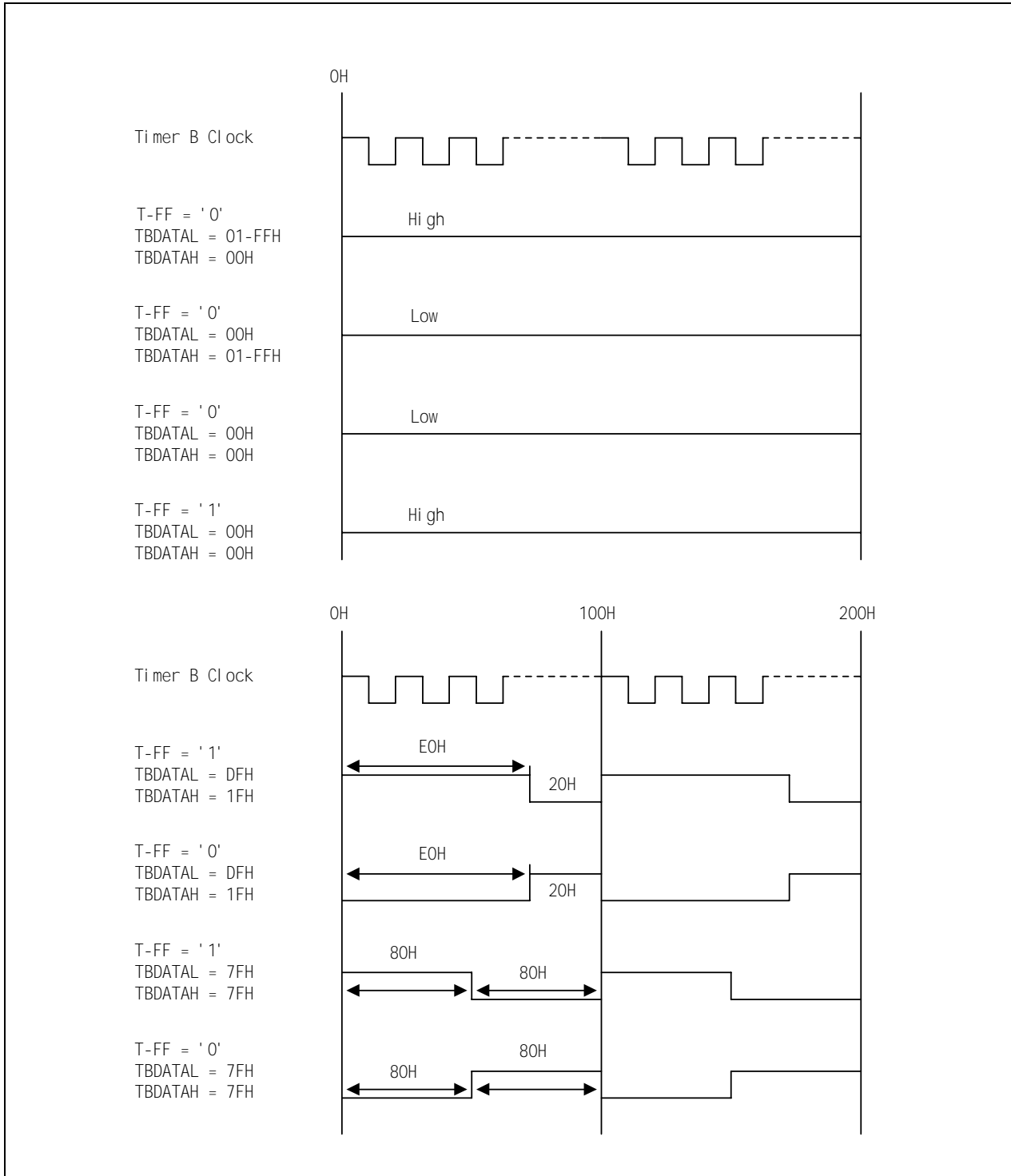
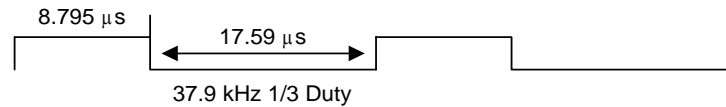


Figure 11-6. Timer B Output Flip Flop Waveforms in Repeat Mode

 **PROGRAMMING TIP — To generate 38 kHz, 1/3duty signal through P2.0**

This example sets Timer B to the repeat mode, sets the oscillation frequency as the Timer B clock source, and TBDATAH and TBDATAL to make a 38 kHz, 1/3 Duty carrier frequency. The program parameters are:



- Timer B is used in repeat mode
- Oscillation frequency is 16 MHz (0.0625 μ s), $f_x = f_{xx}/4 = 4\text{MHz}$ (0.25 μ s)
- TBDATAH = 8.795 μ s/0.25 μ s = 35.18, TBDATAL = 17.59 μ s/0.25 μ s = 70.36
- Set P4.3 to TBPWM mode.

```

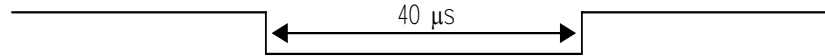
START   ORG      0100H           ; Reset address
        DI
        SB1
        LD      0F7H,#5FH       ; Extra command only for debugging(1)
        SB0
        ; Extra command only for debugging(1)
        ; Extra command only for debugging(1)
        .
        .
        LD      TBDATAL,#(35-1) ; Set 17.5  $\mu$ s
        LD      TBDATAH,#(70-1) ; Set 8.75  $\mu$ s
        LD      TBCON,#00100111B ; Clock Source  $\leftarrow$  fxx/4
        ; Disable Timer B interrupt.
        ; Select repeat mode for Timer B.
        ; Start Timer B operation.
        ; Set Timer B Output flip-flop (T-FF) high.
        ;
        LD      P1CONLH,#0C0H    ; Set P1.4 to TBPWM mode.
        ; This command generates 38 kHz, 1/3 duty pulse signal
        ; through P1.4.
        .
        .
        .

```

NOTE: In debug mode, you have to include three extra commands in initial routine to operate Ports correctly. If you omit these commands, Port do not operate correctly. After you have finished your program and before assembling, you have to remove these three commands.

 **PROGRAMMING TIP — To generate a one pulse signal through P2.0**

This example sets Timer B to the one shot mode, sets the oscillation frequency as the Timer B clock source, and TBDATAH and TBDATAL to make a 40 μ s width pulse. The program parameters are:



- Timer B is used in one shot mode
- Oscillation frequency is 4 MHz ($f_x=1/4$ clock = 1 μ s)
- TBDATAH = 40 μ s / 1 μ s = 40, TBDATAL = 1
- Set P2.0 to TBPWM mode

```

START      ORG      0100H          ; Reset address
           DI
           SB1          ; Extra command only for debugging(1)
           LD      0F7H,#5FH      ; Extra command only for debugging(1)
           SB0          ; Extra command only for debugging(1)
           .
           .
           LD      TBDATAH,# (40-1) ; Set 40  $\mu$ s
           LD      TBDATAL,# 1     ; Set any value except 00H
           LD      TBCON,#00010001B ; Clock Source  $\leftarrow$   $f_x/4$ 
                                           ; Disable Timer B interrupt.
                                           ; Select one shot mode for Timer B.
                                           ; Stop Timer B operation.
           LD      P2CONL,#03H     ; Set Timer B output flip-flop (T-FF) high
                                           ; Set P2.0 to TBPWM mode.
           .
           .
PULSE_OUT: LD      TBCON,#00000101B ; Start Timer B operation
                                           ; to make the pulse at this point.
           .
           .
           .
           .
           .
           .
           .

```

NOTE: In debug mode, you have to include three extra commands in initial routine to operate Ports correctly.
 If you omit these commands, Port do not operate correctly.
 After you have finished your program and before assembling, you have to remove these three commands.

 **PROGRAMMING TIP — Using the Timer A**

```

        ORG      0000h

        VECTOR   0C0h,TAMC_INT
        VECTOR   0C2h,TAOV_INT

        ORG      0100h

INITIAL:
        DI
        SB1      ; Extra command only for debugging(1)
        LD       0F7H,#5FH ; Extra command only for debugging(1)
        SB0      ; Extra command only for debugging(1)

        LD       SPH,#00000000b ; Set stack area
        LD       SPL,#00000000b
        LD       BTCON,#10100011b ; Disable watch-dog

        LD P1CONL,#0ABH ; Enable TAOUT output
        SB1
        LD TADATA,#80h
        LD TACON,#01001010b ; Match interrupt enable
                          ; 6.55 ms duration (10 MHz x'tal)
        SB0
        EI

MAIN:
        •
        MAIN ROUTINE
        •
        JR      T,MAIN

TAMC_INT:
        •
        Interrupt service routine
        •
        IRET

TAOV_INT:
        Interrupt service routine
        IRET

.END

```

NOTE: In debug mode, you have to include three extra commands in initial routine to operate Ports correctly. If you omit these commands, Port do not operate correctly. After you have finished your program and before assembling, you have to remove these three commands.

 **PROGRAMMING TIP — Using the Timer B**

```

        ORG      0000h

        VECTOR  0BEh,TBUN_INT

        ORG      0100h

INITIAL:
        DI
        SB1
        LD      0F7H,#5FH          ; Extra command only for debugging(1)
        SB0
                                   ; Extra command only for debugging(1)
                                   ; Extra command only for debugging(1)

        LD      IMR,#00000001b    ; Enable IRQ0 interrupt
        LD      SPH,#00000000b    ; Set stack area
        LD      SPL,#00000000b
        LD      BTCON,#10100011b ; Disable Watch-dog

        LD      P2CONL,#03H      ; Enable TBPWM output

        LD      TBDATAH,#80h
        LD      TBDATAAL,#80h
        LD      TBCON,#11101110b ; Enable interrupt, fxx/256, Repeat
                                   ; Duration 6.605ms (10 MHz x'tal)

        EI

MAIN:
        •
        MAIN ROUTINE
        •

        JR      T,MAIN

TBUN_INT:
        •
        Interrupt service routine
        •
        IRET

        .END

```

NOTE: In debug mode, you have to include three extra commands in initial routine to operate Ports correctly. If you omit these commands, Port do not operate correctly. After you have finished your program and before assembling, you have to remove these three commands.

12

16-BIT TIMER 1(0,1)

OVERVIEW

The S3C84H5/F84H5 has two 16-bit timer/counters. The 16-bit timer 1(0,1) is an 16-bit general-purpose timer/counter. Timer 1(0,1) has three operating modes, one of which you select using the appropriate T1CON0, T1CON1 setting is

- Interval timer mode (Toggle output at T1OUT0, T1OUT1 pin)
- Capture input mode with a rising or falling edge trigger at the T1CAP0, T1CAP1 pin
- PWM mode (T1PWM0, T1PWM1); PWM output shares their output port with T1OUT0, T1OUT1 pin

Timer 1(0,1) has the following functional components:

- Clock frequency divider (f_{xx} divided by 1024, 256, 64, 8, 1) with multiplexer
- External clock input pin (T1CK0, T1CK1)
- A 16-bit counter (T1CNTH0/L0, T1CNTH1/L1), a 16-bit comparator, and two 16-bit reference data register (T1DATAH0/L0, T1DATAH1/L1)
- I/O pins for capture input (T1CAP0, T1CAP1), or match output (T1OUT0, T1OUT1)
- Timer 1(0) overflow interrupt (IRQ2, vector C6H) and match/capture interrupt (IRQ2, vector C4H) generation
- Timer 1(1) overflow interrupt (IRQ2, vector CAH) and match/capture interrupt (IRQ2, vector C8H) generation
- Timer 1(0) control register, T1CON0 (set 1, E8H, Bank 1, read/write)
- Timer 1(1) control register, T1CON1 (set 1, E9H, Bank 1, read/write)

FUNCTION DESCRIPTION

Timer 1(0,1) Interrupts (IRQ2, Vectors C4H, C6H, C8H and CAH)

The timer 1(0) module can generate two interrupts, the timer 1(0) overflow interrupt (T1OVF0), and the Timer 1(0) match/capture interrupt (T1INT0). T1OVF0 is interrupt level IRQ2, vector C6H. T1INT0 also belongs to interrupt level IRQ2, but is assigned the separate vector address, C4H.

A timer 1(0) overflow interrupt pending condition is automatically cleared by hardware when it has been serviced. A timer 1(0) match/capture interrupt, T1INT0 pending condition is also cleared by hardware when it has been serviced.

The timer 1(1) module can generate two interrupts, the timer 1(1) overflow interrupt (T1OVF1), and the timer 1(1) match/capture interrupt (T1INT1). T1OVF1 is interrupt level IRQ2, vector CAH. T1INT1 also belongs to interrupt level IRQ2, but is assigned the separate vector address, C8H.

A timer 1(1) overflow interrupt pending condition is automatically cleared by hardware when it has been serviced. A timer 1(1) match/capture interrupt, T1INT1 pending condition is also cleared by hardware when it has been serviced.

Interval Mode (match)

The timer 1(0) module can generate an interrupt: the timer 1(0) match interrupt (T1INT0). T1INT0 belongs to interrupt level IRQ2, and is assigned the separate vector address, C4H. In interval timer mode, a match signal is generated and T1OUT0 is toggled when the counter value is identical to the value written to the Timer 1 reference data registers, T1DATAH0 and T1DATAL0. The match signal generates a timer 1(0) match interrupt (T1INT0, vector C4H) and clears the counter value.

The timer 1(1) module can generate an interrupt: the timer 1(1) match interrupt (T1INT1). T1INT1 belongs to interrupt level IRQ2, and is assigned the separate vector address, C8H. In interval timer mode, a match signal is generated and T1OUT1 is toggled when the counter value is identical to the value written to the Timer 1 reference data register, T1DATAH1 and T1DATAL1. The match signal generates a timer 1(1) match interrupt (T1INT1, vector C8H) and clears the counter value.

Capture Mode

In capture mode for timer 1(0), a signal edge that is detected at the T1CAP0 pin opens a gate and loads the current counter value into the timer 1 data registers (T1DATAH0, T1DATAL0 for rising edge, or falling edge). You can select rising or falling edge to trigger this operation. The timer 1(0) also gives you capture input source, the signal edge at the T1CAP0 pin. You select the capture input by setting the value of the timer 1(0) capture input selection bit in the port 0 control register high, P0CONH, (set 1 bank0, E6H).

Both kinds of timer 1(0) interrupts (T1OVF0, T1INT0) can be used in capture mode, the timer 1(0) overflow interrupt is generated whenever a counter overflow occurs, the timer 1(0) capture interrupt is generated whenever the counter value is loaded into the timer 1 data register.

By reading the captured data value in T1DATAH0, T1DATAL0, and assuming a specific value for the timer 1(0) clock frequency, you can calculate the pulse width (duration) of the signal that is being input at the T1CAP0 pin.

In capture mode for Timer 1(1), a signal edge that is detected at the T1CAP1 pin opens a gate and loads the current counter value into the timer 1 data register (T1DATAH1, T1DATAL1 for rising edge, or falling edge). You can select rising or falling edges to trigger this operation. The timer 1(1) also gives you capture input source, the signal edge at the T1CAP1 pin. You select the capture input by setting the value of the timer 1(1) capture input selection bit in the port 0 control register low, P0CONL, (set 1 bank0, E7H).

Both kinds of timer 1(1) interrupts (T1OVF1, T1INT1) can be used in capture mode, the timer 1(1) overflow interrupt is generated whenever a counter overflow occurs, the timer 1(1) capture interrupt is generated whenever the counter value is loaded into the timer 1 data register.

By reading the captured data value in T1DATAH1, T1DATAL1, and assuming a specific value for the timer 1(1) clock frequency, you can calculate the pulse width (duration) of the signal that is being input at the T1CAP1 pin.

PWM Mode

Pulse width modulation (PWM) mode lets you program the width (duration) of the pulse that is output at the T1OUT0, T1OUT1 pin. As in interval timer mode, a match signal is generated when the counter value is identical to the value written to the timer 1(0,1) data registers. In PWM mode, however, the match signal does not clear the counter but can generate a match interrupt. Instead, it runs continuously, overflowing at FFFFH, and then continuously increasing from 0000H. Whenever an overflow occurs, an overflow (T1OVF0,1) interrupt can be generated.

Although you can use the match or overflow interrupts in the PWM mode, these interrupts are not typically used in PWM-type applications. Instead, the pulse at the T1OUT0, T1OUT1 pin is held to low level as long as the reference data value is less than or equal to (\leq) the counter value and then the pulse is held to high level for as long as the data value is greater than ($>$) the counter value. One pulse width is equal to t_{CLK} .

TIMER 1(0,1) CONTROL REGISTER (T1CON0, T1CON1)

You use the timer 1(0,1) control register, T1CON0, T1CON1, to:

- Select the timer 1(0,1) operating mode (Interval timer, Capture mode, PWM mode)
- Select the timer 1(0,1) input clock frequency
- Clear the timer 1(0,1) counter, T1CNTH0/L0, T1CNTH1/L1
- Enable the timer 1(0,1) overflow interrupt
- Enable the timer 1(0,1) match/capture interrupt

T1CON0 is located in set 1 and Bank 1 at address E8H, and is read/write addressable using Register addressing mode. T1CON1 is located in set 1 and Bank 1 at address E9H, and is read/write addressable using Register addressing mode.

A reset clears T1CON0, T1CON1 to '00H'. This sets timer 1(0,1) to normal interval timer mode, selects an input clock frequency of $f_{xx}/1024$, and disables all timer 1(0,1) interrupts. To disable the counter operation, please set T1CON(0,1).7-5 to 111B. You can clear the timer 1(0,1) counter at any time during normal operation by writing a "1" to T1CON(0,1).3.

The timer 1(0) overflow interrupt (T1OVF0) is interrupt level IRQ2 and has the vector address C6H. And, the timer 1(1) overflow interrupt (T1OVF1) is interrupt level IRQ2 and has the vector address CAH.

To generate the exact time interval, you should write "1" to T1CON(0,1).2 and clear appropriate pending bits of the TINTPND register.

To detect a match/capture or overflow interrupt pending condition when T1INT0, T1INT1 or T1OVF0, T1OVF1 is disabled, the application program should poll the pending bit TINTPND register, bank 1, address E0H.

When a "1" is detected, a timer 1(0,1) match/capture or overflow interrupt is pending. When the sub-routine has been serviced, the pending condition must be cleared by software by writing a "0" to the interrupt pending bit. If interrupts (match/capture or overflow) are enabled, the pending bit is cleared automatically by hardware.

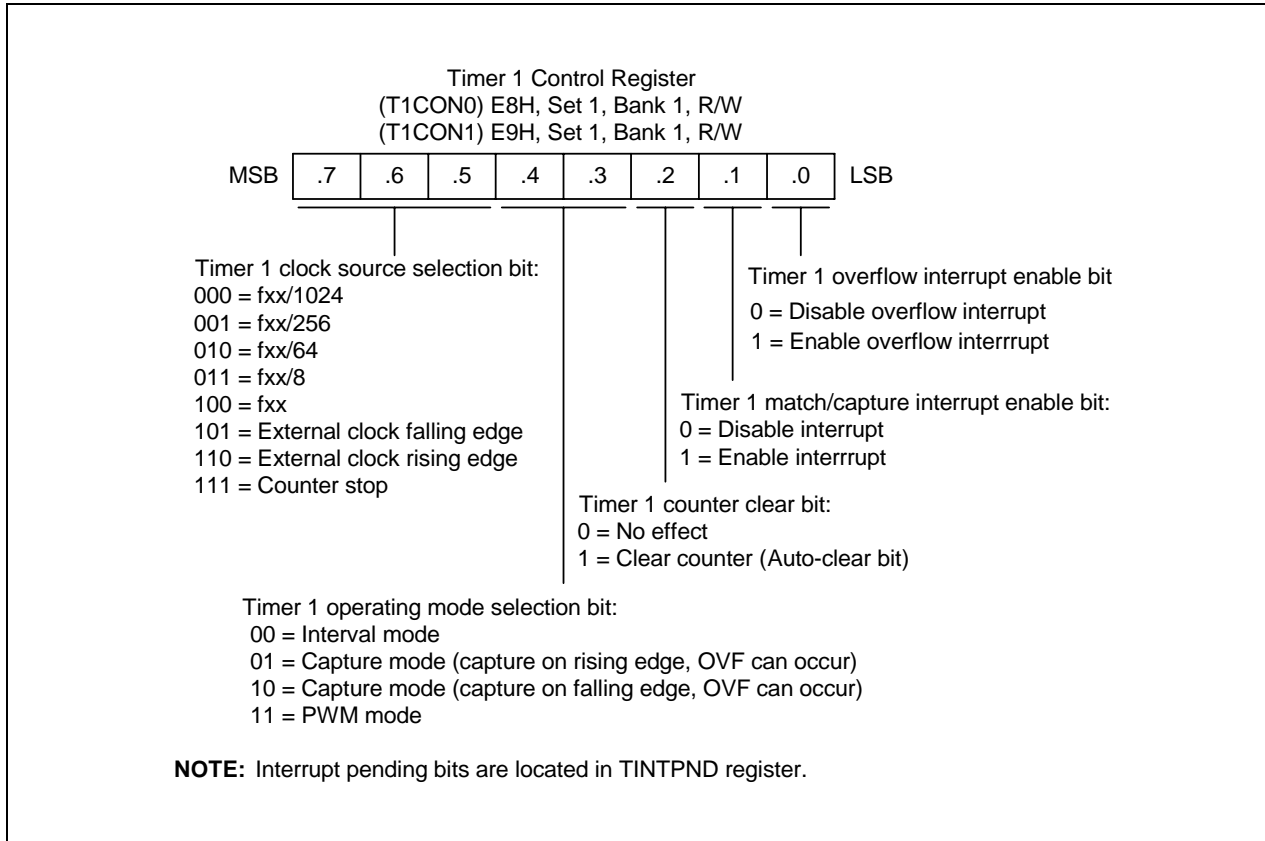


Figure 12-1. Timer 1(0,1) Control Register (T1CON0, T1CON1)

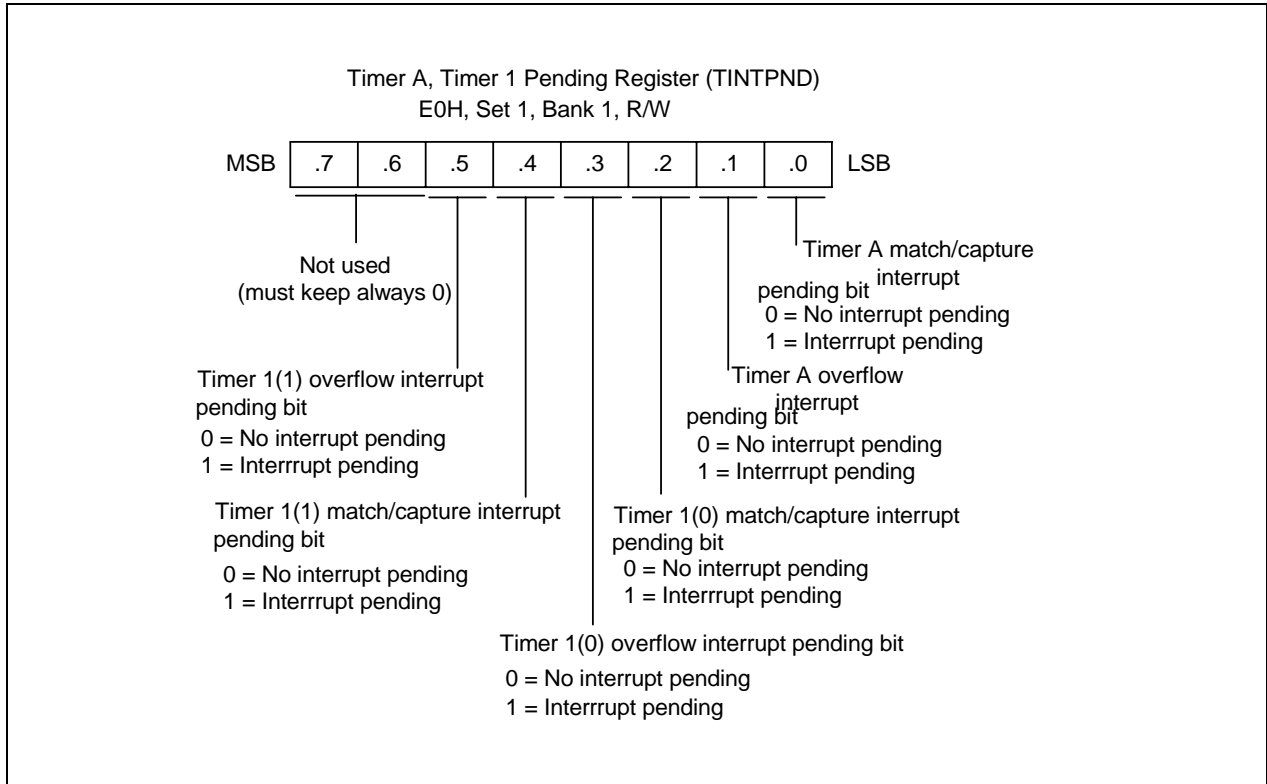


Figure 12-2. Timer A, Timer 1(0,1) Pending Register (TINTPND)

BLOCK DIAGRAM

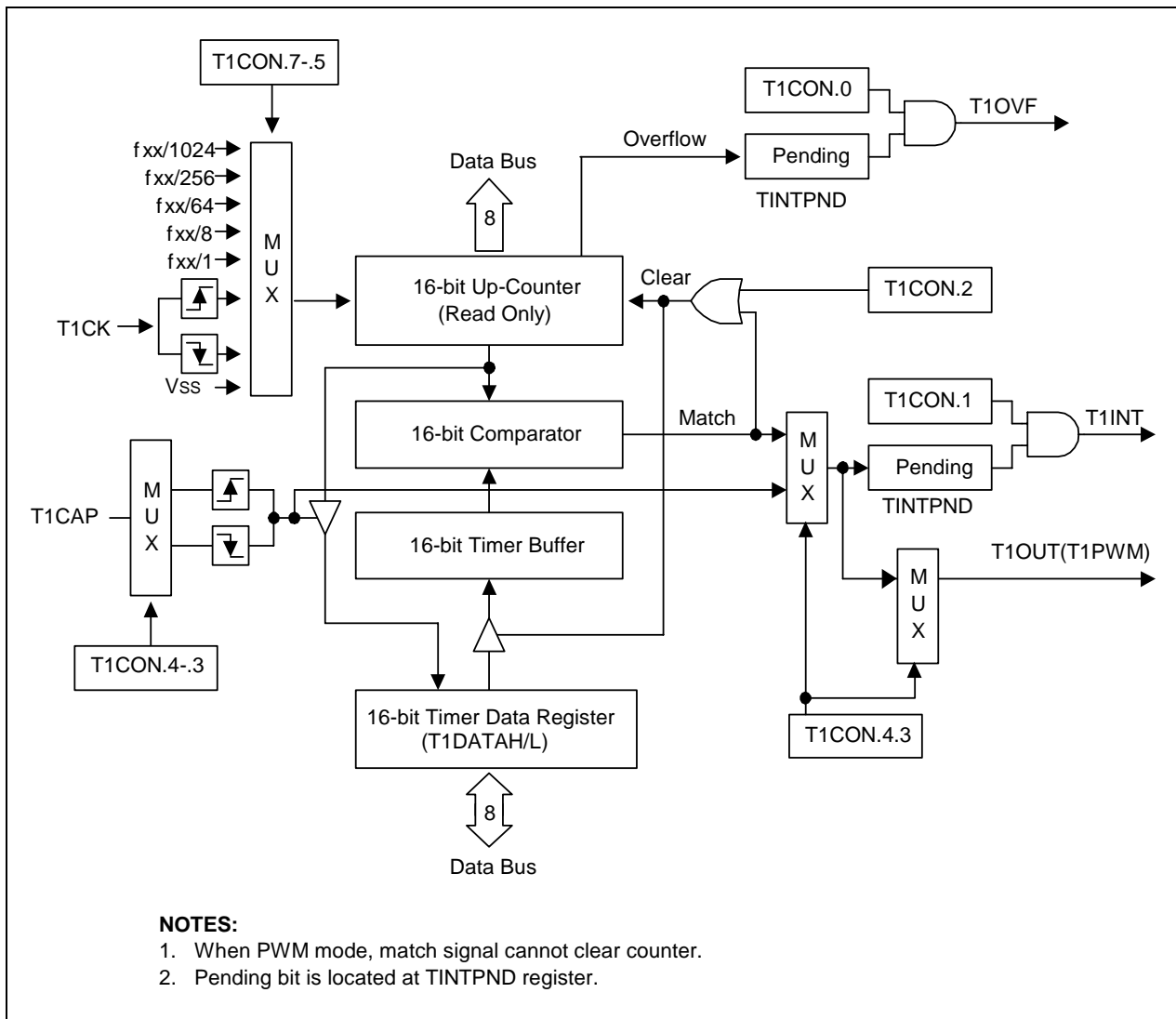


Figure 12-3. Timer 1(0,1) Functional Block Diagram

 **PROGRAMMING TIP — Using the Timer 1(0)**

```

        ORG      0000h

        VECTOR   0C4h,TIM1_INT

        ORG      0100h

INITIAL:
        LD       SYM,#00h           ; Disable Global/Fast interrupt

        SB1
        LD       0F7H,#5FH         ; Extra command only for debugging(1)
        SB0
        ; Extra command only for debugging(1)
        ; Extra command only for debugging(1)

        LD       IMR,#00001000b    ; Enable IRQ2 interrupt
        LD       SPH,#00000000b    ; Set stack area
        LD       SPL,#00000000b
        LD       BTCON,#10100011b ; Disable Watch-dog

        SB1
        LD       T1CON0,#01000110b ; Enable interrupt ,fxx/64, Interval,
        ; Interval= 1.536 ms (10 MHz x'tal)

        LDW      T1DATAH0,#00F0h   ; T1DATAH0=00h, T1DATAH0=F0h
        SB0

        EI

MAIN:
        •
        MAIN ROUTINE
        •
        JR       T,MIAN

TIM1_INT:
        •
        •
        Interrupt service routine
        •
        •
        IRET

        END

```

NOTE: In debug mode, you have to include three extra commands in initial routine to operate Ports correctly. If you omit these commands, Port do not operate correctly. After you have finished your program and before assembling, you have to remove these three commands.

13

10-BIT PWM (PULSE WIDTH MODULATION)

OVERVIEW

This microcontroller has the 10-bit PWM circuit. The operation of all PWM circuit is controlled by a single control register, PWMCON.

The PWM counter is a 10-bit incrementing counter. It is used by the 10-bit PWM circuits. To start the counter and enable the PWM circuits, you set PWMCON.2 to "1". If the counter is stopped, it retains its current count value; when re-started, it resumes counting from the retained count value. When there is a need to clear the counter you set PWMCON.3 to "1".

You can select a clock for the PWM counter by set PWMCON.6–.7. Clocks which you can select are $f_{OSC}/64$, $f_{OSC}/8$, $f_{OSC}/2$, $f_{OSC}/1$.

FUNCTION DESCRIPTION

PWM

The 10-bit PWM circuits have the following components:

- 8-bit comparator and extension cycle circuit
- 8-bit reference data register (PWMDATAH .7–.0)
- 2-bit extension data register (PWMDATAL .1–.0)
- PWM output pins (P2.1/PWM)

PWM Counter

To determine the PWM module's base operating frequency, the upper 8-bits of counter is compared to the PWM data (PWMDATAH .7–.0). In order to achieve higher resolutions, the lower 2-bits of the PWMDATAL counter can be used to modulate the "stretch" cycle. To control the "stretching" of the PWM output duty cycle at specific intervals, the lower 2-bits of PWMDATAL counter value is compared with the PWMDATAL .1–.0.

PWM Data and Extension Registers

PWM (duty) data registers located in Set 1, Bank1 at address F3H-F4H, determine the output value generated by each 10-bit PWM circuit.

To program the required PWM output, you load the appropriate initialization values into the 8-bit reference data register (PWMDATAH .7–.0) and the 2-bit extension data register (PWMDATAL .1–.0). To start the PWM counter, or to resume counting, you set PWMCON.2 to "1".

A reset operation disables all PWM output. The current counter value is retained when the counter stops. When the counter starts, counting resumes at the retained value.

PWM Clock Rate

The timing characteristics of PWM output is based on the f_{OSC} clock frequency. The PWM counter clock value is determined by the setting of PWMCON.6–.7.

Table 13-1. PWM Control and Data Registers

Register Name	Mnemonic	Address	Function
PWM data registers	PWMDATAH .7–.0	F3H, Set 1 Bank 1	8-bit PWM basic cycle frame value
	PWMDATAL .1–.0	F4H, Set 1 Bank 1	2-bit extension ("stretch") value
PWM control registers	PWMCON	F5H, Set 1 Bank 1	PWM counter stop/start (resume), and PWM counter clock settings

PWM Function Description

The PWM output signal toggles to Low level whenever the 8-bit counter matches the reference data register (PWMDATAH). If the value in the PWMDATAH register is not zero, an overflow of the 8-bits of counter causes the PWM output to toggle to High level. In this way, the reference value written to the reference data register determines the module's base duty cycle.

The value in the lower 2-bits of PWMDATAL counter is compared with the extension settings in the 2-bit extension data register (PWMDATAL .1–.0). This lower 2-bits of counter value, together with extension logic and the PWM module's extension data register, is then used to "stretch" the duty cycle of the PWM output. The "stretch" value is one extra clock period at specific intervals, or cycles (see Table 12-2).

If, for example, the value in the extension PWMDATAH register is '00B' and PWMDATAL register is '01B', the 2nd cycle will be one pulse longer than the other 3 cycles. If the base duty cycle is 50 %, the duty of the 2nd cycle will therefore be "stretched" to approximately 51% duty. For example, if you write 10B to the extension data register, all odd-numbered pulses will be one cycle longer. If you write 11H to the extension data register, all pulses will be stretched by one cycle except the 4th pulse. PWM output goes to an output buffer and then to the corresponding PWM output pin. In this way, you can obtain high output resolution at high frequencies.

Table 13-2. PWM output "stretch" Values for Extension Data Register (PWMDATAL .1-.0)

PWMDATAL Bit (Bit1–Bit0)	"Stretched" Cycle Number
00	–
01	2
10	1, 3
11	1, 2, 3

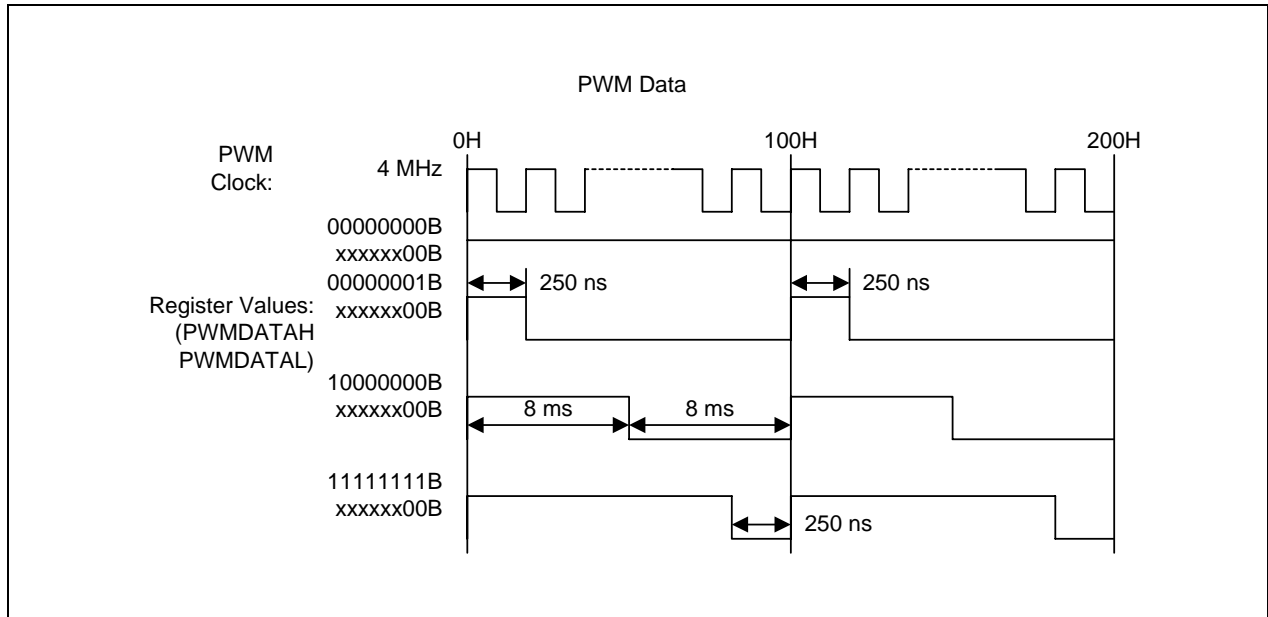


Figure 13-1. 10-Bit PWM Basic Waveform

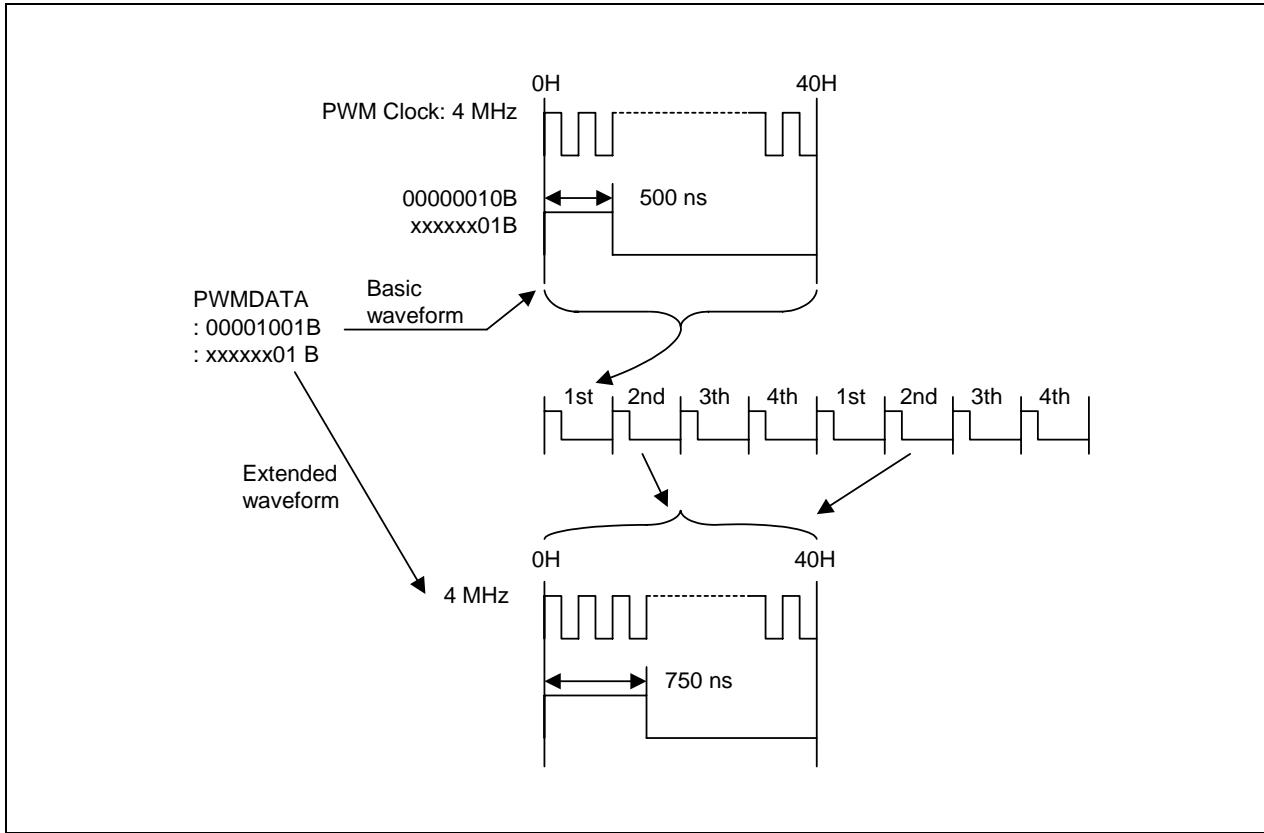


Figure 13-2. 10-Bit Extended PWM Waveform

PWM CONTROL REGISTER (PWMCON)

The control register for the PWM module, PWMCON, is located at register address F5H. PWMCON is used the 10-bit PWM modules. Bit settings in the PWMCON register control the following functions:

- PWM counter clock selection
- PWM data reload interval selection
- PWM counter clear
- PWM counter stop/start (or resume) operation
- PWM counter overflow (10-bit counter overflow) interrupt control

A reset clears all PWMCON bits to logic zero, disabling the entire PWM module.

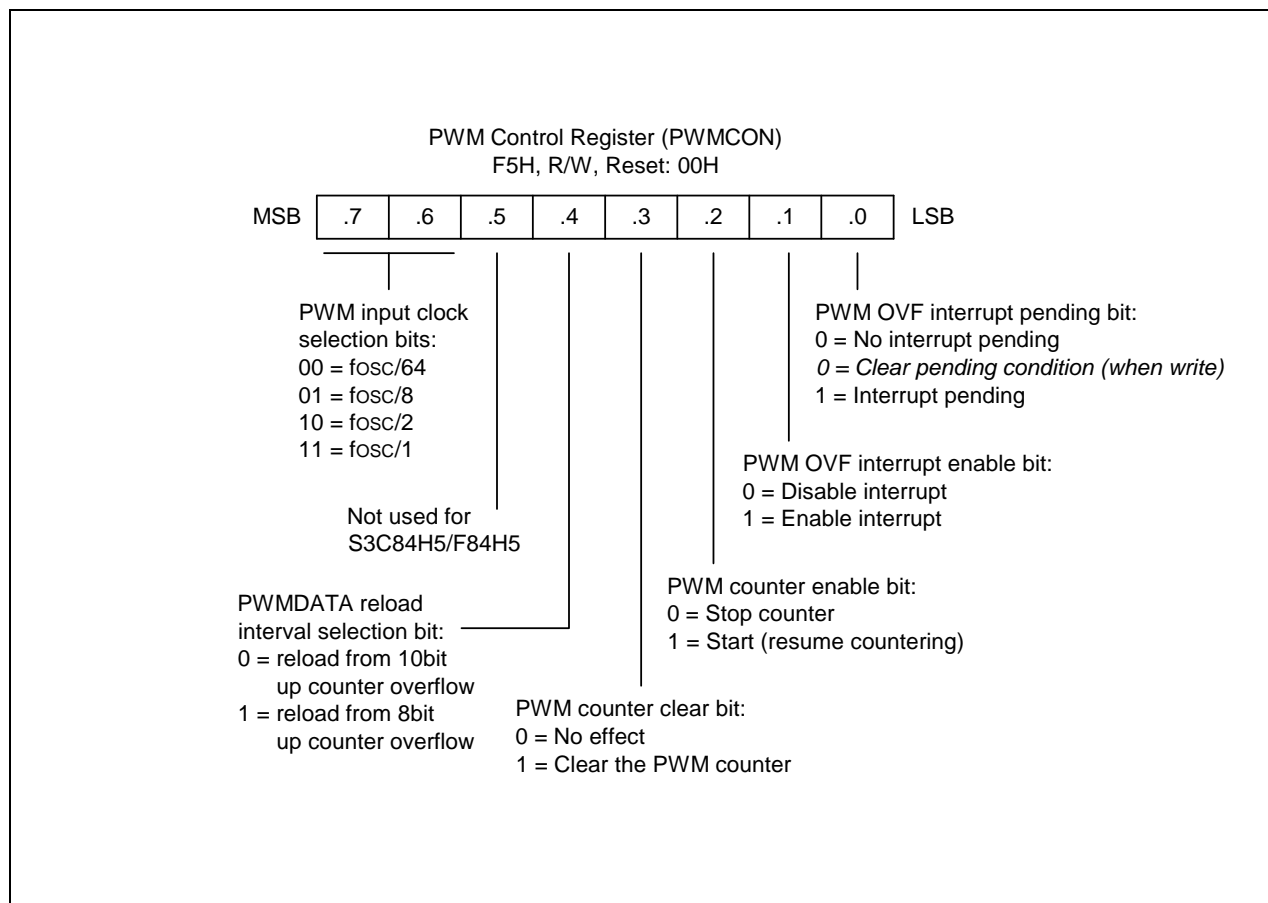


Figure 13-3. PWM Control Register (PWMCON)

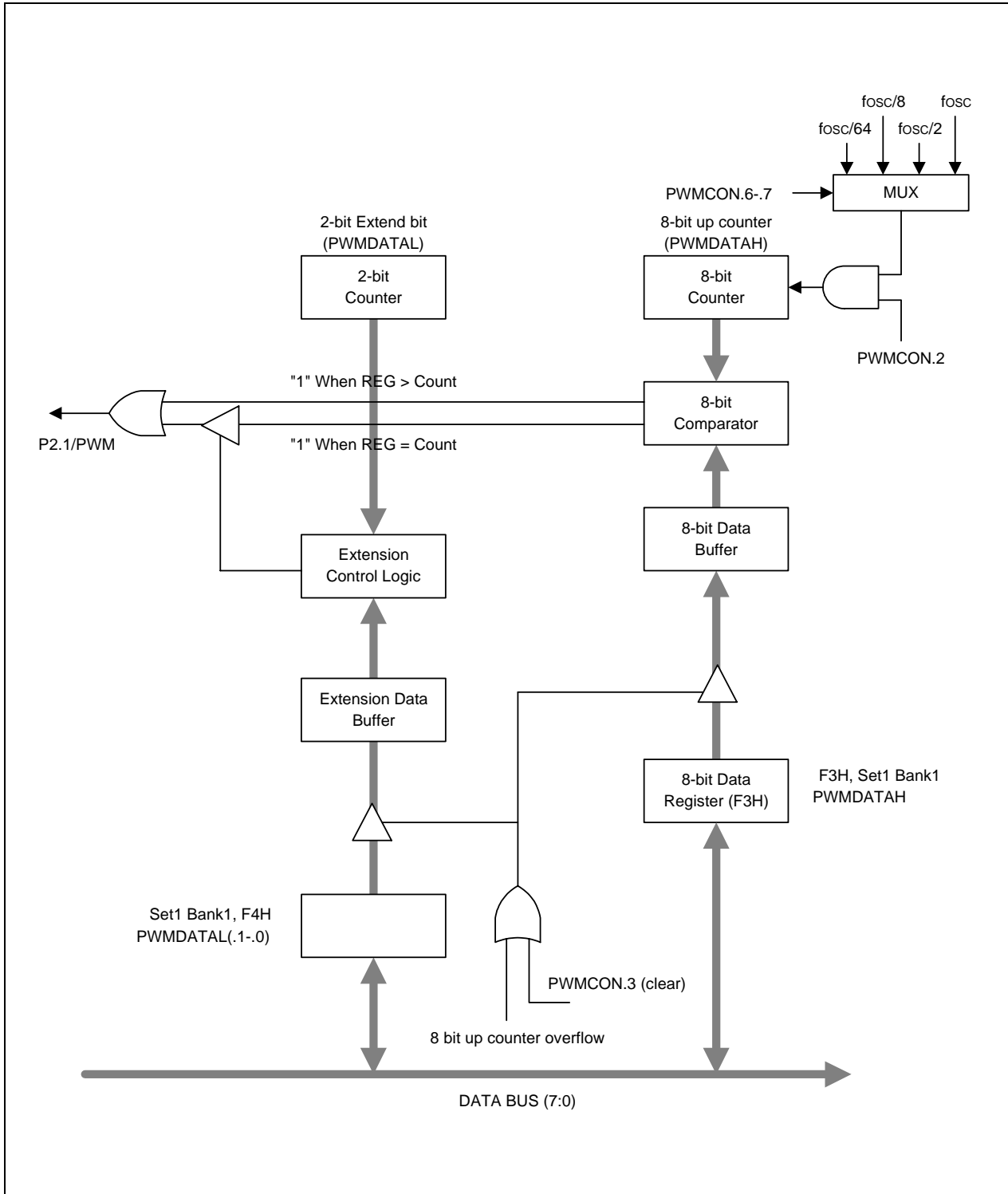


Figure 13-4. PWM Functional Block Diagram

 **PROGRAMMING TIP — Programming the PWM Module to Sample Specifications**

;-----<< Interrupt Vector Address >>

```
ORG      0000H
         VECTOR    0DAH,INT_PWM
```

;-----<< Initialize System and Peripherals >>

```
RESET:   ORG      0100H
         DI              ; Disable interrupt
         SB1             ; Extra command only for debugging(1)
         LD      0F7H,#5FH ; Extra command only for debugging(1)
         SB0             ; Extra command only for debugging(1)

         LD      BTCON,#10100011B ; Watchdog disable
         .
         .
         LD      P2CONL,#00001100B ; Configure P2.1 PWM output
         LD      PWMCON,#00000110B ; fOSC/64, counter/interrupt enable

         LD      PWMDATAH,,#80H
         LD      PWMDATAL,#0

         EI              ; Enable interrupt
```

;-----<< Main loop >>

```
MAIN:
         .
         .
         JR      t,MAIN
```

;-----<< Interrupt Service Routines >>

```
INT_PWM: ; PWM interrupt service routine
         .
         AND      PWMCON,#11111110B ; Pending bit clear
         IRET
         .
         END
```

NOTE: In debug mode, you have to include three extra commands in initial routine to operate Ports correctly. If you omit these commands, Port do not operate correctly. After you have finished your program and before assembling, you have to remove these three commands.

14 SERIAL I/O INTERFACE

OVERVIEW

Serial I/O module, SIO can interface with various types of external devices that require serial data transfer. The components of each SIO function block are:

- 8-bit control register (SIOCON)
- Clock selection logic
- 8-bit data buffer (SIODATA)
- 8-bit presale (SIOPS)
- 3-bit serial clock counter
- Serial data I/O pins (SI, SO)
- External clock input pin (SCK)

SIO module can transmit or receive 8-bit serial data at a frequency determined by its corresponding control register settings. To ensure flexible data transmission rates, you can select an internal or external clock source.

PROGRAMMING PROCEDURE

To program the SIO module, follow these basic steps:

1. Configure the I/O pins at port 2 (SO, SCK, SI) by loading the appropriate value to the P2CONL/H Register.
2. Load an 8-bit value to the SIOCON control register to properly configure the serial I/O module. In this operation, SIOCON.2 must be set to "1" to enable the data shifter.
3. For interrupt generation, set the serial I/O interrupt enable bit (SIOCON.1) to "1".
4. When you the transmit data to the serial buffer, write data to SIODATA and set SIOCON.3 to 1, the shift operation starts.
5. When the shift operation (transmit/receive) is completed, the SIO pending bit (SIOCON.0) is set to "1" and an SIO interrupt request is generated.

SERIAL I/O CONTROL REGISTERS (SIOCON)

The control registers for serial I/O interface, SIOCON, is located in Set1, Bank 1 at F2H. It has the control settings for SIO module.

- Clock source selection (internal or external) for shift clock
- Interrupt enable
- Edge selection for shift operation
- Clear 3-bit counter and start shift operation
- Shift operation (transmit) enable
- Mode selection (transmit/receive or receive-only)
- Data direction selection (MSB first or LSB first)

A reset clears the SIOCON value to "00H". This configures the corresponding module with an internal clock source at the SCK, selects receive-only operating mode, and clears the 3-bit counter. The data shift operation and the interrupt are disabled. The selected data direction is MSB-first.

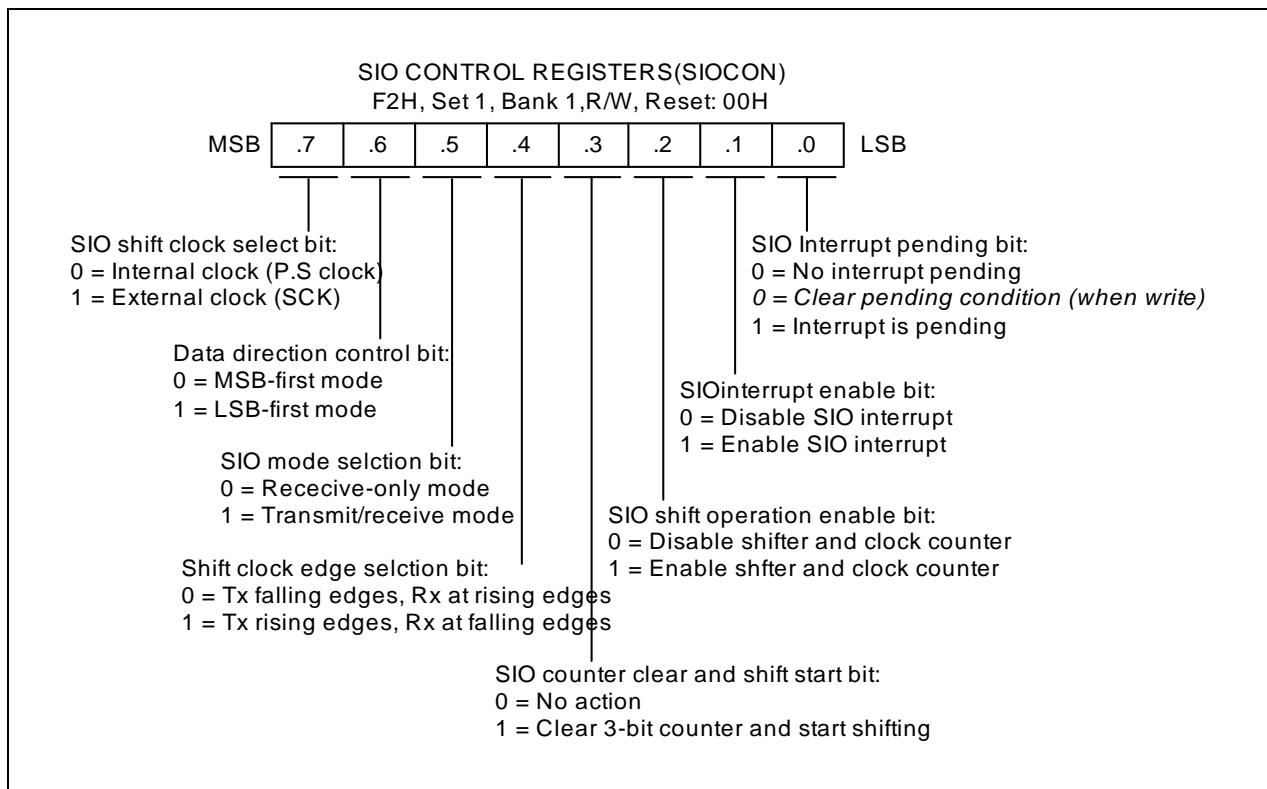


Figure 14-1. Serial I/O Interface Control Register (SIOCON)

SIO PRESCALER REGISTER (SIOPS)

The control register for serial I/O interface module, SIOPS is located in Set 1, Bank 1 at F0H. The value stored in the SIO prescaler registers, SIOPS, lets you determine the SIO clock rate (baud rate) as follows:

$$\text{Baud rate} = \text{Input clock}(X_{in}/4) / (\text{SIOP} + 1), \text{ or external SCK input clock}$$

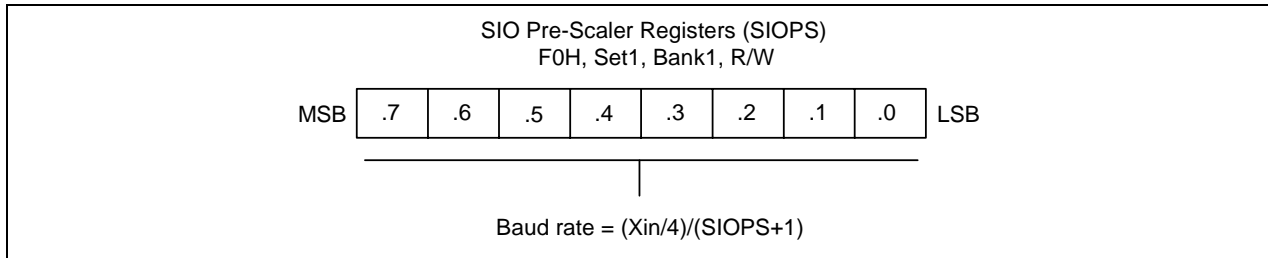


Figure 14-2. SIO Pre-scaler Register (SIOPS)

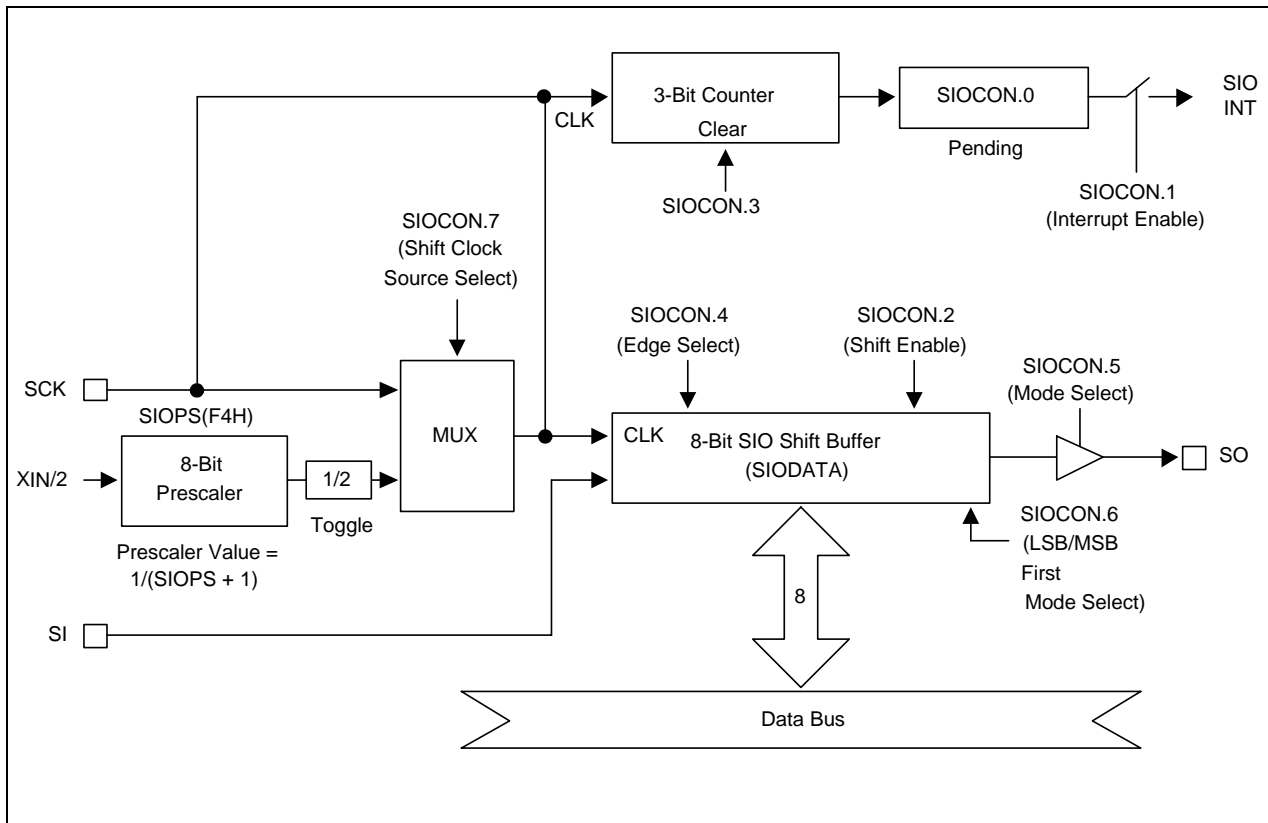


Figure 14-3. SIO Functional Block Diagram

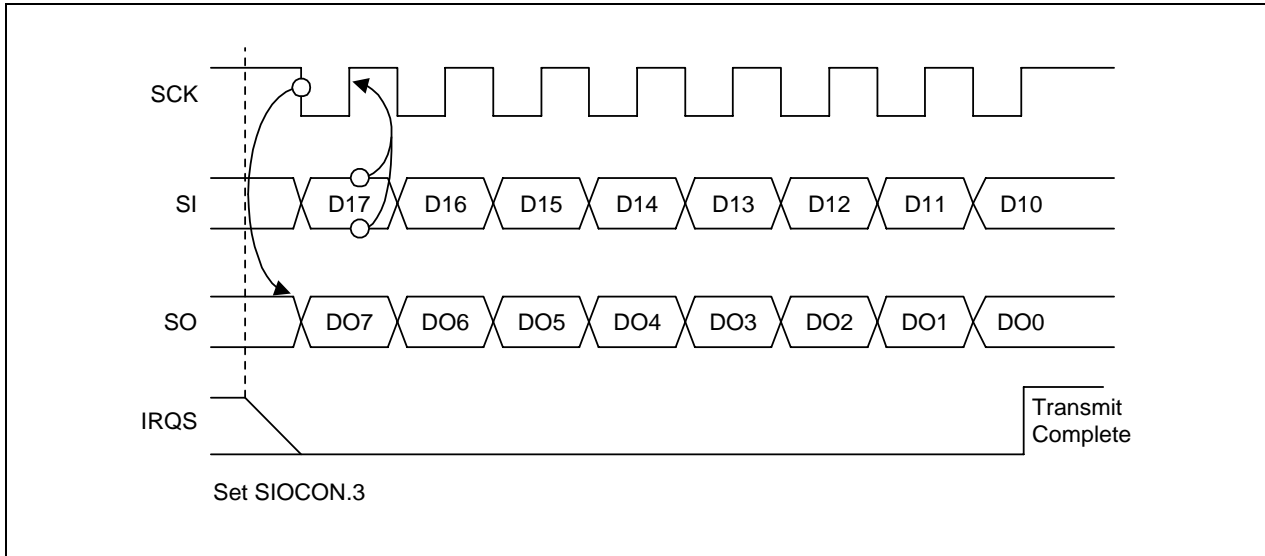


Figure 14-4. Serial I/O Timing in Transmit-Receive Mode (Tx at falling, SIOCON.4 = 0)

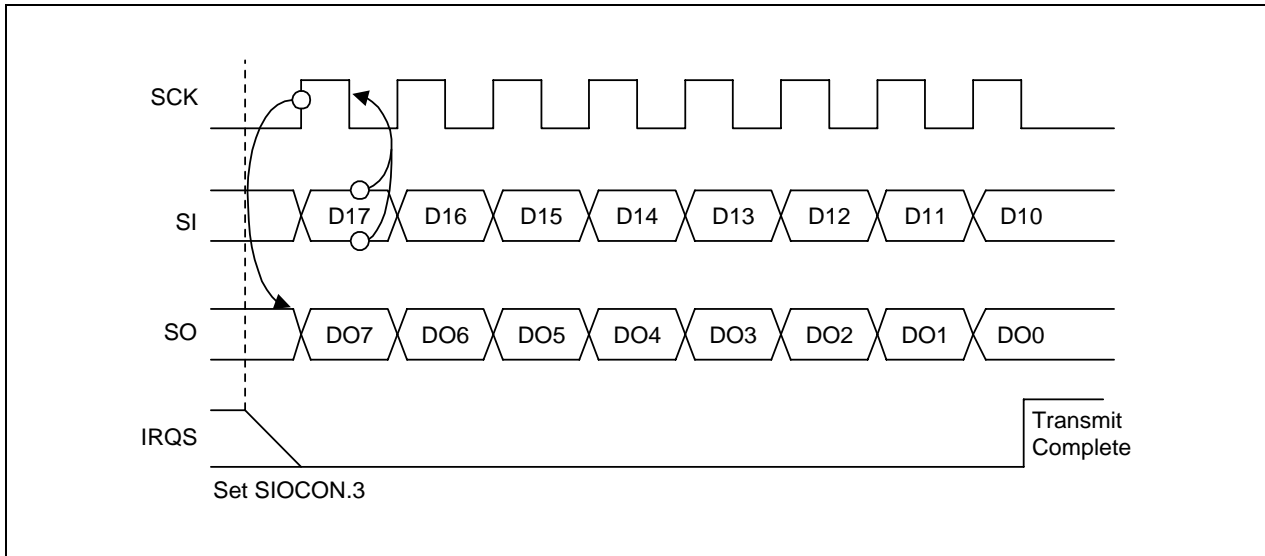


Figure 14-5. Serial I/O Timing in Transmit-Receive Mode (Tx at rising, SIOCON.4 = 1)

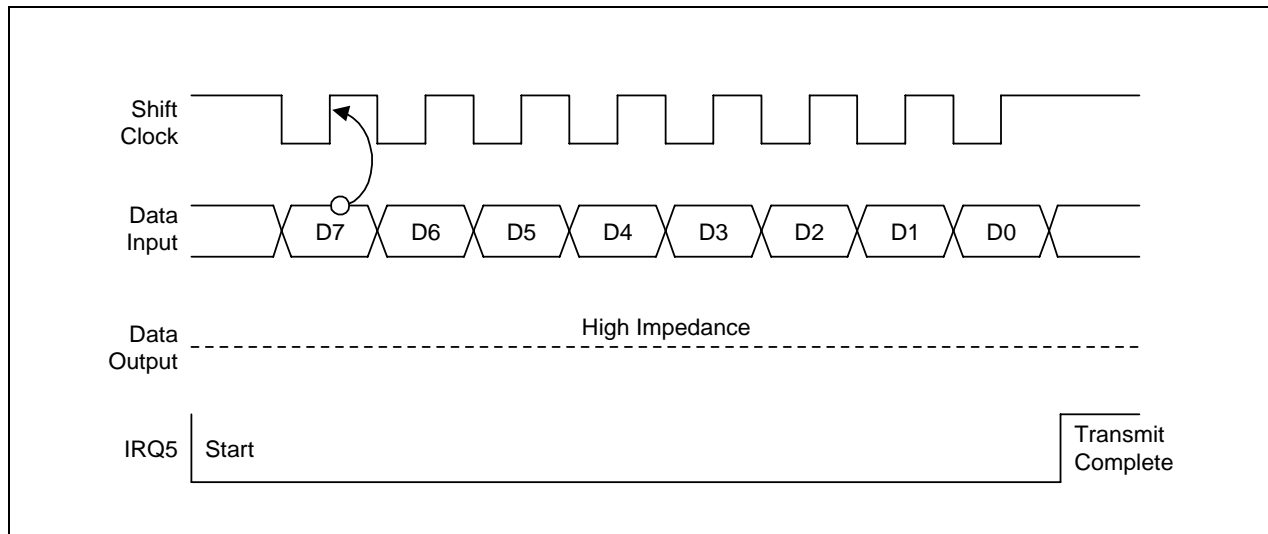


Figure 14-6. Serial I/O Timing in Receive-Only Mode

PROGRAMMING TIP — SIO

```

        ORG      0000H

        VECTOR  00H, INT_SIO

INITIAL:
        ORG      0100H

        DI
        SB1                      ; Extra command only for debugging(1)
        LD      0F7H, #5FH        ; Extra command only for debugging(1)
        SB0                      ; Extra command only for debugging(1)

        LD      BTCON, #10100010B ; Watch-dog disable
        LD      CLKCON, #00011000B ; non-divided CPU clock
        LD      SPL, #00H          ;

        .
        .
        LD      P2CONH, #10101111B ; SIO setting
LD P2CONL, #00101010B
        .
        .
        LD      SIOCON, #00100110B ; Enable SIO/Interrupt
        LD      SIOPS, #20         ; setting baud rate
        .
        .
        EI

```

 **PROGRAMMING TIP — SIO (Continued)**

MAIN:

```
•  
•  
•  
CALL    SUB_SIO          ; Data transmit routine
```

```
•  
•  
•  
JP      MAIN
```

SUB_SIO:

```
LD      SIODATA, TRANSBUF ; 1-byte transmission  
OR      SIOCON, #00001000B ; Shift start (8-bit transmit)
```

```
•  
•  
RET
```

INT_SIO:

```
AND     SIOCON, #11111110 ; Pending bit clear
```

```
•  
•  
•  
IRET
```

NOTE: In debug mode, you have to include three extra commands in initial routine to operate Ports correctly. If you omit these commands, Port do not operate correctly. After you have finished your program and before assembling, you have to remove these three commands.

15

UART

OVERVIEW

The UART block has a full-duplex serial port with programmable operating modes: There is one synchronous mode and three UART (Universal Asynchronous Receiver/Transmitter) modes:

- Shift Register I/O with baud rate of $fx/(16 \times (16\text{bit BRDATA}+1))$
- 8-bit UART mode; variable baud rate, $fx/(16 \times (16\text{bit BRDATA}+1))$
- 9-bit UART mode; variable baud rate, $fx/(16 \times (16\text{bit BRDATA}+1))$

UART receive and transmit buffers are both accessed via the data register, UDATA, is at address F5H. Writing to the UART data register loads the transmit buffer; reading the UART data register accesses a physically separate receive buffer.

When accessing a receive data buffer (shift register), reception of the next byte can begin before the previously received byte has been read from the receive register. However, if the first byte has not been read by the time the next byte has been completely received, the first data byte will be lost (Overrun error).

In all operating modes, transmission is started when any instruction (usually a write operation) uses the UDATA register as its destination address. In mode 0, serial data reception starts when the receive interrupt pending bit (UARTPND.1) is "0" and the receive enable bit (UARTCON.4) is "1". In mode 1 and 2, reception starts whenever an incoming start bit ("0") is received and the receive enable bit (UARTCON.4) is set to "1".

PROGRAMMING PROCEDURE

To program the UART modules, follow these basic steps:

1. Configure P2.6 and P2.7 to alternative function (RXD (P2.6), TXD (P2.7)) for UART module by setting the P1CONH register to appropriate value.
2. Load an 8-bit value to the UARTCON control register to properly configure the UART I/O module.
3. For parity generation and check in UART mode 2, set parity enable bit (UARTPND.5) to "1".
4. For interrupt generation, set the UART interrupt enable bit (UARTCON.1 or UARTCON.0) to "1".
5. When you transmit data to the UART buffer, write transmit data to UDATA, the shift operation starts.
6. When the shift operation (transmit/receive) is completed, UART pending bit (UARTPND.1 or UARTPND.0) is set to "1" and an UART interrupt request is generated.

UART CONTROL REGISTER (UARTCON)

The control register for the UART is called UARTCON at address F6H. It has the following control functions:

- Operating mode and baud rate selection
- Multiprocessor communication and interrupt control
- Serial receive enable/disable control
- 9th data bit location for transmit and receive operations (mode 2)
- Parity generation and check for transmit and receive operations (mode 2)
- UART transmit and receive interrupt control

A reset clears the UARTCON value to "00H". So, if you want to use UART module, you must write appropriate value to UARTCON.

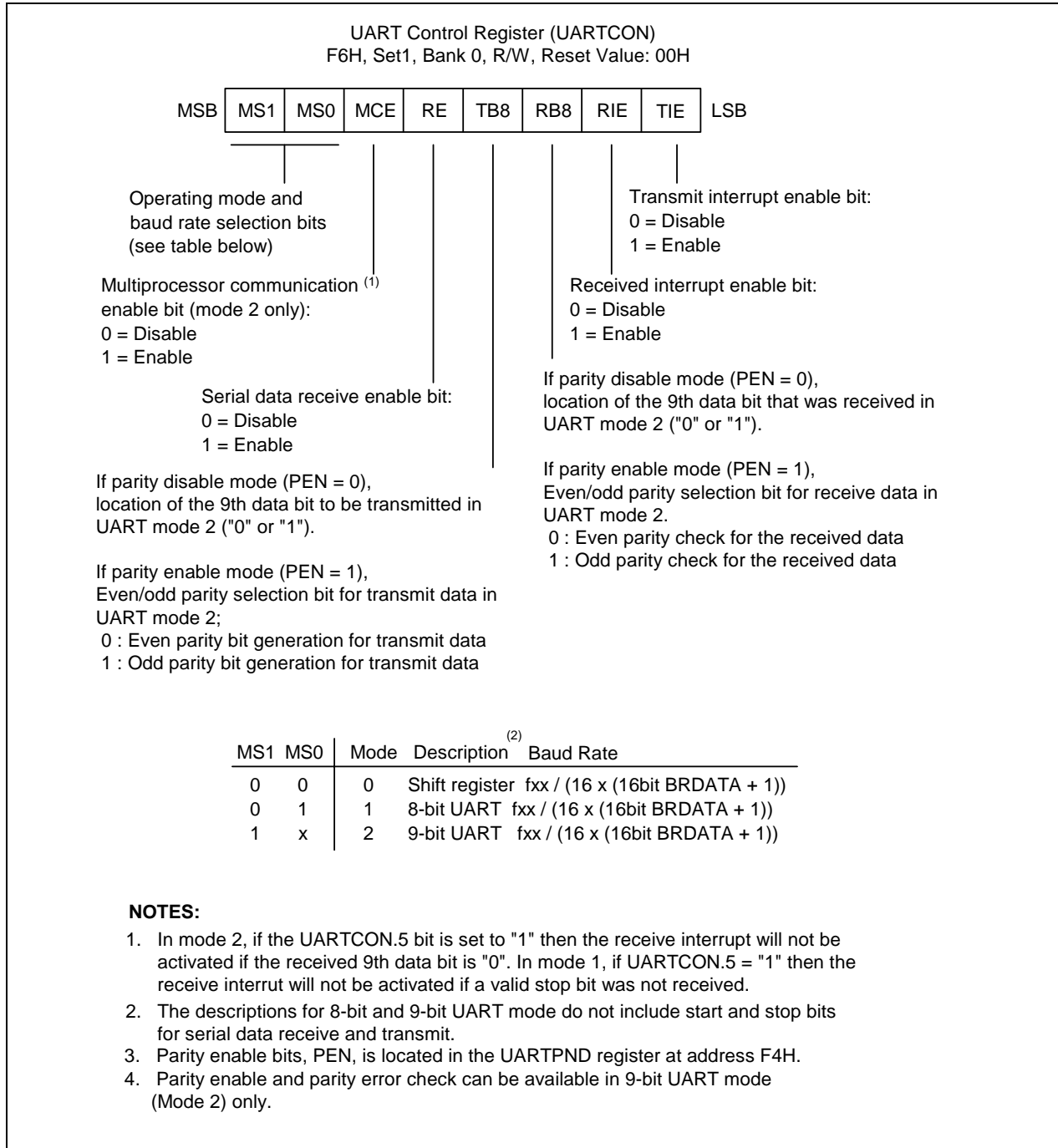


Figure 15-1. UART Control Register (UARTCON)

UART INTERRUPT PENDING REGISTER (UARTPND)

The UART interrupt pending register, UARTPND is located at address F4H. It contains the UART data transmit interrupt pending bit (UARTPND.0) and the receive interrupt pending bit (UARTPND.1).

In mode 0 of the UART module, the receive interrupt pending flag UARTPND.1 is set to "1" when the 8th receive data bit has been shifted. In mode 1 or 2, the UARTPND.1 bit is set to "1" at the halfway point of the stop bit's shift time. When the CPU has acknowledged the receive interrupt pending condition, the UARTPND.1 flag must be cleared by software in the interrupt service routine.

In mode 0 of the UART module, the transmit interrupt pending flag UARTPND.0 is set to "1" when the 8th transmit data bit has been shifted. In mode 1 or 2, the UARTPND.0 bit is set at the start of the stop bit. When the CPU has acknowledged the transmit interrupt pending condition, the UARTPND.0 flag must be cleared by software in the interrupt service routine.

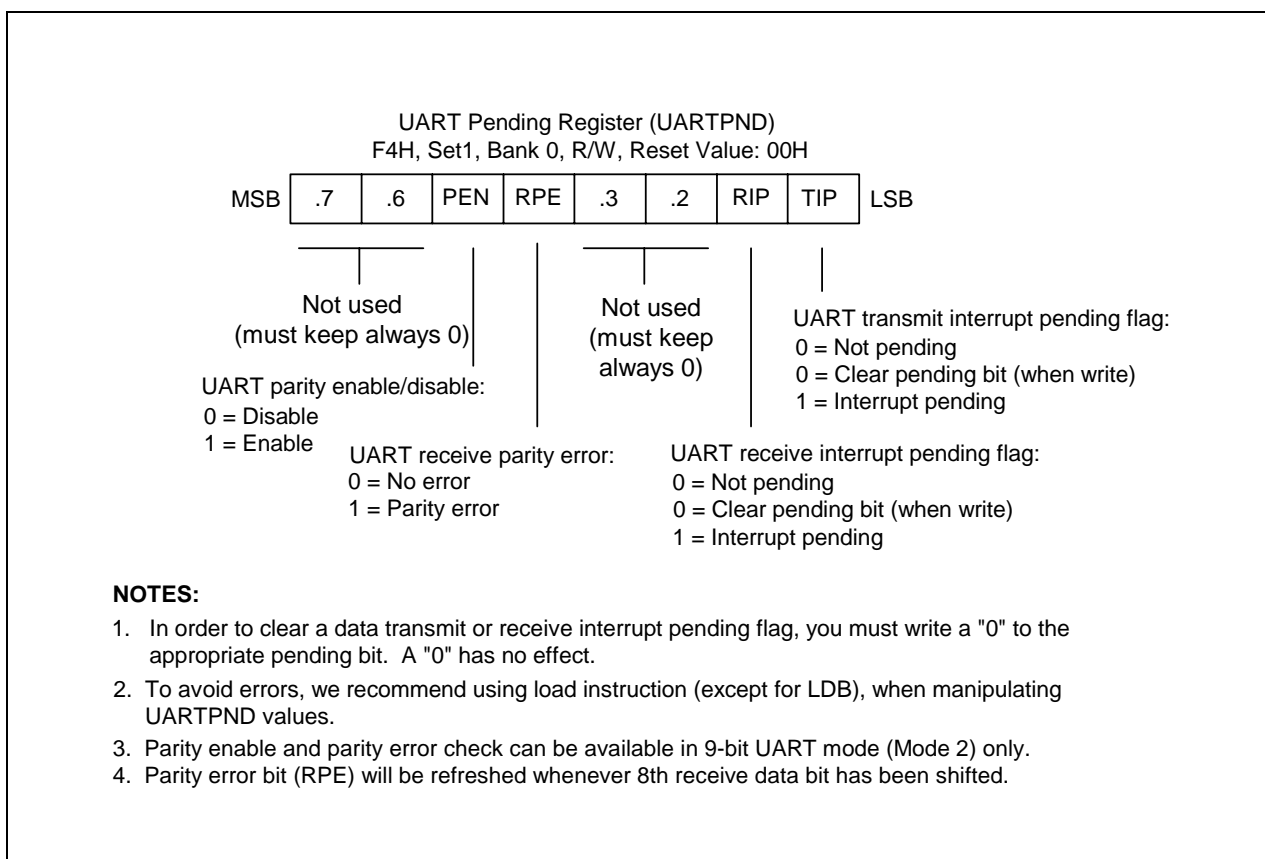


Figure 15-2. UART Interrupt Pending Register (UARTPND)

In mode 2 (9-bit UART data), by setting the parity enable bit (PEN) of UARTPND register to '1', the 9th data bit of transmit data will be an automatically generated parity bit. Also, the 9th data bit of the received data will be treated as a parity bit for checking the received data.

In parity enable mode (PEN = 1), UARTCON.3 (TB8) and UARTCON.2 (RB8) will be a parity selection bit for transmit and receive data respectively. The UARTCON.3 (TB8) is for settings of the even parity generation (TB8 = 0) or the odd parity generation (TB8 = 1) in the transmit mode. The UARTCON.2 (RB8) is also for settings of the even parity checking (RB8 = 0) or the odd parity checking (RB8 = 1) in the receive mode. The parity enable (generation/checking) functions are not available in UART mode 0 and 1.

If you don't want to use a parity mode, UARTCON.2 (RB8) and UARTCON.3 (TB8) are a normal control bit as the 9th data bit, in this case, PEN must be disable ("0") in mode 2. Also it is needed to select the 9th data bit to be transmitted by writing TB8 to "0" or "1".

The receive parity error flag (RPE) will be set to '0' or '1' depending on parity error whenever the 8th data bit of the receive data has been shifted.

UART DATA REGISTER (UDATA)

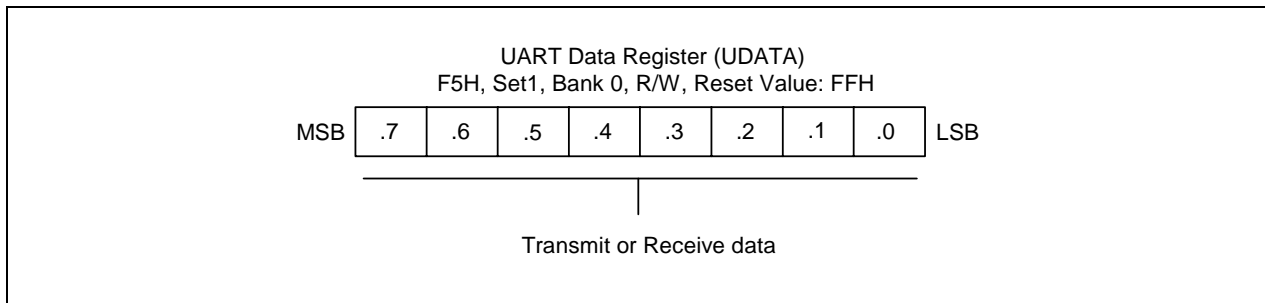


Figure 15-3. UART Data Register (UDATA)

UART BAUD RATE DATA REGISTER (BRDATAH, BRDATAL)

The value stored in the UART baud rate register, (BRDATAH, BRDATAL), lets you determine the UART clock rate (baud rate).

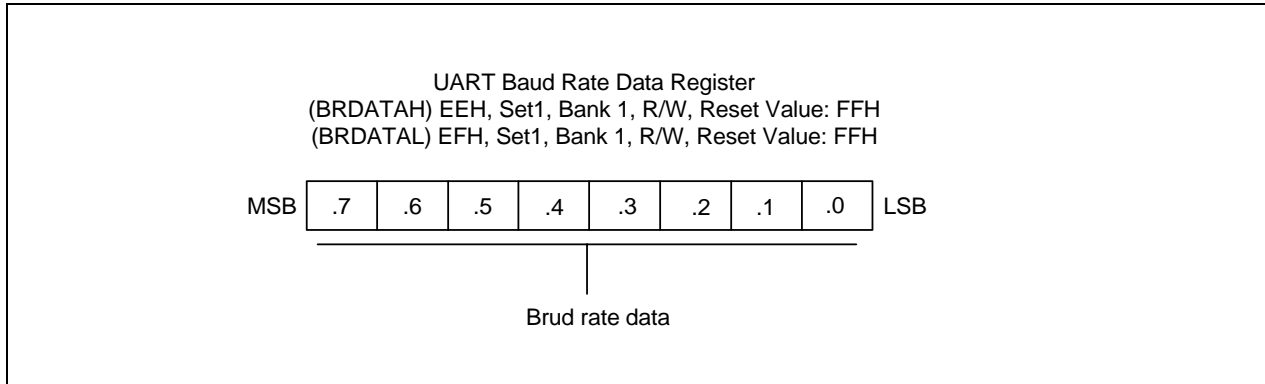


Figure 15-4. UART Baud Rate Data Register (BRDATAH, BRDATAL)

BAUD RATE CALCULATIONS

The baud rate is determined by the baud rate data register, 16bit BRDATA

$$\text{Mode 0 baud rate} = f_{xx} / (16 \times (16\text{Bit BRDATA} + 1))$$

$$\text{Mode 1 baud rate} = f_{xx} / (16 \times (16\text{Bit BRDATA} + 1))$$

$$\text{Mode 2 baud rate} = f_{xx} / (16 \times (16\text{Bit BRDATA} + 1))$$

Table 15-1. Commonly Used Baud Rates Generated by 16bit BRDATA

Baud Rate	Oscillation Clock	BRDATAH		BRDATAL	
		Decimal	Hex	Decimal	Hex
230,400 Hz	11.0592 MHz	0	0H	02	02H
115,200 Hz	11.0592 MHz	0	0H	05	05H
57,600 Hz	11.0592 MHz	0	0H	11	0BH
38,400 Hz	11.0592 MHz	0	0H	17	11H
19,200 Hz	11.0592 MHz	0	0H	35	23H
9,600 Hz	11.0592 MHz	0	0H	71	47H
4,800 Hz	11.0592 MHz	0	0H	143	8FH
76,800 Hz	10 MHz	0	0H	7	7H
38,400 Hz	10 MHz	0	0H	15	FH
19,200 Hz	10 MHz	0	0H	31	1FH
9,600 Hz	10 MHz	0	0H	64	40H
4,800 Hz	10 MHz	0	0H	129	81H
2,400 Hz	10 MHz	1	1H	3	3H
600 Hz	10 MHz	4	4H	16	10H
38,461 Hz	8 MHz	0	0H	12	0CH
12,500 Hz	8 MHz	0	0H	39	27H
19,230 Hz	4 MHz	0	0H	12	0CH
9,615 Hz	4 MHz	0	0H	25	19H

BLOCK DIAGRAM

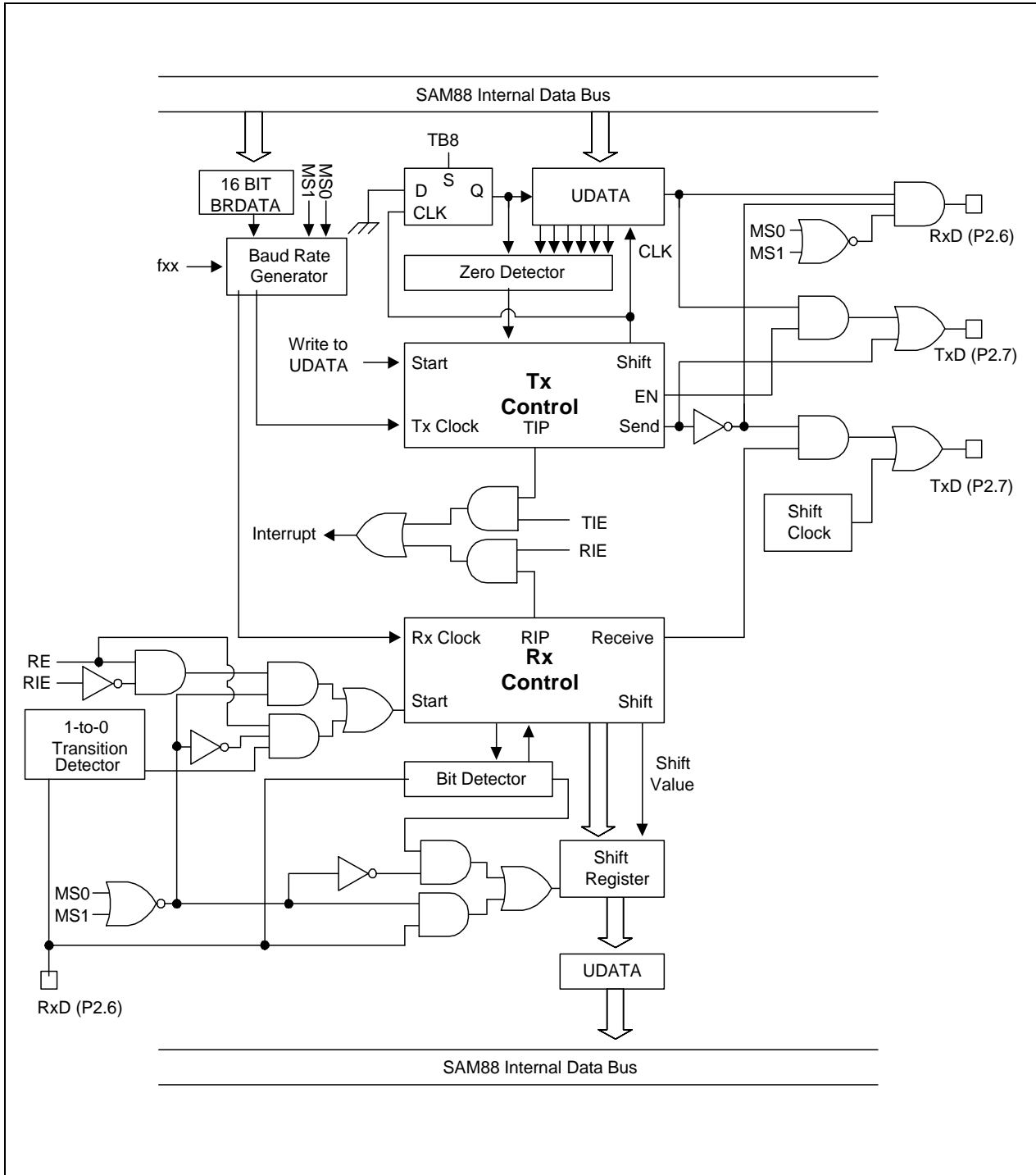


Figure 15-5. UART Functional Block Diagram

UART MODE 0 FUNCTION DESCRIPTION

In mode 0, UART is input and output through the RxD (P2.6) pin and TxD (P2.7) pin outputs the shift clock. Data is transmitted or received in 8-bit units only. The LSB of the 8-bit value is transmitted (or received) first.

Mode 0 Transmit Procedure

1. Select mode 0 by setting UARTCON.6 and .7 to "00B".
2. Write transmission data to the shift register UDATA (F5H) to start the transmission operation.

Mode 0 Receive Procedure

1. Select mode 0 by setting UATCON.6 and .7 to "00B".
2. Clear the receive interrupt pending bit (UARTPND.1) by writing a "0" to UARTPND.1.
3. Set the UART receive enable bit (UARTCON.4) to "1".
4. The shift clock will now be output to the TxD (P2.7) pin and will read the data at the RxD (P2.6) pin. A UART receive interrupt (vector E4H) occurs when UARTCON.1 is set to "1".

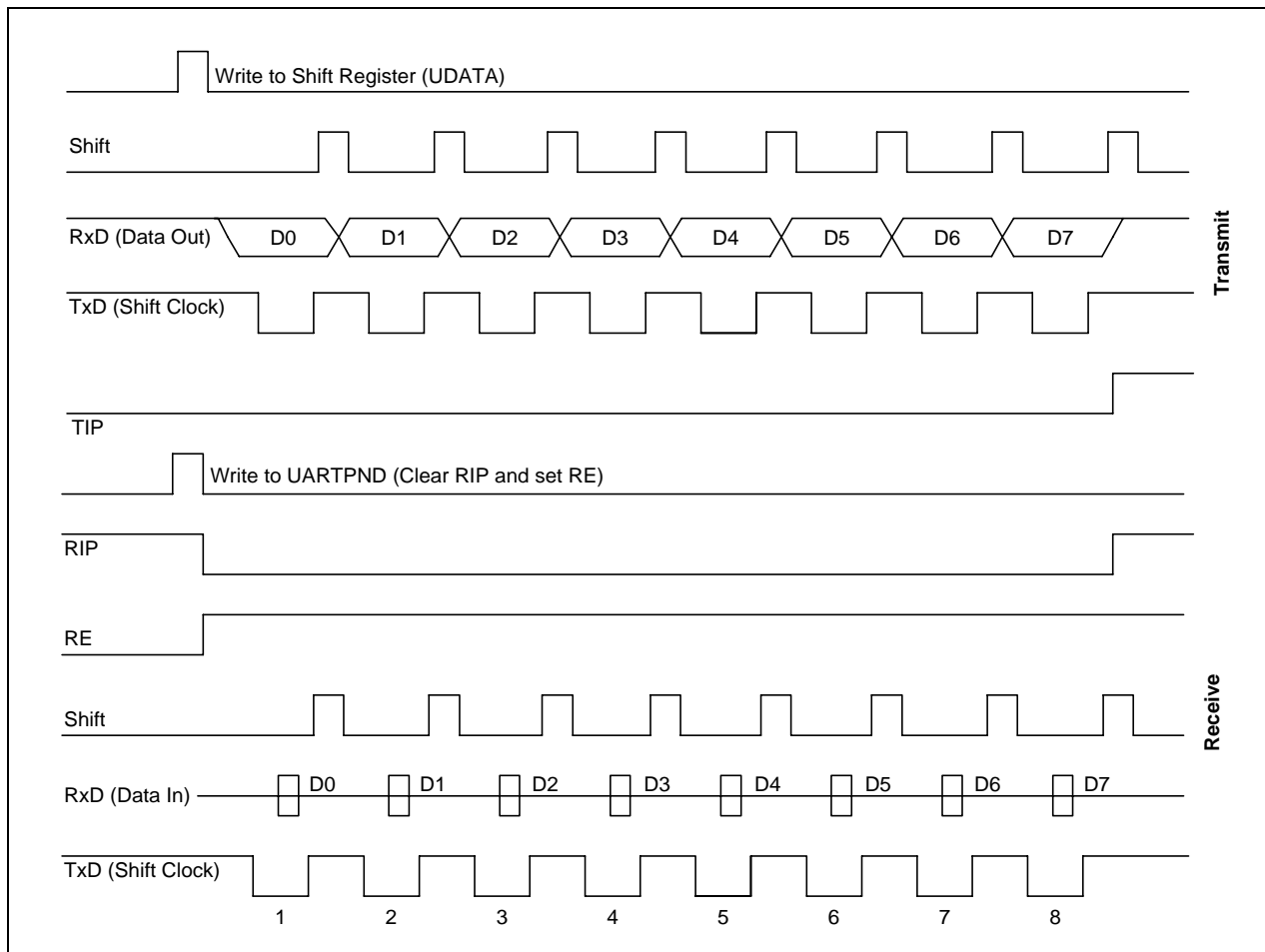


Figure 15-6. Timing Diagram for UART Mode 0 Operation

UART MODE 1 FUNCTION DESCRIPTION

In mode 1, 10-bits are transmitted (through the TxD (P2.7) pin) or received (through the RxD (P2.6) pin). Each data frame has three components:

- Start bit ("0")
- 8 data bits (LSB first)
- Stop bit ("1")

When receiving, the stop bit is written to the RB8 bit in the UARTCON register. The baud rate for mode 1 is variable.

Mode 1 Transmit Procedure

1. Select the baud rate generated by 16bit BRDATA.
2. Select mode 1 (8-bit UART) by setting UARTCON bits 7 and 6 to '01B'.
3. Write transmission data to the shift register UDATA (F5H). The start and stop bits are generated automatically by hardware.

Mode 1 Receive Procedure

1. Select the baud rate to be generated by 16bit BRDATA.
2. Select mode 1 and set the RE (Receive Enable) bit in the UARTCON register to "1".
3. The start bit low ("0") condition at the RxD (P1.4) pin will cause the UART module to start the serial data receive operation.

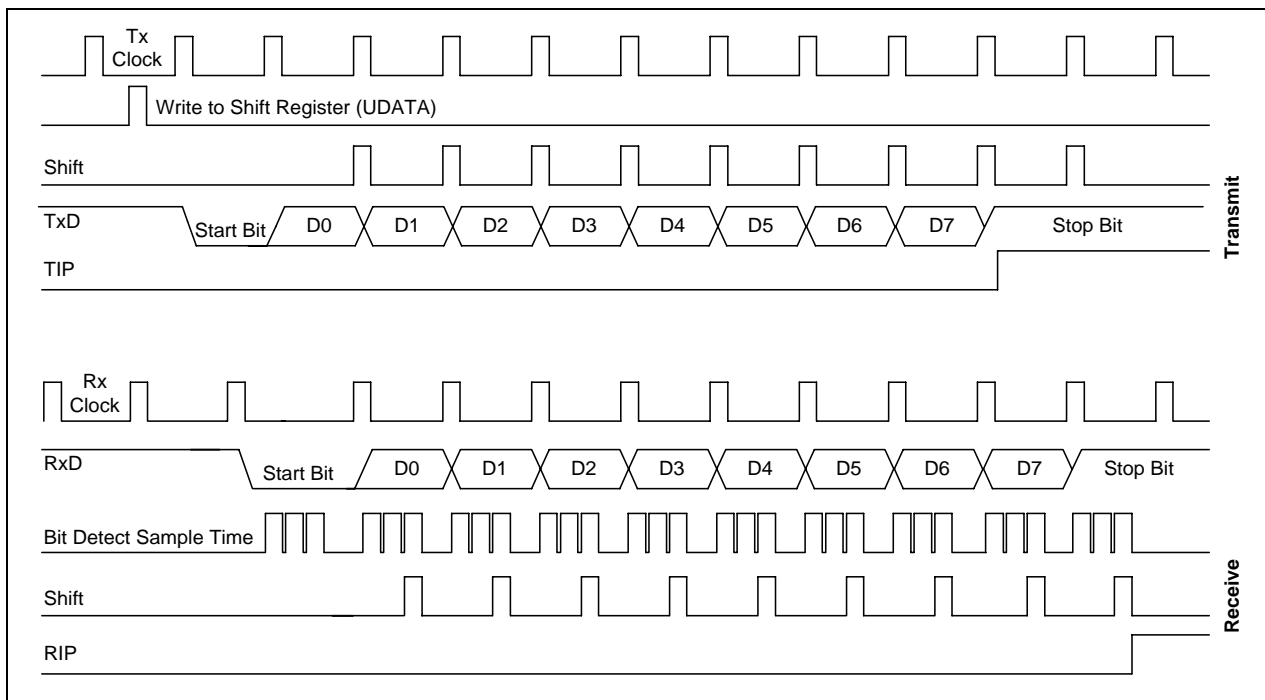


Figure 15-7. Timing Diagram for UART Mode 1 Operation

UART MODE 2 FUNCTION DESCRIPTION

In mode 2, 11-bits are transmitted (through the TxD pin) or received (through the RxD pin). Each data frame has four components:

- Start bit ("0")
- 8 data bits (LSB first)
- Programmable 9th data bit or parity bit
- Stop bit ("1")

< In parity disable mode (PEN = 0) >

The 9th data bit to be transmitted can be assigned a value of "0" or "1" by writing the TB8 bit (UARTCON.3). When receiving, the 9th data bit that is received is written to the RB8 bit (UARTCON.2), while the stop bit is ignored. The baud rate for mode 2 is $f_{osc}/(16 \times (16\text{bit BRDATA} + 1))$ clock frequency.

< In parity enable mode (PEN = 1) >

The 9th data bit to be transmitted can be an automatically generated parity of "0" or "1" depending on a parity generation by means of TB8 bit (UARTCON.3). When receiving, the received 9th data bit is treated as a parity for checking receive data by means of the RB8 bit (UARTCON.2), while the stop bit is ignored. The baud rate for mode 2 is $f_{osc}/(16 \times (16\text{bit BRDATA} + 1))$ clock frequency.

Mode 2 Transmit Procedure

1. Select the baud rate generated by 16bit BRDATA.
2. Select mode 2 (9-bit UART) by setting UARTCON bits 6 and 7 to '10B'. Also, select the 9th data bit to be transmitted by writing TB8 to "0" or "1" and set PEN bit of UARTPND register to "0" if you don't use a parity mode. If you want to use the parity enable mode, select the parity bit to be transmitted by writing TB8 to "0" or "1" and set PEN bit of UARTPND register to "1".
3. Write transmission data to the shift register, UDATA (F5H), to start the transmit operation.

Mode 2 Receive Procedure

1. Select the baud rate to be generated by 16bit BRDATA.
2. Select mode 2 and set the receive enable bit (RE) in the UARTCON register to "1".
3. If you don't use a parity mode, set PEN bit of UARTPND register to "0" to disable parity mode. If you want to use the parity enable mode, select the parity type to be check by writing TB8 to "0" or "1" and set PEN bit of UARTPND register to "1". Only 8 bits (Bit0 to Bit7) of received data are available for data value.
4. The receive operation starts when the signal at the RxD pin goes to low level.

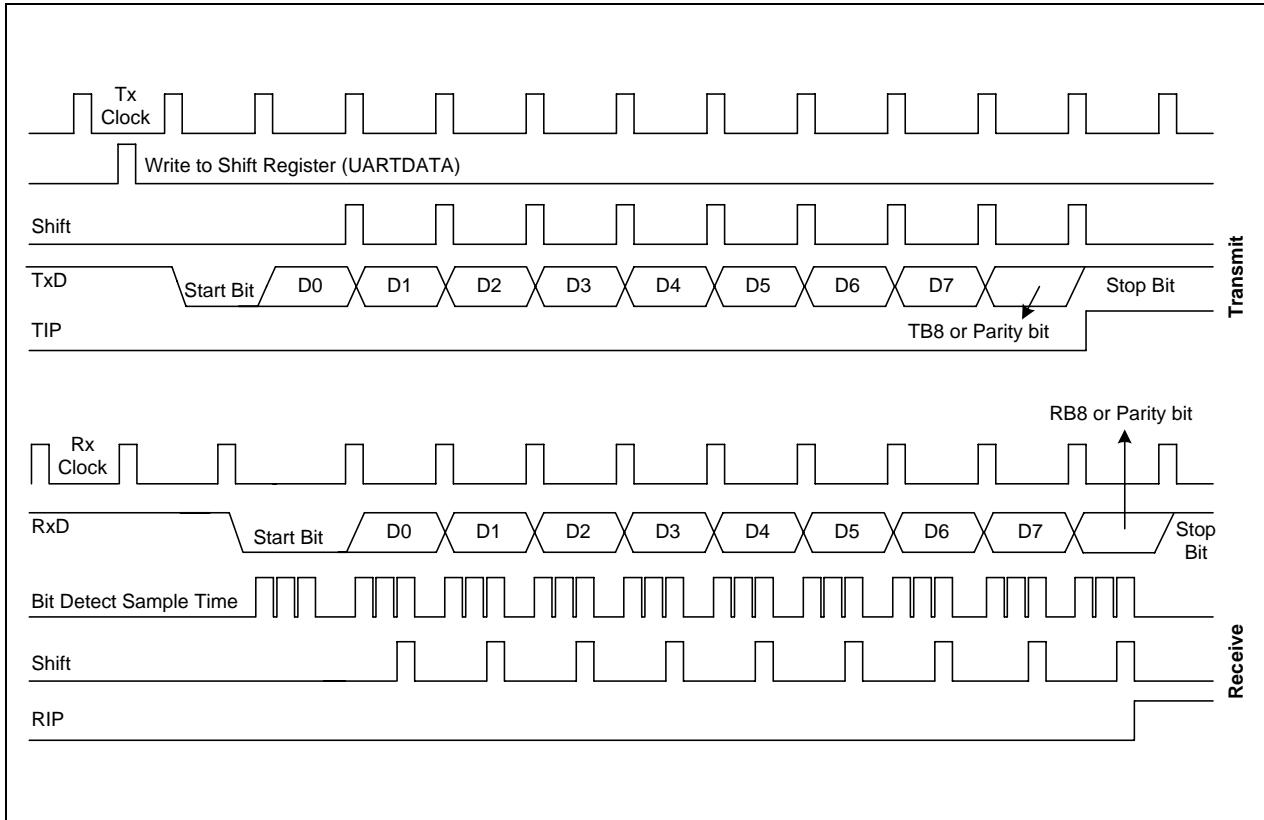


Figure 15-8. Timing Diagram for UART Mode 2 Operation

SERIAL COMMUNICATION FOR MULTIPROCESSOR CONFIGURATIONS

The S3C9-series multiprocessor communication features let a "master" S3C84H5/F84H5 send a multiple-frame serial message to a "slave" device in a multi- S3C84H5/F84H5 configuration. It does this without interrupting other slave devices that may be on the same serial line.

This feature can be used only in UART mode 2 with the parity disable mode. In mode 2, 9 data bits are received. The 9th bit value is written to RB8 (UARTCON.2). The data receive operation is concluded with a stop bit. You can program this function so that when the stop bit is received, the serial interrupt will be generated only if RB8 = "1".

To enable this feature, you set the MCE bit in the UARTCON registers. When the MCE bit is "1", serial data frames that are received with the 9th bit = "0" do not generate an interrupt. In this case, the 9th bit simply separates the address from the serial data.

Sample Protocol for Master/Slave Interaction

When the master device wants to transmit a block of data to one of several slaves on a serial line, it first sends out an address byte to identify the target slave. Note that in this case, an address byte differs from a data byte: In an address byte, the 9th bit is "1" and in a data byte, it is "0".

The address byte interrupts all slaves so that each slave can examine the received byte and see if it is being addressed. The addressed slave then clears its MCE bit and prepares to receive incoming data bytes.

The MCE bits of slaves that were not addressed remain set, and they continue operating normally while ignoring the incoming data bytes.

While the MCE bit setting has no effect in mode 0, it can be used in mode 1 to check the validity of the stop bit. For mode 1 reception, if MCE is "1", the receive interrupt will be issue unless a valid stop bit is received.

Setup Procedure for Multiprocessor Communications

Follow these steps to configure multiprocessor communications:

1. Set all S3C84H5/F84H5 devices (masters and slaves) to UART mode 2 with parity disable.
2. Write the MCE bit of all the slave devices to "1".
3. The master device's transmission protocol is:
 - First byte: the address identifying the target slave device (9th bit = "1")
 - Next bytes: data (9th bit = "0")
4. When the target slave receives the first byte, all of the slaves are interrupted because the 9th data bit is "1". The targeted slave compares the address byte to its own address and then clears its MCE bit in order to receive incoming data. The other slaves continue operating normally.

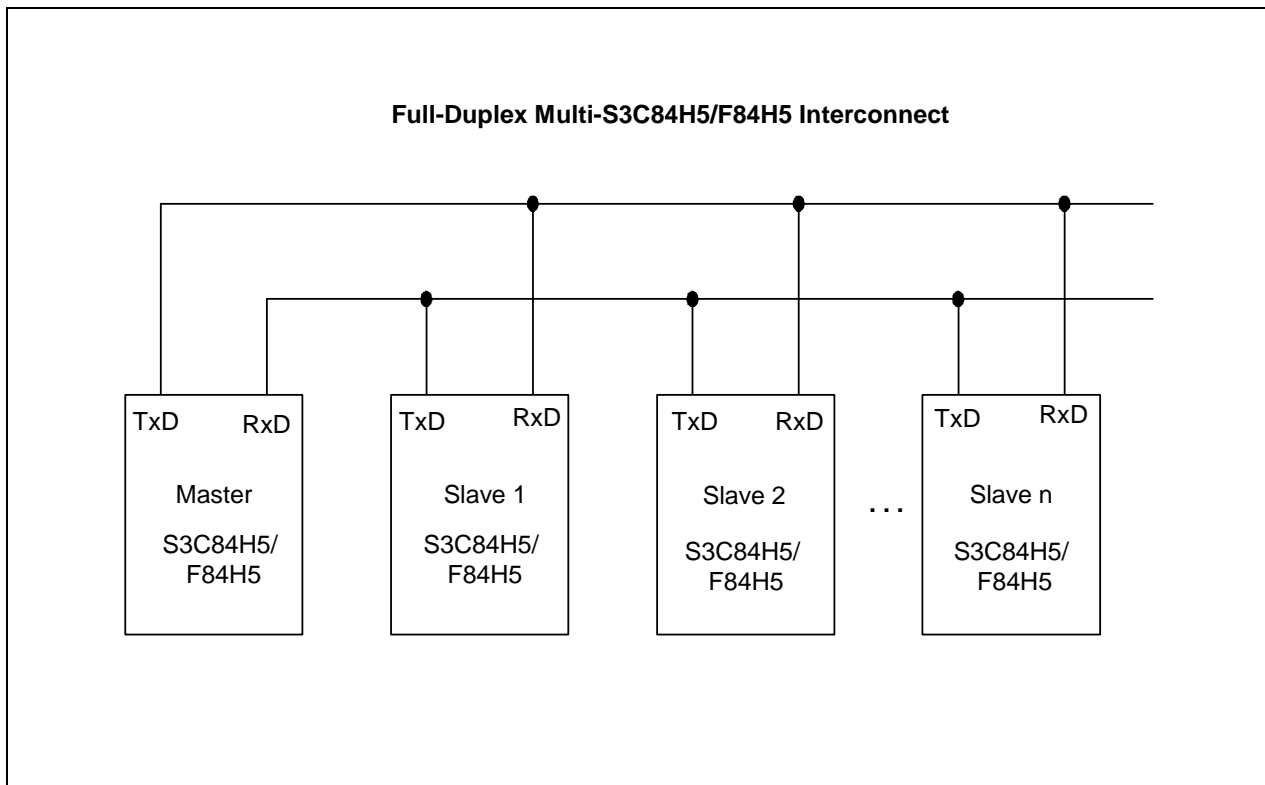


Figure 15-9. Connection Example for Multiprocessor Serial Data Communications

16

A/D CONVERTER

OVERVIEW

The 10-bit A/D converter (ADC) module uses successive approximation logic to convert analog levels entering at one of the eight input channels to equivalent 10-bit digital values. The analog input level must lie between the AV_{REF} and AV_{SS} values. The A/D converter has the following components:

- Analog comparator with successive approximation logic
- D/A converter logic (resistor string type)
- ADC control register, ADCON (set 1, bank 0, F7H, read/write, but ADCON.3 is read only)
- Eight multiplexed analog data input pins (ADC0–ADC7)
- 10-bit A/D conversion data output register (ADDATAH, ADDATAL)

FUNCTION DESCRIPTION

To initiate an analog-to-digital conversion procedure, at first, you must configure P0.0–P0.3, P2.2–P2.3, P1.4–P1.5 to analog input before A/D conversions because the P0.0–P0.3, P2.2–P2.3, P1.4–P1.5 pins can be used alternatively as normal data I/O or analog input pins. To do this, you load the appropriate value to the P0CONL, P2CONL and P1CONH (for ADC0–ADC7) register.

And you write the channel selection data in the A/D converter control register ADCON to select one of the eight analog input pins (ADC_n , $n = 0-7$) and set the conversion start or enable bit, ADCON.0. A 10-bit conversion operation can be performed for only one analog input channel at a time. The read-write ADCON register is located in set 1, bank 0 at address F7H.

During a normal conversion, ADC logic initially sets the successive approximation register to 200H (the approximate half-way point of an 10-bit register). This register is then updated automatically during each conversion step. The successive approximation block performs 10-bit conversions for one input channel at a time. You can dynamically select different channels by manipulating the channel selection bit value (ADCON.6–.4) in the ADCON register.

To start the A/D conversion, you should set the enable bit, ADCON.0. When a conversion is completed, ADCON.3, the end-of-conversion (EOC) bit is automatically set to 1 and the result is dumped into the ADDATAH, ADDATAL registers where it can be read. The ADC module enters an idle state. Remember to read the contents of ADDATAH and ADDATAL before another conversion starts. Otherwise, the previous result will be overwritten by the next conversion result.

NOTE

Because the ADC does not use sample-and-hold circuitry, it is important that any fluctuations in the analog level at the ADC0–ADC7 input pins during a conversion procedure be kept to an absolute minimum. Any change in the input level, perhaps due to circuit noise, will invalidate the result.

A/D CONVERTER CONTROL REGISTER (ADCON)

The A/D converter control register, ADCON, is located in set1, bank 0 at address F7H. ADCON is read-write addressable using 8-bit instructions only. But, the EOC bit, ADCON.3 is read only. ADCON has four functions:

- Bits 6–4 select an analog input pin (ADC0–ADC7).
- Bit 3 indicates the end of conversion status of the A/D conversion.
- Bits 2–1 select a conversion speed.
- Bit 0 starts the A/D conversion.

Only one analog input channel can be selected at a time. You can dynamically select any one of the eight analog input pins, ADC0–ADC7 by manipulating the 3-bit value for ADCON.6–ADCON.4

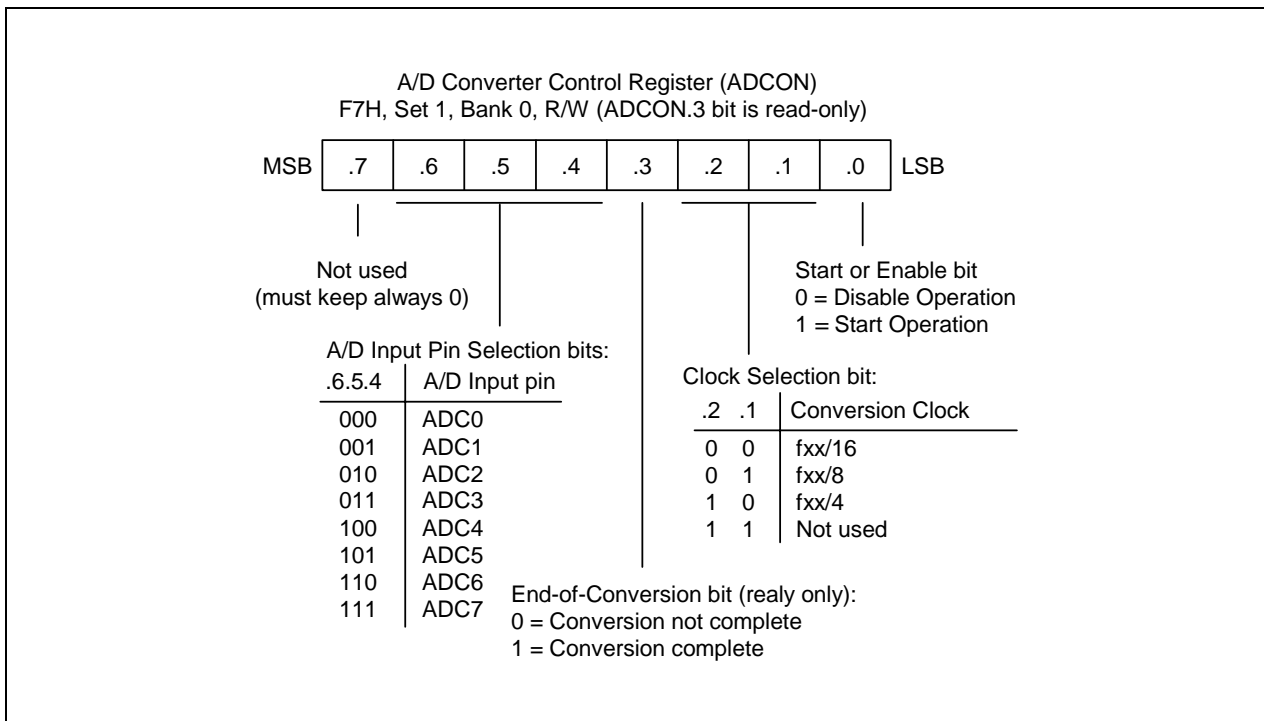


Figure 16-1. A/D Converter Control Register (ADCON)

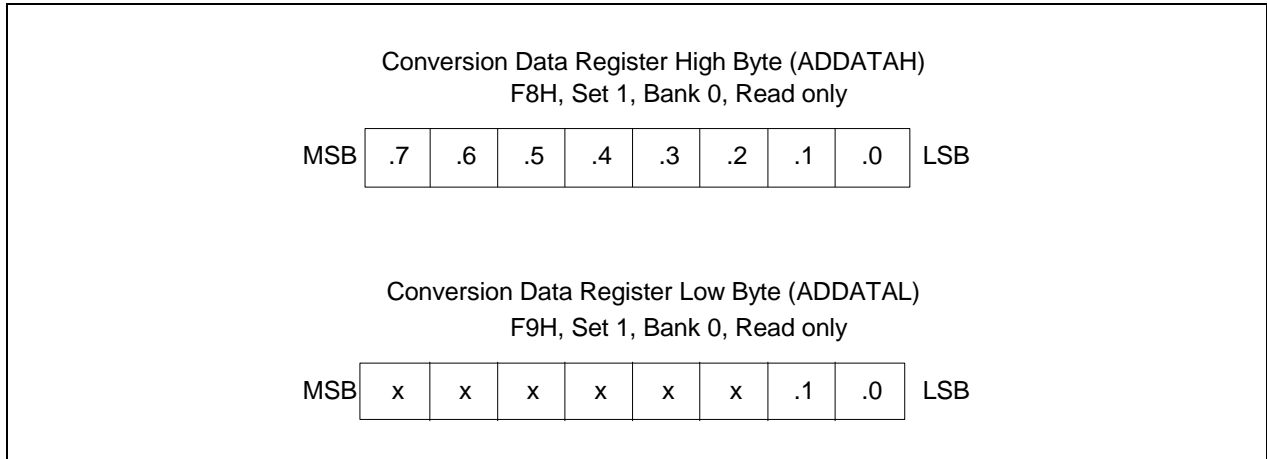


Figure 16-2. A/D Converter Data Register (ADDATAH, ADDATAL)

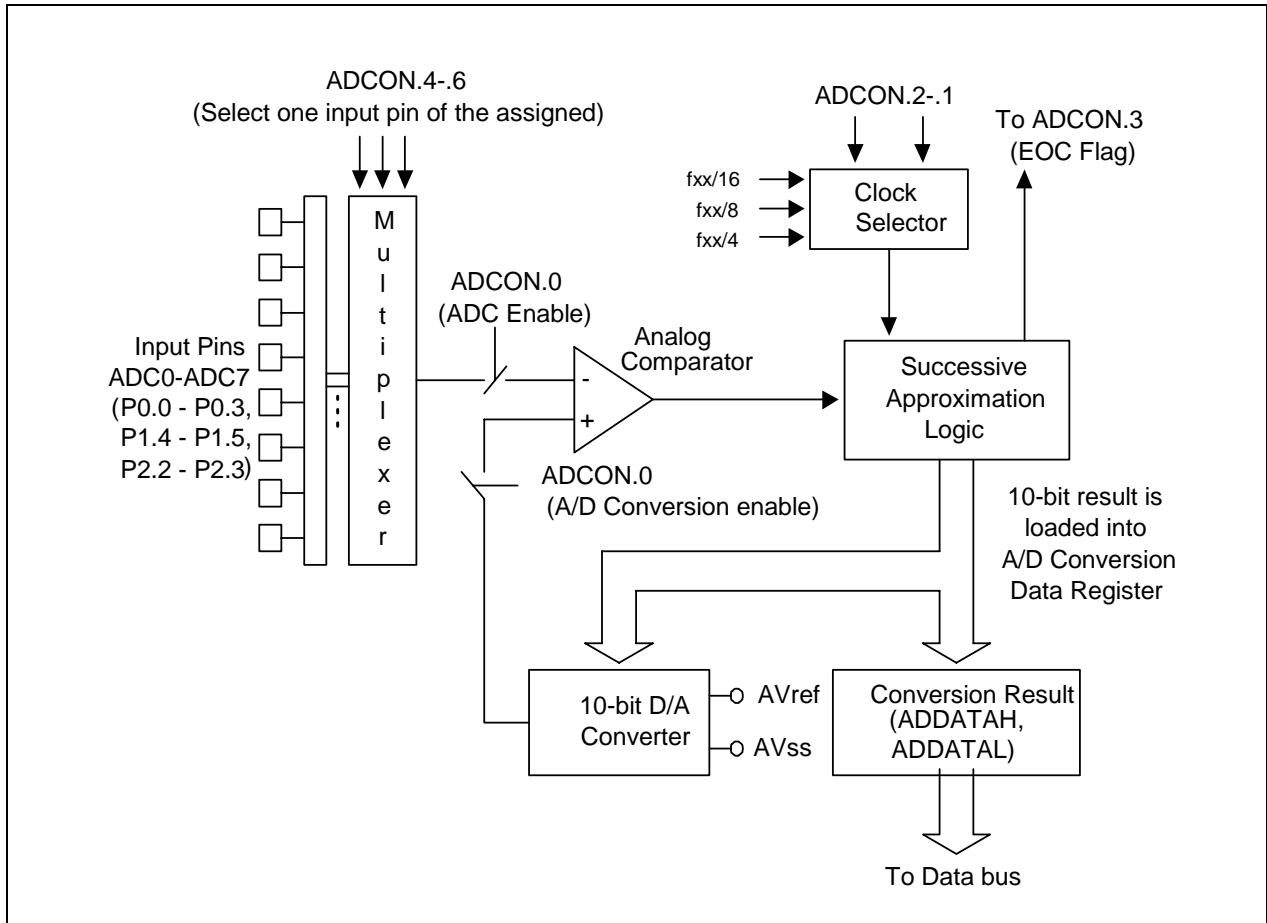


Figure 16-3. A/D Converter Circuit Diagram

INTERNAL REFERENCE VOLTAGE LEVELS

In the ADC function block, the analog input voltage level is compared to the reference voltage. The analog input level must remain within the range AV_{SS} to AV_{REF} ($AV_{REF} = V_{DD}$).

Different reference voltage levels are generated internally along the resistor tree during the analog conversion process for each conversion step. The reference voltage level for the first bit conversion is always $1/2 AV_{REF}$.

CONVERSION TIMING

The A/D conversion process requires 4 steps (4 clock edges) to convert each bit and 10 clocks to step-up A/D conversion. Therefore, total of 50 clocks is required to complete a 10-bit conversion: With a 10 MHz CPU clock frequency, one clock cycle is 400 ns ($4/f_{xx}$). If each bit conversion requires 4 clocks, the conversion rate is calculated as follows:

$$4 \text{ clocks/bit} \times 10\text{-bits} + \text{step-up time (10 clock)} = 50 \text{ clocks}$$

$$50 \text{ clock} \times 400 \text{ ns} = 20 \mu\text{s at } 10 \text{ MHz, } 1 \text{ clock time} = 4/f_{xx}$$

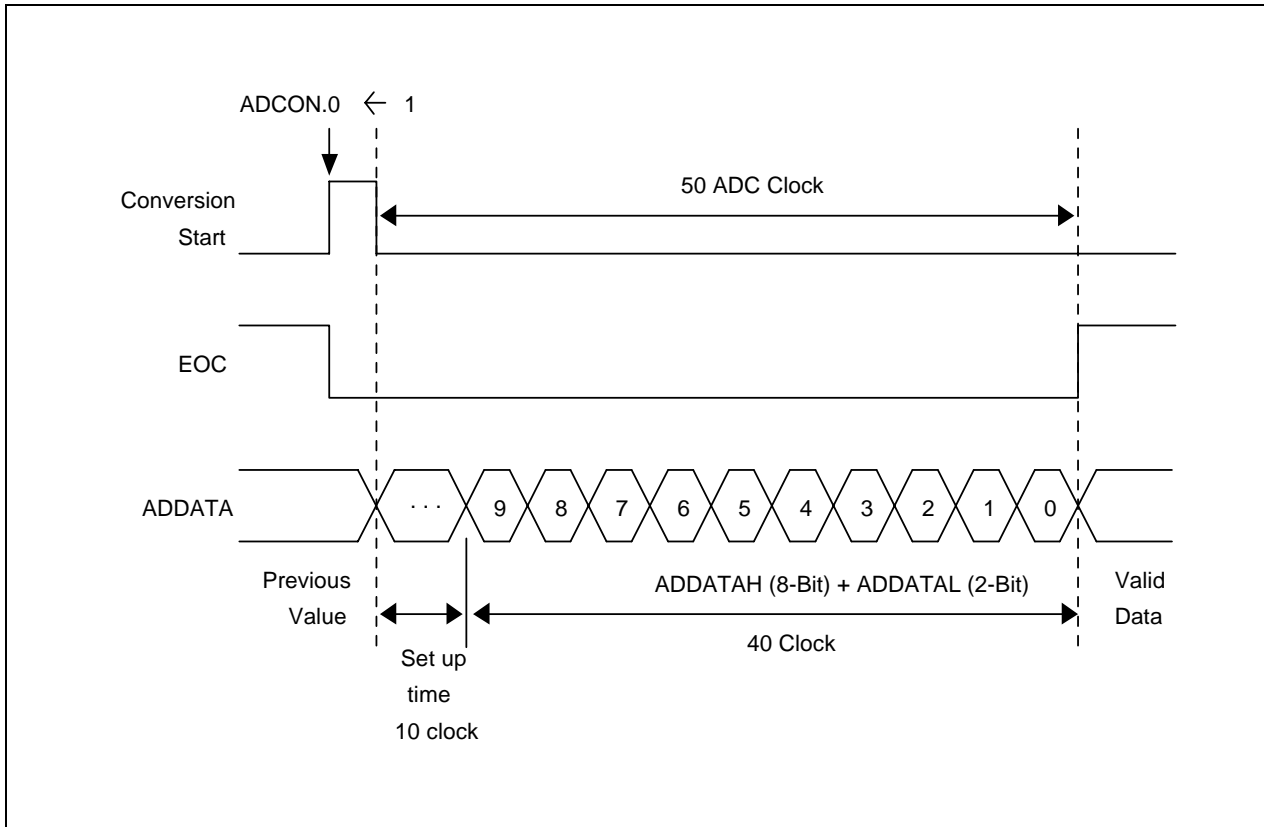


Figure 16-4. A/D Converter Timing Diagram

INTERNAL A/D CONVERSION PROCEDURE

1. Analog input must remain between the voltage range of AV_{SS} and AV_{REF} .
2. Configure P0.0 – P0.3, P1.4 – P1.5, P2.2 – P2.3 for analog input before A/D conversions. To do this, you load the appropriate value to the P0CONL, P1CONH and P2CONL (for ADC0–ADC7) registers.
3. Before the conversion operation starts, you must first select one of the eight input pins (ADC0–ADC7) by writing the appropriate value to the ADCON register.
4. When conversion has been completed, (50 clocks have elapsed), the EOC, ADCON.3 flag is set to "1", so that a check can be made to verify that the conversion was successful.
5. The converted digital value is loaded to the output register, ADDATAH (8-bit) and ADDATAL (2-bit), then the ADC module enters an idle state.
6. The digital conversion result can now be read from the ADDATAH and ADDATAL register.

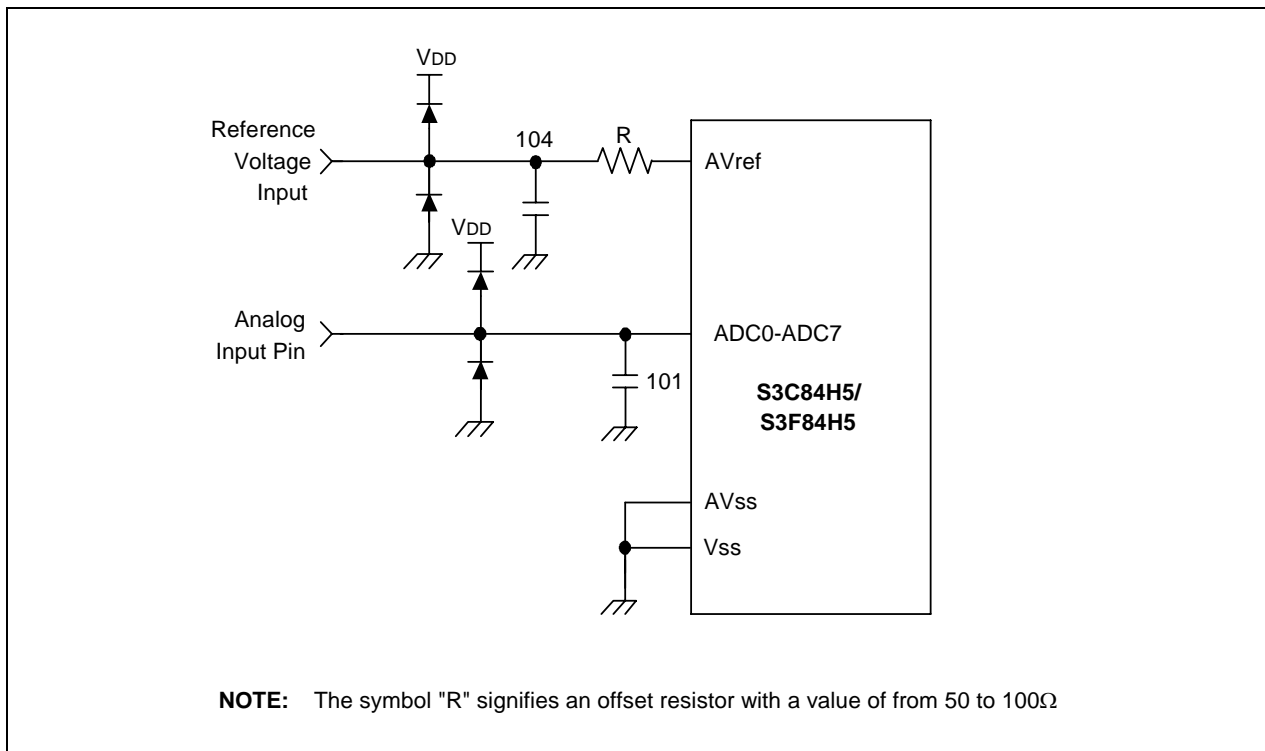



Figure 16-5. Recommended A/D Converter Circuit for Highest Absolute Accuracy

 **PROGRAMMING TIP — Configuring A/D Converter**

```

•
SB1                ; Extra command only for debugging (note)
LD      0F7H,#5FH  ; Extra command only for debugging (note)
SB0                ; Extra command only for debugging (note)
•
•
LD      P0CON, #11111111B ; P0.0–P0.3 A/D Input MODE
LD      P1CONH, #00001111B ; P1.4–P1.5 A/D Input MODE
LD      P2CONL, #111110000B ; P2.2–P2.3 A/D Input MODE
•
•
AD0_CHK: LD      ADCON, #00000001B ; Channel ADC0, fxx, Conversion start
          TM      ADCON, #00001000B ; A/D conversion end ? → EOC check
          JR      Z, AD0_CHK        ; No
          LD      AD0BUFH, ADDATAH ; 8-bit Conversion data
          LD      AD0BUFL, ADDATAL ; 2-bit Conversion data
          •
          •
AD3_CHK: LD      ADCON, #00110001B ; Channel ADC3, fxx, Conversion start
          TM      ADCON, #00001000B ; A/D conversion end ? → EOC check
          JR      Z, AD3_CHK        ; No
          LD      AD3BUFH, ADDATAH ; 8-bit Conversion data
          LD      AD3BUFL, ADDATAL ; 2-bit Conversion data
          •
          •

```

NOTE: In debug mode, you have to include three extra commands in initial routine to operate Ports correctly. If you omit these commands, Port do not operate correctly. After you have finished your program and before assembling, you have to remove these three commands.

17

WATCH TIMER

OVERVIEW

Watch timer functions include real-time and watch-time measurement and interval timing for the system clock. To start watch timer operation, set bit1 and bit 6 of the watch timer mode register, WTCON.1 and 6, to "1". After the watch timer starts and elapses a time, the watch timer interrupt is automatically set to "1", and interrupt requests commence in 1.955 ms or 0.125, 0.25 and 0.5-second intervals.

The watch timer can generate a steady 0.5 kHz, 1 kHz, 2 kHz, or 4 kHz signal to the BUZZER output (BZOUT pin). By setting WTCON.3 and WTCON.2 to "11b", the watch timer will function in high-speed mode, generating an interrupt every 1.955 ms. High-speed mode is useful for timing events for program debugging sequences.

- Real-time and Watch-time measurement
- Using a main system or subsystem clock source
- Buzzer output frequency generator
- Timing tests in high-speed mode

WATCH TIMER CONTROL REGISTER (WTCON: R/W)

F8H	WTCON.7	WTCON.6	WTCON.5	WTCON.4	WTCON.3	WTCON.2	WTCON.1	WTCON.0
RESET	"0"	"0"	"0"	"0"	"0"	"0"	"0"	"0"

Table 17-1. Watch Timer Control Register (WTCON): Set 1, Bank 1, F8H, R/W

Bit Name	Values	Function	Address	
WTCON.7	0	Select (fx/256) as the watch timer clock (fx: Main clock)	F8H	
	1	Select subsystem clock as watch timer clock		
WTCON.6	0	Disable watch timer interrupt		
	1	Enable watch timer interrupt		
WTCON.5–.4	0	0		0.5 kHz buzzer (BZOUT) signal output
	0	1		1 kHz buzzer (BZOUT) signal output
	1	0		2 kHz buzzer (BZOUT) signal output
	1	1		4 kHz buzzer (BZOUT) signal output
WTCON.3–.2	0	0		Set watch timer interrupt to 0.5 s.
	0	1		Set watch timer interrupt to 0.25 s.
	1	0		Set watch timer interrupt to 0.125 s.
	1	1		Set watch timer interrupt to 1.955 ms.
WTCON.1	0	Disable watch timer, clear frequency dividing circuits		
	1	Enable watch timer		
WTCON.0	0	Interrupt is not pending, clear pending bit when write		
	1	Interrupt is pending		

NOTE: Main system clock frequency (fx) is assumed to be 9.8304 MHz

WATCH TIMER CIRCUIT DIAGRAM

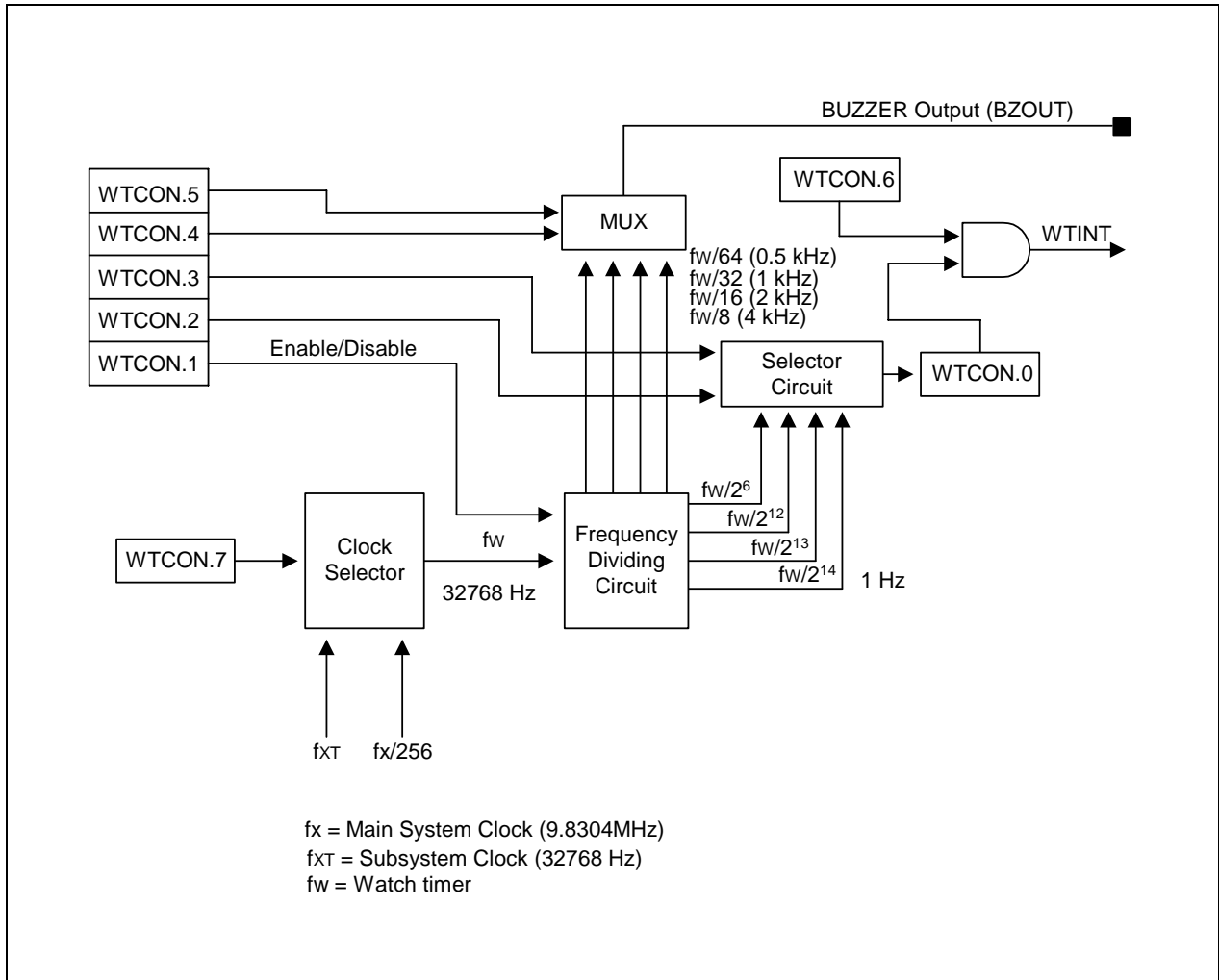


Figure 17-1. Watch Timer Circuit Diagram

 **PROGRAMMING TIP — Using the Watch Timer**

```

    ORG      0000h

    VECTOR  0D6h,WT_INT

    ORG      0100h

INITIAL:
    DI
    SB1                      ; Extra command only for debugging (note)
    LD      0F7H,#5FH        ; Extra command only for debugging (note)
    SB0                      ; Extra command only for debugging (note)

    LD      IMR,#00010000b   ; Enable IRQ3 interrupt
    LD      SPH,#00000000b   ; Set stack area
    LD      SPL,#0FFh
    LD      BTCON,#10100011b ; Disable Watch-dog
    LD      WTCON,#11001110b ; 0.5 kHz buzzer, 1.955ms duration interrupt
                                ; Interrupt enable, (fxt:32,768Hz)
    EI

MAIN:
    .
    .
    .
    MAIN ROUTINE
    .
    .
    .

    JR      T,MIAN

WT_INT:
    .
    .
    .
    AND     WTCON,#11111110b ; pending clear

    IRET

    .END

```

NOTE: In debug mode, you have to include three extra commands in initial routine to operate Ports correctly. If you omit these commands, Port do not operate correctly. After you have finished your program and before assembling, you have to remove these three commands.

18

LOW VOLTAGE RESET

OVERVIEW

The S3C84H5/F84H5 can be reset in four ways:

- by external power-on-reset
- by the external reset input pin pulled low
- by the digital watchdog timing out
- by the Low Voltage reset circuit (LVR)

During an external power-on reset, the voltage VDD is High level and the nRESET pin is forced Low level. The nRESET signal is input through a Schmitt trigger circuit where it is then synchronized with the CPU clock. This brings the S3C84H5/F84H5 into a known operating status. To ensure correct start-up, the user should take that reset signal is not released before the VDD level is sufficient to allow MCU operation at the chosen frequency.

The nRESET pin must be held to Low level for a minimum time interval after the power supply comes within tolerance in order to allow time for internal CPU clock oscillation to stabilize. The minimum required oscillation stabilization time for a reset is approximately 6.55 ms ($\approx 2^{16}/f_{osc}$, $f_{osc} = 10\text{MHz}$).

When a reset occurs during normal operation (with both VDD and nRESET at High level), the signal at the nRESET pin is forced Low and the reset operation starts. All system and peripheral control registers are then set to their default hardware reset values (see Table 8-1).

The MCU provides a watchdog timer function in order to ensure graceful recovery from software malfunction. If watchdog timer is not refreshed before an end-of-counter condition (overflow) is reached, the internal reset will be activated.

The S3C84H5/F84H5 has a built-in low voltage reset circuit that allows detection of power voltage drop of external V_{DD} input level to prevent a MCU from malfunctioning in an unstable MCU power level. This voltage detector works for the reset operation of MCU. This Low Voltage reset includes an analog comparator and Vref circuit. The value of a detection voltage is 2.8V. The on-chip Low Voltage Reset, features static reset when supply voltage is below a reference voltage value (Typical 2.8 V). Thanks to this feature, external reset circuit can be removed while keeping the application safety. As long as the supply voltage is below the reference value, there is an internal and static RESET. The MCU can start only when the supply voltage rises over the reference voltage.

When you calculate power consumption, please remember that a static current of LVR circuit should be added a CPU operating current in any operating modes such as Stop, Idle, and normal RUN mode.

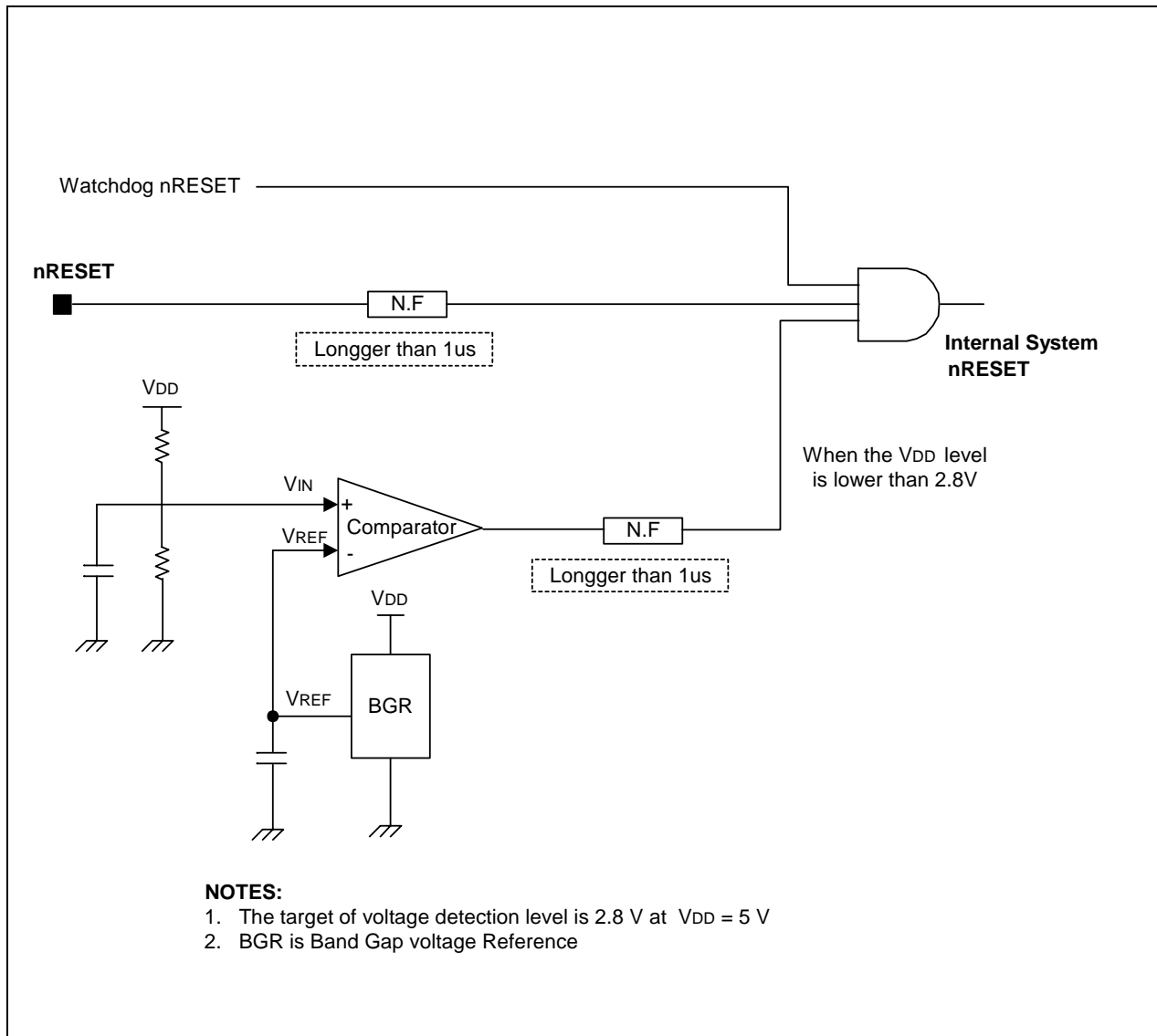


Figure 18-1. Low Voltage Reset Circuit

NOTE

To program the duration of the oscillation stabilization interval, you make the appropriate settings to the basic timer control register, BTCON, *before* entering Stop mode. Also, if you do not want to use the basic timer watchdog function (which causes a system reset if a basic timer counter overflow occurs), you can disable it by writing '1010B' to the upper nibble of BTCON.

19

MTP

OVERVIEW

The S3F84H5 single-chip CMOS microcontroller is the MTP (Multi Time Programmable) version of the S3C84H5 microcontroller. It has an on-chip Half Flash ROM instead of masked ROM. The Half Flash ROM is accessed by serial data format. The Half Flash ROM can be rewritten up to 100 times.

The S3F84H5 is fully compatible with the S3C84H5, in function, in D.C. electrical characteristics, and in pin configuration. Because of its simple programming requirements, the S3F84H5 is ideal for use as an evaluation chip for the S3C84H5.

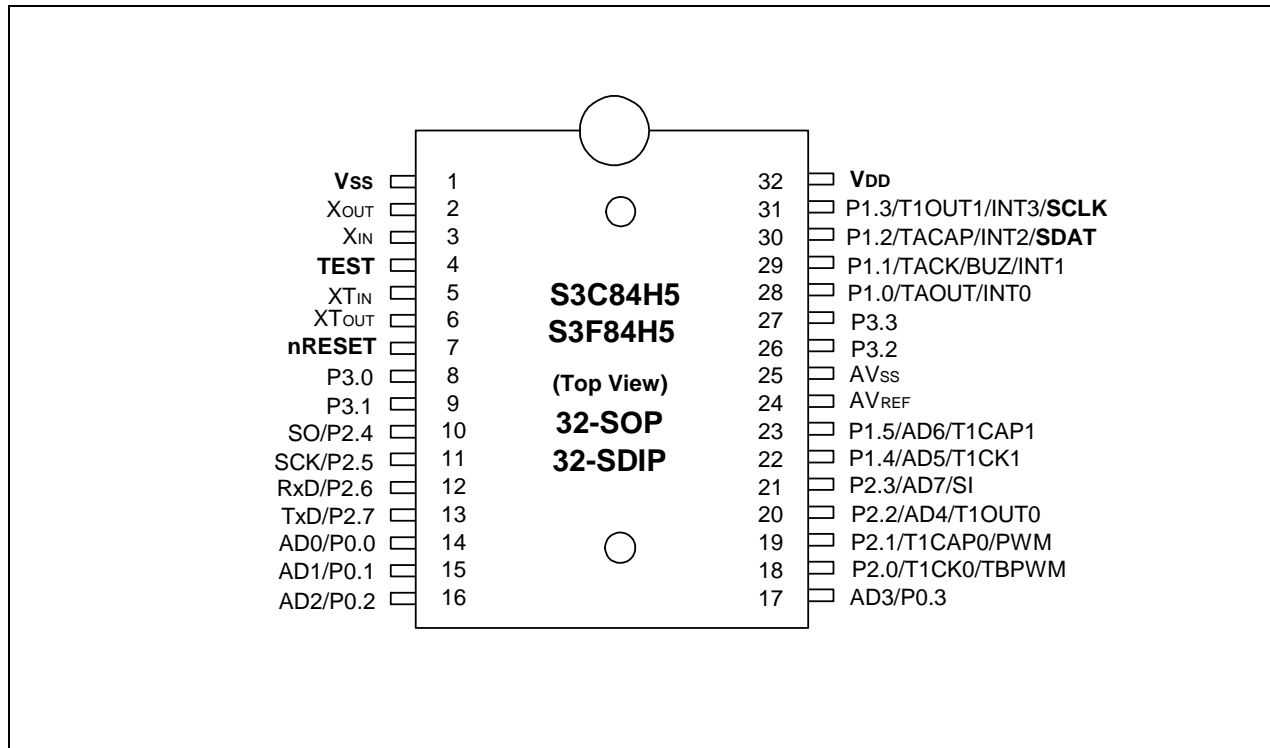


Figure 19-1. Pin Assignment (32-pin SOP/SDIP)

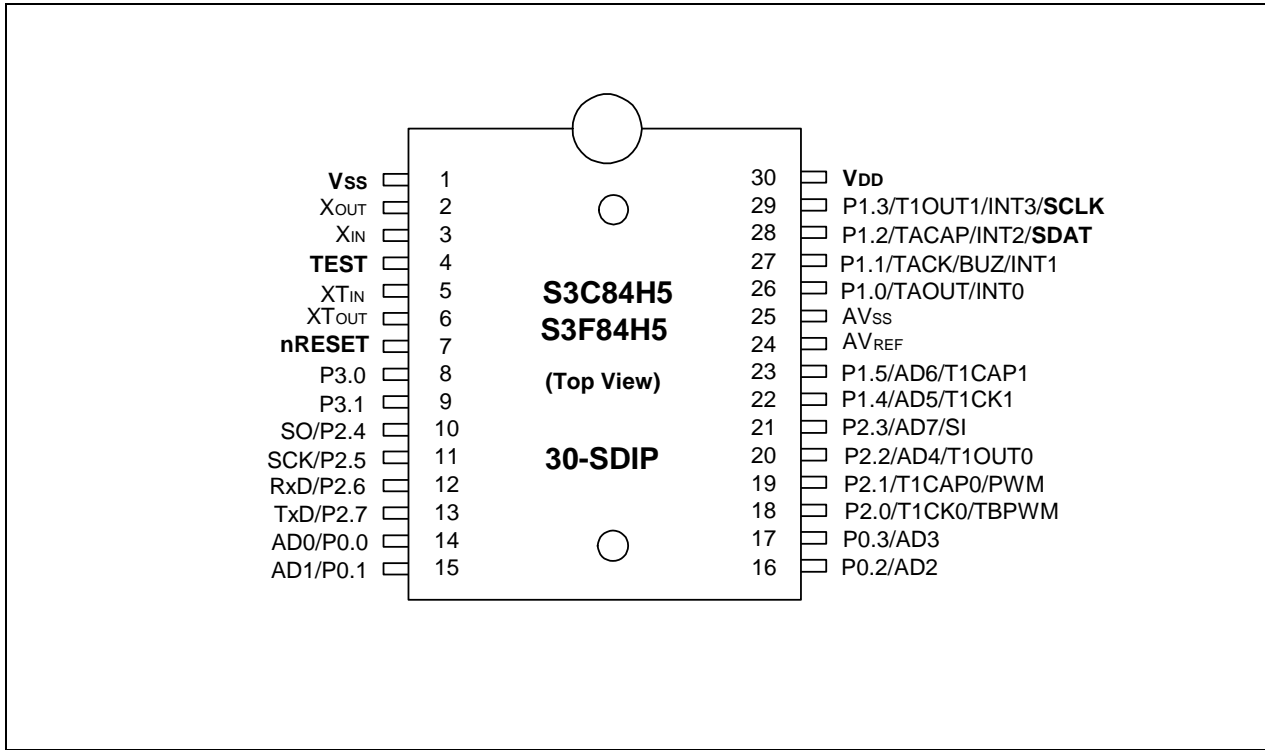


Figure 19-2. Pin Assignment (30-pin SDIP)

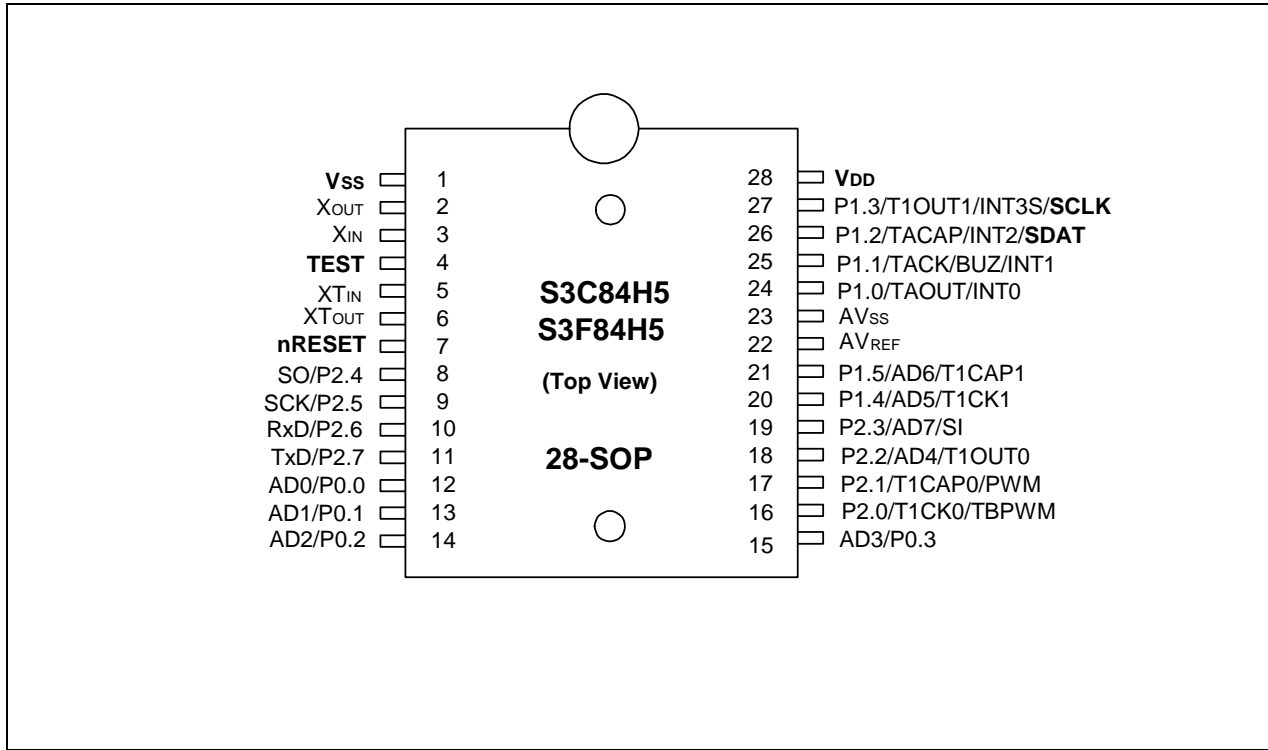


Figure 19-3. Pin Assignment (28-pin SOP)

Table 19-1. Descriptions of Pins Used to Read/Write the Flash ROM

Main Chip Pin Name	During Programming			
	Pin Name	Pin No.	I/O	Function
P1.2	SDAT	30 (32-pin) 28 (30-pin) 26 (28-pin)	I/O	Serial data pin (output when reading, Input when writing) Input and push-pull output port can be assigned
P1.3	SCLK	31 (32-pin) 29 (30-pin) 27 (28-pin)	I	Serial clock pin (input only pin)
TEST	VPP	4	I	Power supply pin for flash ROM cell writing (indicates that MTP enters into the writing mode). When 12.5 V is applied, MTP is in writing mode and when 5 V is applied, MTP is in reading mode. (Option)
nRESET	nRESET	7	I	
VDD/VSS	V _{DD} /V _{SS}	32/1 (32-pin) 30/1 (30-pin) 28/1 (28-pin)	I	Logic power supply pin.

Table 19-2. Comparison of S3F84H5 and S3C84H5 Features

Characteristic	S3F84H5	S3C84H5
Program Memory	16 Kbyte Flash ROM	16K byte mask ROM
Operating Voltage (V _{DD})	2.8 V to 5.5 V	2.8 V to 5.5 V
MTP Programming Mode	V _{DD} = 5 V, V _{PP} = 12.5 V	
Pin Configuration	32 SDIP/ SOP, 30 SDIP, 28 SOP	
EPROM Programmability	User Program multi time	Programmed at the factory

20

ELECTRICAL DATA

OVERVIEW

In this chapter, S3C84H5/F84H5 electrical characteristics are presented in tables and graphs. The information is arranged in the following order:

- Absolute maximum ratings
- Input/output capacitance
- D.C. electrical characteristics
- A.C. electrical characteristics
- Oscillation characteristics
- Oscillation stabilization time
- Data retention supply voltage in stop mode
- UART timing characteristics in mode 0
- A/D converter electrical characteristics

Table 20-1. Absolute Maximum Ratings

(T_A = 25°C)

Parameter	Symbol	Conditions	Rating	Unit
Supply Voltage	V _{DD}	–	– 0.3 to + 6.5	V
Input Voltage	V _I	All input ports	– 0.3 to V _{DD} + 0.3	
Output Voltage	V _O	All output ports	– 0.3 to V _{DD} + 0.3	
Output Current High	I _{OH}	One I/O pin active	– 18	mA
		All I/O pins active	– 60	
Output Current Low	I _{OL}	One I/O pin active	+ 30	
		All I/O pins active	+ 200	
Operating Temperature	T _A	–	– 25 to + 85	°C
Storage Temperature	T _{STG}	–	– 65 to + 150	

Table 20-2. Input/Output Capacitance

(T_A = – 25°C to 85°C, V_{DD} = 0 V)

Parameter	Symbol	Conditions	Min	Typ.	Max	Unit
Input Capacitance	C _{IN}	f = 1 MHz; unmeasured pins are tied to V _{SS}	–	–	10	pF
Output Capacitance	C _{OUT}					
I/O Capacitance	C _{IO}					

Table 20-3. D.C. Electrical Characteristics

(T_A = -25°C to +85°C, 2.5V to 5.5 V)

Parameter	Symbol	Conditions	Min	Typ.	Max	Unit
Operating Voltage	V _{DD}	fx = 0 – 8MHz, fxt = 32.8kHz LVR off	2.5		5.5	V
		fx = 0 – 8MHz, fxt = 32.8kHz LVR on	LVR		5.5	
		fx = 0 – 10MHz	4.5		5.5	
Input High Voltage	V _{IH1}	V _{DD} = 2.5V to 5.5 V All Port and nRESET	0.8 V _{DD}	–	V _{DD}	V
	V _{IH2}	V _{DD} = 2.5V to 5.5 V X _{IN} and XT _{IN}	V _{DD} – 0.5			
Input Low Voltage	V _{IL1}	V _{DD} = 2.5V to 5.5 V All Ports and nRESET	–	–	0.2V _{DD}	V
	V _{IL2}	V _{DD} = 2.5V to 5.5 V X _{IN} and XT _{IN}			0.4	
Output High Voltage	V _{OH}	V _{DD} = 5.0 V I _{OH} = – 2 mA All Ports	V _{DD} – 1.0	–	–	V
Output Low Voltage	V _{OL1}	V _{DD} = 5.0 V, I _{OL} = 16 mA Ports 0 and 4	–	0.4	2.0	V
	V _{OL2}	V _{DD} = 5.0 V, I _{OL} = 4 mA Ports 1, 2 and 3				
Input High Leakage Current	I _{LIH1}	V _{IN} = V _{DD} All input pins except I _{LIH2}	–	–	3	μA
	I _{LIH2}	V _{IN} = V _{DD} X _{IN} , X _{OUT} and XT _{IN} , XT _{OUT}			20	
Input Low Leakage Current	I _{LIL1}	V _{IN} = 0 V All input pins except and I _{LIL2}	–	–	– 3	
	I _{LIL2}	V _{IN} = 0 V X _{IN} , X _{OUT} and XT _{IN} , XT _{OUT}			– 20	
Output High Leakage Current	I _{LOH}	V _{OUT} = V _{DD} All output pins	–	–	3	
Output Low Leakage Current	I _{LOL}	V _{OUT} = 0 V All output pins	–	–	–3	

Table 20-3. D.C. Electrical Characteristics (Concluded)

(T_A = -25°C to +85°C, V_{DD} = 2.5 V to 5.5 V)

Parameter	Symbol	Conditions	Min	Typ.	Max	Unit
Pull-up Resistor	R _{P1}	V _{DD} = 5 V; V _{IN} = 0 V T _A = 25 °C All I/O pins except nRESET	25	50	100	kΩ
	R _{P2}	V _{DD} = 5 V; V _{IN} = 0 V T _A = 25 °C RESETB only	150	250	480	
Supply Current ⁽¹⁾	I _{DD1(2)}	V _{DD} = 4.5 V to 5.5 V RUN mode 10 MHz CPU clock	-	5.0	10	mA
		V _{DD} = 2.5 V to 3.3 V RUN mode 4 MHz CPU clock		2.5	5.0	
	I _{DD2}	V _{DD} = 4.5 V to 5.5 V Idle mode 10 MHz CPU clock	-	2.0	4.0	
		V _{DD} = 2.5 V to 3.3 V Idle mode 4 MHz CPU clock		1.0	2.0	
	I _{DD3}	Sub operating: main-osc stop V _{DD} = 2.5 V to 3.3 V 32768 Hz crystal oscillator	-	400	800	uA
	I _{DD4}	Sub idle mode: main-osc stop V _{DD} = 2.5 V to 3.3 V 32768 Hz crystal oscillator	-	300	600	
	I _{DD5(3)}	V _{DD} = 4.5V to 5.5 V, T _A =25°C, Stop mode	-	150	400	

NOTES:

- Supply current does not include current drawn through internal pull-up resistors or external output current loads.
- IDD1 and IDD2 include a power consumption of subsystem oscillator.
- IDD3 and IDD4 are the current when the main system clock oscillation stop and the subsystem clock is used.
- IDD5 is the current when the main and subsystem clock oscillation stop.
- All currents (IDD1- IDD5) include the current consumption of LVR circuit.(Except the case that LVR is disabled)
- IDD5 is the same regardless of LVR on or LVR off.

Table 20-4. A.C. Electrical Characteristics

(T_A = -25°C to +85°C, 2.5V to 5.5 V)

Parameter	Symbol	Conditions	Min	Typ.	Max	Unit
Interrupt Input High, Low Width (Ports 2)	t _{INTH} , t _{INTL}	V _{DD} = 5 V	180	–	–	ns
RESETB Input Low Width	t _{RSL}	Input	1.0	–	–	μs

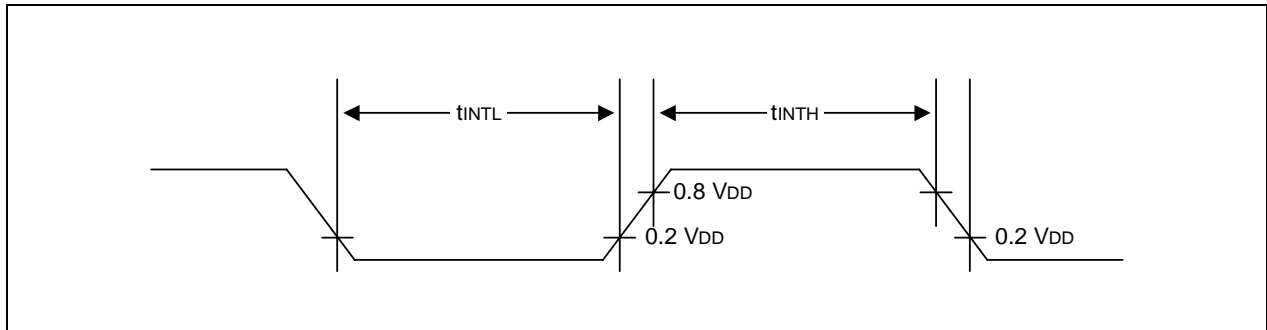
NOTE: User must keep more large value then min value.

Figure 20-1. Input Timing for External Interrupts (Ports 2)

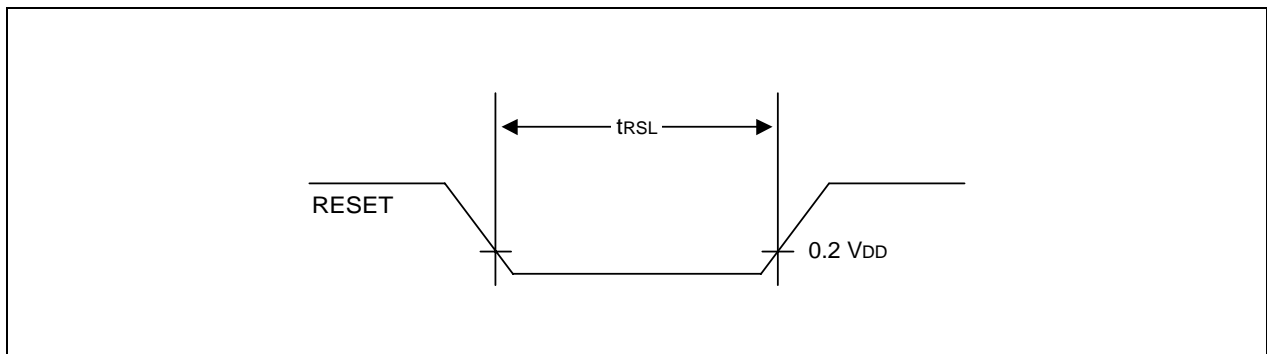


Figure 20-2. Input Timing for RESET

Table 20-5. Main Oscillator Frequency (f_{OSC1}) $(T_A = -25^\circ\text{C} + 85^\circ\text{C}, 2.5\text{V to } 5.5\text{V})$

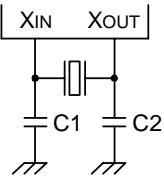
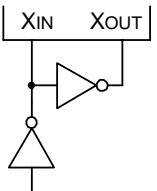
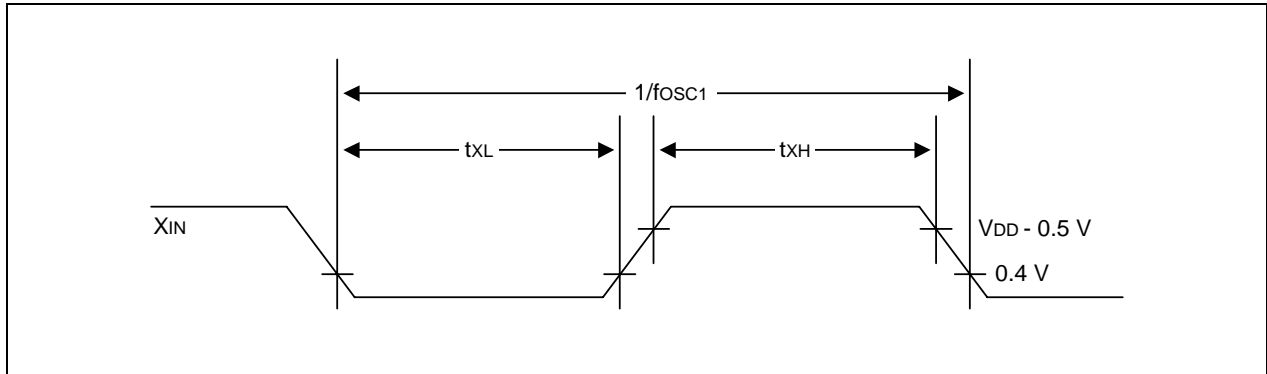
Oscillator	Clock Circuit	Test Condition	Min	Typ.	Max	Unit
Main Crystal or Ceramic		$V_{DD} = 2.5\text{V to } 5.5\text{V}$	1	–	10	MHz
External Clock (Main System)		$V_{DD} = 2.5\text{V to } 5.5\text{V}$	1	–	10	MHz

Table 20-6. Main Oscillator Clock Stabilization Time (t_{ST1}) $(T_A = -25^\circ\text{C} + 85^\circ\text{C}, 2.5\text{V to } 5.5\text{V})$

Oscillator	Test Condition	Min	Typ.	Max	Unit
Main Crystal	$f_{OSC} > 400\text{ kHz}$;	–	–	10	ms
Main Ceramic	Oscillation stabilization occurs when V_{DD} is equal to the minimum oscillator voltage range.	–	–	4	
External Clock (Main System)	X_{IN} input High and Low width (t_{XH} , t_{XL})	50	–	–	ns
Oscillator Stabilization Wait Time	t_{WAIT} when released by a reset ⁽¹⁾	–	$2^{16}/f_{OSC}$	–	sec
	t_{WAIT} when released by an interrupt ⁽²⁾	–	–	–	sec

NOTES:

- f_{OSC} is the oscillator frequency.
- The duration of the oscillator stabilization wait time, t_{WAIT} , when it is released by an interrupt is determined by the settings in the basic timer control register, BTCON.

Figure 20-3. Clock Timing Measurement at X_{IN} Table 20-7. Sub Oscillator Frequency (f_{OSC2})

($T_A = -25\text{ }^\circ\text{C} + 85\text{ }^\circ\text{C}$, $V_{DD} = 2.5$ to 5.5 V)

Oscillator	Clock Circuit	Test Condition	Min	Typ.	Max	Unit
Crystal		Crystal oscillation frequency $C1 = 100\text{ pF}$, $C2 = 100\text{ pF}$ $R = 330\text{ }\Omega$ X_{TIN} and X_{TOUT} are connected with R and C by soldering.	32	32.768	34	kHz

Table 20-8. Subsystem Oscillator (crystal) Stabilization Time (t_{ST2})

($T_A = 25\text{ }^\circ\text{C}$)

Test Condition	Min	Typ.	Max	Unit
$V_{DD} = 4.5$ V to 5.5 V	–	800	1600	ms
$V_{DD} = 2.5$ to 3.3 V	–		10	s

NOTE: Oscillation stabilization time (t_{ST2}) is the time required for the oscillator to its normal oscillation when stop mode is released by interrupts.

Table 20-9. Data Retention Supply Voltage in Stop Mode

(T_A = -25°C to +85°C, 2.5V to 5.5 V)

Parameter	Symbol	Conditions	Min	Typ	Max	Unit
Data Retention Supply Voltage	V _{DDDR}	Stop mode	2.5	–	5.5	V
Data Retention Supply Current	I _{DDDR}	Stop mode, V _{DDDR} = 2.7 V	–	–	8	μA

NOTE: Supply current does not include current drawn through internal pull-up resistors or external output current loads.

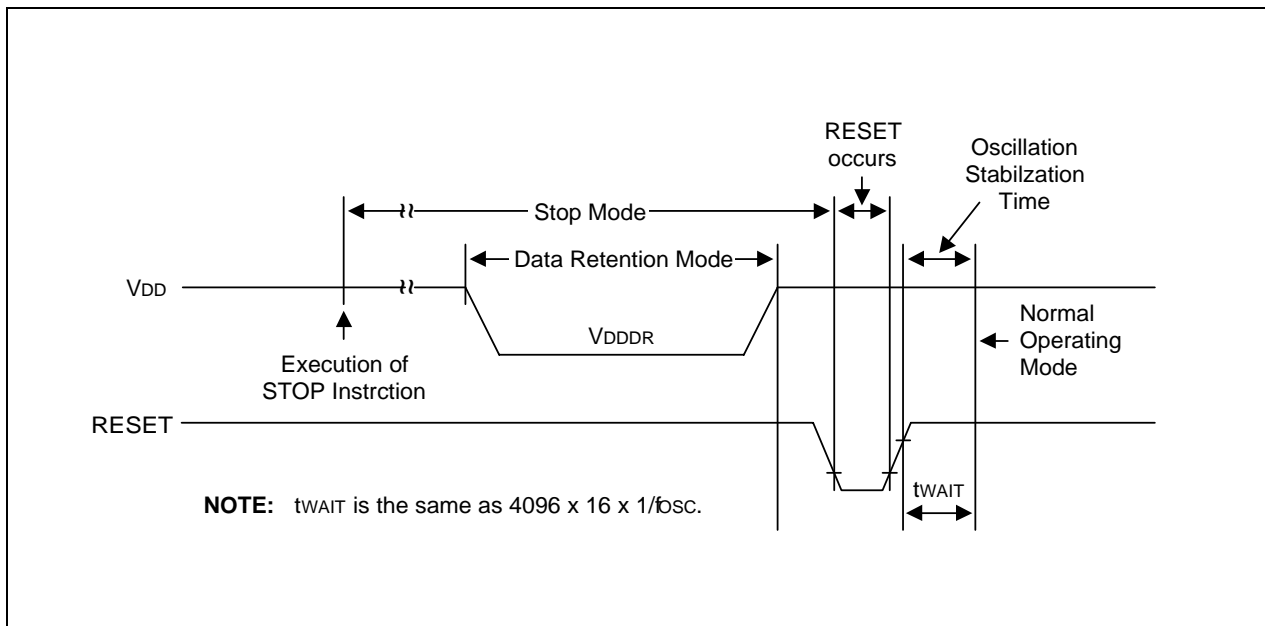


Figure 20-4. Stop Mode Release Timing initiated by RESET

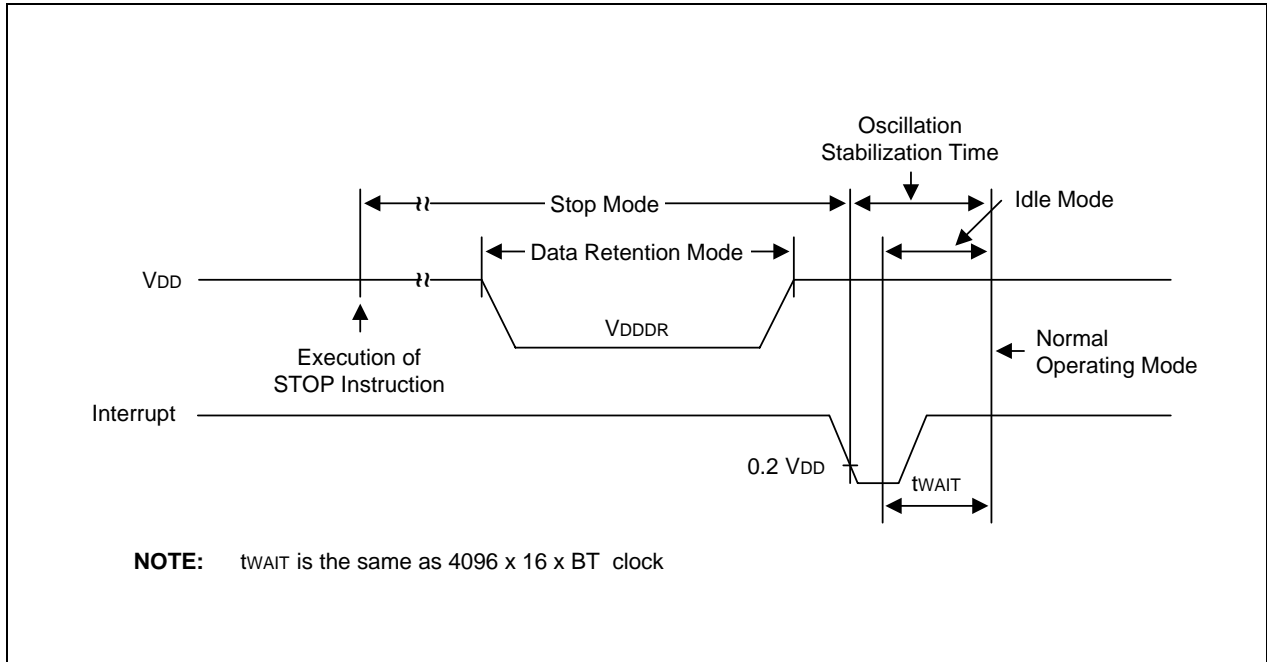


Figure 20-5. Stop Mode (Main) Release Timing Initiated by Interrupts

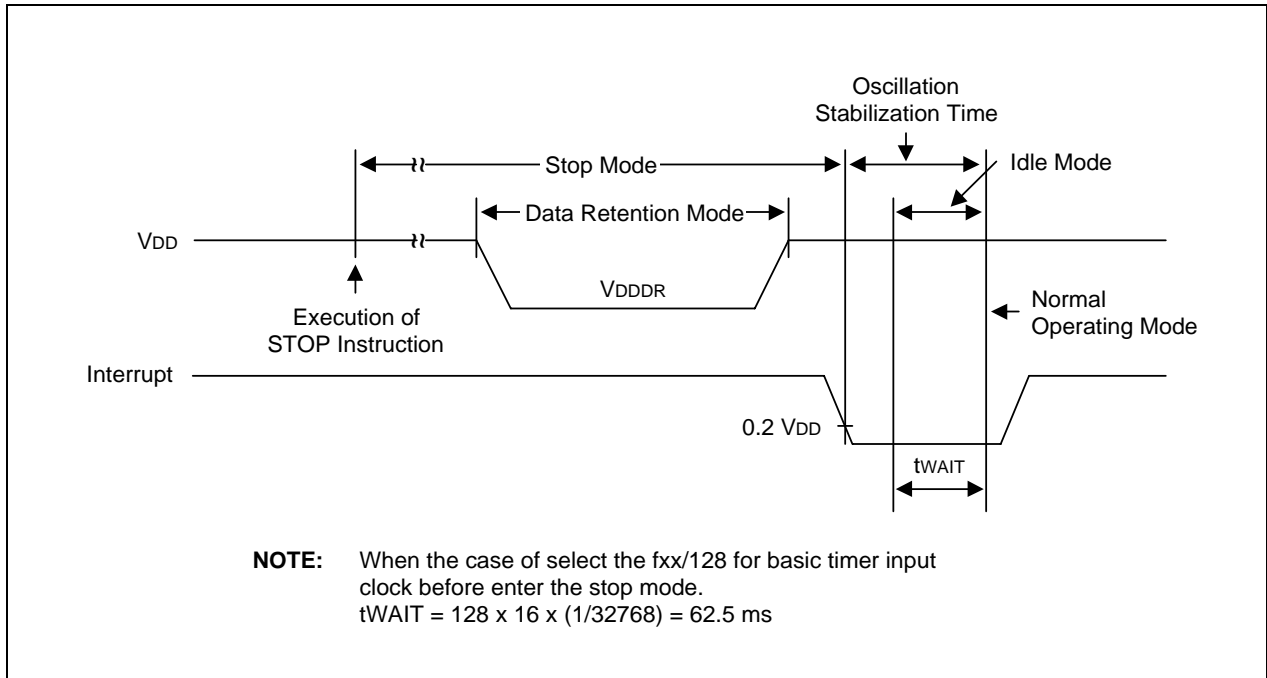


Figure 20-6. Stop Mode (Sub) Release Timing Initiated by Interrupts

Table 20-10. UART Timing Characteristics in Mode 0 (10 MHz)

(T_A = -25°C to +85°C, 2.5V to 5.5 V, Load capacitance = 80 pF)

Parameter	Symbol	Min	Typ.	Max	Unit
Serial port clock cycle time	t _{SCK}	500	t _{CPU} × 6	700	ns
Output data setup to clock rising edge	t _{S1}	300	t _{CPU} × 5	–	
Clock rising edge to input data valid	t _{S2}	–	–	300	
Output data hold after clock rising edge	t _{H1}	t _{CPU} – 50	t _{CPU}	–	
Input data hold after clock rising edge	t _{H2}	0	–	–	
Serial port clock High, Low level width	t _{HIGH} , t _{LOW}	200	t _{CPU} × 3	400	

NOTES:

- All timings are in nanoseconds (ns) and assume a 10-MHz CPU clock frequency.
- The unit t_{CPU} means one CPU clock period.

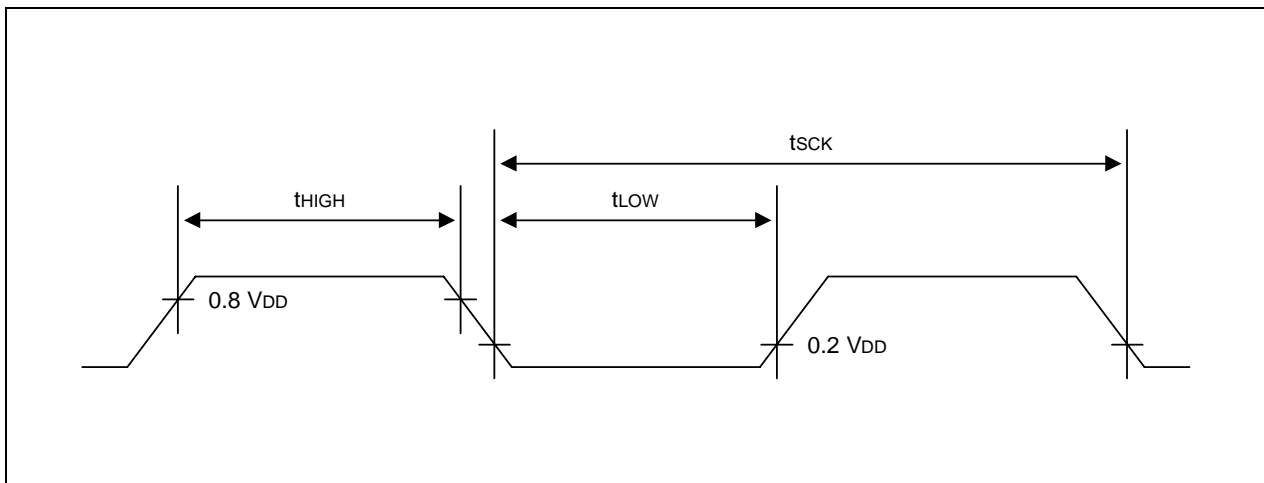


Figure 20-7. Waveform for UART Timing Characteristics

Table 20-11. A/D Converter Electrical Characteristics

(T_A = -25°C to +85°C, 2.5V to 5.5 V, V_{SS} = 0 V)

Parameter	Symbol	Test Conditions	Min	Typ.	Max	Unit
Resolution			-	10	-	bit
Total accuracy		V _{DD} = 5.12 V	-	-	± 3	LSB
Integral linearity error	ILE	CPU clock = 10 MHz AV _{REF} = 5.12 V		-	± 2	
Differential linearity error	DLE	AV _{SS} = 0 V		-	± 1	
Offset error of top	EOT			± 1	± 3	
Offset error of bottom	EOB			± 0.5	± 2	
Conversion time (1)	t _{CON}	10-bit conversion 50 × 4/f _{OSC} (3), f _{OSC} = 10 MHz	20	-	-	μs
Analog input voltage	V _{IAN}	-	AV _{SS}	-	AV _{REF}	V
Analog input impedance	R _{AN}	-	2	1000	-	MΩ
Analog reference voltage	AV _{REF}	-	2.5	-	V _{DD}	V
Analog ground	AV _{SS}	-	V _{SS}	-	V _{SS} + 0.3	
Analog input current	I _{ADIN}	AV _{REF} = V _{DD} = 5 V conversion time = 20 μs	-	-	10	μA
Analog block current (2)	I _{ADC}	AV _{REF} = V _{DD} = 5 V conversion time = 20 μs		1	3	mA
		AV _{REF} = V _{DD} = 3 V conversion time = 20 μs		0.5	1.5	
		AV _{REF} = V _{DD} = 5 V when power down mode		100	500	nA

NOTES:

- "Conversion time" is the time required from the moment a conversion operation starts until it ends.
- I_{ADC} is operating current during A/D conversion.
- f_{OSC} is the main oscillator clock.

Table 20-12. LVR(Low Voltage Reset) Circuit Characteristics

(T_A = 25 °C)

Parameter	Symbol	Test Condition	Min	Typ	Max	Unit
LVR Voltage Level	V _{LVR}	LVR is enabled by smart option T _A = 25 °C	2.5	2.8	3.1	V

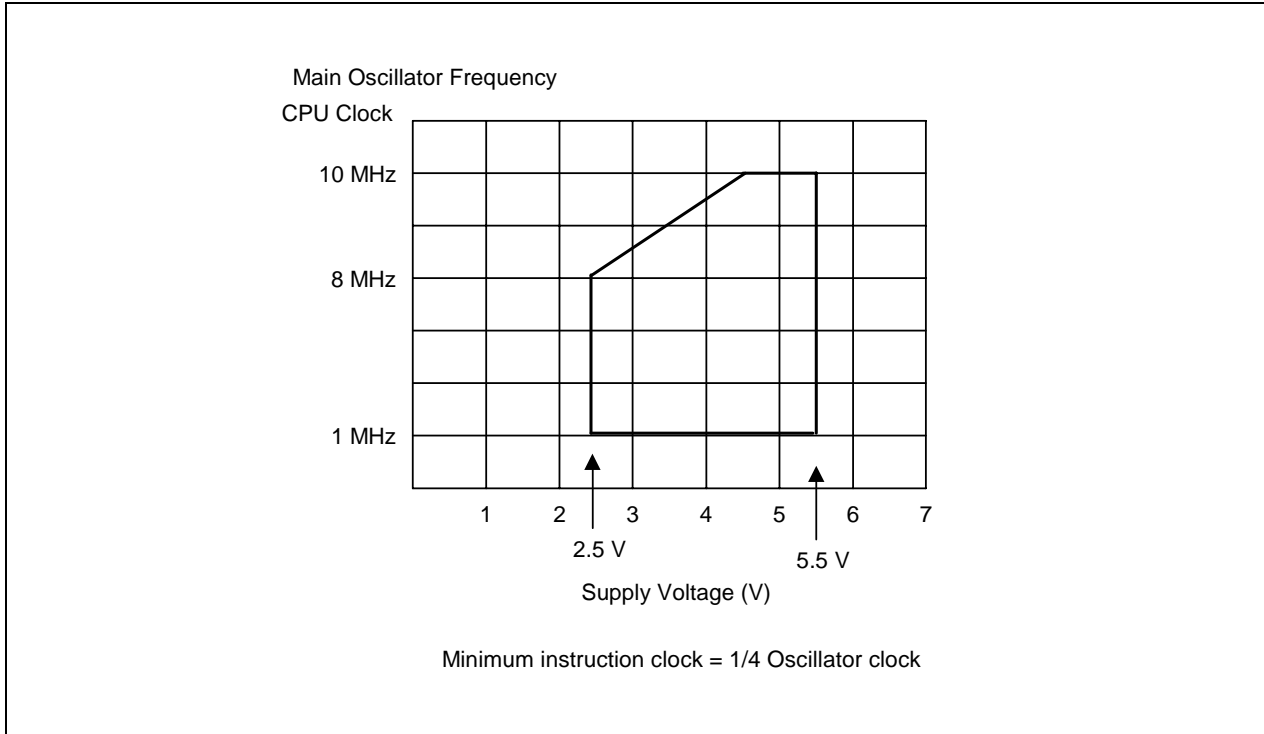


Figure 20-8. Operating Voltage Range

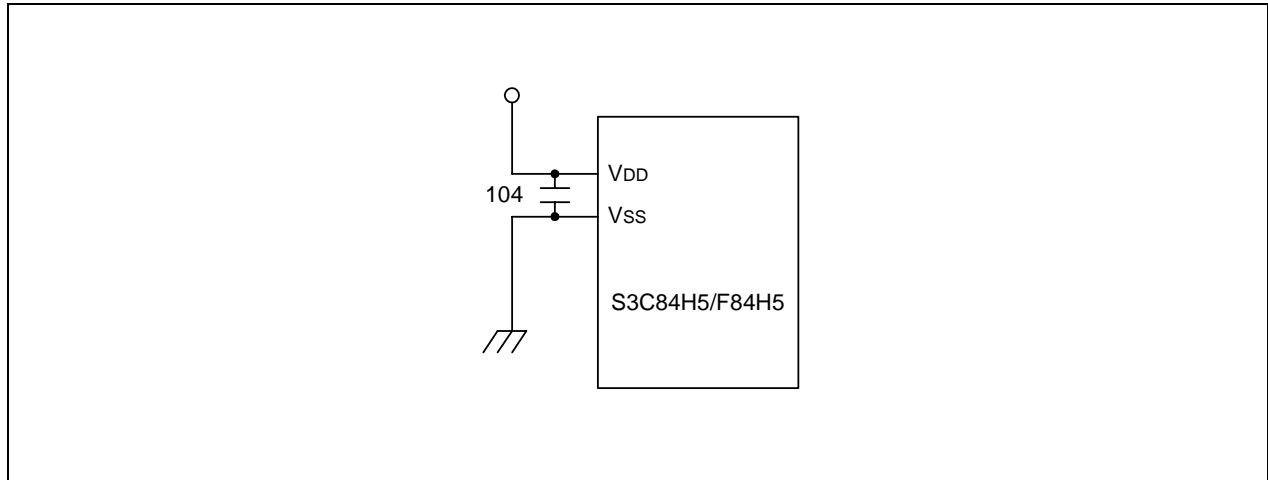


Figure 20-9. The Circuit Diagram to Improve EFT Characteristics

NOTE: To improve EFT characteristics, we recommend using power capacitor near S3C84H5/F84H5 like Figure 20-9.

21

MECHANICAL DATA

OVERVIEW

The S3F84H5 is available in a 30-pin SDIP package (Samsung: 30-SDIP-400) and a 32-pin SOP package (32-SOP-450A) and 32-pin SDIP package (Samsung: 32-SDIP-400) and a 28-pin SOP package (28-SOP-375). Package dimensions are shown in Figures 21-1, and 21-2

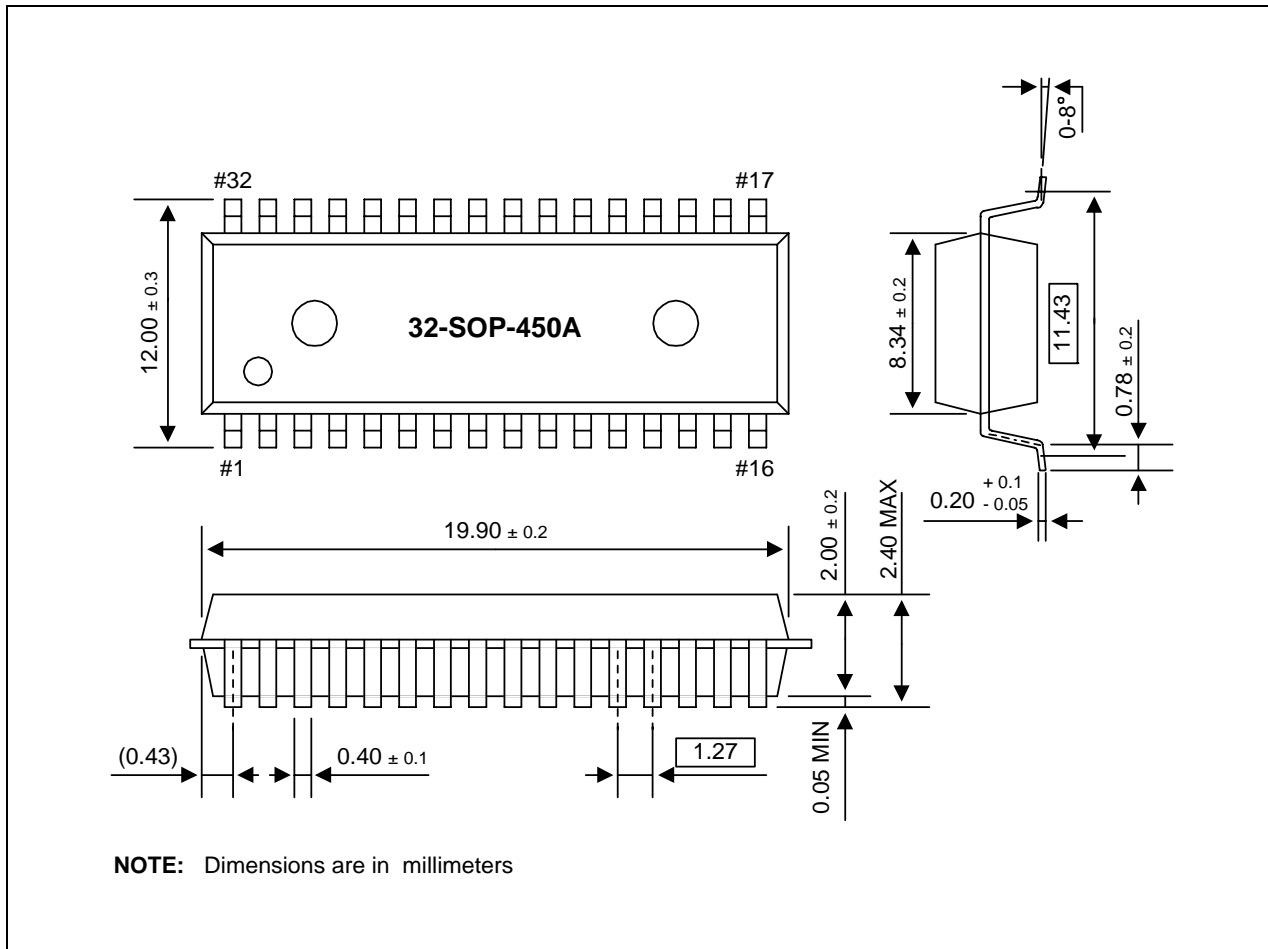


Figure 21-1. 32-SOP-450A Package Dimensions

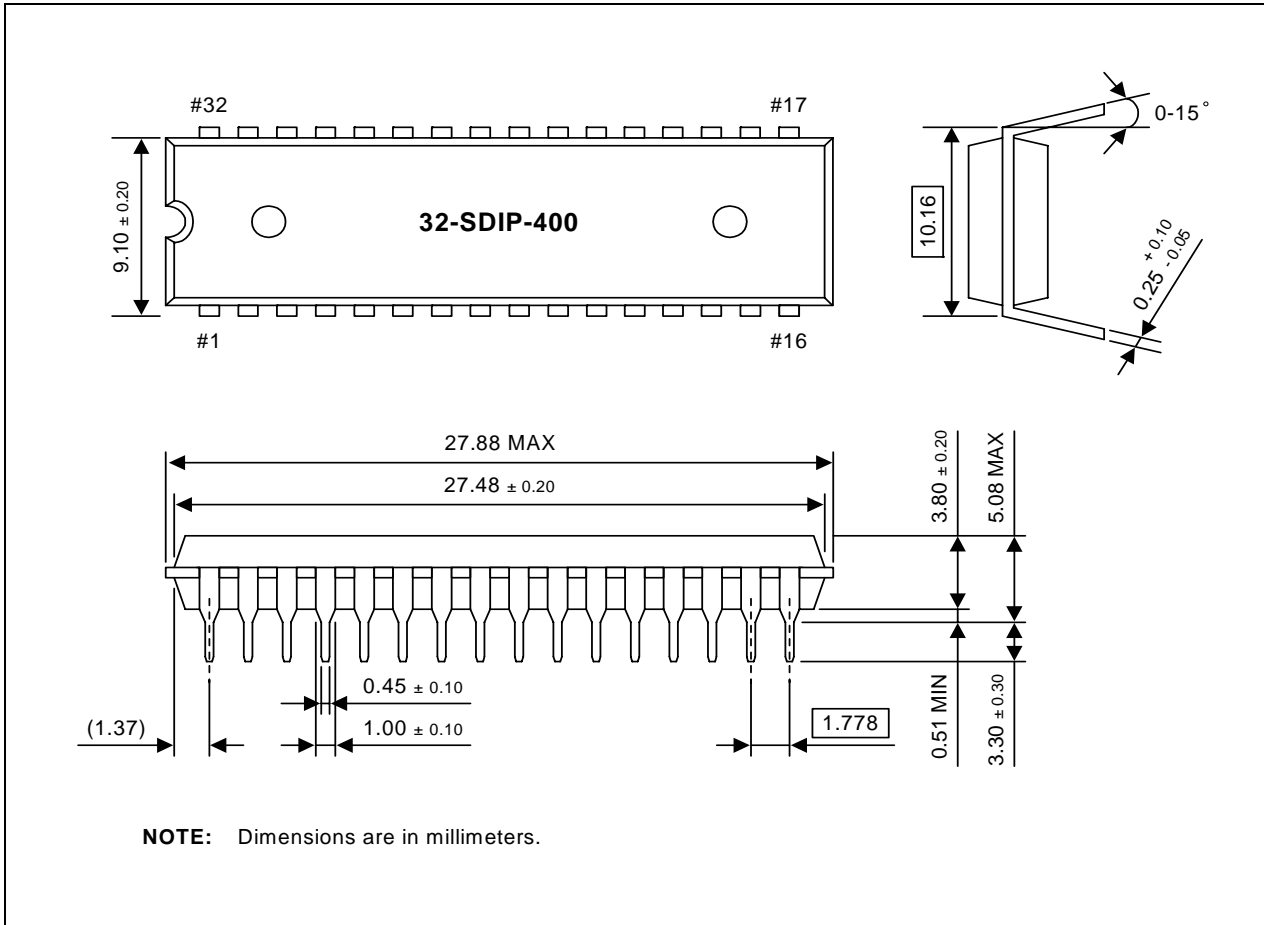


Figure 21-2. 32-SDIP-400 Package Dimensions

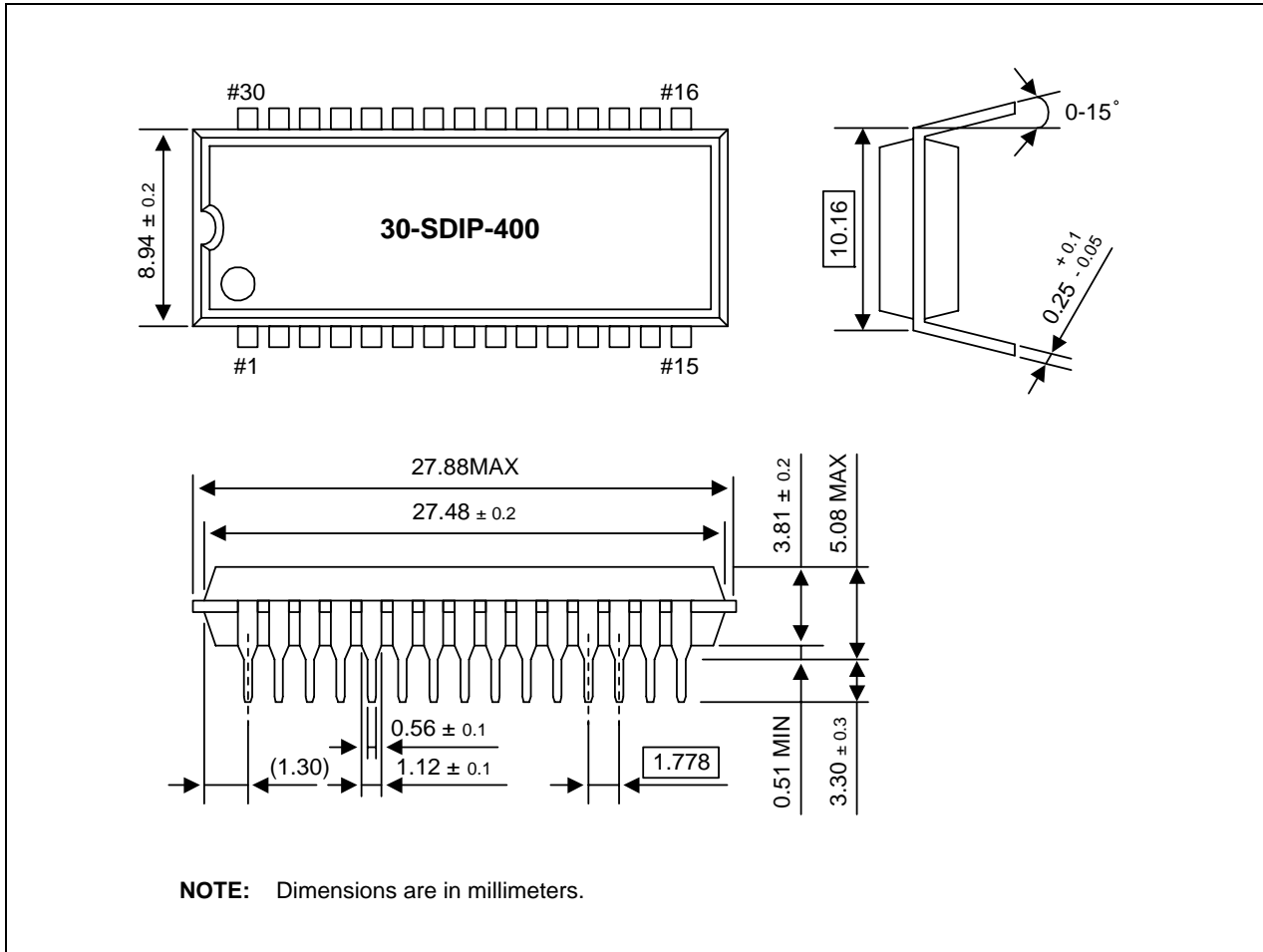


Figure 21-3. 30-Pin SDIP Package Dimensions

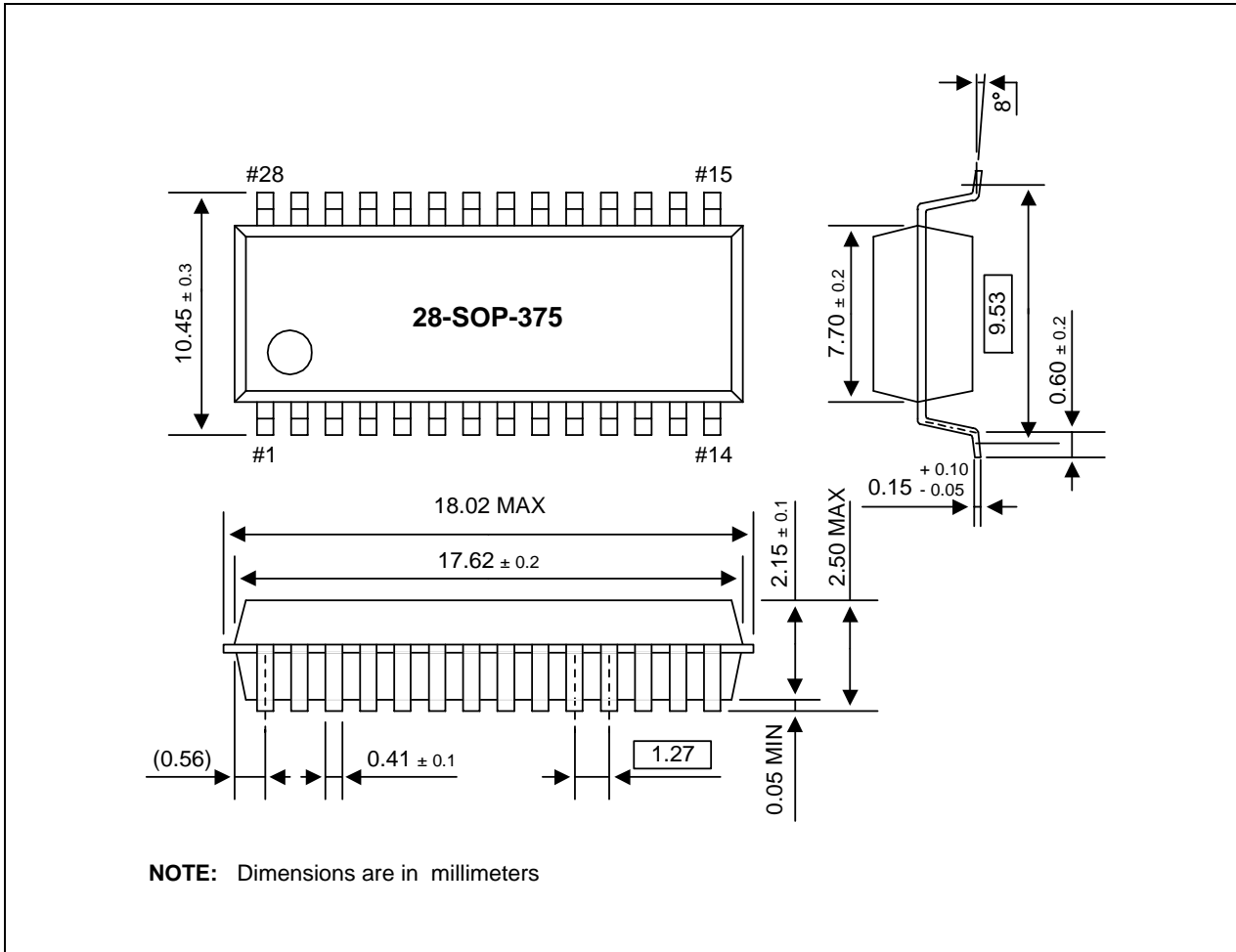


Figure 21-4. 28-SOP-375 Package Dimensions

22

DEVELOPMENT TOOLS

OVERVIEW

Samsung provides a powerful and easy-to-use development support system on a turnkey basis. The development support system is composed of a host system, debugging tools, and supporting software. For a host system, any standard computer that employs Win95/98/2000 as its operating system can be used. A sophisticated debugging tool is provided both in hardware and software: the powerful in-circuit emulator, SMDS2+ or SK-1000, for the S3C7-, S3C9-, and S3C8- microcontroller families. SMDS2+ is a newly improved version of SMDS2, and SK-1000 is supported by a third party tool vendor. Samsung also offers supporting software that includes, debugger, an assembler, and a program for setting options.

SHINE

Samsung Host Interface for In-Circuit Emulator, SHINE, is a multi-window based debugger for SMDS2+. SHINE provides pull-down and pop-up menus, mouse support, function/hot keys, and context-sensitive hyper-linked help. It has an advanced, multiple-windowed user interface that emphasizes ease of use. Each window can be easily sized, moved, scrolled, highlighted, added, or removed.

SASM

The SASM is a re-locatable assembler for Samsung's S3C8-series microcontrollers. The SASM takes a source file containing assembly language statements and translates them into a corresponding source code, an object code and comments. The SASM supports macros and conditional assembly. It runs on the MS-DOS operating system. As it produces the re-locatable object codes only, the user should link object files. Object files can be linked with other object files and loaded into memory. SASM requires a source file and an auxiliary register file (device_name.reg) with device specific information.

SAMA ASSEMBLER

The Samsung Arrangeable Microcontroller (SAM) Assembler, SAMA, is a universal assembler, and generating an object code in the standard hexadecimal format. Assembled program codes include the object code used for ROM data and required In-circuit emulators program control data. To assemble programs, SAMA requires a source file and an auxiliary definition (device_name.def) file with device specific information.

HEX2ROM

HEX2ROM file generates a ROM code from a HEX file which is produced by the assembler. A ROM code is needed to fabricate a microcontroller which has a mask ROM. When generating a ROM code (.OBJ file) by HEX2ROM, the value "FF" is automatically filled into the unused ROM area, up to the maximum ROM size of the target device.

TARGET BOARDS

Target boards are available for all the S3C8-series microcontrollers. All the required target system cables and adapters are included on the device-specific target board. TB84H5 is a specific target board for the S3C84H5/F84H5 development.

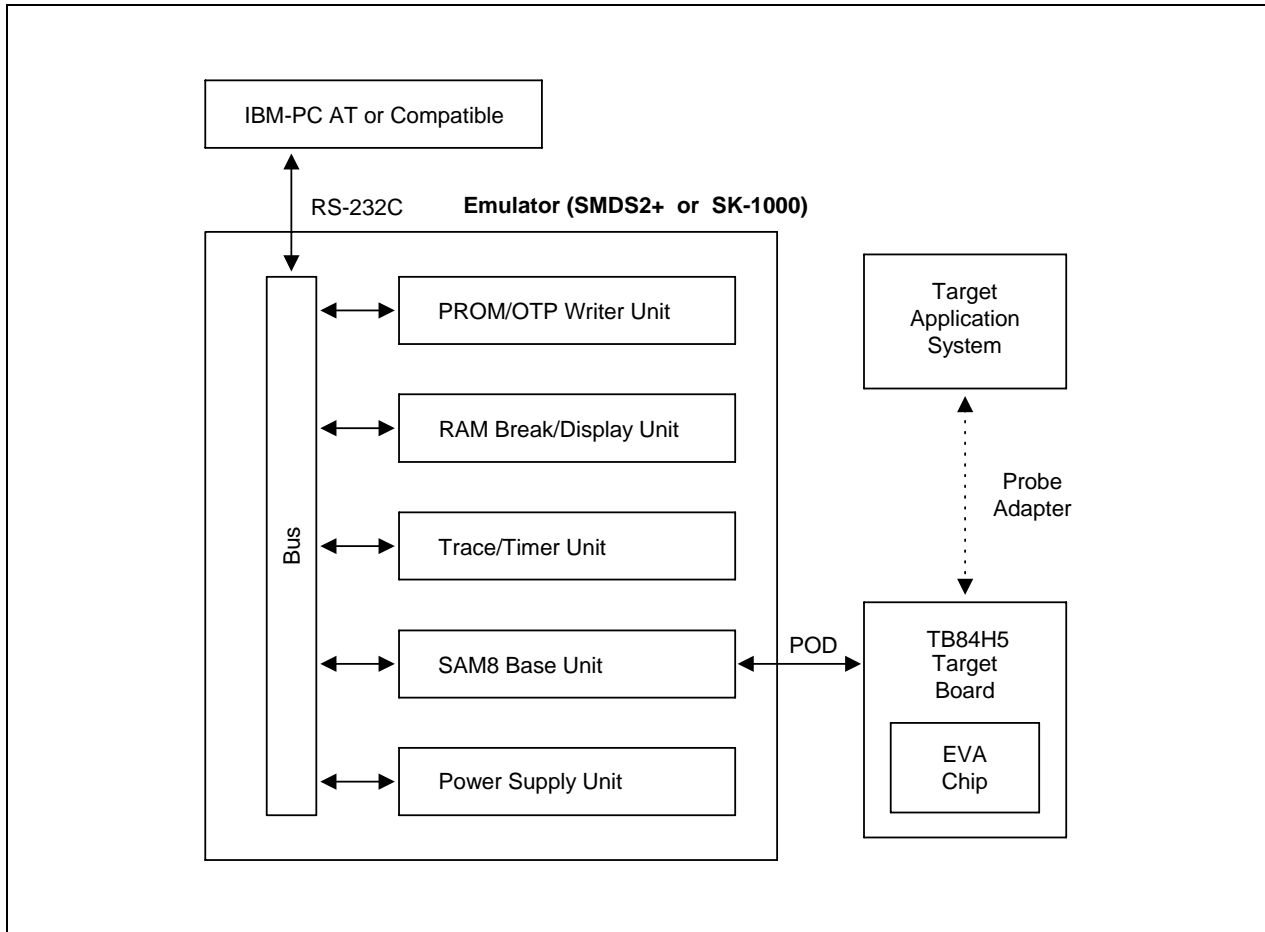


Figure 22-1. SMDS+ or SK-1000 Product Configuration

TB84H5 TARGET BOARD

The TB84H5 target board is used for the S3C84H5 and the S3F84H5 microcontroller. It is supported by the SMDS2+ or SK-1000 development system (In-Circuit Emulator). Figure 22-2. TB84H5 Target Board Configuration

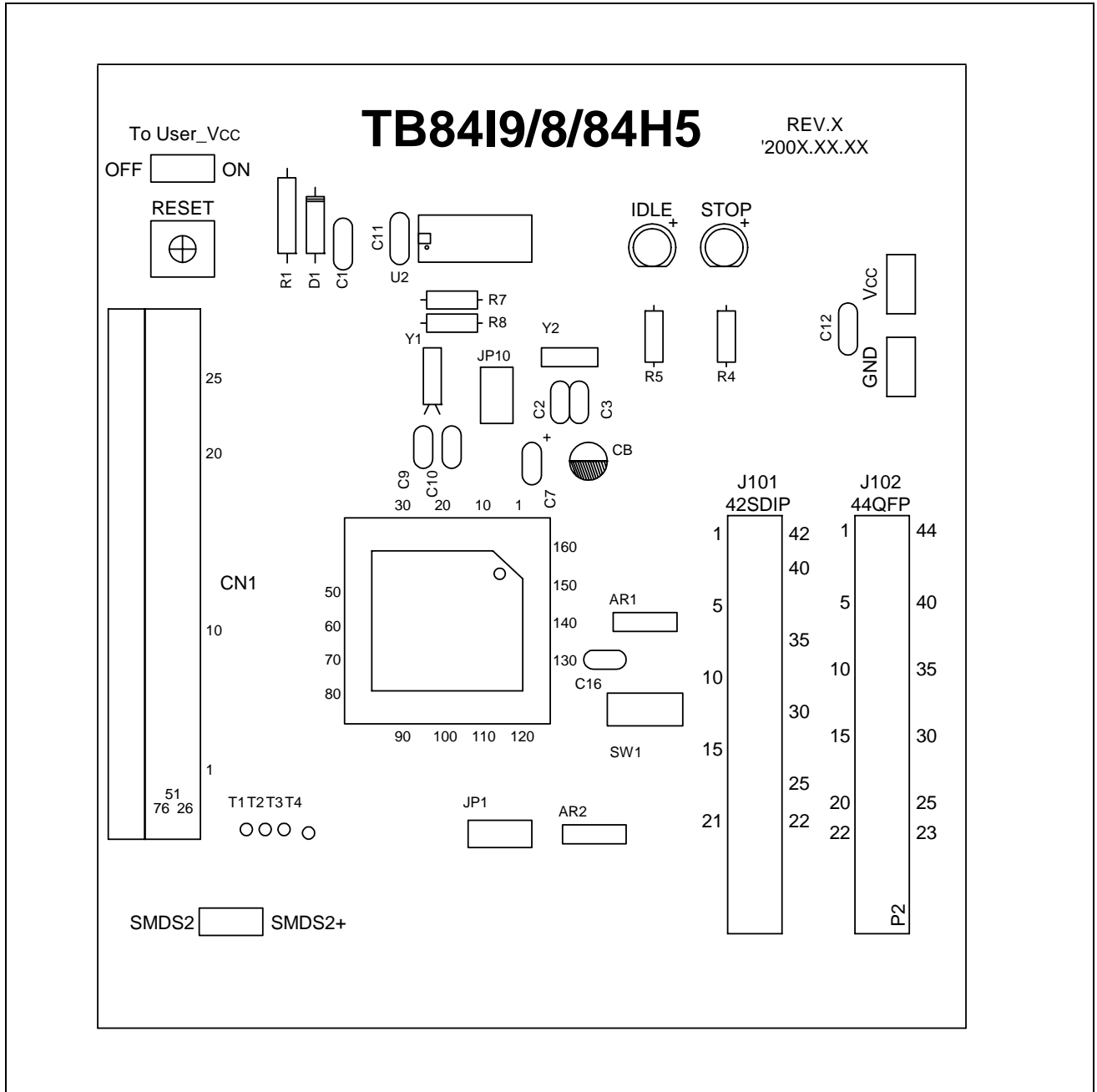


Figure 22-2. S3F84I9/ S3F84I8/S3F84H5 Target Board Configuration

Table 22-1. Power Selection Settings for TB84H5


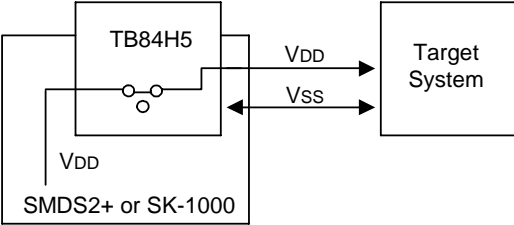

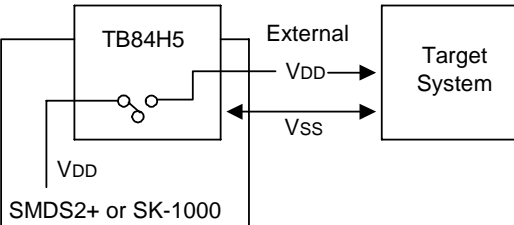
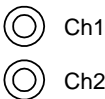
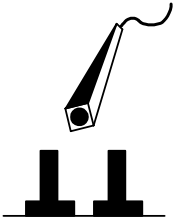
To User_Vcc' Settings	Operating Mode	Comments
To User_VDD Off  On		SMDS2+ or SK-1000 supplies V_{DD} to the target board (evaluation chip) and the target system.
To User_VDD Off  On		SMDS2+ or SK-1000 supplies V_{DD} only to the target board (evaluation chip). The target system must have a power supply of its own.

Table 22-2. Using Single Header Pins as the Input Path for External Trigger Sources

Target Board Part	Comments
External Triggers 	 <p>Connector from External Trigger Sources of the Application System</p> <p>You can connect an external trigger source to one of the two external trigger channels (CH1 or CH2) for the SMDS2+ breakpoint and trace functions.</p>

IDLE LED

This LED is ON when the evaluation chip (S3E84I0) is in idle mode.

STOP LED

This LED is ON when the evaluation chip (S3E84I0) is in stop mode.

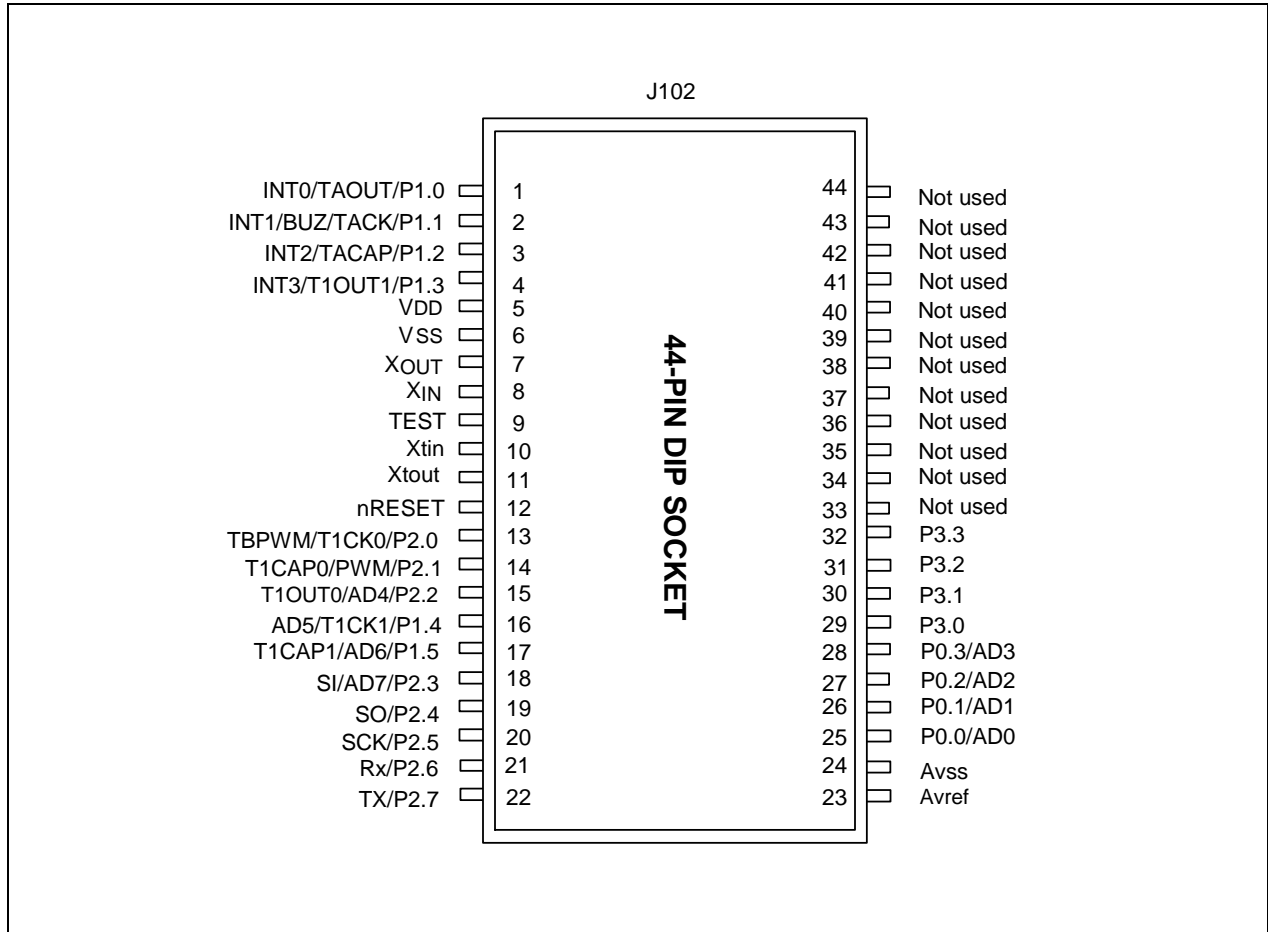


Figure 22-3. 44-Pin Connector pin assignment for TB84H5

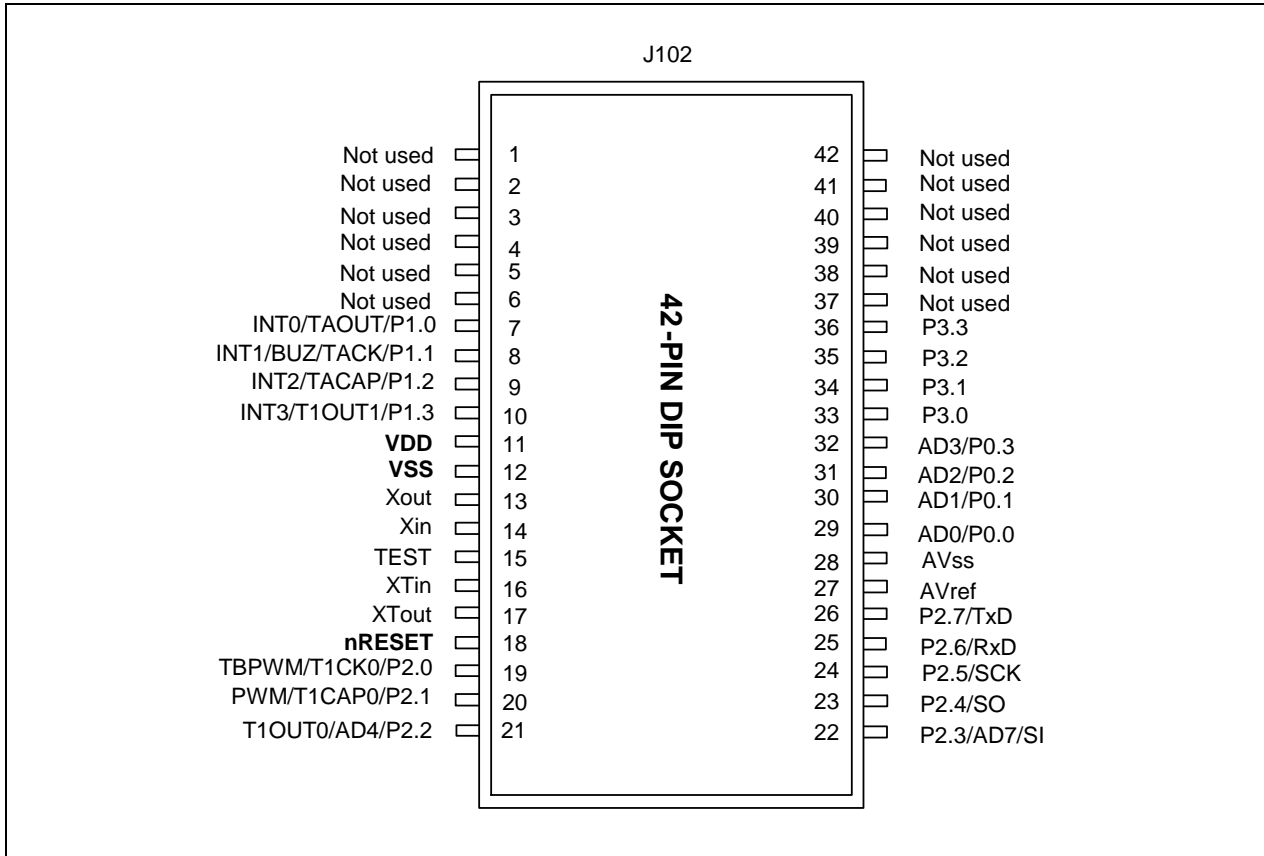


Figure 22-4. 42-Pin Connector Pin Assignment for TB84H5

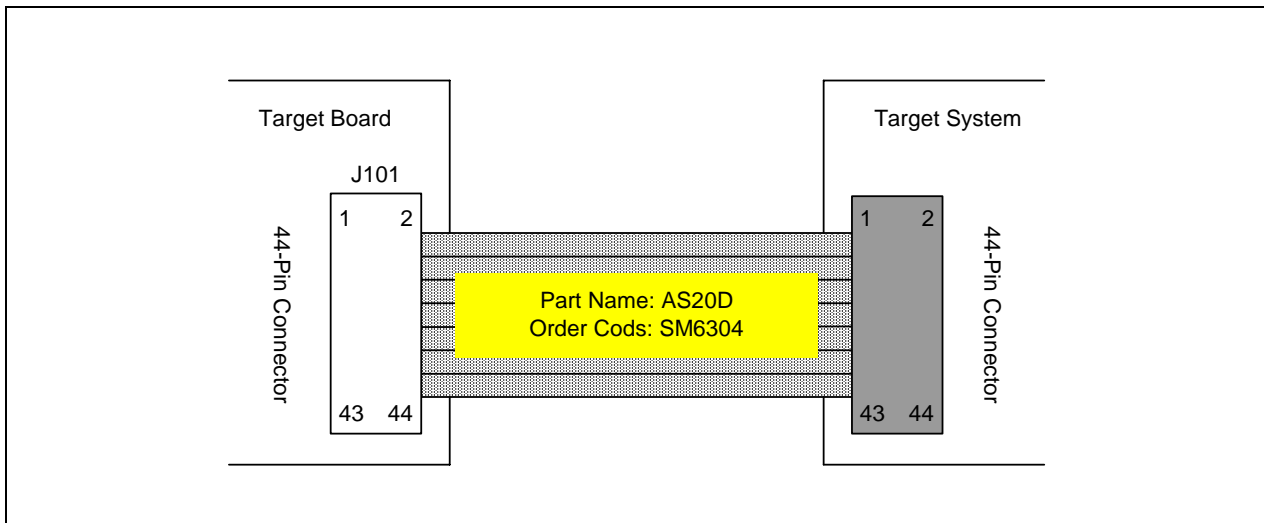


Figure 22-5. TB84H5 Adapter Cable for 44pin Connector Package

S3C8- SERIES MASK ROM ORDER FORM

Product description:

Device Number: S3C8____-_____ (write down the ROM code number)

Product Order Form: Package Pellet Wafer Package Type: _____

Package Marking (Check One):

Standard

Custom A
(Max 10 chars)

Custom B
(Max 10 chars each line)

SEC @ YWW Device Name	
---------------------------------	--

@ YWW Device Name <input style="width: 100%;" type="text"/>	
---	--

@ YWW <input style="width: 100%;" type="text"/> <input style="width: 100%;" type="text"/>	
---	--

@ : Assembly site code, Y : Last number of assembly year, WW : Week of assembly

Delivery Dates and Quantities:

Deliverable	Required Delivery Date	Quantity	Comments
ROM code	-	Not applicable	See ROM Selection Form
Customer sample			
Risk order			See Risk Order Sheet

Please answer the following questions:

☛ For what kind of product will you be using this order?

- | | |
|---|---|
| <input type="checkbox"/> New model | <input type="checkbox"/> Upgrade of an existing model |
| <input type="checkbox"/> Replacement of an existing model | <input type="checkbox"/> Others |

If you are replacing an existing model, please indicate the former product name
(_____)

☛ What are the main reasons you decided to use a Samsung microcontroller in your product?

Please check all that apply.

- | | | |
|---|---|---|
| <input type="checkbox"/> Price | <input type="checkbox"/> Product quality | <input type="checkbox"/> Features and functions |
| <input type="checkbox"/> Development system | <input type="checkbox"/> Technical support | <input type="checkbox"/> Delivery on time |
| <input type="checkbox"/> Used same MCU before | <input type="checkbox"/> Quality of documentation | <input type="checkbox"/> Samsung reputation |

Mask Charge (US\$ / Won): _____

Customer Information:

Company Name: _____ Telephone number _____

Signatures: _____ (Person placing the order) _____ (Technical Manager)

(For duplicate copies of this form, and for additional ordering information, please contact your local Samsung sales representative. Samsung sales offices are listed on the back cover of this book.)

S3C8- SERIES REQUEST FOR PRODUCTION AT CUSTOMER RISK

Customer Information:

Company Name: _____

Department: _____

Telephone Number: _____ Fax: _____

Date: _____

Risk Order Information:

Device Number: S3C8____- _____ (write down the ROM code number)

Package: _____ Number of Pins: _____ Package Type: _____

Intended Application: _____

Product Model Number: _____

Customer Risk Order Agreement:

We hereby request SEC to produce the above named product in the quantity stated below. We believe our risk order product to be in full compliance with all SEC production specifications and, to this extent, agree to assume responsibility for any and all production risks involved.

Order Quantity and Delivery Schedule:

Risk Order Quantity: _____ PCS

Delivery Schedule:

Delivery Date (s)	Quantity	Comments

Signatures: _____ (Person Placing the Risk Order) _____ (SEC Sales Representative)

(For duplicate copies of this form, and for additional ordering information, please contact your local Samsung sales representative. Samsung sales offices are listed on the back cover of this book.)

S3C84I8/C84I9 MASK OPTION SELECTION FORM

Device Number: S3C8____-_____(write down the ROM code number)


Attachment (Check one): Diskette PROM

Customer Checksum: _____

Company Name: _____

Signature (Engineer): _____

Please answer the following questions:

 **Application** (Product Model ID: _____)

- | | | |
|---------------------------------------|---|--|
| <input type="checkbox"/> Audio | <input type="checkbox"/> Video | <input type="checkbox"/> Telecom |
| <input type="checkbox"/> LCD Databank | <input type="checkbox"/> Caller ID | <input type="checkbox"/> LCD Game |
| <input type="checkbox"/> Industrials | <input type="checkbox"/> Home Appliance | <input type="checkbox"/> Office Automation |
| <input type="checkbox"/> Remocon | <input type="checkbox"/> Other | |

Please describe in detail its application
