

1

PRODUCT OVERVIEW

SAM88RCRI PRODUCT FAMILY

Samsung's SAM88RCRI family of 8-bit single-chip CMOS microcontrollers offers a fast and efficient CPU, a wide range of integrated peripherals, and various mask-programmable ROM sizes.

A address/data bus architecture and a large number of bit-configurable I/O ports provide a flexible programming environment for applications with varied memory and I/O requirements. Timer/counters with selectable operating modes are included to support real-time operations.

S3C9442/C9444/C9452/C9454 MICROCONTROLLER

The S3C9442/C9444/C9452/C9454 single-chip 8-bit microcontroller is designed for useful A/D converter , SIO application field. The S3C9442/C9444/C9452/C9454 uses powerful SAM88RCRI CPU and S3C9442/C9444/C9452/C9454 architecture. The internal register file is logically expanded to increase the on-chip register space.

The S3C9442/C9444/C9452/C9454 has 2K/4K bytes of on-chip program ROM and 208 bytes of RAM. The S3C9442/C9444/C9452/C9454 is a versatile general-purpose microcontroller that is ideal for use in a wide range of electronics applications requiring simple timer/counter, PWM. In addition, the S3C9442/C9444/C9452/C9454's advanced CMOS technology provides for low power consumption and wide operating voltage range.

Using the SAM88RCRI design approach, the following peripherals were integrated with the SAM88RCRI core:

- Three configurable I/O ports (18 pins)
- Four interrupt sources with one vector and one interrupt level
- One 8-bit timer/counter with time interval mode
- Analog to digital converter with nine input channels and 10-bit resolution
- One 8-bit PWM output

The S3C9442/C9444/C9452/C9454 microcontroller is ideal for use in a wide range of electronic applications requiring simple timer/counter, PWM, ADC. S3C9452/C9454 is available in a 20/16-pin DIP and a 20-pin SOP package. S3C9452/C9454 is available in a 8-pin and a 8-pin SOP package.

MTP

The S3F9444/F9454 is an MTP (Multi Time Programmable) version of the S3C9442/C9444/C9452/C9454 microcontroller. The S3F9444/F9454 has on-chip 4-Kbyte multi-time programmable flash ROM instead of masked ROM. The S3F9444/F9454 is fully compatible with the S3C9442/C9444/C9452/C9454, in function, in D.C. electrical characteristics and in pin configuration.

FEATURES

CPU

- SAM88RCRI CPU core
- The SAM88RCRI core is low-end version of the current SAM87 core.

Memory

- 2/4-Kbyte internal program memory
- 208-byte general purpose register area

Instruction Set

- 41 instructions
- The SAM88RCRI core provides all the SAM87 core instruction except the word-oriented instruction, multiplication, division, and some one-byte instruction.

Instruction Execution Time

- 400 ns at 10 MHz f_{OSC} (minimum)

Interrupts

- 4 interrupt sources with one vector
- One interrupt level

General I/O

- Three I/O ports (Max 18 pins)
- Bit programmable ports

8-bit High-speed PWM

- 8-bit PWM 1-ch (Max: 156 kHz)
- 6-bit base + 2-bit extension

Built-in reset Circuit

- Low voltage detector for safe reset

Timer/Counters

- One 8-bit basic timer for watchdog function
- One 8-bit timer/counter with time interval modes

A/D Converter

- Nine analog input pins
- 10-bit conversion resolution

Oscillation Frequency

- 1 MHz to 10 MHz external crystal oscillator
- Maximum 10 MHz CPU clock
- Internal RC: 3.2 MHz (typ.), 0.5 MHz (typ.) in $V_{DD} = 5\text{ V}$

Operating Temperature Range

- -40°C to $+85^{\circ}\text{C}$

Operating Voltage Range

- 2.0 V (LVR Level) to 5.5 V

Smart Option

Package Types

- S3C9452/C9454:
 - 20-DIP-300A
 - 20-SOP-375
 - 16-DIP-300A
- S3C9442/C9444
 - 8-DIP-300
 - 8-SOP-225

BLOCK DIAGRAM

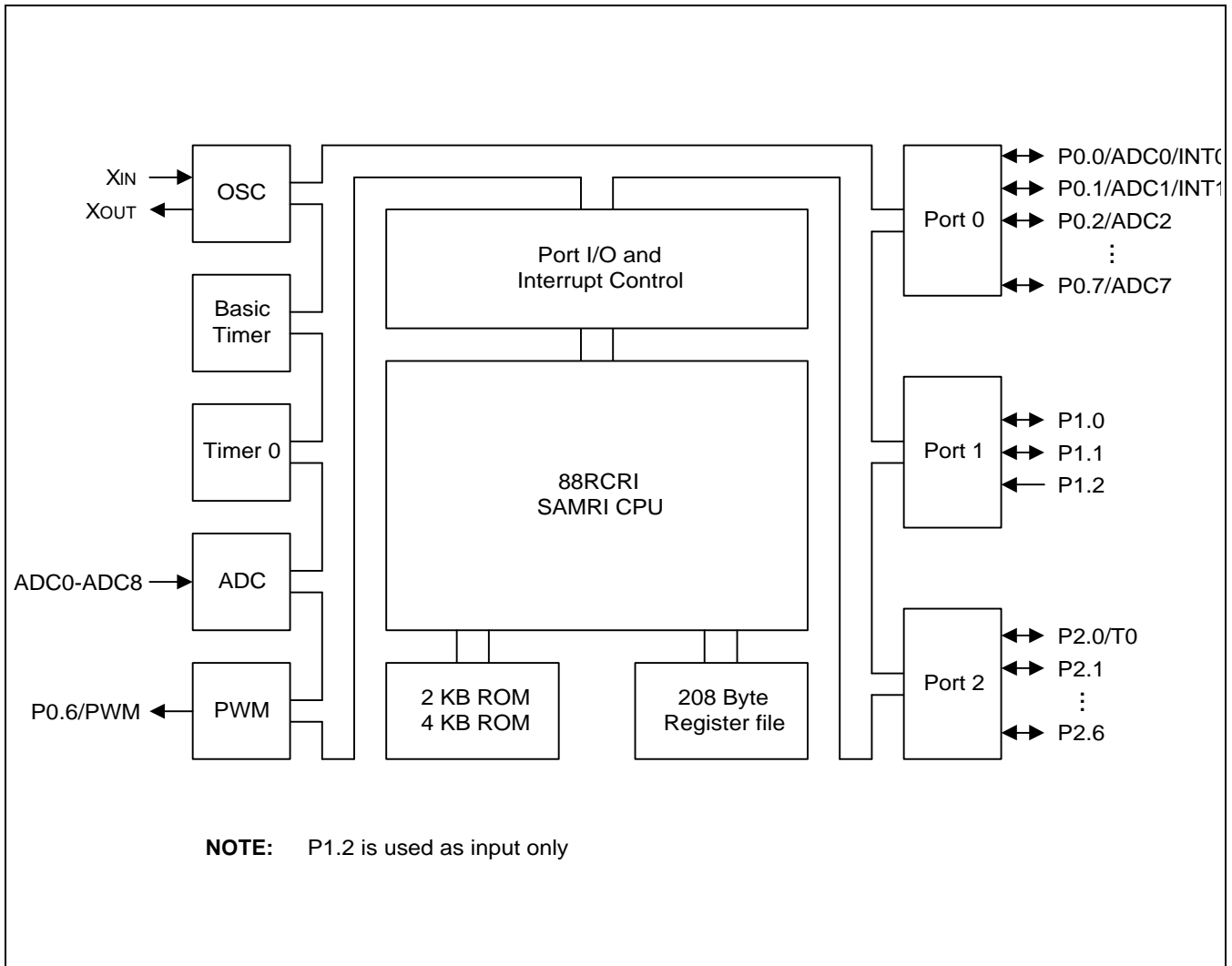


Figure 1-1. Block Diagram

PIN ASSIGNMENTS

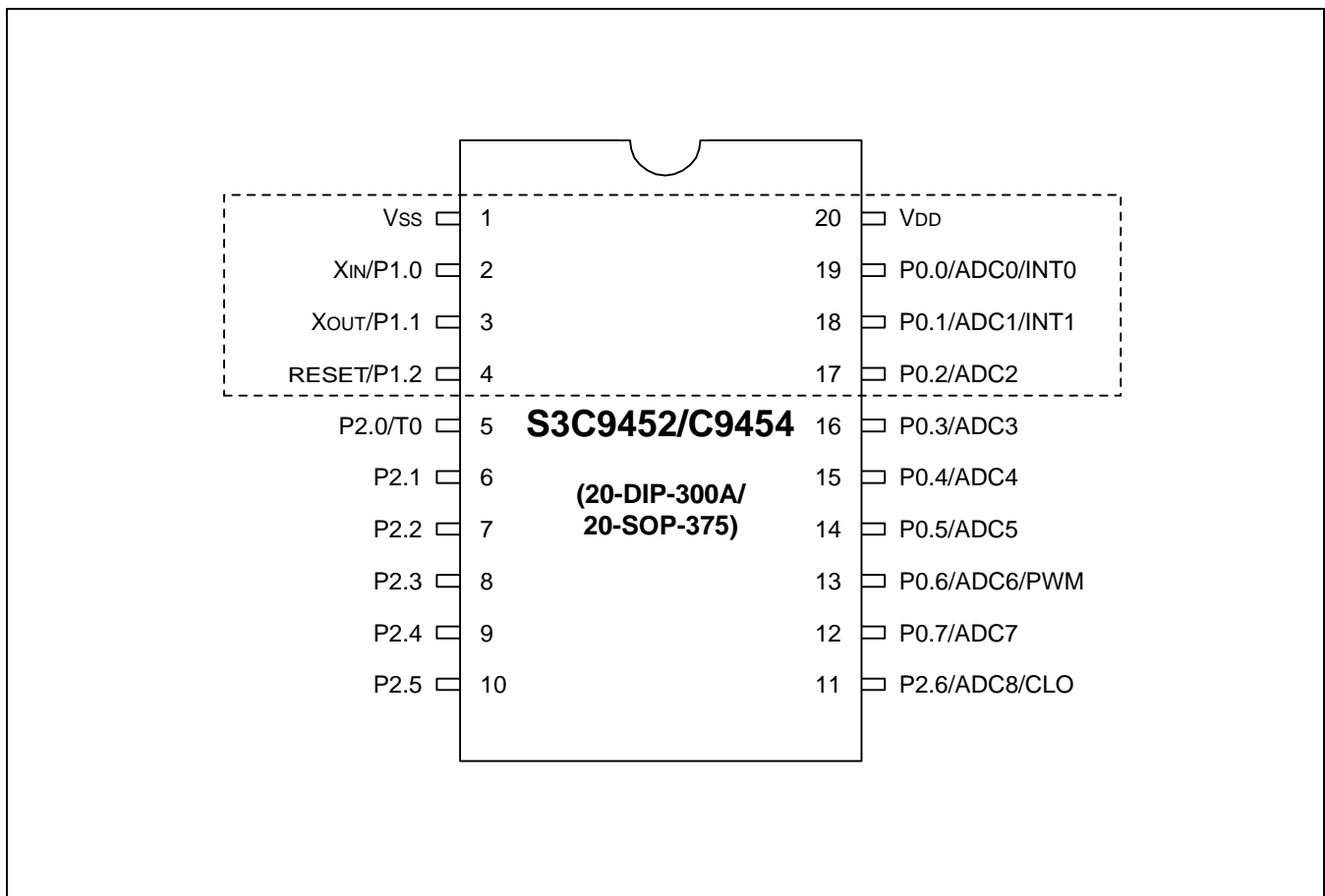


Figure 1-2. Pin Assignment Diagram (20-Pin DIP/SOP Package)

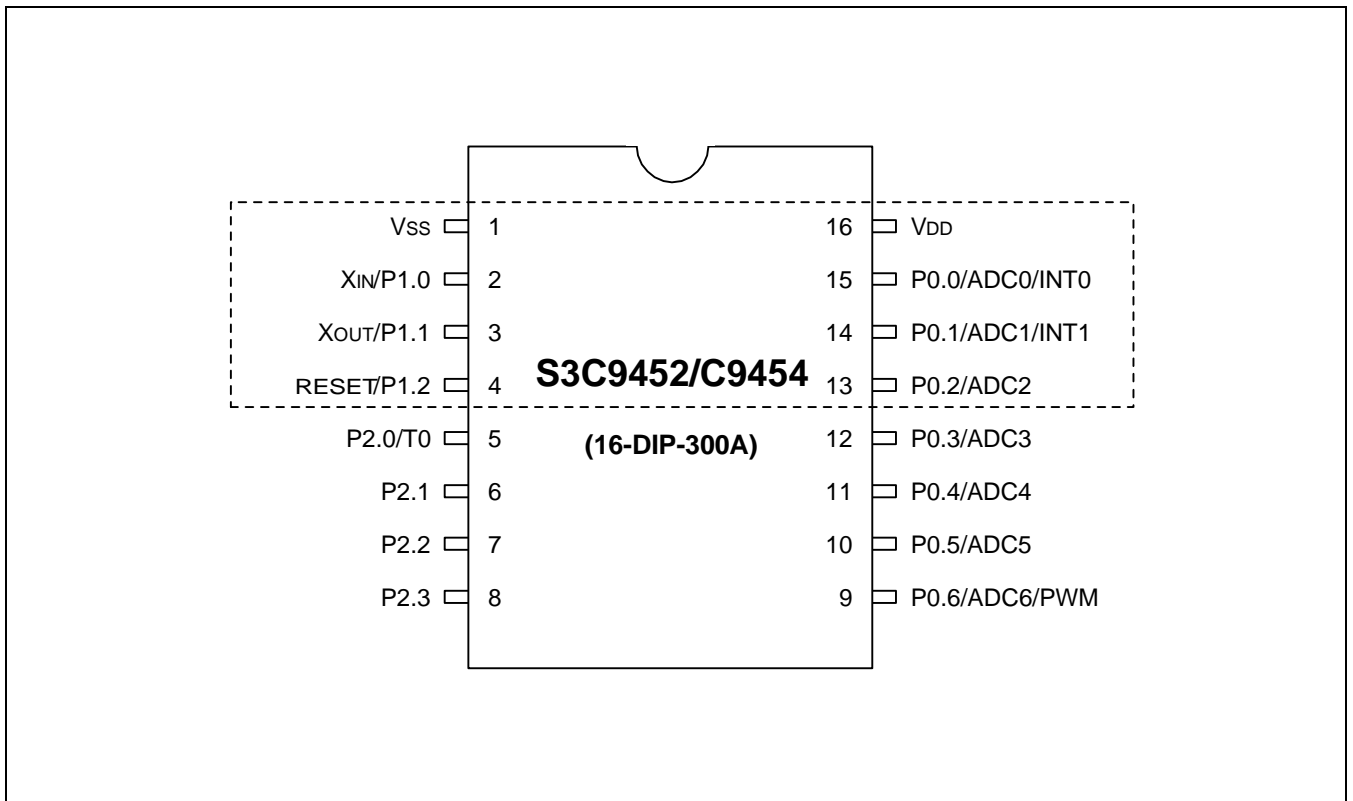


Figure 1-3. Pin Assignment Diagram (16-Pin DIP Package)

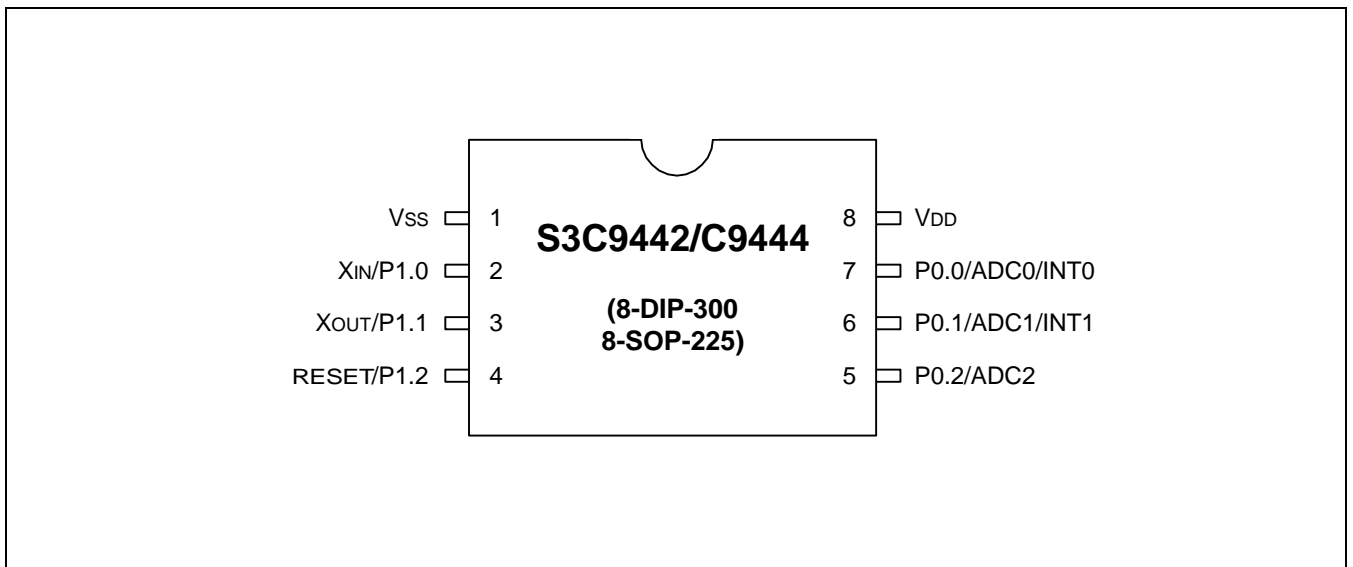


Figure 1-4. Pin Assignment Diagram (8-Pin DIP/SOP Package)

PIN DESCRIPTIONS

Table 1-1. S3C9452/C9454 Pin Descriptions

Pin Name	In/Out	Pin Description	Pin Type	Share Pins
P0.0–P0.7	I/O	Bit-programmable I/O port for Schmitt trigger input or push-pull output. Pull-up resistors are assignable by software. Port0 pins can also be used as A/D converter input, PWM output or external interrupt input.	E-1	ADC0–ADC7 INT0/INT1 PWM
P1.0–P1.1	I/O	Bit-programmable I/O port for Schmitt trigger input or push-pull, open-drain output. Pull-up resistors or pull-down resistors are assignable by software.	E-2	X_{IN} , X_{OUT}
P1.2	I	Schmitt trigger input port	B	RESET
P2.0–P2.6	I/O	Bit-programmable I/O port for Schmitt trigger input or push-pull, open-drain output. Pull-up resistors are assignable by software.	E E-1	– ADC8/CLO T0
X_{IN} , X_{OUT}	–	Crystal/Ceramic, or RC oscillator signal for system clock.		P1.0–P1.1
RESET	I	Internal LVR or External RESET	B	P1.2
V_{DD} , V_{SS}	–	Voltage input pin and ground		–
CLO	O	System clock output port	E-1	P2.6
INT0–INT1	I	External interrupt input port	E-1	P0.0, P0.1
PWM	O	8-Bit high speed PWM output	E-1	P0.6
T0	O	Timer0 match output	E-1	P2.0
ADC0–ADC8	I	A/D converter input	E-1 E	P0.0–P0.7 P2.6

PIN CIRCUITS

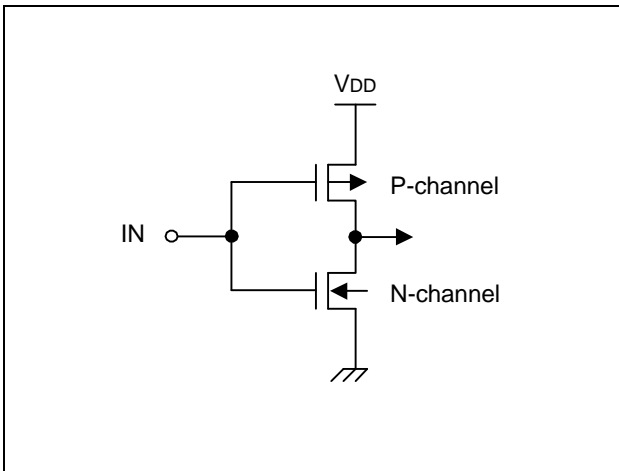


Figure 1-5. Pin Circuit Type A

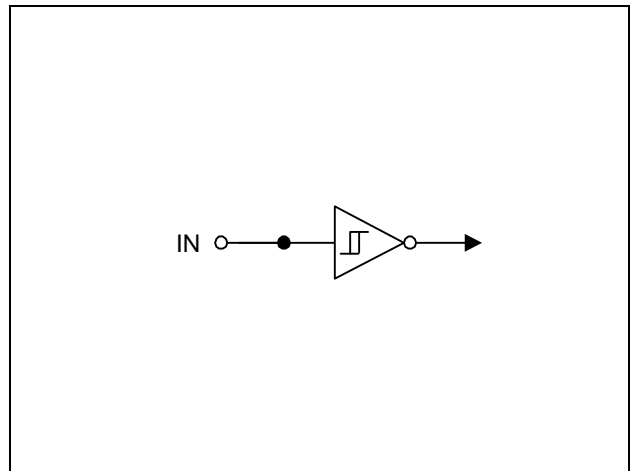


Figure 1-6. Pin Circuit Type B

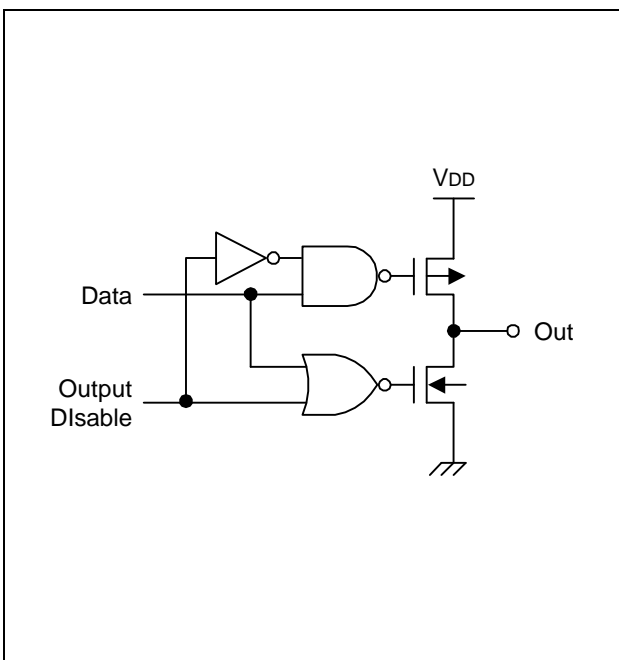


Figure 1-7. Pin Circuit Type C

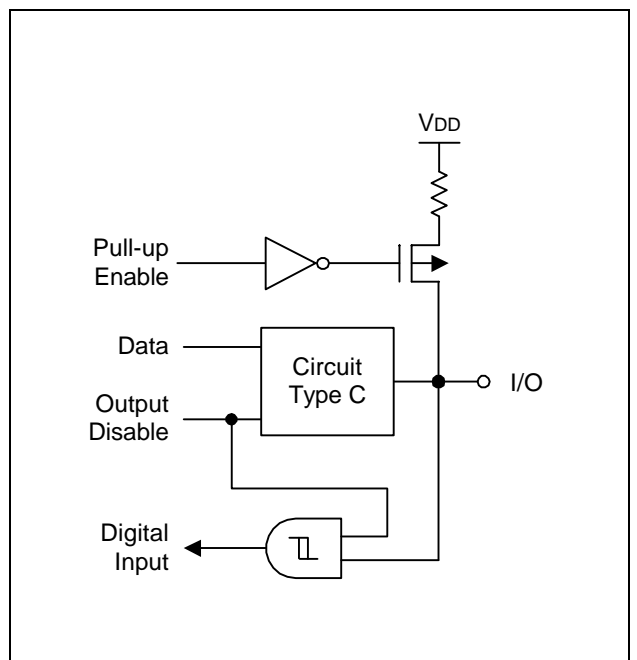


Figure 1-8. Pin Circuit Type D

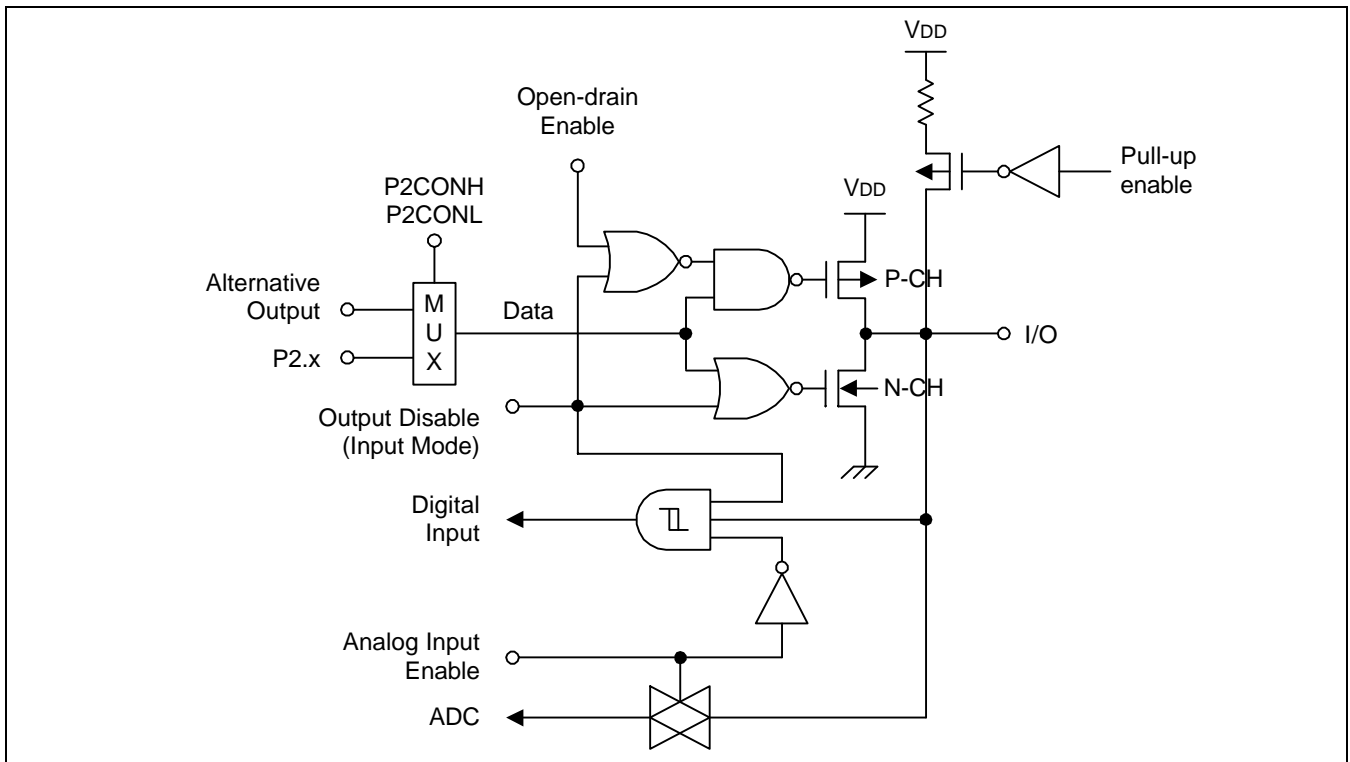


Figure 1-9. Pin Circuit Type E

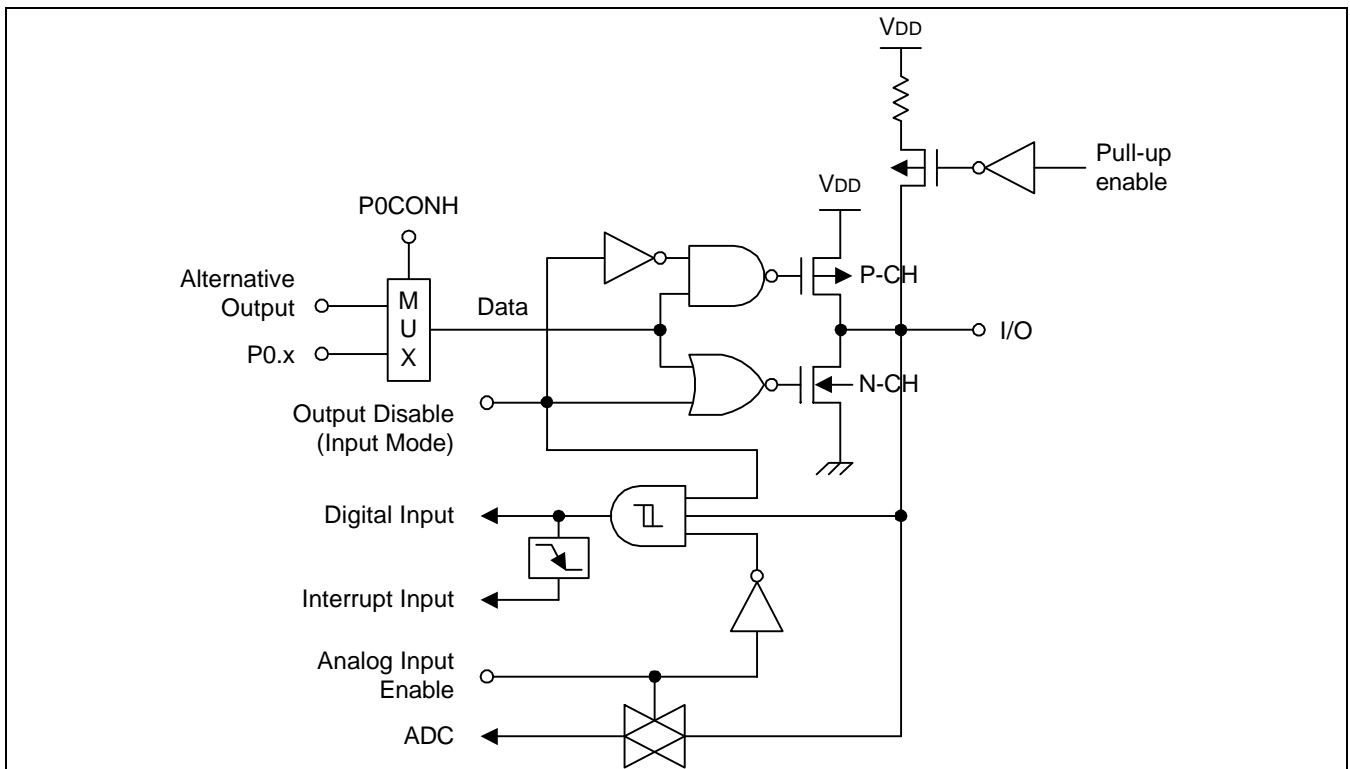


Figure 1-10. Pin Circuit Type E-1

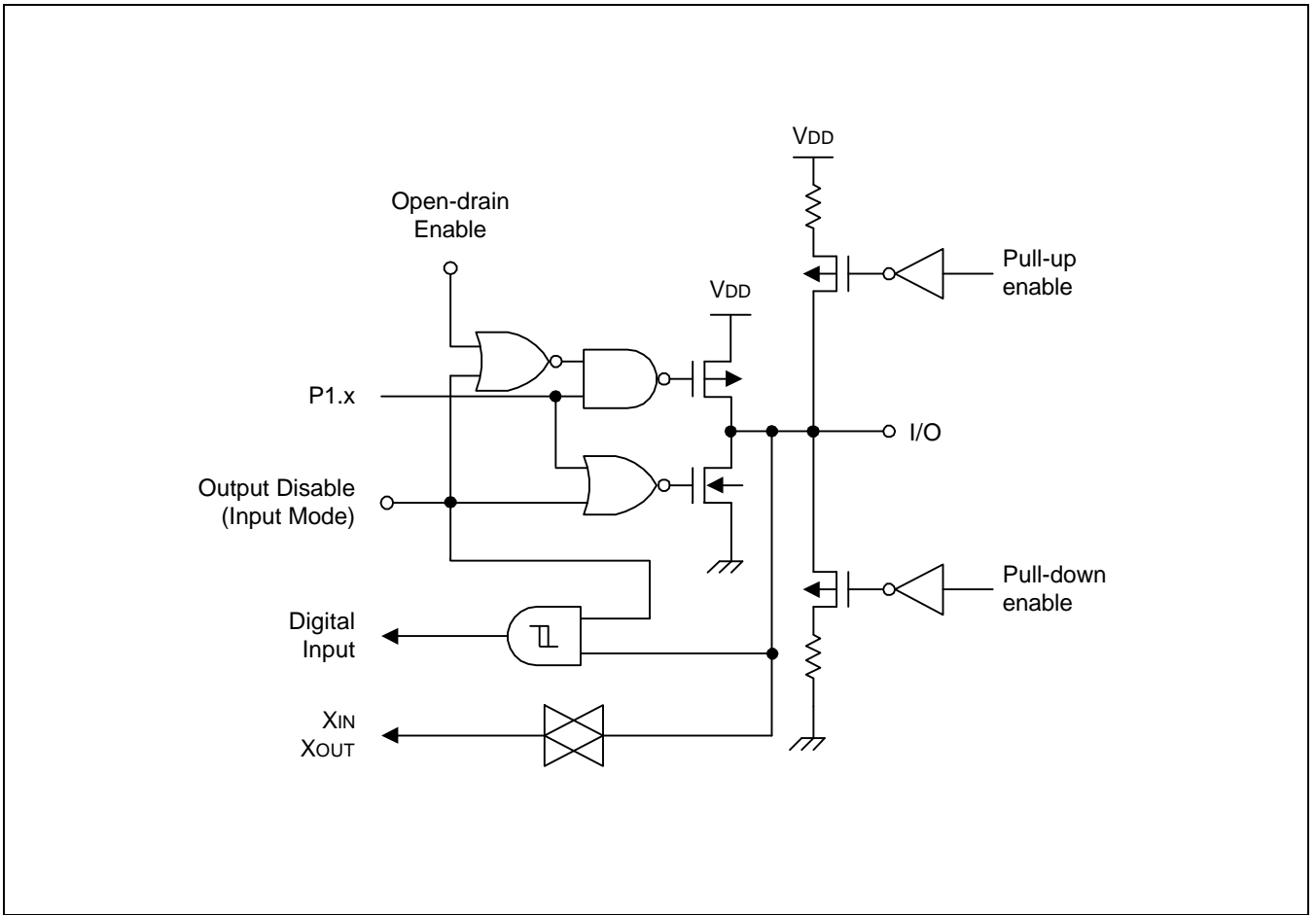


Figure 1-11. Pin Circuit Type E-2

2 ADDRESS SPACES

OVERVIEW

The S3C9442/C9444/C9452/C9454 microcontroller has two kinds of address space:

- Internal program memory (ROM)
- Internal register file

A 12-bit address bus supports program memory operations. A separate 8-bit register bus carries addresses and data between the CPU and the internal register file.

The S3C9442/C9444/C9452/C9454 have 2-Kbytes or 4-Kbytes of mask-programmable on-chip program memory: which is configured as the Internal ROM mode, all of the 4-Kbyte internal program memory is used.

The S3C9442/C9444/C9452/C9454 microcontroller has 208 general-purpose registers in its internal register file. Twenty-six bytes in the register file are mapped for system and peripheral control functions.

PROGRAM MEMORY (ROM)

Normal Operating Mode

The S3C9442/C9444/C9452/C9454 have 2-Kbytes (locations 0H–07FFH) or 4-Kbytes (locations 0H–0FFFH) of internal mask-programmable program memory.

The first 2-bytes of the ROM (0000H–0001H) are interrupt vector address.

Unused locations (0002H–00FFH except 3CH, 3DH, 3EH, 3FH) can be used as normal program memory. 3CH, 3DH, 3EH, 3FH is used smart option ROM cell.

The program reset address in the ROM is 0100H.

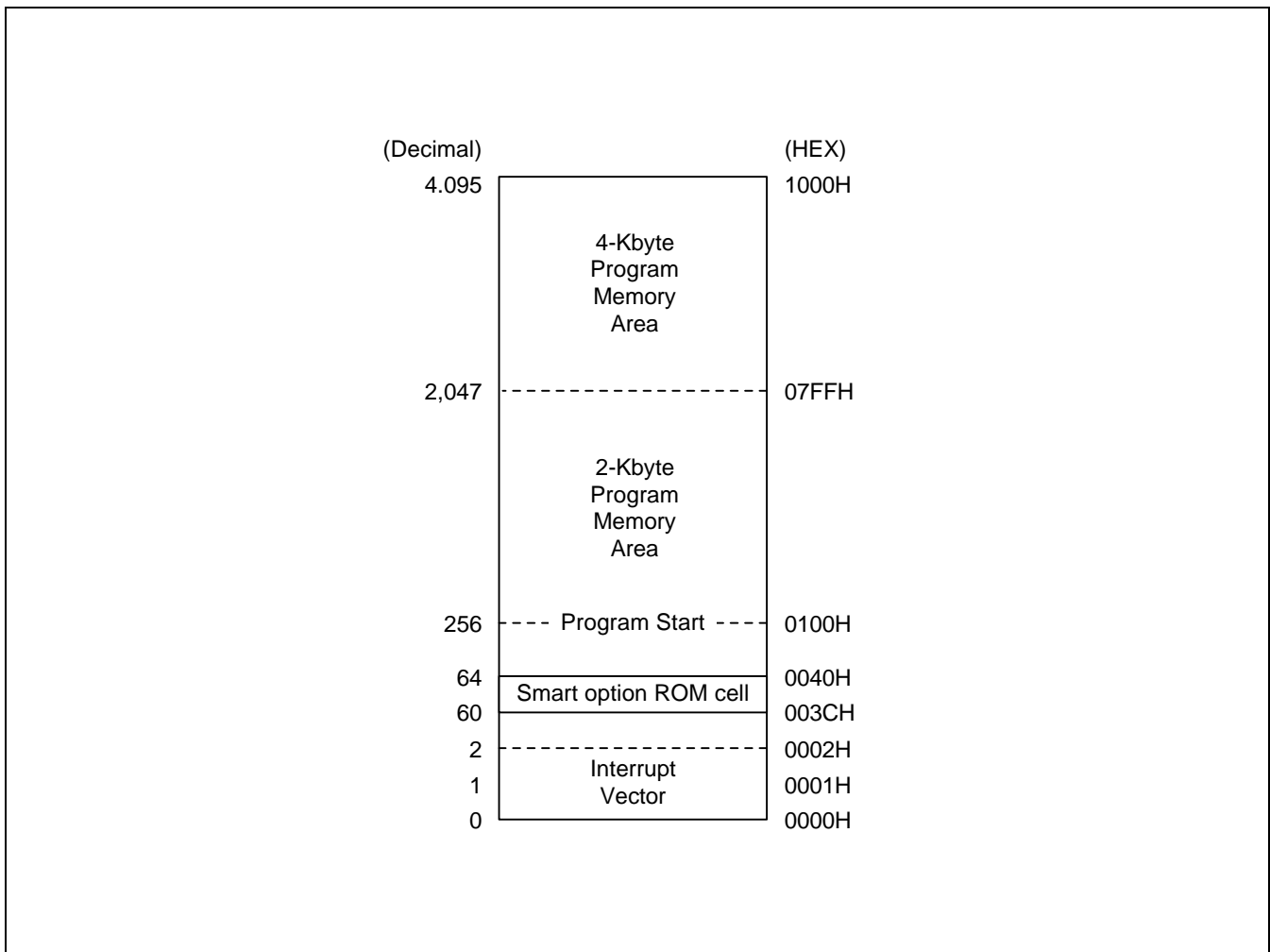


Figure 2-1. Program Memory Address Space

Smart Option

Smart option is the ROM option for starting condition of the chip.

The ROM addresses used by smart option are from 003CH to 003FH. The S3C9442/C9444/C9452/9454 only use 003EH, 003FH. Not used ROM address 003CH, 003DH should be initialized to be initialized to 00H. The default value of ROM is FFH (LVR enable, internal RC oscillator).

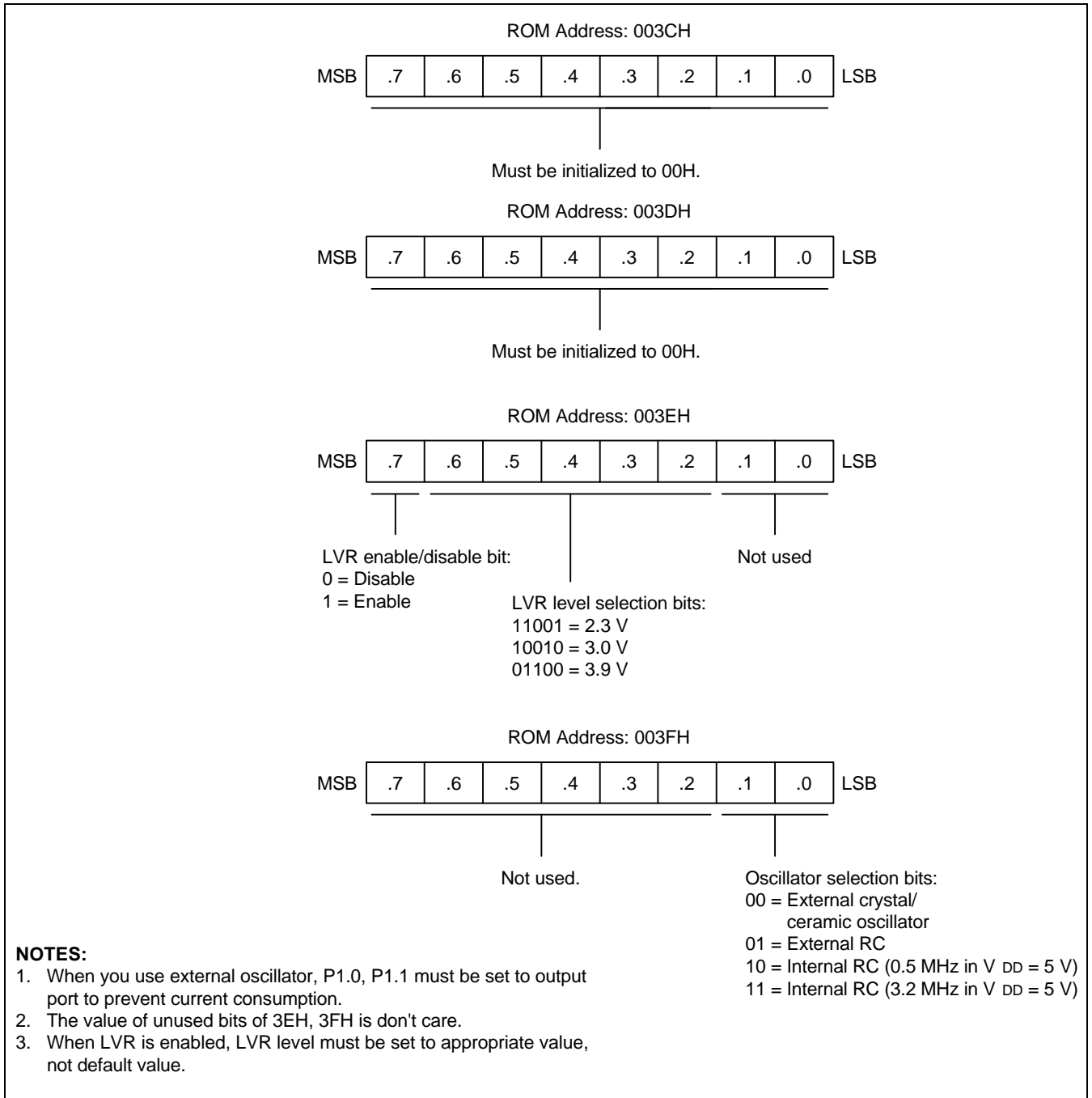


Figure 2-2. Smart Option

PROGRAMMING TIP — Smart Option Setting

```
;      << Interrupt Vector Address >>

      ORG      0000H
      Vector   00H, INT_9454      ; S3C9454 has only one interrupt vector

;      << Smart Option Setting >>

      ORG      003CH
      DB       00H                ; 003CH, must be initialized to 0.
      DB       00H                ; 003DH, must be initialized to 0.
      DB       0E7H               ; 003EH, enable LVR (2.3 V)
      DB       03H                ; 003FH, Internal RC (3.2 MHz in VDD = 5 V)

;      << Reset >>

      ORG      0100H
      RESET;   DI
               .
               .
               .
```

REGISTER ARCHITECTURE

The upper 64-bytes of the S3C9442/C9444/C9452/C9454's internal register file are addressed as working registers, system control registers and peripheral control registers. The lower 192-bytes of internal register file(00H–BFH) is called the *general purpose register space*. 234 registers in this space can be accessed; 208 are available for general-purpose use.

For many SAM88RCRI microcontrollers, the addressable area of the internal register file is further expanded by additional register pages at the general purpose register space (00H–BFH: page0). This register file expansion is not implemented in the S3C9442/C9444/C9452/C9454, however.

The specific register types and the area (in bytes) that they occupy in the internal register file are summarized in Table 2-1.

Table 2-1. Register Type Summary

Register Type	Number of Bytes
CPU and system control registers	11
Peripheral, I/O, and clock control and data registers	15
General-purpose registers (including the 16-bit common working register area)	208
Total Addressable Bytes	234

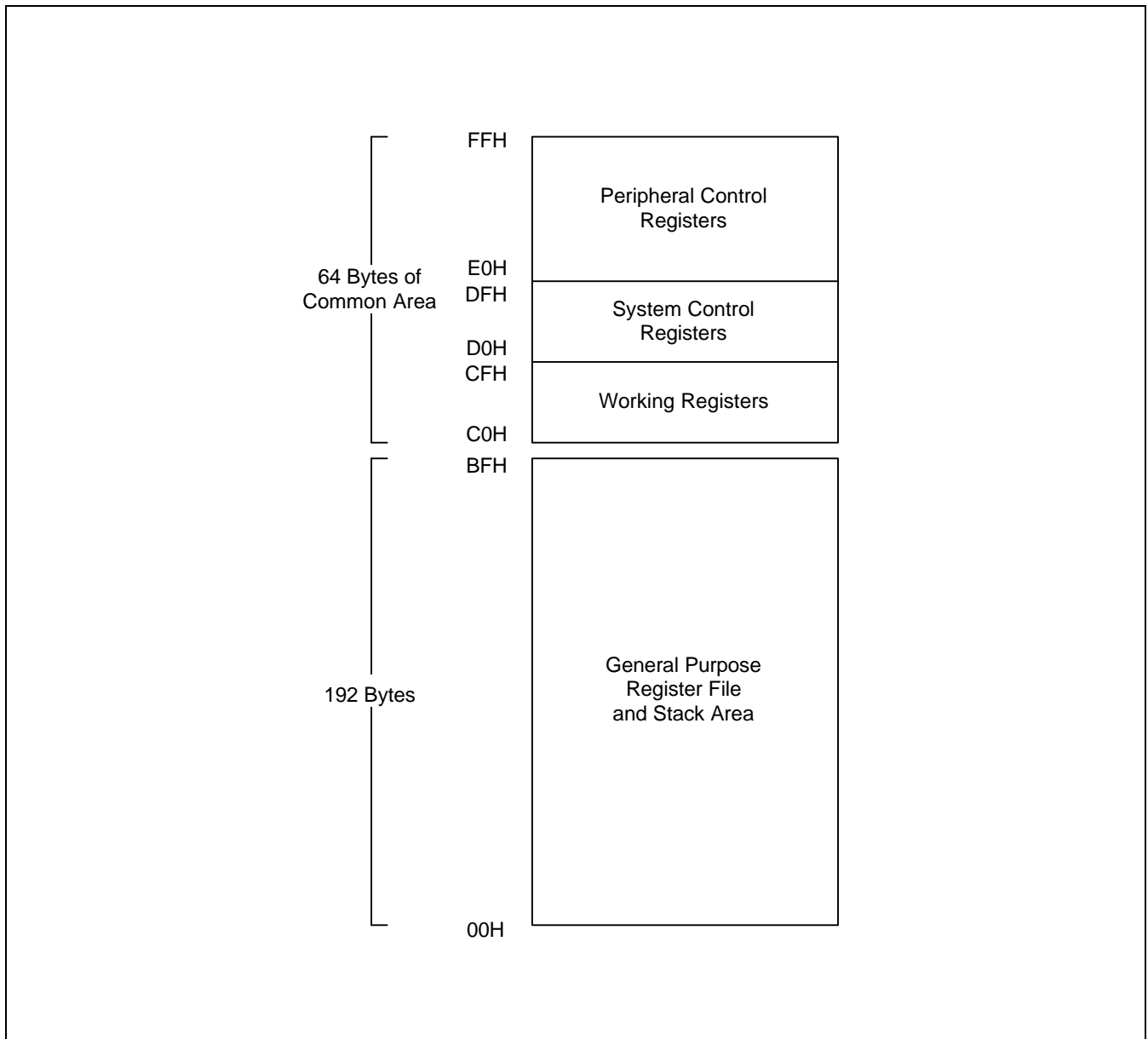


Figure 2-3. Internal Register File Organization

COMMON WORKING REGISTER AREA (C0H–CFH)

The SAM88RCRI register architecture provides an efficient method of working register addressing that takes full advantage of shorter instruction formats to reduce execution time.

This 16-byte address range is called common area. That is, locations in this area can be used as working registers by operations that address any location on any page in the register file. Typically, these working registers serve as temporary buffers for data operations between different pages. However, because the S3C9442/C9444/C9452/C9454 uses only page 0, you can use the common area for any internal data operation.

The Register (R) addressing mode can be used to access this area

Registers are addressed either as a single 8-bit register or as a paired 16-bit register. In 16-bit register pairs, the address of the first 8-bit register is always an even number and the address of the next register is an odd number. The most significant byte of the 16-bit data is always stored in the even-numbered register; the least significant byte is always stored in the next (+ 1) odd-numbered register.

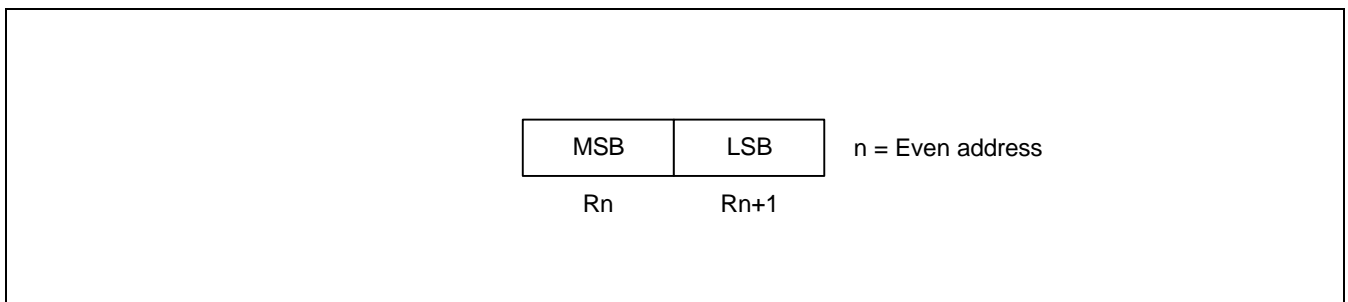


Figure 2-4. 16-Bit Register Pairs

PROGRAMMING TIP — Addressing the Common Working Register Area

As the following examples show, you should access working registers in the common area, locations C0H–CFH, using working register addressing mode only.

- Examples:**
1. LD 0C2H,40H ; Invalid addressing mode!
 Use working register addressing instead:
 LD R2,40H ; R2 (C2H) ← the value in location 40H
 2. ADD 0C3H,#45H ; Invalid addressing mode!
 Use working register addressing instead:
 ADD R3,#45H ; R3 (C3H) ← R3 + 45H

SYSTEM STACK

S3C9-series microcontrollers use the system stack for subroutine calls and returns and to store data. The PUSH and POP instructions are used to control system stack operations. The S3C9442/C9444/C9452/C9454 architecture supports stack operations in the internal register file.

Stack Operations

Return addresses for procedure calls and interrupts and data are stored on the stack. The contents of the PC are saved to stack by a CALL instruction and restored by the RET instruction. When an interrupt occurs, the contents of the PC and the FLAGS register are pushed to the stack. The IRET instruction then pops these values back to their original locations. The stack address is always decremented *before* a push operation and incremented *after* a pop operation. The stack pointer (SP) always points to the stack frame stored on the top of the stack, as shown in Figure 2-4.

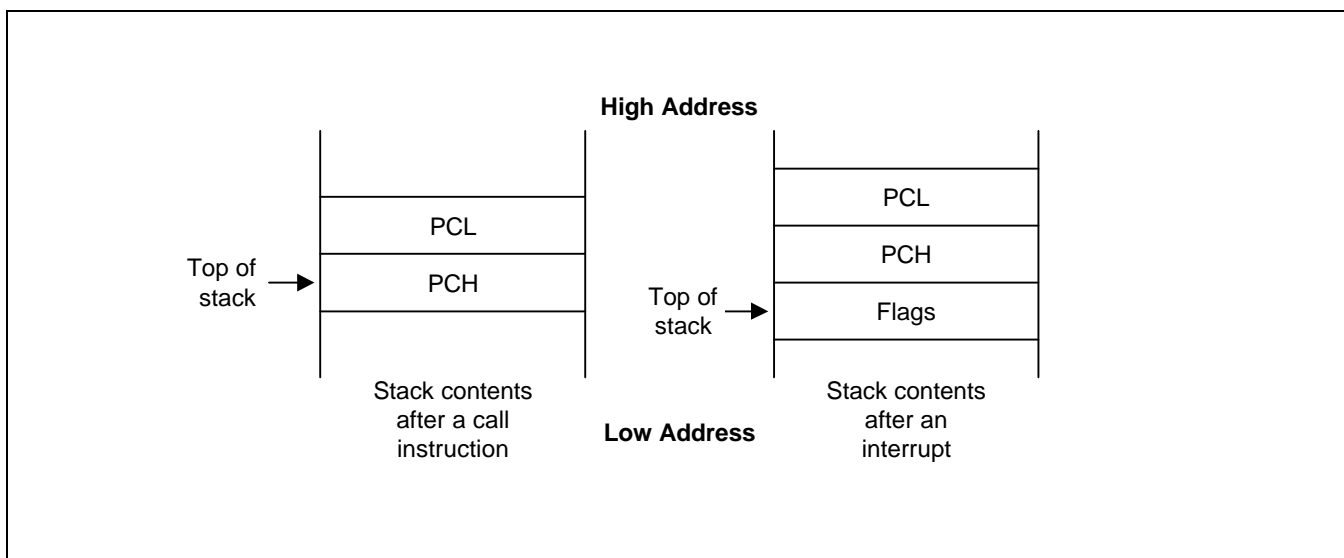


Figure 2-5. Stack Operations

Stack Pointer (SP)

Register location D9H contains the 8-bit stack pointer (SP) that is used for system stack operations. After a reset, the SP value is undetermined.

Because only internal memory space is implemented in the S3C9442/C9444/C9452/C9454, the SP must be initialized to an 8-bit value in the range 00H–0C0H.

NOTE

In case a Stack Pointer is initialized to 00H, it is decreased to FFH when stack operation starts. This means that a Stack Pointer access invalid stack area. We recommend that a stack pointer is initialized to C0H to set upper address of stack to BFH.

 **PROGRAMMING TIP — Standard Stack Operations Using PUSH and POP**

The following example shows you how to perform stack operations in the internal register file using PUSH and POP instructions:

```

LD      SP,#0C0H      ; SP ← C0H (Normally, the SP is set to C0H by the
                    ; initialization routine)
.
.
.
PUSH   SYM           ; Stack address 0BFH ← SYM
PUSH   R15           ; Stack address 0BEH ← R15
PUSH   20H           ; Stack address 0BDH ← 20H
PUSH   R3            ; Stack address 0BCH ← R3
.
.
.
POP    R3            ; R3 ← Stack address 0BCH
POP    20H           ; 20H ← Stack address 0BDH
POP    R15           ; R15 ← Stack address 0BEH
POP    SYM           ; SYM ← Stack address 0BFH

```

3

ADDRESSING MODES

OVERVIEW

Instructions that are stored in program memory are fetched for execution using the program counter. Instructions indicate the operation to be performed and the data to be operated on. *Addressing mode* is the method used to determine the location of the data operand. The operands specified in SAM88RCRI instructions may be condition codes, immediate data, or a location in the register file, program memory, or data memory.

The SAM88RCRI instruction set supports six explicit addressing modes. Not all of these addressing modes are available for each instruction. The addressing modes and their symbols are as follows:

- Register (R)
- Indirect Register (IR)
- Indexed (X)
- Direct Address (DA)
- Relative Address (RA)
- Immediate (IM)

REGISTER ADDRESSING MODE (R)

In Register addressing mode, the operand is the content of a specified register (see Figure 3-1). Working register addressing differs from Register addressing because it uses an 16-byte working register space in the register file and an 4-bit register within that space (see Figure 3-2).

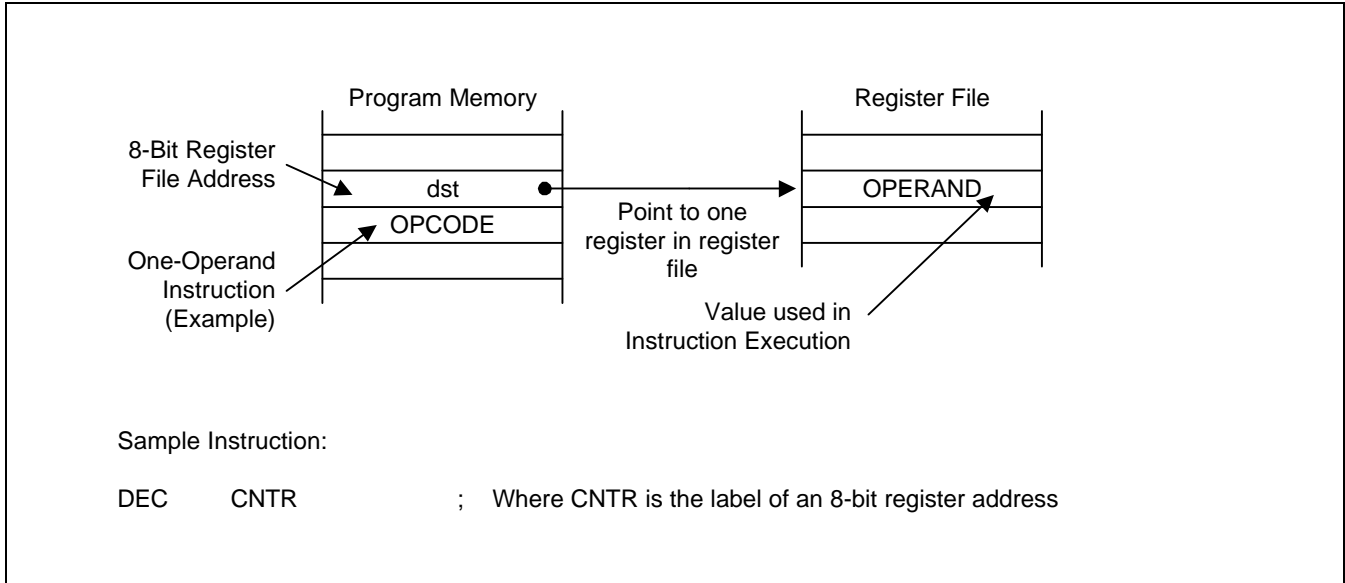


Figure 3-1. Register Addressing

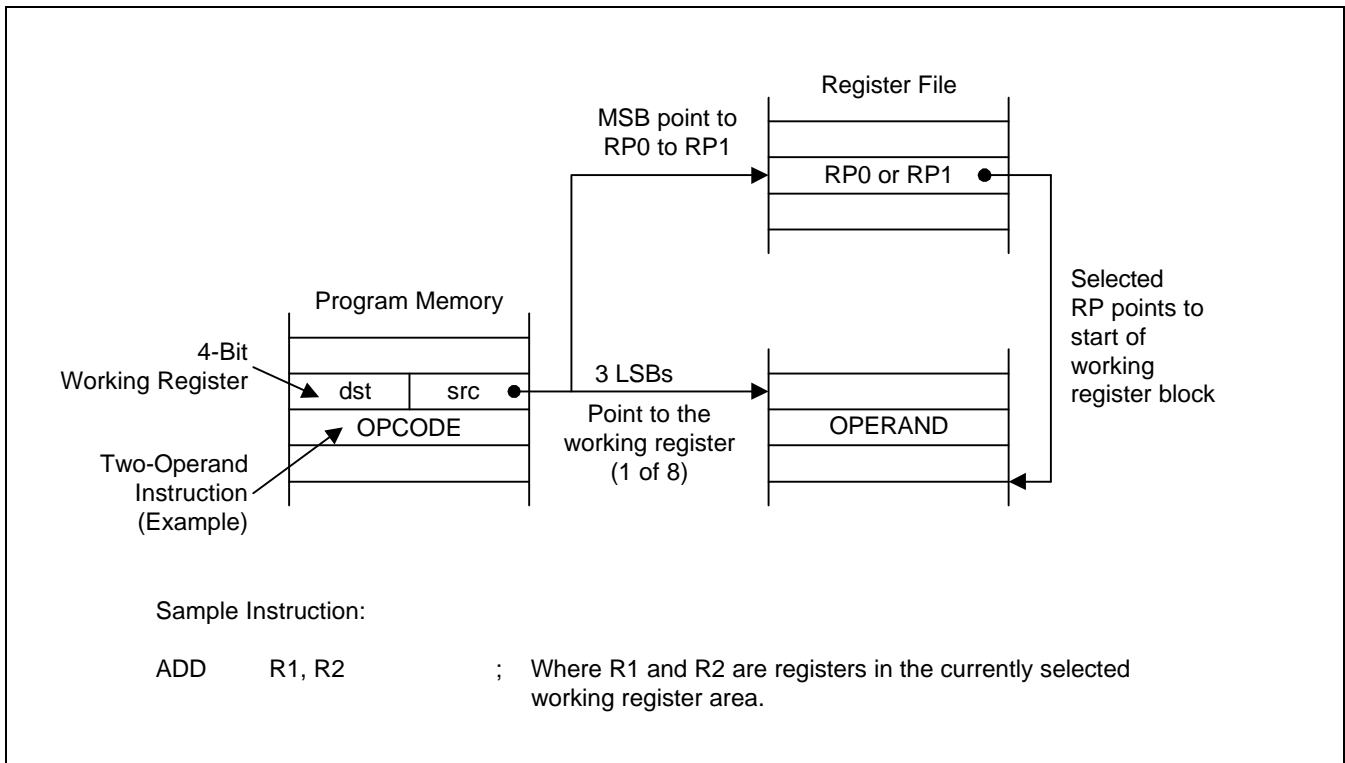


Figure 3-2. Working Register Addressing

INDIRECT REGISTER ADDRESSING MODE (IR)

In Indirect Register (IR) addressing mode, the content of the specified register or register pair is the address of the operand. Depending on the instruction used, the actual address may point to a register in the register file, to program memory (ROM), or to an external memory space (see Figures 3-3 through 3-6).

You can use any 8-bit register to indirectly address another register. Any 16-bit register pair can be used to indirectly address another memory location.

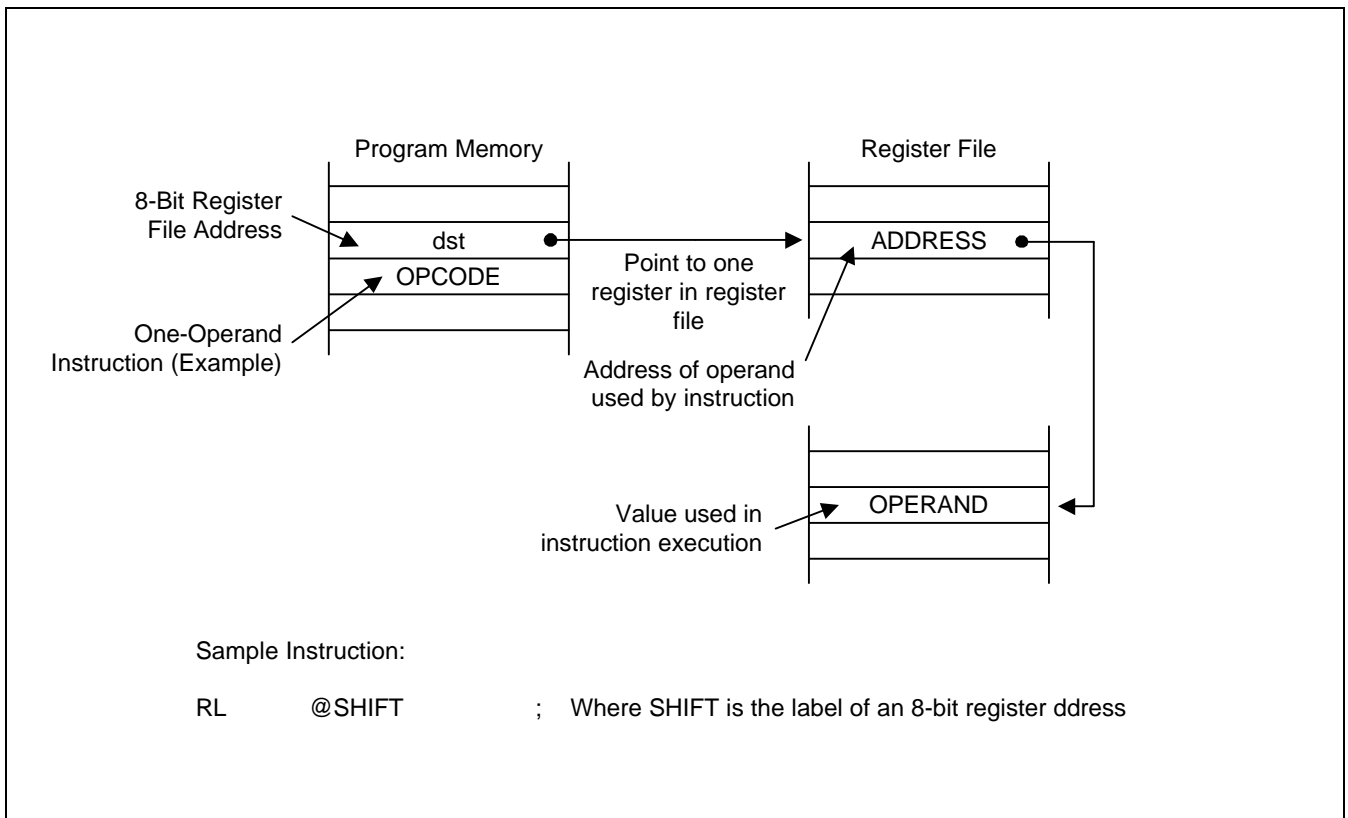


Figure 3-3. Indirect Register Addressing to Register File

INDIRECT REGISTER ADDRESSING MODE (Continued)

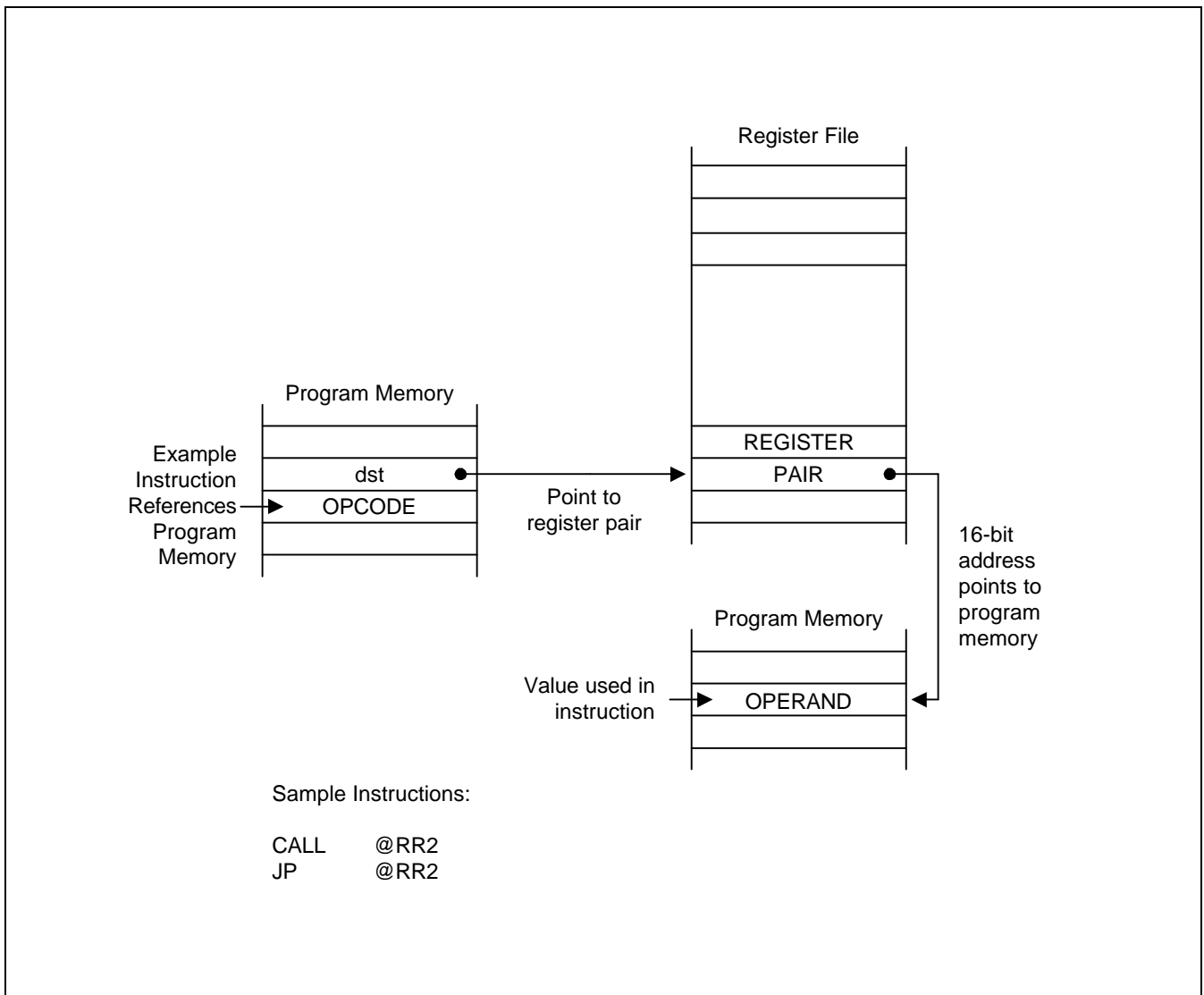


Figure 3-4. Indirect Register Addressing to Program Memory

INDIRECT REGISTER ADDRESSING MODE (Continued)

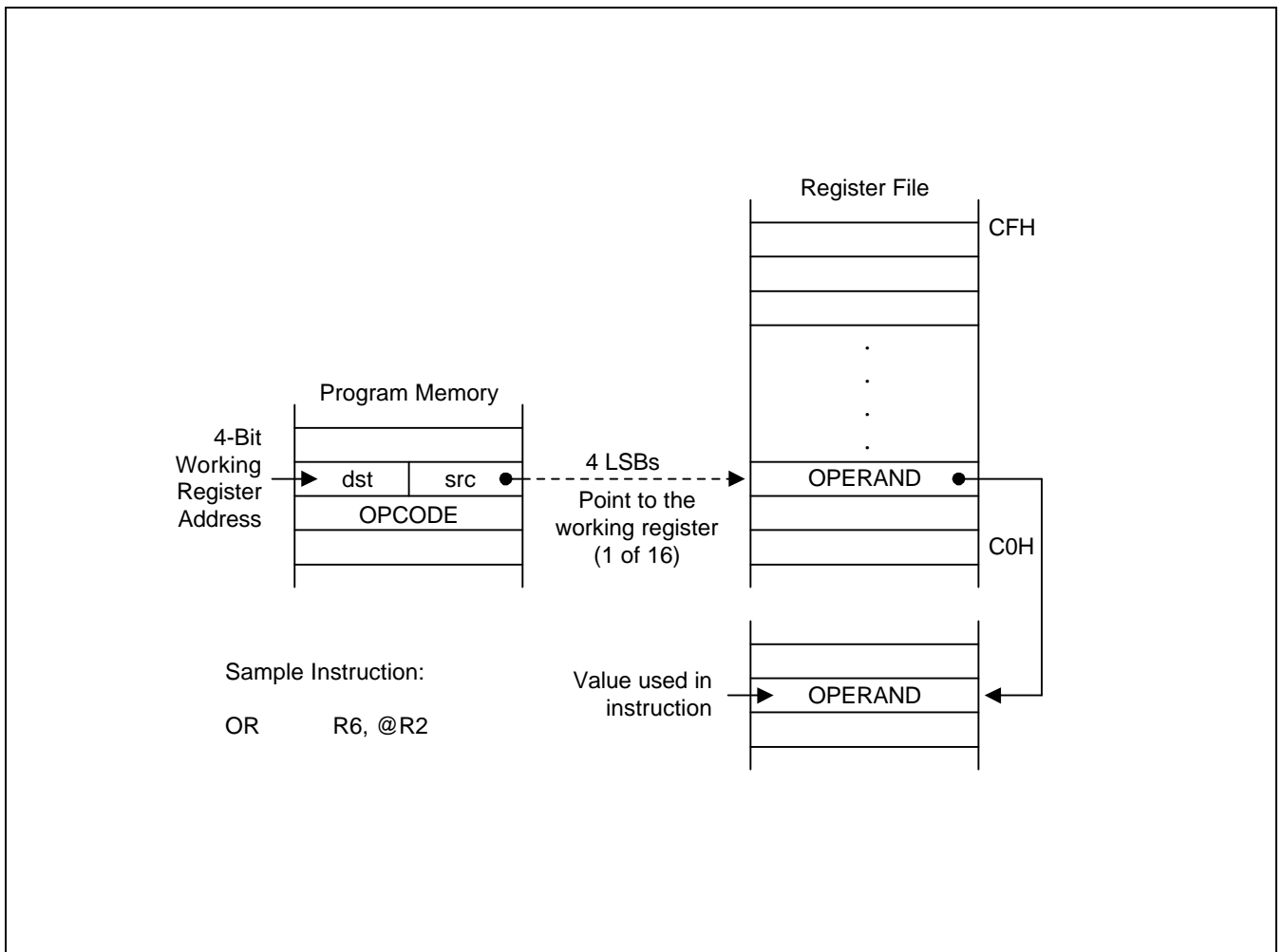


Figure 3-5. Indirect Working Register Addressing to Register File

INDIRECT REGISTER ADDRESSING MODE (Concluded)

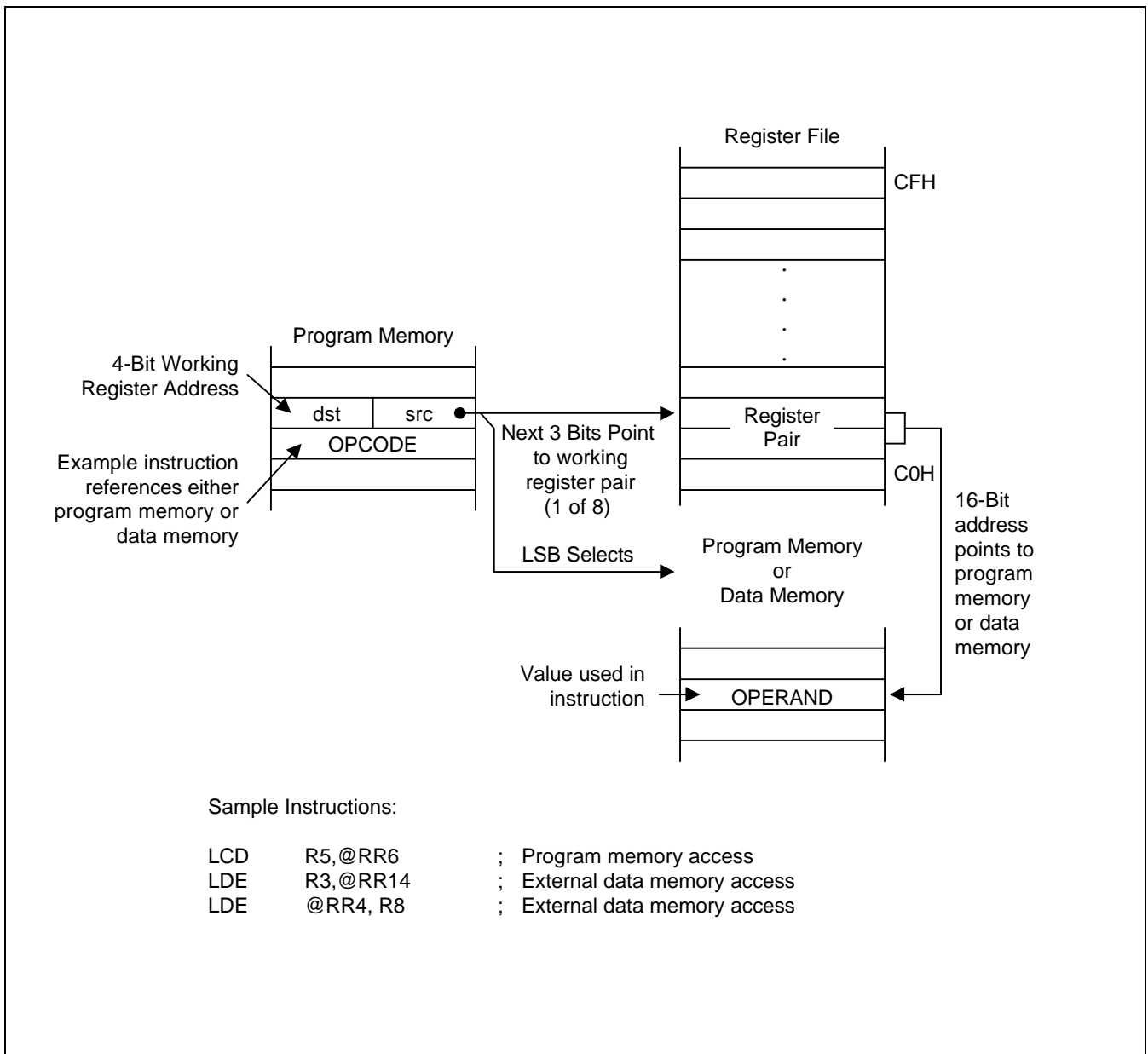


Figure 3-6. Indirect Working Register Addressing to Program or Data Memory

INDEXED ADDRESSING MODE (X)

Indexed (X) addressing mode adds an offset value to a base address during instruction execution in order to calculate the effective operand address (see Figure 3-7). You can use Indexed addressing mode to access locations in the internal register file or in external memory.

In short offset Indexed addressing mode, the 8-bit displacement is treated as a signed integer in the range - 128 to + 127. This applies to external memory accesses only (see Figure 3-8).

For register file addressing, an 8-bit base address provided by the instruction is added to an 8-bit offset contained in a working register. For external memory accesses, the base address is stored in the working register pair designated in the instruction. The 8-bit or 16-bit offset given in the instruction is then added to the base address (see Figure 3-9).

The only instruction that supports Indexed addressing mode for the internal register file is the Load instruction (LD). The LDC and LDE instructions support Indexed addressing mode for internal program memory, external program memory, and for external data memory, when implemented.

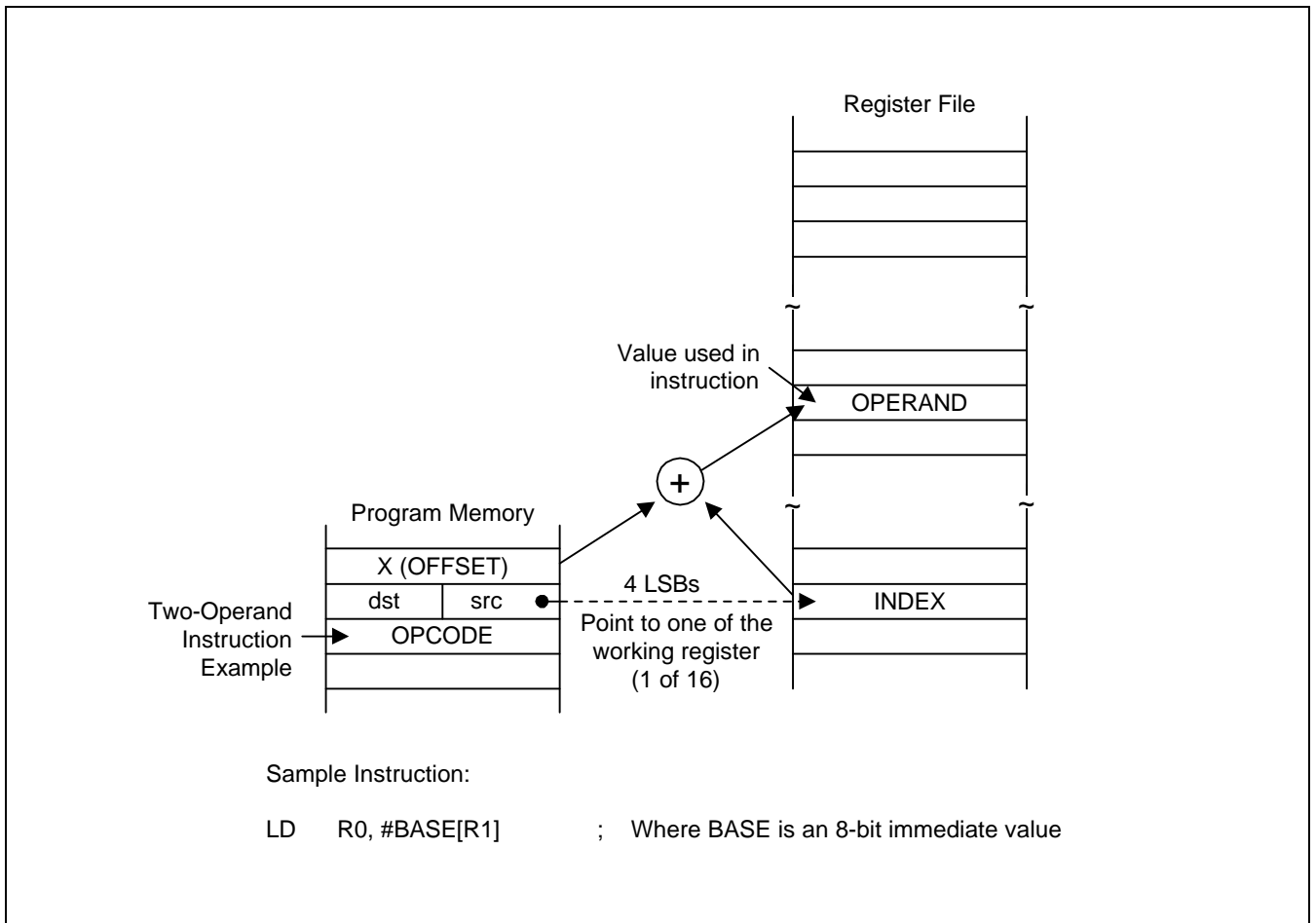


Figure 3-7. Indexed Addressing to Register File

INDEXED ADDRESSING MODE (Continued)

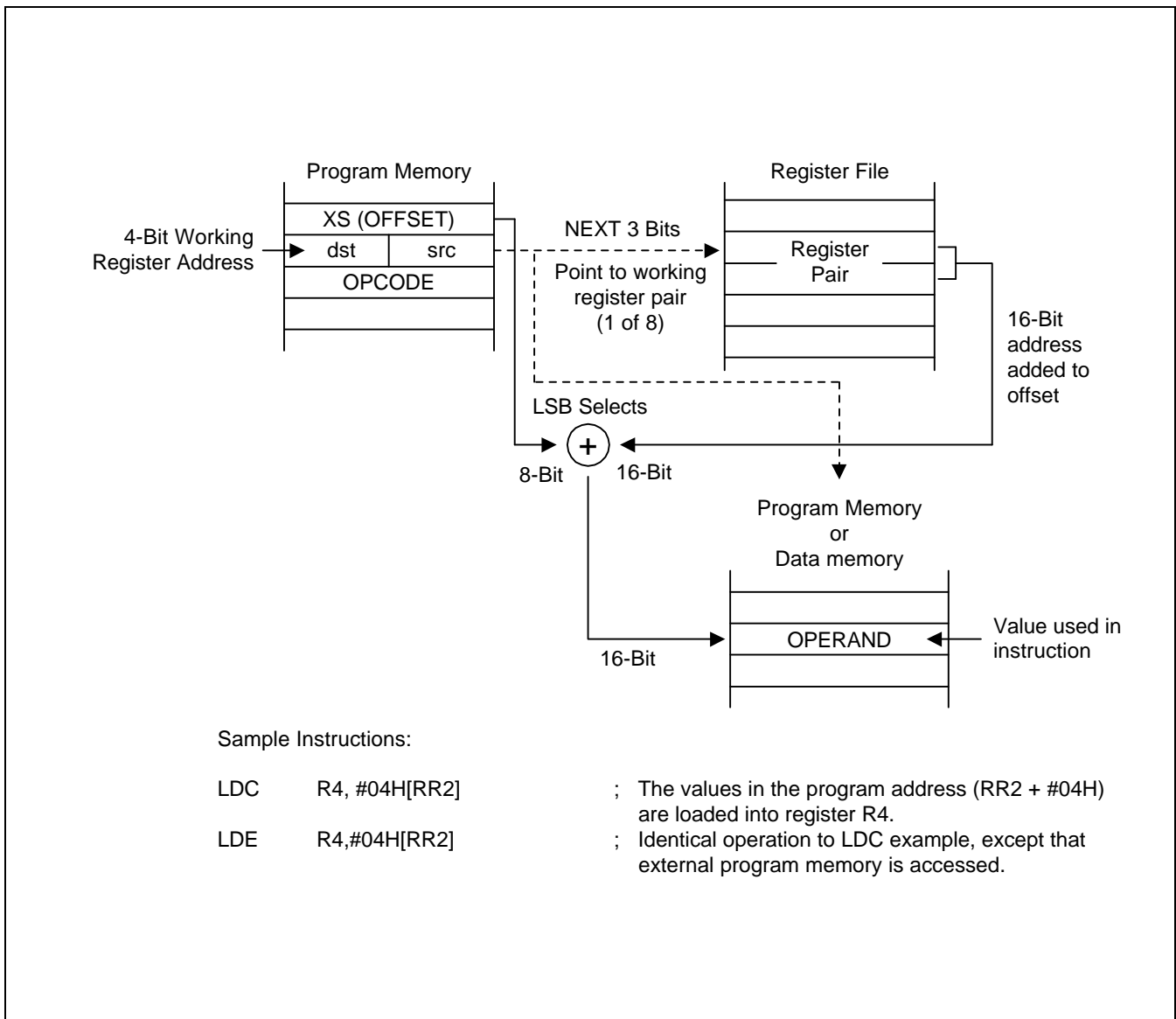


Figure 3-8. Indexed Addressing to Program or Data Memory with Short Offset

INDEXED ADDRESSING MODE (Concluded)

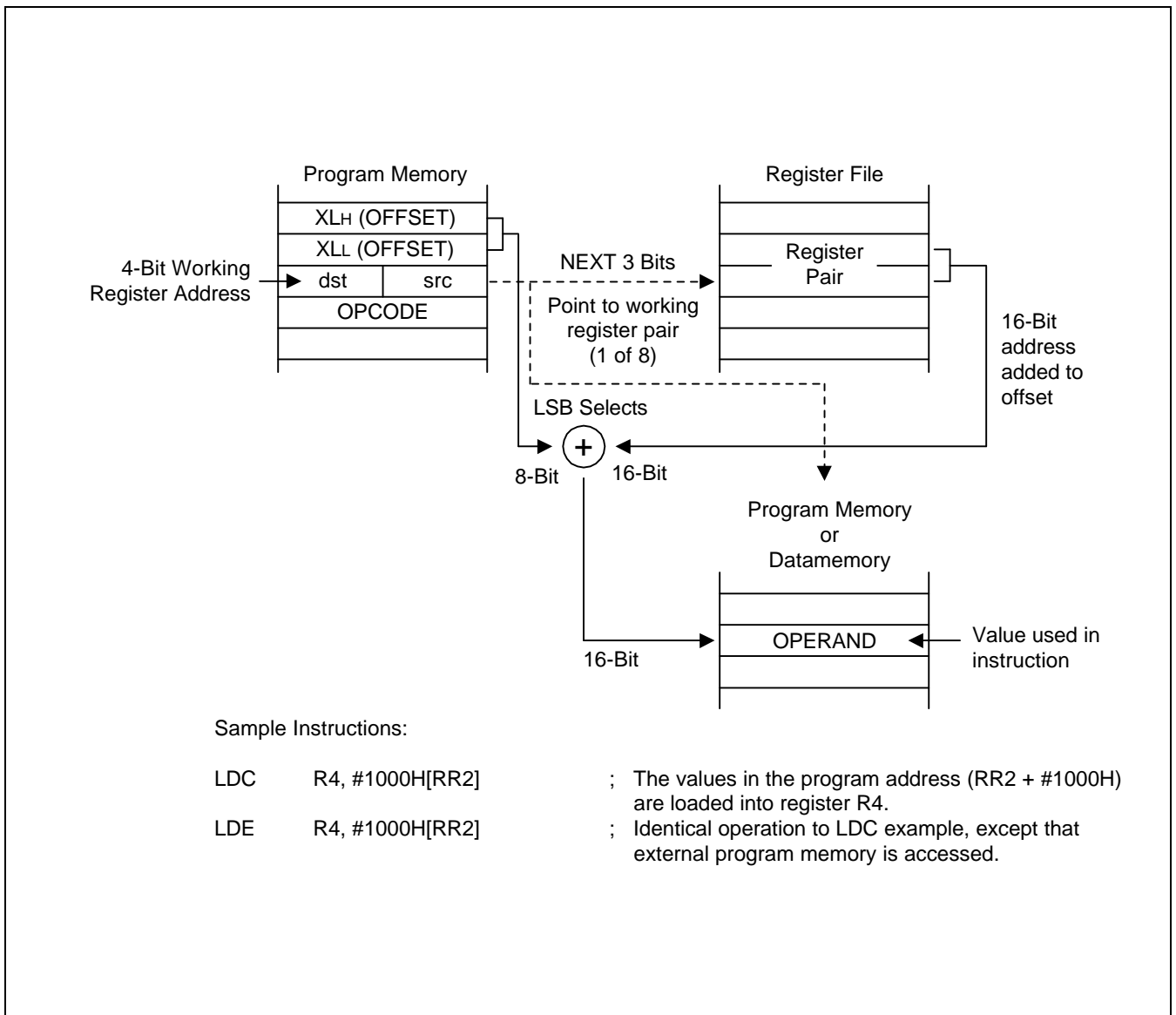


Figure 3-9. Indexed Addressing to Program or Data Memory with Long Offset

DIRECT ADDRESS MODE (DA)

In Direct Address (DA) mode, the instruction provides the operand's 16-bit memory address. Jump (JP) and Call (CALL) instructions use this addressing mode to specify the 16-bit destination address that is loaded into the PC whenever a JP or CALL instruction is executed.

The LDC and LDE instructions can use Direct Address mode to specify the source or destination address for Load operations to program memory (LDC) or to external data memory (LDE), if implemented.

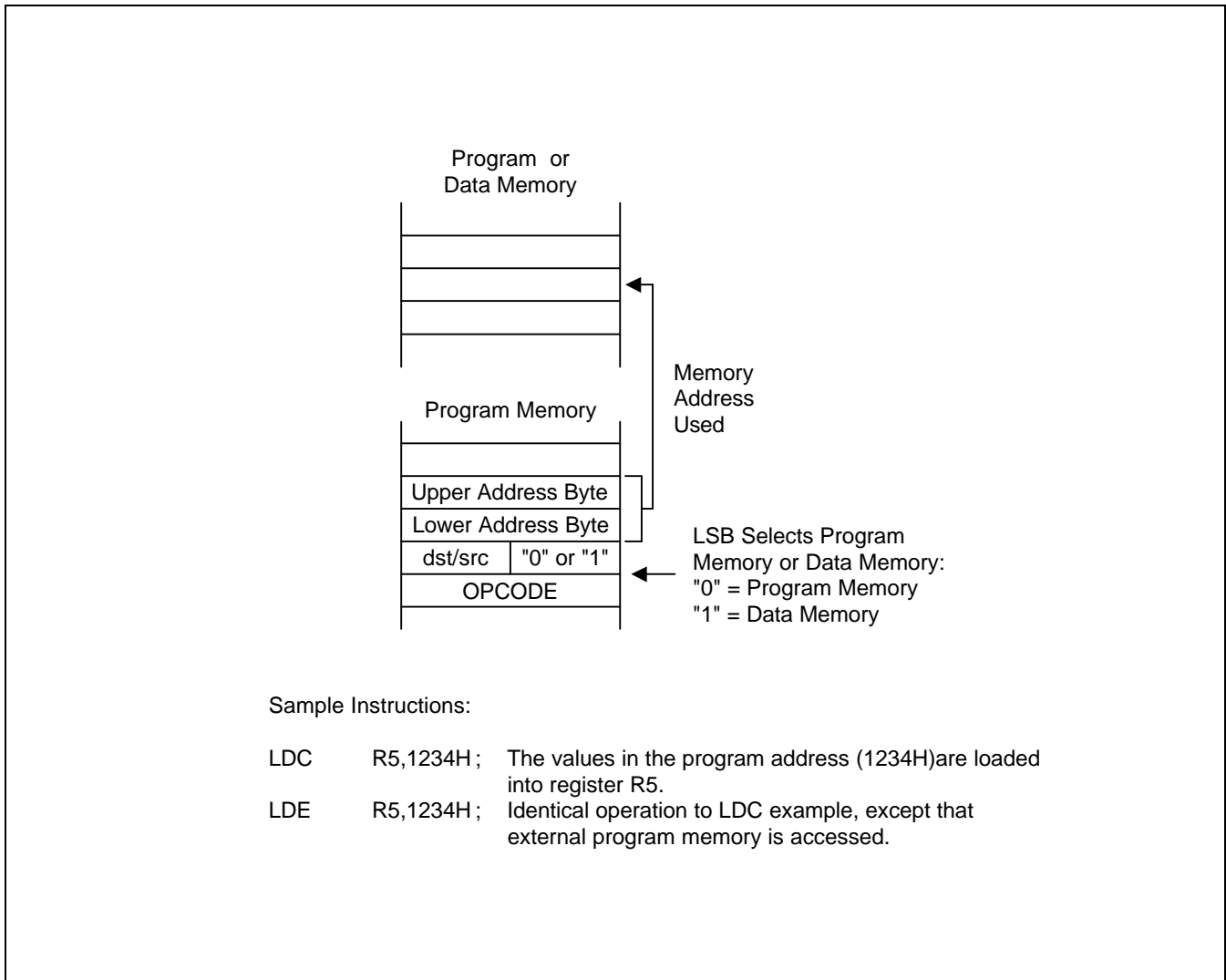


Figure 3-10. Direct Addressing for Load Instructions

DIRECT ADDRESS MODE (Continued)

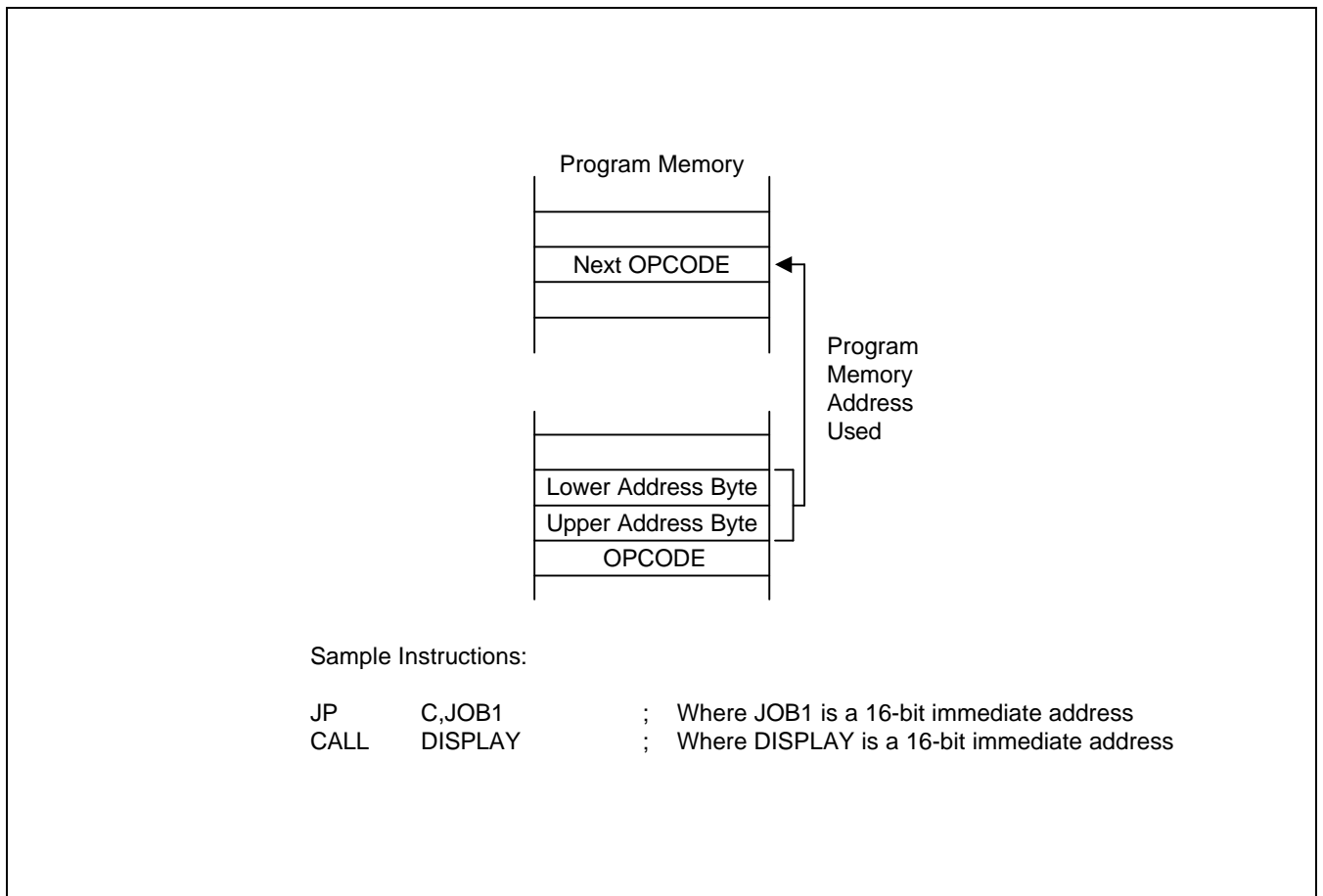


Figure 3-11. Direct Addressing for Call and Jump Instructions

RELATIVE ADDRESS MODE (RA)

In Relative Address (RA) mode, a two's-complement signed displacement between - 128 and + 127 is specified in the instruction. The displacement value is then added to the current PC value. The result is the address of the next instruction to be executed. Before this addition occurs, the PC contains the address of the instruction immediately following the current instruction.

The instructions that support RA addressing is JR.

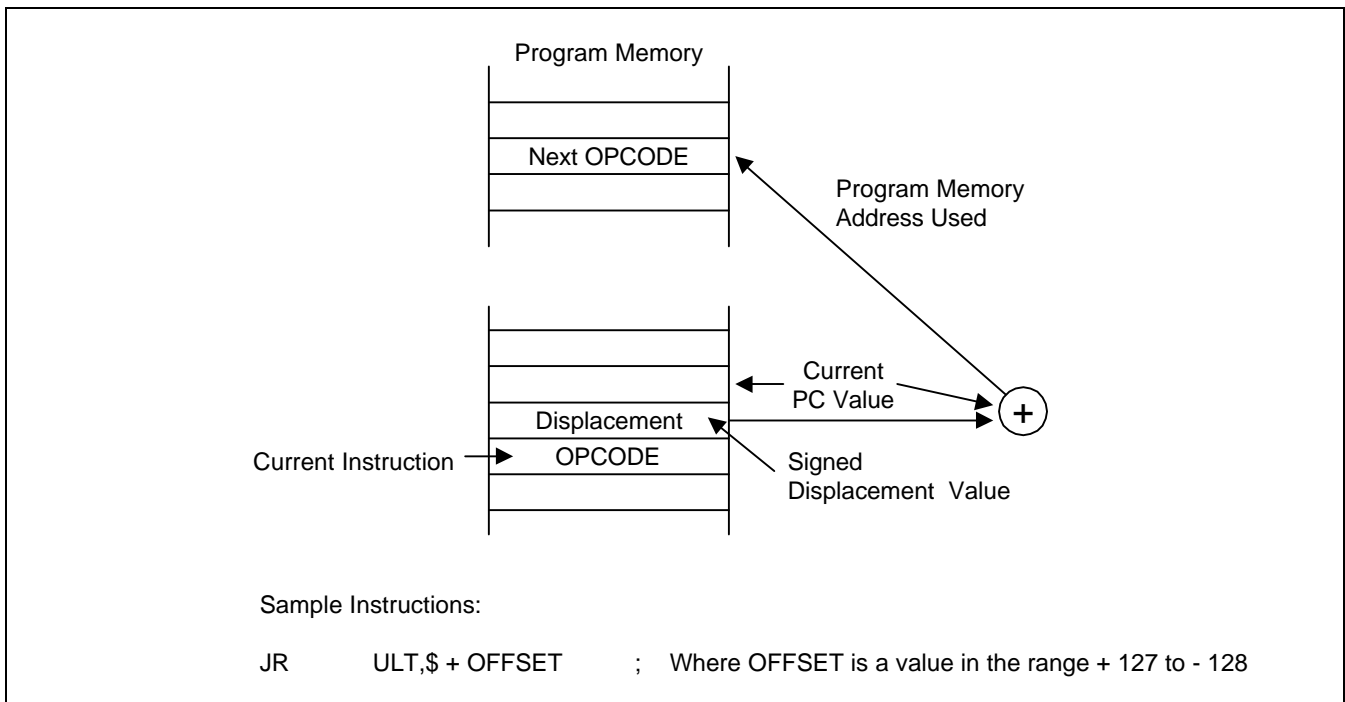


Figure 3-12. Relative Addressing

IMMEDIATE MODE (IM)

In Immediate (IM) addressing mode, the operand value used in the instruction is the value supplied in the operand field itself. Immediate addressing mode is useful for loading constant values into registers.

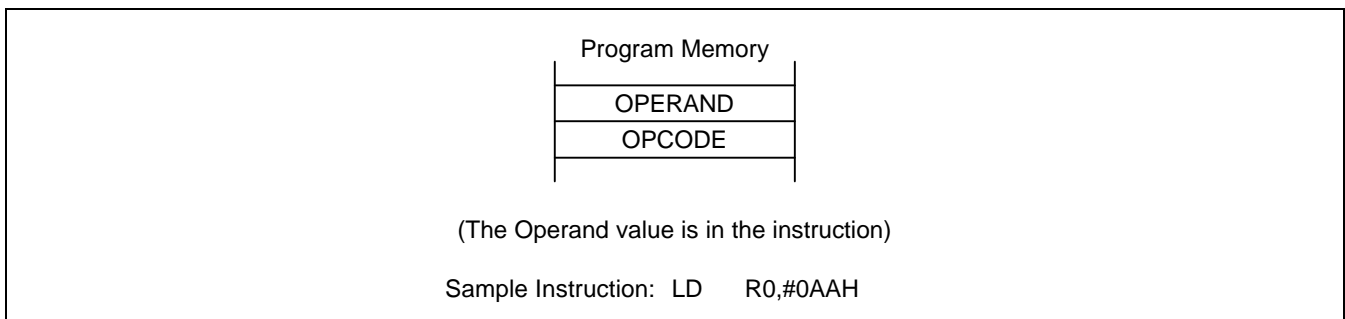


Figure 3-13. Immediate Addressing

4 CONTROL REGISTERS

OVERVIEW

In this section, detailed descriptions of the S3C9442/C9444/C9452/C9454 control registers are presented in an easy-to-read format. These descriptions will help familiarize you with the mapped locations in the register file. You can also use them as a quick-reference source when writing application programs.

System and peripheral registers are summarized in Table 4-1. Figure 4-1 illustrates the important features of the standard register description format.

Control register descriptions are arranged in alphabetical order according to register mnemonic. More information about control registers is presented in the context of the various peripheral hardware descriptions in Part II of this manual.

Table 4-1. System and Peripheral Control Registers

Register name	Mnemonic	Address & Location		RESET value (Bit)								
		Address	R/W	7	6	5	4	3	2	1	0	
Timer 0 counter register	T0CNT	D0H	R	0	0	0	0	0	0	0	0	0
Timer 0 data register	T0DATA	D1H	R/W	1	1	1	1	1	1	1	1	1
Timer 0 control register	T0CON	D2H	R/W	0	0	–	–	0	–	0	0	0
Location D3H is not mapped												
Clock control register	CLKCON	D4H	R/W	0	–	–	0	0	–	–	–	–
System flags register	FLAGS	D5H	R/W	x	x	x	x	–	–	–	–	–
Locations D6H–D8H are not mapped												
Stack pointer register	SP	D9H	R/W	x	x	x	x	x	x	x	x	x
Location DAH is not mapped												
MDS special register	MDSREG	DBH	R/W	0	0	0	0	0	0	0	0	0
Basic timer control register	BTCON	DCH	R/W	0	0	0	0	0	0	0	0	0
Basic timer counter	BTCNT	DDH	R	0	0	0	0	0	0	0	0	0
Test mode control register	FTSTCON	DEH	W	–	–	0	0	0	0	0	0	0
System mode register	SYM	DFH	R/W	–	–	–	–	–	0	0	0	0

NOTES:

- : Not mapped or not used, x: Undefined
- The factory test mode register, FTSTCON, is for factory use only. Its value should always be '00H' during the normal operation.

Table 4-1. System and Peripheral Control Registers (Continued)

Register Name	Mnemonic	Address Hex	R/W	Bit Values After RESET								
				7	6	5	4	3	2	1	0	
Port 0 data register	P0	E0H	R/W	0	0	0	0	0	0	0	0	0
Port 1 data register	P1	E1H	R/W	–	–	–	–	–	0	0	0	0
Port 2 data register	P2	E2H	R/W	–	0	0	0	0	0	0	0	0
Locations E3H–E5H are not mapped												
Port 0 control register (High byte)	P0CONH	E6H	R/W	0	0	0	0	0	0	0	0	0
Port 0 control register	P0CONL	E7H	R/W	0	0	0	0	0	0	0	0	0
Port 0 interrupt pending register	P0PND	E8H	R/W	–	–	–	–	0	0	0	0	0
Port 1 control register	P1CON	E9H	R/W	0	0	–	–	0	0	0	0	0
Port 2 control register (High byte)	P2CONH	EAH	R/W	–	0	0	0	0	0	0	0	0
Port 2 control register (Low byte)	P2CONL	EBH	R/W	0	0	0	0	0	0	0	0	0
Locations ECH–F1H are not mapped												
PWM data register	PWMDATA	F2H	R/W	0	0	0	0	0	0	0	0	0
PWM control register	PWMCON	F3H	R/W	0	0	–	0	0	0	0	0	0
STOP .control register	STOPCON	F4H	R/W	0	0	0	0	0	0	0	0	0
Locations F5H–F6H are not mapped												
A/D control register	ADCON	F7H	R/W	0	0	0	0	0	0	0	0	0
A/D converter data register (High)	ADDATAH	F8H	R	x	x	x	x	x	x	x	x	x
A/D converter data register (Low)	ADDATAL	F9H	R	0	0	0	0	0	0	0	x	x
Locations FAH–FFH are not mapped												

NOTE: – : Not mapped or not used, x: Undefined

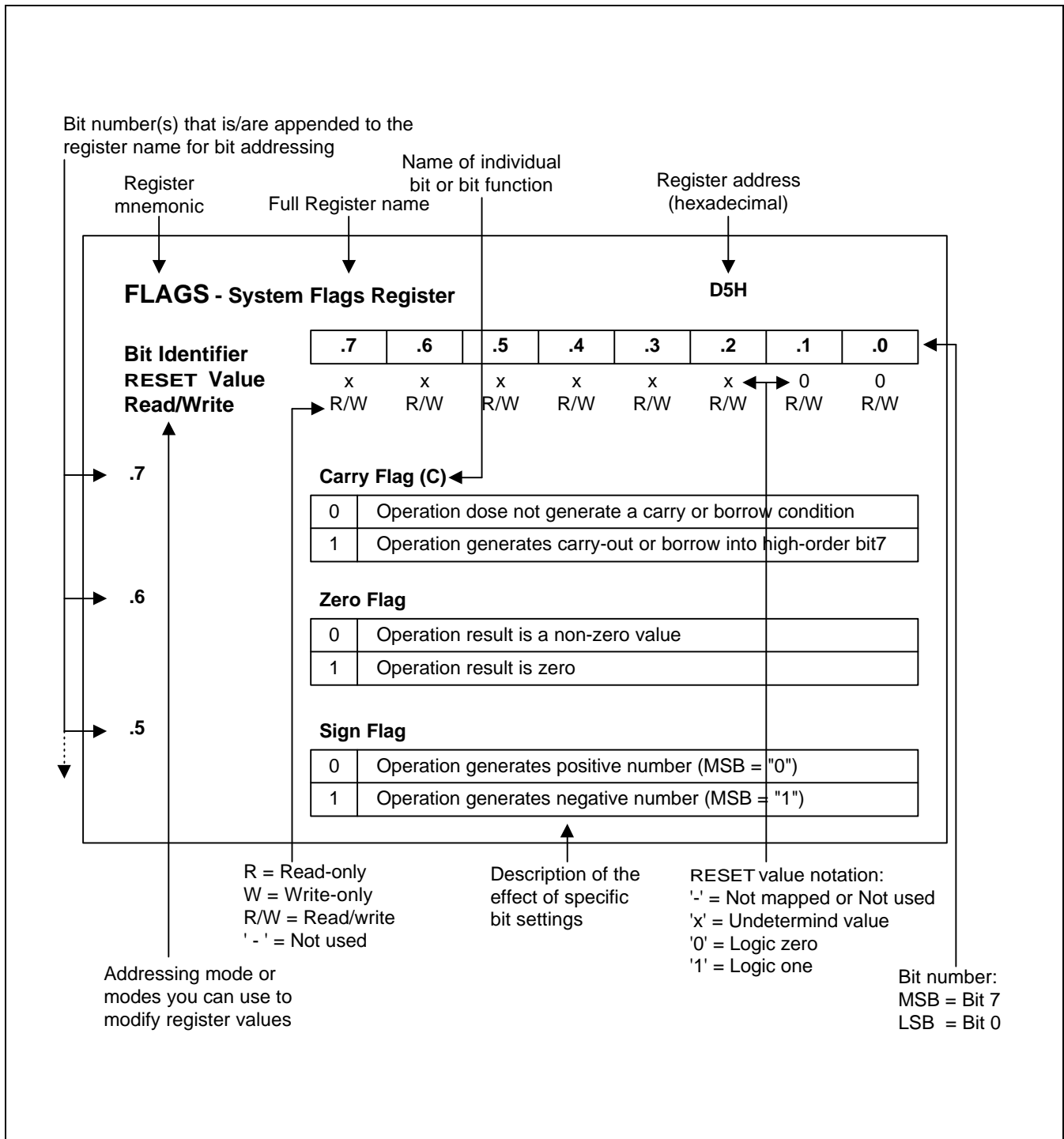


Figure 4-1. Register Description Format

ADCON — A/D Converter Control Register**F7H**

Bit Identifier	.7	.6	.5	.4	.3	.2	.1	.0
RESET Value	0	0	0	0	0	0	0	0
Read/Write	R/W	R/W	R/W	R/W	R/W	R/W	R/W	R/W

.7–.4**A/D Converter Input Pin Selection Bits**

0	0	0	0	ADC0 (P0.0)
0	0	0	1	ADC1 (P0.1)
0	0	1	0	ADC2 (P0.2)
0	0	1	1	ADC3 (P0.3)/ In S3C9444, connected with GND internally
0	1	0	0	ADC4 (P0.4)/ In S3C9444, connected with GND internally
0	1	0	1	ADC5 (P0.5)/ In S3C9444, connected with GND internally
0	1	1	0	ADC6 (P0.6)/ In S3C9444, connected with GND internally
0	1	1	1	ADC7 (P0.7)/ In S3C9444, connected with GND internally
1	0	0	0	ADC8 (P2.6)/ In S3C9444, connected with GND internally
1	0	0	1	Connected with GND internally
1	0	1	0	Connected with GND internally
1	0	1	1	Connected with GND internally
1	1	0	0	Connected with GND internally
1	1	0	1	Connected with GND internally
1	1	1	0	Connected with GND internally
1	1	1	1	Connected with GND internally

.3**End-of-Conversion Status Bit**

0	A/D conversion is in progress
1	A/D conversion complete

.2–.1**Clock Source Selection Bit** (note)

0	0	$f_{OSC}/16$ ($f_{OSC} \leq 10$ MHz)
0	1	$f_{OSC}/8$ ($f_{OSC} \leq 10$ MHz)
1	0	$f_{OSC}/4$ ($f_{OSC} \leq 10$ MHz)
1	1	$f_{OSC}/1$ ($f_{OSC} \leq 2.5$ MHz)

.0**Conversion Start Bit**

0	No meaning
1	A/D conversion start

NOTE: Maximum ADC clock input = 4 MHz.

BTCON — Basic Timer Control Register

DCH

Bit Identifier	.7	.6	.5	.4	.3	.2	.1	.0
RESET Value	0	0	0	0	0	0	0	0
Read/Write	R/W	R/W	R/W	R/W	R/W	R/W	R/W	R/W

.7–.4**Watchdog Timer Function Enable Bit**

1	0	1	0	Disable watchdog timer function
Others				Enable watchdog timer function

.3–.2**Basic Timer Input Clock Selection Code**

0	0	$f_{OSC}/4096$
0	1	$f_{OSC}/1024$
1	0	$f_{OSC}/128$
1	1	Invalid setting

.1**Basic Timer 8-Bit Counter Clear Bit**

0	No effect
1	Clear the basic timer counter value

.0**Basic Timer Divider Clear Bit**

0	No effect
1	Clear both dividers

NOTE: When you write a "1" to BTCON.0 (or BTCON.1), the basic timer counter (or basic timer divider) is cleared. The bit is then cleared automatically to "0".

CLKCON — Clock Control Register

D4H

Bit Identifier	.7	.6	.5	.4	.3	.2	.1	.0
RESET Value	0	–	–	0	0	–	–	–
Read/Write	R/W	–	–	R/W	R/W	–	–	–

.7**Oscillator IRQ Wake-up Function Enable Bit**

0	Enable IRQ for main system oscillator wake-up function
1	Disable IRQ for main system oscillator wake-up function

.6–5

Not used for S3C9442/C9444/C9452/C9454

.4–3**Divided by Selection Bits for CPU Clock frequency**

0	0	Divide by 16 ($f_{OSC}/16$)
0	1	Divide by 8 ($f_{OSC}/8$)
1	0	Divide by 2 ($f_{OSC}/2$)
1	1	Non-divided clock (f_{OSC})

.2–0

Not used for S3C9442/C9444/C9452/C9454

FLAGS — System Flags Register

D5H

Bit Identifier	.7	.6	.5	.4	.3	.2	.1	.0
RESET Value	x	x	x	x	–	–	–	–
Read/Write	R/W	R/W	R/W	R/W	–	–	–	–

.7

Carry Flag (C)

0	Operation does not generate a carry or borrow condition
1	Operation generates a carry-out or borrow into high-order bit 7

.6

Zero Flag (Z)

0	Operation result is a non-zero value
1	Operation result is zero

.5

Sign Flag (S)

0	Operation generates a positive number (MSB = "0")
1	Operation generates a negative number (MSB = "1")

.4

Overflow Flag (V)

0	Operation result is $\leq +127$ or ≥ -128
1	Operation result is $> +127$ or < -128

.3–.0

Not used for S3C9442/C9444/C9452/C9454

P0CONH — Port 0 Control Register (High Byte)**E6H**

Bit Identifier	.7	.6	.5	.4	.3	.2	.1	.0
RESET Value	0	0	0	0	0	0	0	0
Read/Write	R/W	R/W	R/W	R/W	R/W	R/W	R/W	R/W

.7–6**Port 0, P0.7/INT7 Configuration Bits**

0	0	Schmitt trigger input; pull-up enable
0	1	Schmitt trigger input
1	0	Push-pull output
1	1	A/D converter input (ADC7); Schmitt trigger input off

.5–4**Port 0, P0.6/ADC6/PWM Configuration Bits**

0	0	Schmitt trigger input; pull-up enable
0	1	Alternative function (PWM output)
1	0	Push-pull output
1	1	A/D converter input (ADC6); Schmitt trigger input off

.3–2**Port 0, P0.5/ADC5 Configuration Bits**

0	0	Schmitt trigger input; pull-up enable
0	1	Schmitt trigger input
1	0	Push-pull output
1	1	A/D converter input (ADC5); Schmitt trigger input off

.1–0**Port 0, P0.4/ADC4 Configuration Bits**

0	0	Schmitt trigger input; pull-up enable
0	1	Schmitt trigger input
1	0	Push-pull output
1	1	A/D converter input (ADC4); Schmitt trigger input off

P0CONL — Port 0 Control Register (Low Byte)**E7H**

Bit Identifier	.7	.6	.5	.4	.3	.2	.1	.0
RESET Value	0	0	0	0	0	0	0	0
Read/Write	R/W	R/W	R/W	R/W	R/W	R/W	R/W	R/W

.7–.6**Port 0, P0.3/INT3 Configuration Bits**

0	0	Schmitt trigger input
0	1	Schmitt trigger input; pull-up enable
1	0	Push-pull output
1	1	A/D converter input (ADC3); Schmitt trigger input off

.5–.4**Port 0, P0.2/ADC2 Configuration Bits**

0	0	Schmitt trigger input
0	1	Schmitt trigger input; pull-up enable
1	0	Push-pull output
1	1	A/D converter input (ADC2); Schmitt trigger input off

.3–.2**Port 0, P0.1/ADC1/INT1 Configuration Bits**

0	0	Schmitt trigger input/falling edge interrupt input
0	1	Schmitt trigger input; pull-up enable/falling edge interrupt input
1	0	Push-pull output
1	1	A/D converter input (ADC1); Schmitt trigger input off

.1–.0**Port 0, P0.0/ADC0/INT0 Configuration Bits**

0	0	Schmitt trigger input/falling edge interrupt input
0	1	Schmitt trigger input; pull-up enable/falling edge interrupt input
1	0	Push-pull output
1	1	A/D converter input (ADC0); Schmitt trigger input off

POPND — Port 0 Interrupt Pending Register**E8H**

Bit Identifier	.7	.6	.5	.4	.3	.2	.1	.0
RESET Value	–	–	–	–	0	0	0	0
Read/Write	–	–	–	–	R/W	R/W	R/W	R/W

.7–.4

Not used for the S3C9442/C9444/C9452/C9454
--

.3 **Port 0.1/ADC1/INT1 Interrupt Enable Bit**

0	INT1 falling edge interrupt disable
1	INT1 falling edge interrupt enable

.2 **Port 0.1/ADC1/INT1 Interrupt Pending Bit**

0	No interrupt pending (when read)
0	<i>Pending bit clear (when write)</i>
1	Interrupt is pending (when read)
1	No effect (when write)

.1 **Port 0.0/ADC0/INT0 Interrupt Enable Bit**

0	INT0 falling edge interrupt disable
1	INT0 falling edge interrupt enable

.0 **Port 0.0/ADC0/INT0 Interrupt Pending Bit**

0	No interrupt pending (when read)
0	<i>Pending bit clear (when write)</i>
1	Interrupt pending (when read)
1	No effect (when write)

P1CON — Port 1 Control Register

E9H

Bit Identifier	.7	.6	.5	.4	.3	.2	.1	.0
RESET Value	0	0	–	–	0	0	0	0
Read/Write	R/W	R/W	–	–	R/W	R/W	R/W	R/W

.7**Part 1.1 N-channel open-drain Enable Bit**

0	Configure P1.1 as a push-pull output
1	Configure P1.1 as a n-channel open-drain output

.6**Port 1.0 N-channel open-drain Enable Bit**

0	Configure P1.0 as a push-pull output
1	Configure P1.0 as a n-channel open-drain output

.5–.4

Not used for S3C9442/C9444/C9452/C9454

.3–.2**Port 1, P1.1 Interrupt Pending Bits**

0	0	Schmitt trigger input;
0	1	Schmitt trigger input; pull-up enable
1	0	Output
1	1	Schmitt trigger input; pull-down enable

.1–.0**Port 0, P1.0 Configuration Bits**

0	0	Schmitt trigger input;
0	1	Schmitt trigger input; pull-up enable
1	0	Output
1	1	Schmitt trigger input; pull-down enable

NOTE: When you use external oscillator, P1.0, P1.1 must be set to output port to prevent current consumption.

P2CONH — Port 2 Control Register (High Byte)

EAH

Bit Identifier	.7	.6	.5	.4	.3	.2	.1	.0
RESET Value	–	0	0	0	0	0	0	0
Read/Write	–	R/W	R/W	R/W	R/W	R/W	R/W	R/W

.7

Not used for the S3C9442/C9444/C9452/C9454

.6–.4

Port 2, P2.6/ADC8/CLO Configuration Bits

0	0	0	Schmitt trigger input; pull-up enable
0	0	1	Schmitt trigger input
0	1	x	ADC input
1	0	0	Push-pull output
1	0	1	Open-drain output; pull-up enable
1	1	0	Open-drain output
1	1	1	Alternative function; CLO output

.3–.2

Port 2, 2.5 Configuration Bits

0	0	Schmitt trigger input; pull-up enable
0	1	Schmitt trigger input
1	0	Push-pull output
1	1	Open-drain output

.1–.0

Port 2, 2.4 Configuration Bits

0	0	Schmitt trigger input; pull-up enable
0	1	Schmitt trigger input
1	0	Push-pull output
1	1	Open-drain output

NOTE: When noise problem is important issue, you had better not use CLO output.

P2CONL — Port 2 Control Register (Low Byte)**EBH**

Bit Identifier	.7	.6	.5	.4	.3	.2	.1	.0
RESET Value	0	0	0	0	0	0	0	0
Read/Write	R/W	R/W	R/W	R/W	R/W	R/W	R/W	R/W

.7–.6**Part 2, P2.3 Configuration Bits**

0	0	Schmitt trigger input; pull-up enable
0	1	Schmitt trigger input
1	0	Push-pull output
1	1	Open-drain output

.5–.4**Port 2, P2.2 Configuration Bits**

0	0	Schmitt trigger input; pull-up enable
0	1	Schmitt trigger input
1	0	Push-pull output
1	1	Open-drain output

.3–.2**Port 2, P2.1 Configuration Bits**

0	0	Schmitt trigger input; pull-up enable
0	1	Schmitt trigger input
1	0	Push-pull output
1	1	Open-drain output

.1–.0**Port 2, P2.0 Configuration Bits**

0	0	Schmitt trigger input; pull-up enable
0	1	Schmitt trigger input
1	0	Push-pull output
1	1	T0 match output

PWMCON — PWM Control Register**E3H**

Bit Identifier	.7	.6	.5	.4	.3	.2	.1	.0
RESET Value	0	0	–	0	0	0	0	0
Read/Write	R/W	R/W	–	R/W	R/W	R/W	R/W	R/W

.7–.6**PWM Input Clock Selection Bits**

0	0	$f_{OSC}/64$
0	1	$f_{OSC}/8$
1	0	$f_{OSC}/2$
1	1	$f_{OSC}/1$

.5

Not used for S3C9442/C9444/C9452/C9454

.4**PWMDATA Reload Interval Selection Bit**

0	Reload from 8-bit up counter overflow
1	Reload from 6-bit up counter overflow

.3**PWM Counter Clear Bit**

0	No effect
1	Clear the PWM counter (when write)

.2**PWM Counter Enable Bit**

0	Stop counter
1	Start (Resume countering)

.1**PWM Overflow Interrupt Enable Bit (8-Bit Overflow)**

0	Disable interrupt
1	Enable interrupt

.0**PWM Overflow Interrupt Pending Bit**

0	No interrupt pending (when read)
0	Clear pending bit (when write)
1	Interrupt is pending (when read)
1	No effect (when write)

NOTE: PWMCON.3 is not auto-cleared. You must pay attention when clear pending bit. (refer to page 11-8).

STOPCON — STOP Mode Control Register

E4H

Bit Identifier	.7	.6	.5	.4	.3	.2	.1	.0
RESET Value	0	0	0	0	0	0	0	0
Read/Write	R/W	R/W	R/W	R/W	R/W	R/W	R/W	R/W

.7–.0

Watchdog Timer Function Enable Bit

10100101	Enable STOP instruction
Other value	Disable STOP instruction

NOTE: When STOPCON register is not #0A5H value, if you use STOP instruction, PC is changed to reset address.

SYM — System Mode Register

DFH

Bit Identifier	.7	.6	.5	.4	.3	.2	.1	.0
RESET Value	–	–	–	–	–	0	0	0
Read/Write	–	–	–	–	–	R/W	R/W	R/W

.7–.3

Not used for S3C9442/C9444/C9452/C9454

.2

Global Interrupt Enable Bit

0	Disable all interrupts
1	Enable all interrupt

.1–.0

Page Select Bits

0	0	Page 0
0	1	Page 1 (Not used for S3C9442/C9444/C9452/C9454)
1	0	Page 2 (Not used for S3C9442/C9444/C9452/C9454)
1	1	Page 3 (Not used for S3C9442/C9444/C9452/C9454)

T0CON — TIMER 0 Control Register**F4H**

Bit Identifier	.7	.6	.5	.4	.3	.2	.1	.0
RESET Value	0	0	–	–	0	–	0	0
Read/Write	R/W	R/W	–	–	R/W	–	R/W	R/W

.7–.6**Timer 0 Input Clock Selection Bits**

0	0	$f_{OSC}/256$
0	1	$f_{OSC}/64$
1	0	$f_{OSC}/8$
1	1	$f_{OSC}/1$

.5–.4

Not used for the S3C9442/C9444/C9452/C9454

.3**Timer 0 Counter Clear Bit**

0	No effect
1	Clear the timer 0 counter (when write)

.2

Not used for the S3C9442/C9444/C9452/C9454

.1**Timer 0 Interrupt Enable Bit**

0	Disable interrupt
1	Enable interrupt

.0**Timer 0 Interrupt Pending Bit (Capture or match interrupt)**

0	No interrupt pending (when read)
0	Clear pending bit (when write)
1	Interrupt is pending (when read)
1	No effect (when write)

NOTE: T0CON.3 is not auto-cleared. You must pay attention when clear pending bit. (refer to page 10-12)

5 INTERRUPT STRUCTURE

OVERVIEW

The SAM88RCRI interrupt structure has two basic components: a vector, and sources. The number of interrupt sources can be serviced through an interrupt vector which is assigned in ROM address 0000H.

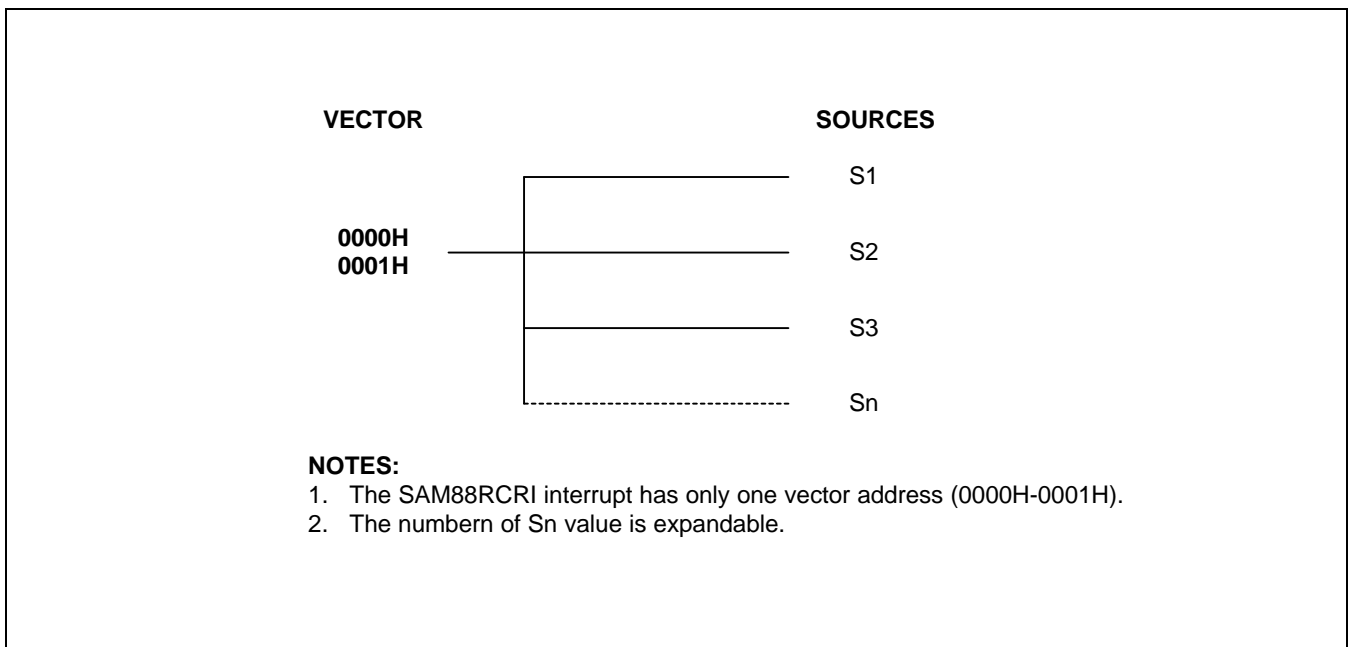


Figure 5-1. S3F9-Series Interrupt Type

INTERRUPT PROCESSING CONTROL POINTS

Interrupt processing can be controlled in two ways: either globally, or by specific interrupt level and source. The system-level control points in the interrupt structure are therefore:

- Global interrupt enable and disable (by EI and DI instructions)
- Interrupt source enable and disable settings in the corresponding peripheral control register(s)

ENABLE/DISABLE INTERRUPT INSTRUCTIONS (EI, DI)

The system mode register, SYM (DFH), is used to enable and disable interrupt processing.

SYM.2 is the enable and disable bit for global interrupt processing respectively, by modifying SYM.2. An Enable Interrupt (EI) instruction must be included in the initialization routine that follows a reset operation in order to enable interrupt processing. Although you can manipulate SYM.2 directly to enable and disable interrupts during normal operation, we recommend that you use the EI and DI instructions for this purpose.

INTERRUPT PENDING FUNCTION TYPES

When the interrupt service routine has executed, the application program's service routine must clear the appropriate pending bit before the return from interrupt subroutine (IRET) occurs.

INTERRUPT PRIORITY

Because there is not a interrupt priority register in SAM88RCRI, the order of service is determined by a sequence of source which is executed in interrupt service routine.

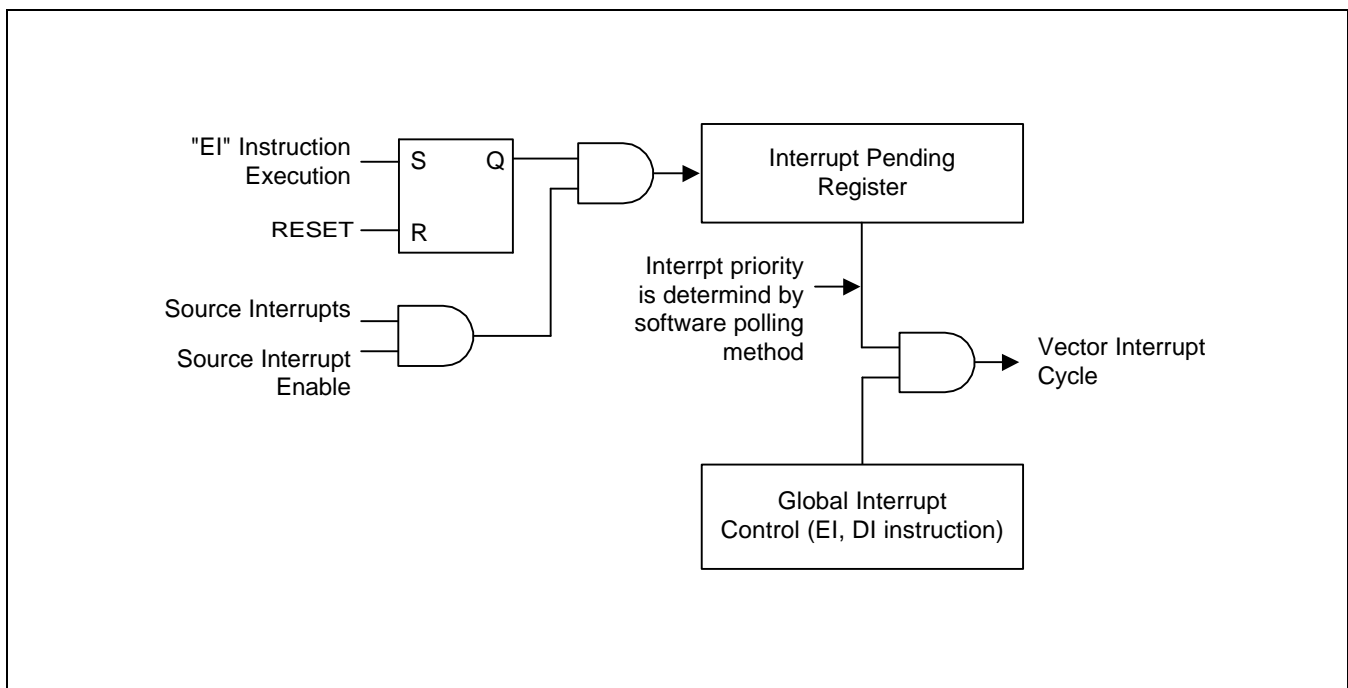


Figure 5-2. Interrupt Function Diagram

INTERRUPT SOURCE SERVICE SEQUENCE

The interrupt request polling and servicing sequence is as follows:

1. A source generates an interrupt request by setting the interrupt request pending bit to "1".
2. The CPU generates an interrupt acknowledge signal.
3. The service routine starts and the source's pending flag is cleared to "0" by software.
4. Interrupt priority must be determined by software polling method.

INTERRUPT SERVICE ROUTINES

Before an interrupt request can be serviced, the following conditions must be met:

- Interrupt processing must be enabled (EI, SYM.2 = "1")
- Interrupt must be enabled at the interrupt's source (peripheral control register)

If all of the above conditions are met, the interrupt request is acknowledged at the end of the instruction cycle. The CPU then initiates an interrupt machine cycle that completes the following processing sequence:

1. Reset (clear to "0") the global interrupt enable bit in the SYM register (DI, SYM.2 = "0") to disable all subsequent interrupts.
2. Save the program counter and status flags to stack.
3. Branch to the interrupt vector to fetch the service routine's address.
4. Pass control to the interrupt service routine.

When the interrupt service routine is completed, an Interrupt Return instruction (IRET) occurs. The IRET restores the PC and status flags and sets SYM.2 to "1" (EI), allowing the CPU to process the next interrupt request.

GENERATING INTERRUPT VECTOR ADDRESSES

The interrupt vector area in the ROM contains the address of the interrupt service routine. Vectored interrupt processing follows this sequence:

1. Push the program counter's low-byte value to stack.
2. Push the program counter's high-byte value to stack.
3. Push the FLAGS register values to stack.
4. Fetch the service routine's high-byte address from the vector address 0000H.
5. Fetch the service routine's low-byte address from the vector address 0001H.
6. Branch to the service routine specified by the 16-bit vector address.

S3C9442/C9444/C9452/C9454 INTERRUPT STRUCTURE

The S3C9442/C9444/C9452/C9454 microcontroller has four peripheral interrupt sources:

- PWM overflow
- Timer 0 match
- P0.0 external interrupt
- P0.1 external interrupt

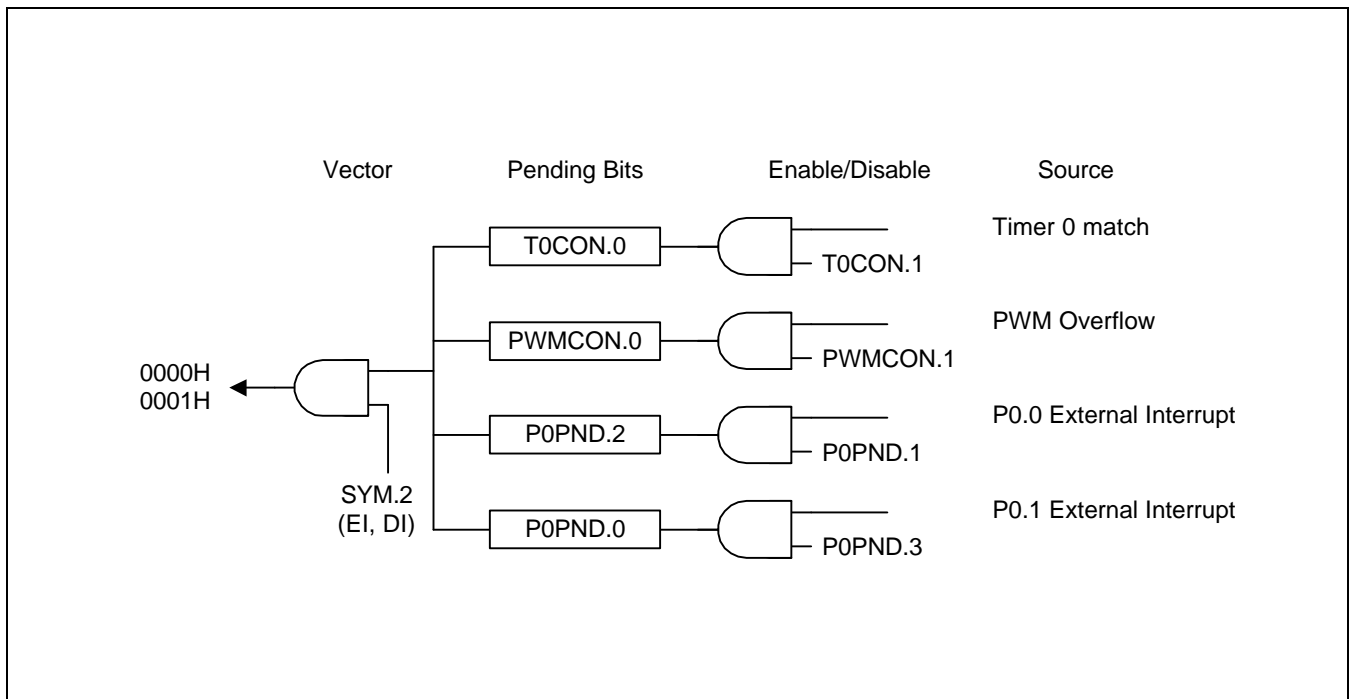


Figure 5-3. S3C9442/C9444/C9452/C9454 Interrupt Structure

7

CLOCK CIRCUIT

OVERVIEW

By smart option (3FH.1–0 in ROM), user can select internal RC oscillator or external oscillator. In using internal oscillator, X_{IN} (P1.0), X_{OUT} (P1.1) can be used by normal I/O pins. An internal RC oscillator source provides a typical 3.2 MHz or 0.5 MHz (in V_{DD} = 5 V) depending on smart option.

An external RC oscillation source provides a typical 4 MHz clock for KS86C4502/C4504. An internal capacitor supports the RC oscillator circuit. An external crystal or ceramic oscillation source provides a maximum 10 MHz clock. The X_{IN} and X_{OUT} pins connect the oscillation source to the on-chip clock circuit. Simplified external RC oscillator and crystal/ceramic oscillator circuits are shown in Figures 7-1 and 7-2. When you use external oscillator, P1.0, P1.1 must be set to output port to prevent current consumption

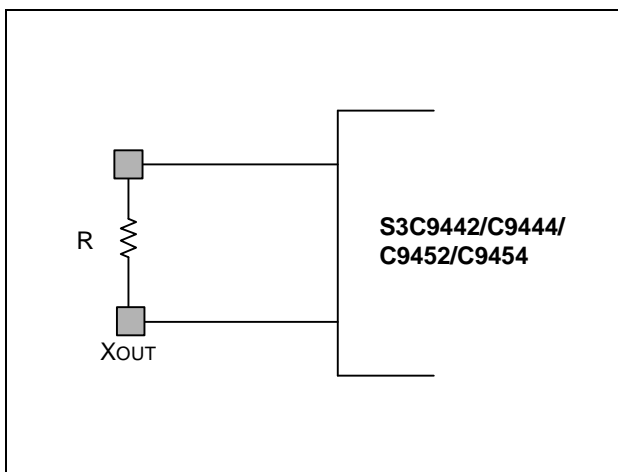


Figure 7-1. Main Oscillator Circuit
(RC Oscillator with Internal Capacitor)

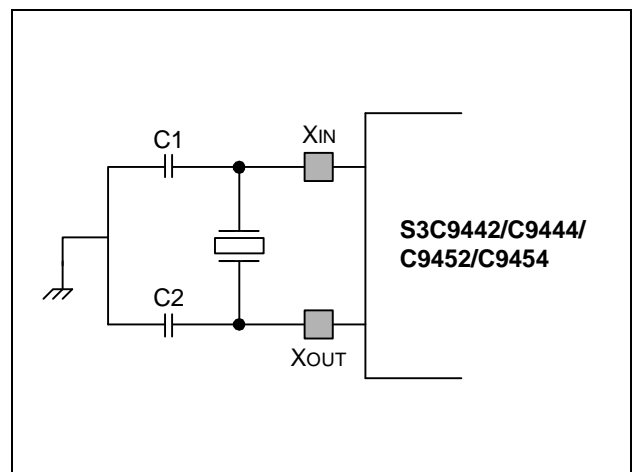


Figure 7-2. Main Oscillator Circuit
(Crystal/Ceramic Oscillator)

MAIN OSCILLATOR LOGIC

To increase processing speed and to reduce clock noise, non-divided logic is implemented for the main oscillator circuit. For this reason, very high resolution waveforms (square signal edges) must be generated in order for the CPU to efficiently process logic operations.

CLOCK STATUS DURING POWER-DOWN MODES

The two power-down modes, Stop mode and Idle mode, affect clock oscillation as follows:

- In Stop mode, the main oscillator "freezes", halting the CPU and peripherals. The contents of the register file and current system register values are retained. Stop mode is released, and the oscillator started, by a reset operation or by an external interrupt with RC-delay noise filter (for KS86C4502/C4504, INT0-INT1).
- In Idle mode, the internal clock signal is gated off to the CPU, but not to interrupt control and the timer. The current CPU status is preserved, including stack pointer, program counter, and flags. Data in the register file is retained. Idle mode is released by a reset or by an interrupt (external or internally-generated).

SYSTEM CLOCK CONTROL REGISTER (CLKCON)

The system clock control register, CLKCON, is located in location D4H. It is read/write addressable and has the following functions:

- Oscillator IRQ wake-up function enable/disable (CLKCON.7)
- Oscillator frequency divide-by value: non-divided, 2, 8, or 16 (CLKCON.4 and CLKCON.3)

The CLKCON register controls whether or not an external interrupt can be used to trigger a Stop mode release (This is called the "IRQ wake-up" function). The IRQ wake-up enable bit is CLKCON.7.

After a reset, the external interrupt oscillator wake-up function is enabled, the main oscillator is activated, and the $f_{OSC}/16$ (the slowest clock speed) is selected as the CPU clock. If necessary, you can then increase the CPU clock speed to f_{OSC} , $f_{OSC}/2$ or $f_{OSC}/8$.

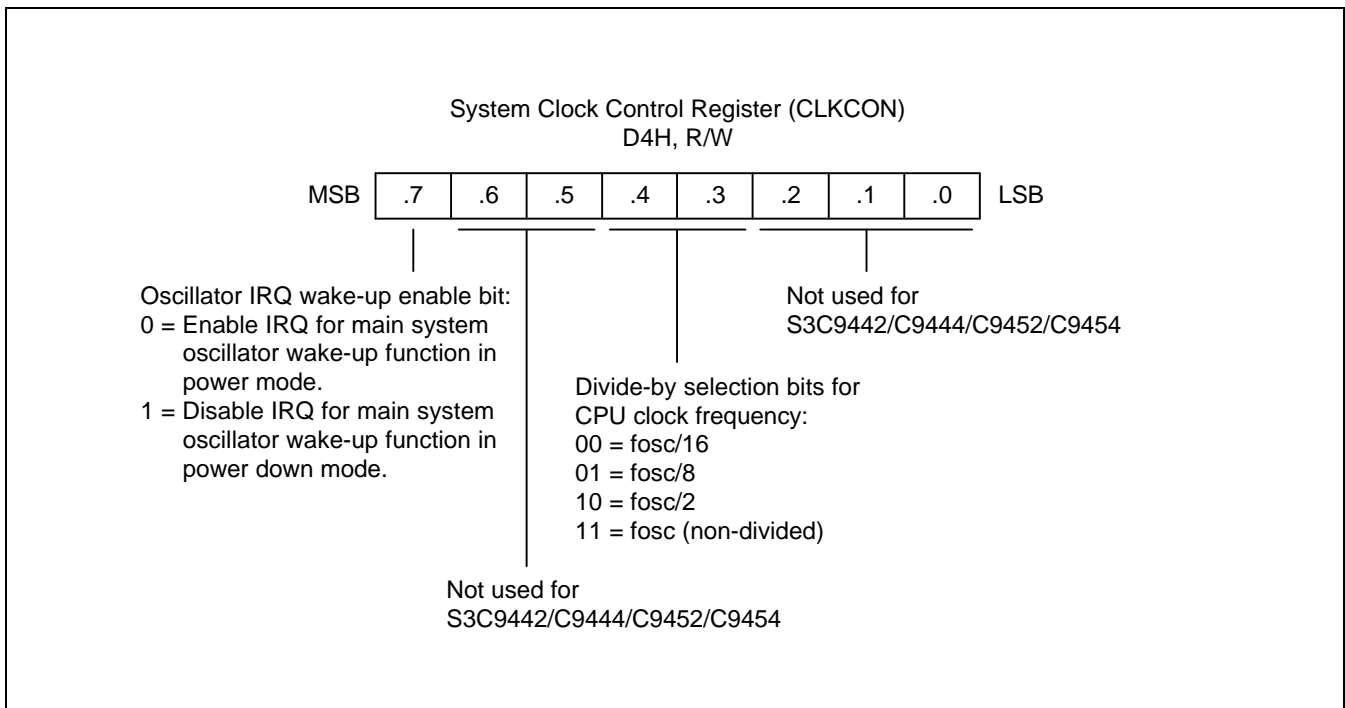


Figure 7-3. System Clock Control Register (CLKCON)

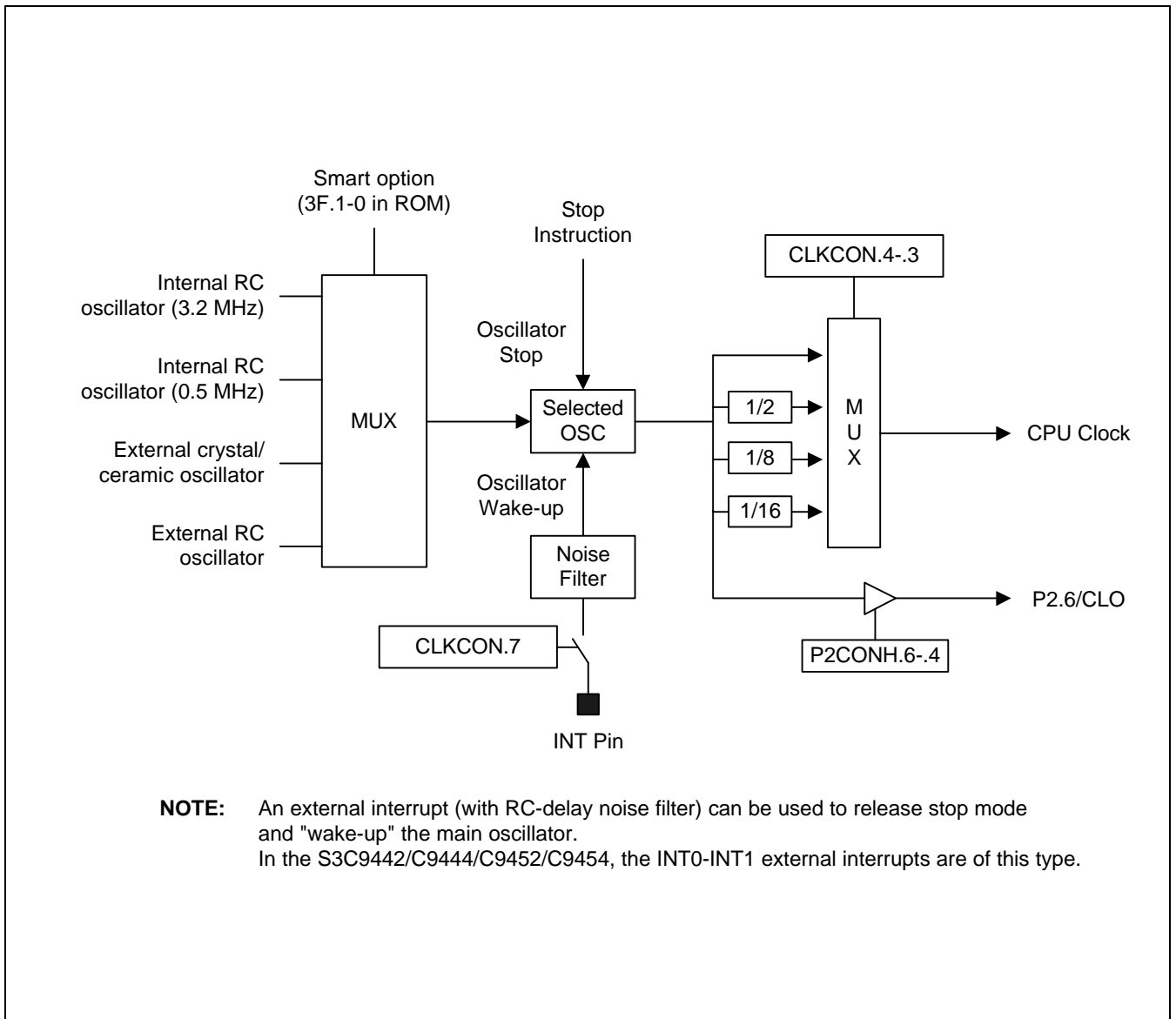


Figure 7-4. System Clock Circuit Diagram

8

RESET and POWER-DOWN

SYSTEM RESET

OVERVIEW

By smart option (3EH.7 in ROM), user can select internal RESET (LVR) or external RESET. In using internal RESET (LVR), RESET pin (P1.2) can be used by normal I/O pin.

The S3C9442/C9444/C9452/C9454 can be RESET in four ways:

- by external power-on-reset
- by the external reset input pin pulled low
- by the digital watchdog peripheral timing out
- by Low Voltage reset (LVR)

During a external power-on reset, the voltage at V_{DD} is High level and the RESET pin is forced to Low level. The RESET signal is input through a Schmitt trigger circuit where it is then synchronized with the CPU clock. This brings the S3C9442/C9444/C9452/C9454 into a known operating status. To ensure correct start-up, the user should take care that reset signal is not released before the V_{DD} level is sufficient to allow MCU operation at the chosen frequency.

The RESET pin must be held to Low level for a minimum time interval after the power supply comes within tolerance in order to allow time for internal CPU clock oscillation to stabilize. The minimum required oscillation stabilization time for a reset is approximately 6.55 ms ($\cong 2^{16}/f_{OSC}$, $f_{OSC} = 10$ MHz).

When a reset occurs during normal operation (with both V_{DD} and RESET at High level), the signal at the RESET pin is forced Low and the reset operation starts. All system and peripheral control registers are then set to their default hardware reset values (see Table 8-1).

The MCU provides a watchdog timer function in order to ensure graceful recovery from software malfunction. If watchdog timer is not refreshed before an end-of-counter condition (overflow) is reached, the internal reset will be activated.

The on-chip Low Voltage reset, features static Reset when supply voltage is below a reference value (Typ. 2.3, 3.0, 3.9 V). Thanks to this feature, external reset circuit can be removed while keeping the application safety. As long as the supply voltage is below the reference value, there is a internal and static RESET. The MCU can start only when the supply voltage rises over the reference value.

NOTE

To program the duration of the oscillation stabilization interval, you must make the appropriate settings to the basic timer control register, BTCON, before entering Stop mode. Also, if you do not want to use the basic timer watchdog function (which causes a system reset if a basic timer counter overflow occurs), you can disable it by writing "1010B" to the upper nibble of BTCON.

MCU Initialization Sequence

The following sequence of events occurs during a reset operation:

- All interrupts are disabled.
- The watchdog function (basic timer) is enabled.
- Ports 0–2 are set to input mode
- Peripheral control and data registers are disabled and reset to their initial values (see Table 8-1).
- The program counter is loaded with the ROM reset address, 0100H.
- When the programmed oscillation stabilization time interval has elapsed, the address stored in ROM location 0100H (and 0101H) is fetched and executed.

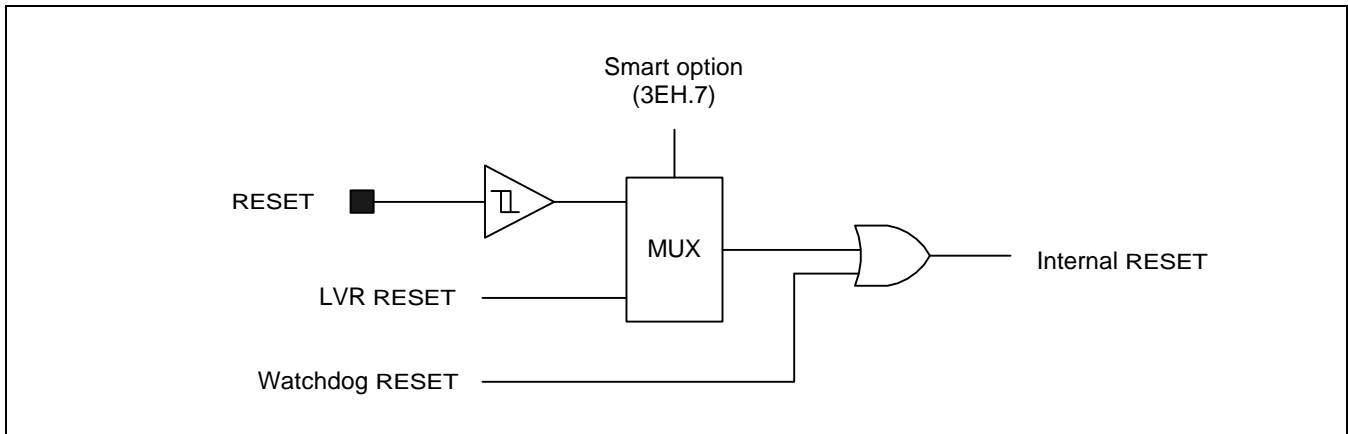


Figure 8-1. Reset Block Diagram

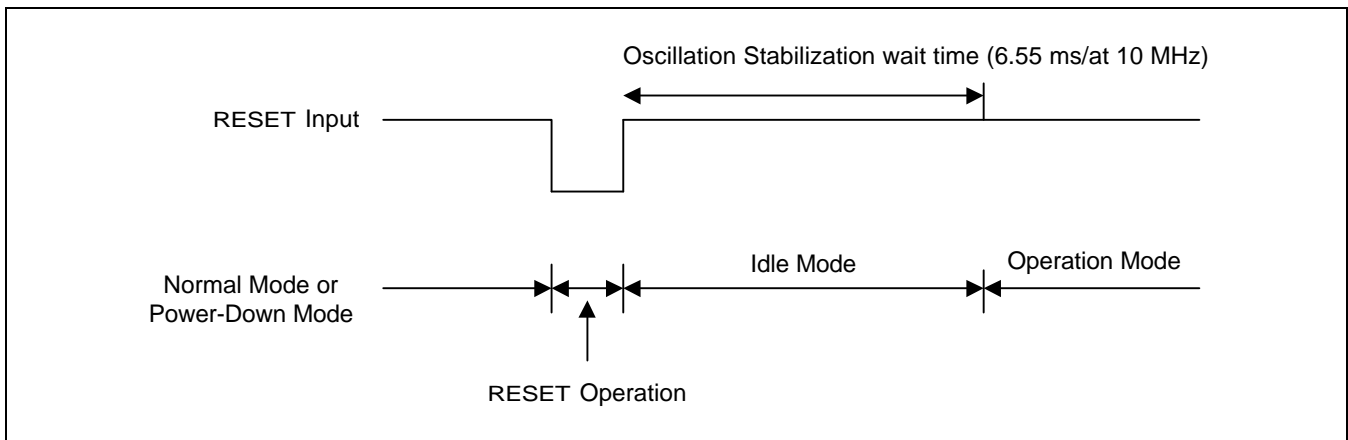


Figure 8-2. Timing for S3C9442/C9444/C9452/C9454 after RESET

POWER-DOWN MODES

STOP MODE

Stop mode is invoked by the instruction STOP (opcode 7FH). In Stop mode, the operation of the CPU and all peripherals is halted. That is, the on-chip main oscillator stops and the supply current is reduced to less than 100 μ A. All system functions are halted when the clock "freezes", but data stored in the internal register file is retained. Stop mode can be released in one of two ways: by a RESET signal or by an external interrupt.

Using RESET to Release Stop Mode

Stop mode is released when the RESET signal is released and returns to High level. All system and peripheral control registers are then reset to their default values and the contents of all data registers are retained. A reset operation automatically selects a slow clock ($f_{OSC}/16$) because CLKCON.3 and CLKCON.4 are cleared to "00B". After the oscillation stabilization interval has elapsed, the CPU executes the system initialization routine by fetching the 16-bit address stored in ROM locations 0100H and 0101H.

Using an External Interrupt to Release Stop Mode

External interrupts with an RC-delay noise filter circuit can be used to release Stop mode (Clock-related external interrupts cannot be used). External interrupts INT0-INT1 in the KS86C4502/C4504 interrupt structure meet this criteria. And, internal interrupt using external clock (timer, SIO etc) can be used to release stop mode also.

Note that when Stop mode is released by an external interrupt, the current values in system and peripheral control registers are not changed. When you use an interrupt to release Stop mode, the CLKCON.3 and CLKCON.4 register values remain unchanged, and the currently selected clock value is used. If you use an external interrupt for Stop mode release, you can also program the duration of the oscillation stabilization interval. To do this, you must put the appropriate value to BTCON register *before* entering Stop mode.

The external interrupt is serviced when the Stop mode release occurs. Following the IRET from the service routine, the instruction immediately following the one that initiated Stop mode is executed.

IDLE MODE

Idle mode is invoked by the instruction IDLE (opcode 6FH). In Idle mode, CPU operations are halted while select peripherals remain active. During Idle mode, the internal clock signal is gated off to the CPU, but not to interrupt logic and timer/counters. Port pins retain the mode (input or output) they had at the time Idle mode was entered.

There are two ways to release Idle mode:

1. Execute a reset. All system and peripheral control registers are reset to their default values and the contents of all data registers are retained. The reset automatically selects a slow clock ($f_{OSC}/16$) because CLKCON.3 and CLKCON.4 are cleared to "00B". If interrupts are masked, a reset is the only way to release Idle mode.
2. Activate any enabled interrupt, causing Idle mode to be released. When you use an interrupt to release Idle mode, the CLKCON.3 and CLKCON.4 register values remain unchanged, and the currently selected clock value is used. The interrupt is then serviced. Following the IRET from the service routine, the instruction immediately following the one that initiated Idle mode is executed.

NOTES

1. Only external interrupts that are not clock-related can be used to release stop mode. To release Idle mode, however, any type of interrupt (that is, internal or external) can be used.
2. Before enter the STOP or IDLE mode, the ADC must be disabled. Otherwise, the STOP or IDLE current will be increased significantly.

HARDWARE RESET VALUES

Table 8-1 lists the values for CPU and system registers, peripheral control registers, and peripheral data registers following a reset operation in normal operating mode.

- A "1" or a "0" shows the reset bit value as logic one or logic zero, respectively.
- An "x" means that the bit value is undefined following a reset.
- A dash ("-") means that the bit is either not used or not mapped.

Table 8-1. Register Values after a Reset

Register name	Mnemonic	Address & Location		RESET value (Bit)								
		Address	R/W	7	6	5	4	3	2	1	0	
Timer 0 counter register	T0CNT	D0H	R	0	0	0	0	0	0	0	0	0
Timer 0 data register	T0DATA	D1H	R/W	1	1	1	1	1	1	1	1	1
Timer 0 control register	T0CON	D2H	R/W	0	0	-	-	0	-	0	0	0
Location D3H is not mapped												
Clock control register	CLKCON	D4H	R/W	0	-	-	0	0	-	-	-	-
System flags register	FLAGS	D5H	R/W	x	x	x	x	-	-	-	-	-
Locations D6H–D8H are not mapped												
Stack pointer register	SP	D9H	R/W	x	x	x	x	x	x	x	x	x
Location DAH is not mapped												
MDS special register	MDSREG	DBH	R/W	0	0	0	0	0	0	0	0	0
Basic timer control register	BTCON	DCH	R/W	0	0	0	0	0	0	0	0	0
Basic timer counter	BTCNT	DDH	R	0	0	0	0	0	0	0	0	0
Test mode control register	FTSTCON	DEH	W	-	-	0	0	0	0	0	0	0
System mode register	SYM	DFH	R/W	-	-	-	-	-	0	0	0	0

NOTE: - : Not mapped or not used, x: undefined

Table 8-1. Register Values After a Reset (Continued)

Register Name	Mnemonic	Address Hex	R/W	Bit Values After RESET								
				7	6	5	4	3	2	1	0	
Port 0 data register	P0	E0H	R/W	0	0	0	0	0	0	0	0	0
Port 1 data register	P1	E1H	R/W	–	–	–	–	–	0	0	0	0
Port 2 data register	P2	E2H	R/W	–	0	0	0	0	0	0	0	0
Locations E3H–E5H are not mapped												
Port 0 control register (High byte)	P0CONH	E6H	R/W	0	0	0	0	0	0	0	0	0
Port 0 control register	P0CON	E7H	R/W	0	0	0	0	0	0	0	0	0
Port 0 interrupt pending register	P0PND	E8H	R/W	–	–	–	–	0	0	0	0	0
Port 1 control register	P1CON	E9H	R/W	0	0	–	–	0	0	0	0	0
Port 2 control register (High byte)	P2CONH	EAH	R/W	–	0	0	0	0	0	0	0	0
Port 2 control register (Low byte)	P2CONL	EBH	R/W	0	0	0	0	0	0	0	0	0
Locations ECH–F1H are not mapped												
PWM data register	PWMDATA	F2H	R/W	0	0	0	0	0	0	0	0	0
PWM control register	PWMCON	F3H	R/W	0	0	–	0	0	0	0	0	0
STOP control register	STOPCON	F4H	R/W	0	0	0	0	0	0	0	0	0
Locations F5H–F6H are not mapped												
A/D control register	ADCON	F7H	R/W	0	0	0	0	0	0	0	0	0
A/D converter data register (High)	ADDATAH	F8H	R	x	x	x	x	x	x	x	x	x
A/D converter data register (Low)	ADDATAL	F9H	R	0	0	0	0	0	0	0	x	x
Locations FAH–FFH are not mapped												

NOTE: – : Not mapped or not used, x: undefined

 **PROGRAMMING TIP — Sample S3C9454 Initialization Routine**

```

;-----<< Interrupt Vector Address >>
      ORG      0000H
      VECTOR   00H,INT_9454      ; S3C9454 has only one interrupt vector

;-----<< Smart Option >>
      ORG      003CH
      DB       00H      ; 003CH, must be initialized to 0
      DB       00H      ; 003DH, must be initialized to 0
      DB       0E7H     ; 003EH, enable LVR (2.3 V)
      DB       03H      ; 003FH, internal RC (3.2 MHz in VDD = 5 V )

;-----<< Initialize System and Peripherals >>
RESET:  ORG      0100H
        DI       ; disable interrupt
        LD       BTCON,#10100011B ; Watch-dog disable
        LD       CLKCON,#00011000B ; Select non-divided CPU clock
        LD       SP,#0C0H      ; Stack pointer must be set


        LD       P0CONH,#10101010B ;
        LD       P0CONL,#10101010B ; P0.0–P0.7 push-pull output
        LD       P1CON,#00001010B  ; P1.0–P1.1 push-pull output
        LD       P2CONH,#01001010B ;
        LD       P2CONL,#10101010B ; P2.0–P2.6 push-pull output

;-----<< Timer 0 settings >>
        LD       T0DATA,#50H      ; CPU = 11.0592 MHz, interrupt interval = 2 msec
        LD       T0CON,#01001010B ; fOSC/256, Timer 0 interrupt enable

;-----<< Clear all data registers from 00h to 5Fh >>
RAM_CLR: LD       R0,#0      ; RAM clear
         CLR      @R0
         INC      R0
         CP       R0,#0BFH
         JP       ULE,RAM_CLR

;-----<< Initialize other registers >>
        .
        .
        .
        EI       ; Enable interrupt

```

 **PROGRAMMING TIP — Sample S3C9454 Initialization Routine (Continued)**

```

;-----<< Main loop >>
MAIN:    NOP                ; Start main loop
        LD      BTCON,#02H  ; Enable watchdog function
                          ; Basic counter (BTCNT) clear
        .
        .
        CALL   KEY_SCAN    ;
        .
        .
        CALL   LED_DISPLAY ;
        .
        .
        CALL   JOB         ;
        .
        .
        JR     T,MAIN      ;

;-----<< Subroutines >>
KEY_SCAN: NOP              ;
        .
        .
        RET

LED_DISPLAY: NOP          ;
        .
        .
        RET

JOB:     NOP              ;
        .
        .
        RET

```

 **PROGRAMMING TIP — Sample S3C9454 Initialization Routine (Continued)**

```

;-----<< Interrupt Service Routines >>           ; Interrupt enable bit and pending bit check
INT_9454:  TM      T0CON,#00000010B                ; Timer0 interrupt enable check
          JR      Z,NEXT_CHK1                      ;
          TM      T0CON,#00000001B                ; If timer0 interrupt was occurred,
          JP      NZ,INT_TIMER0                    ; T0CON.0 bit would be set.

NEXT_CHK1:
          TM      PWMCOM,#00000010B              ; PWM overflow interrupt enable check
          JR      Z,NEXT_CHK2                      ;
          TM      P0PND,#00000001B                ;
          JP      NZ,PWMOVF_INT                    ;

NEXT_CHK2:
          TM      P0PND,#00000010B                ; INT0 interrupt enable check
          JR      Z,NEXT_CHK3                      ;
          TM      P0PND,#00000001B                ;
          JP      NZ,INT0_INT                      ;

NEXT_CHK3:
          TM      P0PND,#00001000B                ; INT1 interrupt enable check
          JP      Z,END_INT                        ;
          TM      P0PND,#00000100B                ;
          JP      NZ,INT1_INT                      ;
          IRET                                     ; Interrupt return

END_INT   ; IRET

;-----<< Timer0 interrupt service routine >
INT_TIMER0:
          •
          •
          AND     T0CON,#11110110B                ; Pending bit clear
          IRET                                     ; Interrupt return

;-----<< PWM overflow interrupt service routine >
PWMOVF_INT:
          •
          •
          AND     PWMCON,#11110110B              ; Pending bit clear
          IRET                                     ; Interrupt return

```

 **PROGRAMMING TIP — Sample S3C9454 Initialization Routine (Continued)**

```
;-----< External interrupt0 service routine >
```

```
INT0_INT:  •
           •
           AND      P0PND,#11111110B    ; INT0 Pending bit clear
           IRET                                ; Interrupt return
```

```
;-----< External interrupt1 service routine >
```

```
INT1_INT:  •
           •
           AND      P0PND,#11111011B    ; INT1 Pending bit clear
           IRET                                ; Interrupt return
           •
           •
           END                                ;
```

9

I/O PORTS

OVERVIEW

The S3C9442/C9444/C9452/C9454 has three I/O ports: with 18 pins total. You access these ports directly by writing or reading port data register addresses.

All ports can be configured as LED drive. (High current output: typical 10 mA)

Table 9-1. S3C9442/C9444/C9452/C9454 Port Configuration Overview

Port	Function Description	Programmability
0	Bit-programmable I/O port for schmitt trigger input or push-pull output. Pull-up resistors are assignable by software. Port 0 pins can also be used as alternative function. (ADC input, external interrupt input).	Bit
1	Bit-programmable I/O port for schmitt trigger input or push-pull, open-drain output. Pull-up or pull-down resistors are assignable by software. Port 1 pins can also oscillator input/output or reset input by smart option. P1.2 is input only.	Bit
2	Bit-programmable I/O port for schmitt trigger input or push-pull, open-drain output. Pull-up resistor are assignable by software. Port 2 can also be used as alternative function (ADC input, CLO, T0 clock output)	Bit

PORT DATA REGISTERS

Table 9-2 gives you an overview of the port data register names, locations, and addressing characteristics. Data registers for ports 0-2 have the structure shown in Figure 9-1.

Table 9-2. Port Data Register Summary

Register Name	Mnemonic	Hex	R/W
Port 0 data register	P0	E0H	R/W
Port 1 data register	P1	E1H	R/W
Port 2 data register	P2	E2H	R/W

NOTE: A reset operation clears the P0–P2 data register to "00H".

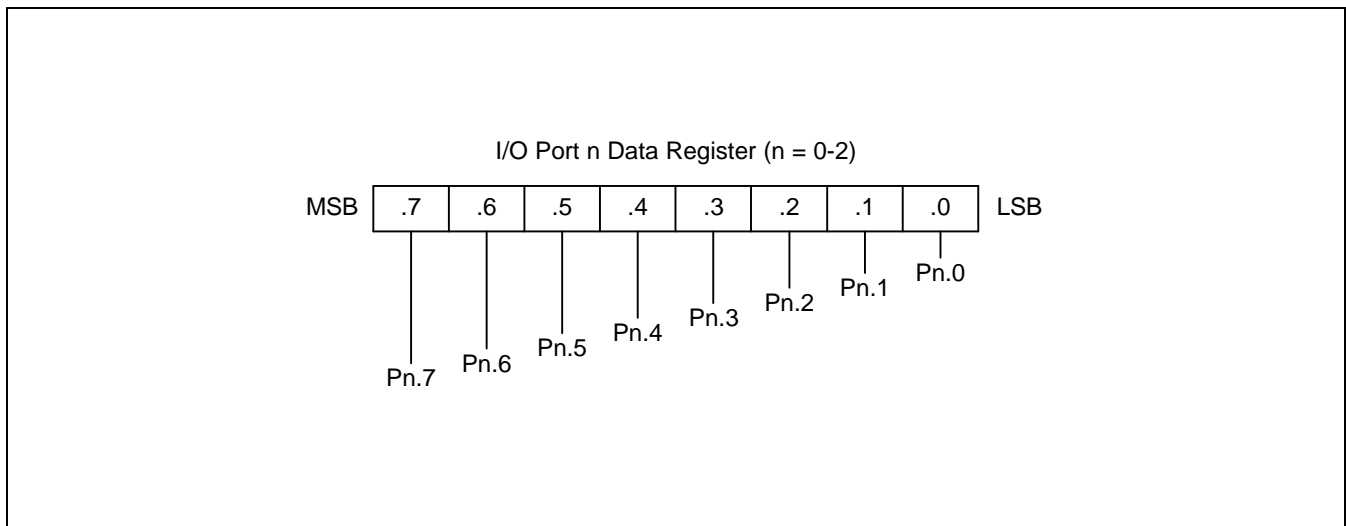


Figure 9-1. Port Data Register Format

PORT 0

Port 0 is a bit-programmable, general-purpose, I/O ports. You can select normal input or push-pull output mode. In addition, you can configure a pull-up resistor to individual pins using control register settings. It is designed for high-current functions such as LED direct drive. Part 0 pins can also be used as alternative functions (ADC input, external interrupt input and PWM output).

Two control registers are used to control Port 0: P0CONH (E6H) and P0CONL (E7H).

You access port 0 directly by writing or reading the corresponding port data register, P0 (E0H).

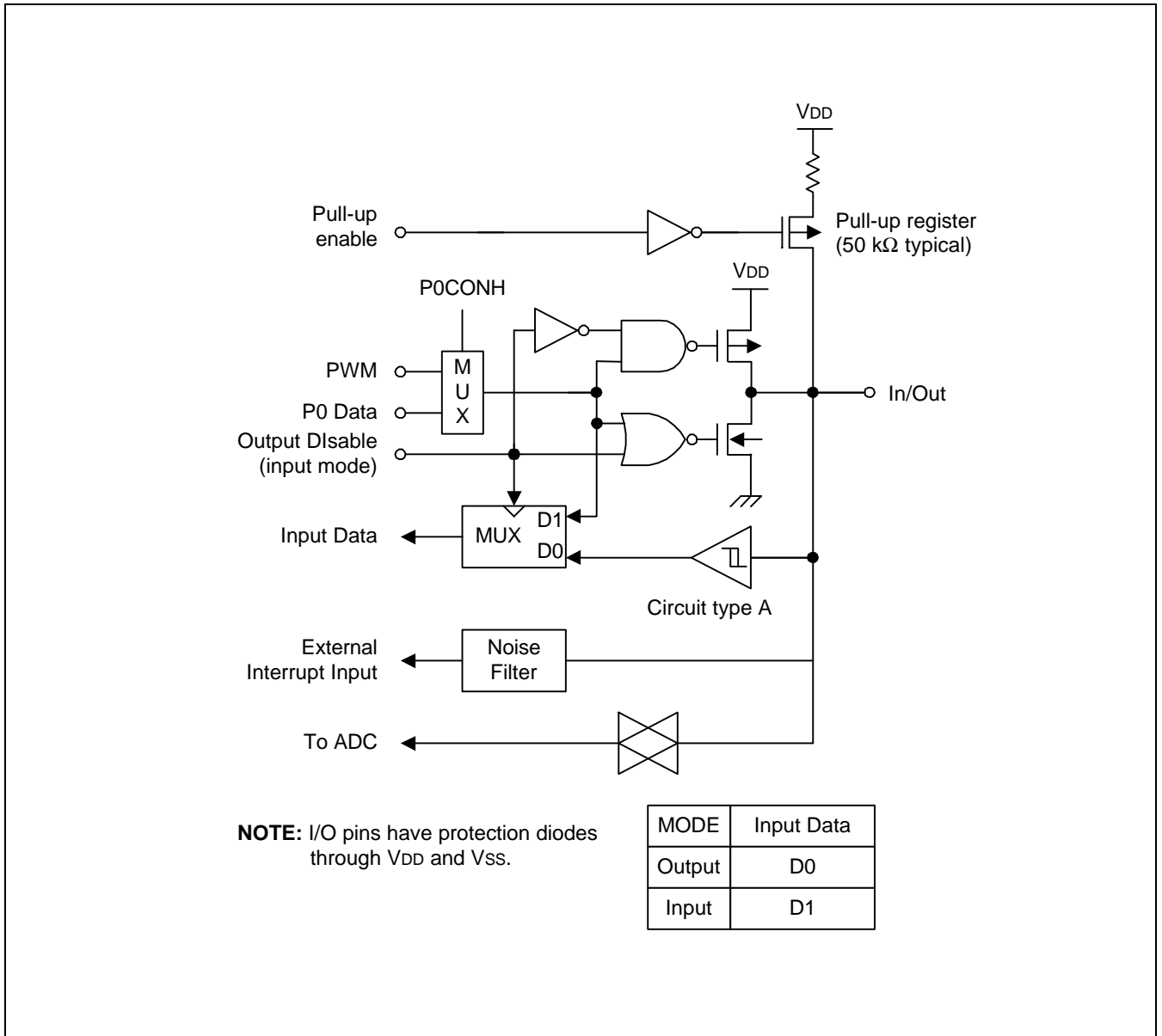


Figure 9-2. Port 0 Circuit Diagram

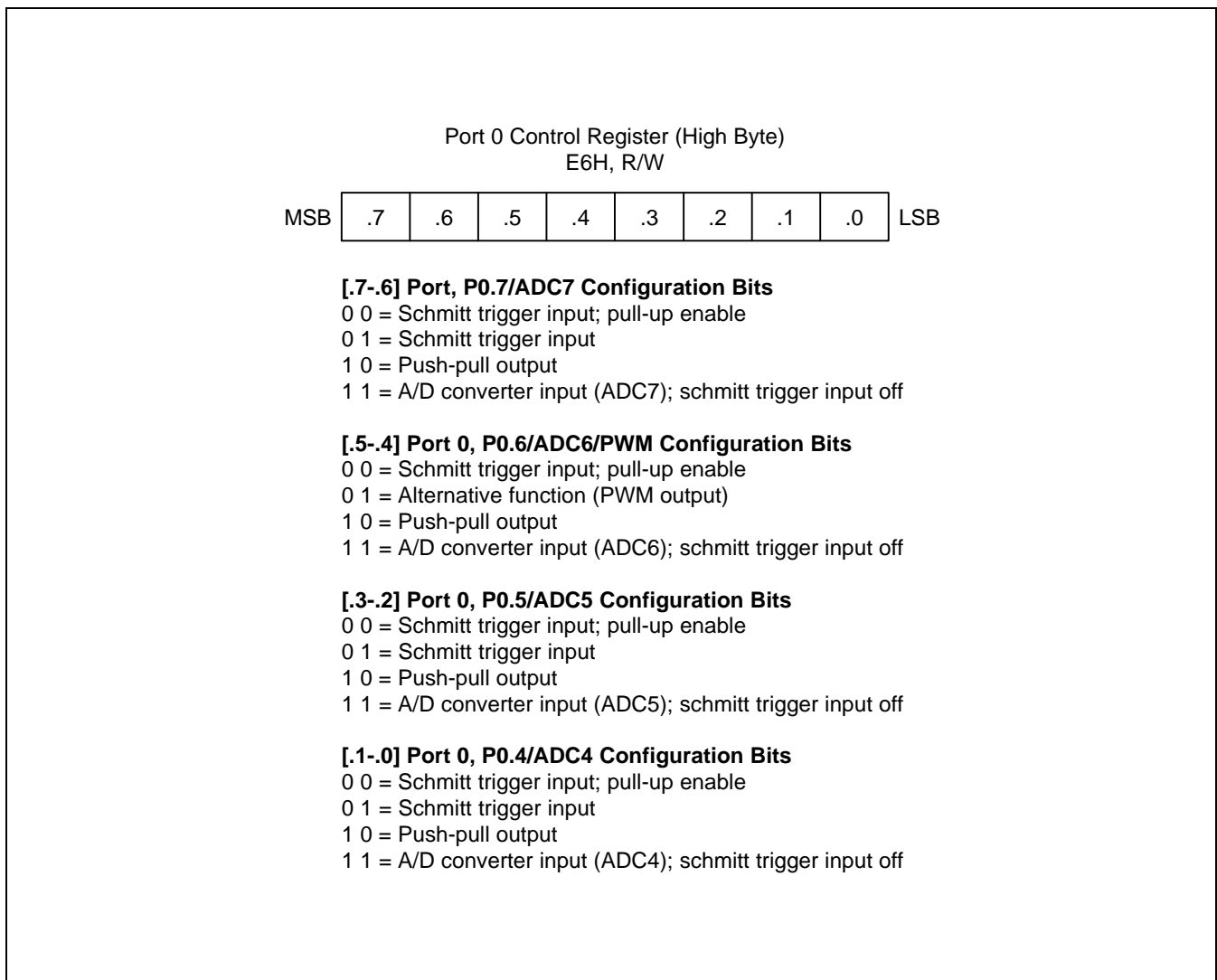


Figure 9-3. Port 0 Control Register (P0CONH, High Byte)

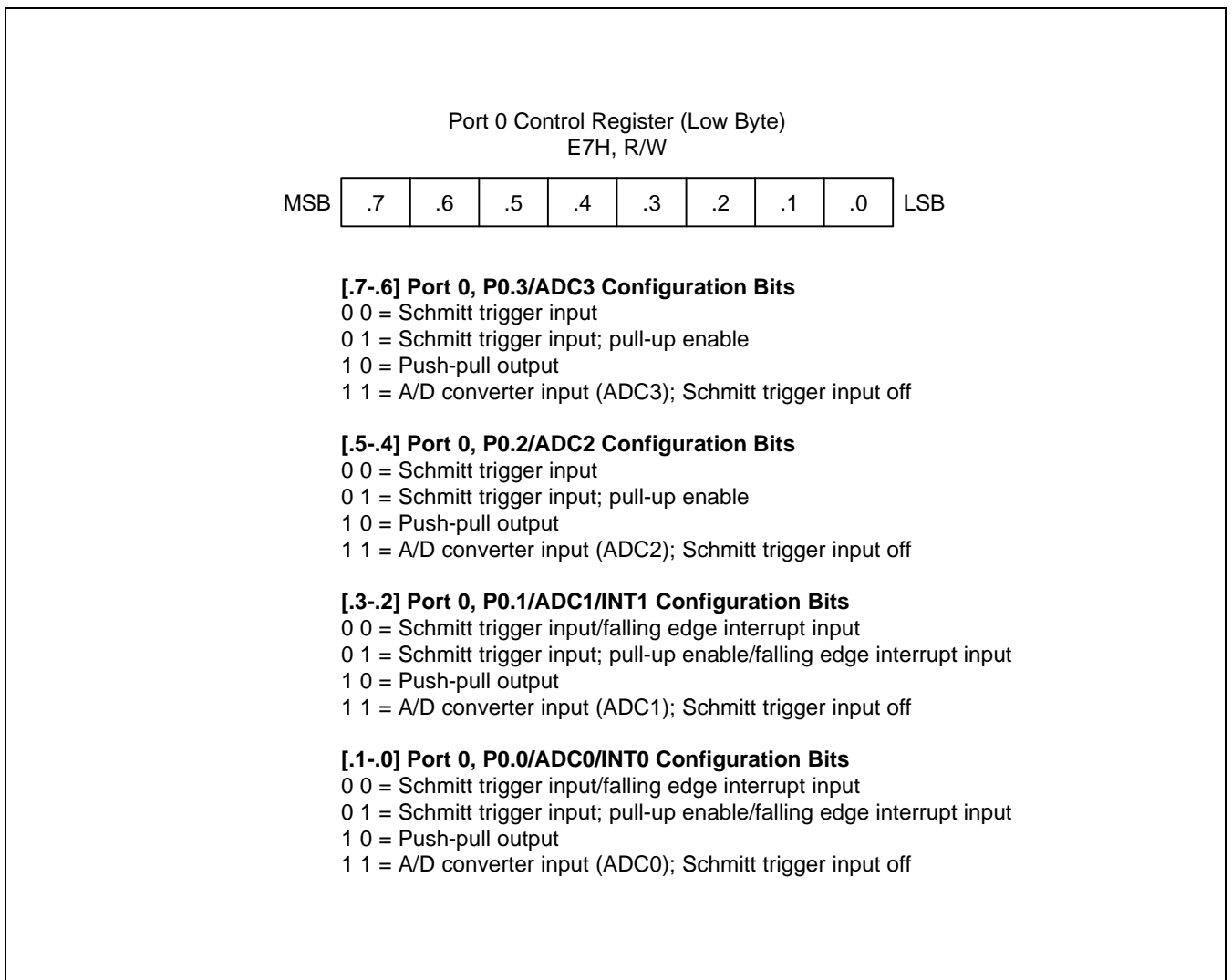


Figure 9-4. Port 0 Control Register (P0CONL, Low Byte)

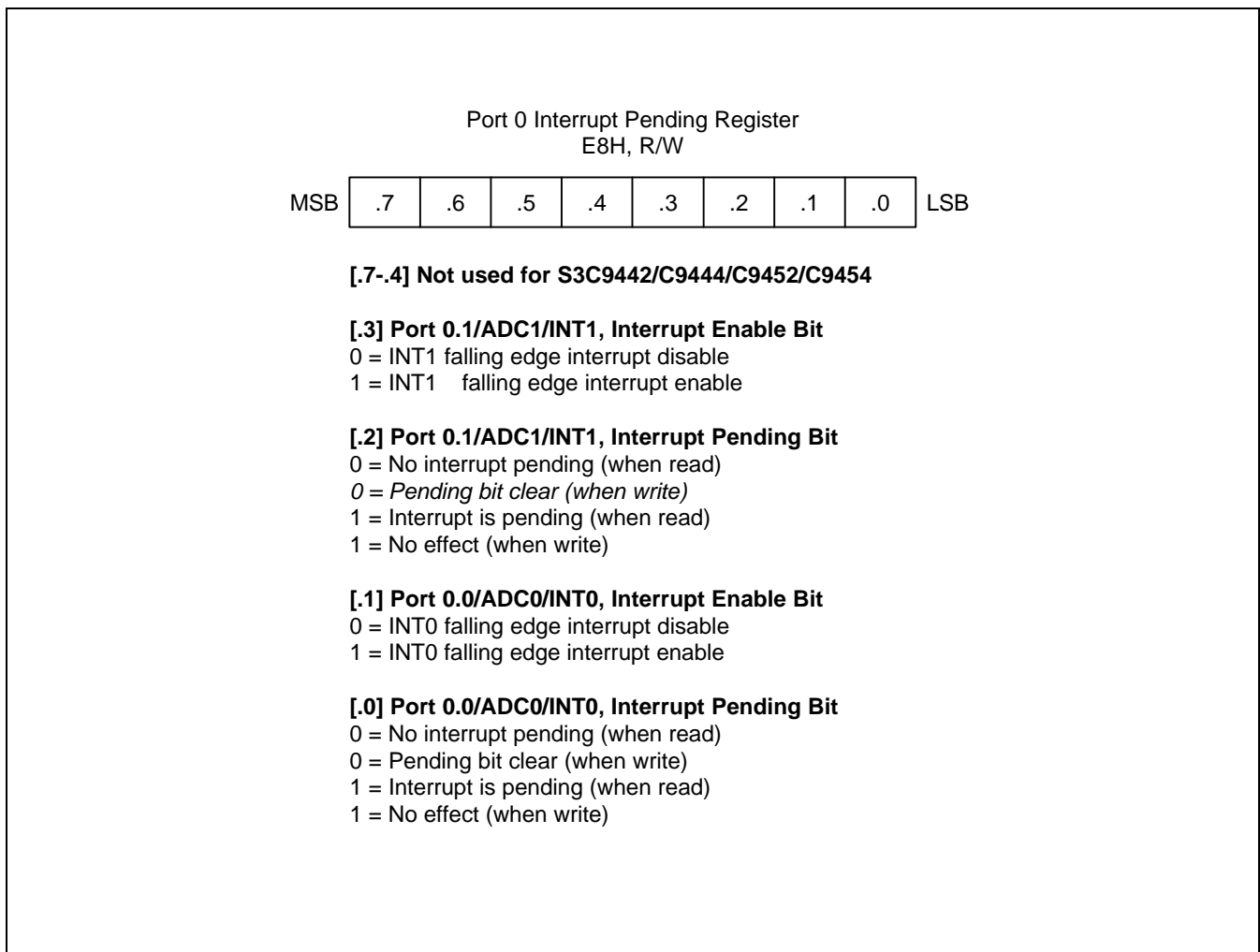


Figure 9-5. Port 0 Interrupt Pending Registers (P0PND)

PORT 1

Port 1, is a 3-bit I/O port with individually configurable pins. It can be used for general I/O port (Schmitt trigger input mode, push-pull output mode or n-channel open-drain output mode). In addition, you can configure a pull-up and pull-down resistor to individual pin using control register settings. It is designed for high-current functions such as LED direct drive.

P1.0, P1.1 are used for oscillator input/output by smart option. Also, P1.2 is used for RESET pin by smart option.

One control register is used to control port 1: P1CON (E9H).

You address port 1 bits directly by writing or reading the port 1 data register, P1 (E1H). When you use external oscillator, P1.0, P1.1 must be set to output port to prevent current consumption.

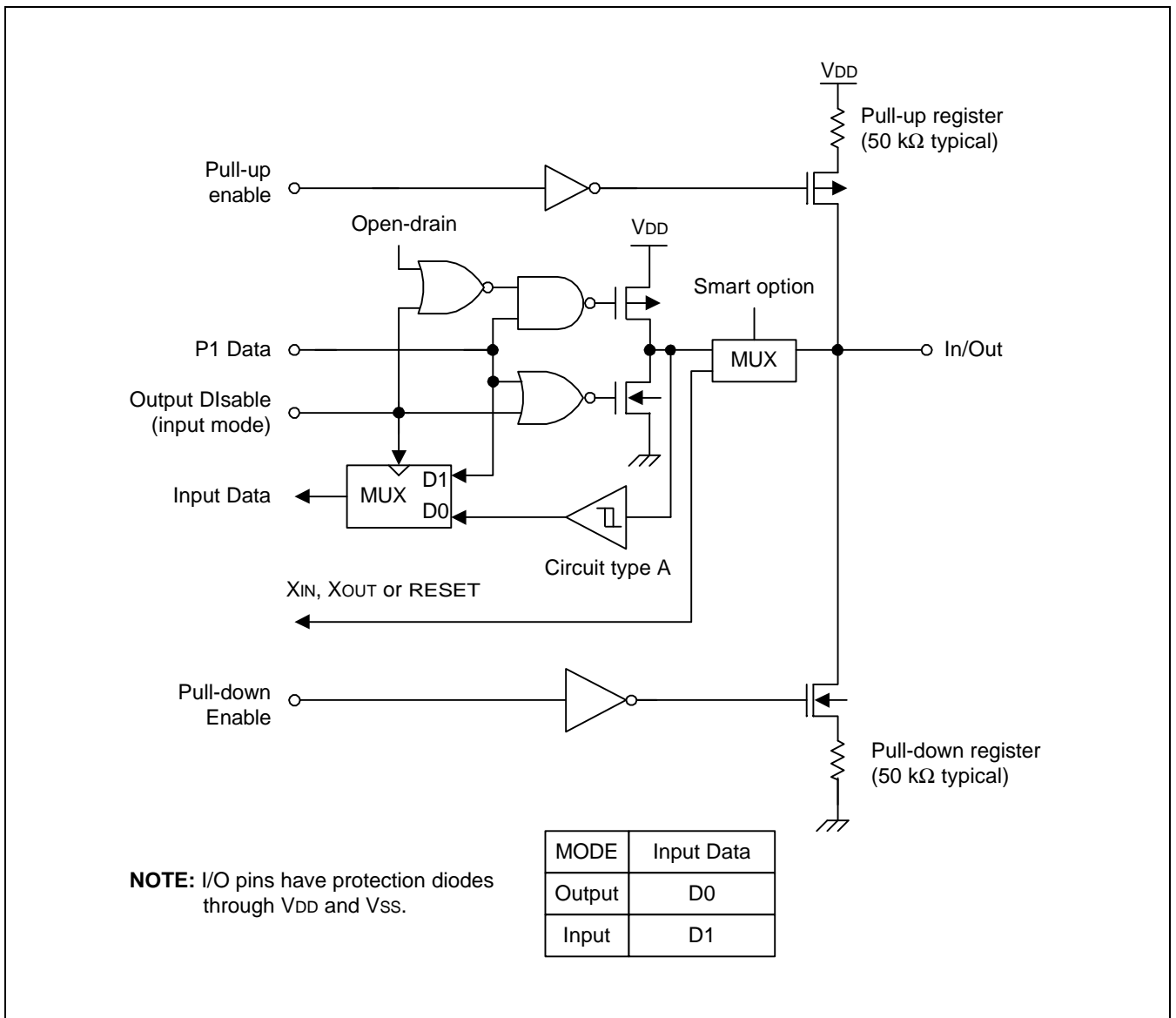


Figure 9-6. Port 1 Circuit Diagram

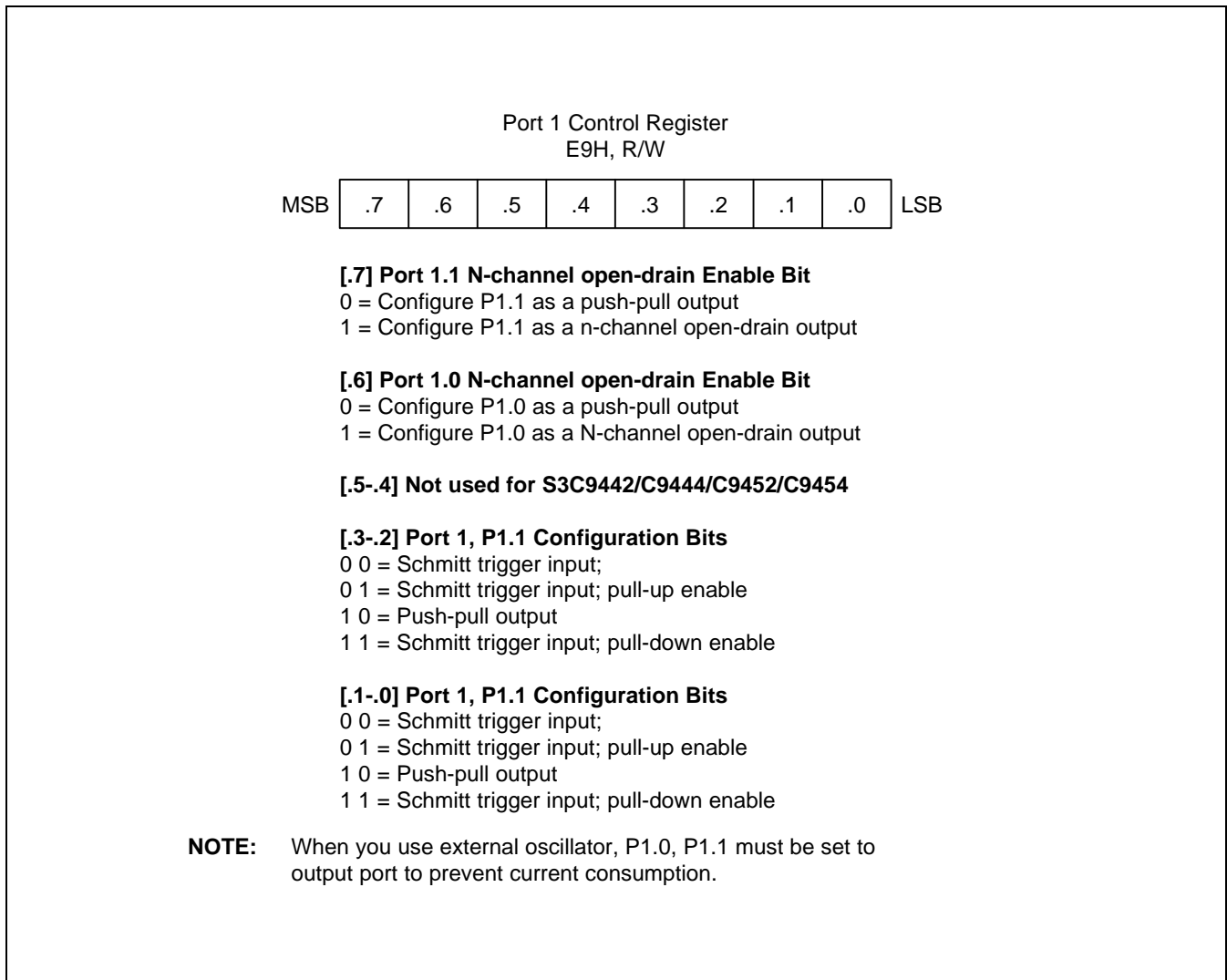


Figure 9-7. Port 1 Control Register (P1CON)

PORT 2

Port 2 is a 7-bit I/O port with individually configurable pins. It can be used for general I/O port (schmitt trigger input mode, push-pull output mode or N-channel open-drain output mode). You can also use some pins of port 2 ADC input, CLO output and T0 clock output. In addition, you can configure a pull-up resistor to individual pins using control register settings. It is designed for high-current functions such as LED direct drive.

You address port 2 bits directly by writing or reading the port 2 data register, P2 (E2H). The port 2 control register, P2CONH and P2CONL is located at addresses EAH, EBH respectively.

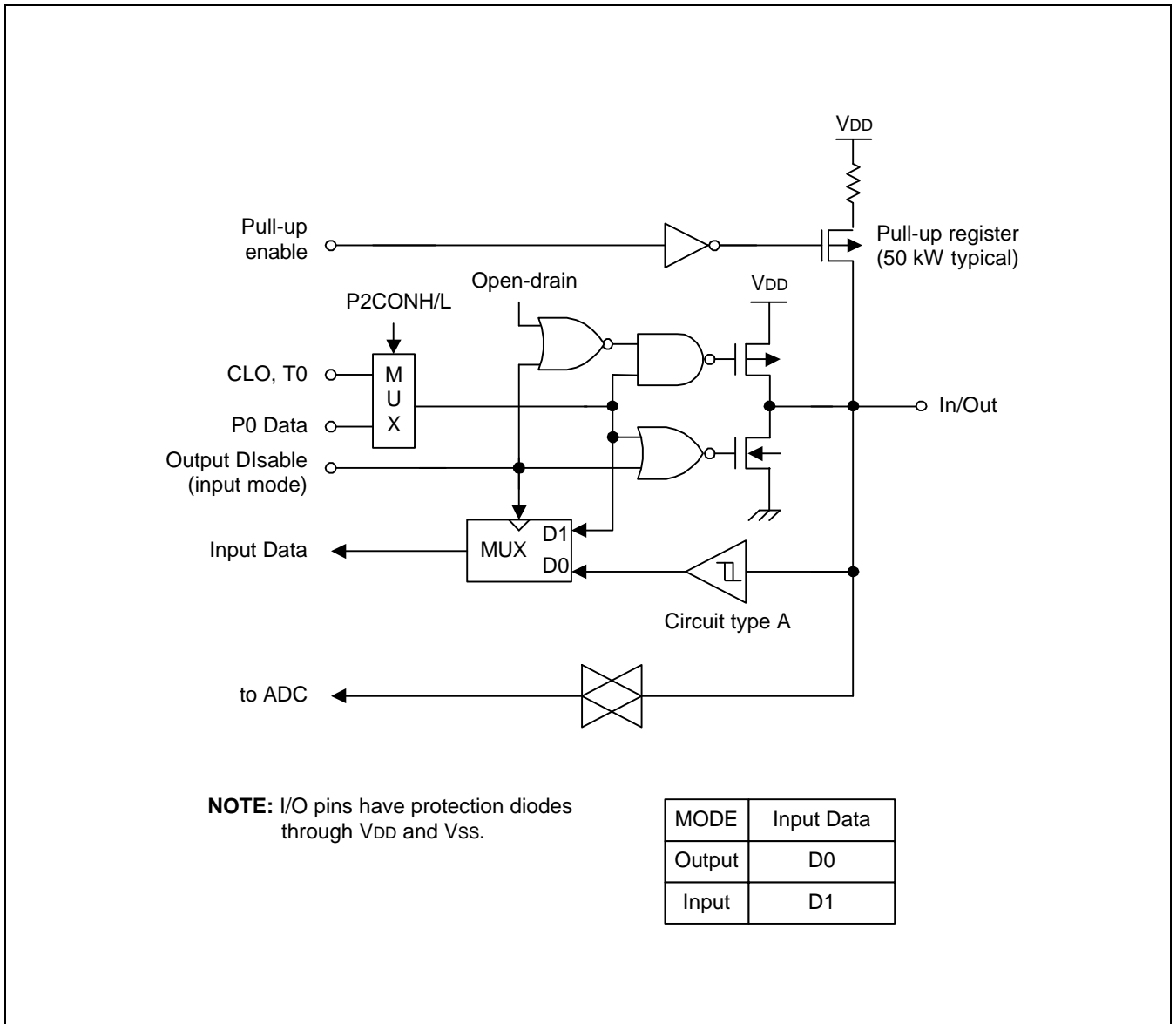


Figure 9-8. Port 2 Circuit Diagram

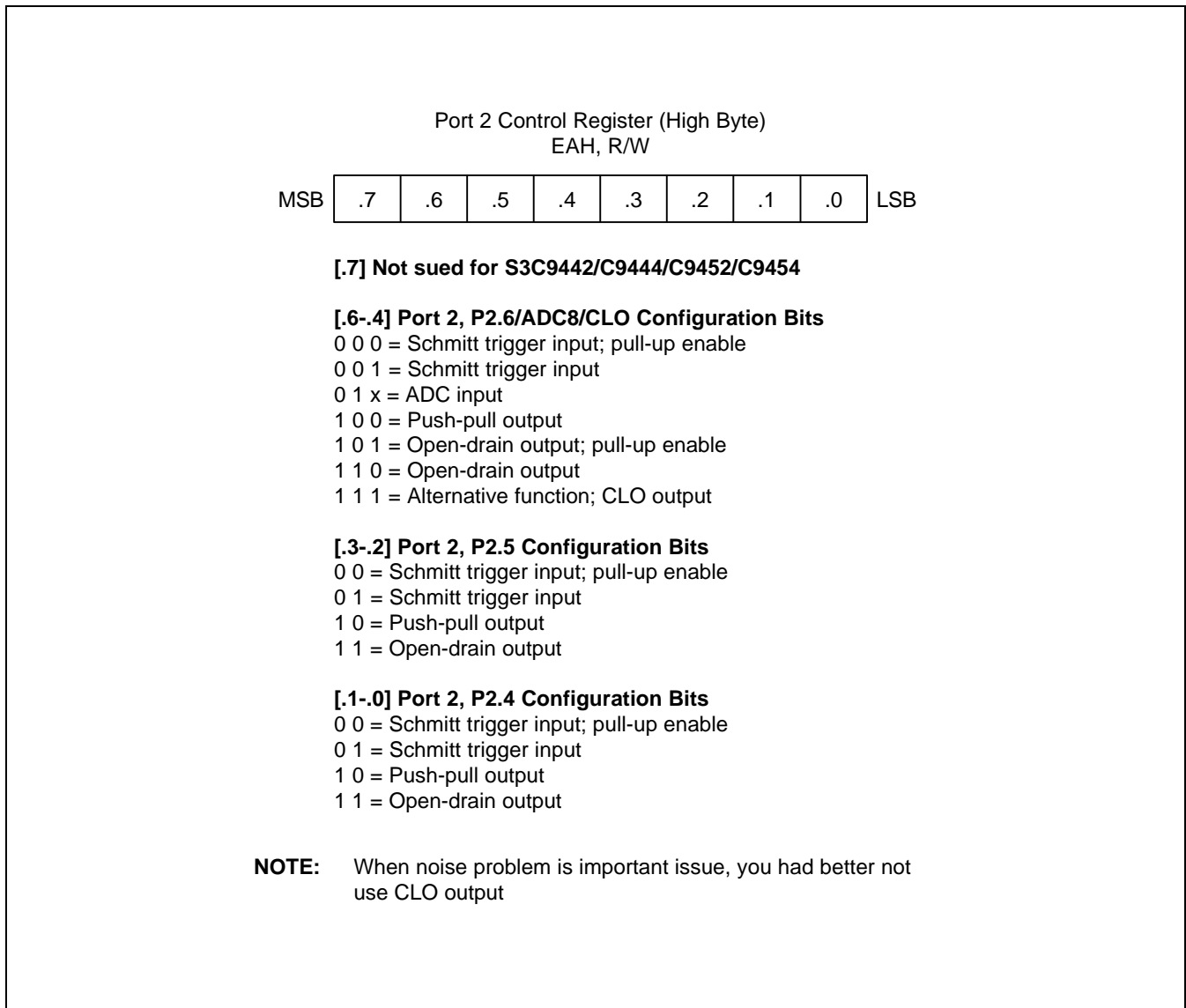


Figure 9-9. Port 2 Control Register (P2CONH, High Byte)

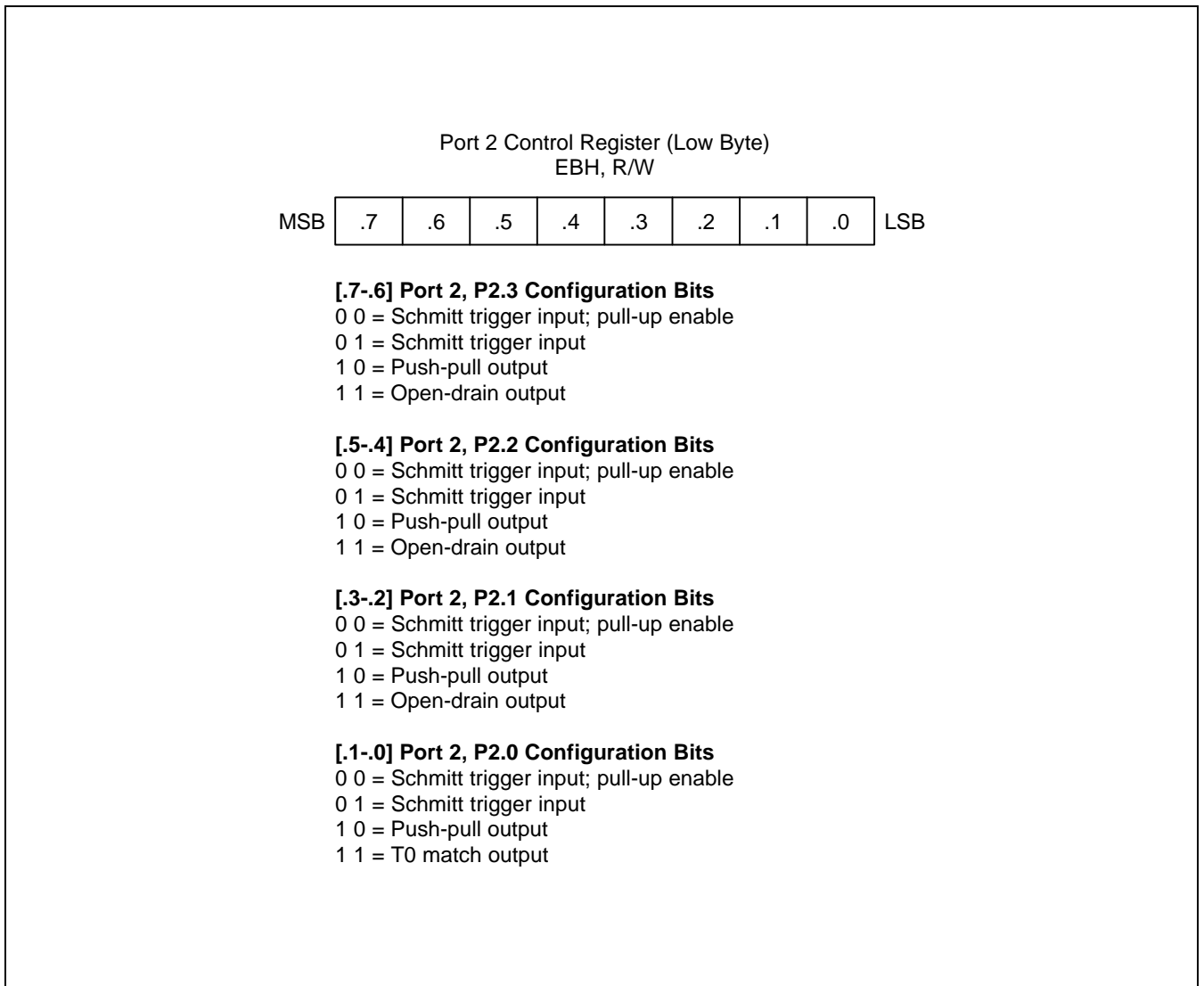


Figure 9-10. Port 2 Control Register (P2CONL, Low Byte)

10

BASIC TIMER and TIMER 0

MODULE OVERVIEW

The S3C9442/C9444/C9452/C9454 has two default timers: an 8-bit basic timer, one 8-bit general-purpose timer/counter, called timer 0.

Basic Timer (BT)

You can use the basic timer (BT) in two different ways:

- As a watchdog timer to provide an automatic reset mechanism in the event of a system malfunction.
- To signal the end of the required oscillation stabilization interval after a reset or a Stop mode release. The functional components of the basic timer block are:
 - Clock frequency divider (f_{OSC} divided by 4096, 1024, or 128) with multiplexer
 - 8-bit basic timer counter, BTCNT (DDH, read-only)
 - Basic timer control register, BTCON (DCH, read/write)

Timer 0

Timer 0 has the following functional components:

- Clock frequency divider (f_{OSC} divided by 4096, 256, 8, or f_{OSC}) with multiplexer
- 8-bit counter (T0CNT), 8-bit comparator, and 8-bit data register (T0DATA)
- Timer 0 control register (T0CON)

BASIC TIMER (BT)

BASIC TIMER CONTROL REGISTER (BTCON)

The basic timer control register, BTCON, is used to select the input clock frequency, to clear the basic timer counter and frequency dividers, and to enable or disable the watchdog timer function.

A reset clears BTCON to "00H". This enables the watchdog function and selects a basic timer clock frequency of $f_{OSC}/4096$. To disable the watchdog function, you must write the signature code "1010B" to the basic timer register control bits BTCON.7–BTCON.4.

The 8-bit basic timer counter, BTCNT, can be cleared during normal operation by writing a "1" to BTCON.1. To clear the frequency dividers for both the basic timer input clock and the timer 0 clock, you write a "1" to BTCON.0.

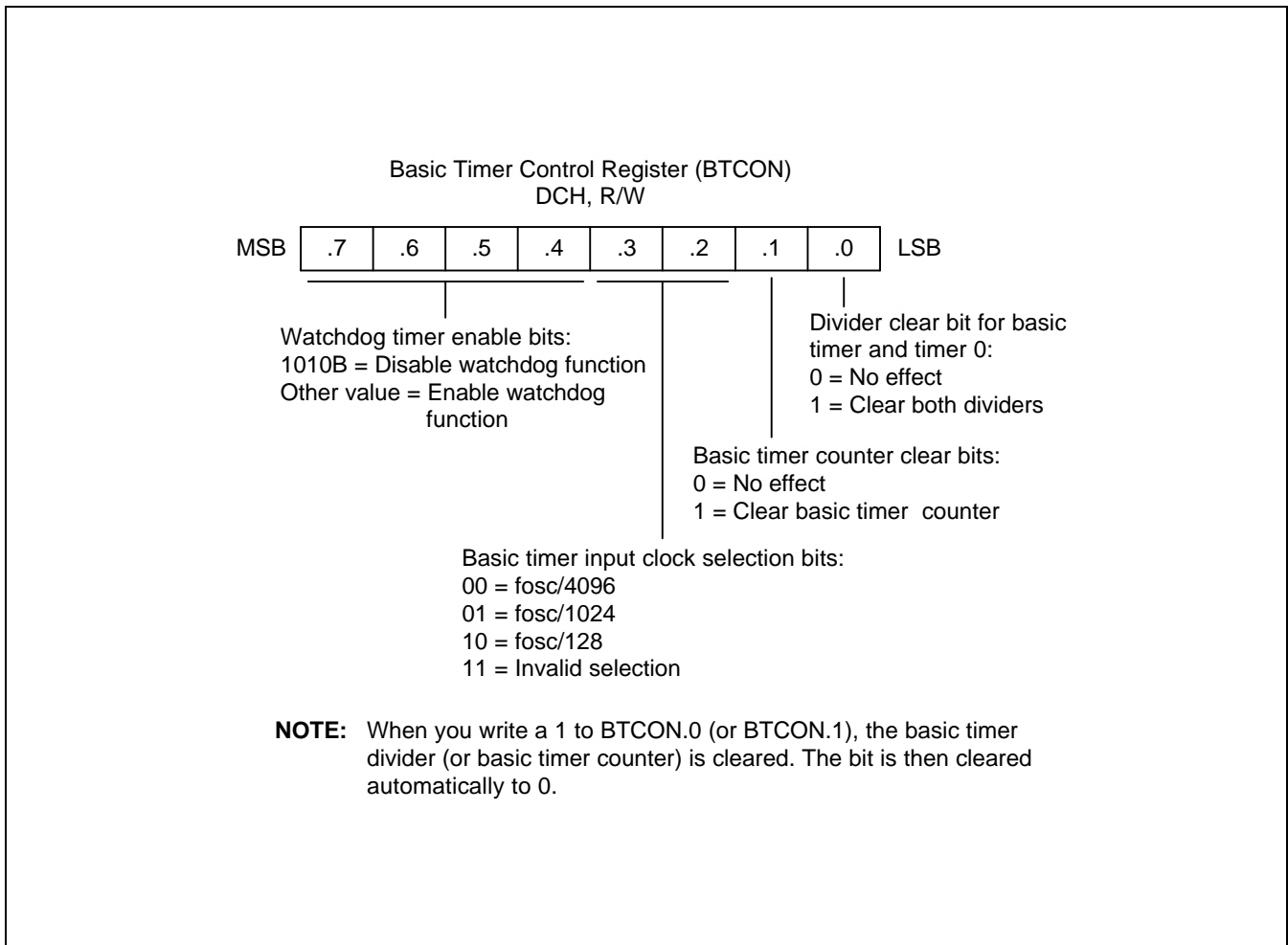


Figure 10-1. Basic Timer Control Register (BTCON)

BASIC TIMER FUNCTION DESCRIPTION

Watchdog Timer Function

You can program the basic timer overflow signal (BTOVF) to generate a reset by setting BTCON.7–BTCON.4 to any value other than "1010B" (The "1010B" value disables the watchdog function). A reset clears BTCON to "00H", automatically enabling the watchdog timer function. A reset also selects the oscillator clock divided by 4096 as the BT clock.

A reset whenever a basic timer counter overflow occurs. During normal operation, the application program must prevent the overflow, and the accompanying reset operation, from occurring. To do this, the BTCNT value must be cleared (by writing a "1" to BTCON.1) at regular intervals.

If a system malfunction occurs due to circuit noise or some other error condition, the BT counter clear operation will not be executed and a basic timer overflow will occur, initiating a reset. In other words, during normal operation, the basic timer overflow loop (a bit 7 overflow of the 8-bit basic timer counter, BTCNT) is always broken by a BTCNT clear instruction. If a malfunction does occur, a reset is triggered automatically.

Oscillation Stabilization Interval Timer Function

You can also use the basic timer to program a specific oscillation stabilization interval following a reset or when Stop mode has been released by an external interrupt.

In Stop mode, whenever a reset or an external interrupt occurs, the oscillator starts. The BTCNT value then starts increasing at the rate of $f_{OSC}/4096$ (for reset), or at the rate of the preset clock source (for an external interrupt). When BTCNT.4 is set, a signal is generated to indicate that the stabilization interval has elapsed and to gate the clock signal off to the CPU so that it can resume normal operation.

In summary, the following events occur when Stop mode is released:

1. During Stop mode, a external power-on reset or an external interrupt occurs to trigger the Stop mode release and oscillation starts.
2. If a external power-on reset occurred, the basic timer counter will increase at the rate of $f_{OSC}/4096$. If an external interrupt is used to release Stop mode, the BTCNT value increases at the rate of the preset clock source.
3. Clock oscillation stabilization interval begins and continues until bit 4 of the basic timer counter is set.
4. When a BTCNT.4 is set, normal CPU operation resumes.

Figure 10-2 and 10-3 shows the oscillation stabilization time on RESET and STOP mode release

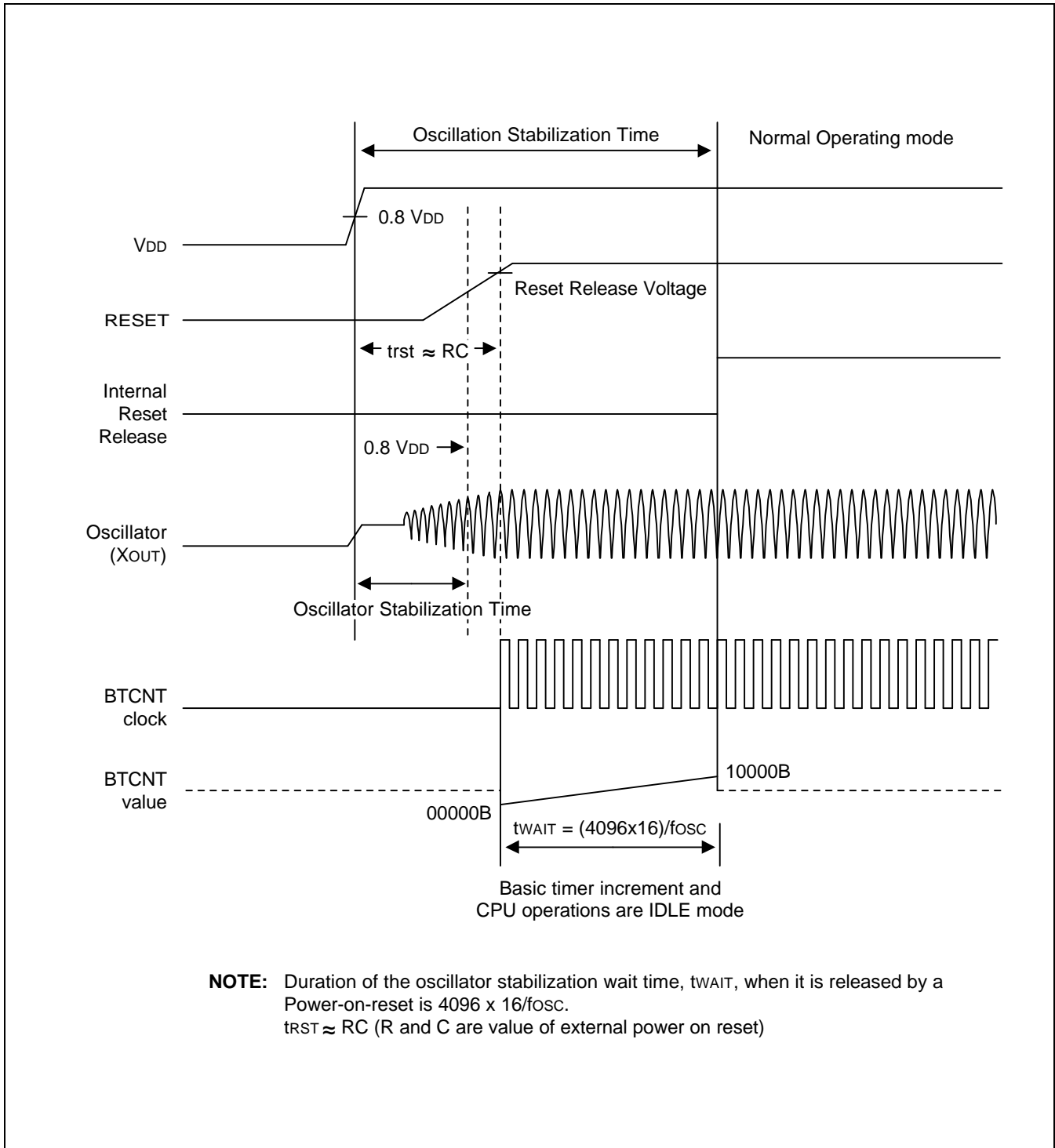


Figure 10-2. Oscillation Stabilization Time on RESET

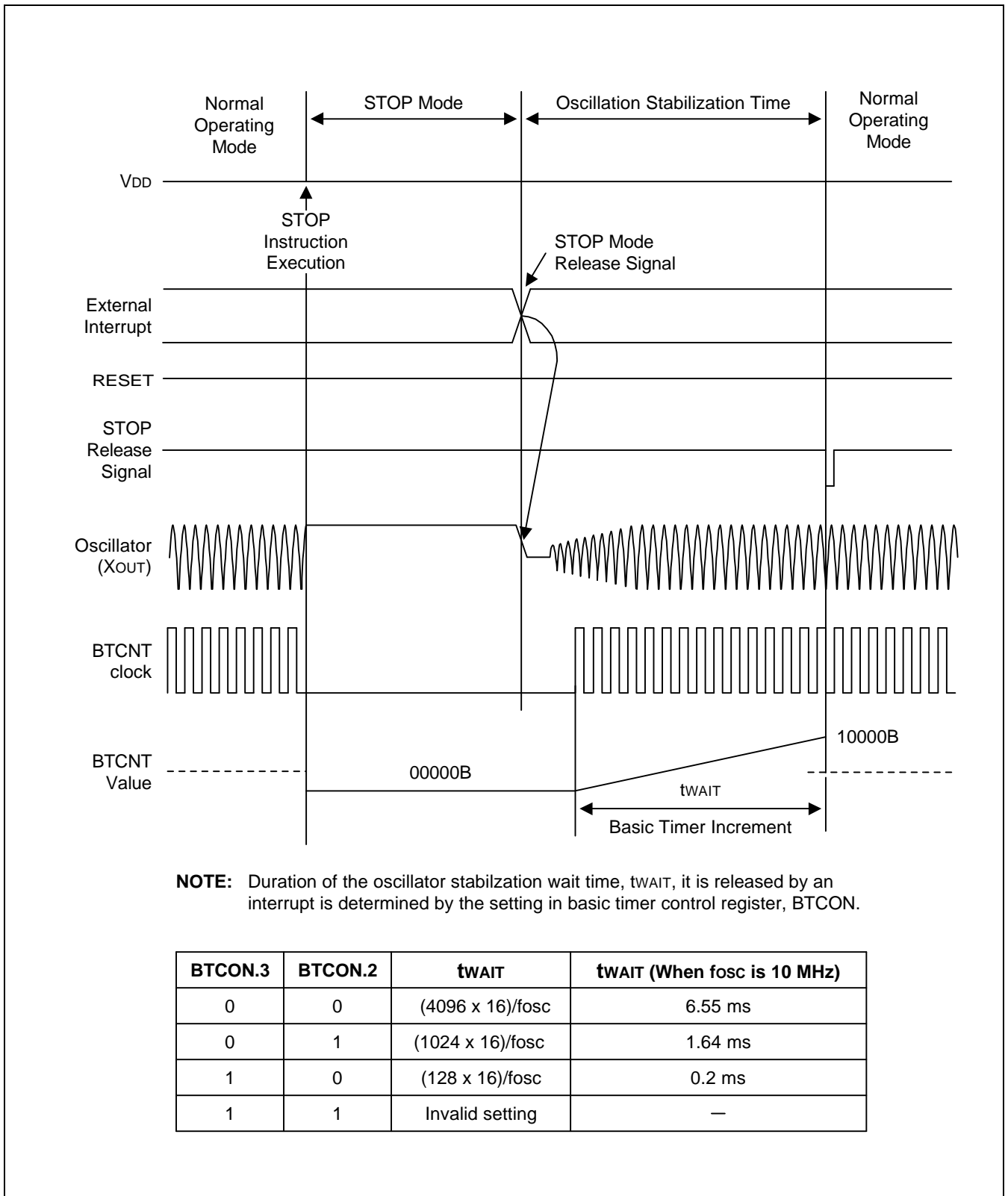


Figure 10-3. Oscillation Stabilization Time on STOP Mode Release

PROGRAMMING TIP — Configuring the Basic Timer

This example shows how to configure the basic timer to sample specification.

```

    ORG      0000H
    VECTOR   00H,INT_9454      ; S3C9454 has only one interrupt vector

;-----<< Smart Option >>

    ORG      003CH
    DB       00H               ; 003CH, must be initialized to 0
    DB       00H               ; 003DH, must be initialized to 0
    DB       0E7H              ; 003EH, enable LVR (2.3 V)
    DB       03H               ; 003FH, internal RC (3.2 MHz in VDD = 5 V)

;-----<< Initialize System and Peripherals >>

    ORG      0100H

RESET:   DI                   ; Disable interrupt
         LD      CLKCON,#00011000B ; Select non-divided CPU clock
         LD      SP,#0C0H       ; Stack pointer must be set
         .
         .

         LD      BTCON,#02H     ; Enable watchdog function
                                   ; Basic timer clock: fOSC/4096
                                   ; Basic counter (BTCNT) clear
         .
         .
         .
         EI                   ; Enable interrupt

;-----<< Main loop >>

MAIN:    .
         LD      BTCON,#02H     ; Enable watchdog function
                                   ; Basic counter (BTCNT) clear
         .
         .
         .
         JR      T,MAIN        ;

;-----<< Interrupt Service Routines >>

INT_9454: .
          .
          .
          .
          IRET
          .
          .
          END

```


TIMER 0

TIMER 0 CONTROL REGISTERS (T0CON)

The timer 0 control register, T0CON, is used to select the timer 0 operating mode (interval timer) and input clock frequency, to clear the timer 0 counter, and to enable the T0 match interrupt. It also contains a pending bit for T0 match interrupts.

A reset clears T0CON to "00H". This sets timer 0 to normal interval timer mode, selects an input clock frequency of $f_{OSC} / 4096$, and disables the T0 match interrupts. The T0 counter can be cleared at any time during normal operation by writing a "1" to T0CON.3.

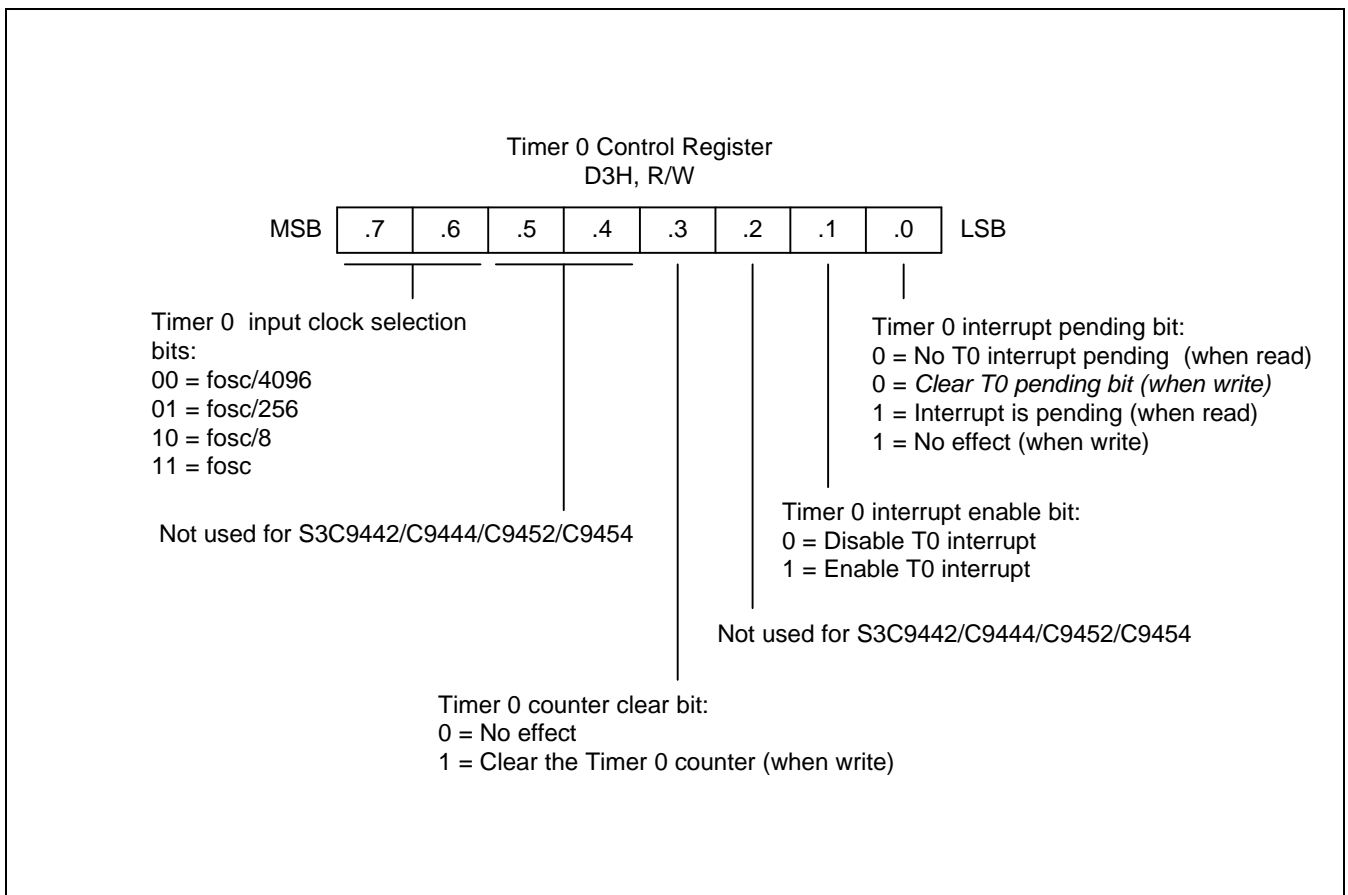


Figure 10-4. Timer 0 Control Registers (T0CON)

TIMER 0 FUNCTION DESCRIPTION

Interval Timer Mode

In interval timer mode, a match signal is generated when the counter value is identical to the value written to the Timer 0 reference data register, T0DATA. The match signal generates a Timer 0 match interrupt (T0INT, vector 00H) and then clears the counter. If, for example, you write the value "10H" to T0DATA, the counter will increment until it reaches "10H". At this point, the Timer 0 interrupt request is generated, the counter value is reset and counting resumes.

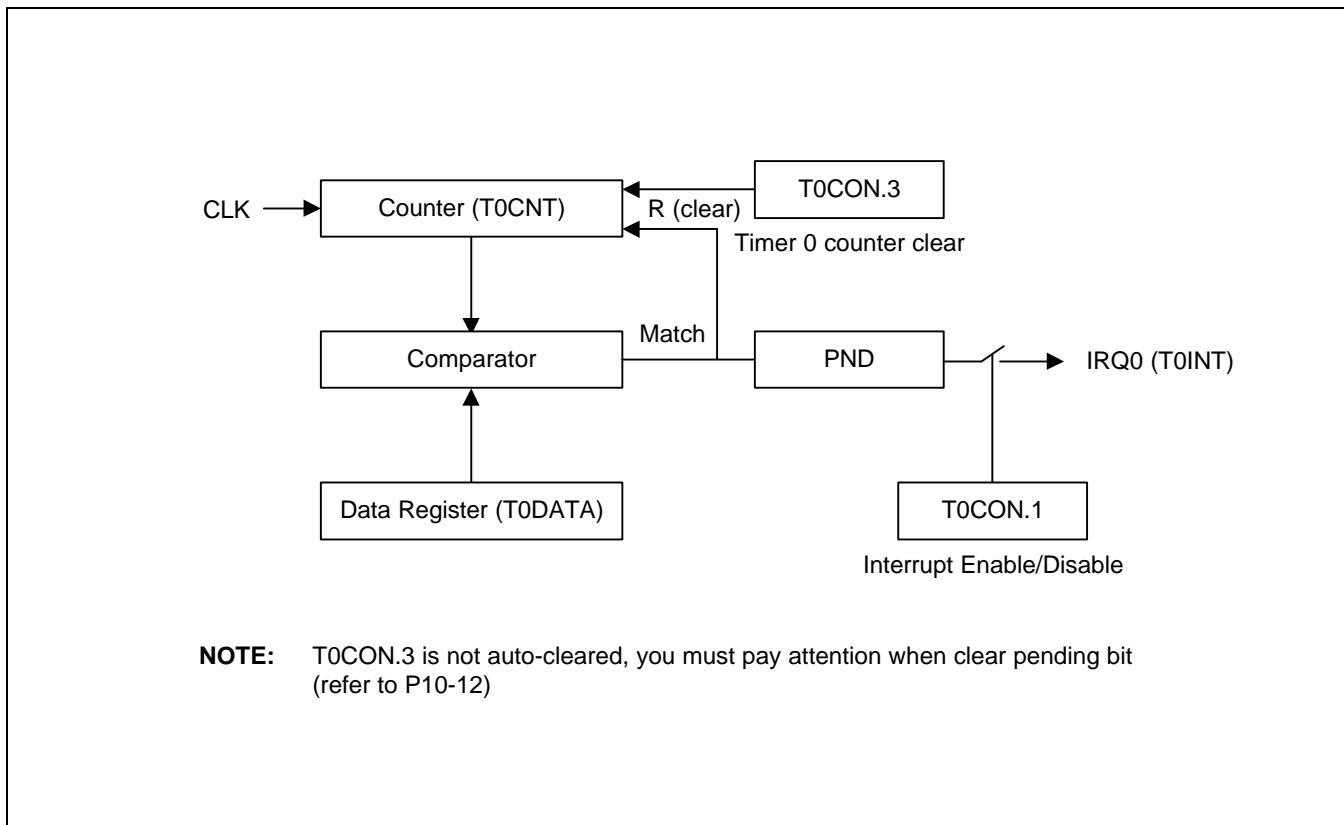


Figure 10-5. Simplified Timer 0 Function Diagram (Interval Timer Mode)

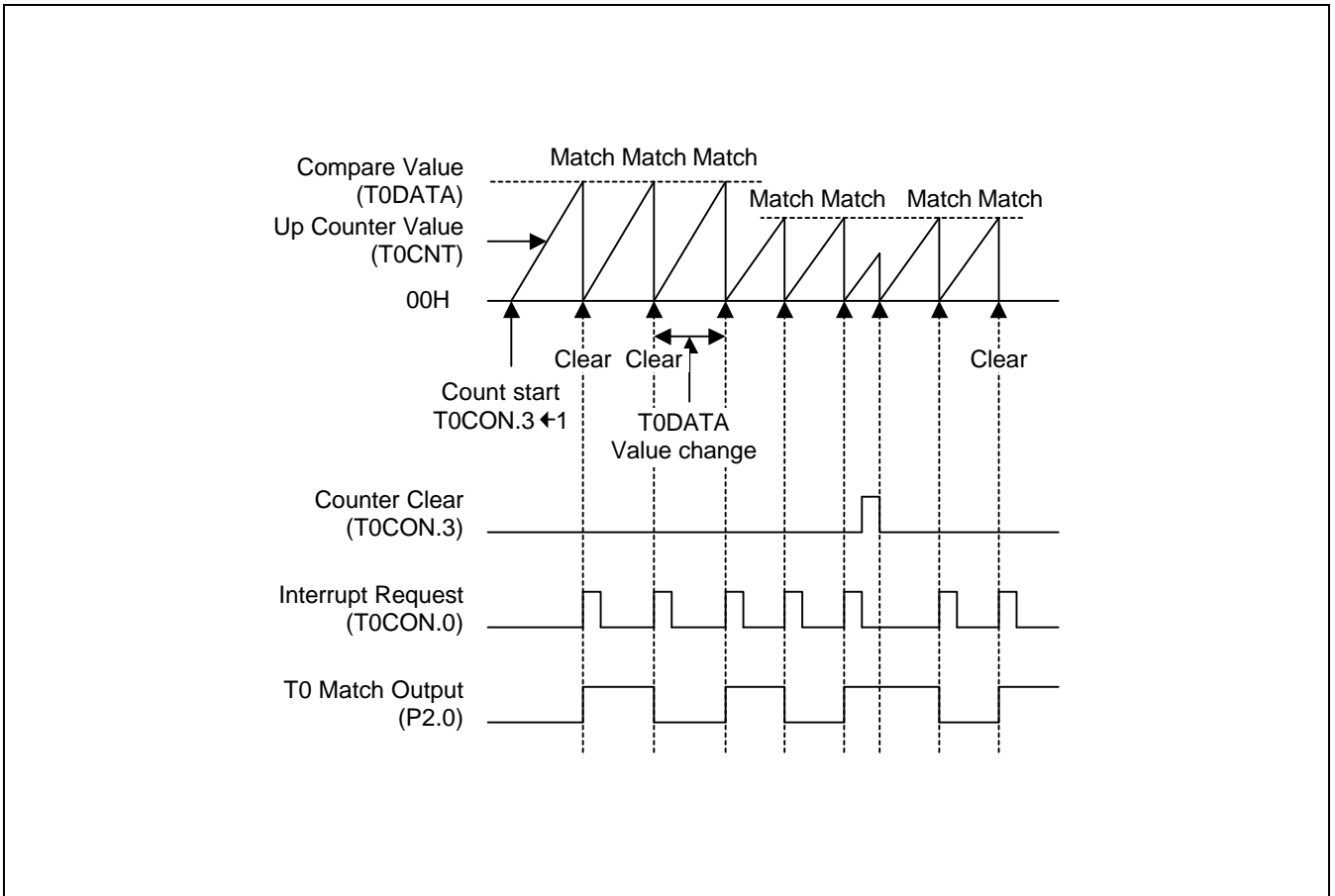


Figure 10-6. Timer 0 Timing Diagram

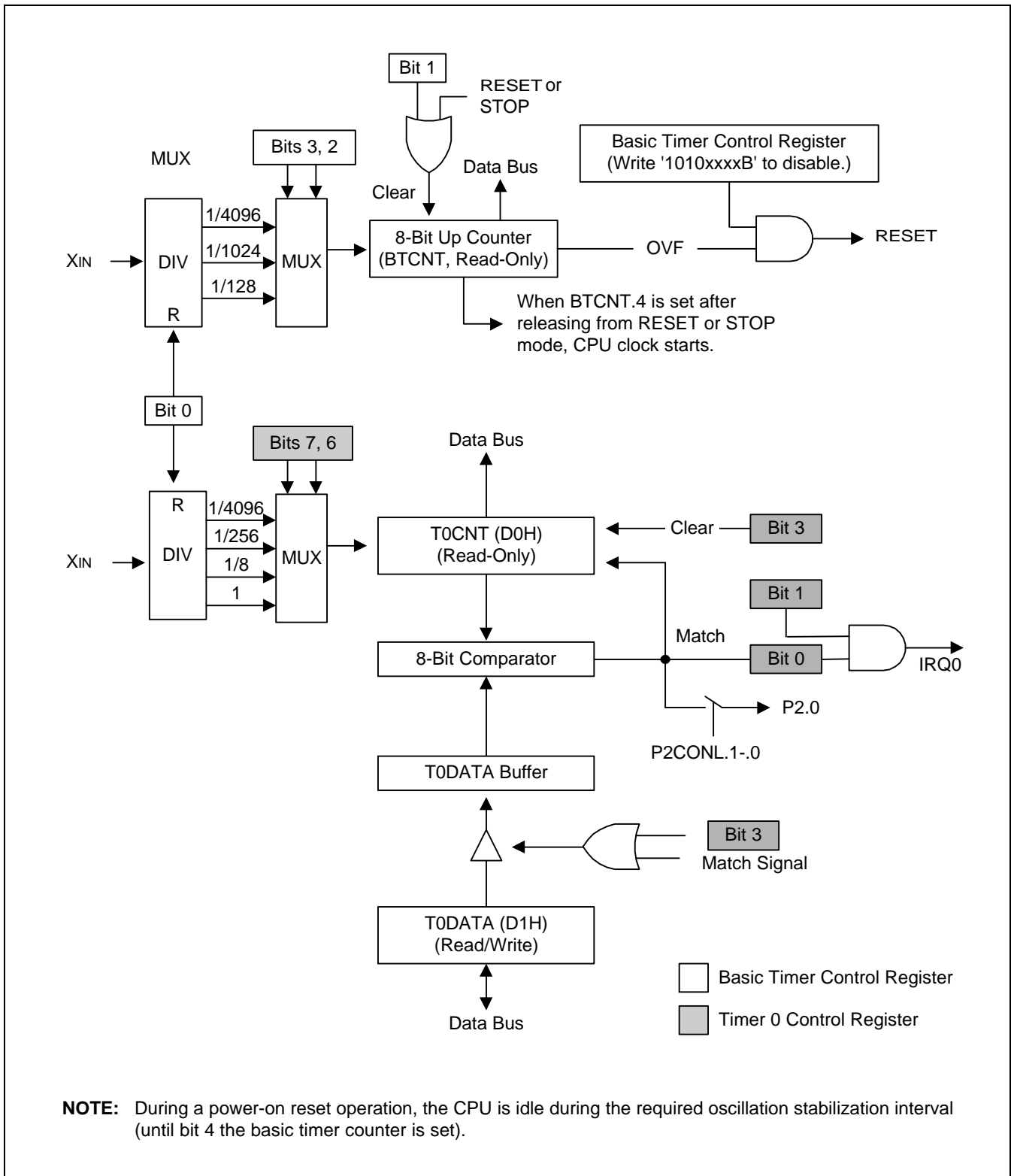


Figure 10-7. Basic Timer and Timer 0 Block Diagram

PROGRAMMING TIP1 – Configuring Timer 0 (Interval Mode)

The following sample program sets Timer 0 to interval timer mode.

```

        ORG      0000H
        VECTOR   00H,INT_9454      ; S3C9454 has only one interrupt vector

        ORG      003CH
        DB       00H                ; 003CH, must be initialized to 0
        DB       00H                ; 003DH, must be initialized to 0
        DB       0E7H               ; 003EH, enable LVR (2.3 V)
        DB       03H                ; 003FH, internal RC (3.2 MHz in VDD = 5 V)

        ORG      0100H

RESET:   DI                ; Disable interrupt
        LD       BTCON,#10100011B  ; Watchdog disable
        LD       CLKCON,#00011000B ; Select non-divided CPU clock
        LD       SP,#0C0H          ; Set stack pointer
        LD       P0CONH,#10101010B ;
        LD       P0CONL,#10101010B ; P0.0–0.7 push-pull output
        LD       P1CON,#00001010B  ; P1.0–P1.1 push-pull output
        LD       P2CONH,#01001010B ;
        LD       P2CONL,#10101010B ; P2.0–P2.6 push-pull output

;-----<< Timer 0 settings >>

        LD       T0DATA,#50H       ; CPU = 11.0592 MHz, interrupt interval = 2 msec
        LD       T0CON,#01001010B  ; fOSC/256, Timer0 interrupt enable
        .
        .
        .
        EI                ; Enable interrupt

;-----<< Main loop >>

MAIN:    NOP                ; Start main loop
        .
        .
        .
        CALL     LED_DISPLAY      ; Sub-block module
        .
        .
        .
        CALL     JOB              ; Sub-block module
        .
        .
        .
        JR       T,MAIN          ;

```

 **PROGRAMMING TIP1 – Configuring Timer 0 (Interval Mode) (Continued)**

```

LED_DISPLAY:  NOP                ;
              .                  ;
              .                  ;
              .                  ;
              RET                 ;

JOB:          NOP                ;
              .                  ;
              .                  ;
              .                  ;
              RET                 ;

;-----<< Interrupt Service Routines >>

INT_9454:     TM      T0CON,#00000010B ; Interrupt enable check
              JR      Z,NEXT_CHK1     ;

              TM      T0CON,#00000001B ; If timer 0 interrupt was occurred,
              JP      NZ,INT_TIMER0   ; T0CON.0 bit would be set.

NEXT_CHK1:   .                  ; Interrupt enable bit and pending bit check
              .                  ;
              .                  ;
              IRET                ;

INT_TIMER0:  .                  ; Timer 0 interrupt service routine
              .                  ;
              .                  ;
              AND     T0CON,#11110110B ; Pending bit clear
              IRET                ;
              .                  ;
              .                  ;
              END                  ;

```

11

8-BIT PWM (PULSE WIDTH MODULATION)

OVERVIEW

This microcontroller has the 8-bit PWM circuit. The operation of all PWM circuit is controlled by a single control register, PWMCON.

The PWM counter is a 8-bit incrementing counter. It is used by the 8-bit PWM circuits. To start the counter and enable the PWM circuits, you set PWMCON.2 to "1". If the counter is stopped, it retains its current count value; when re-started, it resumes counting from the retained count value. When there is a need to clear the counter you set PWMCON.3 to "1".

You can select a clock for the PWM counter by set PWMCON.6–.7. Clocks which you can select are $f_{OSC}/64$, $f_{OSC}/8$, $f_{OSC}/2$, $f_{OSC}/1$.

FUNCTION DESCRIPTION

PWM

The 8-bit PWM circuits have the following components:

- 6-bit comparator and extension cycle circuit
- 6-bit reference data register (PWMDATA.7–.2)
- 2-bit extension data register (PWMDATA.1–.0)
- PWM output pins (P0.6/PWM)

PWM counter

To determine the PWM module's base operating frequency, the upper 6-bits of counter is compared to the PWM data (PWMDATA.7–.2). In order to achieve higher resolutions, the lower 2-bits of the counter can be used to modulate the "stretch" cycle. To control the "stretching" of the PWM output duty cycle at specific intervals, the lower 2-bits of counter value is compared with the PWMDATA.1–.0.

PWM data and extension registers

PWM (duty) data registers, located in F2H, determine the output value generated by each 8-bit PWM circuit.

To program the required PWM output, you load the appropriate initialization values into the 6-bit reference data register (PWMDATA.7–.2) and the 2-bit extension data register (PWMDATA.1–.0). To start the PWM counter, or to resume counting, you set PWMCON.2 to "1".

A reset operation disables all PWM output. The current counter value is retained when the counter stops. When the counter starts, counting resumes at the retained value.

PWM clock rate

The timing characteristics of PWM output is based on the f_{OSC} clock frequency. The PWM counter clock value is determined by the setting of PWMCON.6–.7.

Table 11-1. PWM Control and Data Registers

Register Name	Mnemonic	Address	Function
PWM data registers	PWMDATA.7–.2	F2H.7–.2	6-bit PWM basic cycle frame value
	PWMDATA.1–.0	F2H.1–.0	2-bit extension ("stretch") value
PWM control registers	PWMCON	F3H	PWM counter stop/start (resume), and PWM counter clock settings

PWM function Description

The PWM output signal toggles to Low level whenever the lower 6-bit of counter matches the reference data register (PWMDATA.7–.2). If the value in the PWMDATA.7–.2 register is not zero, an overflow of the lower 6-bits of counter causes the PWM output to toggle to High level. In this way, the reference value written to the reference data register determines the module's base duty cycle.

The value in the upper 2-bits of counter is compared with the extension settings in the 2-bit extension data register (PWMDATA.1–.0). This lower 2-bits of counter value, together with extension logic and the PWM module's extension data register, is then used to "stretch" the duty cycle of the PWM output. The "stretch" value is one extra clock period at specific intervals, or cycles (see Table 11-2).

If, for example, the value in the extension data register is '01B', the 2nd cycle will be one pulse longer than the other 3 cycles. If the base duty cycle is 50 %, the duty of the 2nd cycle will therefore be "stretched" to approximately 51% duty. For example, if you write 10B to the extension data register, all odd-numbered pulses will be one cycle longer. If you write 11H to the extension data register, all pulses will be stretched by one cycle except the 4th pulse. PWM output goes to an output buffer and then to the corresponding PWM output pin. In this way, you can obtain high output resolution at high frequencies.

Table 11-2. PWM output "stretch" Values for Extension Data Register (PWMDATA.1-0)

PWMDATA Bit (Bit1-Bit0)	"Stretched" Cycle Number
00	-
01	2
10	1, 3
11	1, 2, 3

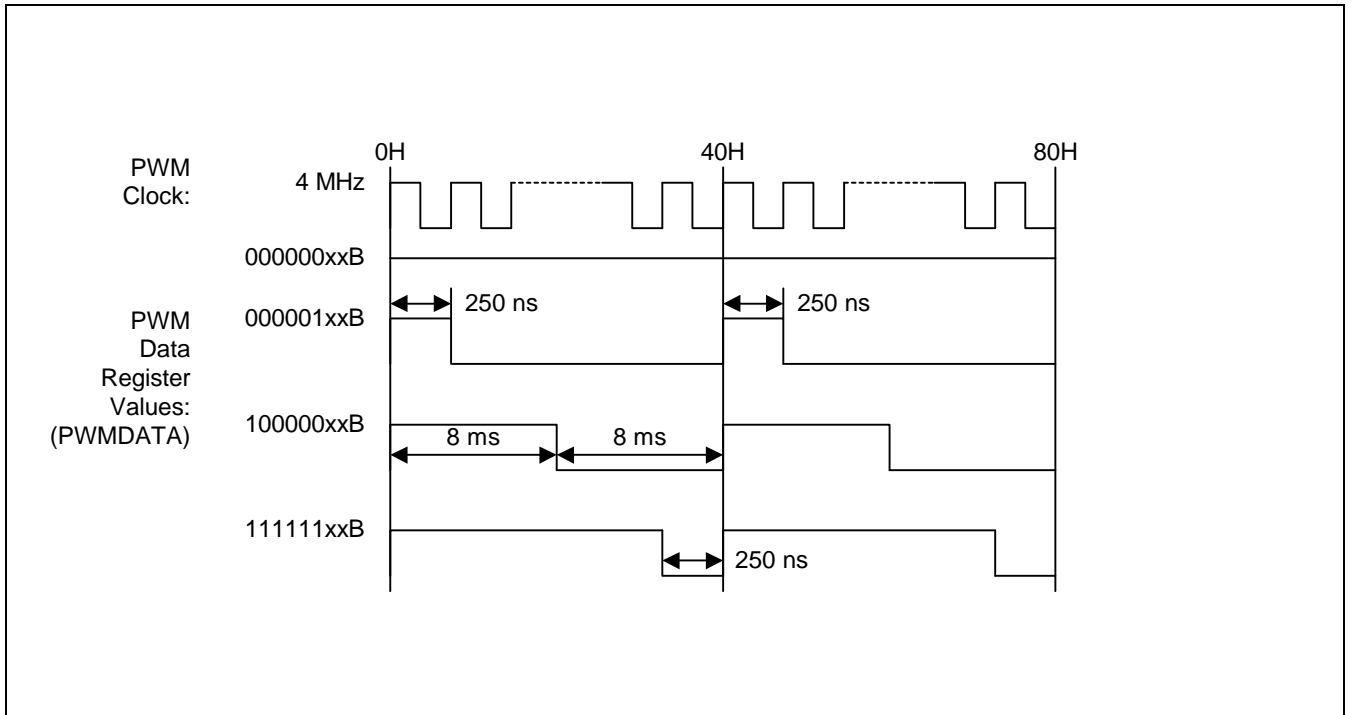


Figure 11-1. 8-Bit PWM Basic Waveform

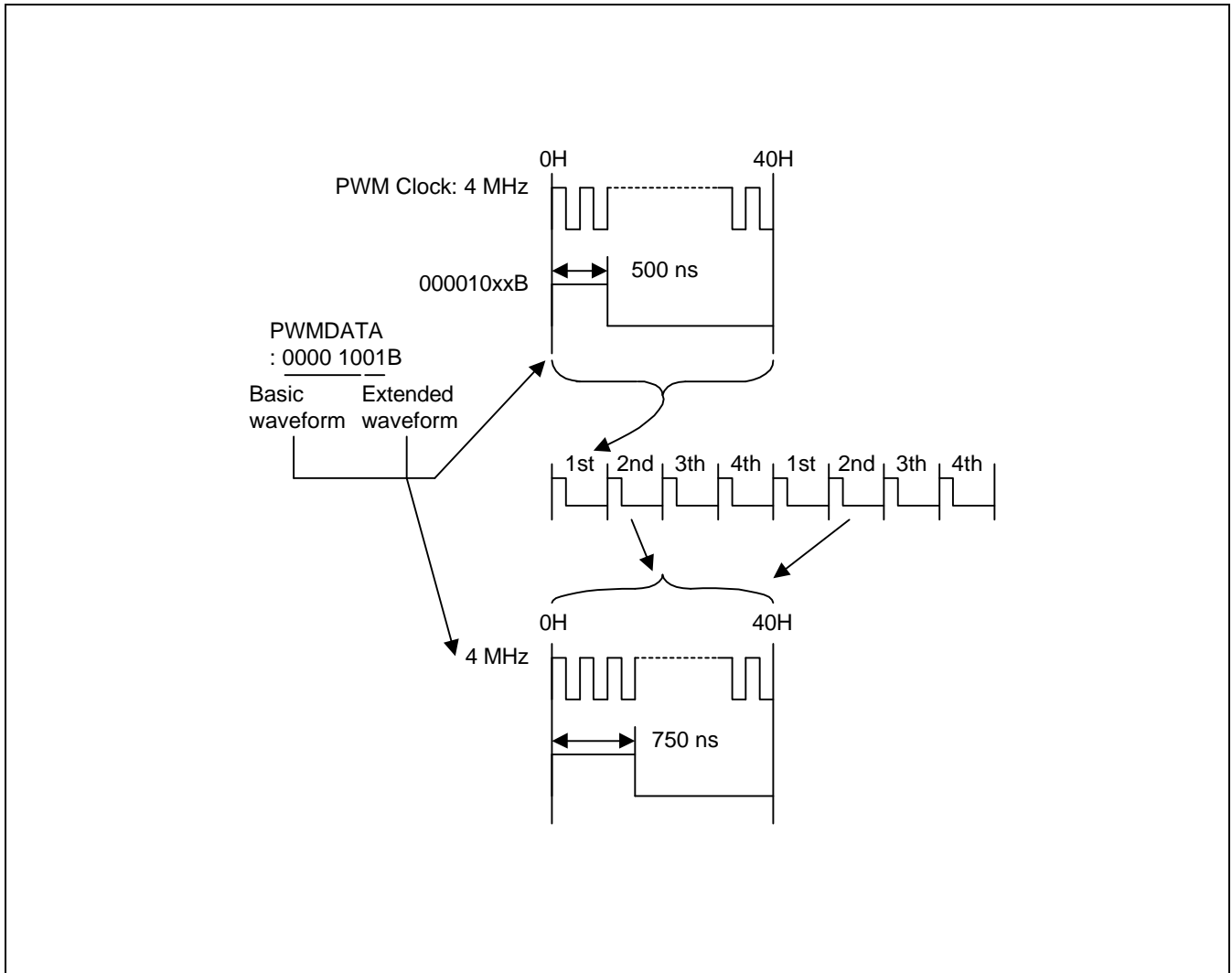


Figure 11-2. 8-Bit Extended PWM Waveform

PWM CONTROL REGISTER (PWMCON)

The control register for the PWM module, PWMCON, is located at register address F3H. PWMCON is used the 8-bit PWM modules. Bit settings in the PWMCON register control the following functions:

- PWM counter clock selection
- PWM data reload interval selection
- PWM counter clear
- PWM counter stop/start (or resume) operation
- PWM counter overflow (8-bit counter overflow) interrupt control

A reset clears all PWMCON bits to logic zero, disabling the entire PWM module.

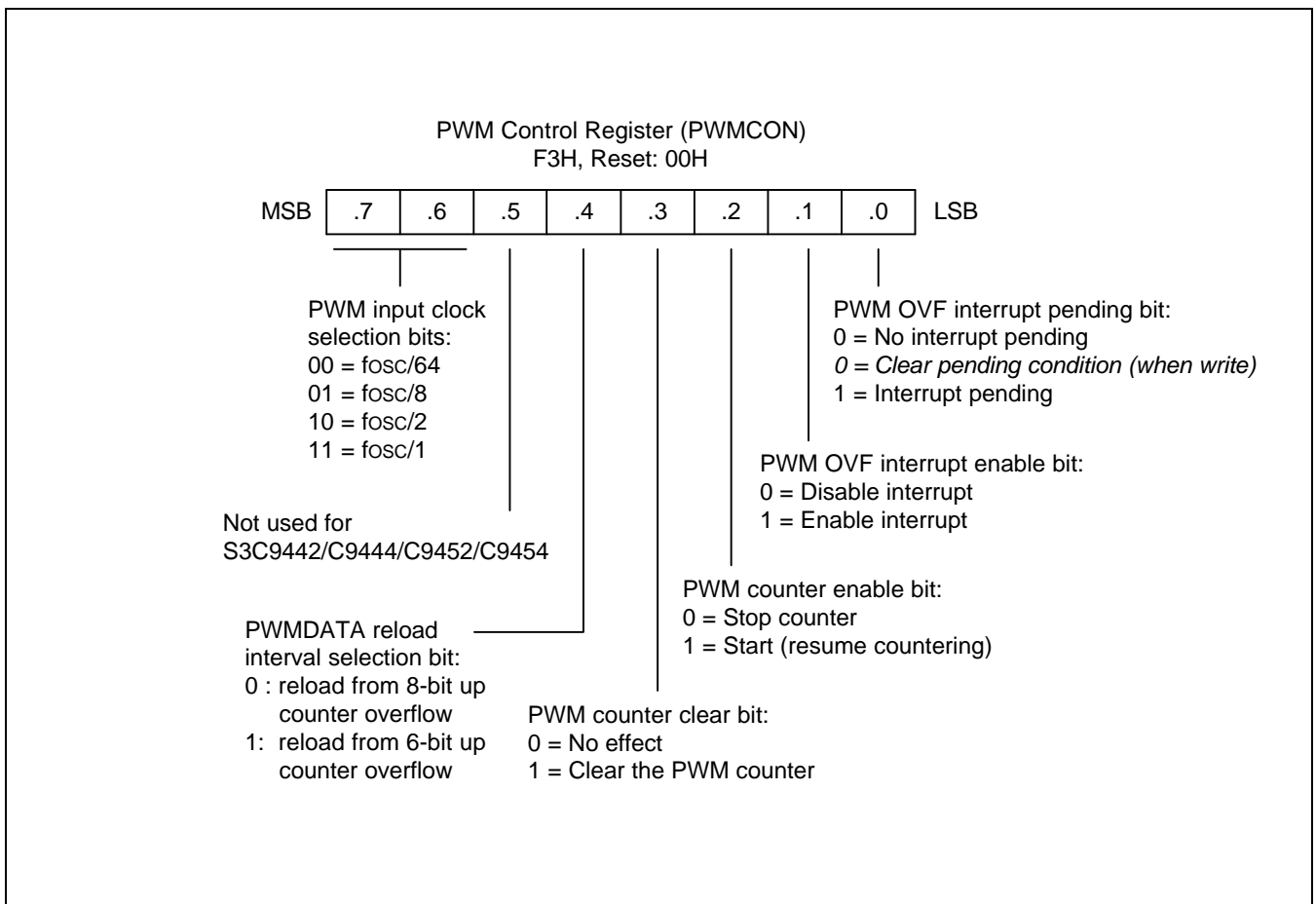


Figure 11-3. PWM Control Register (PWMCON)

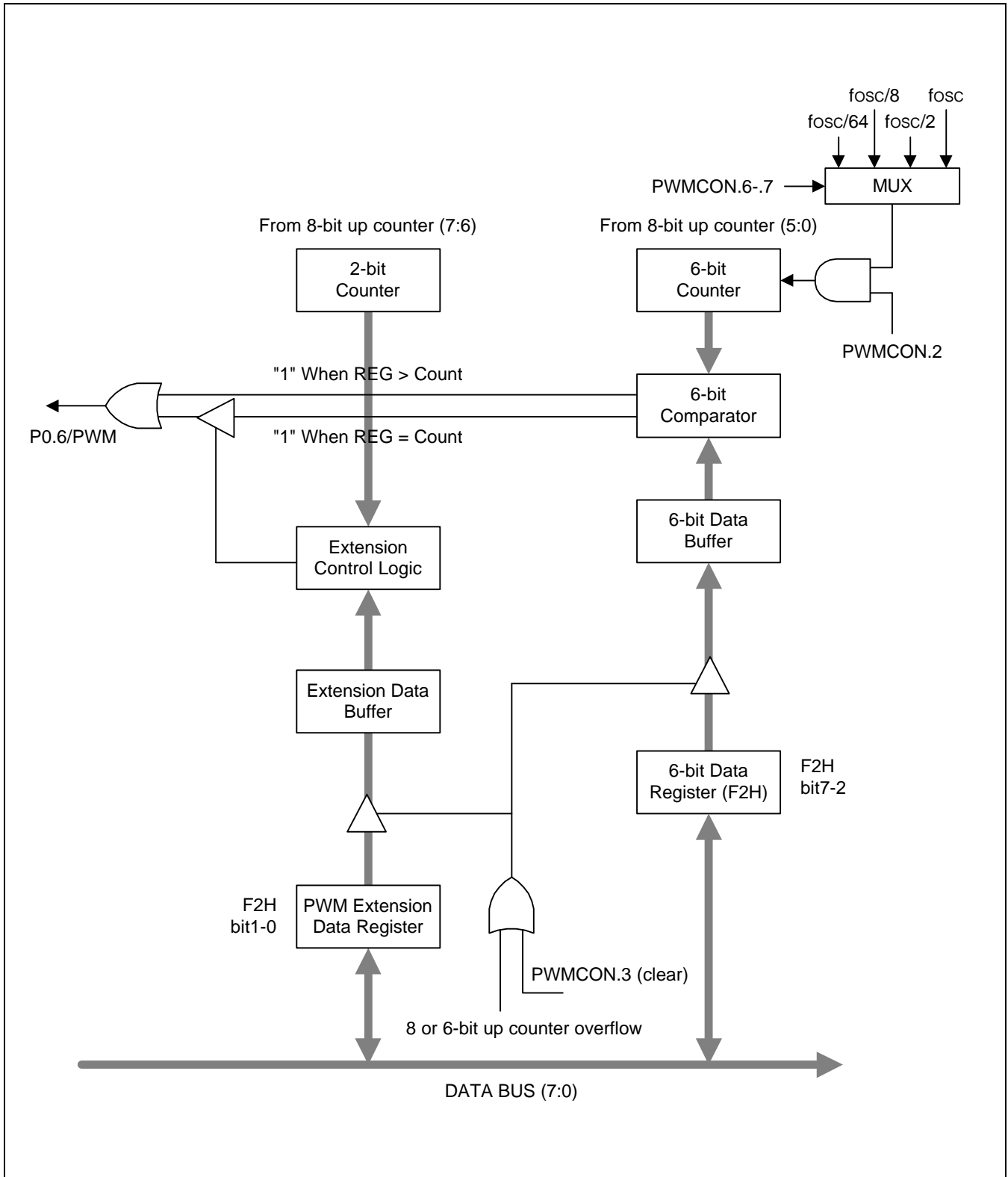


Figure 11-4. PWM Functional Block Diagram

 **PROGRAMMING TIP — Programming the PWM Module to Sample Specifications**

;-----<< Interrupt Vector Address >>

```
ORG      0000H
          VECTOR    00H,INT_9454      ; S3C9454 has only one interrupt vector
```

;-----<< Smart Option >>

```
ORG      003CH
          DB        00H                ; 003CH, must be initialized to 0.
          DB        00H                ; 003DH, must be initialized to 0.
          DB        0E7H               ; 003EH, enable LVR (2.3 V)
          DB        03H                ; 003FH, internal RC (3.2 MHz in VDD = 5 V)
```

;-----<< Initialize System and Peripherals >>

```
RESET:    ORG      0100H
          DI        ; disable interrupt
          LD        BTCON,#10100011B ; Watchdog disable
          .
          .
          LD        P0CONH,#10011010B ; Configure P0.6 PWM output
          LD        PWMCON,#00000110B ; fOSC/64, counter/interrupt enable
          LD        PWMDATA,#80H      ;
          .
          .
          EI        ; Enable interrupt
```

;-----<< Main loop >>

```
MAIN:     ;
          .
          .
          .
          .
          JR        t,MAIN            ;
```

;-----<< Interrupt Service Routines >>

```
INT_9454: .
          TM        PWMCON,#00000010B ; Interrupt enable bit and pending bit check
          ; Interrupt enable check
          JR        Z,NEXT_CHK1        ;
          TM        PWMCON,#00000001B ; Interrupt pending bit check
          JP        NZ,INT_PWM         ; PWMCON's pending bit set --> PWM interrupt
```

```
NEXT_CHK1: .
          .
          .
          IRET        ;
```

 **PROGRAMMING TIP — Programming the PWM Module to Sample Specifications (Continued)**

```
INT_PWM:                                ; PWM interrupt service routine
    .
    .
    .
    AND     PWMCON,#11110110B    ; pending bit clear
    IRET                                ;
    .
    .
    END
```

12

A/D CONVERTER

OVERVIEW

The 10-bit A/D converter (ADC) module uses successive approximation logic to convert analog levels entering at one of the nine input channels to equivalent 10-bit digital values. The analog input level must lie between the V_{DD} and V_{SS} values. The A/D converter has the following components:

- Analog comparator with successive approximation logic
- D/A converter logic
- ADC control register (ADCON)
- Nine multiplexed analog data input pins (ADC0–ADC8)
- 10-bit A/D conversion data output register (ADDATAH/L):

To initiate an analog-to-digital conversion procedure, you write the channel selection data in the A/D converter control register ADCON to select one of the nine analog input pins (ADC n , $n = 0-8$) and set the conversion start or enable bit, ADCON.0. The read-write ADCON register is located at address F7H.

During a normal conversion, ADC logic initially sets the successive approximation register to 200H (the approximate half-way point of an 10-bit register). This register is then updated automatically during each conversion step. The successive approximation block performs 10-bit conversions for one input channel at a time. You can dynamically select different channels by manipulating the channel selection bit value (ADCON.7–4) in the ADCON register. To start the A/D conversion, you should set the enable bit, ADCON.0. When a conversion is completed, ADCON.3, the end-of-conversion (EOC) bit is automatically set to 1 and the result is dumped into the ADDATA register where it can be read. The A/D converter then enters an idle state. Remember to read the contents of ADDATA before another conversion starts. Otherwise, the previous result will be overwritten by the next conversion result.

NOTE

Because the ADC does not use sample-and-hold circuitry, it is important that any fluctuations in the analog level at the ADC0–ADC8 input pins during a conversion procedure be kept to an absolute minimum. Any change in the input level, perhaps due to circuit noise, will invalidate the result.

USING A/D PINS FOR STANDARD DIGITAL INPUT

The ADC module's input pins are alternatively used as digital input in port 0 and P2.6.

A/D CONVERTER CONTROL REGISTER (ADCON)

The A/D converter control register, ADCON, is located at address F7H. ADCON has four functions:

- Bits 7-4 select an analog input pin (ADC0–ADC8).
- Bit 3 indicates the status of the A/D conversion.
- Bits 2-1 select a conversion speed.
- Bit 0 starts the A/D conversion.

Only one analog input channel can be selected at a time. You can dynamically select any one of the ten analog input pins (ADC0–ADC8) by manipulating the 4-bit value for ADCON.7–ADCON.4.

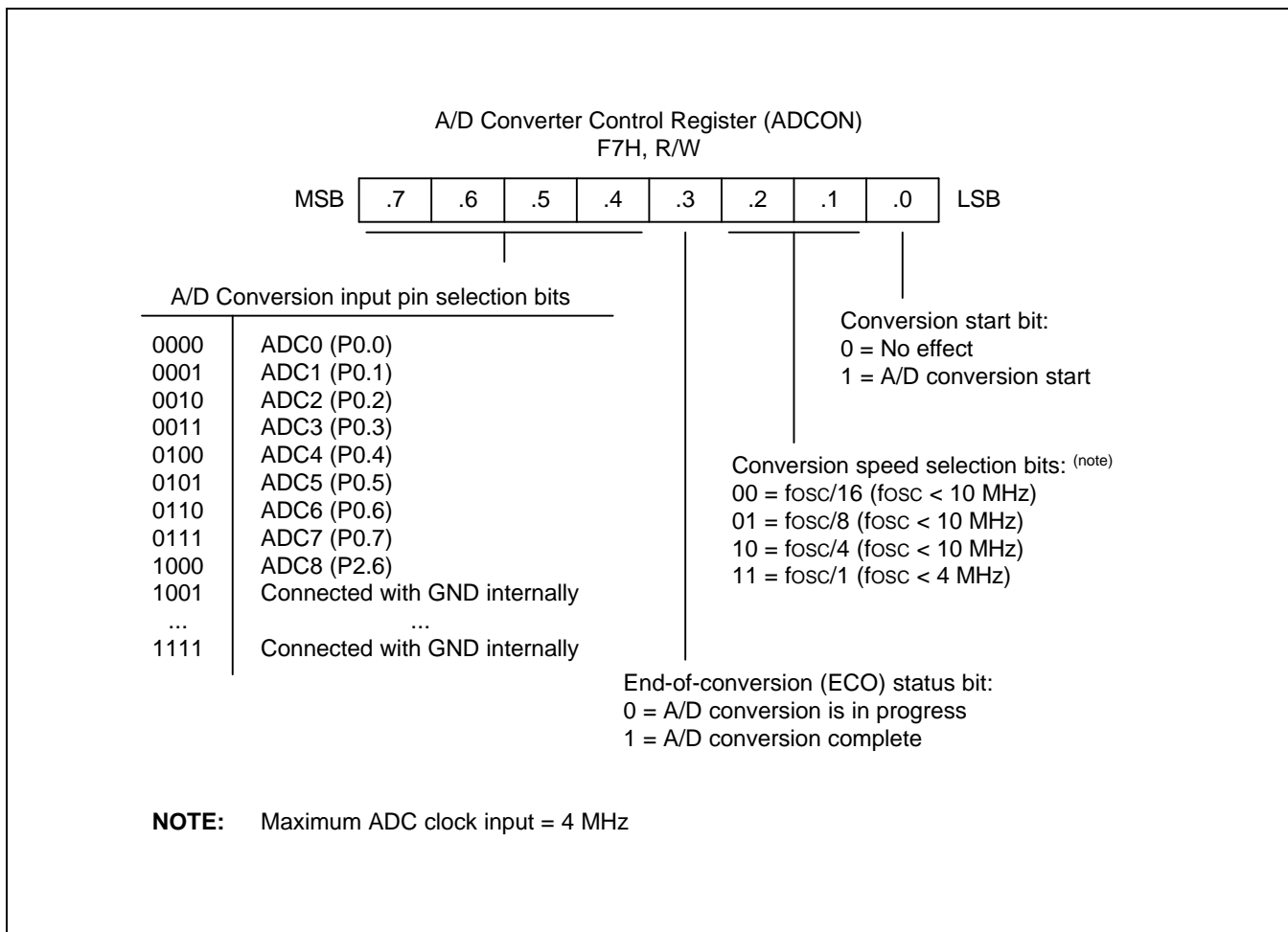


Figure 12-1. A/D Converter Control Register (ADCON)

INTERNAL REFERENCE VOLTAGE LEVELS

In the ADC function block, the analog input voltage level is compared to the reference voltage. The analog input level must remain within the range V_{SS} to V_{DD} .

Different reference voltage levels are generated internally along the resistor tree during the analog conversion process for each conversion step. The reference voltage level for the first bit conversion is always $1/2 V_{DD}$.

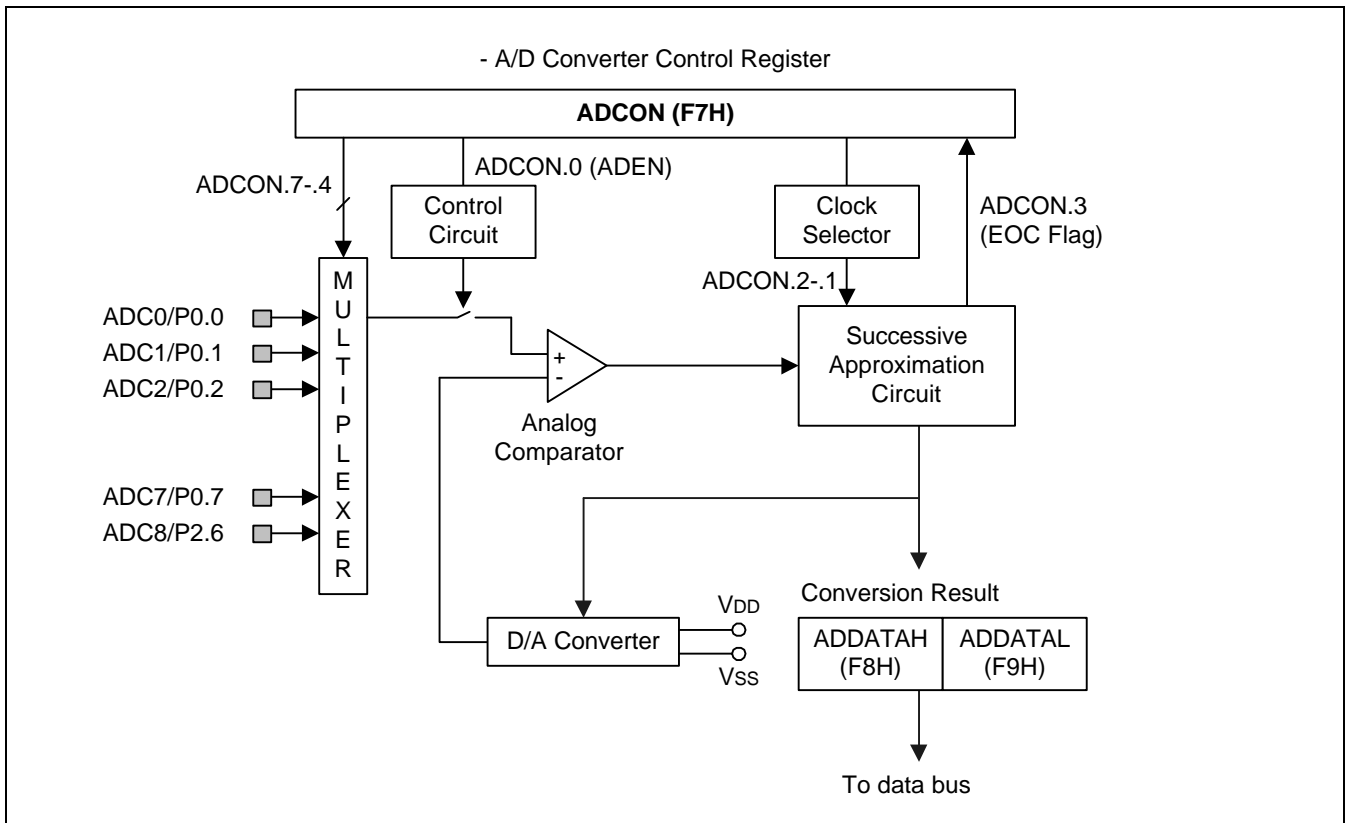


Figure 12-2. A/D Converter Circuit Diagram

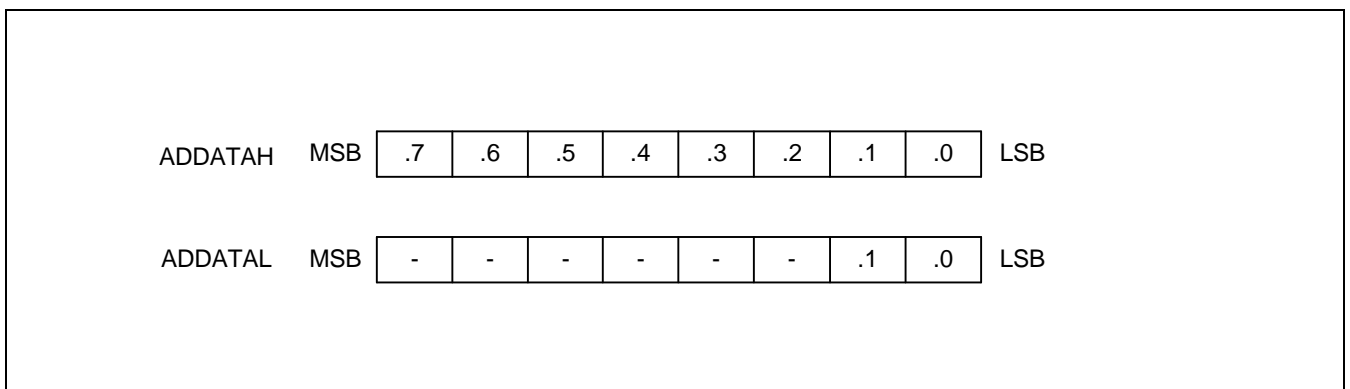


Figure 12-3. A/D Converter Data Register (ADDATAH/L)

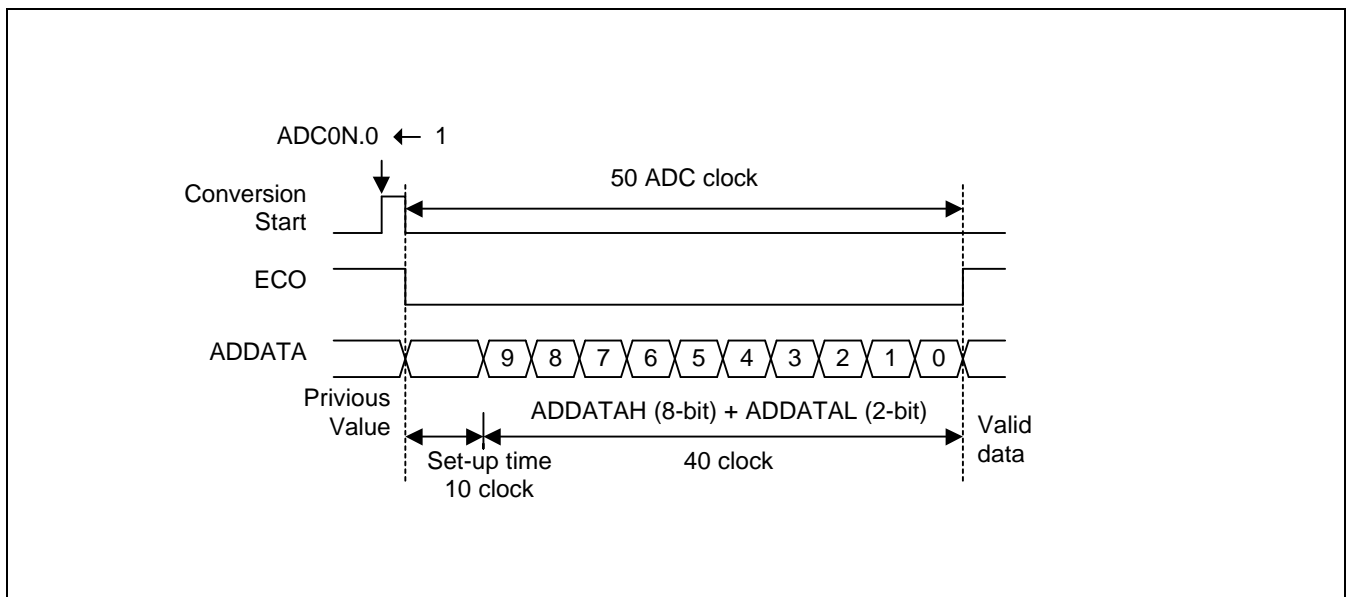


Figure 12-4. A/D Converter Timing Diagram

CONVERSION TIMING

The A/D conversion process requires 4 steps (4 clock edges) to convert each bit and 10 clocks to step-up A/D conversion. Therefore, total of 50 clocks are required to complete an 10-bit conversion: With an 10 MHz CPU clock frequency, one clock cycle is 400 ns ($4/f_{OSC}$). If each bit conversion requires 4 clocks, the conversion rate is calculated as follows:

$$4 \text{ clocks/bit} \times 10\text{-bits} + \text{step-up time (10 clock)} = 50 \text{ clocks}$$

$$50 \text{ clock} \times 400 \text{ ns} = 20 \mu\text{s at 10 MHz, 1 clock time} = 4/f_{OSC} \text{ (assuming } ADCON.2-1 = 10)$$

INTERNAL A/D CONVERSION PROCEDURE

1. Analog input must remain between the voltage range of V_{SS} and V_{DD} .
2. Configure the analog input pins to input mode by making the appropriate settings in P0CONH, P0CONL and P2CONH registers.
3. Before the conversion operation starts, you must first select one of the nine input pins (ADC0–ADC8) by writing the appropriate value to the ADCON register.
4. When conversion has been completed, (50 clocks have elapsed), the EOC flag is set to “1”, so that a check can be made to verify that the conversion was successful.
5. The converted digital value is loaded to the output register, ADDATAH (8-bit) and ADDATAL (2-bit), then the ADC module enters an idle state.
6. The digital conversion result can now be read from the ADDATAH and ADDATAL register.

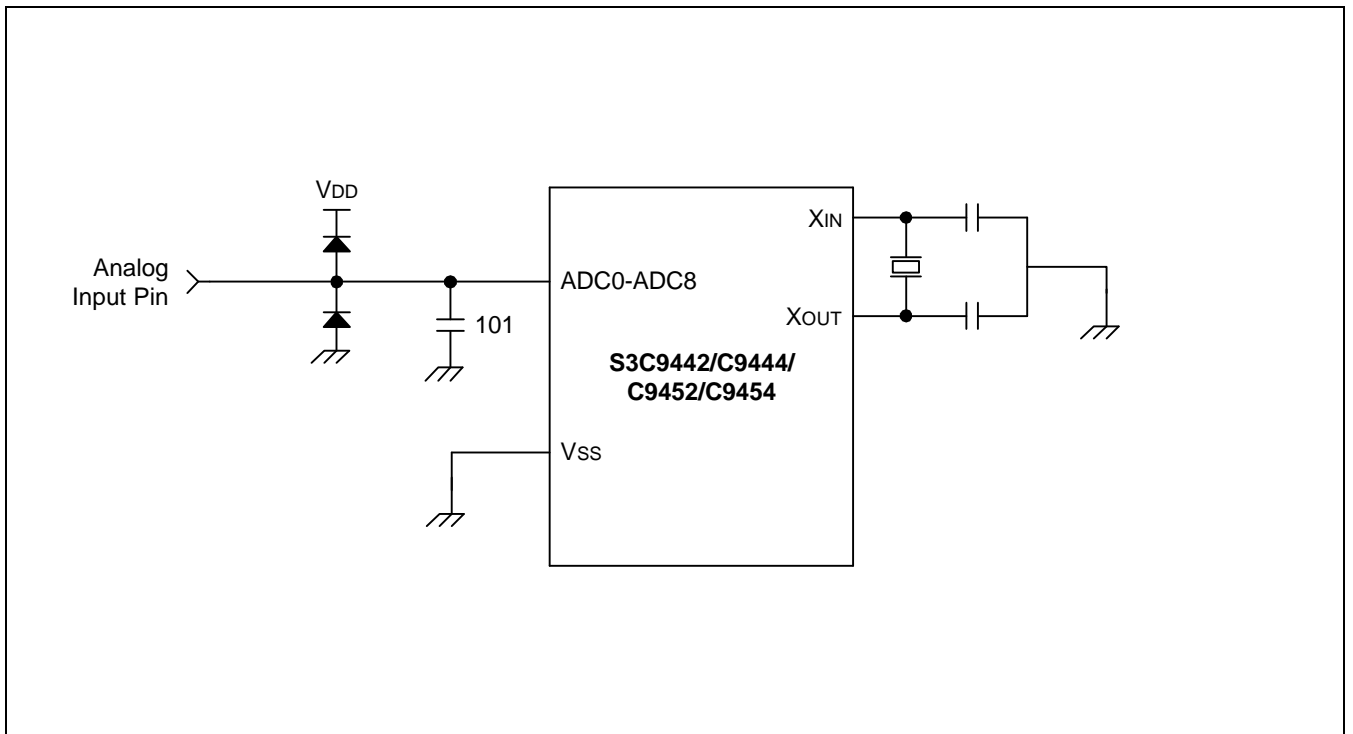


Figure 12-5. Recommended A/D Converter Circuit for Highest Absolute Accuracy

 **Programming Tip– Configuring A/D Converter**

```

        ORG    0000H
        VECTOR 00H,INT_9454      ; S3C9454 has only one interrupt vector

ORG     003CH
        DB     00H                ; 003CH, must be initialized to 0
        DB     00H                ; 003DH, must be initialized to 0
        DB     0E7H               ; 003EH, enable LVR (2.3 V)
        DB     03H                ; 003FH, internal RC (3.2 MHz in VDD = 5 V)

RESET:  ORG     0100H
        DI                    ; disable interrupt
        LD     BTCON,#10100011B ; Watchdog disable
        .
        .
        .
        LD     P0CONH,#11111111B ; Configure P0.4–P0.7 AD input
        LD     P0CONL,#11111111B ; Configure P0.0–P0.3 AD input
        LD     P2CONH,#00100000B ; Configure P2.6 AD input
        EI                    ; Enable interrupt

;-----<< Main loop >>

MAIN:   .
        .
        .
        CALL  AD_CONV          ; Subroutine for AD conversion
        .
        .
        .
        JR    t,MAIN           ;

AD_CONV: LD     ADCON,#00000001B ; Select analog input channel → P0.0
        ; select conversion speed → fOSC/16
        ; set conversion start bit

        NOP
        NOP                    ; If you select conversion speed to fOSC/16
        NOP                    ; at least three nop must be included

```

 **Programming Tip– Configuring A/D Converter (Continued)**

```

CONV_LOOP: TM      ADCON,#00001000B ; Check EOC flag
              JR      Z,CONV_LOOP   ; If EOC flag=0, jump to CONV_LOOP until EOC flag=1
              LD      R0,ADDATAH     ; High 8 bits of conversion result are stored
                                      ; to ADDATAH register

              LD      R1,ADDATAL     ; Low 2 bits of conversion result are stored
                                      ; to ADDATAL register
              LD      ADCON,#00010011B ; Select analog input channel → P0.1
                                      ; Select conversion speed → fOSC/8
                                      ; Set conversion start bit

CONV_LOOP2: TM   ADCON,#00001000B ; Check EOC flag
              JR      Z,CONV_LOOP2
              LD      R2,ADDATAH
              LD      R3,ADDATAL
              .
              .
              .
              RET
INT_9454:     . ;
              . ; Interrupt enable bit and pending bit check
              . ;
              . ; Pending bit clear
              IRET
              .
              .
              END

```

13

ELECTRICAL DATA

OVERVIEW

In this section, the following S3C9442/C9444/C9452/C9454 electrical characteristics are presented in tables and graphs:

- Absolute maximum ratings
- D.C. electrical characteristics
- A.C. electrical characteristics
- Input Timing Measurement Points
- Oscillator characteristics
- Oscillation stabilization time
- Operating Voltage Range
- Schmitt trigger input characteristics
- Data retention supply voltage in Stop mode
- Stop mode release timing when initiated by a RESET
- A/D converter electrical characteristics
- LVR circuit characteristics
- LVR reset Timing

Table 13-1. Absolute Maximum Ratings

 $(T_A = 25\text{ }^\circ\text{C})$

Parameter	Symbol	Conditions	Rating	Unit
Supply voltage	V_{DD}	–	– 0.3 to + 6.5	V
Input voltage	V_I	All ports	– 0.3 to $V_{DD} + 0.3$	V
Output voltage	V_O	All output ports	– 0.3 to $V_{DD} + 0.3$	V
Output current high	I_{OH}	One I/O pin active	– 25	mA
		All I/O pins active	– 80	
Output current low	I_{OL}	One I/O pin active	+ 30	mA
		All I/O pins active	+ 150	
Operating temperature	T_A	–	– 40 to + 85	$^\circ\text{C}$
Storage temperature	T_{STG}	–	– 65 to + 150	$^\circ\text{C}$

Table 13-2. DC Electrical Characteristics

 $(T_A = -40\text{ }^\circ\text{C to } +85\text{ }^\circ\text{C}, V_{DD} = 2.0\text{ V to } 5.5\text{ V})$

Parameter	Symbol	Conditions	Min	Typ	Max	Unit	
Input high voltage	V_{IH1}	Ports 0, 1, 2 and RESET	$V_{DD} = 2.0\text{ to } 5.5\text{ V}$	$0.8 V_{DD}$	-	V_{DD}	V
	V_{IH2}	X_{IN} and X_{OUT}		$V_{DD} - 0.1$			
Input low voltage	V_{IL1}	Ports 0, 1, 2 and RESET	$V_{DD} = 2.0\text{ to } 5.5\text{ V}$	-	-	$0.2 V_{DD}$	V
	V_{IL2}	X_{IN} and X_{OUT}				0.1	
Output high voltage	V_{OH}	$I_{OH} = -10\text{ mA}$ ports 0, 1, 2	$V_{DD} = 4.5\text{ to } 5.5\text{ V}$	$V_{DD} - 1.5$	$V_{DD} - 0.4$	-	V
Output low voltage	V_{OL}	$I_{OL} = 25\text{ mA}$ port 0, 1, and 2	$V_{DD} = 4.5\text{ to } 5.5\text{ V}$	-	0.4	2.0	V
Input high leakage current	I_{LIH1}	All input except I_{LIH2}	$V_{IN} = V_{DD}$	-	-	1	μA
	I_{LIH2}	X_{IN} , X_{OUT}	$V_{IN} = V_{DD}$	-	-	20	
Input low leakage current	I_{LIL1}	All input except I_{LIL2} and RESET	$V_{IN} = 0\text{ V}$	-	-	-1	μA
	I_{LIL2}	X_{IN} , X_{OUT}	$V_{IN} = 0\text{ V}$	-	-	-20	
Output high leakage current	I_{LOH}	All output pins	$V_{OUT} = V_{DD}$	-	-	2	μA
Output low leakage current	I_{LOL}	All output pins	$V_{OUT} = 0\text{ V}$	-	-	-2	μA
Pull-up resistors	R_P	$V_{IN} = 0\text{ V}$ Ports 0, 1, 2	$V_{DD} = 5\text{ V}$	25	50	100	k Ω
Pull-down resistors	R_P	$V_{IN} = 0\text{ V}$ Ports 1	$V_{DD} = 5\text{ V}$	25	50	100	
Supply current	I_{DD1}	Run mode 10 MHz CPU clock	$V_{DD} = 4.5\text{ to } 5.5\text{ V}$	-	5	10	mA
		3 MHz CPU clock	$V_{DD} = 2.0\text{ V}$			2	
	I_{DD2}	Idle mode 10 MHz CPU clock	$V_{DD} = 4.5\text{ to } 5.5\text{ V}$	-	2	4	
		3 MHz CPU clock	$V_{DD} = 2.0\text{ V}$			0.5	
	I_{DD3}	Stop mode	$V_{DD} = 4.5\text{ to } 5.5\text{ V}$ (LVR disable)	-	0.1	5	
			$V_{DD} = 4.5\text{ to } 5.5\text{ V}$ (LVR enable)			100	
$V_{DD} = 2.6\text{ V}$ (LVR enable)			30			60	

NOTE: In STOP (I_{DD3}), IDLE (I_{DD2}) current, current by ADC module is not included.

Table 13-3. AC Electrical Characteristics

($T_A = -40\text{ }^\circ\text{C}$ to $+85\text{ }^\circ\text{C}$, $V_{DD} = 2.0\text{ V}$ to 5.5 V)

Parameter	Symbol	Conditions	Min	Typ	Max	Unit
Interrupt input low width	t_{INTL}	INT0, INT1 $V_{DD} = 5\text{ V} \pm 10\%$	–	200	–	ns
RESET input low width	t_{RSL}	Input $V_{DD} = 5\text{ V} \pm 10\%$	–	1	–	us

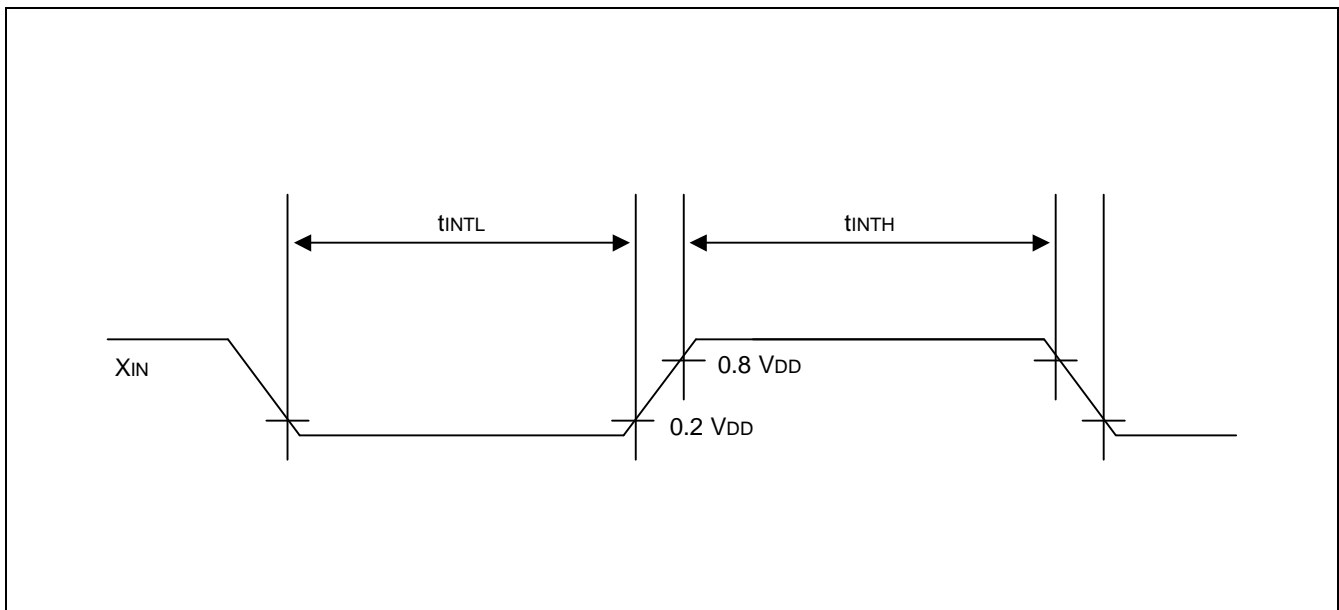


Figure 13-1. Input Timing Measurement Points

Table 13-4. Oscillator Characteristics

(T_A = -40°C to +85°C)

Oscillator	Clock Circuit	Test Condition	Min	Typ	Max	Unit
Main crystal or ceramic		V _{DD} = 4.5 to 5.5 V	1	-	10	MHz
		V _{DD} = 2.7 to 4.5 V	1	-	6	MHz
		V _{DD} = 2.0 to 2.7 V	1	-	3	MHz
External clock (Main System)		V _{DD} = 4.5 to 5.5 V	1	-	10	MHz
		V _{DD} = 2.7 to 4.5 V	1	-	6	MHz
		V _{DD} = 2.0 to 2.7 V	1	-	3	MHz
External RC oscillator	-	V _{DD} = 4.75 to 5.25 V Tolerance:10 %	-	4	-	MHz
Internal RC		V _{DD} = 4.75 to 5.25 V		3.2		
Oscillator				0.5		

Table 13-5. Oscillation Stabilization Time

(T_A = -40 °C to +85 °C, V_{DD} = 3.0 V to 5.5 V)

Oscillator	Test Condition	Min	Typ	Max	Unit
Main crystal	f _{OSC} > 1.0 MHz	-	-	20	ms
Main ceramic	Oscillation stabilization occurs when V _{DD} is equal to the minimum oscillator voltage range.	-	-	10	ms
External clock (main system)	X _{IN} input high and low width (t _{XH} , t _{XL})	25	-	500	ns
Oscillator stabilization	t _{WAIT} when released by a reset ⁽¹⁾	-	2 ¹⁶ /f _{OSC}	-	ms
wait time	t _{WAIT} when released by an interrupt ⁽²⁾	-	-	-	ms

NOTES:

- f_{OSC} is the oscillator frequency.
- The duration of the oscillator stabilization wait time, t_{WAIT}, when it is released by an interrupt is determined by the settings in the basic timer control register, BTCON.

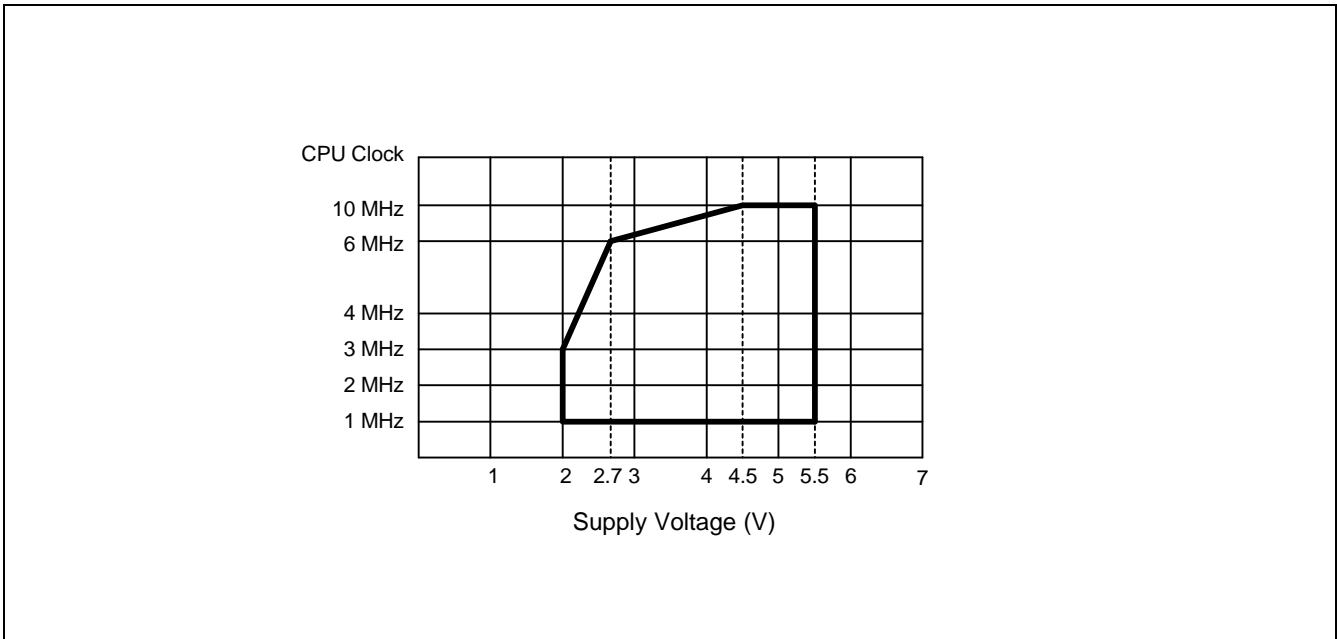


Figure 13-2. Operating Voltage Range

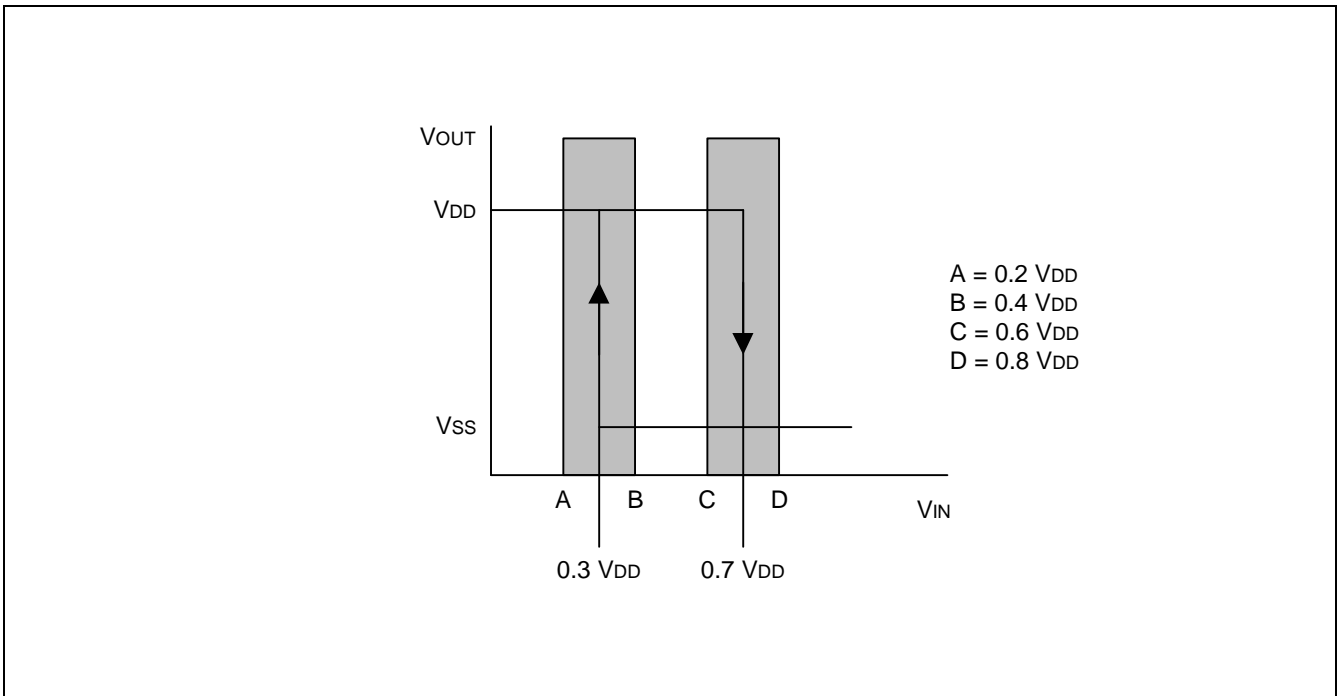


Figure 13-3. Schmitt Trigger Input Characteristics Diagram

Table 13-6. Data Retention Supply Voltage in Stop Mode

($T_A = -40\text{ }^\circ\text{C}$ to $+85\text{ }^\circ\text{C}$, $V_{DD} = 2.0\text{ V}$ to 5.5 V)

Parameter	Symbol	Conditions	Min	Typ	Max	Unit
Data retention supply voltage	V_{DDDR}	Stop mode	2.0	–	5.5	V
Data retention supply current	I_{DDDR}	Stop mode; $V_{DDDR} = 2.0\text{ V}$	–	0.1	5	μA

NOTE: Supply current does not include current drawn through internal pull-up resistors or external output current loads.

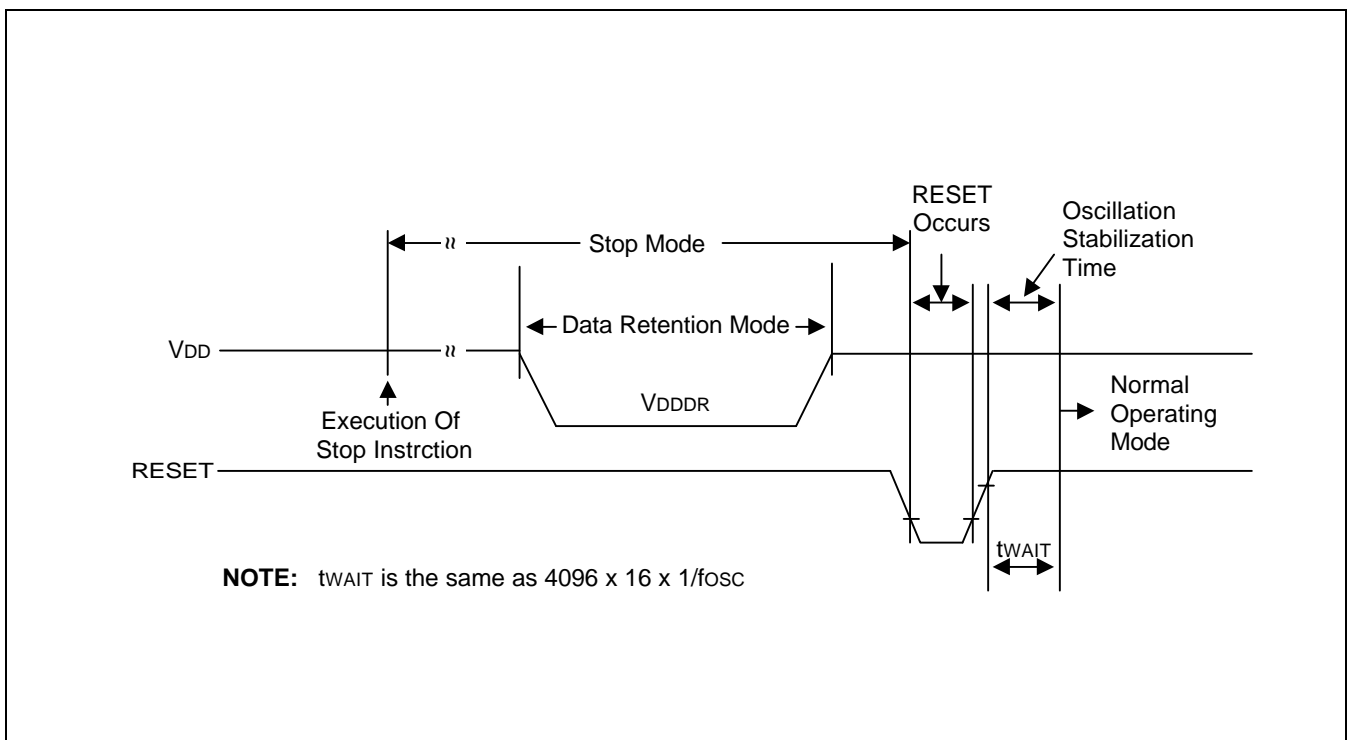


Figure 13-4. Stop Mode Release Timing When Initiated by a RESET

Table 13-7. A/D Converter Electrical Characteristics

(T_A = -40 °C to +85 °C, V_{DD} = 2.7 V to 5.5 V, V_{SS} = 0 V)

Parameter	Symbol	Test Conditions	Min	Typ	Max	Unit
Total accuracy	-	V _{DD} = 5.12 V CPU clock = 10 MHz V _{SS} = 0 V	-	-	± 3	LSB
Integral linearity error	ILE	"	-	-	± 2	
Differential linearity error	DLE	"	-	-	± 1	
Offset error of top	EOT	"	-	± 1	± 3	
Offset error of bottom	EOB	"	-	± 1	± 2	
Conversion time (1)	t _{CON}	f _{OSC} = 10 MHz	-	20	-	μs
Analog input voltage	V _{IAN}	-	V _{SS}	-	V _{DD}	V
Analog input impedance	R _{AN}	-	2	-	-	MΩ
Analog input current	I _{ADIN}	V _{DD} = 5 V	-	-	10	μA
Analog block current (2)	I _{ADC}	V _{DD} = 5 V	-	1	3	mA
		V _{DD} = 3 V		0.5	1.5	
		V _{DD} = 5 V power down mode	-	100	500	nA

NOTES:

1. "Conversion time" is the time required from the moment a conversion operation starts until it ends.
2. I_{ADC} is operating current during A/D conversion.

Table 13-8. LVR Circuit Characteristics

(T_A = 25 °C, V_{DD} = 2.0 V to 5.5 V)

Parameter	Symbol	Conditions	Min	Typ	Max	Unit
Low voltage reset	V _{LVR}	–	–	2.3 3.0 3.9		V
LVR hysteresis voltage	V _{HYS}		–	0.3	–	V
Power supply voltage rise time	t _R		10		(note)	us
Power supply voltage off time	t _{OFF}		0.5			s

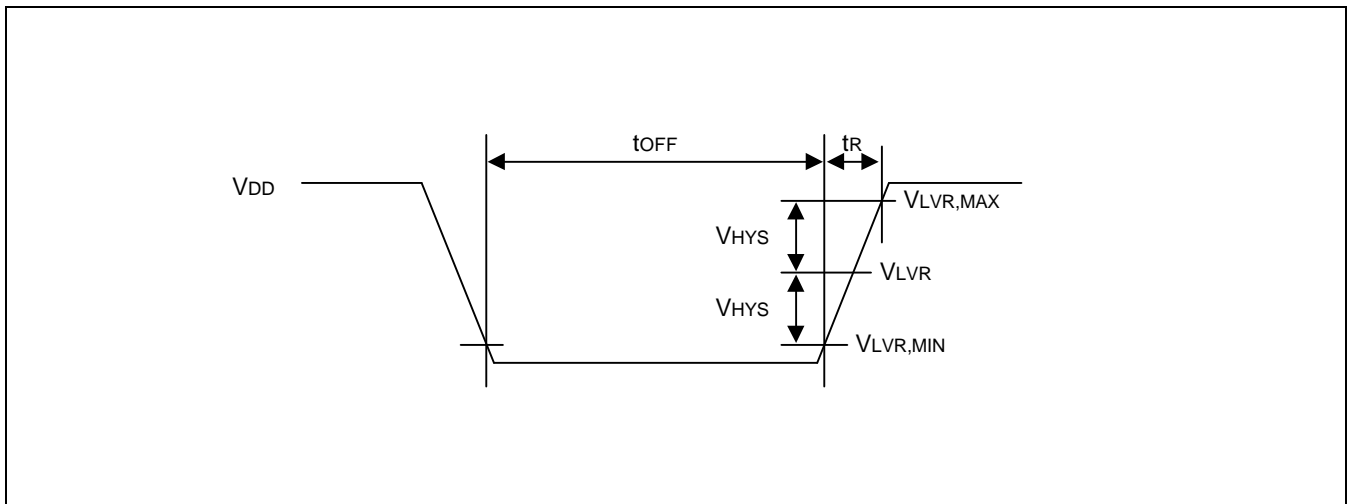
NOTE: 2¹⁶/f_x (= 6.55 ms at f_x = 10 MHz)

Figure 13-5. LVR Reset Timing

14

MECHANICAL DATA

OVERVIEW

The S3C9452/C9454 is available in a 20-pin DIP package (Samsung: 20-DIP-300A), a 20-pin SOP package (Samsung: 20-SOP-375), a 16-pin DIP package (Samsung: 16-DIP-300A). Package dimensions are shown in Figure 15-1, 15-2, and 15-3.

The S3C9442/C9444 is available in a 8-pin DIP package (SAMSUNG 8-DIP-300A), a 8-pin SOP package (SAMSUNG 8-SOP-225).

Package dimensions are shown in figure 14-4 and 14-5.

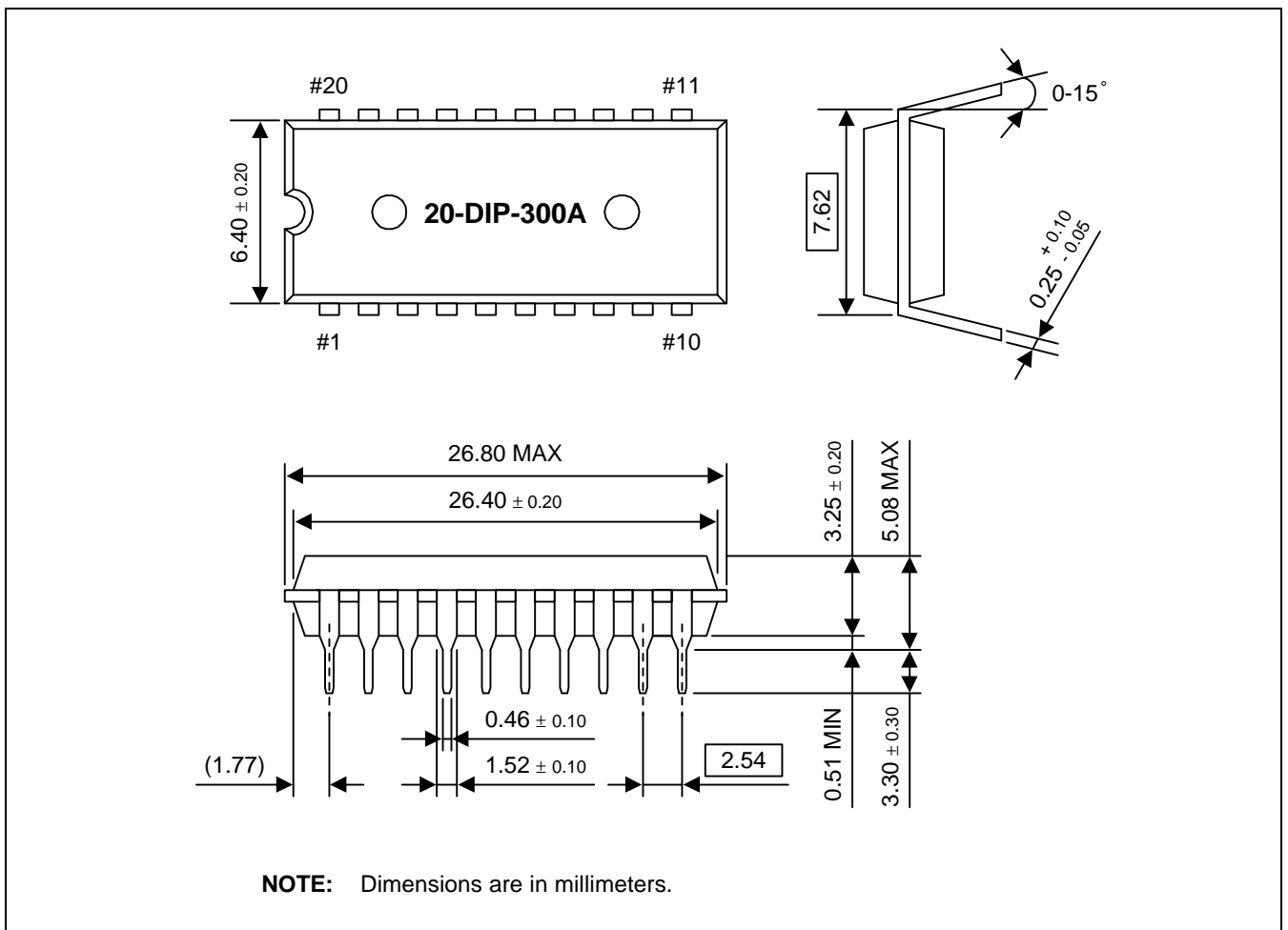


Figure 14-1. 20-DIP-300A Package Dimensions

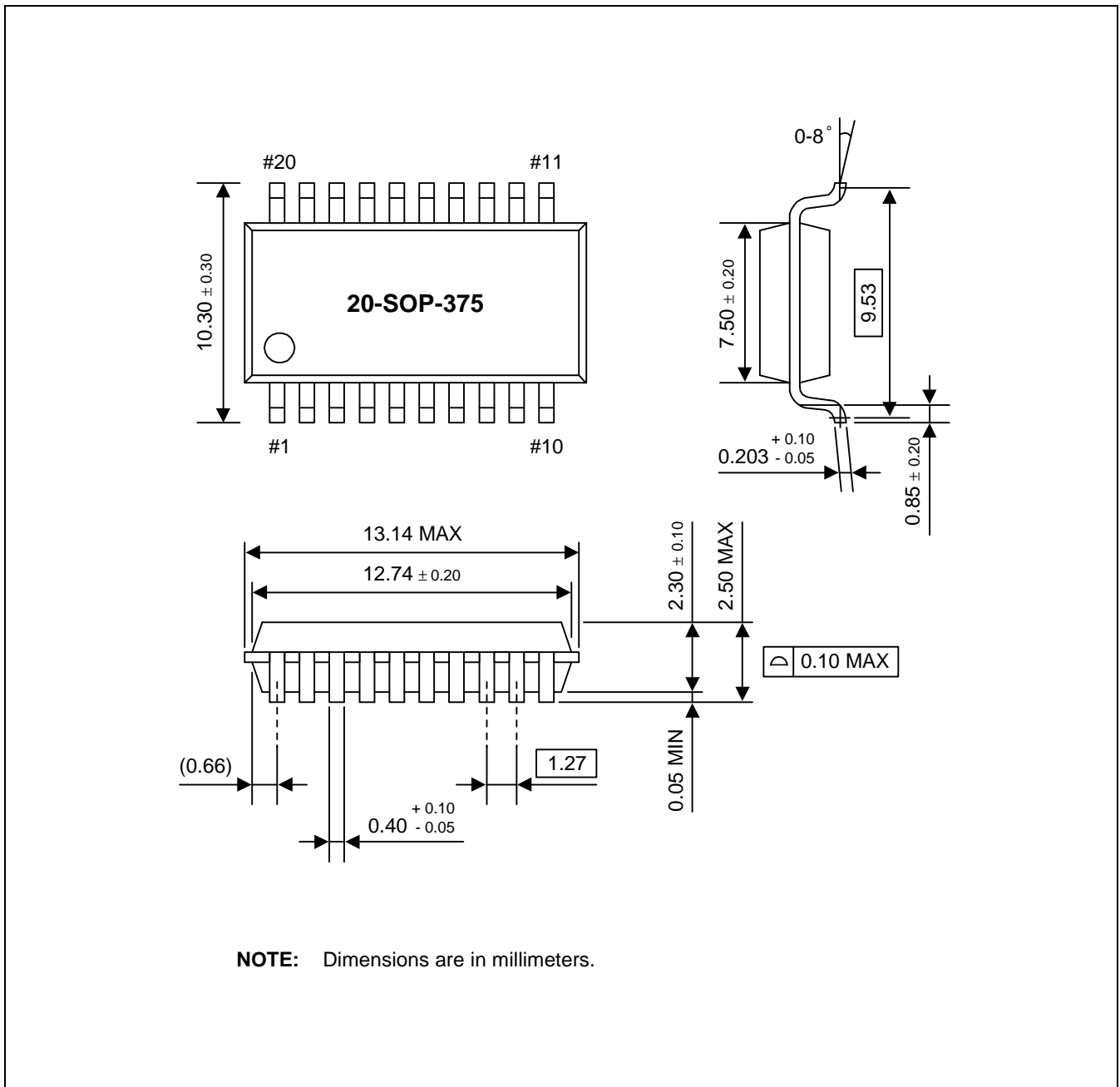


Figure 14-2. 20-SOP-375 Package Dimensions

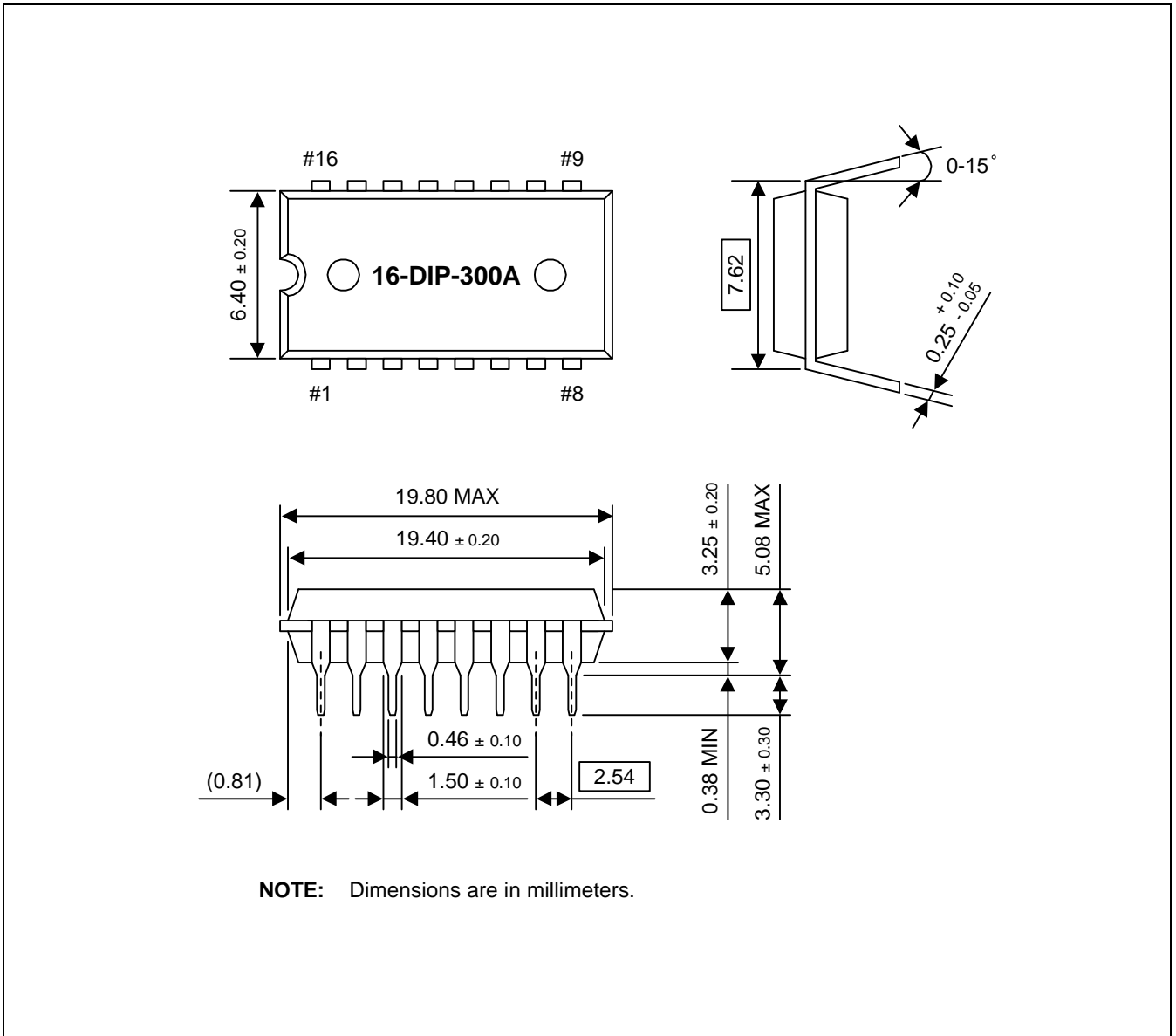


Figure 14-3. 16-DIP-300A Package Dimensions

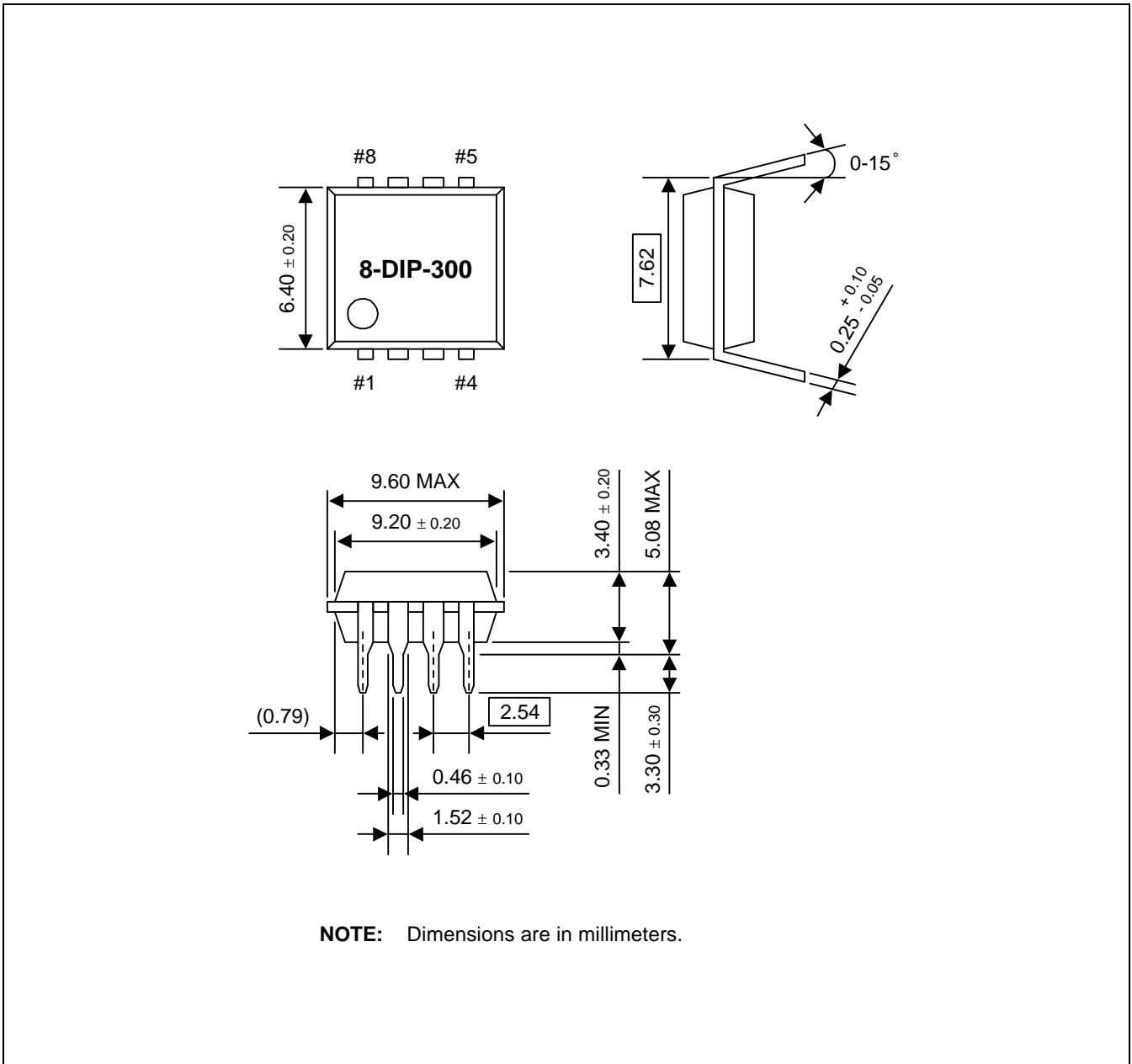
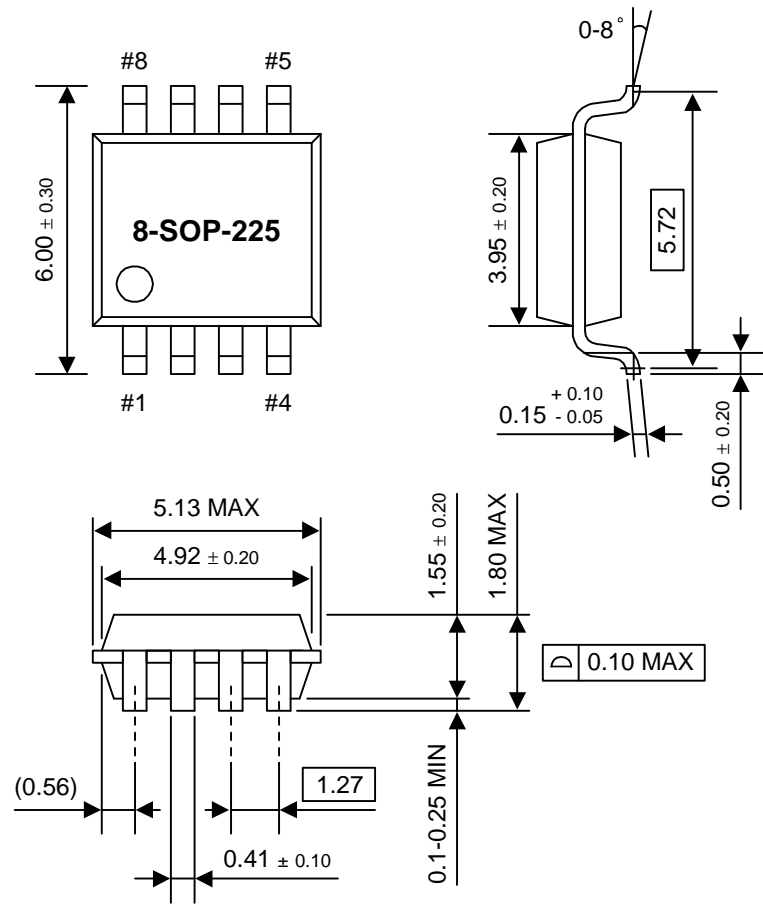


Figure 14-4. 8-DIP-300 Package Dimensions



NOTE: Dimensions are in millimeters.

Figure 14-5. 8-SOP-225 Package Dimensions

15

S3F9444/F9454 MTP

OVERVIEW

The S3F9444/F9454 single-chip CMOS microcontroller is the MTP (Multi Time Programmable) version of the S3C9442/C9444/C9452/C9454 microcontroller. It has an on-chip Flash ROM instead of masked ROM. The Flash ROM is accessed by serial data format.

The S3F9444/F9454 is fully compatible with the S3C9442/C9444/C9452/C9454, in function, in D.C. electrical characteristics, and in pin configuration. Because of its simple programming requirements, the S3F9444/F9454 is ideal for use as an evaluation chip for the S3C9442/C9444/C9452/C9454.

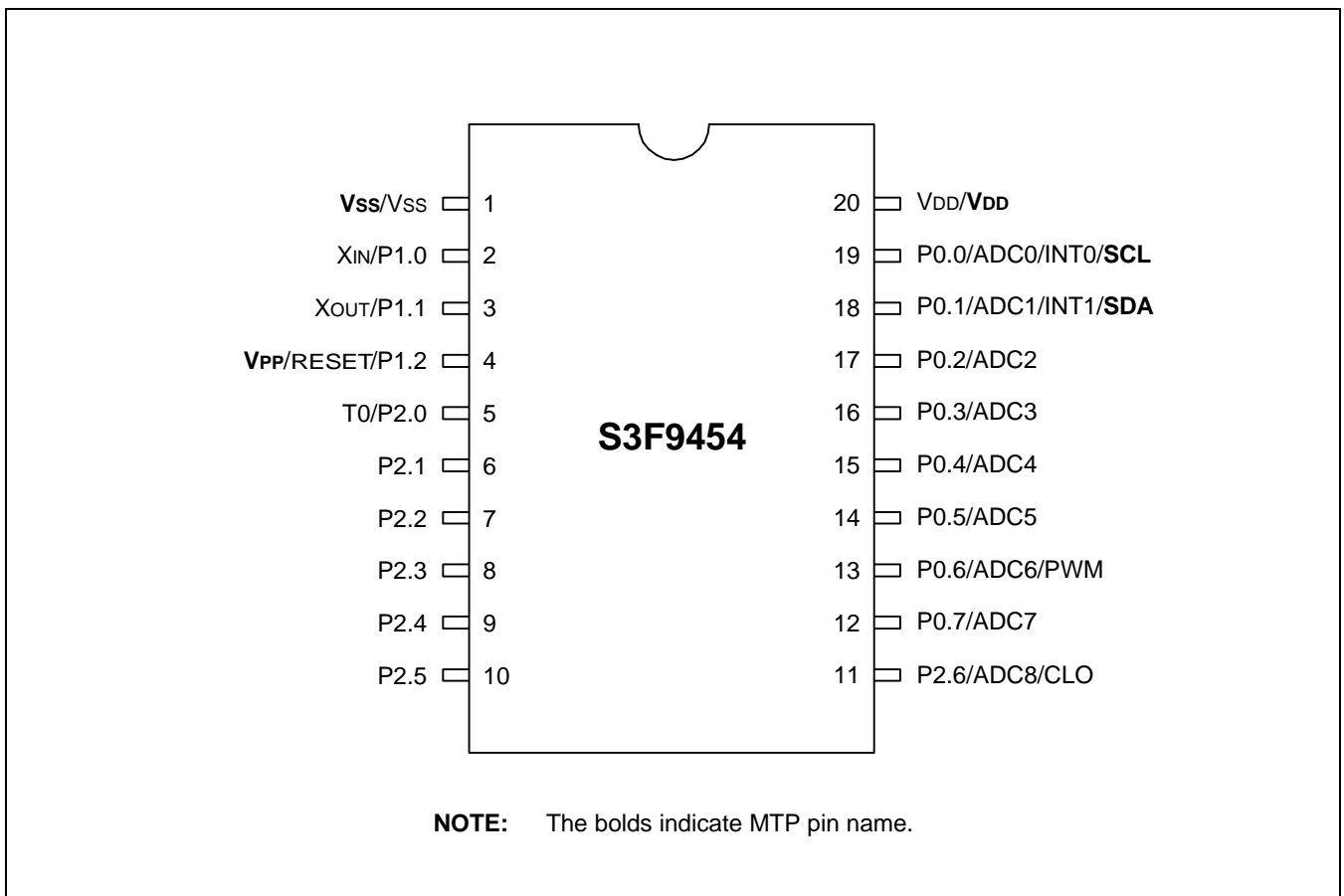


Figure 15-1. Pin Assignment Diagram (20-Pin Package)

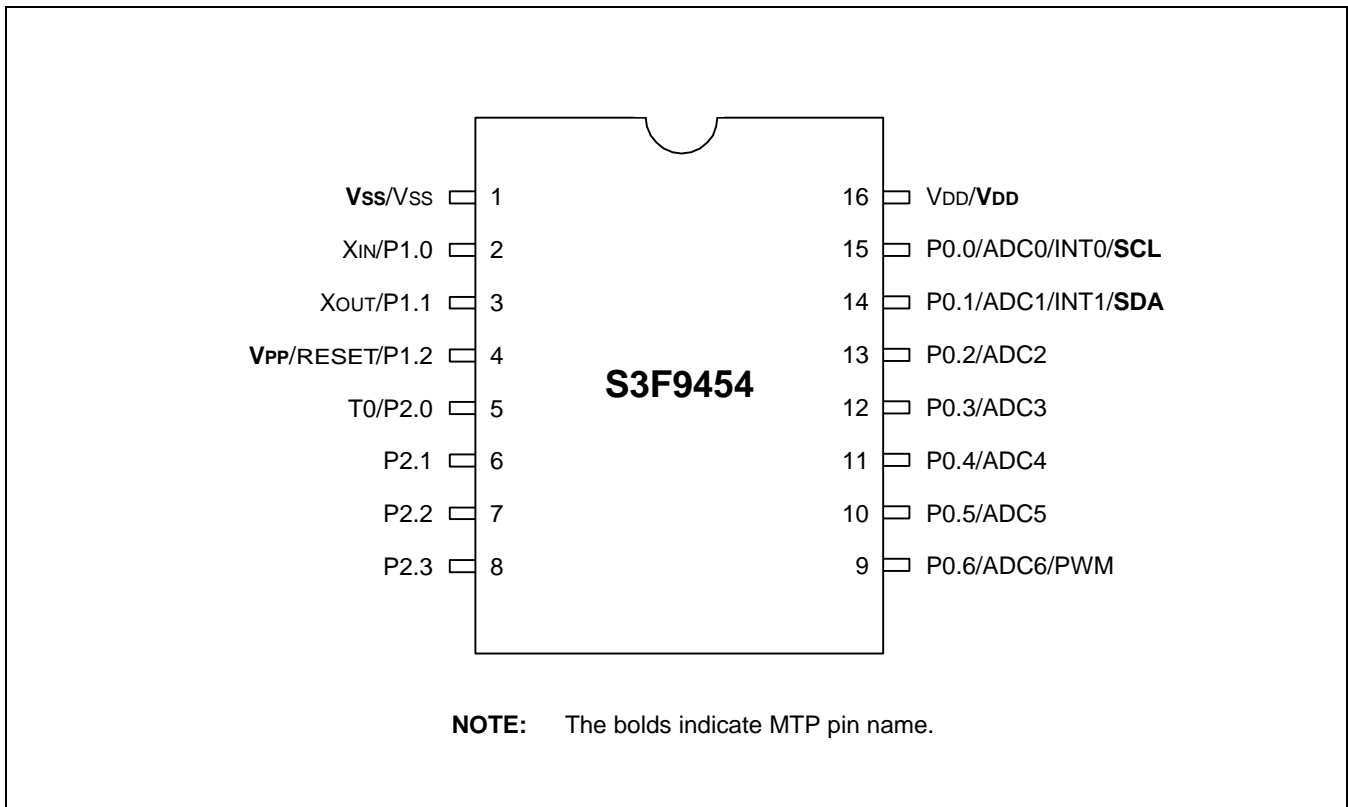


Figure 15-2. Pin Assignment Diagram (16-Pin Package)

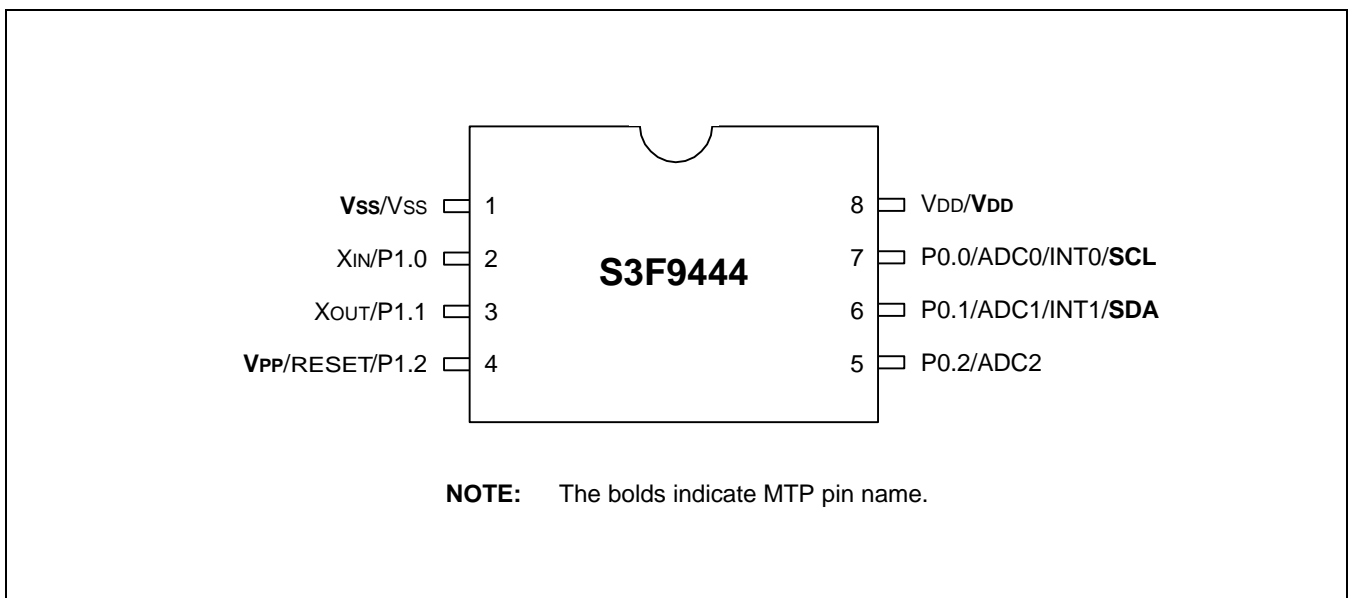


Figure 15-3. Pin Assignment Diagram (8-Pin Package)

Table 15-1. Descriptions of Pins Used to Read/Write the Flash ROM

Main Chip Pin Name	During Programming			
	Pin Name	Pin No.	I/O	Function
P0.1	SDA	18 (20-pin) 14 (16-pin)	I/O	Serial data pin (output when reading, Input when writing) Input and push-pull output port can be assigned
P0.0	SCL	19 (20-pin) 15 (16-pin)	I	Serial clock pin (input only pin)
RESET, P1.2	V _{PP}	4	I	Power supply pin for flash ROM cell writing (indicates that MTP enters into the writing mode). When 12.5 V is applied, MTP is in writing mode and when 5 V is applied, MTP is in reading mode. (Option)
V _{DD} /V _{SS}	V _{DD} /V _{SS}	20 (20-pin), 16 (16-pin) 1 (20-pin), 1 (16-pin)	I	Logic power supply pin.

Table 15-2. Comparison of S3F9444/F9454 and S3C9442/C9444/C9452/C9454 Features

Characteristic	S3F9444/F9454	S3C9442/C9444/C9452/C9454
Program Memory	4 Kbyte Flash ROM	2K/4K byte mask ROM
Operating Voltage (V _{DD})	2.0 V to 5.5 V	2.0 V to 5.5 V
OTP Programming Mode	V _{DD} = 5 V, V _{PP} = 12.5 V	
Pin Configuration	20 DIP/20 SOP/16 DIP/8 DIP/8 SOP	
EPROM Programmability	User Program multi time	Programmed at the factory

OPERATING MODE CHARACTERISTICS

When 12.5 V is supplied to the V_{PP} pin of the S3F9444/F9454 Flash ROM programming mode is entered. The operating mode (read, write, or read protection) is selected according to the input signals to the pins listed in Table 15-3 below.

Table 15-3. Operating Mode Selection Criteria

V _{DD}	V _{PP}	REG/MEM	Address (A15–A0)	R/W	Mode
5 V	5 V	0	0000H	1	Flash ROM read
	12.5 V	0	0000H	0	Flash ROM program
	12.5 V	0	0000H	1	Flash ROM verify
	12.5 V	1	0E3FH	0	Flash ROM read protection

NOTE: "0" means Low level; "1" means High level.

16

DEVELOPMENT TOOLS

OVERVIEW

Samsung provides a powerful and easy-to-use development support system in turnkey form. The development support system is configured with a host system, debugging tools, and support software. For the host system, any standard computer that operates with MS-DOS as its operating system can be used. One type of debugging tool including hardware and software is provided: the sophisticated and powerful in-circuit emulator, SMDS2+, for S3C7, S3C9, S3C8 families of microcontrollers. The SMDS2+ is a new and improved version of SMDS2. Samsung also offers support software that includes debugger, assembler, and a program for setting options.

SHINE

Samsung Host Interface for in-circuit Emulator, SHINE, is a multi-window based debugger for SMDS2+. SHINE provides pull-down and pop-up menus, mouse support, function/hot keys, and context-sensitive hyper-linked help. It has an advanced, multiple-windowed user interface that emphasizes ease of use. Each window can be sized, moved, scrolled, highlighted, added, or removed completely.

SAMA ASSEMBLER

The Samsung Arrangeable Microcontroller (SAM) Assembler, SAMA, is a universal assembler, and generates object code in standard hexadecimal format. Assembled program code includes the object code that is used for ROM data and required SMDS program control data. To assemble programs, SAMA requires a source file and an auxiliary definition (DEF) file with device specific information.

SASM86

The SASM86 is a relocatable assembler for Samsung's S3C9-series microcontrollers. The SASM86 takes a source file containing assembly language statements and translates into a corresponding source code, object code and comments. The SASM86 supports macros and conditional assembly. It runs on the MS-DOS operating system. It produces the relocatable object code only, so the user should link object file. Object files can be linked with other object files and loaded into memory.

HEX2ROM

HEX2ROM file generates ROM code from HEX file which has been produced by assembler. ROM code must be needed to fabricate a microcontroller which has a mask ROM. When generating the ROM code (.OBJ file) by HEX2ROM, the value "FF" is filled into the unused ROM area upto the maximum ROM size of the target device automatically.

TARGET BOARDS

Target boards are available for all S3C9-series microcontrollers. All required target system cables and adapters are included with the device-specific target board.

MTPs

Multi times programmable microcontrollers (MTPs) are under development for S3C9442/C9444/C9452/C9454 microcontroller.

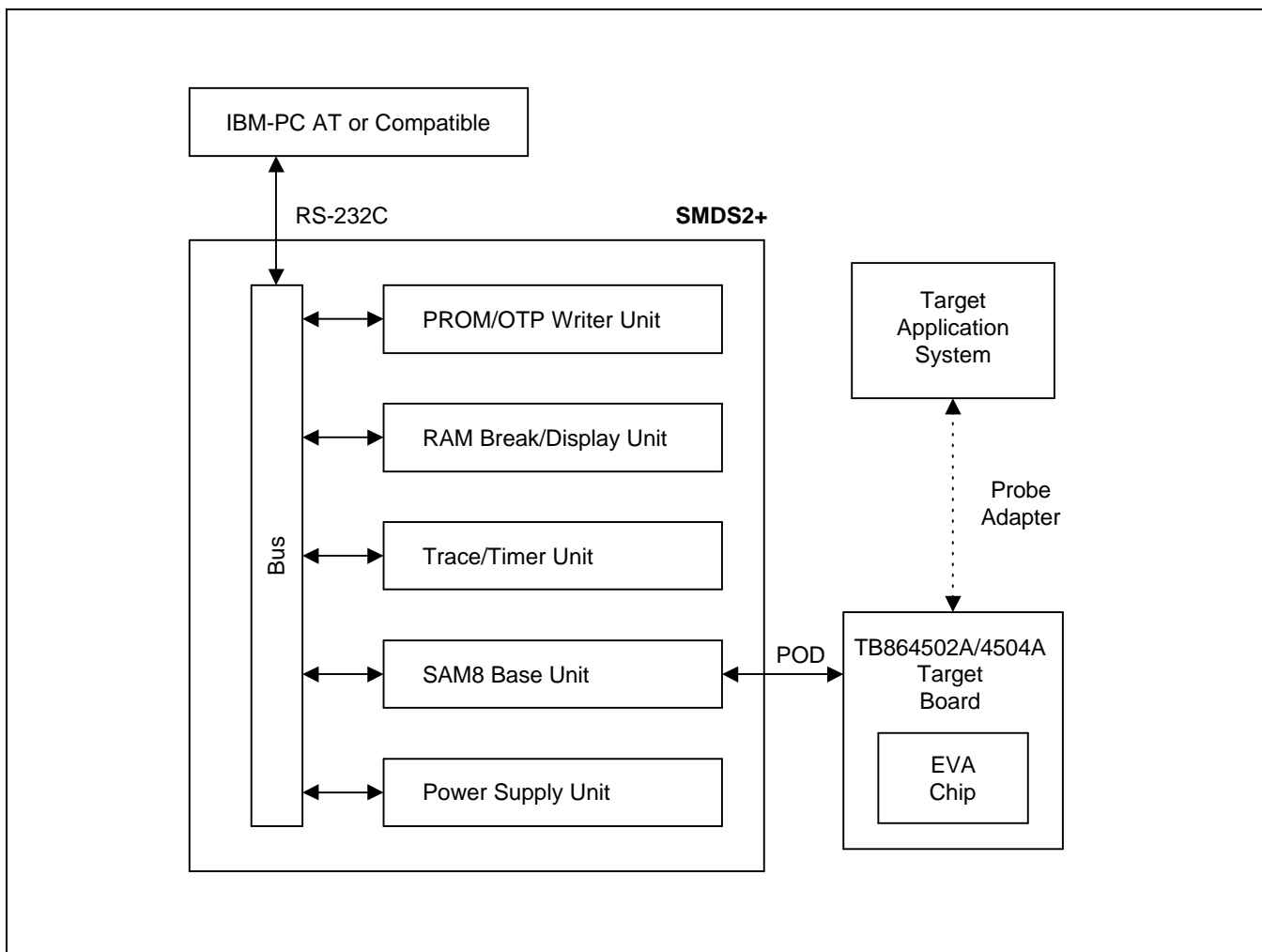


Figure 16-1. SMDS Product Configuration (SMDS2+)

TB9442/4/9452/4 TARGET BOARD

The TB9442/4/9452/4 target board is used for the S3C9442/C9444/C9452/C9454 microcontrollers. It is supported by the SMDS2+ development systems.

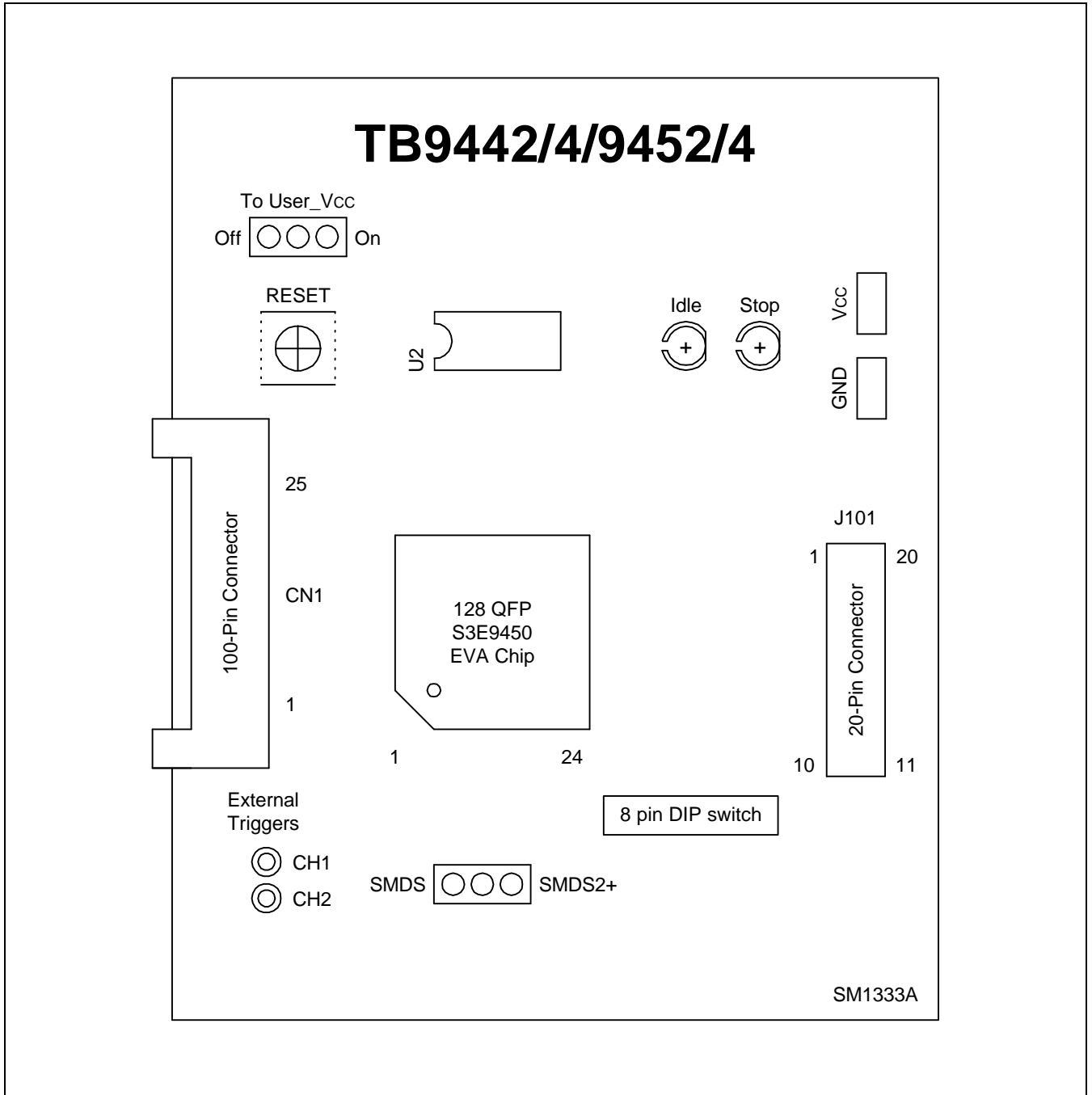

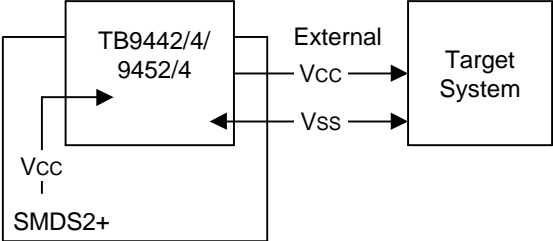

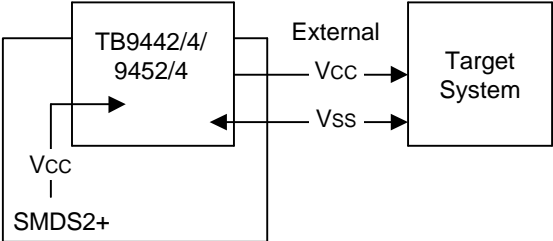


Figure 16-2. TB9442/4/9452/4 Target Board Configuration

Table 16-1. Power Selection Settings for TB9442/4/9452/4

"To User_Vcc" Settings	Operating Mode	Comments
To user_Vcc off  on		The SMDS2+ main board supplies V_{CC} to the target board (evaluation chip) and the target system.
To user_Vcc off  on		The SMDS2+ main board supplies V_{CC} only to the target board (evaluation chip). The target system must have its own power supply.

NOTE: The following symbol in the "To User_Vcc" Setting column indicates the electrical short (off) configuration:



SMDS2+ Selection (SAM8)

In order to write data into program memory that is available in SMDS2+, the target board should be selected to be for SMDS2+ through a switch as follows. Otherwise, the program memory writing function is not available.

Table 16-2. The SMDS2+ Tool Selection Setting


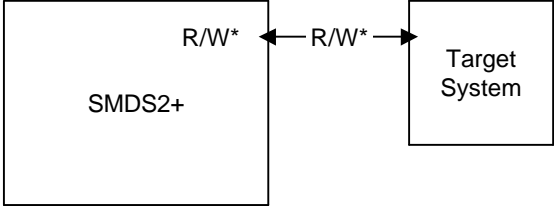
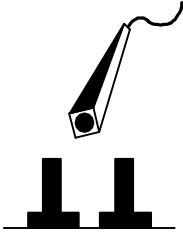
"SW1" Setting	Operating Mode
SMDS  SMDS2+	

Table 16-3. Using Single Header Pins as the Input Path for External Trigger Sources

Target Board Part	Comments
<p>External Triggers</p> <p>○ Ch1</p> <p>○ Ch2</p>	<div style="display: flex; align-items: center;">  <div style="margin-left: 20px;"> <p>Connector from External Trigger Sources of the Application System</p> </div> </div> <p>You can connect an external trigger source to one of the two external trigger channels (CH1 or CH2) for the SMDS2+ breakpoint and trace functions.</p>

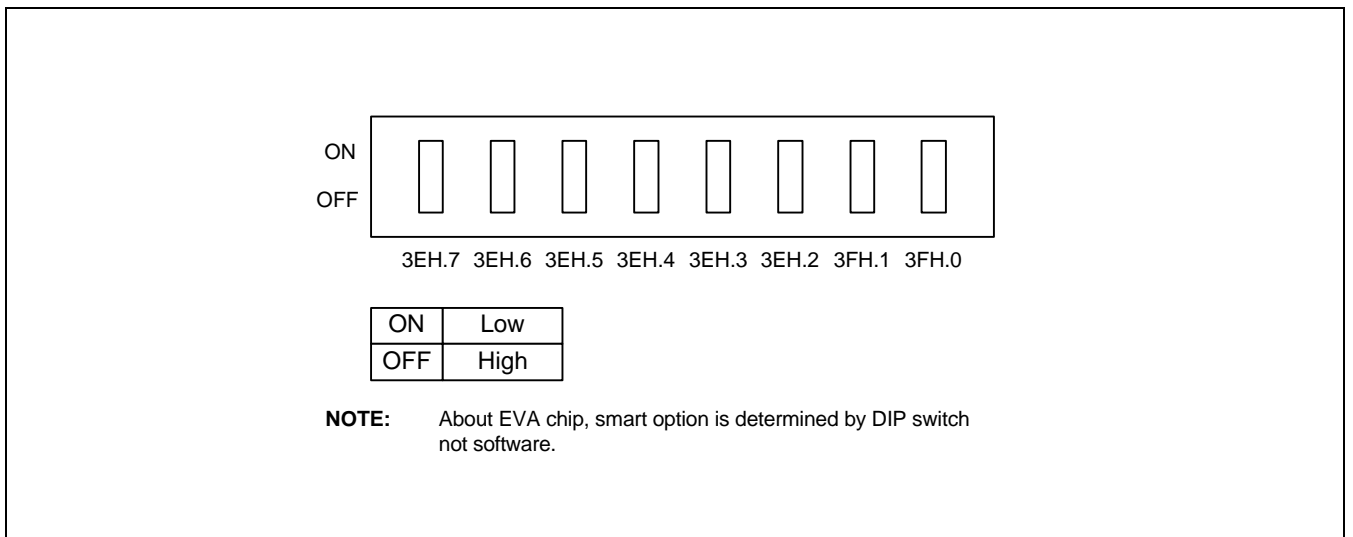


Figure 16-3. DIP Switch for Smart Option

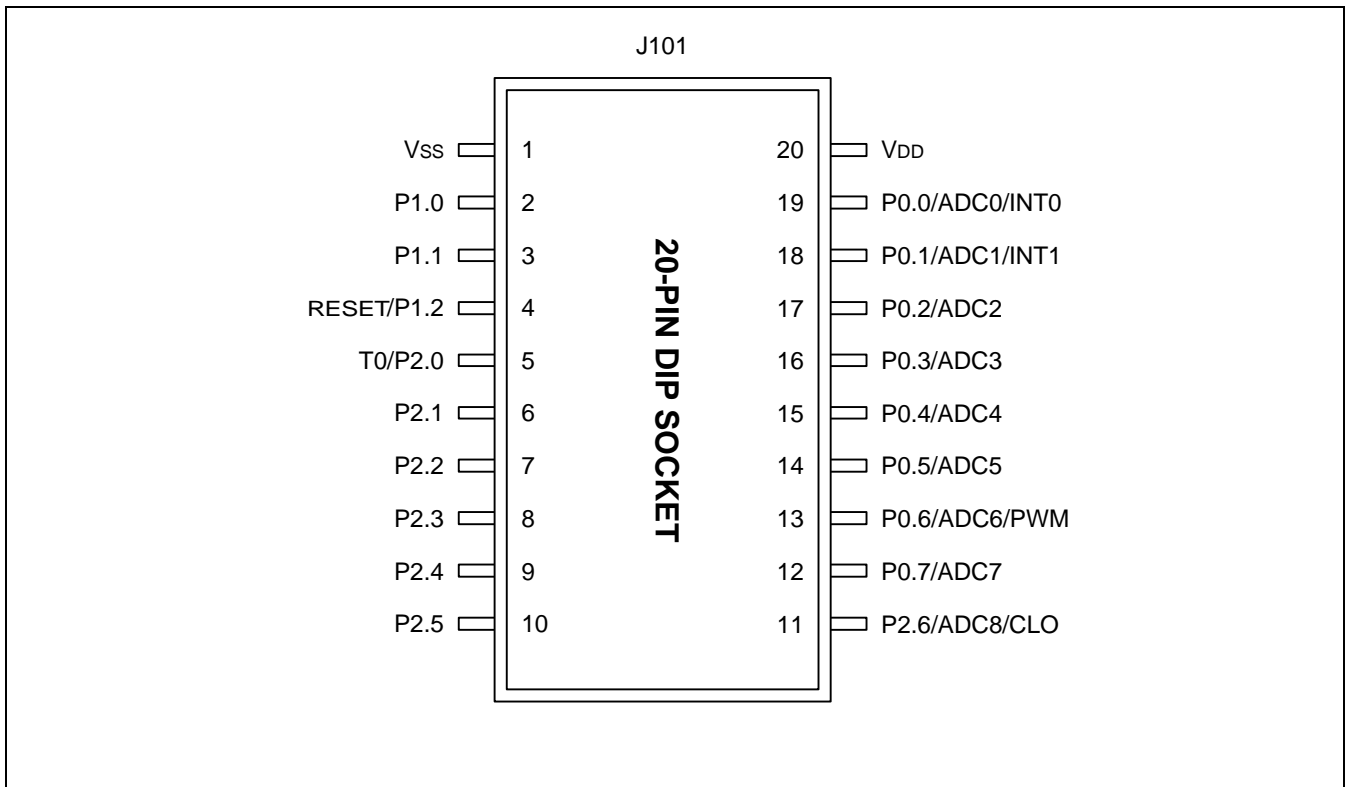


Figure 16-4. 20-Pin Connector for TB9442/4/9452/4

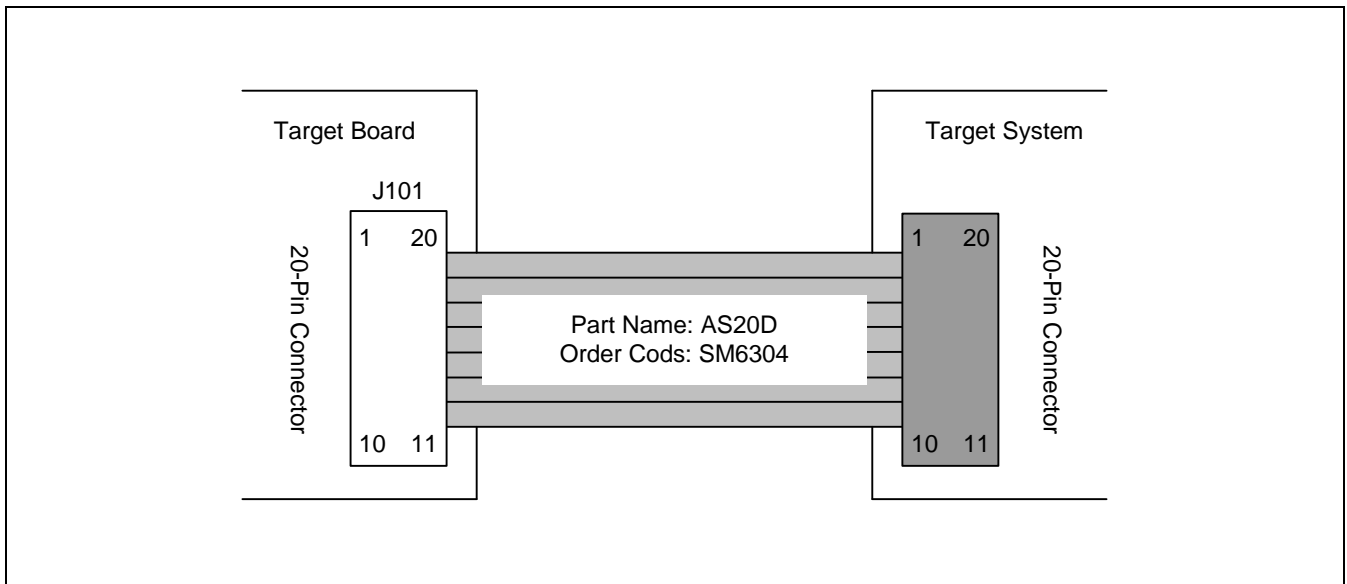


Figure 16-5. S3C9442/C9444/C9452/C9454 Probe Adapter for 20-DIP Package