

S4506

Photo IC for photointerrupters with encoder functions

The S4506 incorporates a 4-element photodiode array that provides 2-phase digital output in response to the input light status. Photointerrupters with encoder functions can be easily configured by using the S4506.

Features

- 2-phase (phases A and B) digital output
- Integrated with 4-element photodiode (pitch: 0.39 mm)
- Direct TTL connection
- Miniature plastic package

Applications

- Encoders for office machine, robots, and NC machines

Absolute maximum ratings (Ta=25 °C)

Parameter	Symbol	Value	Unit
Supply voltage	Vcc	-0.5 to +7	V
Output current	Io	20	mA
Power dissipation*1	Po	250	mW
Operating temperature	Topr	-30 to +80	°C
Storage temperature	Tstg	-40 to +85	°C
Soldering	-	230 °C, 5 s, at least 1.8 mm away from package surface	-

*1: Power dissipation decreases at a rate of 3.3 mW/°C above Ta=25 °C

Note: Exceeding the absolute maximum ratings even momentarily may cause a drop in product quality. Always be sure to use the product within the absolute maximum ratings.

Electrical and optical characteristics (Ta =25 °C, Vcc=5 V, unless otherwise noted)

Parameter	Symbol	Condition	Min.	Typ.	Max.	Unit	
Supply voltage	Vcc		4.5	-	5.5	V	
Low level output voltage	VOL	IOL=8 mA	-	0.1	0.4	V	
High level output voltage	VOH	IOH=0 mA	4.5	-	-	V	
Current consumption	ICCL	VOA=VOB="L"	-	6	12	mA	
	ICCH	VOA=VOB="H"	-	3	12	mA	
Peak sensitivity wavelength	λp		-	870	-	nm	
Slit movement speed	Vp	Ev=200 lx*2 *3	-	-	10,000	slit/s	
Transfer characteristics	Duty ratio*4	DA	Ev=200 lx*2	35	50	65	%
		DB	f=2.5 kHz				
	Phase difference	θAB	f=2.5 kHz, Ev=200 to 700 lx*2	60	90	120	deg
Threshold illuminance*5	EVD	"A" light source, f=2.5 kHz	-	30	120	lx	

*2: Ev is illuminance emitted from a CIE standard "A" light source (tungsten lamp).

*3: A collimated light source and a recommended slit moving at a constant speed are used.

[Delay time between the instant that the slit passes through the output transition position and the actual output transition should be less than 1/8 of the slit cycle.]

*4: See operation timing diagram (page 4)

*5: Minimum illuminance from an "A" light source when the duty ratio of phases A and B is between 35 and 65%.

Block diagram

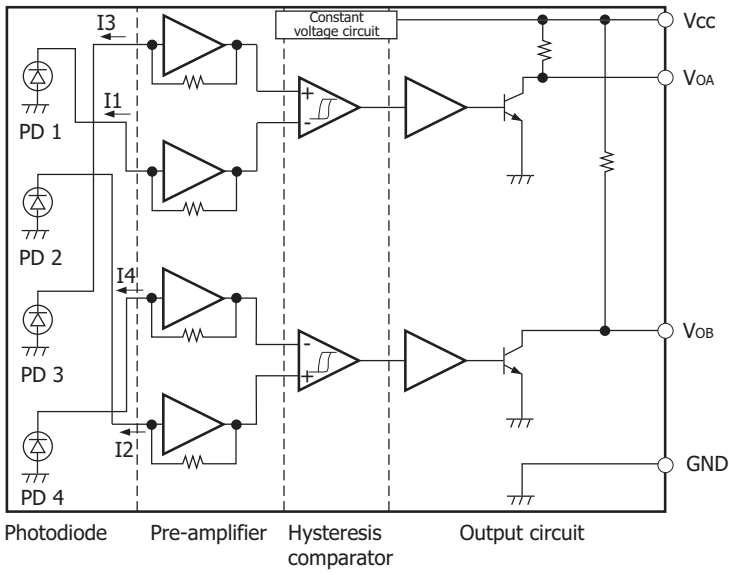

INPUT		OUTPUT	
		V _{OA}	V _{OB}
$I_1 < I_3$	$I_2 > I_4$	L	L
$I_1 < I_3$	$I_2 < I_4$	L	H
$I_1 > I_3$	$I_2 > I_4$	H	L
$I_1 > I_3$	$I_2 < I_4$	H	H

KPIC0012ED

Dimensional outline (unit: mm)

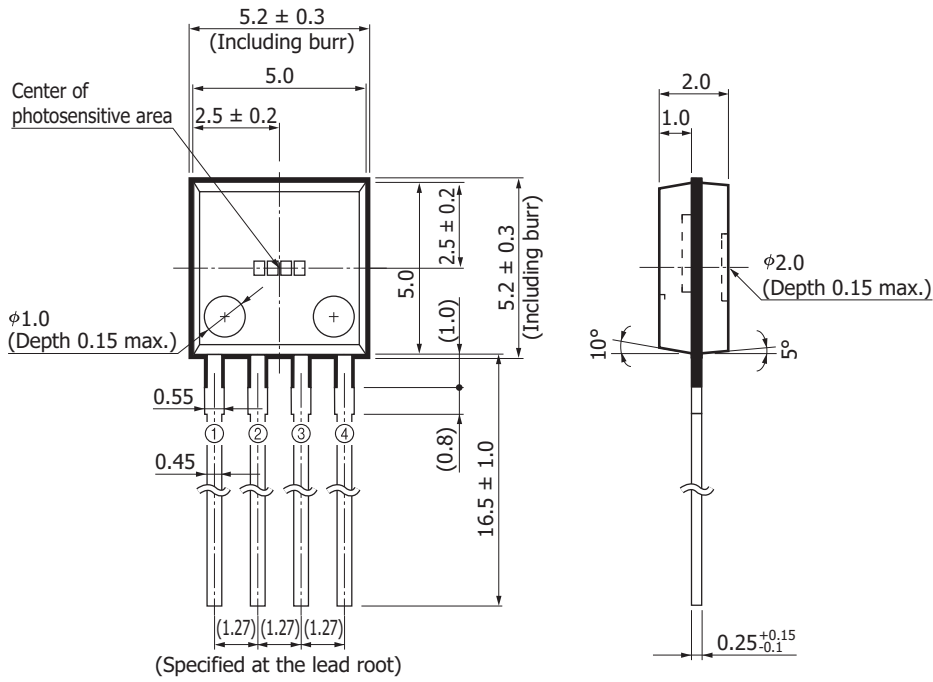

(Specified at the lead root)

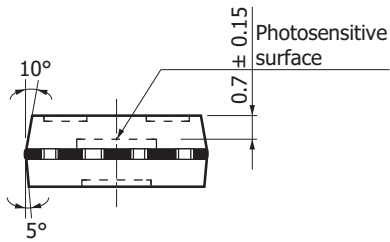

- ① V_{OA}
- ② V_{CC}
- ③ GND
- ④ V_{OB}

Tolerance unless otherwise noted: ±0.1, ±2°
 Shaded area indicates burr.
 Values in parentheses are not guaranteed, but for reference

KPICA0016EC

Details of photodiodes (unit: mm)

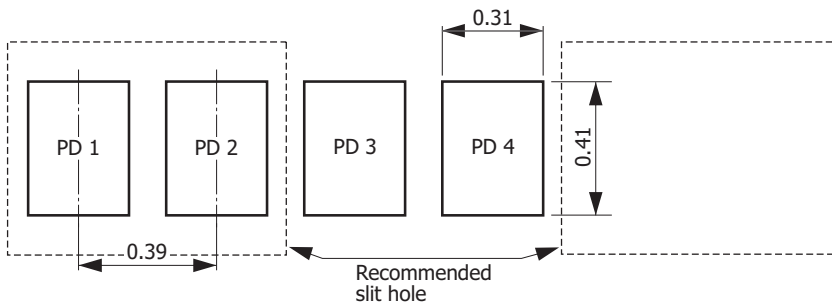

KPIC0013EE

Recommended slit (unit: mm)

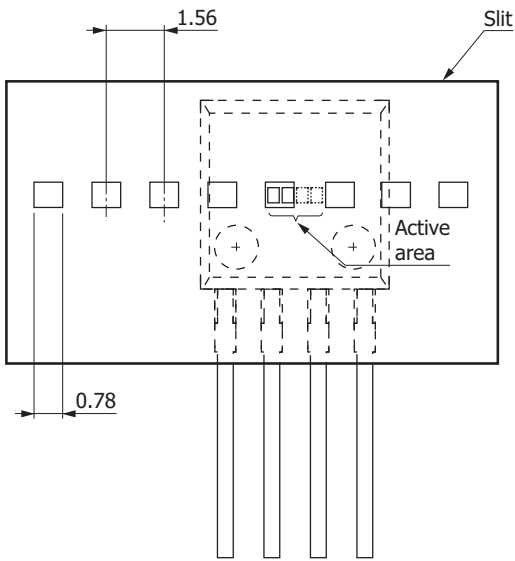

Light source: Collimated light LED

KPIC0014EC

Operation timing diagram

Outputs VOA and VOB change as shown when the slit is moved to the right at a constant speed from the position shown on the left figure.

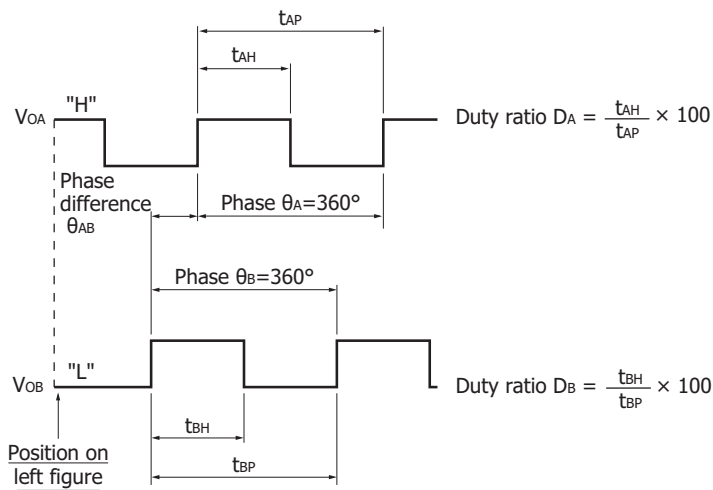

KPIC0015ED

Related information

www.hamamatsu.com/sp/ssd/doc_en.html

■ Precautions

- Disclaimer
- Metal, ceramic, plastic products

Information described in this material is current as of October 2017.

Product specifications are subject to change without prior notice due to improvements or other reasons. This document has been carefully prepared and the information contained is believed to be accurate. In rare cases, however, there may be inaccuracies such as text errors. Before using these products, always contact us for the delivery specification sheet to check the latest specifications.

The product warranty is valid for one year after delivery and is limited to product repair or replacement for defects discovered and reported to us within that one year period. However, even if within the warranty period we accept absolutely no liability for any loss caused by natural disasters or improper product use. Copying or reprinting the contents described in this material in whole or in part is prohibited without our prior permission.

HAMAMATSU

www.hamamatsu.com

HAMAMATSU PHOTONICS K.K., Solid State Division

1126-1 Ichino-cho, Higashi-ku, Hamamatsu City, 435-8558 Japan, Telephone: (81) 53-434-3311, Fax: (81) 53-434-5184

U.S.A.: Hamamatsu Corporation: 360 Foothill Road, Bridgewater, N.J. 08807, U.S.A., Telephone: (1) 908-231-0960, Fax: (1) 908-231-1218, E-mail: usa@hamamatsu.com

Germany: Hamamatsu Photonics Deutschland GmbH: Arzbergerstr. 10, D-82211 Herrsching am Ammersee, Germany, Telephone: (49) 8152-375-0, Fax: (49) 8152-265-8, E-mail: info@hamamatsu.de

France: Hamamatsu Photonics France S.A.R.L.: 19, Rue du Saule Trapu, Parc du Moulin de Massy, 91882 Massy Cedex, France, Telephone: 33-(1) 69 53 71 00, Fax: 33-(1) 69 53 71 10, E-mail: infos@hamamatsu.fr

United Kingdom: Hamamatsu Photonics UK Limited: 2 Howard Court, 10 Tewin Road, Welwyn Garden City, Hertfordshire AL7 1BW, United Kingdom, Telephone: (44) 1707-294888, Fax: (44) 1707-325777, E-mail: info@hamamatsu.co.uk

North Europe: Hamamatsu Photonics Norden AB: Torshamnsgatan 35 16440 Kista, Sweden, Telephone: (46)8-509 031 00, Fax: (46)8-509 031 01, E-mail: info@hamamatsu.se

Italy: Hamamatsu Photonics Italia S.r.l.: Strada della Moia, 1 int. 6, 20020 Arese (Milano), Italy, Telephone: (39)02-93 58 17 33, Fax: (39)02-93 58 17 41, E-mail: info@hamamatsu.it

China: Hamamatsu Photonics (China) Co., Ltd.: B1201, Jiaming Center, No.27 Dongsanhuan Beilu, Chaoyang District, Beijing 100020, China, Telephone: (86) 10-6586-6006, Fax: (86) 10-6586-2866, E-mail: hpc@hamamatsu.com.cn

Taiwan: Hamamatsu Photonics Taiwan Co., Ltd.: 8F-3, No. 158, Section2, Gongdao 5th Road, East District, Hsinchu, 300, Taiwan R.O.C. Telephone: (886)03-659-0080, Fax: (886)03-659-0081, E-mail: info@tw.hpik.co.jp