



FOR MESSRS:

DATE: Feb 24. 2004

TENTATIVE

TENTATIVE SPECIFICATIONS

1,269cm (50 Inch) Wide Plasma Display Module

MODEL : S50HW-XB02

(PAL/NTSC)

- * This specification will be approved by both CUSTOMER and Samsung SDI Co.,Ltd.
- * Please return one of this specification with your signature for approval.

Proposed by:

Approved by:

Signature _____

Signature _____.

General Manager. Yeonyong Choo

Quality Innovation Team,

PDP) Division,

Samsung SDI Co., Ltd

SAMSUNG SDI CO.,LTD.

CONFIDENTIAL



SamsungSDI Corporation

Specification

Plasma Display Module

Revision History

Revision	Date	Description Of Changes	Approval
1	Feb 24. 2003	Newly established	-



TABLE OF CONTENTS

1. DESCRIPTION	5
2. FEATURES	5
3. PRODUCT NAME AND MODEL NUMBER.	5
4. FUNCTION OUTLINE	5
5. BLOCK DIAGRAM	6
6. DISPLAY CHARACTERISTICS	7
6.1 Display Performance	7
6.2 Display Cell Arrangement	8
6.3 Luminance Measurement Condition	9
6.4 Contrast Measurement Condition	10
6.5 Image Streaking	11
6.6 Display Cell Defect Specification	12
6.7 Luminance Variation Specification	13
6.8 Color Specification	14
6.9 Power Consumption	14
6.10 Gamma Characteristics	15
7. SOUND PRESSURE LEVEL SPECIFICATION	15
7.1 Measurement Condition	15
7.1 Sound Noise Level	15
8. MECHANICAL CHARACTERISTICS	16
8.1 Mechanical Specification	16
8.2 Mechanical Characteristics	16
9. ENVIRONMENTAL CONDITION	17
9.1 Absolute Maximum Ratings	17
9.2 Recommended Environment Condition	17
10. INTERFACE SPECIFICATION	18
11. POWER SPECIFICATION	22
12. MECHANICAL DIMENSION DRAWING	24
12.1 Front Side	24
12.2 Rear Side	24
13. LABEL	25
13.1 Label Type	25
13.2 Label Location	25
13.3 Serial No.	25
14. PACKING	27
14.1 Packing Dimension and Parts List	27
14.2. Packing Assy drawing	27



SamsungSDI Corporation

Specification

Plasma Display Module

15. RELIABILITY 29

15.1 MTBF29

15.2 Expected Service Life29

16. WARNINGS/ CAUTIONS / NOTICE.....30

16.1 Warning30

16.2 Caution.....30

16.3 Notice.....33

www.panelook.com

1. DESCRIPTION

The S50HW-XDxx is a 50-inch wide full color plasma display Module with a resolution of 1366(H) × 768(V) pixels. The display module includes the Plasma Display Panel(PDP), the Panel driving electronics, the Logic Control Board, and the SMPS(PSU) . PSU consists of two pieces of board (main supply & image board supply).

2. FEATURES

- Wide aspect ratio(16:9) 42 inch diagonal display screen. The display area is 1106.46mm wide and 622.08mm high.
- Slim and light weight. The display Module is 63mm(TBD) in depth and weight only approx.30.0kg exclusive of power supply.
- 16.77 million colors by combination of 8 bits R,G and B digital data
- High Luminance, High contrast, Wide viewing angle. The screen has a white peak Luminance of typical 1,000 cd/m²(TBD), contrast of typical 2,500:1(TBD) and a viewing angle (of) greater than 160° comparable to those of CRTs.

3. PRODUCT NAME AND MODEL NUMBER

- Product name : 50-inch Full Color Plasma Display Module3
(abbreviation : PDP Module3)
- Model number : S50HW-XDxx

4. FUNCTION OUTLINE

- The plasma display Module has an APC(Automatic Power Control) function which restricts power consumption within the certain value with regard to each display load ratio.
- The plasma display Module is operated by following digital video signals; Vertical synchronous signal, Horizontal synchronous signal, Enable signal and 8bits data signal of each R,G, and B color. All signals are based on LVDS level.
- The plasma display Module is operated at 50Hz or 60Hz frame rate. An external frame rate conversion is required in order to display the other formats.
- The plasma display Module requires 8 types of input power voltages; voltage for LOGIC, voltage for TCP driver IC, voltage for gate driver, voltage for sustain, erase, address, set and scan.
- The plasma display Module is operated at progressive signal only.
An external progressive scan conversion is required in order to display the other formats.
- The plasma display Module requires rated 100~240V, 50~60Hz of input power voltage. Maximum input voltage rating is AC 90~264V.



SamsungSDI Corporation

Specification

Plasma Display Module

5. BLOCK DIAGRAM

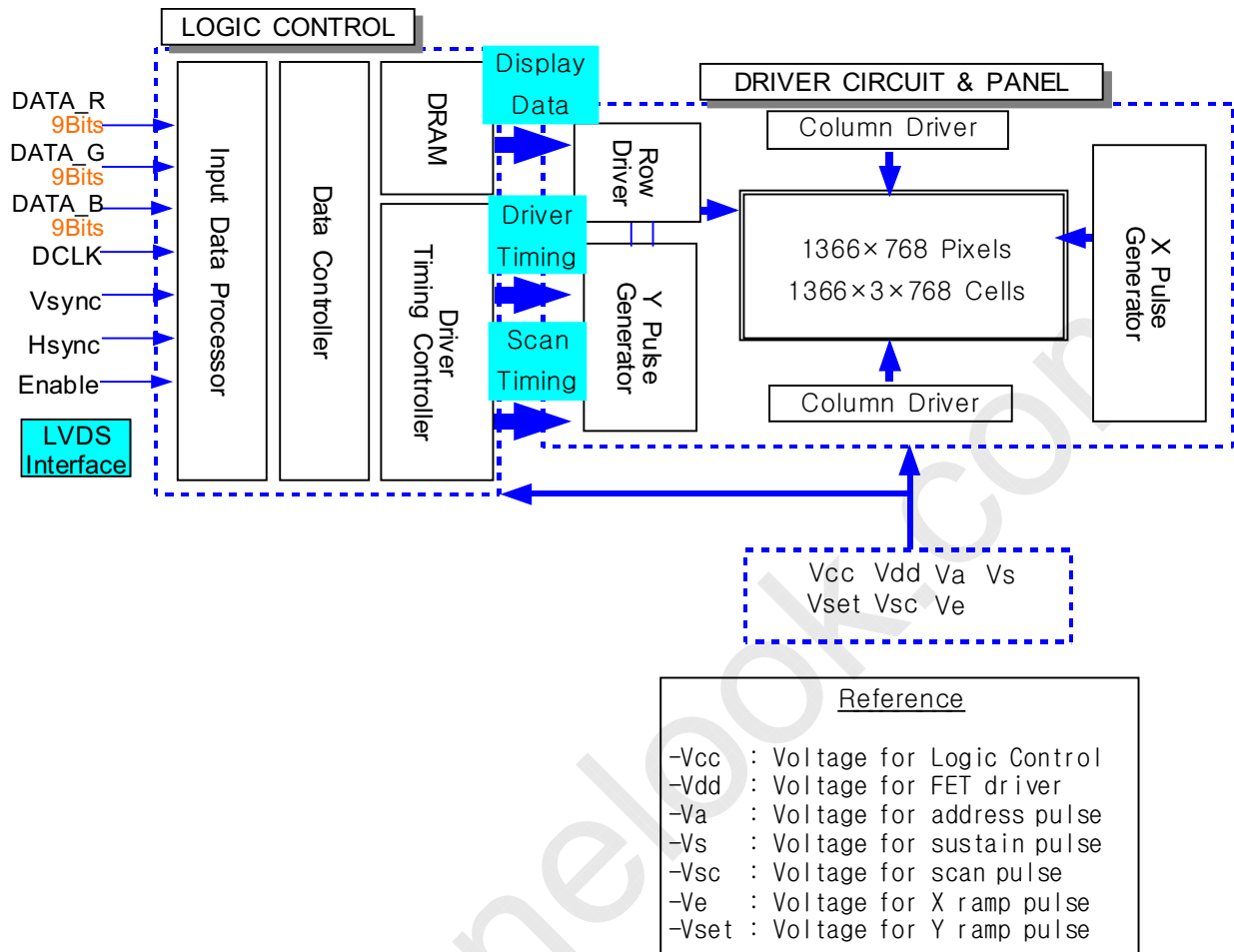

6. DISPLAY CHARACTERISTICS

6.1 Display Performance

No	Item	Rating	
1	Display Pixels	Horizontal 1366 × Vertical 768 pixels (1 pixel = 1 R,G,B cells)	
2	Display Cells	Horizontal 4,098 × Vertical 768 cells	
3	Pixel Pitch	Horizontal 810 μ m × Vertical 810 μ m	
4	Cell Size	R	Horizontal 270 μ m × Vertical 810 μ m
		G	Horizontal 270 μ m × Vertical 810 μ m
		B	Horizontal 270 μ m × Vertical 810 μ m
5	Pixel Type	R, G, B Matrix (refer to Figure-2)	
6	Effective Display Size	Horizontal 1106.46mm × Vertical 622.08mm	
7	Number of color	134.2million colors	
8	Peak Luminance *1	typical 1,000cd/m ² (NTSC_TBD)	
9	Contrast Ratio *2 (in dark room)	typical 2,500:1 (TBD)	Calculated value Refer to note *2
10	Color Coordinates (Typical value)	White : X= 0.285±0.020, Y= 0.290±0.020	
11	Viewing Angle *3	Over 160°	

(Note)

- * 1. Luminance and Color Coordinates are the values that were measured with 1% load ratio white pattern. The condition for measurement is shown in Figure-3.
- * 2. Contrast Ratio is calculated from the display Luminance and the non-display Luminance value. Display condition is shown in Figure-4.
- * 3. Viewing angle is a critical angle at which the Luminance is reduced to 50% to the Luminance perpendicular to the PDP Module. The Luminance is measured by a contact luminance meter CA-100(plus).

6.2 Display Cell Arrangement

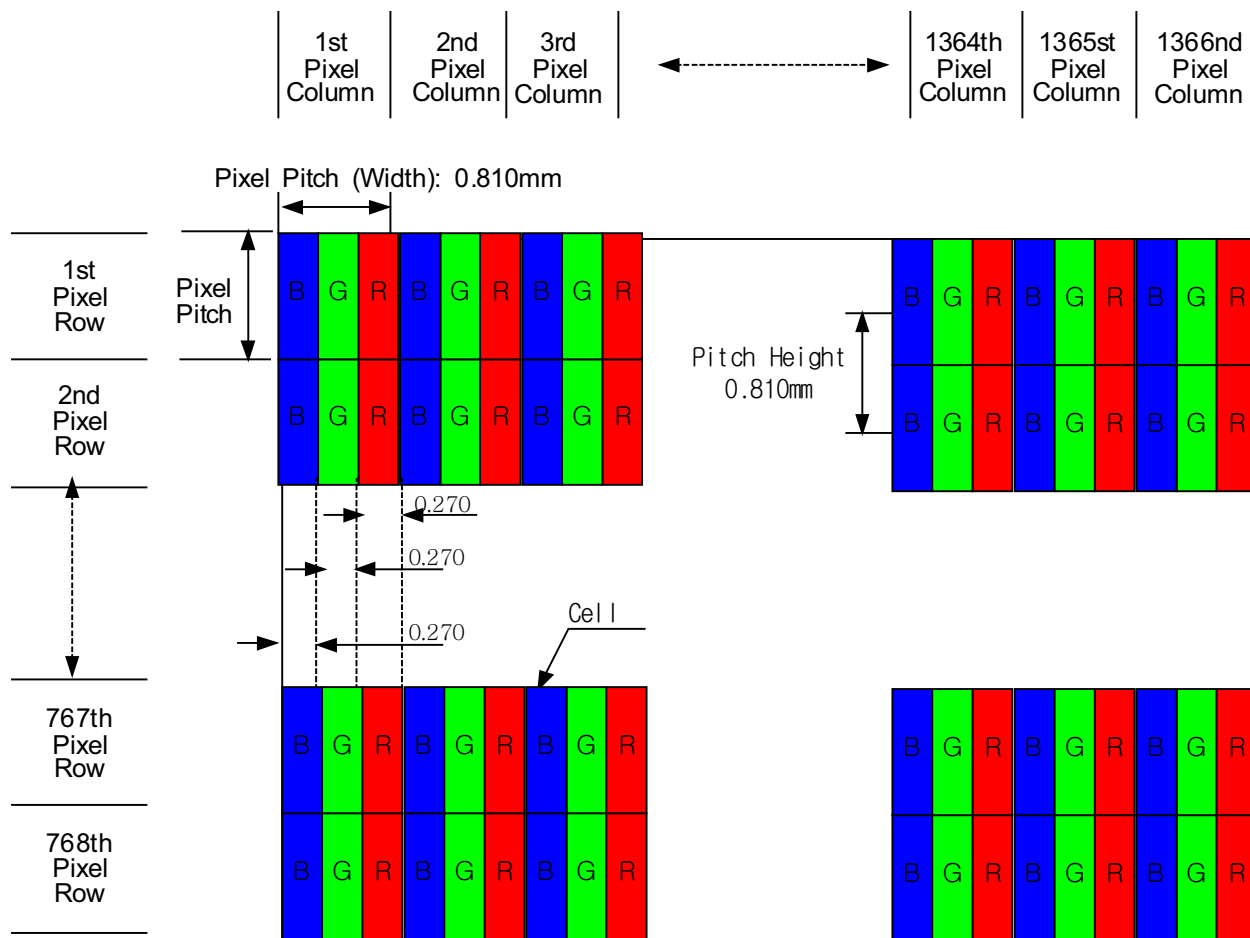
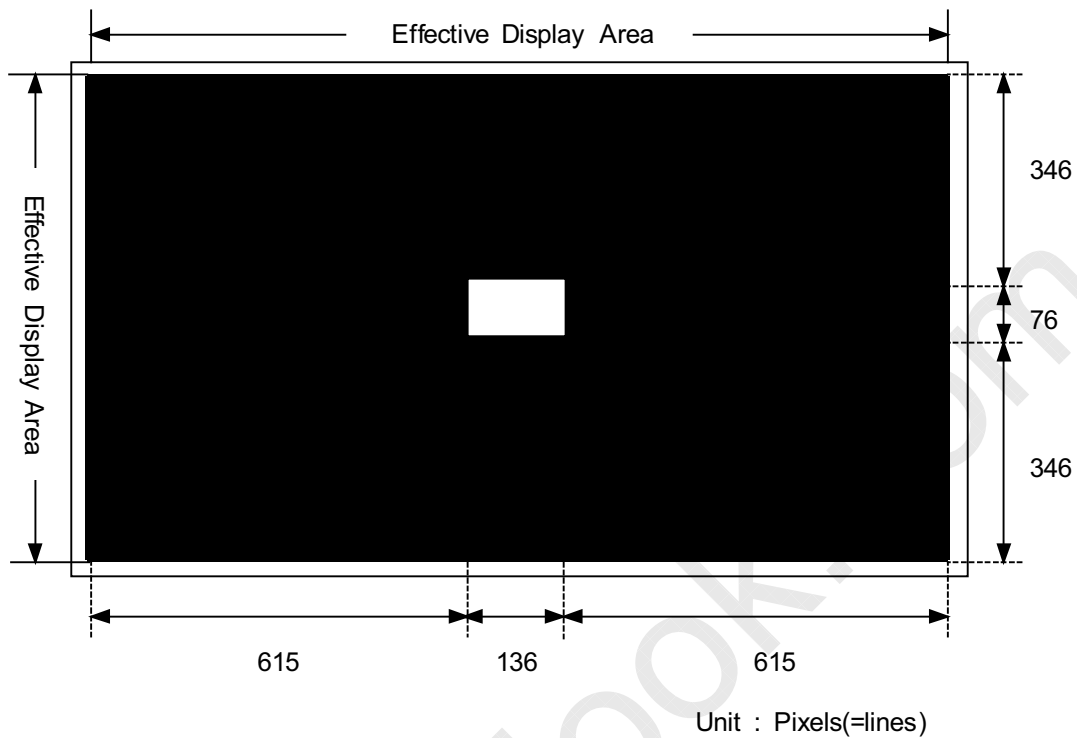

Figure-2. Display Cell Arrangement

6.3 Brightness Measurement Condition

(1) Display Pattern



- marked area : White display area by maximum gradation setting
- marked area : Black color (non-display area)

Figure-3. Display Pattern for Brightness & Contrast Ratio Measurement

- (2) Display Area ratio : 1% white window
- (3) Vsync : 16.7ms
- (4) Measuring equipment : MINOLTA CA-100 (Plus)
- (5) Ambient Temperature : Room Temperature
- (6) Ambient Luminance : Dark Room (<2 lux)

6.4 Contrast Measurement Condition

(1) Measuring point

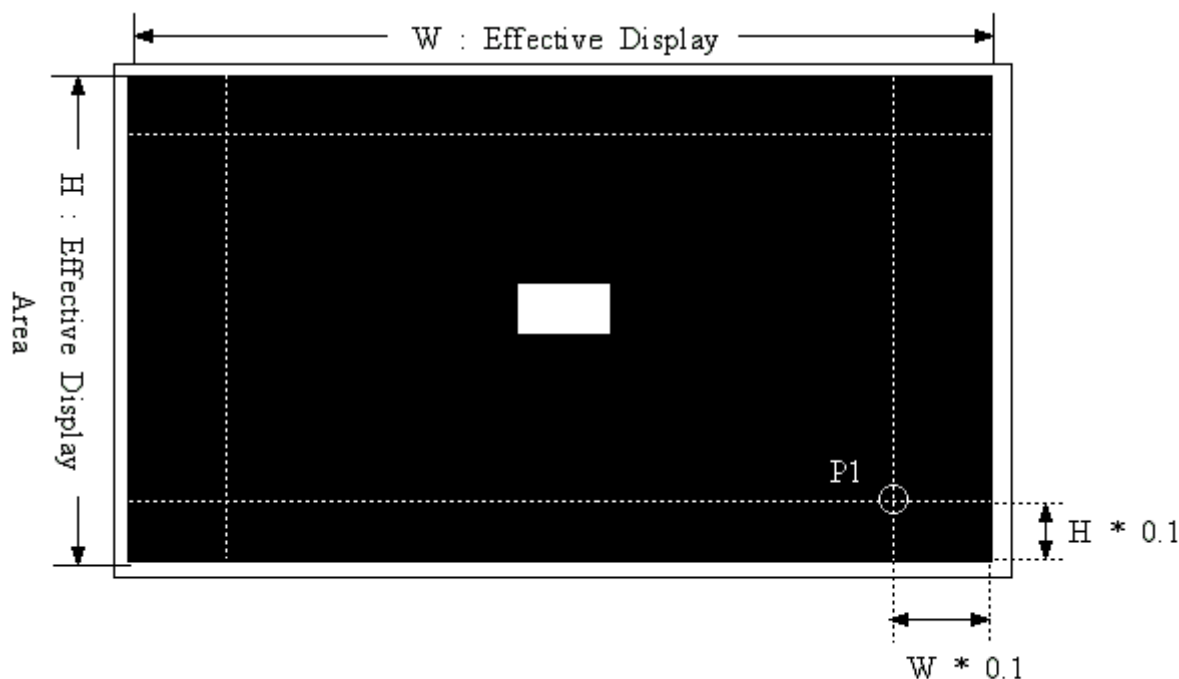

Figure-4. Measurement point

(2) Vsync : 16.7 ms

(3) Measuring Equipment : MINOLTA CA-100(plus)
Pattern Generator(VG-828, LVDS Output).

(4) Contrast Calculation formula

$$\text{Contrast ratio} = \frac{\text{Luminance of 1\% white window Area at the center of the screen}}{\text{Luminance of Black Area *1}}$$

【 Note 】

1. For mass production test purposes, it is recommended to measure just 1 point, P1 of Figure.-4 on display pattern of Fig.-3.

(5) Ambient Light : Dark Room (<2 lux)

6.5 Display Cell Defect Specification (TBD)

In some cases, a panel may have defective cells that cannot be controlled.

These defective cells can be categorized into three types;

- (1) Non-lighting cell defect : defect in which the cell is always off
- (2) Non-extinguishing cell defect : defect in which the cell is always on.
- (3) Flickering cell defect : defect in which the cell is flickering.
- (4) Test Pattern : Full White, Full Red, Full Green and Full Blue with 255 gray level.

The display cell defect specifications define the allowed limits for display cell defects and are used as the criteria in determining whether a panel should be shipped.

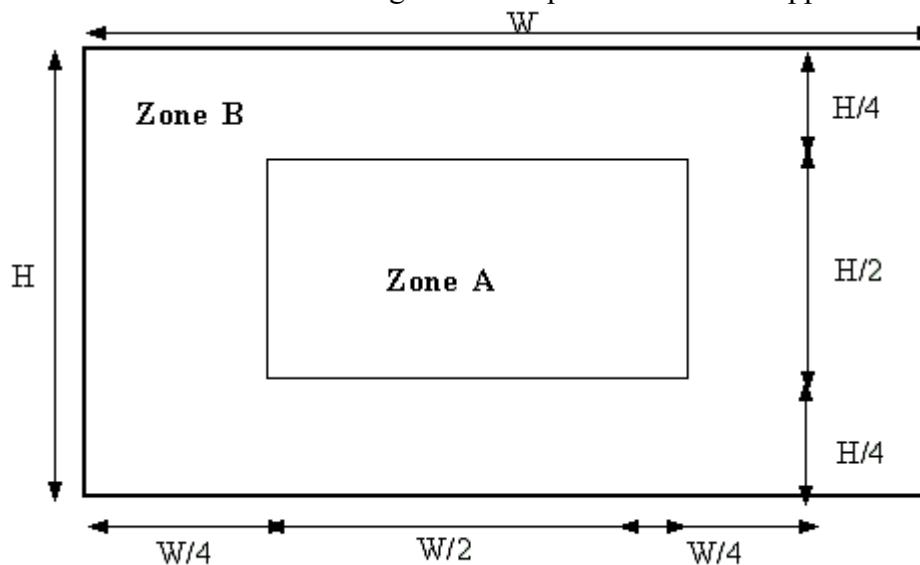

Figure-5. Measuring Area

Item	Specification
	Number of cell defects
Continuous Cell defect	<ul style="list-style-type: none"> ● Zone A: 1 and less ● Zone B: 1 and less
Non-lighting cell defect	<ul style="list-style-type: none"> ● Zone A: 4 and less ● Zone B: 10 and less
Non-extinguishing cell defect	<ul style="list-style-type: none"> ● Zone A: 1 and less ● Zone B: 3 and less
Flickering cell defect	<ul style="list-style-type: none"> ● Zone A: 1 and less ● Zone B: 3 and less
Total defect	Total number of cell defects in Zone A and B is 14 and less

6.6 Luminance Variation Specification

The color-PDP uses ultraviolet light produced by gas discharge to illuminate phosphor. Uneven phosphor coating and inconsistent discharge characteristics cause slight difference in Luminance among the sections in a panel.

Item	Definition	Specification
Full white brightness variation	The brightness is measured at 9 points (A1~A9 of Fig-6) on full white pattern. The full white brightness variation as then calculated from the following equations.	10% and less
Equation	$\frac{Max - \bar{x}}{\bar{x}} \times 100\% \quad \& \quad \frac{\bar{x} - Min}{\bar{x}} \times 100\%$	

The brightness variation specifications define the allowed limits for brightness differences and the criteria in determining whether a panel is shipped.

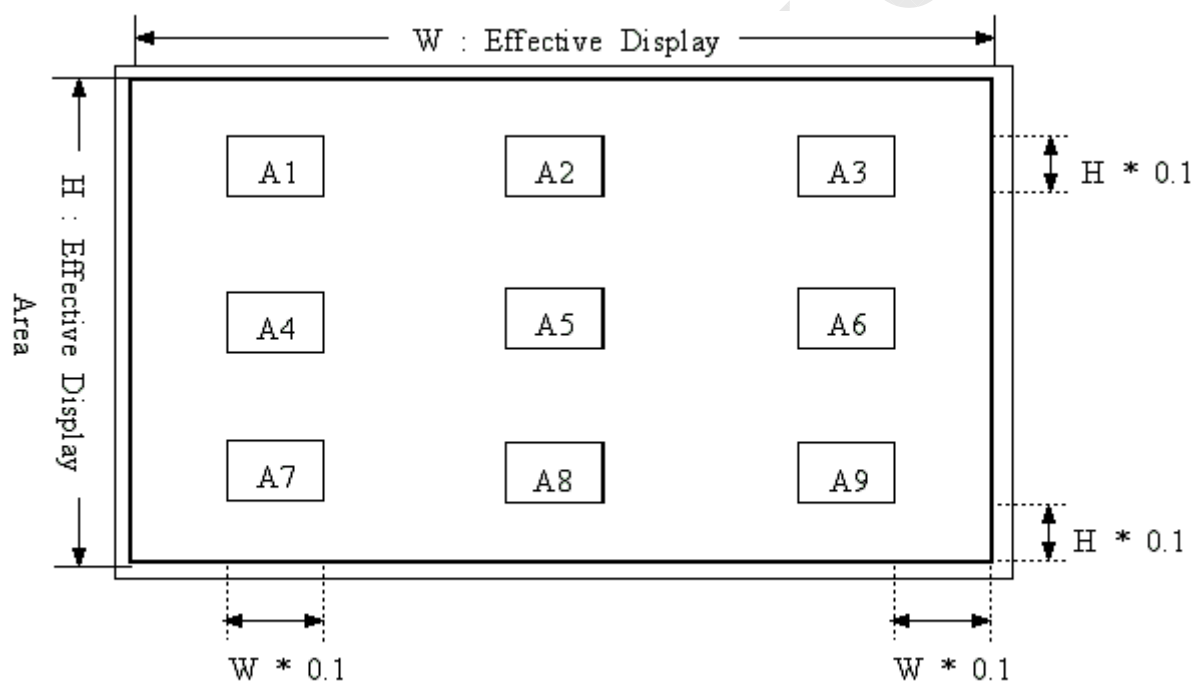

Figure-6. Measuring areas

6.7 Color Specification

The color-PDP displays a white color by mixing the lights produced by Red, Green, and Blue phosphor. This white color specification is defined by the following two categories based on chromaticity coordinates

Items	Chromaticity Coordinates *1)		Comments
	x	y	
Low Light (20IRE)	0.285 ±0.020	0.290 ±0.020	W/B Pattern *1)
High Light (57IRE)	0.285 ±0.020	0.290 ±0.020	

【 Notes 】

1. This specification is allowed among the PDP Modules.
See Figure-7. Measuring points are T1(High Light) and T2(Low Light).
2. This specification is allowed in a PDP Module.
It is measured at 9sections (A1~A9 of Figure-6) on a full white pattern
3. This specification is modifiable upon deliberation between **CUSTOMER** and SDI.

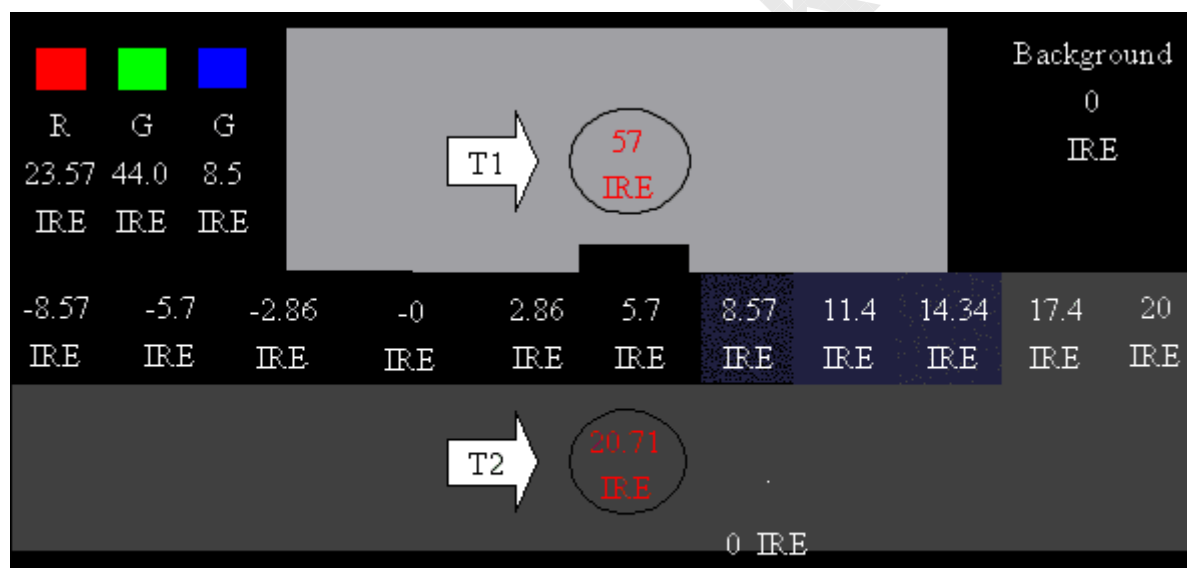

Figure-7. White Balance Tuning Pattern

6.8 Power consumption

(1) APC (Automatic Power Control) Function

The PDP has an APC (Automatic Power Control) function for the panel driver power source. If the total display load ratio exceeds approximately 11%, total power consumption will not exceed certain level. Measurement results below include SDI gamma function.

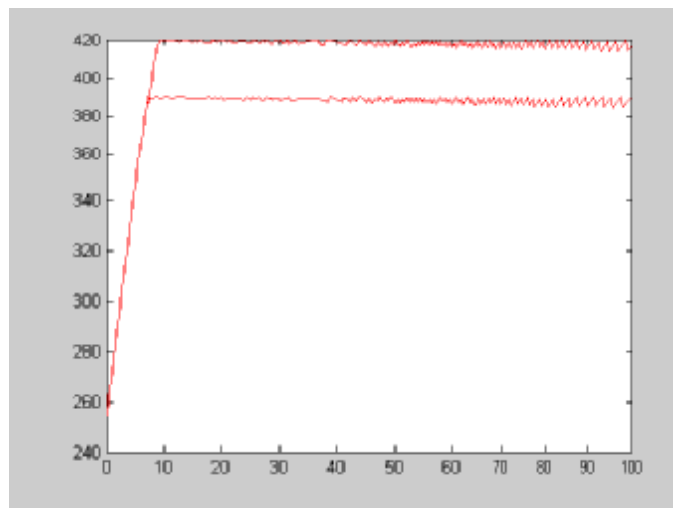

Figure-8. Display Load Ratio vs. power consumption

(2) Power consumption specification

Power consumption	Power sources
390 + 10%W and less	AC 120V, 220V 60Hz

【 Note 】

1. This is the case that the PDP Module includes SMPS made by Danam communications inc.
(Model : PS503D-REV**)
2. It is measured on a full screen white pattern.

6.9 Gamma characteristics

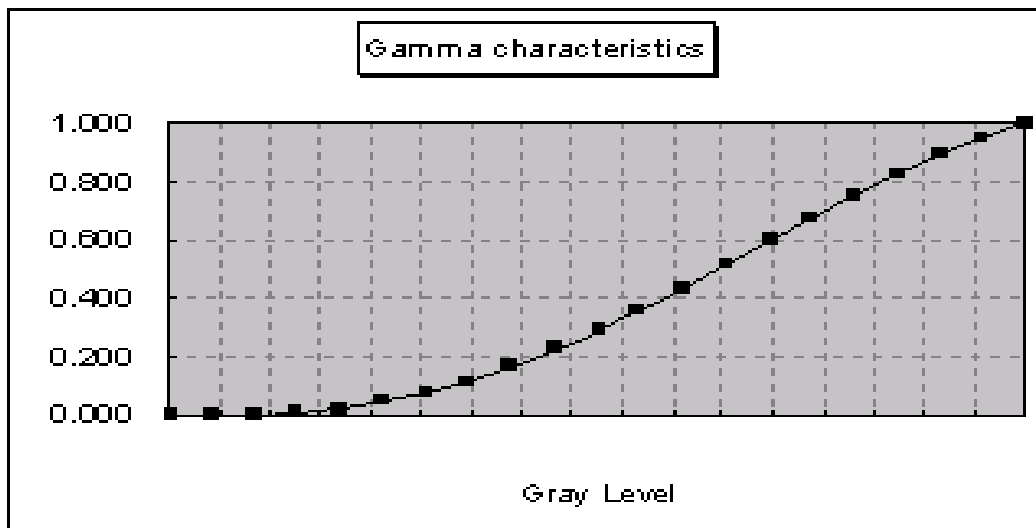

7. SOUND Noise LEVEL SPECIFICATION

7.1 Measurement Condition

- (1) Background Noise Level : less than 18dBA
- (2) Measuring Pattern : **Full Screen Full White**
- (3) Measuring Equipment : Sound level meter Type 2827 made by B&K
- (4) Measuring Distance : 50cm from the rear side of PDP Module
- (5) Measuring point

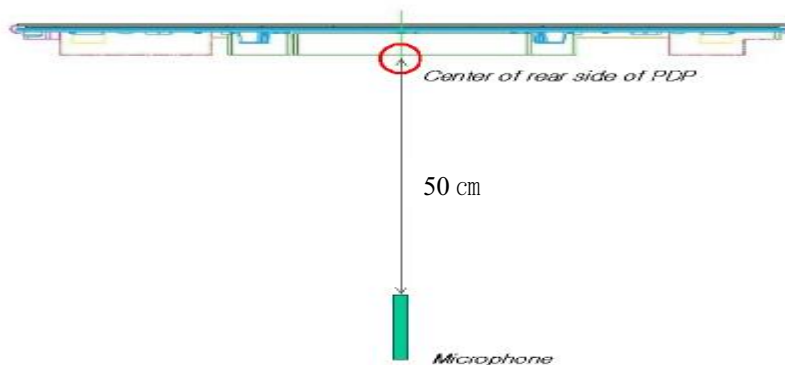

7.2 Sound Pressure Level : typical 32dB

- Frequency Range : 50Hz ~ 8kHz
- Bandwidth : $\frac{1}{3}$ Octave
- Weighting Filter : A-weighting network

【 Note 】

1. Sound Pressure Level is **the overall level** calculated from the individual band levels of 50Hz ~8kHz.
2. PSU must be included in this measurement.
3. The most noisy dynamic patterns are used in this measurement.

8. MECHANICAL CHARACTERISTICS

8.1 Mechanical Specifications

No	Item	Rating
1	Outer Dimensions	Width 1,184mm × Height 700mm × Thickness 63mm (include with TCP) *see Appendix (Mechanical Dimensions Drawing)
2	Weight	Approx. 30.0 kg (exclusive of power supply)

* Appendix A1 is included in section 12.1

* Appendix A2 is included in section 12.2.

8.2 Mechanical Characteristics

No	Item	Rating
1	Vibration	Frequency : 10 to 55Hz Sweep rate : 1 octave/min Stroke : x,y direction : 0.35mm z-direction : 0.175mm
2	Shock	Acceleration : less than 20G (X,Y-direction) less than 10G (Z-direction) Duration : 11 ms

* Notes: (Test condition) Non-Packaging, Operational (only for Vibration)

* Test time of Vibration Test is 30 minutes every direction(x,y,z)

* The number of times for shock test is 6 times every direction(x,y,z).

9. ENVIRONMENTAL CONDITIONS

9.1 Absolute Maximum Ratings

No.	Item	Rating	
1	Temperature	Operational	-0 to 65 °C
		Storage	-15 to 70 °C
		Temperature Slope	1.5 °C/minute max.
	* MAXIMUM GLASS SURFACE TEMPERATURE MUST BE KEPT LESS THAN 80 °C		
2	Humidity	Operational	5 to 85 % RH (no condensation)
		Storage	5 to 85 % RH (no condensation)
3	Pressure	Operational	700 to 1114 hPa (Altitude : 0 to 3,000 m)
		Storage	300 to 1114 hPa (Altitude : 0 to 9,000 m)

9.2 Recommended Environment Condition

No.	Item	Rating	
1	Temperature	Operational	0 to 50 °C
		Storage	-15 to 60 °C
		Temperature Slope	1.5 °C/minute max.
	* MAXIMUM GLASS SURFACE TEMPERATURE MUST BE KEPT LESS THAN 80 °C		
2	Humidity	Operational	20 to 70 % RH (no condensation)
		Storage	20 to 80 % RH (no condensation)
3	Pressure	Operational	800 to 1114 hPa (Altitude : 0 to 2,000 m)
		Storage	600 to 1114 hPa (Altitude : 0 to 4,500 m)

10. Interface Signal Specifications

10.1. Configuration Context

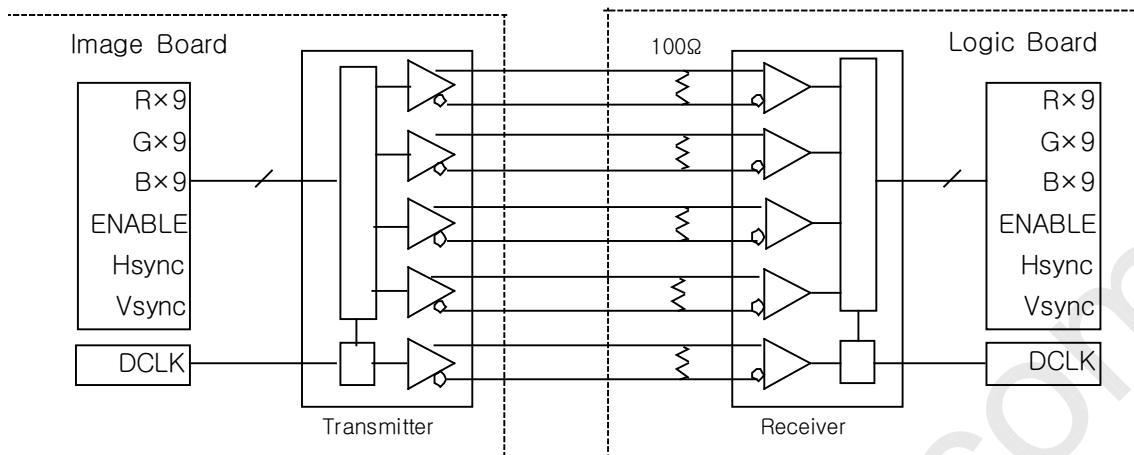

10.2. Timing of input signal

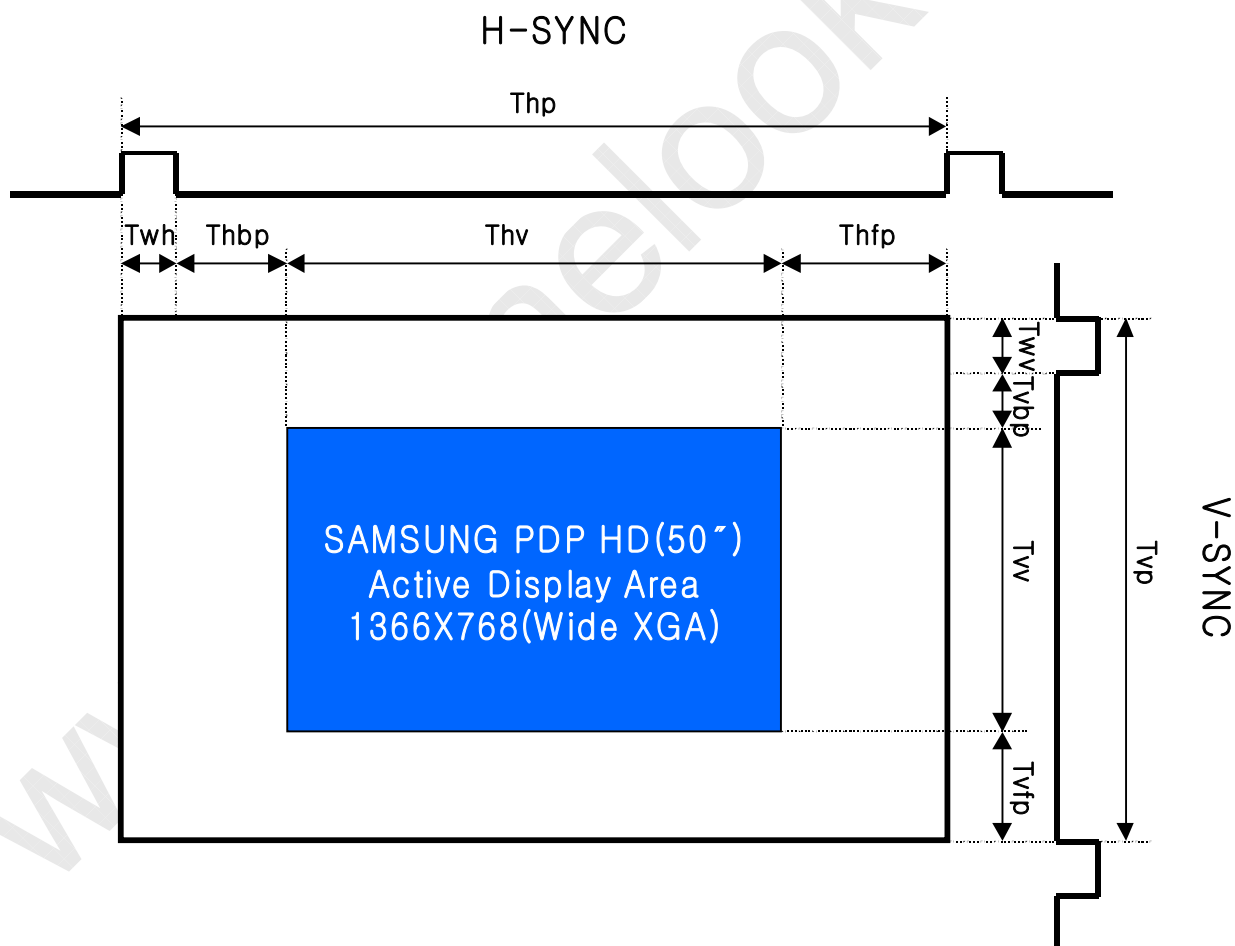

SamsungSDI Corporation

Specification

Plasma Display Module

■ NTSC

60Hz(NTSC)					
ITEM	Symbol		Typ	Unit	Note
DCLK	Period	Tclk	13.51	ns	
	Frequency		74	MHz	
Hsync	Period	Thp	1504	Tclk	
	Period		20.32	us	
Hsync	Frequency	Fh	49.20	KHz	
	Width	Twh	22	Tclk	
Vsync	Period	Tvp	820	Thp	
	Frequency	Fv	60	Hz	
Vsync	Width	Tww	6	Thp	
	Horizontal Valid	Thv	1366	clk	
DE	Horizontal Back Porch	Thbp	50	clk	
	Horizontal Front Porch	Thfp	66	clk	
(Data Enable)	Horizontal Blank		82	Thp-Thv	
	Vertical Valid	Tvv	768	H	
(Data Enable)	Vertical Back Porch	Tvbp	10	H	
	Vertical Front Porch	Tvfp	36	H	
(Data Enable)	Vertical Blank		52	Tvp-Tvv	

■ PAL

50Hz(PAL)					
ITEM	Symbol		Typ	Unit	Note
DCLK	Period	Tclk	13.51	ns	
	Frequency		74	MHz	
Hsync	Period	Thp	1504	Tclk	
	Period		20.32	us	
Hsync	Frequency	Fh	49.20	KHz	
	Width	Twh	22	Tclk	
Vsync	Period	Tvp	984	Thp	
	Frequency	Fv	50	Hz	
Vsync	Width	Tww	6	Thp	
	Horizontal Valid	Thv	1366	clk	
DE	Horizontal Back Porch	Thbp	50	clk	
	Horizontal Front Porch	Thfp	66	clk	
(Data Enable)	Horizontal Blank		82	Thp-Thv	
	Vertical Valid	Tvv	768	H	
(Data Enable)	Vertical Back Porch	Tvbp	10	H	
	Vertical Front Porch	Tvfp	200	H	
(Data Enable)	Vertical Blank		216	Tvp-Tvv	

SamsungSDI Corporation

Specification

Plasma Display Module

10.3. Timing Margin

구분		NTSC MODE			PAL MODE		
		min.	typ.	max.	min.	typ.	max.
DCLK	Frequency	76MHz	74MHz	72MHz	76MHz	74MHz	72MHz
	Period	13.16ns	13.51ns	13.88ns	13.16ns	13.51ns	13.88ns
Vsync	Frequency	58Hz	60Hz	65Hz	55Hz	50Hz	48Hz
	Period	15.38ms	16.67	17.24ms	18.18ms	20.00ms	20.83ms

10.4. LVDS Signal (Logic Board)

Interface Signal Function			
Symbol	I/O	Function	Remarks
RxIN0-	I	Display Data Signal: R2, R3, R4, R5, R6, R7, G2	LVDS signal
RxIN0+	I		LVDS signal
RxIN1-	I	Display Data Signal: G3, G4, G5, G6, G7, B2, B3	LVDS signal
RxIN1+	I		LVDS signal
RxIN2-	I	Display Data Signal: B4, B5, B6, B7, Hsync, Vsync, DE	LVDS signal
RxIN2+	I		LVDS signal
RxIN3-	I	Display Data Signal and Control Signal: R8, R9, G8, G9, B8, B9	LVDS signal
RxIN3+	I		LVDS signal
RxIN4-	I	Display Data Signal R1, G2, B1	LVDS signal
RxIN4+	I		LVDS signal
RxCLKIN-	I	Dot Clock Signal: CLK	LVDS signal
RxCLKIN+	I		LVDS signal

SamsungSDI Corporation

Specification

Plasma Display Module

10.5. Scaler Board/Logic Board LVDS Pin Definition

SCALER BOARD LVDS			Tx_Connector		Rx_Connector		LOGIC BOARD LVDS		
PIN No	PIN NAME	SIGNAL	PIN No	PIN Name	PIN No	PIN Name	PIN No	PIN NAME	SIGNAL
12	CLK IN	Dot Clock	1	N.C.	1	N.C.	31	CLK OUT	Dot Clock
33	TA0	R(2)	2	GND	2	GND	47	RA0	R(2)
34	TA1	R(3)	3	SDA	3	SDA	46	RA1	R(3)
35	TA2	R(4)	4	GND	4	GND	45	RA2	R(4)
36	TA3	R(5)	5	SCL	5	SCL	43	RA3	R(5)
37	TA4	R(6)	6	GND	6	GND	42	RA4	R(6)
38	TA5	R(7)	7	EMGY_OUT	7	EMGY_OUT	41	RA5	R(7)
40	TA6	G(2)	8	TxOUT4+	8	RxIN4+	40	RA6	G(2)
41	TB0	G(3)	9	TxOUT4-	9	RxIN4-	39	RB0	G(3)
42	TB1	G(4)	10	I2C_READY	10	I2C_READY	38	RB1	G(4)
44	TB2	G(5)	11	GND	11	GND	36	RB2	G(5)
45	TB3	G(6)	12	TxOUT3+	12	RxIN3+	35	RB3	G(6)
46	TB4	G(7)	13	TxOUT3-	13	RxIN3-	34	RB4	G(7)
48	TB5	B(2)	14	GND	14	GND	33	RB5	B(2)
49	TB6	B(3)	15	GND	15	GND	32	RB6	B(3)
50	TC0	B(4)	16	TxCLKOUT+	16	RxCLKIN+	29	RC0	B(4)
52	TC1	B(5)	17	TxCLKOUT-	17	RxCLKIN-	28	RC1	B(5)
53	TC2	B(6)	18	GND	18	GND	27	RC2	B(6)
54	TC3	B(7)	19	GND	19	GND	26	RC3	B(7)
55	TC4	HSYNC	20	TxOUT2+	20	RxIN2+	25	RC4	HSYNC
57	TC5	VSYNC	21	TxOUT2-	21	RxIN2-	24	RC5	VSYNC
58	TC6	EN	22	GND	22	GND	22	RC6	EN
59	TD0	R(8)	23	GND	23	GND	21	RD0	R(8)
61	TD1	R(9)	24	TxOUT1+	24	RxIN1+	20	RD1	R(9)
62	TD2	G(8)	25	TxOUT1-	25	RxIN1-	19	RD2	G(8)
63	TD3	G(9)	26	GND	26	GND	18	RD3	G(9)
64	TD4	B(8)	27	GND	27	GND	17	RD4	B(8)
1	TD5	B(9)	28	TxOUT0+	28	RxIN0+	15	RD5	B(9)
3	TD6	-	29	TxOUT0-	29	RxIN0-	14	RD6	-
4	TE0	R(0)	30	GND	30	GND	13	RE0	R(0)
5	TE1	R(1)	31	GND	31	GND	12	RE1	R(1)
6	TE2	G(0)	R0, G0, B0 => GND				11	RE2	G(0)
8	TE3	G(1)					10	RE3	G(1)
9	TE4	B(0)					8	RE4	B(0)
11	TE5	B(1)					7	RE5	B(1)
16	TE6	N.C.					6	RE6	N.C.
23	TCLK-	Dot Clock	TCLK- => TxCLKOUT- TCLK+ => TxCLKOUT+		RxCLKIN- => RCLK- RxCLKIN+ => RCLK+		56	RCLK-	Dot Clock
22	TCLK+						57	RCLK+	
31	TA-	R2~R7, G2	TA- => TxOUT0- TA+ => TxOUT0+		RxIN0- => RA- RxIN0+ => RA+		49	RA-	R2~R7, G2
30	TA+						50	RA+	
29	TB-	G3~G7, B2, B3	TB- => TxOUT1- TB+ => TxOUT1+		RxIN1- => RB- RxIN1+ => RB+		51	RB-	G3~G7, B2, B3
28	TB+						52	RB+	
25	TC-	B4~B7, HSYNC, VSYNC, DE	TC- => TxOUT2- TC+ => TxOUT2+		RxIN2- => RC- RxIN2+ => RC+		54	RC-	B4~B7, HSYNC, VSYNC, DE
24	TC+						55	RC+	
21	TD-	R8, R9, G8, G9, B8, B9	TD- => TxOUT3- TD+ => TxOUT3+		RxIN3- => RD- RxIN3+ => RD+		59	RD-	R8, R9, G8, G9, B8, B9
20	TD+						60	RD+	
19	TE-	R0, R1, G0, G1, B0, B1	TE- => TxOUT4- TE+ => TxOUT4+		RxIN4- => RE- RxIN4+ => RE+		61	RE-	R0, R1, G0, G1, B0, B1
18	TE+						62	RE+	

LOGIC LVDS CONNECTOR : FH12-40S-0.5SH

11. Input Power Voltage Specification

11.1. Input Power Connector Location

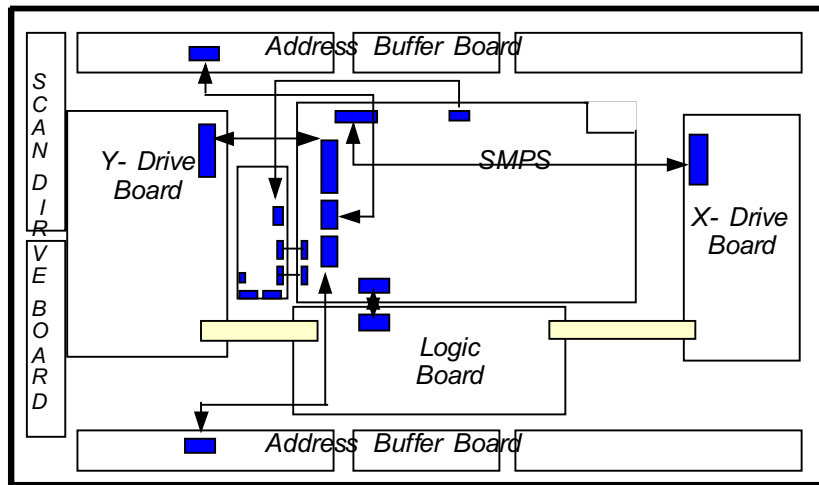

[Note]

1. Layout Schematic is viewed from back side of PDP Module.
2. The Output Power for Image board is separated from Main SMPS.
3. The Power for Image board is output by DC link Voltage boosted through PFC.
4. The Input Power Connector in Y-Drive Board is named as "SY".
5. The Input Power Connector in X-Drive Board is named as "SX".
6. The Input Power Connector in Logic Board is named as "SL".
7. The Input Power Connector in Address Buffer Board is named as "BUFFER"..

11.2. Power specification

Power Name	Voltage(V)	Current(A)	Regulation(%)	Ripple & Noise (V _{pp} , mV)	Remarks
Vs	170	3.0	±5	1000	Sustain voltage
Va	70	2.5		500	Address voltage
15Vg	15	1.5		100	Drive gate in FET
D5VL	5	3.0		50	Drive TTL in X,Y driving, Logic
D3V3	3.3	3.0		50	Drive IC in Logic
5Vsb	5.1~5.15	2.0		50	

[Note]

1. Above voltage levels are nominal value. They are adjustable to drive Panel.

11.3 Detail Power Specification of SMPS

SamsungSDI Corporation

Specification

Plasma Display Module

11.3.1 DC outputs for Logic Board

Connector No.	Output Name	Nominal Voltage	Load Current(A)			Variable Range(V)	Remarks
			Min.	Max.	Peak.		
CN8008	D3V3	3.3V	0.2	-	3.0	2.8~3.8	
	D5VL	5V	-	-	2.0	4.5~5.5	
	Vs_on	3.0V	-	-	-	-	Active High
CN8006 CN8005	Va	70V	0.2	1.2	2.5	60~75	

11.3.2. DC outputs for Driving Board(X,Y)

Connector No.	Output Name	Nominal Voltage	Load Current(A)			Variable Range(V)	Remarks
			Min.	Max.	Peak.		
CN8002 CN8003	D5VL	5V	0.2	-	1.0	4.5~5.5	
CN8002 CN8003	15Vg	15V	0.1	1.0	1.5	14~16	
CN8002 CN8003	Vs	170V	0.1	2.5	3.0	160~180	

11.3.3 DC outputs for Image Scaler Board

Connector No.	Output Name	Nominal Voltage	Load Current(A)			Remarks
			Min.	Max.	Peak.	
CN9003	VT	33V	0	-	0.01	
CN9003	12Vamp	12V	0.3		2.5	
CN9004	D12V	12V	0.1		0.6	
CN9003	A12V	12V				
CN9004	D6V	6V	0.1		1.0	
CN9003	A6V	6V	0.1		1.0	
CN9004	D3V3	3.3V	0.1		1.5	

11.4 Power Applying Sequence



Relay on

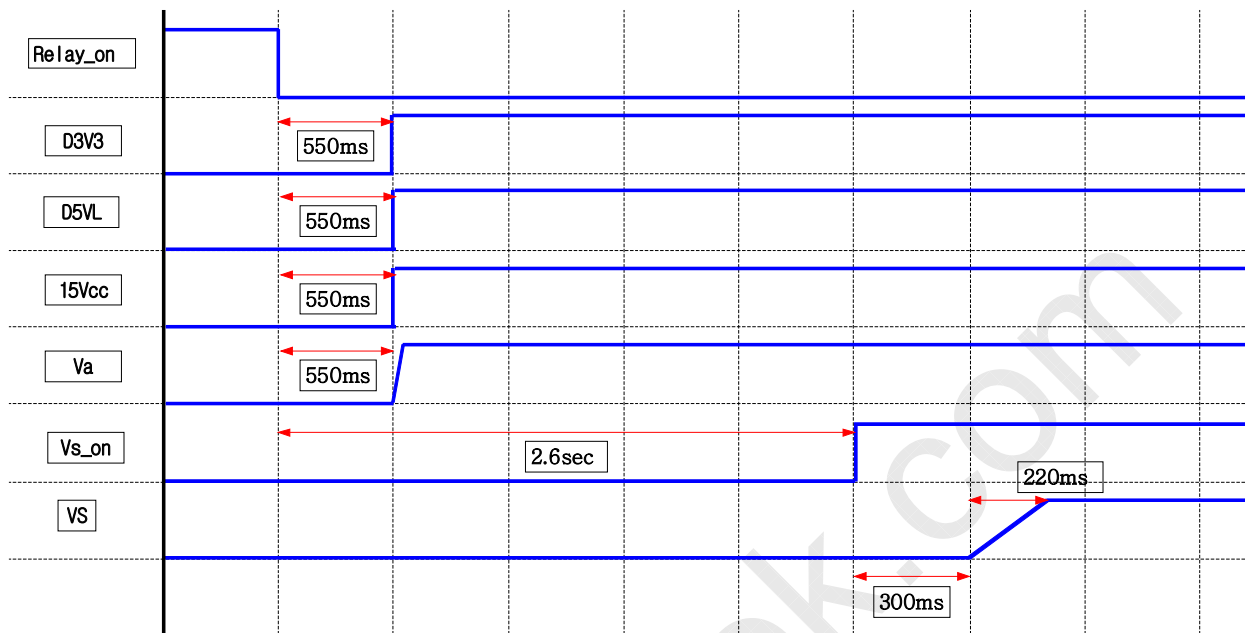

Relay off

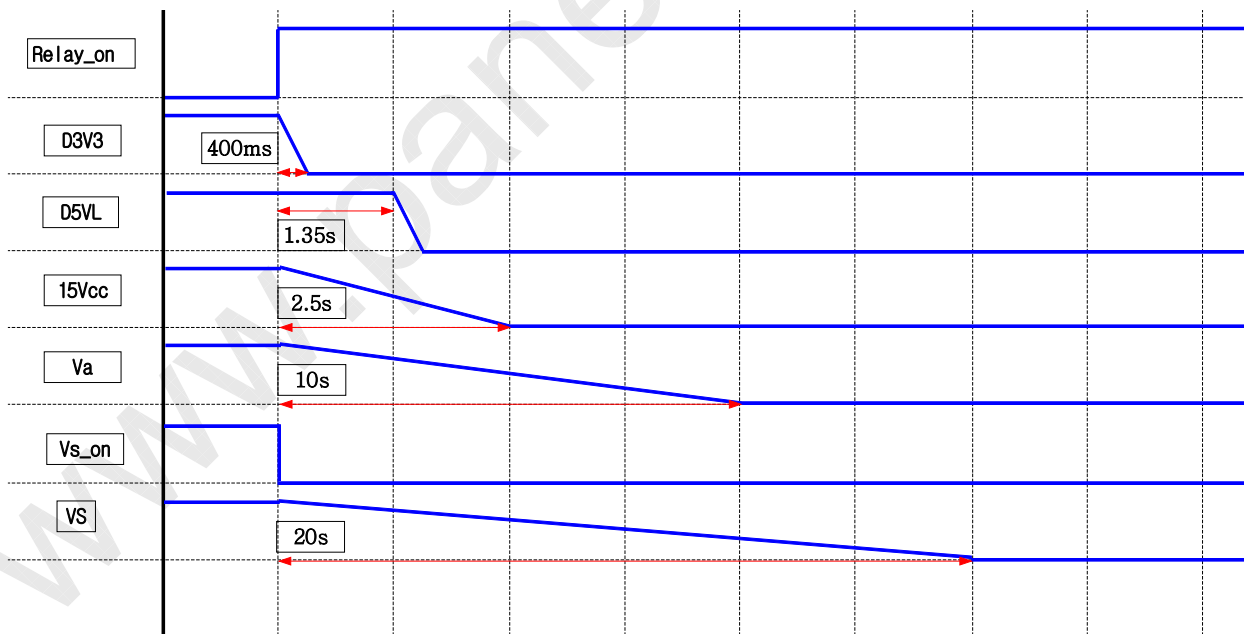

SamsungSDI Corporation

Specification

Plasma Display Module

Relay off(1sec) ~ on

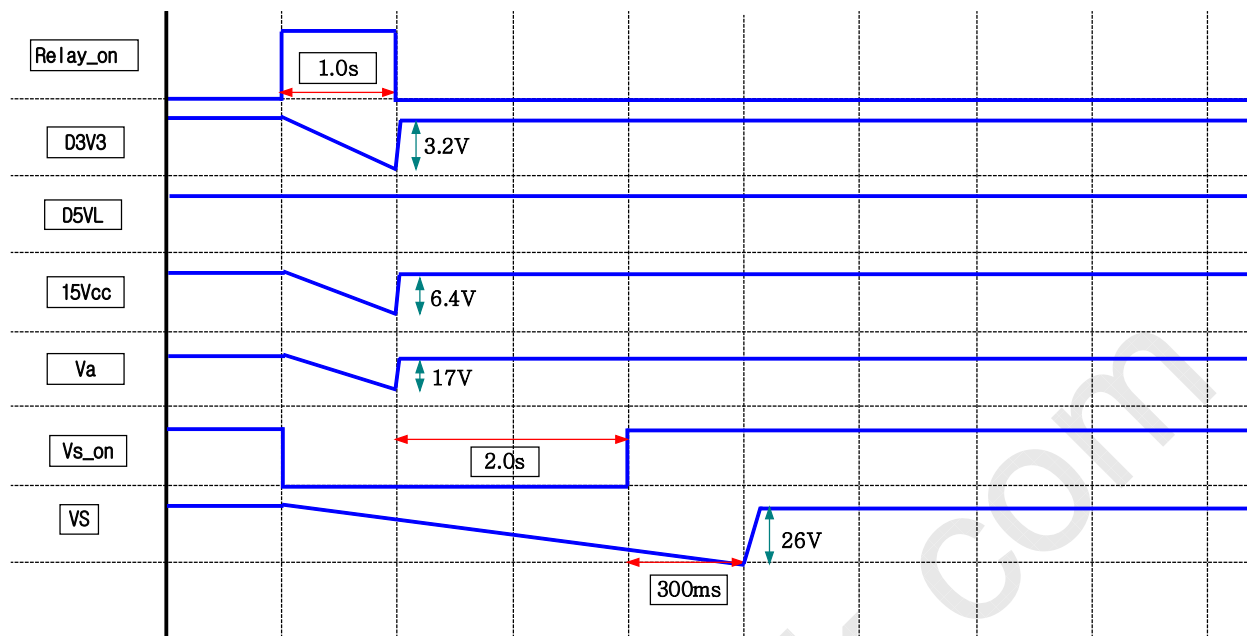

AC off(1sec) ~ on

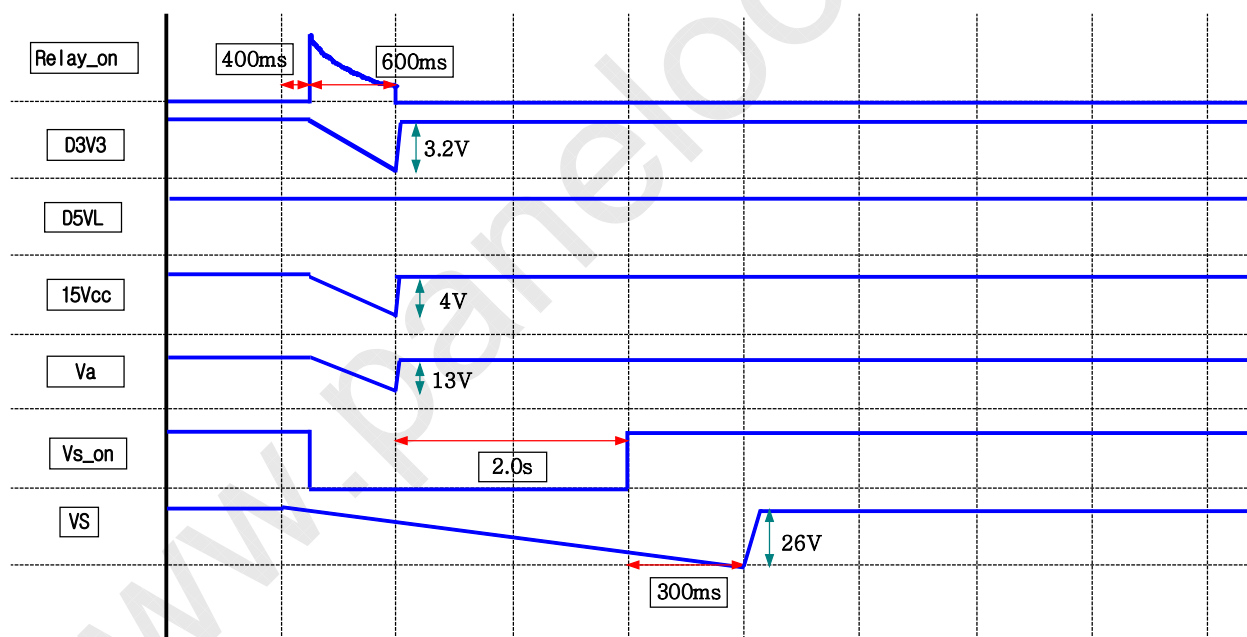

SamsungSDI Corporation

Specification

Plasma Display Module

11.5 Pin assignment of connectors for Power Supply

11.5.1 Power MAIN BOARD Output Connector & Pin Assignment

Location Num.	CN8001	CN8002	CN8003	CN8004	CN8005 CN8006	CN8007	CN8008	CN8009
Function	AC Input	X Drive	Y Drive	Interface	Address Buffer	Interface	Logic	DC_LINK
Pin Num.	3 Pin	9 Pin	10 Pin	13 Pin	5 Pin	12 Pin	10 Pin	5 Pin
Connector Type	JST B2P3-VH	Molex 35313-0910	Molex 35313-1010	Molex 35312-1310	Molex 35313-0510	Molex 35312-1210	Molex 5267-1010	Molex 35313-0510
Pin No.	Pin Name	Pin Name	Pin Name	Pin Name	Pin Name	Pin Name	Pin Name	Pin Name
1	AC Line	D5VL	D5VL	Relay	Va	VSB	D3V3	PFC
2	N.C	Vg	Vg	Panel_Powe	Va	GND	D3V3	N.C
3	AC Netural	GND	GND	GND	N.C	THEM.DET	GND	0V
4		GND	NC	N.C	GND	GND	GND	0V
5		NC	GND	IV-4	GND	NC	D5V	DC-Vcc
6		GND	NC	GND		GND	GND	
7		GND	GND	IV-3		GND	VSB	
8		Vs	GND	GND		PIRQ	Relay	
9		Vs	Vs	IV-2		N.C	Vs_on	
10			Vs	GND		N.C	GND	
11				IV-1		N.C		
12				GND		N.C		
13				NC				

SamsungSDI Corporation

Specification

Plasma Display Module

11.5.2 IMAGE BOARD Output Connector & Pin Assignment

Location Num	CN9002	CN9003	CN9004	CN9005	CN9006	CN9007
Function	FAN	-	-	DC-LINK	Interface	Interface
Pin Num.	3 Pin	10 Pin	11 Pin	5 Pin	12 Pin	13 Pin
Connector Type	Molex 35312-0310	Molex 35313-1010	Molex 35313-1110	Molex 35312-0510	Molex 35313-1210	Molex 35313-1310
Pin No.	Pin Name	Pin Name	Pin Name	Pin Name	Pin Name	Pin Name
1	FAN12V	A6V	D6V	PFC	VSB	Relay
2	GND	GND	GND	NC	GND	Panel power
3	NC	A12V	D3V3	0V	THEM.DET	GND
4		GND	D3V3	0V	GND	NC
5		VAMP	GND	DC_VCC	NC	IV-4
6		VAMP	GND		GND	GND
7		GND	D12V		GND	IV-3
8		GND	Relay		PIRQ	GND
9		VT	GND		N.C	IV-2
10		GND	VSB		N.C	GND
11			Them.det		N.C	IV-1
12					N.C	GND
13						N.C

11.6 MECHANICAL REQUIREMENTS

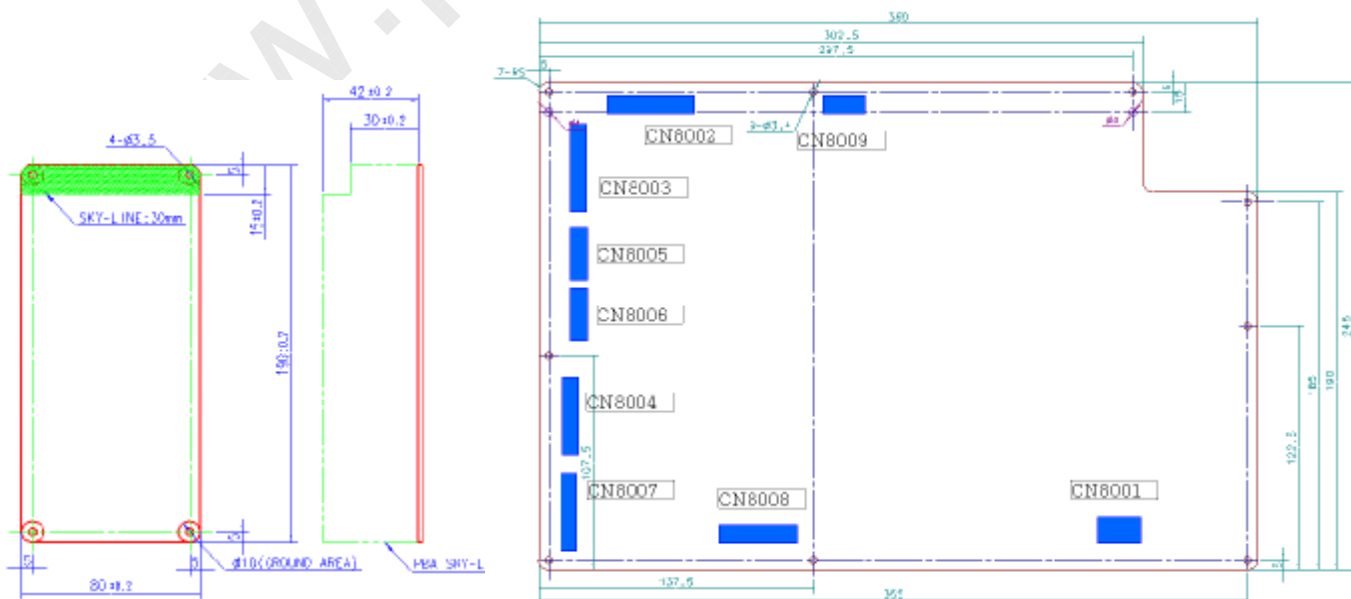



12. Mechanical dimension drawing

12.1. Mechanical Dimensions Drawing Front side

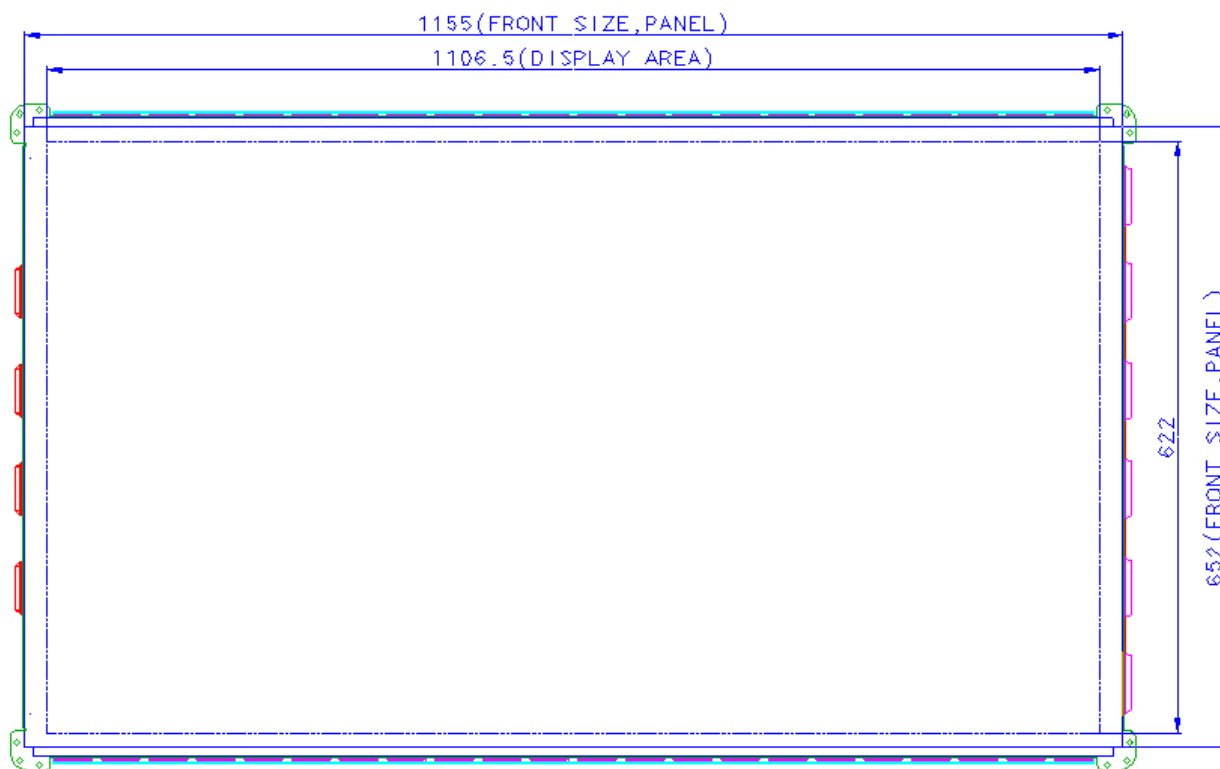

12.2. Mechanical Dimensions Drawing Rear side

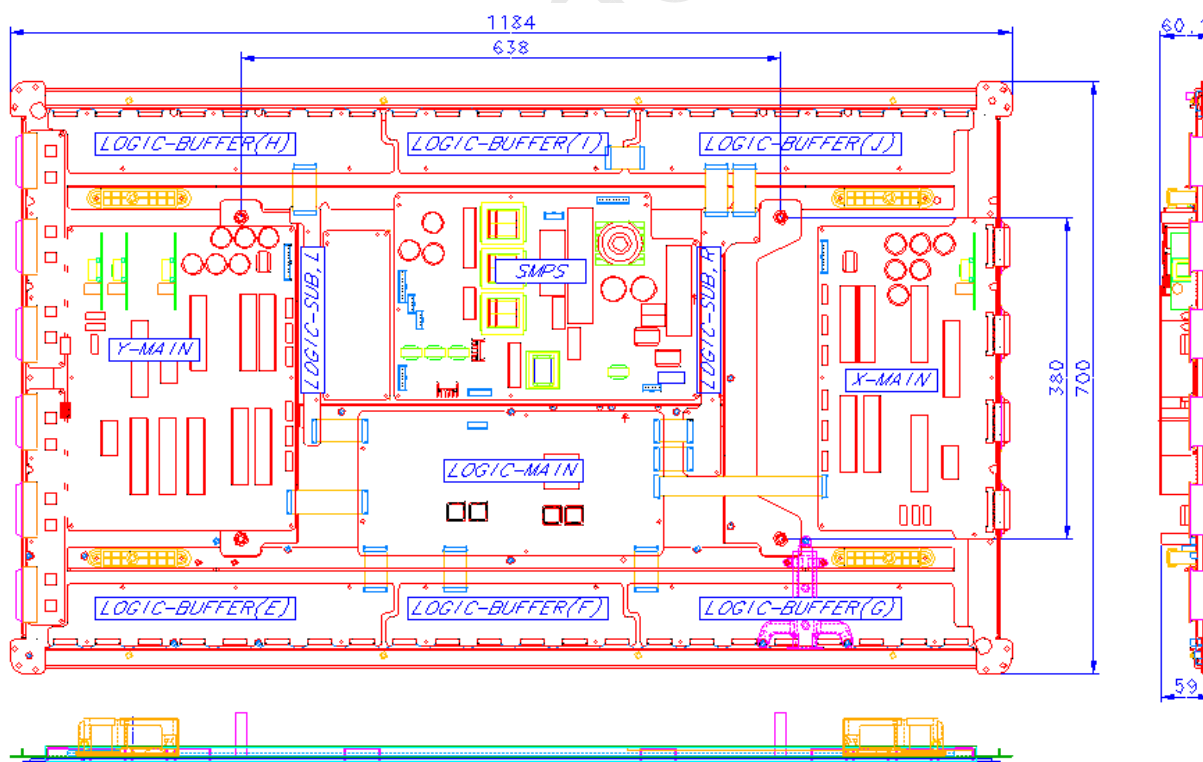

13. LABEL(To be updated)

13.1 Label type

- (1) Label for the PDP Module
(To be Updated)

- (2) Label for power specification

<input type="checkbox"/> NTSC		<input type="checkbox"/> NTSC/PAL		
Va	Vsc	Vs	Ve	Vset
70	-60	170	150	160
Rev 1.0				

Reference

- Vsc : Voltage for Display driver
- Vset : Voltage for Display driver
- Vs : Voltage for Display driver
- Ve : Voltage for Display driver
- Va : Voltage for Column driver

13.2 Label location (TBD, To be updated)

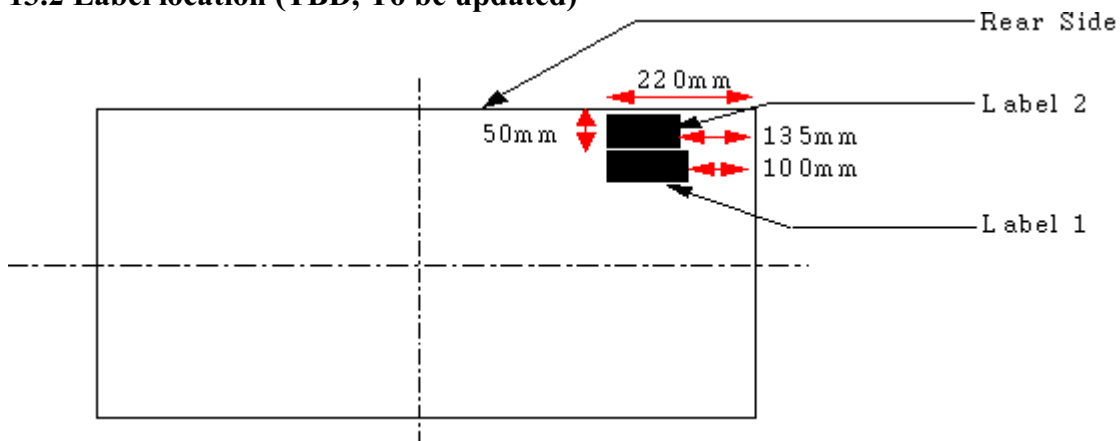

【 Notes 】

1. Label-1 is a label for the PDP Module.
2. Label-2 is a label for the power specification.

13.3 Serial No.

2 6 1 3 0 7 0 5 0 0 0 1

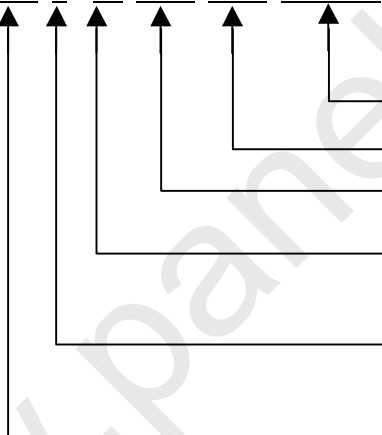

Serial No : 0001~9999
Date : 01~31
Month : 01~12
Year : 00(2000) ~99(2099)
Line No : 1 ~ 9 (0:Pilot Line)
Type : 02~48 (ex.50HD:26) (Step of even)



SamsungSDI Corporation

Specification

Plasma Display Module

14. Packing

14.1 Packing Dimension and Parts List

- Number of Module in 1 package: 5 Modules
- Packing dimensions (W*L*H): 1465*760*1106 (mm) (Including Pallet :136mm)
- Weight: About 140 ± 5 (Kg)

No.	Parts	Specification	Q'ty	Remarks
1	Bag LDPE	W1300,L950,T0.07	1,000	
2	Silicagel(DRY-PAK)	100g	2,000	
3	Cover-Module(P/W10)	L1251,W791,H79.3	200	
4	Washer	IDØ8.5,ODØ35,2T	4,000	
5	Screw,Machine	PH,+,M8,L25	4,000	
6	Pallet	L1465,W760,H136	200	
7	Packing-Cover-Top	L1477,W722,H155	200	
8	Packing-Cover-Bot	L1417.W662,H165	200	
9	Cushion,Bottom	50HD,EPP,V3,TCP,C=0.022	400	
10	Cushion-Top	50HD,EPP,V3,TCP,C=0.022	400	
11	Band,PE	T1,W18mm	800M	
12	Band,Clip,Locker	SPL,18mm,T0.35	800	
13	Guide,Pack	L1465,D50,T5	400	
	Module 2			



14.2 Packing Assay drawing

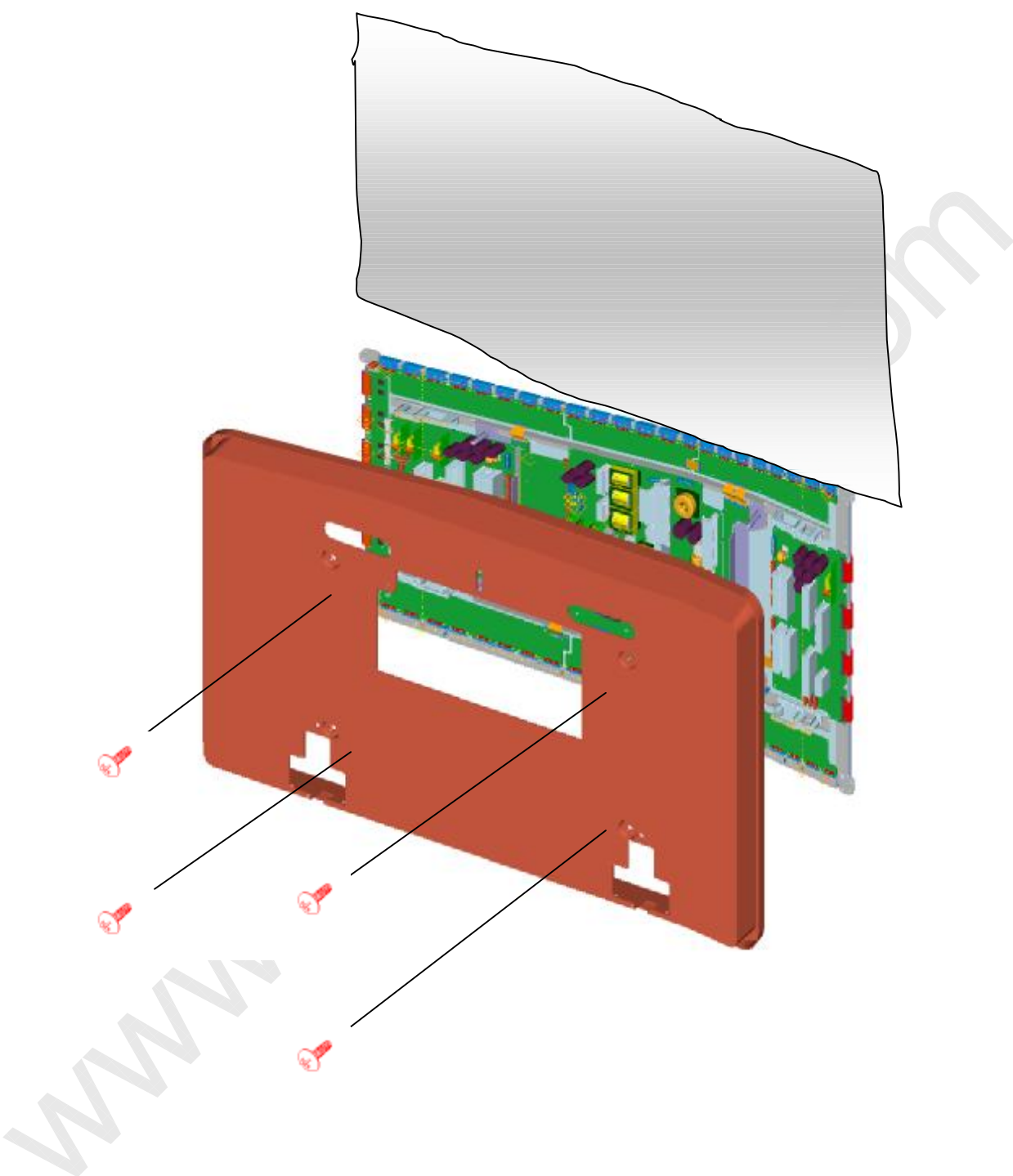



SamsungSDI Corporation

Specification

Plasma Display Module

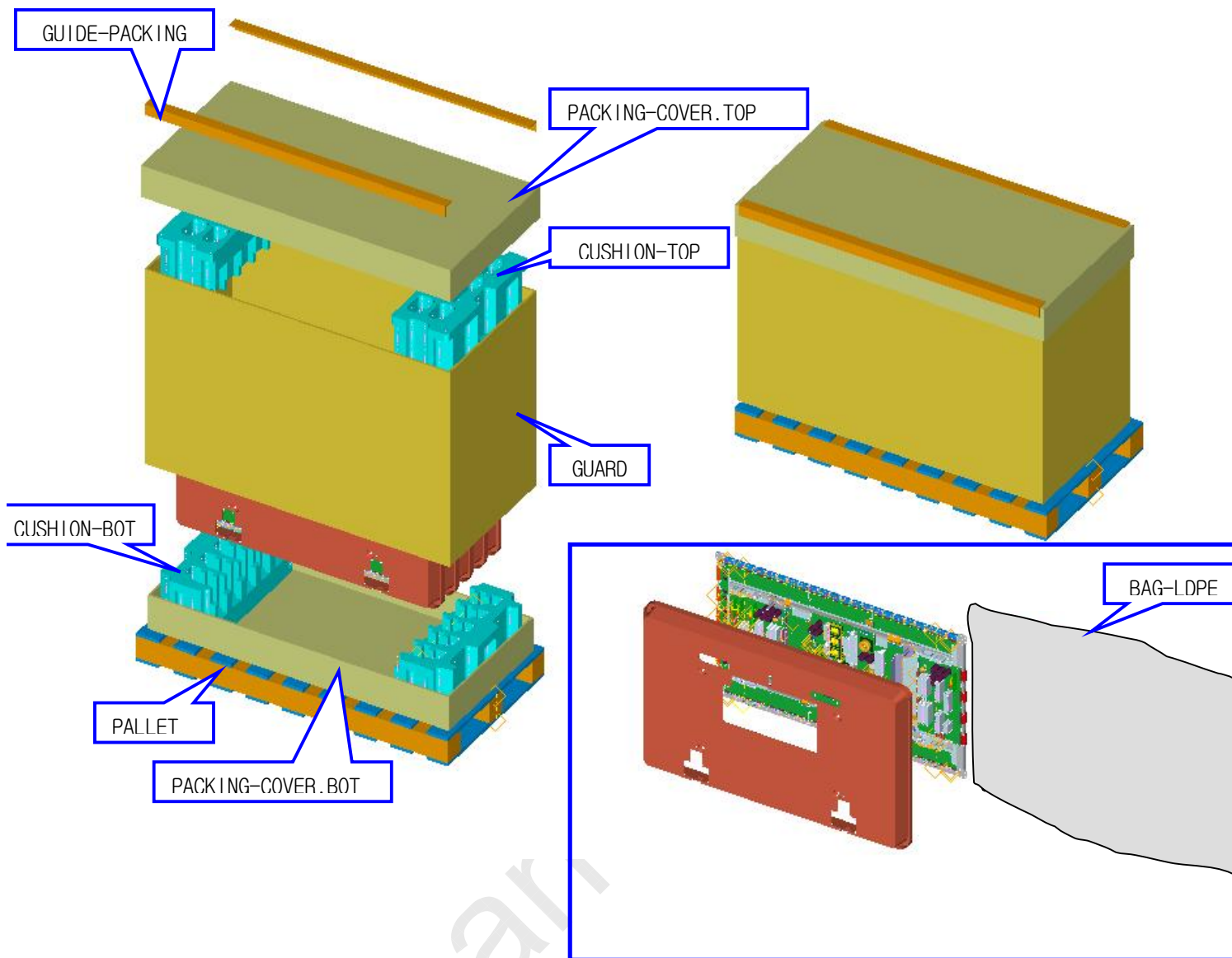

14.3. Inspection Tag.

(1) Type (For example)

 INSPECTION TAG			
LOT NO.		MAT. No	
		TYPE NO.	
P/O NO.		<i>CUSTOMER</i>	
Q'ty		CUSTOMER MAT. CODE	
REMARK			

(2) Location

Inspection Tag of Front and Rear side is located as Figure-10.

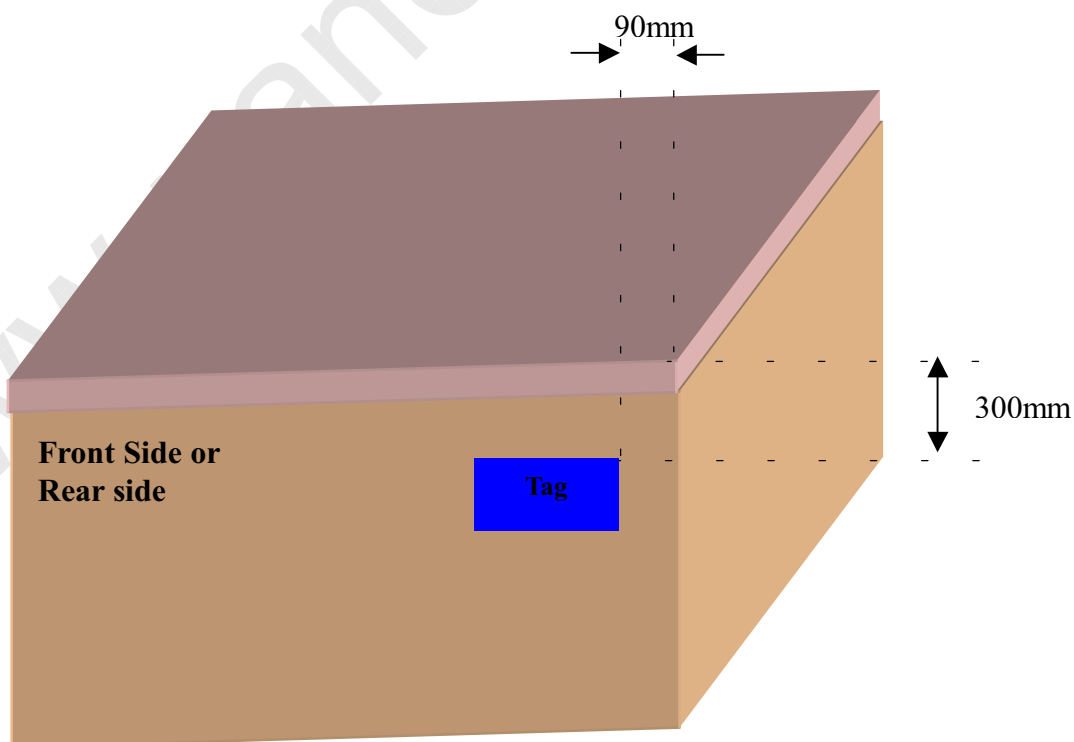



15.RELIABILITY

15.1 MTBF

Mean Time Between Failure is dependent on overall PDP monitor design.

MTBF : 20,000 hours (Environmental temperature : 25°C)

※ Condition : 25°C, Used moving Picture Signal

15.2 Expected Service Life

#1. Definition

The expected service life is defined by the following two categories. And the life time is defined by the reached time either (1) or (2).

(1) The white color brightness level becomes half (50%) of its initial value, which is determined by the phosphor characteristics.

(2) The number of display cell defects increases to double of the specification, which is depending on the discharge characteristics.

#2. Test condition and life time

The expected service life time differs with display conditions as below.

(1) Full screen white color display

Life time : 30,000 hours

(2) Test condition : 8 Hours / Day

16. WARNING / CAUTION / NOTICE

TO PREVENT POSSIBLE DANGER, DAMAGE, AND BODILY HARM, PLEASE CONSIDER AND OBSERVE ALL WARNINGS AND CAUTIONS CONTAINED IN THIS PARAGRAPH.

16.1 Warning

If you do not consider the following warnings, it could result in death or serious injury

- (1) The S50HW-XDxx Module is controlled by high voltage about 350V. If you need to handle the Module during operation or just after power-off, you must take proper precautions against electric shock and must not touch the drive circuit portion and metallic part of S50HW-XDxx Module within 5 minutes.
The capacitors in the drive circuit portion remain temporarily charged even after the power is turned off. After turning off the power, you must be sure to wait at least one minute before touching the Module. If the remain voltage is strong enough, it could result in electric shock.
- (2) Do not use any other power supply voltage other than the voltage specified in this product specifications. If you use power voltage deviated from the specifications, it could result in product failure.
- (3) Do not operate or install under the deviated surroundings from the environmental specification set for the below; in moisture, rain or near water-for example, bath tub, laundry tub, kitchen sink; in a wet basement; or near a swimming pool; and also near fire or heater - for example, near or over radiator or heat resistor; or where it is exposed to direct sunlight; or somewhere like that. If you use the S50HW-XDxx Module in places mentioned above, it could result in electric shock, fire hazard or product failure.
- (4) If any foreign objects (e.g. water, liquid and metallic chip or dust) entered the S50HW-XDxx Module, the power supply voltage to the S50HW-XDxx Module must be turned off immediately. Also, never push objects of any kind into the S50HW-XDxx Module as they may touch dangerous voltage point or make short circuits that could result in fire hazard or electric shock.
- (5) If smoke, offensive smell or unusual noise should come from the S50HW-XDxx Module, the power supply voltage to the S50HW-XDxx Module must be turned off immediately.
Also, when the S50HW-XDxx screen fails to display any picture after the power-on or during operation, the power supply must be turned off immediately. Do not continue to operate the S50HW-XDxx Module under these conditions.
- (6) Do not disconnect or connect the S50HW-XDxx Module's connector while the power supply is on, or immediately after power off. Because the S50HW-XDxx Module is operated by high voltage, and the capacitors in drive circuit remain temporarily charged even after the power is turned off. If you need to disconnect or reconnect it, you have to wait at least one minute after power off.

SamsungSDI Corporation**Specification****Plasma Display Module**

- (7) Do not disconnect or connect the power connector by a wet hand. The voltage of the product may be strong enough to cause an electric shock.
- (8) Do not damage the power cable of the S50HW-XDxx Module, also do not modify it.
- (9) When the power cable or connector is damaged or frayed, do not use it.
- (10) When the power connector is covered with dust, please wipe it out with a dry cloth before the power on.

16.2 Caution

If you do not consider the following cautions, it may result in personal injury or damage facilities.

- (1) Do not set the S50HW-XDxx Module on an unstable place, vibrating place and inclined place. The S50HW-XDxx Module may fall or collapse, and it may cause serious injury to a person, and serious damage to the product.
- (2) If you need to remove the S50HW-XDxx Module to another place, you must turn off the power supply and detach the interface cable and power cable from the S50HW-XDxx Module beforehand, and watch your steps not to step on the cables during the operation. If the cables are damaged during the transport, it may result in fire hazard or electric shock. Also if the S50HW-XDxx Module is dropped or fallen, it may cause a serious injury to a person.
- (3) When you draw or insert the S50HW-XDxx 's cable, you must turn off the power supply and do it (with) holding the connector. If you forcibly draw the cable, the electric wire in the cable can be exposed or broken. It may result in fire hazard or electric shock.
- (4) When you carry the S50HW-XDxx Module, it should be done with at least two workers in order to avoid any unexpected accidents.
- (5) The S50HW-XDxx Module has a glass-plate. If the S50HW-XDxx Module is inflicted with excessive stress - for example; shock, vibration, bending or heat-shock, the glass plate could be broken. It may result in a personal injury. Also, do not press or strike the glass surface.
- (6) If the glass panel was broken, do not touch it with bare hand. It may result in a cut injury.
- (7) Do not place any object on the glass panel. It may be the cause of the scratch or break of the glass panel.
- (8) Do not place any object on the S50HW-XDxx Module. It may result in a personal injury due to fall or drop.

16.3 Notice

When you apply the S50HW-XDxx Module to your system or handle it, you must make sure to follow the notices set forth below.

□ Notice to your system design

- (1) The S50HW-XDxx Module radiates the infrared rays of between 800 and 1000nm. It may bring an error in operating the IR-remote controller or another electric system. Please consider (to) providing the IR absorb filter in your system, and evaluating it.
- (2) The S50HW-XDxx Module has a high-voltage switching circuit and a high-speed clock circuit. Therefore, you have to apply and evaluate the EMC consideration of your system.
- (3) The S50HW-XDxx Module has a glass plate. In your mechanical design, please (consider to) avoid any excessive shock and stress to the glass surface. Also be careful not to damage the tip-tube at the corner of glass plate. If the glass plate and tip-tube are **damaged**, the S50HW-XDxx & Module may fail.
- (4) In your system, for your safety, please have the remaining voltage of the S50HW-XDxx Module leaked immediately after power-off.
- (5) As the S50HW-XDxx Module generates heat during operation, please make sure the well-radiation and well-ventilation are provided for your system design. The S50HW-XDxx Module may be defected by the usage out of the specified ambient temperature.
- (6) The ventilation design in your system should have a back-cover that is able to prevent moisture and dust from getting into the inside of the electric circuit, because the S50HW-XDxx Module has high-density electric parts with high-voltage. If the driver circuit has condensation or dusts, it may cause a short circuit or dielectric breakdown.
- (7) If the S50HW-XDxx Module displays a fixed pattern on the screen for an extended period of time, it could make the differences in Luminance and chromaticity between fixed pattern area and other areas. It is because the Luminance of the fixed pattern area becomes lower than the other areas due to the **degradation** of the phosphor, but this phenomenon is not a failure.
On the other hand, when the display pattern is changed, the **illuminated** areas may maintain their Luminance temporarily (for few minutes). This phenomenon is a characteristic from color S50HW-XDxx itself due to the activation of the discharge surface in the S50HW-XDxx panel, which is normal. If you have an intention of displaying the fixed pattern, the screen-saver **technique** should be applied to your systems in order to minimize the image retention.
- (8) The S50HW-XDxx Module is not intended for the equipments **that** require extremely high reliability such as aerospace equipments, nuclear control systems or medical equipments for life support.
- (9) Based on the requirements of the **safety** standard (UL, EN etc.), be sure to add the filter that come up to the impact test to the glass plate.

□ Notice to the operation and handling of the S50HW-XDxx Module.

- (1) To prevent defect or failure, please check the cable connections and power-supply condition before power-on.
- (2) The S50HW-XDxx Module is controlled by high voltage. Not only during operation but also immediately after power-off, do not disconnect or reconnect the S50HW-XDxx Module's connector because it may result in failure. If you need to disconnect or reconnect, you have to wait at least one minute after power-off.
- (3) The S50HW-XDxx Module is equipped with various protection circuits that automatically stop the Module operation, if an interface signal or the power voltage becomes abnormal during operation. If the S50HW-XDxx Module stops suddenly during operation, please check the conditions of input signal or power source before restarting.
- (4) For the protection of the circuit, if an abnormal situation is occurred, the high output voltage will be shut down by (watching) the internal input voltage (V_s / V_a / V_{cc}).
In this case, the Module power resetting is necessary to recover.
There are also fuses in the V_s and V_a power supply system to prevent smoking and firing by the excessive current. The protecting function of the address driver of keeping a supervisory device for the internal current is provided in the V_a power supply system. Therefore, the number of sub-frames decreases to a proper value when the I_a current exceeds a constant value occasionally.
- (5) If an abnormal situation such as disconnecting of the input connector occurs, this Module will be on stand-by, which the supply of high output voltage is stopped even if an external power is being supplied. If a normal signal is inputted after this, normal operation state, operations can be restarted again by re-inputting a normal signal. However, it is necessary to rest the Module power when t_{VH} and/or t_{HV} are less than the minimum value provided in the specification
- (6) To ensure reliable operation of the S50HW-XDxx Module and to protect it from overheating, do not wrap or cover it with a cloth or like a sheet during power-on period. Also, do not place the S50HW-XDxx Module in a confined space or any other places of poor ventilation.
- (7) If you continue to watch the naked S50HW-XDxx screen(without filter glass) for a long time, your eyes could be fatigued. We recommend you rest your eyes occasionally.
- (8) The S50HW-XDxx screen is controlled with the display-data signals and synchronized signals. If noise interferes with those signals, the S50HW-XDxx screen could become unstable and, in some case, would cause a failure. Do not place any equipment that generates excessive EMI/RFI noise near the interface cable of the S50HW-XDxx Module, and keep the cables as short as possible.
- (9) Be careful not to break the glass panel when you handle the S50HW-XDxx Module. Also, when handling the S50HW-XDxx Module, you must wear gloves or other hand protection to prevent injuries that can occur in case when the glass panel is broken.
- (10) The glass panel section and drive circuit section of the S50HW-XDxx Module are closely connected and they function as a pair. If the Module is arbitrarily recombined,

SamsungSDI Corporation**Specification****Plasma Display Module**

restructured, or disassembled, SDI will not be responsible for the function, quality, or operational integrity of the modified Module. Do not recombine, restructure, or disassemble it.

(only, the Module for A/S is allowed to be recombined, restructured, or disassembled.)

- (11) To avoid a possible electric shock, you must make sure that the power supply voltage of S50HW-XDxx Module is turned off before cleaning. To clean the S50HW-XDxx 's glass panel, apply water or a natural detergent to a piece of soft cloth or gauze, and wring the cloth tightly before wiping the screen. Make sure that no water comes in contact with the connecting terminals on the side of the glass panel. Do not use chemical solvents, such as paint thinner or benzene, to clean the glass panel.
- (12) The drive circuit section of S50HW-XDxx Module uses C-MOS integrated circuits that must be protected from static electricity. Therefore when transporting or delivering the Module, be sure to put the Module in an antistatic bag. When handling the S50HW-XDxx Module, take adequate grounding precautions to prevent static electricity.
- (13) When delivering or transporting the S50HW-XDxx Module, you must take special precautions because excessive vibration or shock should not be applied to it. If the Module is dropped, or (if) excessive vibration/shock is applied, the glass panel of the S50HW-XDxx Module may be broken and the drive circuit may be damaged. The packing for delivering or transporting should be made with strict instructions.
- (14) When storing the S50HW-XDxx Module, you must select an environmentally controlled place. Avoid any environment in which the temperature or humidity exceeds the specification values. If you are storing it for a long period of time, We recommend that you place the Module together with a dehumidifying agent, such as silica gel, in a moisture-proof bag and keep it in an environmentally controlled place.
- (15) The S50HW-XDxx Module is composed of various kinds of materials such as glass plate, metals and plastics. A qualified service technician is required for the disposal of the S50HW-XDxx Module.

□ Notice of the S50HW-XDxx Module performance

The S50HW-XDxx Module is the newest display device utilizing the gas discharge technology and digital signal processing technology, and its performances are mostly similar to those of CRT. However, some display performances of the S50HW-XDxx - ****Module are different from the CRT's. Please consider the following notices when you watch the S50HW-XDxx screen.

- (1) There is (a) slight Neon luminance shown outside of the effective display area on the glass panel. Conceal this part so that it may not be seen on the display surface.
- (2) Depending on the type and time of usage, there may be a slight change in the Luminance and color. There may be an increase of both X-value and Y-value by 0.05 at the maximum in chromaticity. In this case, adjust it using the external data signal.
- (3) Because the S50HW-XDxx Module uses phosphor to emit a light, the phosphor, like a CRT, will be deteriorated in proportion to the display signal and Luminance settings. If the same pattern is displayed continuously (fixed display) for an extended period of time, the

SamsungSDI Corporation**Specification****Plasma Display Module**

Luminance of that area will be decreased over non-lit areas due to the fact that the discharge surface will be more activated comparing to the other areas.

- (4) When the Vsync signal timing becomes shorter right after the changing of Vsync frequency (e.g. from 50Hz to 60Hz / from 60Hz to 70Hz) depending on the Multi-Vsync function, an initial Vsync signal of the changed frequency will be disregarded and the S50HW-XDxx screen will be interrupted for 1 frame period in maximum.
- (5) Because the S50HW-XDxx Module is a digital processing display device, this Module is equipped with the Error diffusion technology and a Duplicated Sub-Frame method to display the grayscale and false contour improvement. However, you may sometimes find a color false contour, especially in human facial contour, in moving picture due to the difference of display performance comparing to the TV-tube.
- (6) If the S50HW-XDxx Module displays some video test patterns that are mostly used in a laboratory or inspection process of the manufacturing facilities, you may find the following subjects. But these subjects should not be recognized in the failure or defects because the display performance of the S50HW-XDxx Module is equipped with Error diffusion technology and Duplicated Sub-Frame method(for PAL) based on digital processing technique.
- <a> Linearity in the grayscale test pattern
If the S50HW-XDxx -****Module displays the grayscale test pattern (e.g. white color Luminance is gradually changed horizontally or vertically) in a screen, you may find the disparity of Luminance at adjacent grayscale patterns. This behavior is caused by duplicated sub-frame condition(for PAL), display load correction and electrode dependency.
- Color contouring and dithering at the stationary picture
If the stationary picture such as a human face or the like is shown in the S50HW-XDxx screen, you may feel some unstable noise at the contour area. This behavior is called the color contouring or dithering, and is caused by the error diffusion condition, display load correction and electrode dependency.
- (7) If the S50HW-XDxx Module is operated under inadequate conditions or harsh environment, the screen may become unstable or noisy. This instability is mostly related to ambient temperature, air pressure, input signal instability (include signal noise), input power voltage and strong magnetic field such as MRI/NMR application or superconducting magnet application. Please do not apply the S50HW-XDxx Module to inadequate conditions or harsh environment mentioned above.