

FOR MESSRS:

DATE : July 25, 2007

CUSTOMER'S SPECIFICATIONS (Approval)

126.9cm(50 Inch) Wide Plasma Display Module

MODEL : S50HW-YD04
(NTSC/PAL)

- * This specification will be approved by both Customer and Samsung SDI Co.,Ltd.
- * Please return one of this specifications with your signature for approval.

Proposed by:

Approved by:

Signature _____Signature _____

Vice President Sung Do, Kim

PDP Quality Innovation Team,

PDP Division, Samsung SDI Co., LTD

CONFIDENTIAL



SamsungSDI Corporation
Module

Specification

Plasma Display

Revision History

No.	Date	Description Of Changes	Rev. No	Approval



CONTENTS

1	DESCRIPTION.....	5
2	FEATURES.....	5
3	PRODUCT NAME AND MODEL NUMBER.....	5
4	FUNCTION OUTLINE.....	5
5	BLOCK DIAGRAM.....	6
6	DISPLAY CHARACTERISTICS.....	7
6.1	GENERAL SPECIFICATION.....	7
6.1.1	<i>Opto-Electric Specifications.....</i>	<i>7</i>
6.2	GAMMA CHARACTERISTICS.....	7
7	MECHANICAL PERFORMANCE.....	8
7.1	MECHANICAL SPECIFICATIONS.....	8
7.2	MECHANICAL TEST METHOD.....	9
8	ENVIRONMENTAL PERFORMANCE.....	10
8.1	OPERATION.....	10
8.2	STORAGE.....	10
9	INTERFACE SIGNAL SPECIFICATION.....	11
9.1	INTERFACE CONNECTION DIAGRAM.....	11
9.2	SIGNAL DEFINITION AND FUNCTION.....	11
9.2.1	<i>8 Bit Definition.....</i>	<i>11</i>
9.2.2	<i>10Bit Definition.....</i>	<i>12</i>
9.2.3	<i>12Bit Definition.....</i>	<i>12</i>
9.2.4	<i>13Bit Definition.....</i>	<i>13</i>
9.3	LVDS CONNECTOR PIN ASSIGNMENTS.....	13
9.4	ELECTRICAL CHARACTERISTICS.....	14
9.4.1	<i>Absolute Maximum Ratings.....</i>	<i>14</i>
9.4.2	<i>Electrical Characteristics.....</i>	<i>14</i>
9.5	VIDEO SIGNAL INTERFACE TIMING SPECIFICATIONS.....	15
9.6	I2C INTERFACE CONDITION.....	17
9.6.1	<i>Basic Specifications.....</i>	<i>17</i>
9.6.2	<i>I2C Ready Signal.....</i>	<i>17</i>
9.6.3	<i>Data Validity.....</i>	<i>17</i>
9.6.4	<i>Start & Stop Condition.....</i>	<i>17</i>
9.6.5	<i>Acknowledge.....</i>	<i>17</i>
9.6.6	<i>7-Bit Addressing for Device address.....</i>	<i>18</i>
9.6.7	<i>16-Bit Mode.....</i>	<i>18</i>
9.6.8	<i>Data Transfer Sequence (Write).....</i>	<i>18</i>
9.6.9	<i>Data Transfer Sequence (Read).....</i>	<i>19</i>
9.6.10	<i>Interface Circuit Diagram.....</i>	<i>19</i>
9.6.11	<i>I2C Bus Timing Specifications.....</i>	<i>20</i>
10	ADDRESS MAP.....	21
10.1	ADDRESS MAP.....	21
10.2	DETAILS OF SETTINGS.....	22

SamsungSDI Corporation Module	Specification	Plasma Display
11	INPUT POWER VOLTAGE SPECIFICATIONS	23
11.1	ELECTRICAL CHARACTERISTIC OVERVIEW FOR PDP MODULE VOLTAGES	23
11.2	ELECTRICAL CHARACTERISTIC OVERVIEW FOR IMAGE VOLTAGES	23
11.3	OUT DIMENSION FOR REFERENCE	23
11.4	POWER APPLYING SEQUENCE	24
11.5	PIN ASSIGNMENT OF CONNECTORS FOR POWER SUPPLY	28
11.6	MECHANICAL OUT DRAWING	29
12	ABEL	30
12.1	LABEL TYPE	30
12.1.1	Label for Product	30
12.1.2	Label for Operating Voltages	30
12.1.3	Caution/Warning Label	31
12.1.4	Label for PANEL Serial Number	31
12.2	LABEL LOCATION	31
13	PACKING	33
13.1	PACKING DIMENSION AND PARTS LIST	33
13.2	PACKING ASSEMBLY DRAWING	33
14	RELIABLITY	34
14.1	EXPECTED SERVICE LIFE	34
14.1.1	Definition	34
14.1.2	Test condition and life time	34
14.2	DISCLAIMER	34
15	WARNING / CAUTION / NOTICE	35
15.1	WARNING	35
15.2	CAUTION	36
15.3	NOTICE	37
16	ADDITIONAL SPECIFICATIONS	43
16.1	OPTO-ELECTRIC SPECIFICATIONS	43
16.2	ENVIRONMENTAL PERFORMANCE	43
16.3	CELL DEFECTS	43
16.3.1	Classification	43
16.3.2	Specifications	43
APPENDIX		45

1 DESCRIPTION

This model is a 50-inch wide full color plasma display module with a resolution of 1,366(H) × 768(V) pixels. The display module includes the Plasma Display Panel(PDP), the Panel driving electronics and the Logic Controller.

2 FEATURES

- Wide aspect ratio(16:9) 50inch diagonal display screen. The display area is 1106.48mm wide and 622.08mm high.
- Slim and light weight. The display module is 63.6mm in depth and weights only approx.24.5kg include power supply.
- 549755.81 million colors(13Bit), 68719.47 million colors(12Bit), 1073.7 million colors(10Bit), or 16.77 million colors(8Bit) combination of R,G and B digital data.
- High brightness, High contrast, Wide viewing angle. The screen has a white peak brightness of **typical 950cd/m²** , contrast of **typical 8,000:1** at 60Hz. And a viewing angle of greater than 160° comparable to those of CRTs.

3 PRODUCT NAME AND MODEL NUMBER

- Product name : 50-inch Full Color Plasma Display Module (Abbreviation : PDP module)
- Model number : **S50HW-YD04**

4 FUNCTION OUTLINE

- The plasma display Module has an APC(Automatic Power Control) function which restricts power consumption within the certain value with regard to each display load ratio.
- The plasma display Module is operated by following digital video signals; Vertical synchronous signal, Horizontal synchronous signal, DLCK and 8bits/10bits/12bits/13bits data signal of each R,G, and B color. All signals are based on LVDS level.
- The plasma display Module is operated at 50Hz or 60Hz frame rate. An external frame rate conversion is required in order to display the other formats.
- The PDP module requires several types of input voltage; voltage for LOGIC control board, Y-driver board, X-driver board and address buffer board.
- The plasma display Module is operated at progressive signal only. An external progressive scan conversion is required in order to display the other formats.
- The plasma display Module requires rated 100~240V, 50~60Hz of input power voltage. Maximum input voltage rating is AC 90~264V.



5 BLOCK DIAGRAM

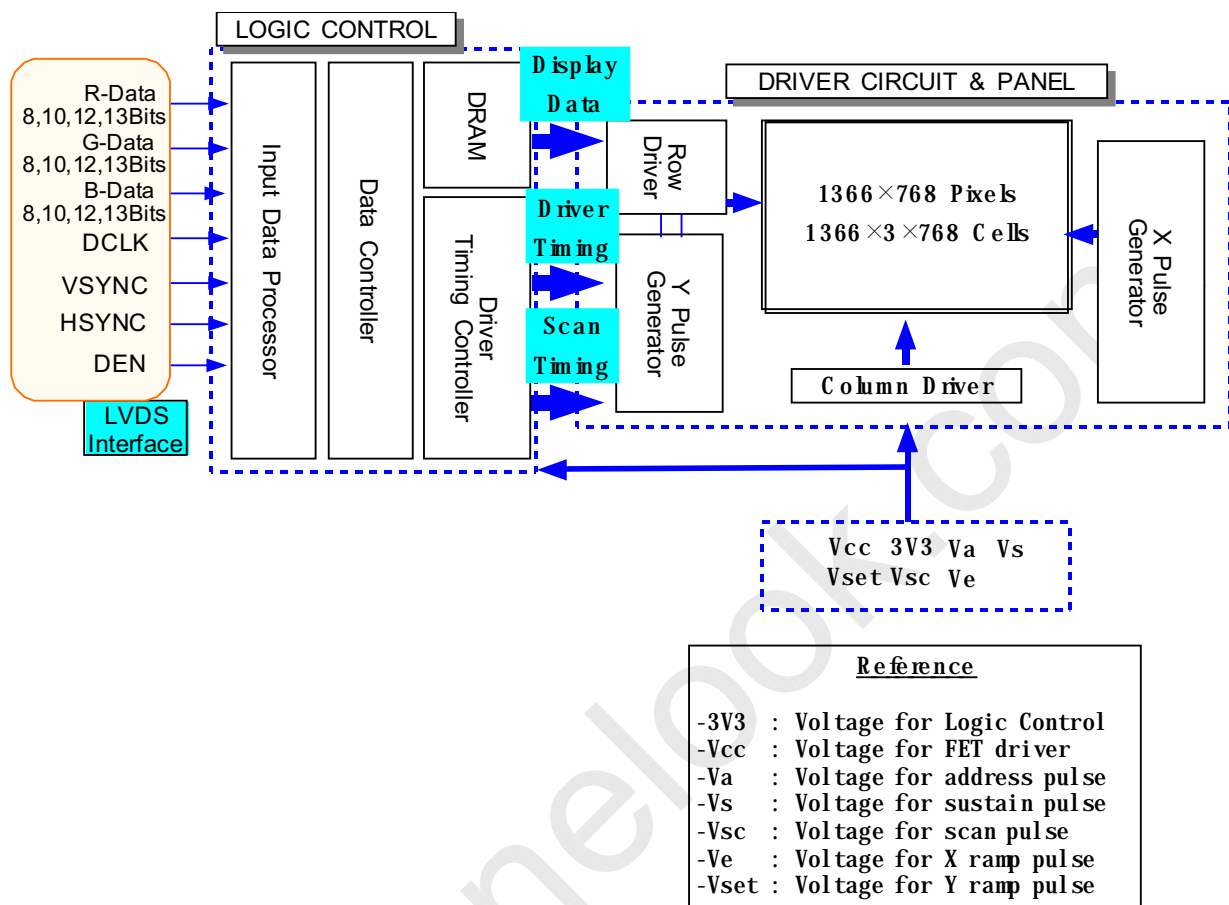

Figure-1. Block Diagram of PDP module

6 DISPLAY CHARACTERISTICS

6.1 General Specification

6.1.1 Opto-Electric Specifications

ITEM	Condition	60Hz	50Hz	Unit
Peak Brightness	1% white window	Min : 900 Typ : 950	Min : 900 Typ : 950	cd/m ²
Full White Brightness	Full white	Min : 120 Typ : 150	Min : 120 Typ : 150	cd/m ²
DRCR ¹	1% white window	Min :3000:1 Typ :8,000:1	Min :4000:1 Typ :5000:1	-
Power Consumption	Full white	Typ : 420 Max : 462	Typ : 420 Max : 462	W
Viewing Angle ²	Full white	160	160	Degree
Sound Pressure Noise Level	1m, F/White, 50~8kHz	32	32	dBA
Tvsync margin		±2	±2	Hz

6.2 Gamma characteristics

The PDP module is normally applied to the 2.2 gamma curve.

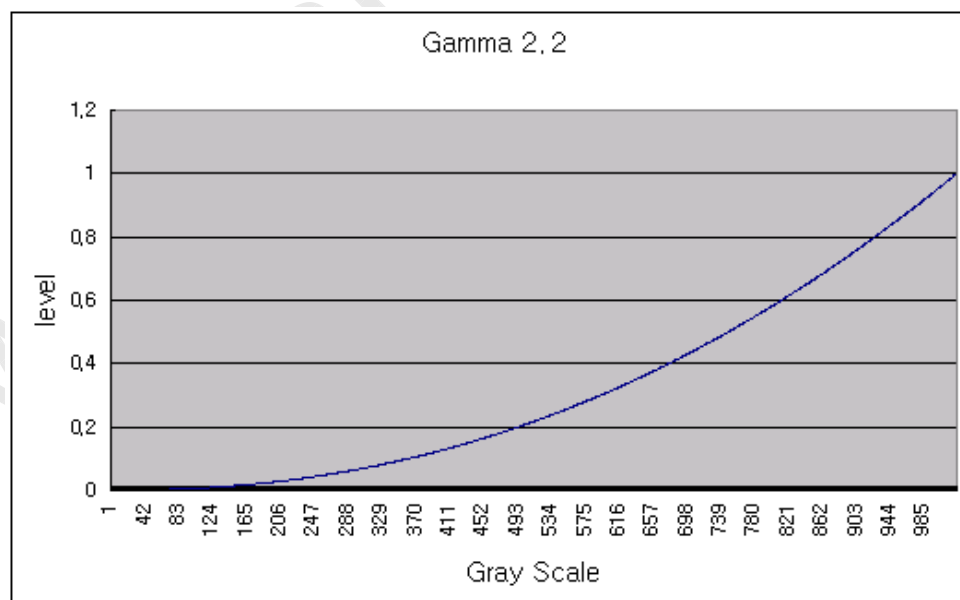

Figure 2 - Normalized Gamma Curve

¹ DRCR : Dark Room Contrast Ratio.

² It is the angle that meets 50% brightness level from center on full white pattern.

7 MECHANICAL PERFORMANCE

7.1 Mechanical Specifications

Item	Rating	
Outer Dimension	Width	1,184 ± 2mm
	Height	700 ± 2mm
	Thickness	63.8 +2 -0mm
Weight		Approximately 24.5kg

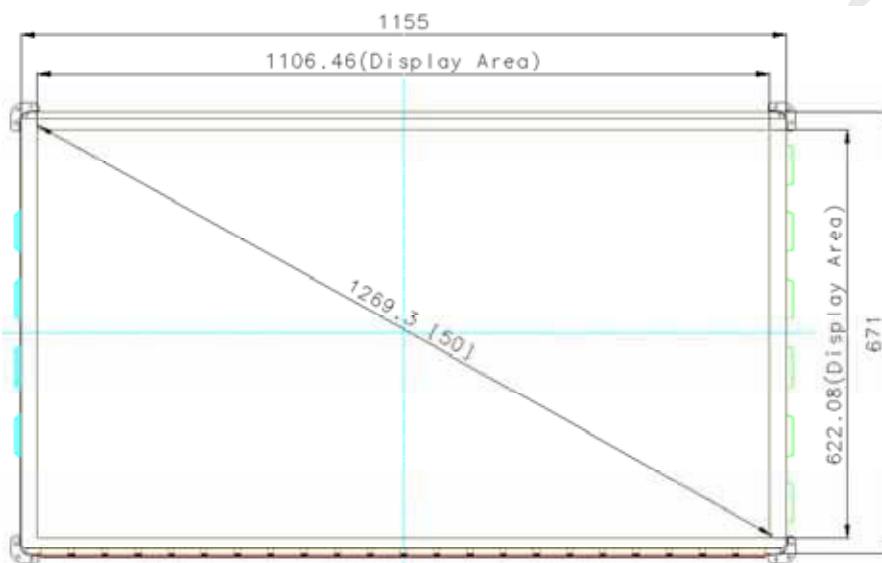

Figure 3 – Mechanical Dimension of Front Side

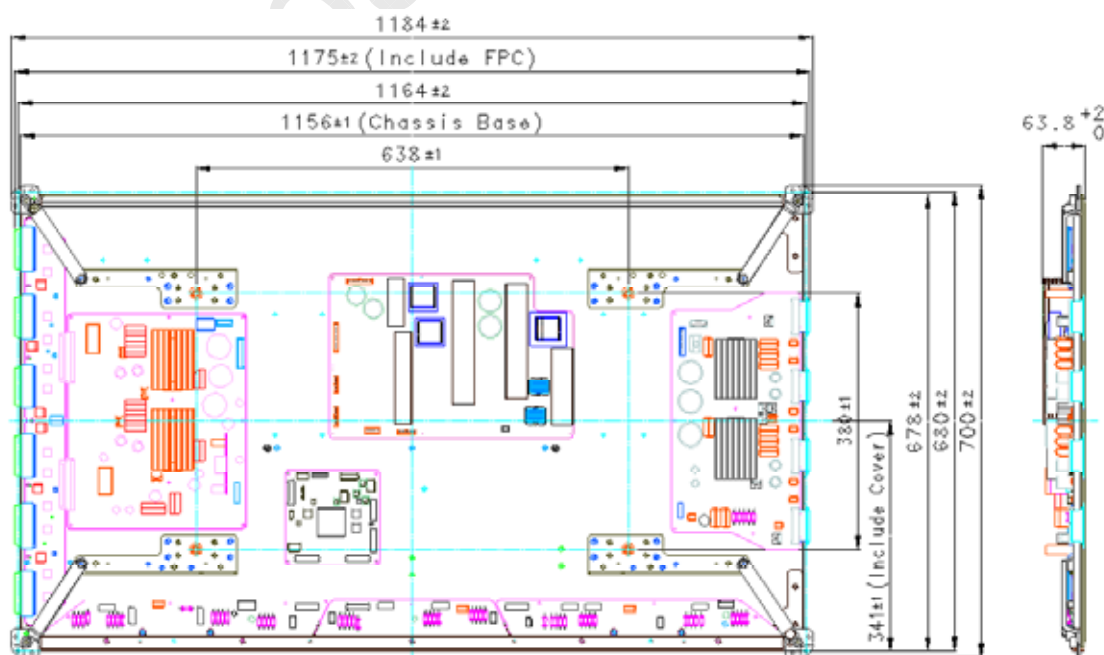

Figure 4 - Mechanical Dimension of Rear Side

7.2 Mechanical Test Method

Item	Rating		
Vibration ¹	Frequency		10 ~ 55 Hz
	Sweep Rate		1 Octave/min
	Stroke	X,Y direction	0.35 mm
		Z direction	0.175 mm
Shock ²	Acceleration	X,Y direction	less than 20G
		Z direction	less than 10G
	Duration Time		11 ms

The directions of X-, Y- and Z-axis are as shown in Figure5. The positive X direction is towards the left-side in the front view (to the right side in rear view); the positive Y and Z are up ward and front-to-rear direction respectively.

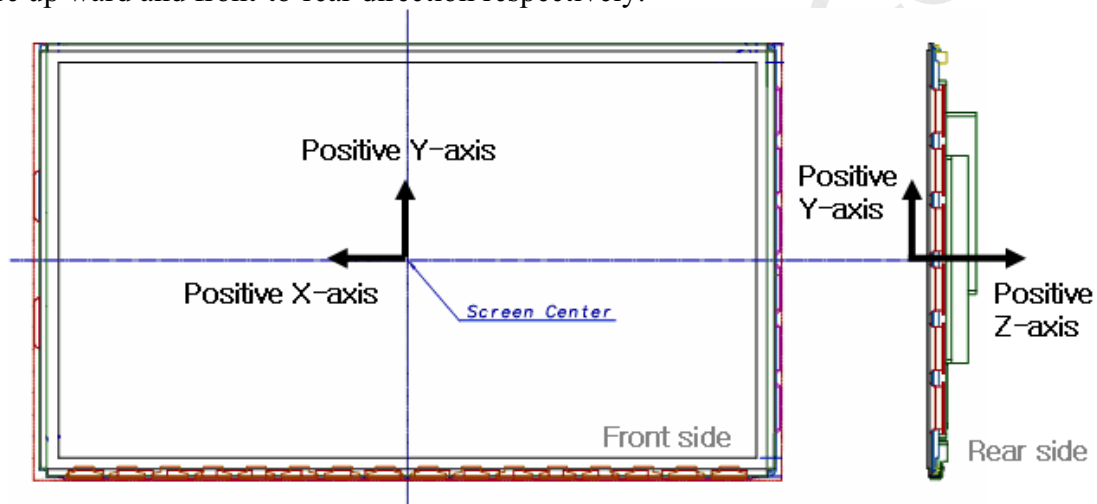

Figure5 – Test directions

¹ Vibration test shall be done for 30min every direction(x,y,z)

² Shock test shall be done 6 times every direction(x,y,z)



8 ENVIRONMENTAL PERFORMANCE

8.1 Operation

ITEM	Rating	
	Recommended	Absolute maximum
Temperature	5°C ~ 40°C	0°C ~ 60°C
Humidity ¹	20 ~ 70% RH	20 ~ 80% RH

8.2 Storage

ITEM	Rating
Temperature	-20°C ~ 70°C
Humidity	5 ~ 85% RH
Air Pressure	307 ~ 1013 hPa

¹ PDP Module shall not show condensation.

9 INTERFACE SIGNAL SPECIFICATION

PDP Module uses an LVDS interface for the signal input. It is defined as like below.
For details, refer to the data sheets published by the LVDS transmitter IC maker.

9.1 Interface Connection Diagram

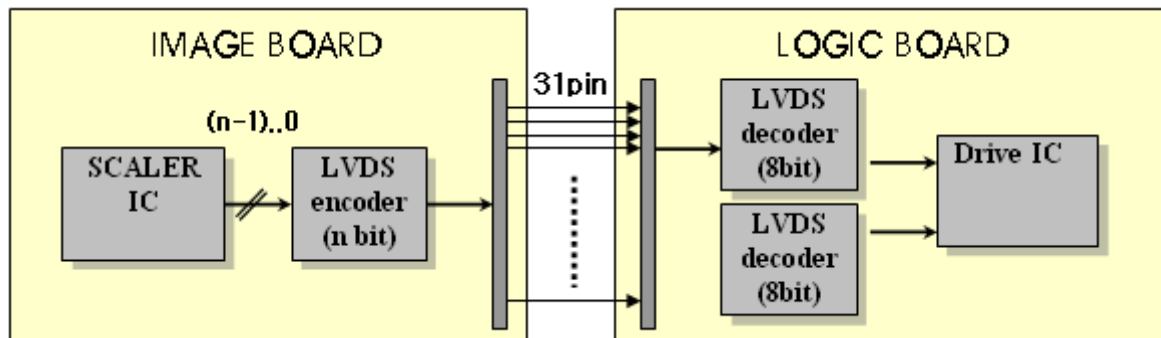

NOTE Do not connect or disconnect the LVDS connector when the system power is on. Otherwise, the LVDS interface IC could be damaged.

The length of connecting LVDS cable between image board and logic board is recommended not to be longer than 25.0cm.

9.2 Signal Definition and Function

A video signal (display data signal and control signal) is converted from parallel data to serial data with the LVDS transmitter and further converted into four sets of differential signals before input to this PDP module. These signals are transmitted seven times faster than dot clock signals. The dot clock signal is converted into one set of differential signals.

The LVDS signal definition and function are as follows in *Italic*:

9.2.1 8 Bit Definition

Symbol	I/O	Function	Remarks	
LVDS1	<i>RxIN0-</i>	I	Display Data Signal:	LVDS signal
	<i>RxIN0+</i>	I	R0, R1, R2, R3, R4, R5, G0	LVDS signal
	<i>RxIN1-</i>	I	Display Data Signal:	LVDS signal
	<i>RxIN1+</i>	I	G1, G2, G3, G4, G5, B0, B1	LVDS signal
	<i>RxIN2-</i>	I	Display Data Signal:	LVDS signal
	<i>RxIN2+</i>	I	B2, B3, B4, B5, Hsync, Vsync, DEN	LVDS signal
	<i>RxIN3-</i>	I	Display Data Signal:	LVDS signal
	<i>RxIN3+</i>	I	R6, R7, G6, G7, B6, B7	LVDS signal
	<i>RxCLKin-</i>	I	Dot Clock Signal:	LVDS signal
	<i>RxCLKin+</i>	I	CLK	LVDS signal
<i>SDA</i>	I/O	I2C serial data	3.3V CMOS	
<i>SCL</i>	I	Clock signal for SDA	3.3V CMOS	
<i>I2C_READY</i>	O	I2C enable signal	3.3V CMOS	

9.2.2 10Bit Definition

Symbol	I/O	Function	Remarks	
LVDS1	RxIN0-	I	Display Data Signal:	LVDS signal
	RxIN0+	I	R2, R3, R4, R5, R6, R7, G2	LVDS signal
	RxIN1-	I	Display Data Signal:	LVDS signal
	RxIN1+	I	G3, G4, G5, G6, G7, B2, B3	LVDS signal
	RxIN2-	I	Display Data Signal:	LVDS signal
	RxIN2+	I	B4, B5, B6, B7, Hsync, Vsync, DEN	LVDS signal
	RxIN3-	I	Display Data Signal:	LVDS signal
	RxIN3+	I	R8, R9, G8, G9, B8, B9	LVDS signal
	RxCLKin-	I	Dot Clock Signal:	LVDS signal
RxCLKin+	I	CLK	LVDS signal	
LVDS2	RxIN4-	I	Display Data Signal:	LVDS signal
	RxIN4+	I	R0, R1, G0, G1, B0, B1	LVDS signal
SDA	I/O	I2C serial data	3.3V CMOS	
SCL	I	Clock signal for SDA	3.3V CMOS	
I2C_READY	O	I2C enable signal	3.3V CMOS	

9.2.3 12Bit Definition

Symbol	I/O	Function	Remarks	
LVDS1	RxIN0-	I	Display Data Signal:	LVDS signal
	RxIN0+	I	R4, R5, R6, R7, R8, R9, G4	LVDS signal
	RxIN1-	I	Display Data Signal:	LVDS signal
	RxIN1+	I	G5, G6, G7, G8, G9, B4, B5	LVDS signal
	RxIN2-	I	Display Data Signal:	LVDS signal
	RxIN2+	I	B6, B7, B8, B9, Hsync, Vsync, DEN	LVDS signal
	RxIN3-	I	Display Data Signal and Control Signal:	LVDS signal
	RxIN3+	I	R10, R11, G10, G11, B10, B11	LVDS signal
	RxCLKin-	I	Dot Clock Signal:	LVDS signal
RxCLKin+	I	CLK	LVDS signal	
LVDS2	RxIN4-	I	Display Data Signal:	LVDS signal
	RxIN4+	I	R2, R3, G2, G3, B2, B3	LVDS signal
	RxIN5-	I	Display Data Signal:	LVDS signal
	RxIN5+	I	R0, R1, G0, G1, B0, B1	LVDS signal
SDA	I/O	I2C serial data	3.3V CMOS	
SCL	I	Clock signal for SDA	3.3V CMOS	
I2C_READY	O	I2C enable signal	3.3V CMOS	

9.2.4 13Bit Definition

Symbol	I/O	Function	Remarks	
LVDS1	RxIN0-	I	Display Data Signal:	LVDS signal
	RxIN0+	I	R5, R6, R7, R8, R9, R10, G5	LVDS signal
	RxIN1-	I	Display Data Signal:	LVDS signal
	RxIN1+	I	G6, G7, G8, G9, G10, B5, B6	LVDS signal
	RxIN2-	I	Display Data Signal:	LVDS signal
	RxIN2+	I	B7, B8, B9, B10, Hsync, Vsync, DEN	LVDS signal
	RxIN3-	I	Display Data Signal and Control Signal:	LVDS signal
	RxIN3+	I	R11, R12, G11, G12, B11, B12, R0	LVDS signal
	RxCLKin-	I	Dot Clock Signal:	LVDS signal
RxCLKin+	I	CLK	LVDS signal	
LVDS2	RxIN4-	I	Display Data Signal:	LVDS signal
	RxIN4+	I	R3, R4, G3, G4, B3, B4, G0	LVDS signal
	RxIN5-	I	Display Data Signal:	LVDS signal
	RxIN5+	I	R1, R2, G1, G2, B1, B2, B0	LVDS signal
SDA	I/O	I2C serial data	3.3V CMOS	
SCL	I	Clock signal for SDA	3.3V CMOS	
I2C_READY	O	I2C enable signal	3.3V CMOS	

9.3 LVDS Connector Pin Assignments

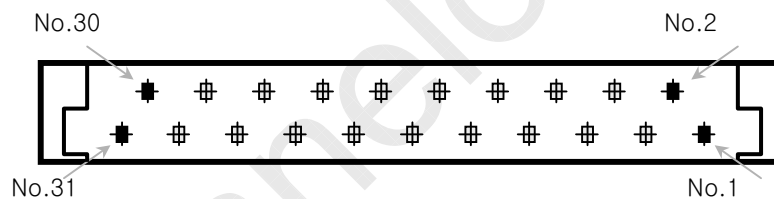

PIN No	PIN NAME	PIN No	PIN NAME	PIN No	PIN NAME
1	GND	11	Rx2-	21	GND
2	GND	12	Rx2+	22	I2C_READY
3	Rx0-	13	GND	23	Rx4-
4	Rx0+	14	GND	24	Rx4+
5	GND	15	RxCLK-	25	N.C.
6	GND	16	RxCLK+	26	GND
7	Rx1-	17	N.C.	27	SCL
8	Rx1+	18	N.C.	28	GND
9	Rx5-	19	Rx3-	29	SDA
10	Rx5+	20	Rx3+	30	GND
				31	N.C.

NOTES:

- CN2006 connector is located in Logic Board.
- Pin to Pin pitch of connector CN2006 is 0.625 mm.
- Pin numbering order : right to left view from component side of Logic Board.

9.4 Electrical Characteristics

9.4.1 Absolute Maximum Ratings

Common conditions : Ta = 25°C, Vcc = 3.3V

Parameter		Condition	Symbol	Ratings	Unit
LVDS	RxIN0-/+, RxIN1-/+, RxIN2-/+, RxIN3-/+, RxIN4-/+, RxIN5-/+, RxCLKin-/+	Input Voltage	Vi	-0.3~3.6	V
		Input Current	Ii	-10~10	μA
3.3V CMOS	SCL, SDA	Input Voltage	Vi	-0.3~3.6	V
	I2C_READY	Output Voltage	Vo	-0.3~3.6	V

9.4.2 Electrical Characteristics

Common conditions : Ta = 25°C, Vcc = 3.3V

Parameter		Symbol	Conditions	Min.	Typ.	Max.	Unit
LVDS	High Level Input Voltage	Vth	VCM=1.2V	-	-	100	mV
	Low Level Input Voltage	Vtl	VCM=1.2V	-100	-	-	mV
	Input current	Iin	VIN= +3.6V/GND	-	-	±10.0	μA
I2C	Input Voltage	Vih		0.5×Vcc	-	4.1	V
		Vil		-0.5	-	0.3×Vcc	V
	Input Capacitance	Vin	-	-	-	8	pF
	Output Voltage	Voh	Ioh = 8 mA	2.4	-	-	V
		Vol	-	-	-	0.4	V
	Output Current	Iol	-	-	-	10	mA

9.5 Video Signal Interface Timing Specifications

The table below indicates the conditions of input video signal before LVDS conversion.

Parameter	Symbol		Min.	Typ.	Max.	Unit
DCLK	Period	Tclk	14.08	-	12.82	ns
	Frequency		71.2	74	78	MHz
Hsync	Period	Thp	1451	-	-	Tclk
	Frequency	Fh	-	-	-	KHz
	Width	Twh	6	-	-	Tclk
Vsync	Period	Tvp	810	-	-	Thp
	Frequency	Fv	-	-	-	Hz
	Width	Twv	2	-	-	Thp
Data Enable	Horizontal Valid	Thv	1366	-	-	Tclk
	Horizontal Back Porch	Thbp	56	-	-	Tclk
	Vertical Valid	Tvv	768	-	-	Thp
	Vertical Back porch	Tvbp	8	-	-	Thp

NOTE A Example of DCLK Frequency

$$Tclk_max = (1366*74)/(1366+(750- \mathbf{THC})*74*0.001)$$

if **THC** = 800ns, Tclk_max = 74.2MHz

SamsungSDI Corporation
Module

Specification

Plasma Display

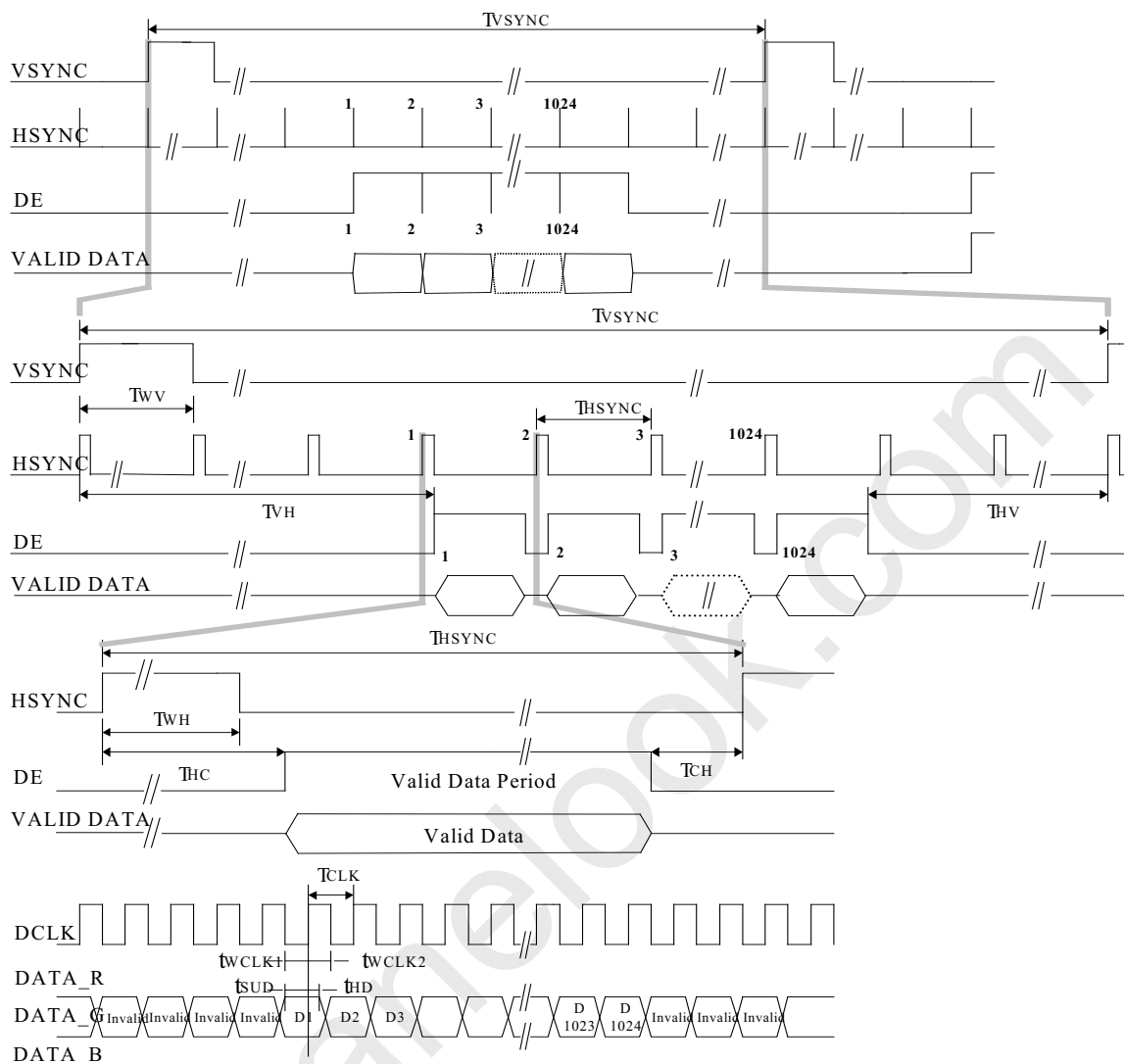

Figure 6 - Interface Timing Sequence

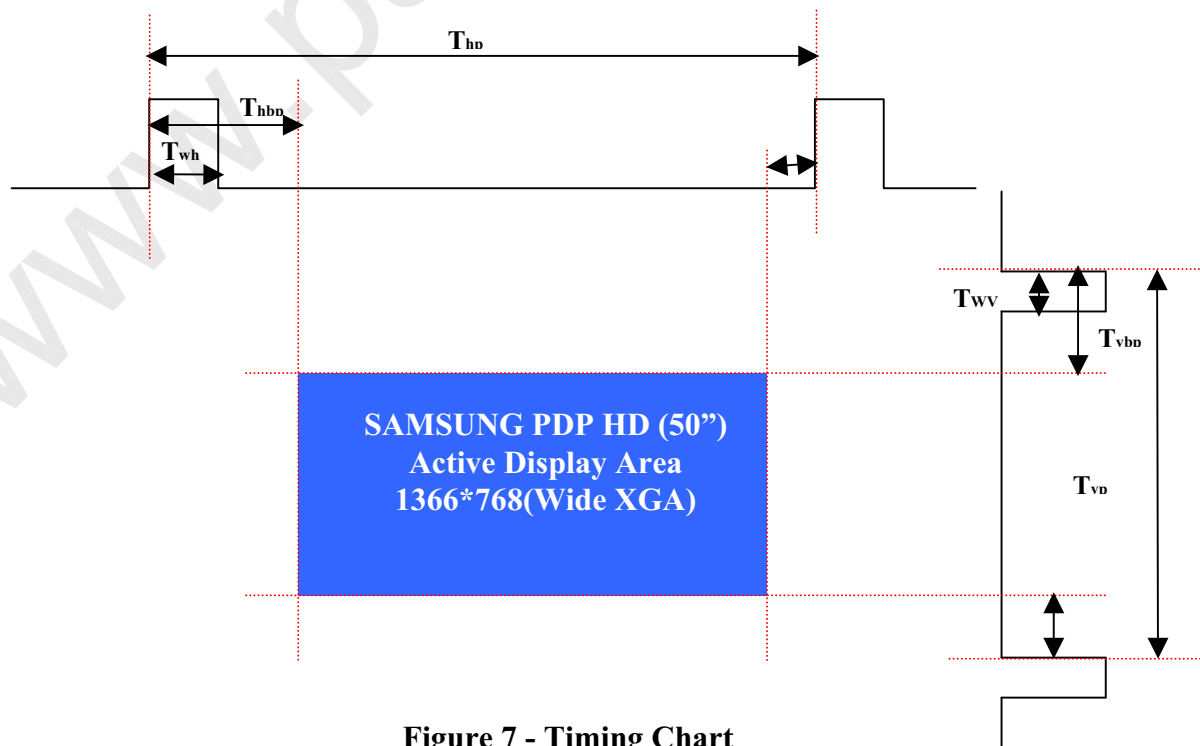

Figure 7 - Timing Chart

9.6 I2C Interface Condition

9.6.1 Basic Specifications

This PDP module has the I2C bus serial data communication function. The customer may use this function to make settings for PDP module characteristics of several items.

Parameter	Specifications
Recommended Transfer Rate	100 kbps
Device Status	Slave Receiver
Slave Address	Write: 66(Hex), Read: 66(Hex)

9.6.2 I2C Ready Signal

I2C control is available only when I2C-Ready signal is 'High' state.

9.6.3 Data Validity

Amount of data that is transferred is 1-Bit per 1 SCL cycle. Data is valid when SCL is high and recognized as to state of SDA.

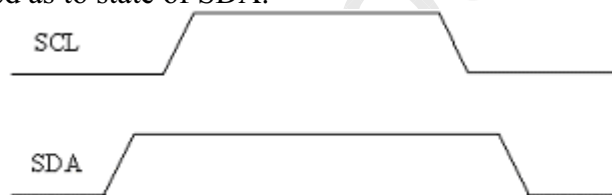

9.6.4 Start & Stop Condition

Start /Stop condition is generated by Master (=Image B'D). Before start condition or after stop condition, any SDA isn't recognized valid data.

- Start condition : SCL high & SDA transition from H to L
- Stop condition : SCL high & SDA transition from L to H

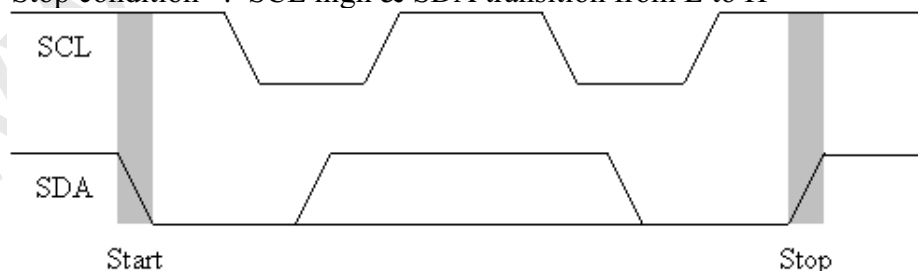

9.6.5 Acknowledge

In case of stopping read data, the master(= Image B'D) should give NO ACK signal to slave by SDA. Slave (=PDP module) gives ACK whenever 8-bit transfer is done.

**SamsungSDI Corporation
Module**

Specification

Plasma Display

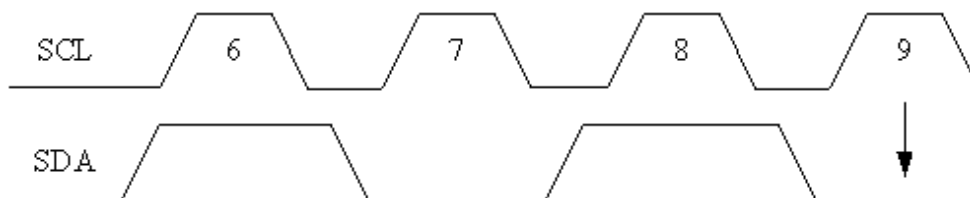

9.6.6 7-Bit Addressing for Device address

Master could choose slave by 7-bit slave address and decide what procedure is by R/W bit (H=Read procedure, L=Write procedure).

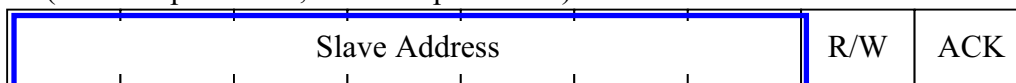

9.6.7 16-Bit Mode

The basic I2C format (8-bit (Byte)) is expanded by 16-bit (Word). Therefore this PDP module's I2C architecture consists of 7-bit slave addressing, 16-bit base addressing and 16-bit data (Refer to 'Write & Read Operation').

9.6.8 Data Transfer Sequence (Write)

The basic I2C format (8-bit (Byte)) is expanded by 16-bit (Word). Therefore this PDP module's I2C architecture consists of 7-bit slave addressing, 16-bit base addressing and 16-bit data (Refer to 'Write & Read Operation').

Note 1: Black letters mean master (=Image B'D) 's bus occupation.

Note 2: Blue letters mean slave (=PDP module)'s bus occupation.

Note 3: Option Bit = 10: RAM

The ROM mode is very slow, it is impossible to use normal I2C communication. **The image board can only use RAM mode.**

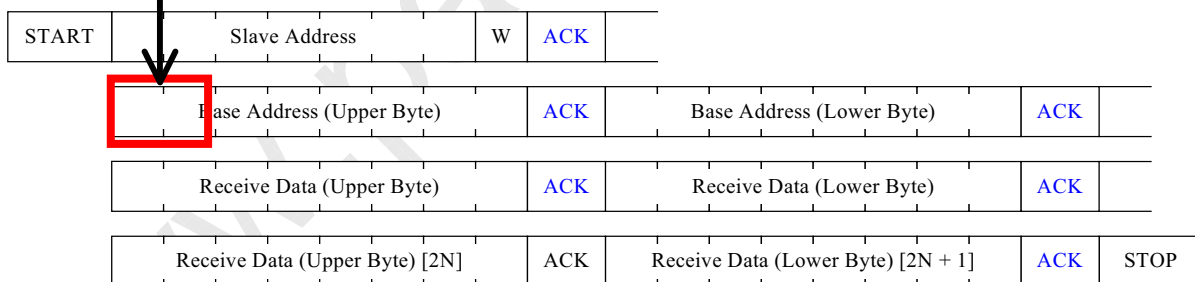

9.6.9 Data Transfer Sequence (Read)

The basic I2C format (8-bit (Byte)) is expanded by 16-bit (Word). Therefore this PDP module's I2C architecture consists of 7-bit slave addressing, 16-bit base addressing and 16-bit data (Refer to 'Write & Read Operation').

Note 1: In advance, master should initialize write sequence by giving base address and stop condition.

Note 2: After start condition and slave addressing, master could receive data from slave.

Note 3: Master should give acknowledge whenever 8-bit data is received.

Note 4: 'No acknowledge' could make master give stop condition on bus. Therefore, NACK is used for master to stop receiving data from slave.

Note 5: Black letters mean master (=Image B'D)'s bus occupation.

Note 6: Blue letters mean slave (=PDP module)'s bus occupation.

Note 7: Option Bit = 10: RAM

The ROM mode is very slow, it is impossible to use normal I2C communication. **The image board can only use RAM mode.**

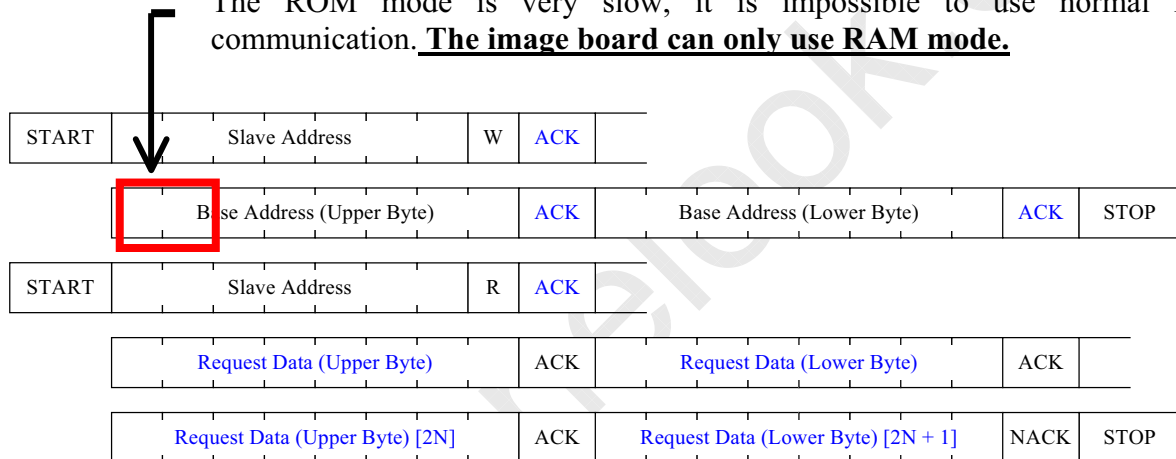

9.6.10 Interface Circuit Diagram

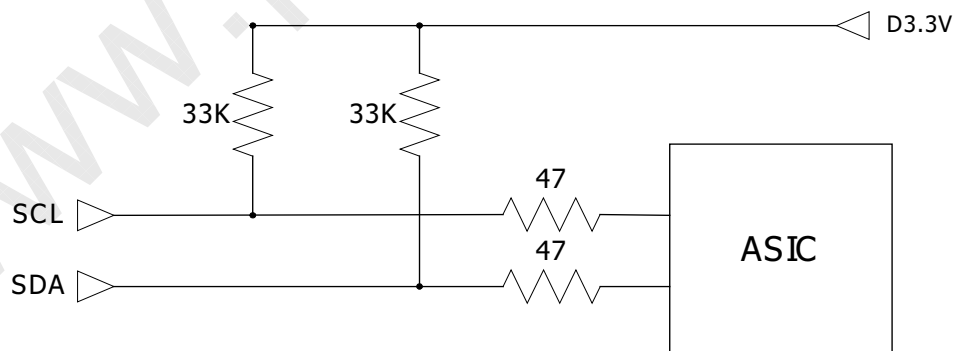

9.6.11 I2C Bus Timing Specifications

Parameter	Symbol	Standard			
		Min.	Typ.	Max.	Unit
SCL Input Frequency	fSCL	-	100	200	kHz
SCL Input "HIGH" Period	tHIGH	4.0	-	-	μ s
SCL Input "Low" Period	tLOW	4.7	-	-	μ s
Start Condition Set Up Time	tSU.STA	4.7	-	-	μ s
Start Condition Hold Time	tHD.STA	4.0	-	-	μ s
Data Input Set Up Time	tSU.DAT	0.25	-	-	μ s
Data Input Hold Time	tHD.DAT	5	-	-	μ s
Stop Condition Set Up Time	tSU.STO	4.0	-	-	μ s
Data Output Delay Time	tPD	0.1	-	-	μ s
Data Output Hold Time	tDH	0.1	-	-	μ s
SDA Bus Free Time	tBUF	4.7	-	-	μ s
SCL, SDA Input Rising Time	tR	-	-	1.0	μ s
SCL, SDA Input Falling Time	tF	-	-	0.3	μ s
SCL, SDA Line Capacitor	Cb	-	50	100	pF

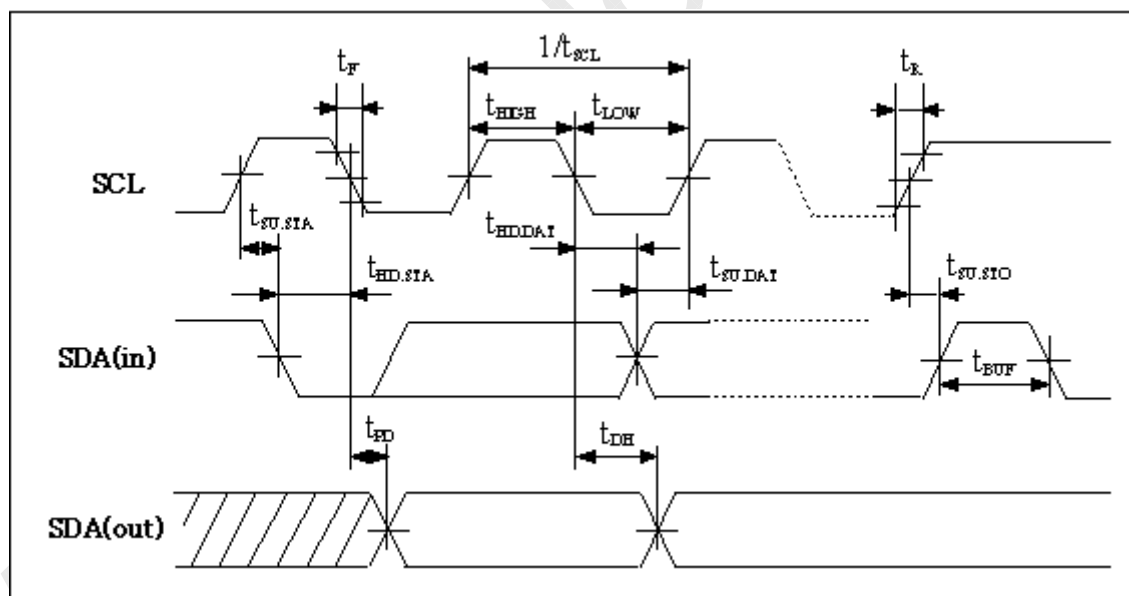

Figure 8 - I2C Bus Timing Diagram

10 ADDRESS MAP**10.1 Address Map**

The I2C address map has three areas as below. , i.e. NTSC / PAL common system area, NTSC-only system area and PAL-only system area.

The sub-address table for NTSC is shown below. The sub-address region for NTSC is 0000~1FFF, and for PAL 2000~3FFF

Basically address map for PAL is the same as that of NTSC except the offset address. For example, 8080h for NTSC is correspondent to A080h for PAL.

*I2C Slave Address Write: 66 (hex), Read: 66 (hex)

Sub Address	Data															Note	
	D15	D14	D13	D12	D11	D10	D9	D8	D7	D6	D5	D4	D3	D2	D1		D0
0080			PS														R/W
0081					DL												R/W

[NOTE]

- Only sub-addresses shown in above table are allowable for access. An access to the any other address than shown in above sub-address table may lead to an abnormal system down or permanent damage.
- 0000~007F : Area for NTSC/PAL common system registers .
0080~1FFF : Area for NTSC-only system.
2080~3FFF : Area for PAL-only system.
- I2C Address bit width in Address map : 14 bit[13:0]
* MSB 2bit[15:14] : Optional bit (refer to Note7 in 33page)

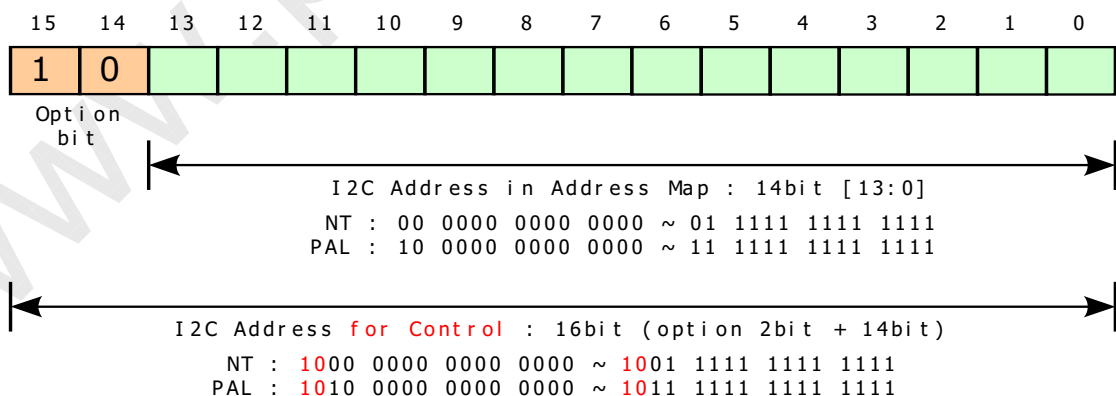
I2C Address

10.2 Details of Settings

Sub Address	Data Bit	Symbol	Item / Function	Setting [hex]		
				Range	Initial	
					60Hz	-
0080(NT) 2080(PAL))	8~13	PS	Pattern Select Patterns below are valid when IE (Internal clk or External clk) is set to '1'. 00: Full Window (Black) 01~04: Full Window (White,Red,Green,Blue) 05 : 1 point Box(White, Windows size) 06~09: 9 Point Box (White,Red,Green,Blue) 0A : 1% Window , 0B: Color Bar 0C~0D: Gray Bar (Horizontal, Vertical) 0E: Half Gray, 0F:Cross Hatch, 10:Dot Array, 11:3% widow 12~13: 16step Gray Bar (Vertical, Horizontal) 14~15: Vertical Ramp Pattern (Stay, Scroll) 16~17: Horizontal Ramp Pattern (Stay, Scroll) 18 : Horizontal Ramp WRGB Pattern	00~17	01	-
0081	8~15	DL	Data Level Patterns below are valid when IE (Internal clk or External clk) is set to '1'. 00~FFF : 0~ 256 Gray Level.	000 ~FFF	FFF	-

NOTE 1. Sub Address for pattern select shall be accessed for test use only.
For ordinary operating conditions, values of these address should be set to initial values.

11 INPUT POWER VOLTAGE SPECIFICATIONS

11.1 Electrical Characteristic Overview for PDP Module Voltages

Output Name	Nominal Voltage(V)	Output Current			(*1)Load Regulation (%)	(*2)Variable Range(V)	Remark
		Min.	Nor.	Max			
Vs	+198V	0.1A	1.3A	1.6A	±1.5	190V~210V	Sustain voltage
Va	+60V	0.1A	1.6A	2.0A	±1.5	50V~72V	Address voltage
Vscan	-190V	0.01A	0.08A	0.15A	±1.5	-220V~-180V	Scan voltage
Vset	+190V	0.01A	0.05A	0.07A	±1.5	180V~220V	Reset voltage
Ve	+120V	0.01A	0.05A	0.07A	±1.5	90V~130V	Bias voltage
Vg	+15V	0.1A	0.5A	1.5A	±5	Fixed	Drive gate in FET
D5V	+5.2V	0.1	-	2.5	±5	Fixed	Logic in X,Y driving
D3V3	+3.4V	0.1	2.0A	4.0A	±5	Fixed	Drive IC in Logic

*1. This means nominal voltage stability when current is changed from min to max.

*2. The output voltages for Vs, Va, Vscan, Vset, Ve could be varied within variable range by feedback variable resistors.

■ Above voltage levels are normal value. They are adjustable to drive Panel.

11.2 Electrical Characteristic Overview for Image voltages

Output Name	Nominal Voltage(V)	Output Current			Load Regulation (%)	Variable Range(V)	Remark
		Min.	Nor.	Max			
D5V	+5.2V	0.1A	1.0A	2.0A	±5	Fixed	Image Board
D3V3	+3.4V	0.1A	2.0A	4.0A	±5	Fixed	Image Board
A12V	+12V	0.1A	1.6A	2.0A	±5	Fixed	Image Board
Vamp (*3)	+12V	0.1A	3.1A	4.0A	±5	Selectable 12V or 24V	Image Board
	+24V	0.1A	1.4A	2.0A			
33Vt	+33V	-	0.01A	0.01A	±10	Fixed	Image Board
5VSB	+5.2V	0.1A	1.0A	2.0A	±5	Fixed	Image Board

*3. Vamp: Default 12V setting, Do not change 12/24V Jumper setting.

Notice: Confirm 12V/24V Jumper position before use.

11.3 Out Dimension for reference

Length(mm)	Width(mm)	Height(mm)	Remark
360mm	245mm	Max. 42mm	From PCB top

11.4 Power Applying Sequence

▶ AC_on Sequence

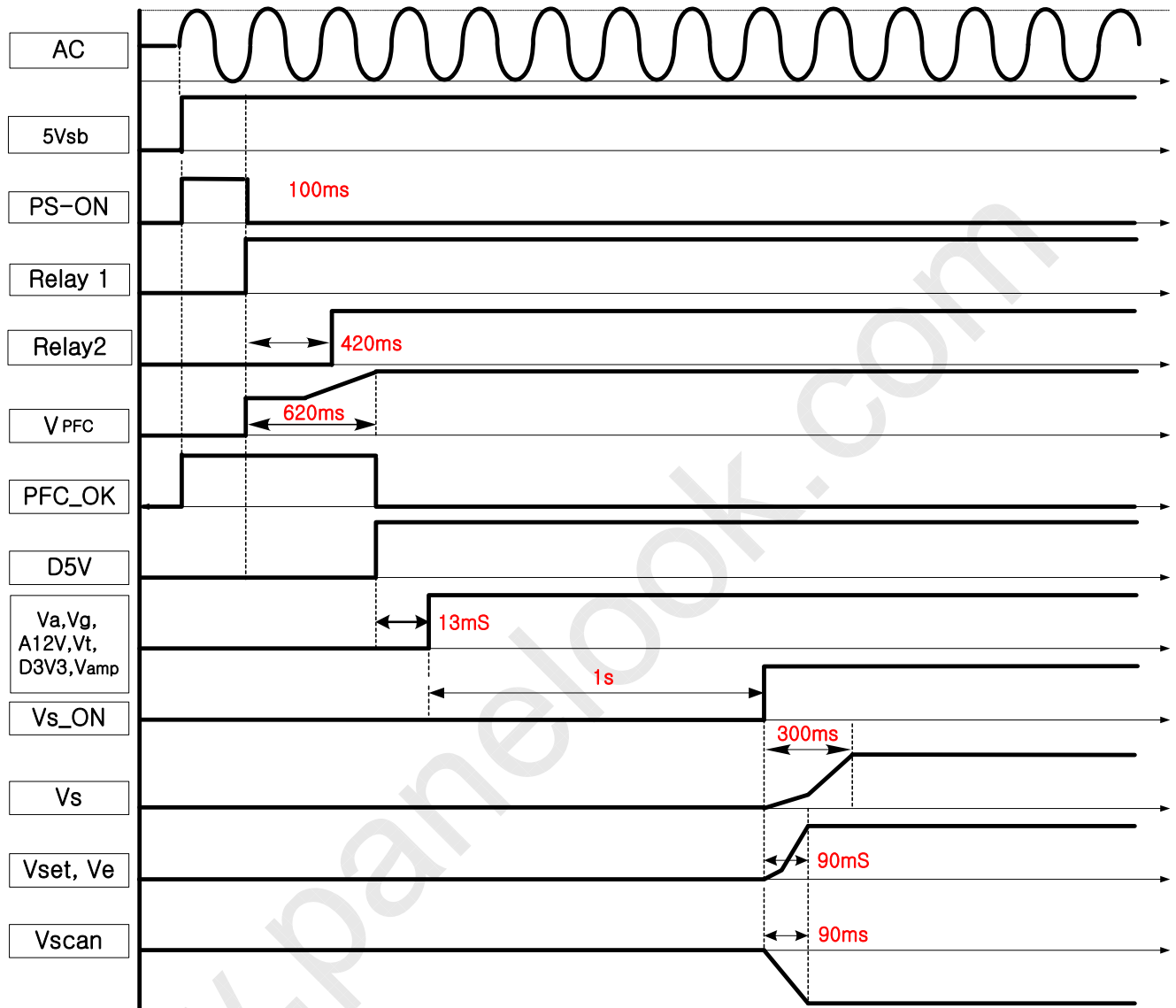

*1. Reference value.

*2. Vs_on signal is output from Logic board to PSU.

*3. Vs should be enable with Vs_on signal(Active High) from Logic.

*4. Vs should be always higher than Ve while D3V3 is alive.

*5. I2C Ready signal is output from Logic board to Image board.



▶ AC_off Sequence

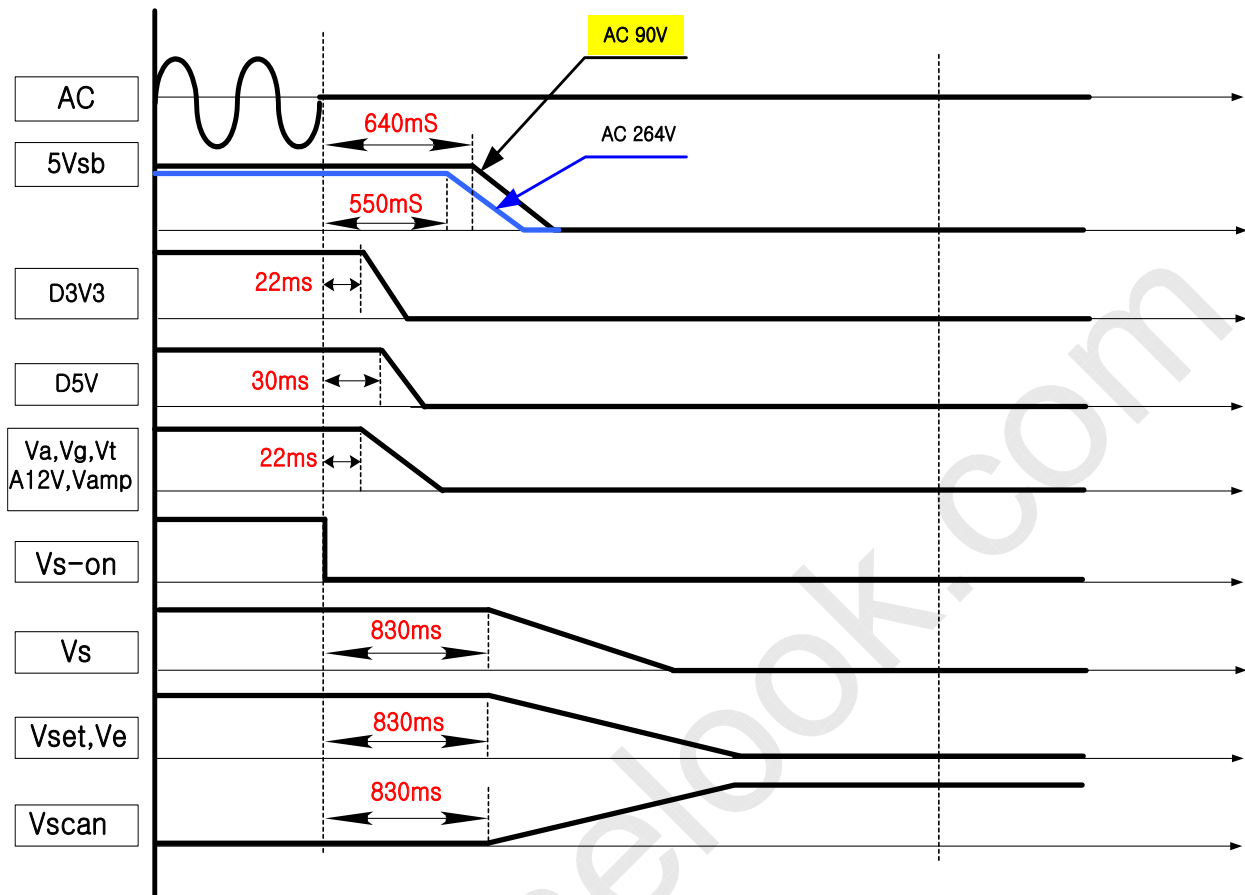

*1. D3V3 discharge should be faster than other voltages.

D3V3 should discharge before Vg voltage level is 11V and Vs voltage level is lower than Ve.

- Either spontaneous discharge or active discharge is available for PFC, Vs, Va, Vset, Vscan, Ve as long as D3V3 has discharged before other voltages.

► Relay_on Sequence

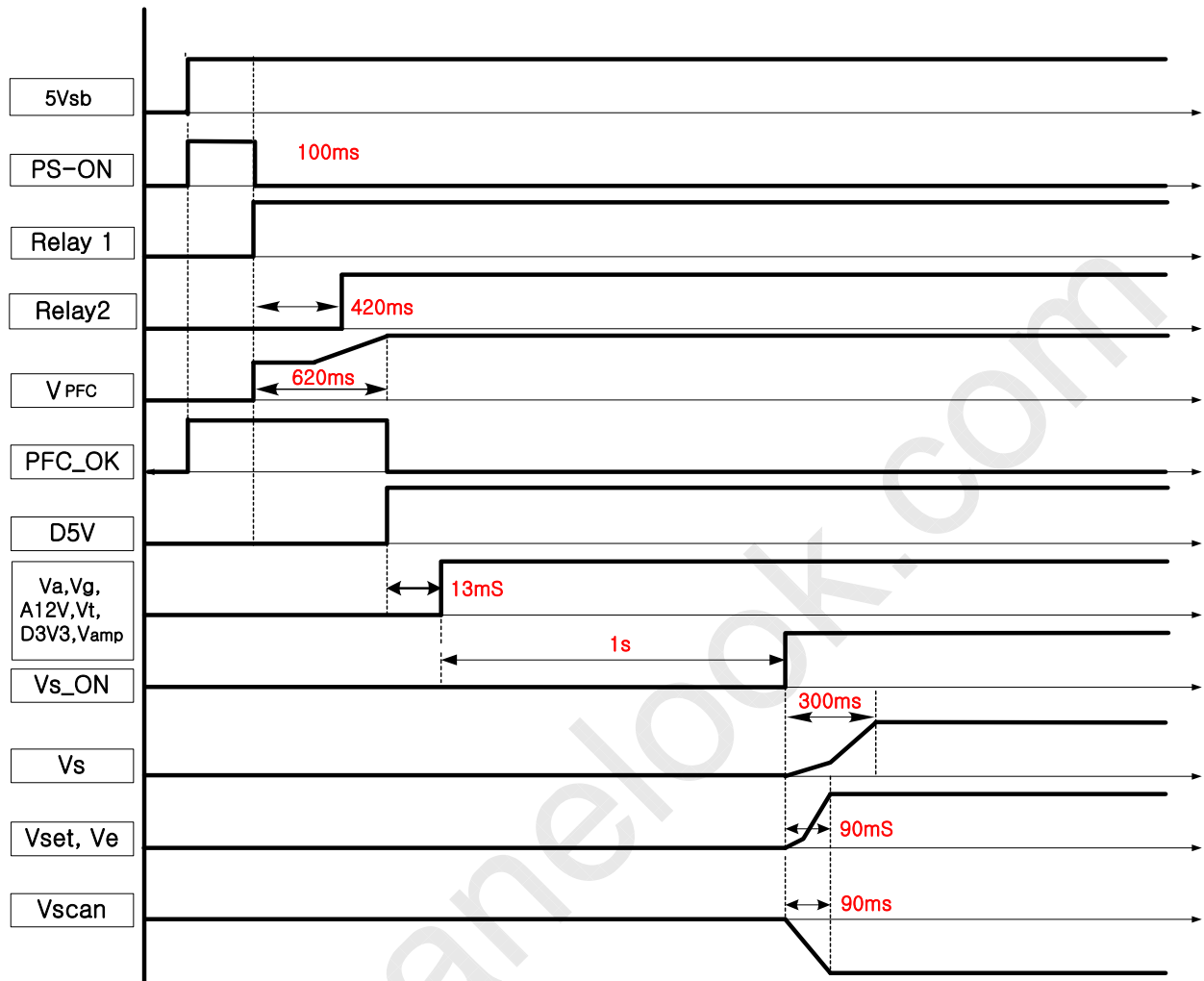

► Relay_off Sequence

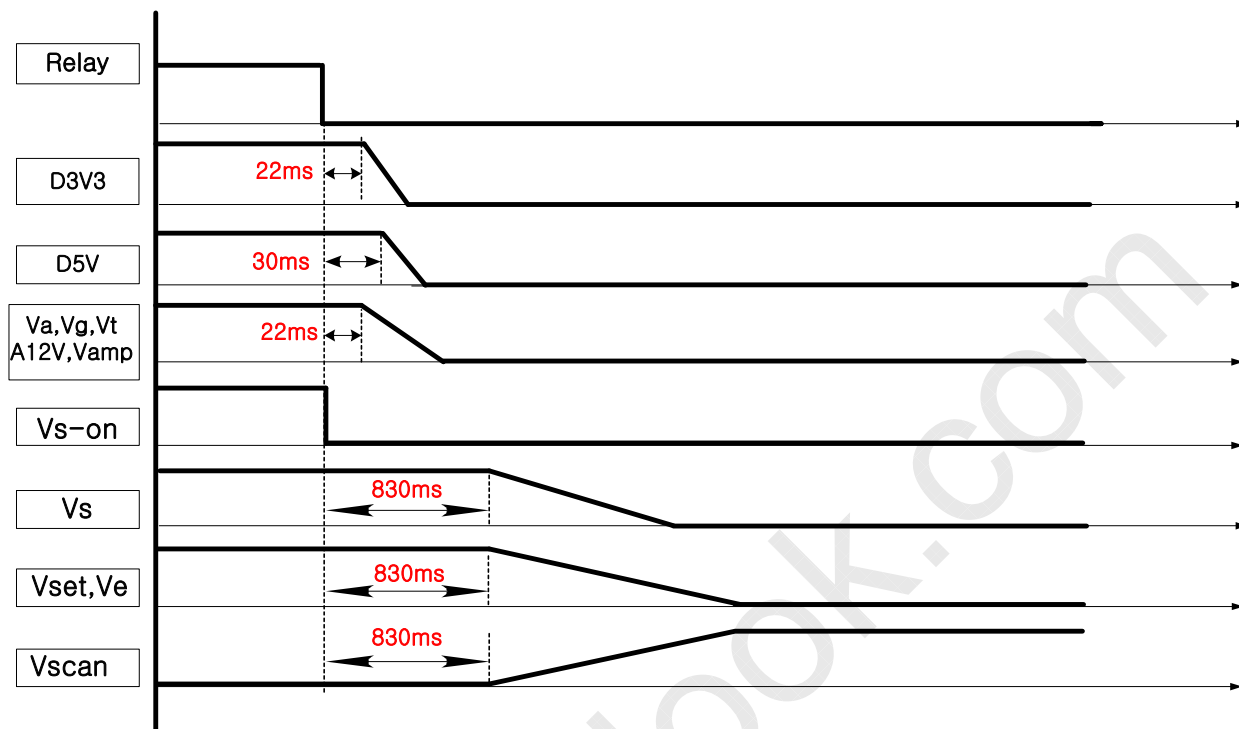

11.5 Pin assignment of connectors for Power Supply

Location No.	CN8001	CN8007	CN8006	CN8004	CN8005	CN8003	CN8002
Function	AC Input	X-Main	Y-Main	Image	Buffer	Image	Logic
No. of Pin	3 pins	8 pins	9 pins	10 pins	5 pins	11 pins	10 pins
Con. Type	JST B2P3-VH	Molex 35313-0960	Molex 35313-1060	Molex 35312-1060	Molex 35313-0560	Molex 35312-1160	Molex 35312-1060
Pin No.	Pin Name	Pin Name	Pin Name	Pin Name	Pin Name	Pin Name	Pin Name
1	Netural	D5V	D5V	D5V	Va	D5V	D3V3
2	N.C	Vg	Vg	GND	N.C	GND	D3V3
3	Live	GND	GND	A12V	D5V	D3V3	GND
4		GND	Vscan	GND	N.C	D3V3	GND
5		Ve	GND	Vamp	GND	GND	D5V
6		GND	Vset	Vamp		GND	GND
7		GND	GND	GND		A12V	Relay
8		Vs	GND	GND		(*1)PS-ON	AC_DET
9		Vs	Vs	Vt		GND	Vs_on
10			Vs	GND		Vsb	D5V
11						(*2)THEM_DET	

*1. This is a signal(Active low) from image board to Logic main. (High : 3.3V, Low : 0V)

***2. Stand By Power Consumption**

Max. 0.65W (condition : Module M3, Input Voltage 240Vac/60Hz)

*3. This is a signal from PSU to image board (Overheat : 5V, normal : 0V)

It stop the PSU when THEM_DET is high.



11.6 Mechanical Out Drawing

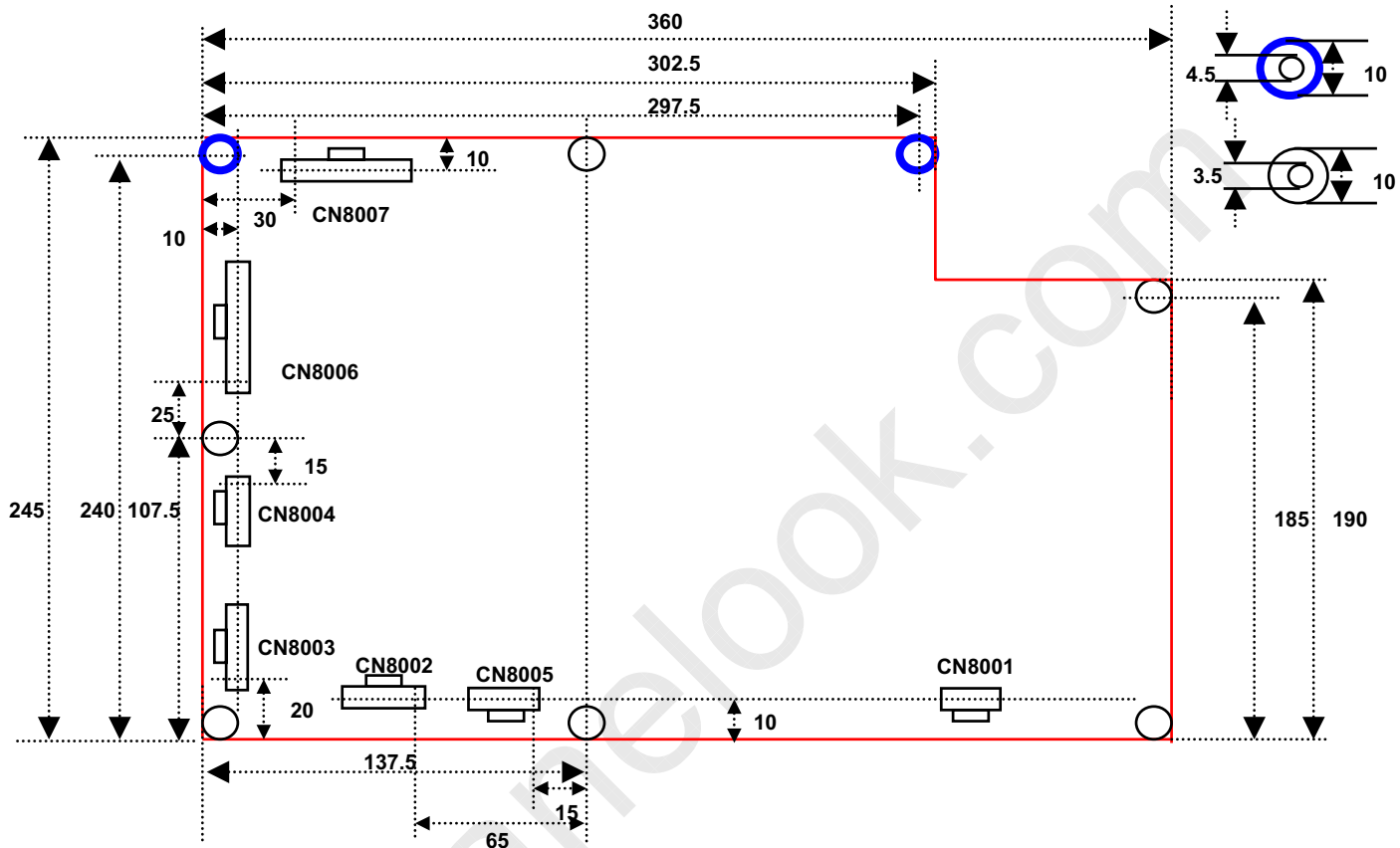





12 ABEL

12.1 Label Type

12.1.1 Label for Product

	PDP MODULE (S50HW-YD04)		
Model : S50HW-YB01		E233314 / E211281	
Rated Input : 190-210V,2.4A/55-75V,3.5A/-190 - -210V,0.1A/ (---) 5.2V,3.5A/3.5V,5.0A (option)		Serial No.	bar code
Manufactured : xxxx.xx.xx		Made in Korea	

■ Bar Code for MODULE Serial Number

 C001D6B01A0001

C	001	D	6	B	01	A	0001
Production Area	Model	Assembl y Line	Ass'y Year	Ass'y Month	Ass'y Date	Working Shift	Ass'y Num ber
C: CHEONA N		D Line	2006	A:Oct B:Nov C:Dec	1 st	A: Day B : Afternoon C : Night	0001~9999

12.1.2 Label for Operating Voltages

<input type="checkbox"/> NTSC		<input type="checkbox"/> NTSC/PAL			
Va	Vsc	Vs	Ve	Vset	
5V2	5V_SW	12V	8.6V	VSND+	VSND-
12 Nc					

12.1.3 Caution/Warning Label



12.1.4 Label for PANEL Serial Number

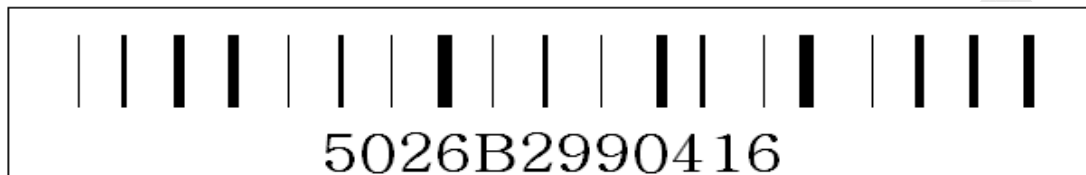

55	2	6	B	29	90416
Model Type	Production Line	Production Year	Production Month	Production Date	Production Number
2digit	2 nd Line	2006	A : Oct B : Nov C : Dec	29 th	00000~99999

NOTE Serial Number above is defined that it's 42HD W1 PANEL made in 29th.Nov.2006 on 2nd production line.

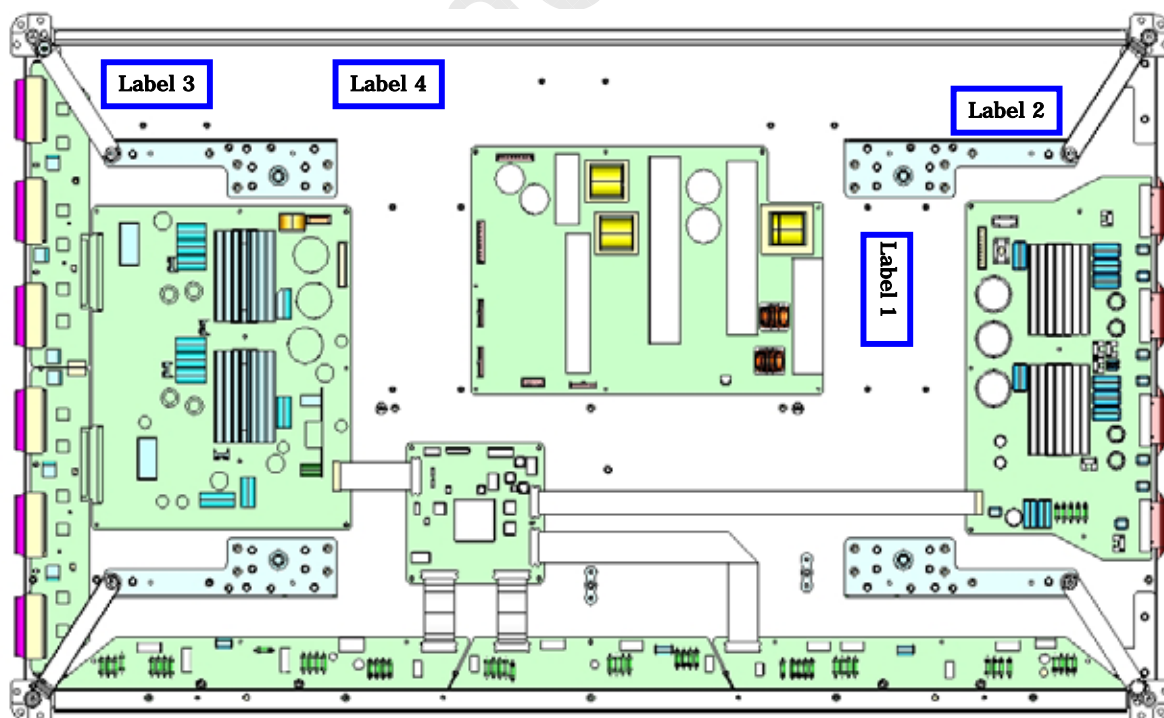

12.2 Label location

NOTE Label 1 for Product Label
Label 2 for Operating voltages Label



**SamsungSDI Corporation
Module**

Specification

Plasma Display

Label 3 for Caution/Warning Label
Label 4 for PANEL Serial Number Label

www.panelook.com

13 PACKING

13.1 Packing Dimension and Parts List

- Number of Module in 1 package: 10 Modules
- Packing dimensions (W*L*H): 1350*895* 960 (mm) (Including Pallet)
- Weight: About 280 ± 5 (Kg)

13.2 Packing Assembly Drawing

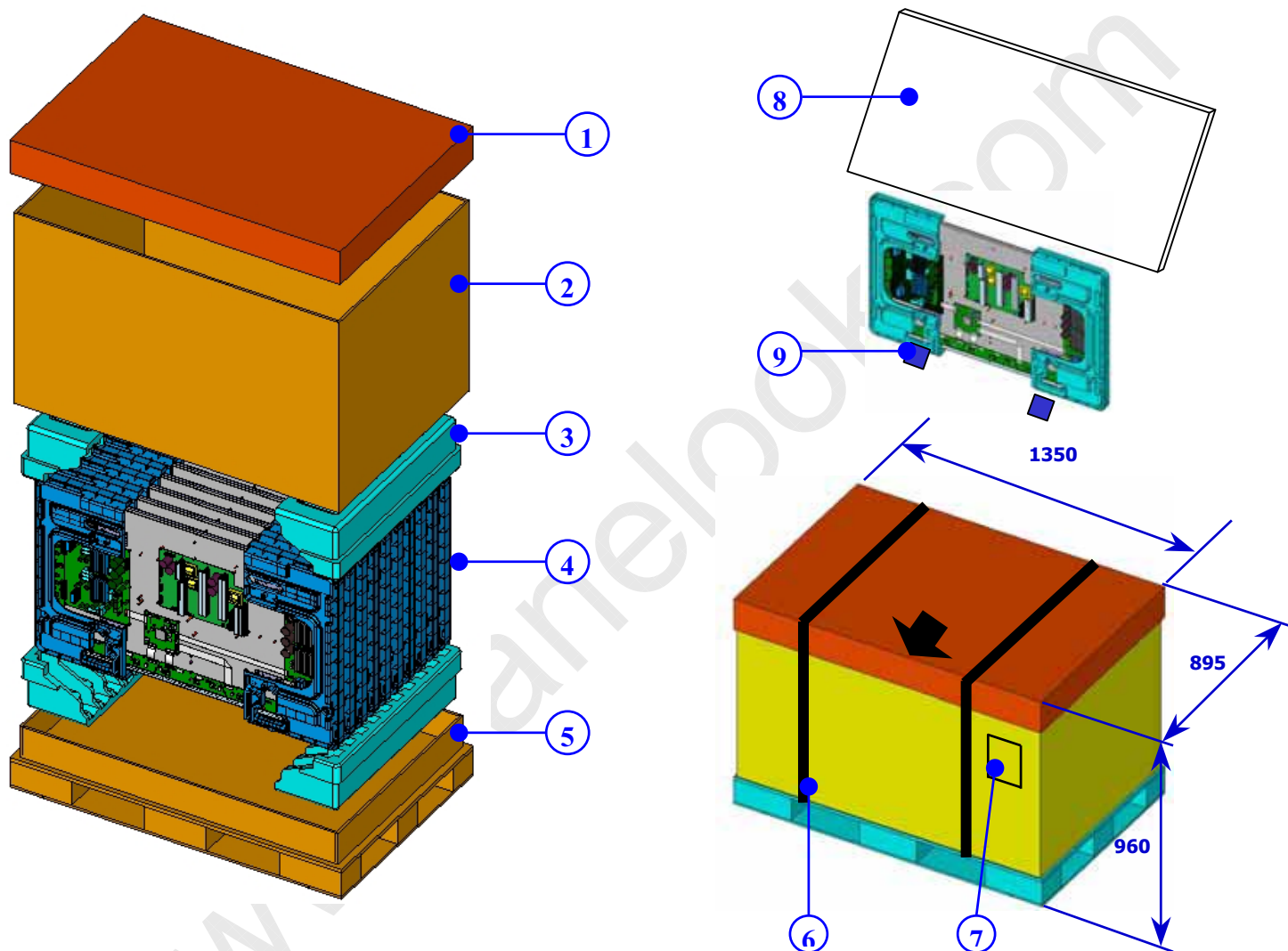

NO.	Item	NO.	Item
1	PACKING BOX- TOP	6	PP BAND
2	PACKING BOX- OUT	7	LABEL- INSPECTION
3	CUSHION- SET	8	BAG VINYL
4	PACKING- MODULE	9	CHEMICALS- CAO
5	PALLET- 4WAY		

14 RELIABILITY

14.1 Expected Service Life

14.1.1 Definition

The expected service life is defined by the following two categories.
And the life time is defined by either (1) or (2), whichever occurs first.

(1) The white color Luminance level becomes half (50%) of its initial value, which is determined by the phosphor characteristics.

(2) The number of display cell defects increases to double the specification value, which is depending on the discharge characteristics.

14.1.2 Test condition and life time

The expected service life time varies depending on the display conditions set forth below.

- (1) Test Condition : 8Hr/Day on full white pattern
- (2) Life Time : 60,000 hrs

14.2 Disclaimer

This Specification stipulates the final and comprehensive requirements for the respective products hereof. Beyond this Specification, it is the responsibility of the customer to explicitly disclose any additional requirements, information or reservations regarding these requirements to Samsung SDI prior to implementation, where any and all disclosures of the customer shall be with an authorized representative of Samsung SDI in writing. Samsung SDI shall not be responsible for safety, performance, functionality or compatibility of the system with which the Samsung SDI-supplied components are integrated unless such features have been expressly communicated and described in the Specification. SAMSUNG SDI MAKES NO GUARANTY OR WARRANTY, EXPRESS OR IMPLIED, INCLUDING BUT NOT LIMITED TO MERCHANTABILITY OR FITNESS FOR A PARTICULAR PURPOSE, TO ANY PARTY. Moreover, any party should do their own due diligence regarding these requirements prior to implementation

15 WARNING / CAUTION / NOTICE

TO PREVENT POSSIBLE DANGER, DAMAGE, AND BODILY HARM, PLEASE CONSIDER AND OBSERVE ALL WARNINGS AND CAUTIONS CONTAINED IN THIS PARAGRAPH.

15.1 Warning

If you do not consider the following warnings, it could result in death or serious injury

- (1) The Module is controlled by high voltage about 350V. If you need to handle the Module during operation or just after power-off, you must take proper precautions against electric shock and must not touch the drive circuit portion and metallic part of Module within 5 minutes. The capacitors in the drive circuit portion remain temporarily charged even after the power is turned off. After turning off the power, you must be sure to wait at least one minute before touching the Module. If the remain voltage is strong enough, it could result in electric shock.
- (2) Do not use any other power supply voltage other than the voltage specified in this product specifications. If you use power voltage deviated from the specifications, it could result in product failure.
- (3) Do not operate or install under the deviated surroundings from the environmental specification set for the below; in moisture, rain or near water-for example, bath tub, laundry tub, kitchen sink; in a wet basement; or near a swimming pool; and also near fire or heater - for example, near or over radiator or heat resistor; or where it is exposed to direct sunlight; or somewhere like that. If you use the Module in places mentioned above, it could result in electric shock, fire hazard or product failure.
- (4) If any foreign objects (e.g. water, liquid and metallic chip or dust) entered the Module, the power supply voltage to the Module must be turned off immediately. Also, never push objects of any kind into the Module as they may touch dangerous voltage point or make short circuits that could result in fire hazard or electric shock.
- (5) If smoke, offensive smell or unusual noise should come from the Module, the power supply voltage to the Module must be turned off immediately. Also, when the screen fails to display any picture after the power-on or during operation, the power supply must be turned off immediately. Do not continue to operate the Module under these conditions.
- (6) Do not disconnect or connect the Module's connector while the power supply is on, or immediately after power off. Because the Module is operated by high voltage, and the capacitors in drive circuit remain temporarily charged even after the power is turned off. If you need to disconnect or reconnect it, you have to wait at least one minute after power off.
- (7) Do not disconnect or connect the power connector by a wet hand. The voltage of the product may be strong enough to cause an electric shock.
- (8) Do not damage the power cable of the Module, also do not modify it.
- (9) When the power cable or connector is damaged or frayed, do not use it.

**SamsungSDI Corporation
Module****Specification****Plasma Display**

- (10) When the power connector is covered with dust, please wipe it out with a dry cloth before power on.

15.2 Caution

If you do not consider the following cautions, it may result in personal injury or damage in property.

- (1) Do not set the Module on an unstable, vibrating or inclined place. The Module may fall or collapse and it may cause a serious injury to a person, and/or damage to the product.
- (2) If you need to remove the Module to another place, you must turn off the power supply and detach the interface cable and power cable from the Module beforehand, and watch your steps not to step on the cables during the operation. If the cables are damaged during the transport, it may result in fire hazard or electric shock. Also if the Module is dropped or fallen, it may cause a serious injury to a person and /or damage to the product.
- (3) When you draw or insert the module's cable, you must turn off the power supply and do it (with) holding the connector. If you forcibly draw the cable, the electric wire in the cable can be exposed or broken. It may result in fire hazard or electric shock.
- (4) When you carry the Module, it should be done with at least two workers in order to avoid any unexpected accidents.
- (5) Be careful not to touch the panel glass surface while the PDP module is operating because there is a possibility of getting a burn injury due to its very high temperature.
- (6) The Module has a glass-plate. If the Module is inflicted with excessive stress - for example; shock, vibration, bending or heat-shock, the glass plate could be broken. It may result in a personal injury. Also, do not press or strike the glass surface.
- (7) If the glass panel was broken, do not touch it with bare hand. It may result in a cut injury.
- (8) Do not place any object on the glass panel. It may be the cause of the scratch or break of the glass panel.
- (9) Do not place any object on the Module. It may result in a personal injury due to fall or drop.
- (10) PDP is a product, which generates heat during operation. Therefore, do not use the materials which make corrode the PDP module by the chemical reaction that takes place in high temperature and humidity conditions.
- (11) Exposing to corrosive gases or contact with the materials, which may cause corrosions, could lead to chemical reactions that will adversely affect on the device. If you were to use the PDP in such conditions, consider ways to avoid such exposure or to protect the PDP module.

15.3 Notice

When you apply the Module to your system or handle it, you must make sure to follow the notices set forth below.

Notice to your system design

- (1) The Module radiates the infrared rays of between 800 and 1000 nm. It may bring an error in operating the IR-remote controller or another electric system. Please consider (to) providing the IR absorb filter in your system, and evaluating it.
- (2) The Module has a high-voltage switching circuit and a high-speed clock circuit. Therefore, you have to apply and evaluate the EMC consideration of your system.
- (3) The Module has a glass plate. In your mechanical design, please (consider to) avoid any excessive shock and stress to the glass surface. Also be careful not to damage the exhaust pipe at the corner of glass plate. If the glass plate and exhaust pipe are damaged, the &Module may fail.
- (4) Since PDP module is controlled by high voltage, all voltage should be discharged immediately after the power is turned off.
- (5) PDP module generates heat during operation. Heatproof design (radiation and ventilation) should be considered from design stage. If the PDP module is used out of the specified temperature range, it can result in a defect.
- (6) The ventilation design in your system should have a back-cover that is able to prevent moisture and dust from getting into the inside of the electric circuit, because the Module has high-density electric parts with high-voltage. If the driver circuit has condensation or dusts, it may cause a short circuit or dielectric breakdown.
- (7) If an excessive stress (more than specified absolute maximum ratings in the voltage, current, temperature etc.) is applied to the PDP module, it could cause a serious damage. Do not use the module out of the ratings.
- (8) Recommended usage condition of PDP module is limited to the general usage. Within this range, the electrical characteristics of all components are guaranteed. Semiconductors should be used within specified usage range. Usage out of the range will result in decrease of reliability and defects in devices. If the usage or operating condition is out of specification specified on the data sheet, it will be not covered from the guaranteed range. If you were to use the product in the environment not stated in the list, you should consult with SAMSUNG SDI prior to the usage.
- (9) When the PDP module shows fixed pattern, there are possibilities of having the image retention (the difference in brightness between turned-on and turned-off portion of screen due to the different temperature and discharge) and image sticking (the difference in brightness due to phosphor deterioration). To ensure the screen performance, we suggest using the visual display area of PDP module and performing the following methods.
 - A. If the customer is required to use the fixed pattern, reduce the maximum brightness as low as possible, change the position of the displayed area or display the screen saver or moving picture periodically.
 - B. If possible, change the displayed color to equalize the total displayed time for each cell.
- (10) In system design and evaluation process, you should consider the maximum brightness level (image retention and image sticking).
- (11) The PDP screen is displayed by image data signals and synchronized signals. If noise interferes with the signals, the PDP screen could be unstable. Thus, when you design, you should take measures to minimize the affects of noise

**SamsungSDI Corporation
Module****Specification****Plasma Display**

- (12) For preventing from occurring condensation that consists of small drops of water which form when warm water vapor in the air touches a cold surface such as a panel glass moved from cold condition, the module need to be left in the room temperature for minimum 8 hours in box condition before use.
- (13) The customer has to consider their packing box to prevent from occurring condensation during delivery to the End User from their packing material design stage.
- (14) SAMSUNG SDI PDP module is a product for the computer, office automation, other office supplies, industry and communication, measurement devices, personal and home appliances. However, if you need to use the PDP module in particular situations, such as defective or abnormal operations can directly affect human life, injuries and damages in property could be caused, and high level of reliability is required (aerospace equipments, nuclear control systems, vehicle controls, life-supporting medical devices, etc.), you should consult with SAMSUNG SDI beforehand. SAMSUNG SDI will not take any responsibility for the problems and defects occurred in the course of usage without prior approval of SAMSUNG SDI
- (15) Based on the requirements of the safety standard (UL, EN etc.), be sure to add the filter that come up to the impact test to the glass plate

□ Notice to the operation and handling of the Module

- (1) To prevent defect or failure, please check the cable connections and power-supply condition before power-on.
- (2) The Module is controlled by high voltage. Not only during operation but also immediately after power-off, do not disconnect or reconnect the Module's connector because it may result in failure. If you need to disconnect or reconnect, you have to wait at least one minute after power-off.
- (3) The Module is equipped with various protection circuits that automatically stop the Module operation, if an interface signal or the power voltage becomes abnormal during operation. If the Module stops suddenly during operation, please check the conditions of input signal or power source before restarting.
- (4) For the protection of the circuit, if an abnormal situation is occurred, the high output voltage will be shut down by (watching) the internal input voltage (V_s / V_a / V_{cc}). In this case, the Module power resetting is necessary to recover. There are also fuses in the V_s and V_a power supply system to prevent smoking and firing by the excessive current. The protecting function of the address driver of keeping a supervisory device for the internal current is provided in the V_a power supply system. Therefore, the number of sub-frames decreases to a proper value when the I_a current exceeds a constant value occasionally.
- (5) If an abnormal situation such as disconnecting of the input connector occurs, this Module will be on stand-by, which the supply of high output voltage is stopped even if an external power is being supplied. If a normal signal is inputted after this, normal operation state, operations can be restarted again by re-inputting a normal signal. However, it is necessary to rest the Module power when t_{VH} and/or t_{HV} are less than the minimum value provided in the specification
- (6) To ensure reliable operation of the Module and to protect it from overheating, do not wrap or cover it with a cloth or like a sheet during power-on period. Also, do not place the Module in a confined space or any other places of poor ventilation.
- (7) If you continue to watch the naked screen (without filter glass) for a long time, your eyes could be fatigued. We recommend you rest your eyes occasionally. However,

**SamsungSDI Corporation
Module****Specification****Plasma Display**

- according to the information currently available, watching PDP module for a long time does not cause a direct harm to your eyes.
- (8) The screen is controlled with the display-data signals and synchronized signals. If noise interferes with those signals, the screen could become unstable and, in some case, would cause a failure. Do not place any equipment that generates excessive EMI/RFI noise near the interface cable of the Module, and keep the cables as short as possible.
 - (9) Be careful not to break the glass panel when you handle the Module. Also, when handling the Module, you must wear gloves or other hand protection to prevent injuries that can occur in case when the glass panel is broken.
 - (10) The glass panel section and drive circuit section of the Module are closely connected and they function as a pair. If the Module is arbitrarily recombined, restructured, or disassembled, SDI will not be responsible for the function, quality, or operational integrity of the modified Module. Do not recombine, restructure, or disassemble it. (Only, the Module for A/S is allowed to be recombined, restructured, or disassembled.)
 - (11) To avoid a possible electric shock, you must make sure that the power supply voltage of Module is turned off before cleaning. To clean the module's glass panel, apply water or a natural detergent to a piece of soft cloth or gauze, and wring the cloth tightly before wiping the screen. Make sure that no water comes in contact with the connecting terminals on the side of the glass panel. Do not use chemical solvents, such as paint thinner or benzene, to clean the glass panel.
 - (12) The drive circuit section of Module uses C-MOS integrated circuits that must be protected from static electricity. Therefore, when transporting or delivering the Module, be sure to put the Module in an antistatic bag. When handling the Module, take adequate grounding precautions to prevent static electricity.
 - (13) When delivering or transporting the Module, you must take special precautions because excessive vibration or shock should not be applied to it. If the Module is dropped, or (if) excessive vibration/shock is applied, the glass panel of the Module may be broken and the drive circuit may be damaged. The packing for delivering or transporting should be made with strict instructions.
 - (14)The information and schematics shown in this specification are just examples of display applications; it does not mean that they must be applied to your device for the actual use. SAMSUNG SDI does not take any responsibility for the infringement of patent or any other intellectual rights arising from the use of the information or schematics in the document.
 - (15)If any part or technology of the product described in this specification become subject to restrictions on export or any related laws or regulations, a prior permission is required before exporting.
 - (16) The PDP module uses semiconductor devices. Since semiconductors are very sensitive to static electricity, the following requirements should be conformed during delivering, transferring and handling the PDP module: Remove the static electricity on your body by wearing the earth-ring which must be connected to the ground through high resistor (about 1M Ohm). It is recommended to wear the conductive clothes and shoes, use conductive floor mats, and take other measures to minimize the static electricity. All the equipments and tools must be connected to the ground and protected from static electricity. When you deliver or transfer the PDP module, always use anti-static bag.
 - (17) If any device that can generate the high-voltage is located nearby the PDP module, it could cause an abnormal operation. In such a case, you should take a countermeasure to prevent against static electricity and discharges.
 - (18) If the PDP module is exposed to corrosive gases or contacted to oil, it could cause chemical reactions and give unfavorable effects on the devices. If you intend to use the

**SamsungSDI Corporation
Module****Specification****Plasma Display**

PDP module under such conditions, you must consider the ways to avoid exposure or to protect the PDP module before using it.

- (19) The PDP module is not designed to endure radiation or cosmic radiation. Users must install the proper shielding.
- (20) The PDP module uses thermo-plastic devices. Since these devices are easy to be damaged, do not use the PDP module nearby inflammable substances. If they are burnt, poisonous gas will be emitted.
- (21) To ensure the normal operation of the PDP module, the recommended operating range should be required. The electrical properties of the PDP module are guaranteed only when it is used within the recommended operating range. The PDP module must be used within the range at all time. If you use it out of the range, it could give adverse effects on its reliability or cause defects.
- (22) Flexible cables connect electrodes on the panel glass and PCBs. Thus, do not apply too much stress such as shock, vibration, pressure, or bending, to the surface of panel glass, PCBs and flexible cables.
- (23) If there is no special notice, the contents of this specification describe the product with the initial parameters after shipment.
- (24) Even if the panel glass is cleaned before shipping, there is a possibility of particle remained on the panel. In this case, remove it prior to the usage. When you clean the surface of the panel glass, use a piece of soft cloth with detergent to wipe off. Do not use any chemical substances such as acid, alkali or organic detergent.
- (25) The Module is composed of various kinds of materials such as glass, metals and plastics. A qualified service technician is required for the disposal of the Module.

□ Notice to the storage of the Module

- (1) When storing the Module, you must select an environmentally controlled place. Avoid any environment in which the temperature or humidity exceeds the specification values. If you are storing it for a long period of time, we recommend that you place the Module together with a dehumidifying agent, such as silica gel, in a moisture-proof bag and keep it in an environmentally controlled place.
- (2) If the module is stored for a long time, the discharge might not take place smoothly. In this case, aging approximately for minimum 2 hours with a full white pattern is suggested. Do aging once in every 6 months.
- (3) Do not place the PDP module in the environment with a rapid temperature change in order to avoid the condensation inside of the module.
- (4) Do not open the packages at dusty place or the place where corrosive gases exist.
- (5) Only qualified person can transfer the PDP module with a forklift or crane.

□ Notice to the repairing and fixing of the Module

The PDP module is a product made with various tests and adjustments hence, repairing and fixing of PDP module is not allowed to conduct at customer's place. The issue must be handled separately from the specifications.

□ Notice of the Module performance

The Module is the newest display device utilizing the gas discharge technology and digital signal processing technology, and its performances are mostly similar to those of CRT. However, some display performances of the PDP module are different from the CRT's. Please consider the following notices when you watch the screen.

**SamsungSDI Corporation
Module****Specification****Plasma Display**

- (1) There is (a) slight Neon luminance shown outside of the effective display area on the glass panel. Conceal these parts so that it may not be seen on the display surface.
- (2) Depending on the type and time of usage, there may be a slight change in the Luminance and color. There may be an increase of both X-value and Y-value by 0.05 at the maximum in chromaticity. In this case, adjust it using the external data signal.
- (3) Because the Module uses phosphor to emit a light, the phosphor, like a CRT, will be deteriorated in proportion to the display signal and Luminance settings. If the same pattern is displayed continuously (fixed display) for an extended period of time, the Luminance of that area will be decreased over non-lit areas due to the fact that the discharge surface will be more activated comparing to the other areas.
- (4) When the Vsync signal timing becomes shorter right after the changing of Vsync frequency (e.g. from 50 Hz to 60Hz / from 60 Hz to 70 Hz) depending on the Multi-Vsync function, an initial Vsync signal of the changed frequency will be disregarded and the screen will be interrupted for 1 frame period in maximum.
- (5) Because the Module is a digital processing display device, this Module is equipped with the Error diffusion technology and a Duplicated Sub-Frame method to display the grayscale and false contour improvement. However, you may sometimes find a color false contour, especially in human facial contour, in moving picture due to the difference of display performance comparing to the TV-tube.
- (6) If the Module displays some video test patterns that are mostly used in a laboratory or inspection process of the manufacturing facilities, you may find the following subjects. But these subjects should not be recognized in the failure or defects because the display performance of the Module is equipped with Error diffusion technology and Duplicated Sub-Frame method (for PAL) based on digital processing technique.
 - A. Linearity in the grayscale test pattern
If the PDP module displays the grayscale test pattern (e.g. white color Luminance is gradually changed horizontally or vertically) in a screen, you may find the disparity of Luminance at adjacent grayscale patterns. This behavior is caused by duplicated sub-frame condition (for PAL), display load correction and electroad dependency.
 - B. Color contouring and dithering at the stationary picture
If the stationary picture such as a human face or the like is shown in the screen, you may feel some unstable noise at the contour area. This behavior is called the color contouring or dithering, and is caused by the error diffusion condition, display load correction and electroad dependency.
- (7) If the Module is operated under inadequate conditions or harsh environment, the screen may become unstable or noisy. This instability is mostly related to ambient temperature, air pressure, input signal instability (include signal noise), input power voltage and strong magnetic field such as MRI/NMR application or superconducting magnet application. Please do not apply the Module to inadequate conditions or harsh environment mentioned above.

□ PDP DESIGN GUIDELINES AGAINST CORROSIVE GASES/HIGH HUMIDITY

During the PDP development stage , some materials which may generate corrosive gas(es) or ions such as sulfur, sodium, and chlorine, etc must not be allowed to use in the modules.

If the material mentioned above is used or located close to the address terminals, chemical reaction may occur and cause the modules to fail.

**SamsungSDI Corporation
Module****Specification****Plasma Display**

If customer wishes to use some materials due to unavoidable cause, then safe gap between address terminals and the material(s) which may generate corrosive gas(es) is minimum 5mm or customer must keep or deliver PDP always in room temperature and room humidity state at any cases. It is a mandatory guide line to protect the modules from corrosive gases or ions.

If some material contains sulfur (sulfur), Sodium (sodium) and Chloride, then Samsung SDI strongly suggests customer to keep the guidelines. The weight of material containing sulfur must be no more than 300ppm. The analysis of the sulfur weight is based on the normalized "ICP-AES" method.

□DISCLAIMER

This Specification stipulates the final and comprehensive requirements for the respective products hereof. Beyond this Specification, it is the responsibility of the customer to explicitly disclose any additional requirements, information or reservations regarding these requirements to Samsung SDI prior to implementation, where any and all disclosures of the customer shall be with an authorized representative of Samsung SDI in writing. Samsung SDI shall not be responsible for safety, performance, functionality or compatibility of the system with which the Samsung SDI-supplied components are integrated unless such features have been expressly communicated and described in the specification. SAMSUNG SDI MAKES NO GUARANTY OR WARRANTY, EXPRESS OR IMPLIED, INCLUDING BUT NOT LIMITED TO MERCHANTABILITY OR FITNESS FOR A PARTICULAR PURPOSE, TO ANY PARTY. Moreover, any party should do their own due diligence regarding these requirements prior to implementation.

16 ADDITIONAL SPECIFICATIONS

16.1 Opto-Electric Specifications

ITEM	Condition	60Hz	Unit
Color Temperature	Full white	8,000	K
Color Coordinate	F/White	x	0.285
		y	0.293
Brightness Uniformity	Full white ((Max-A5)/A5)	15	%
Chromaticity Uniformity	Full white	0.015	-

NOTE The values in Table is typical ones.

16.2 Environmental Performance

ITEM	Operation Range
Air Pressure	795 ~ 1013 hPa

16.3 Cell Defects

16.3.1 Classification

Cell defects are classified as follows:

- (1) Non-lighting cell defect ... cell which is always off
- (2) Non-extinguishing cell defect ... cell which is always on
- (3) Flickering cell defect ... cell which is flickering
- (4) High intensity cell defect ... cell which is brighter than a correct cell

16.3.2 Specifications

- (1) Measuring pattern : Full white, red, green and full blue pattern
- (2) Display zone specification

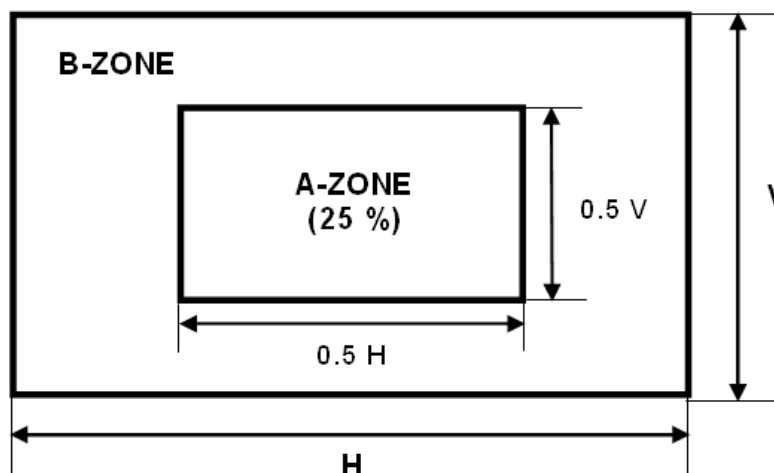

Figure 9 - Display zone



**SamsungSDI Corporation
Module**

Specification

Plasma Display

(3) Cell defects specification

Item	Number of cell defects		Remark
	A Zone	B Zone	
Non-lighting cell	4 and less	9 and less	Distance between defect cells should be 15mm over.
Non-extinguishing cell	2	3 and less	
Flickering cell	2	3 and less	
Two continuous cell	1	2 and less	
Total defect	13 and less		

APPENDIX

A MEASURING METHOD

A.1 Optical Characteristic

A.1.1 Measuring Condition

- (1) Room Condition : Dark room of 2lx under at ambient temperature, 25 °C
- (2) Vsync : 16.7 ms or 20ms
- (3) Equipment : MINOLTA CA-100+, BM7 for viewing angle
VG-828 (Pattern Generator)

A.1.2 Peak Brightness, Bp

Peak brightness, Bp should be measured within 5sec after turn-on on center white box in Figure 1 below.

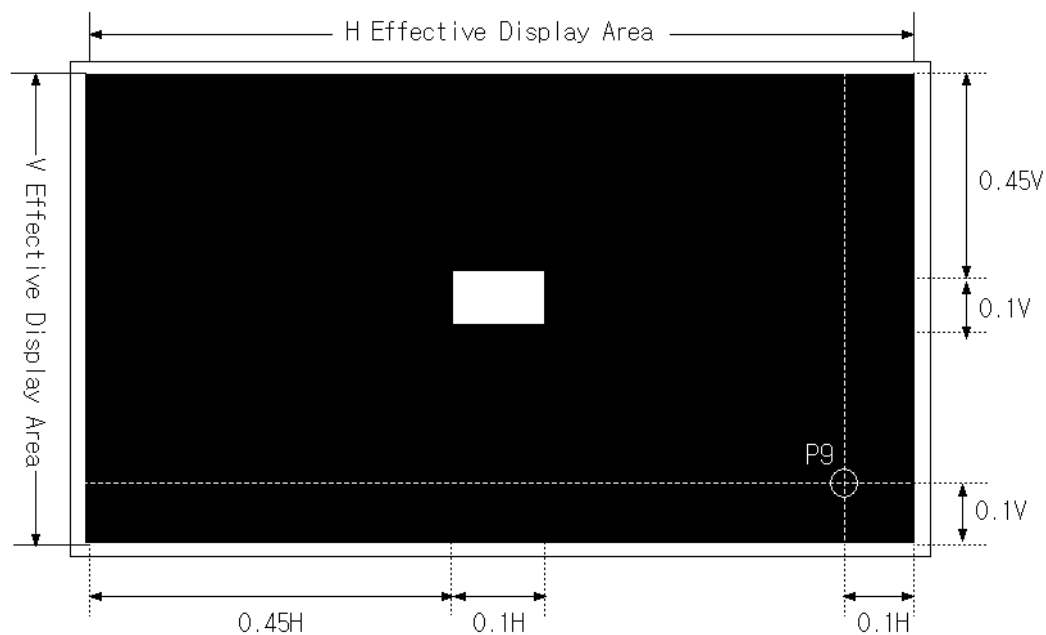

Figure A.1 – Measuring pattern for Bp and DRCR

A.1.3 Dark Room Contrast Ratio (DRCR)

The dark room contrast ratio DRCR is defined as follows:

$$DRCR = \frac{Bp}{Bb}^1$$

¹ Bb is the black brightness on point P9 in figure A.1.