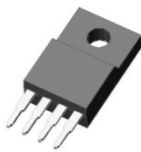

TO-252-5L

TO-220F-4SL

Description

The S52Dxxx is an efficient linear low dropout voltage regulator for various electronic equipment. It is designed to provide very low dropout voltage, and better than 2.4% output voltage accuracy.

And the S52Dxxx has various key features such as current limiting, over temperature shut-down, over voltage protection, enable pin, and low noise performance with an low noise option.

Furthermore, it is available in adjustable or fixed output voltages in SOP-8, TO-252-5L, TO-220F-4SL packages.

Application

- ◆ Consumer and personal electronics
- ◆ SMPS post-regulator / dc-to-dc modules
- ◆ High-efficiency linear power supplies

Features and Benefits

- ◆ Low Dropout Voltage for 1.0A Output : [Max. 500mV].
- ◆ Built in Thermal shut down circuit.
- ◆ Built in OVP, CLP circuit.
- ◆ Low Quiescent Current : [Typ. 2.0mA]
- ◆ Ultra High level of ESD [Built in ESD Protection Cell]
MM : 400V ↑ / HBM 3KV ↑

ORDERING INFORMATION

Product	Marking	Package
S52DxxD	S52DxxD	TO-252-5L
S52DxxPIC	S52DxxPIC	TO-220F-4SL

▲ Marking Detail Information

[TO-220F-4SL & TO-252-5L PKG Marking]



- ① AUK Logo
- ② Grade & M Code & Year & Week Code
- ③ Device Code

Equivalent Circuit

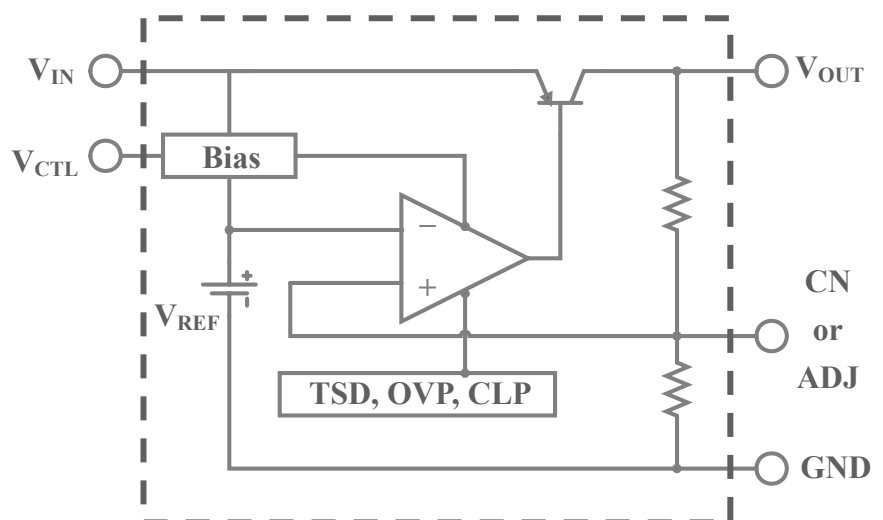

◆ Pin Configuration

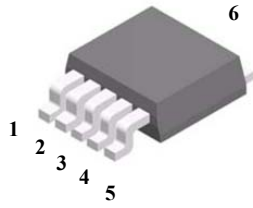

TO-252-5L

- 1: V_{IN}
- 2: V_{CTL}
- 3: V_{OUT}
- 4: ADJ/CN
- 5: GND
- 6: V_{OUT}

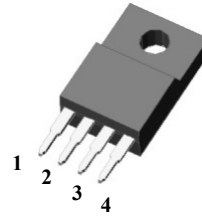

TO-220F-4SL

- | Fixed V_{OUT} | ADJ V_{OUT} |
|-----------------|---------------|
| 1: V_{IN} | 1: V_{IN} |
| 2: V_{OUT} | 2: V_{OUT} |
| 3: GND | 3: GND |
| 4: V_{CTL} | 4: ADJ |

◆ Product Line-up

Product Name	V_{OUT}	Operating Temperature	Package
S52D00D	ADJ.	-30~125°C	TO-252-5L
S52D18D	1.8V	-30~125°C	TO-252-5L
S52D25D	2.5V	-30~125°C	TO-252-5L
S52D33D	3.3V	-30~125°C	TO-252-5L
S52D50D	5.0V	-30~125°C	TO-252-5L
S52D00PIC	ADJ.	-30~125°C	TO-220F-4SL
S52D18PIC	1.8V	-30~125°C	TO-220F-4SL
S52D25PIC	2.5V	-30~125°C	TO-220F-4SL
S52D33PIC	3.3V	-30~125°C	TO-220F-4SL
S52D50PIC	5.0V	-30~125°C	TO-220F-4SL

◆ **Absolute Maximum Ratings (Ta = 25°C)**

Parameter		Symbol	Limits	Unit
Input Voltage		V _{IN}	23.0	V
Power Dissipation	SOP-8	P _d	0.6(Note1)	W
	TO-220F-4SL		2.0(Note1)	
	TO-252-5L		1.5(Note1)	
Junction Temperature		T _J	150	°C
Operate Temperature Range		T _{opr}	-30 ~ +125	°C
Storage Temperature Range		T _{stg}	-55 ~ +150	°C

Note 1 : No Heat-sink

Absolute maximum ratings indicate limits beyond which damage to the component may occur. Electrical specifications do not apply when operating the device outside of its operating ratings. The maximum allowable power dissipation is a function of the maximum junction temperature, T_{J(max)}, the junction-to-ambient thermal resistance, θ_{JA}, and the ambient temperature, T_A.

The maximum allowable power dissipation at any ambient temperature is calculated using:

PD(max) = (T_{J(max)} - T_A) ÷ θ_{JA}. Exceeding the maximum allowable power dissipation will result in excessive die temperature, and the regulator will go into thermal shutdown.

◆ **Guaranteed Operating Conditions (Ta = 25°C)**

Parameter	Symbol	Limits	Unit
Supply Input Voltage	V _{IN}	V _O +0.5~20	V
Enable Input Voltage	V _{CTL}	0~ V _{IN}	V
Output Current	I _{OUT}	0~ 1.0	A

◆ Electrical characteristics

($V_{IN}=V_{OUT}+1.0V$, $C_{IN} = 0.33\mu F$, $C_{OUT} = 47 \mu F$, $I_{OUT} = 5mA$, $T_J=25^\circ C$; unless noted)

NO	Characteristics		Symbol	Condition	Specification			Unit
					MIN.	TYP.	MAX.	
1	Output Voltage	S52D00x	V_{OUT}	Variation from nominal V_{OUT}	1.215	1.240	1.265	V
		S52D18x			1.764	1.800	1.836	V
		S52D25x			2.450	2.500	2.550	V
		S52D33x			3.234	3.300	3.366	V
		S52D50x			4.900	5.000	5.100	V
2	Line Regulation		V_{LINE}	$V_{IN}=V_{OUT}+1V$ to 12V, $I_{OUT}=5mA$	-	0.05	0.5	%
3	Load Regulation		V_{LOAD}	$V_{IN}=V_{OUT}+1V$, $I_{OUT}=5mA$ to 1A	-	0.1	1.0	%
4	Quiescent Current		I_{QC}	$V_{IN}=V_{OUT}+1V$ to 20V, $I_{OUT}=0mA$	-	2.0	5.0	mA
5	Ripple Rejection		$R \cdot R$	$I_{OUT}=50mA$, $f=120Hz$	53.0	65.0	-	dB
6	Dropout Voltage		V_{DROP}	$I_{OUT}=1.0A$	-	-	0.5	V
7	Current Limit		I_{LIMIT}	$V_{IN}=V_{OUT}+1V$	1100	1300	-	mA
8	Output Noise Voltage		V_{NO}	$V_{IN}=V_{OUT}+1V$, $I_{OUT}=50mA$, $10Hz \leq f \leq 100kHz$	-	100	-	μV_{rms}
9	Output On state for V_{CTL}		$V_{CTL(ON)}$	-	2.0	-	-	V
10	Output OFF state for V_{CTL}		$V_{CTL(OFF)}$	-	-	-	0.8	V
11	Output On state for I_{CTL}		$I_{CTL(ON)}$	$V_{CTL}=2.0V$	-	-	20	μA
12	Output OFF state for I_{CTL}		$I_{CTL(OFF)}$	$V_{CTL}=0.8V$	-	-	0.1	μA

Typical Application

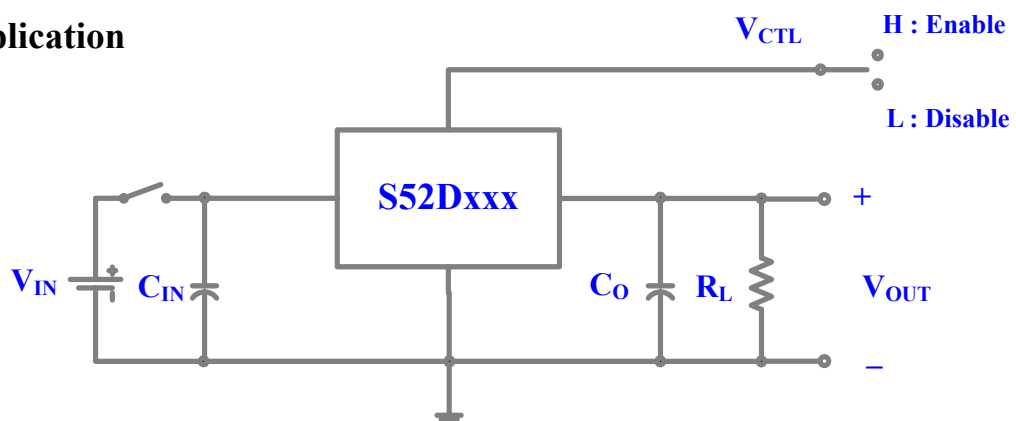

- 1) C_{IN} should be required if regulators are located far from power supply filter
- 2) C_O improves output stability and transient response ($C_O \geq 47\mu F$)

Fig1. $I_{QC} - T_J$

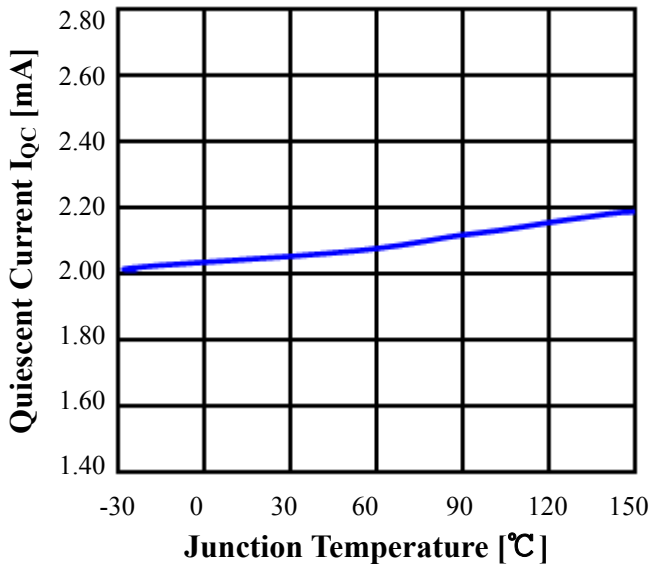

Fig2. $V_{OUT} - T_J$

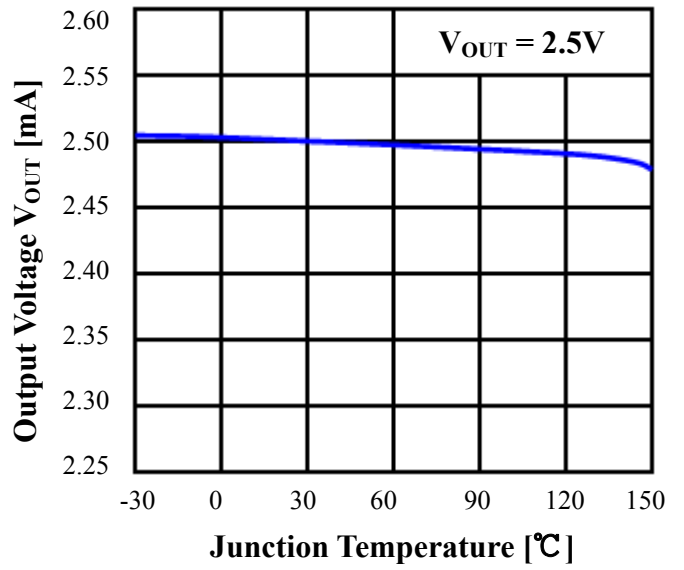

Fig3. $V_{OUT} - V_{IN}$

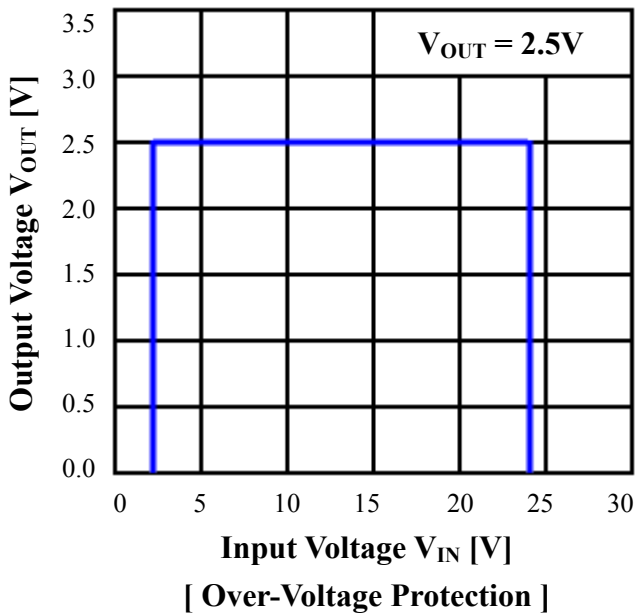

Fig4. $V_{OUT} - T_J$

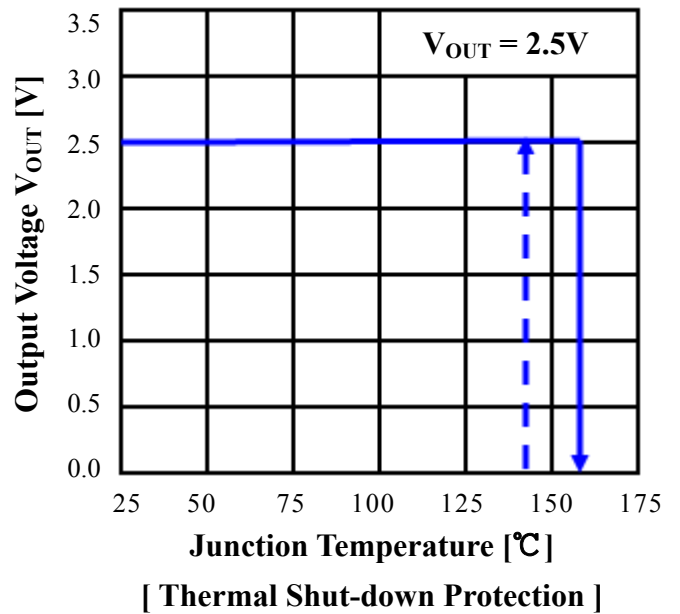

Fig5. $V_{OUT} - I_{OUT}$

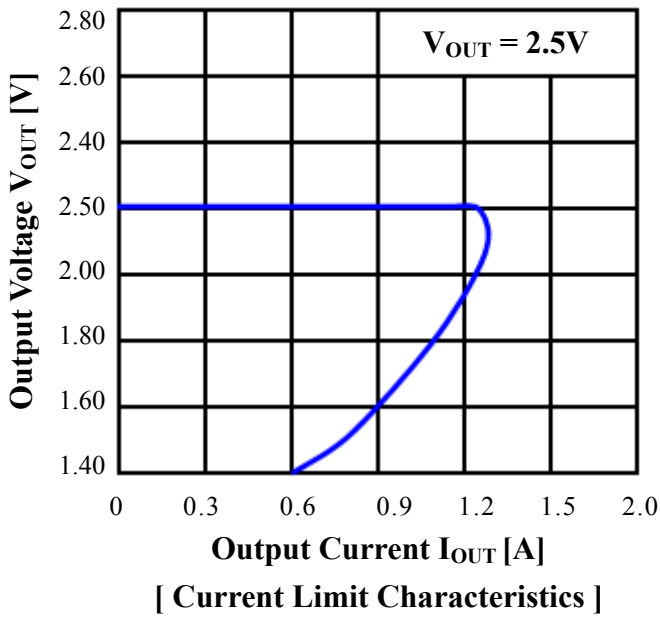

Fig6. $V_{OUT} - T_J$

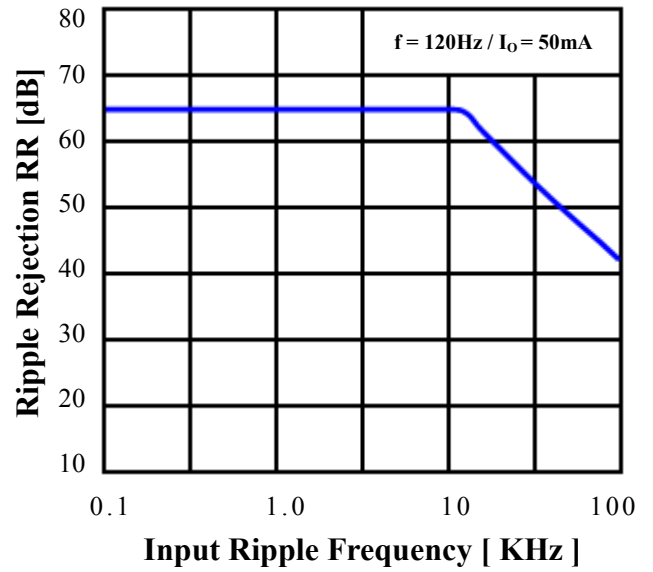

Fig7. $V_{DROP} - T_J$

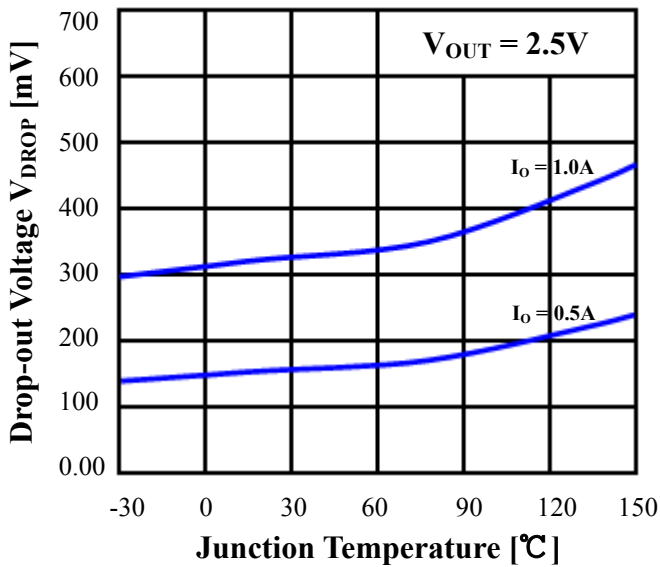

Fig.8 Line Transient Response

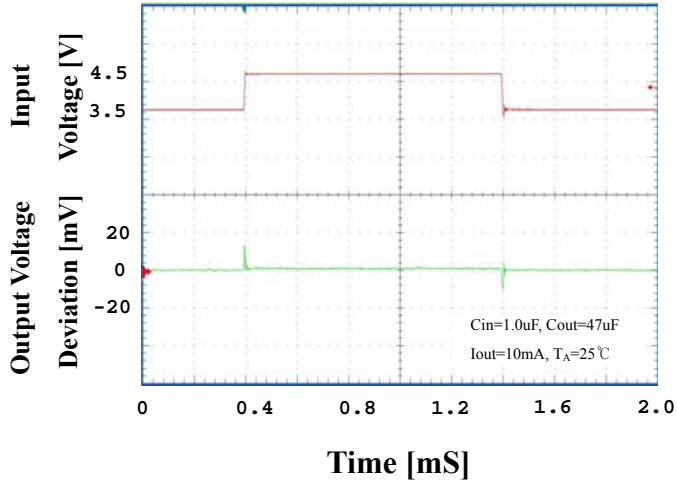

Fig.9 Line Transient Response

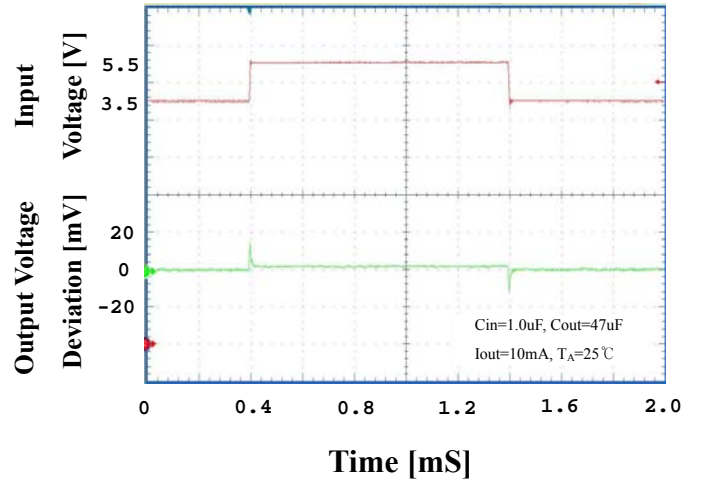

Fig.10 Load Transient Response

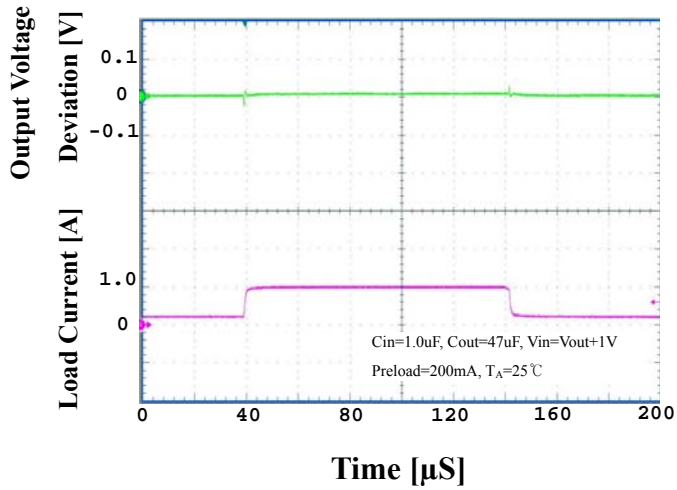
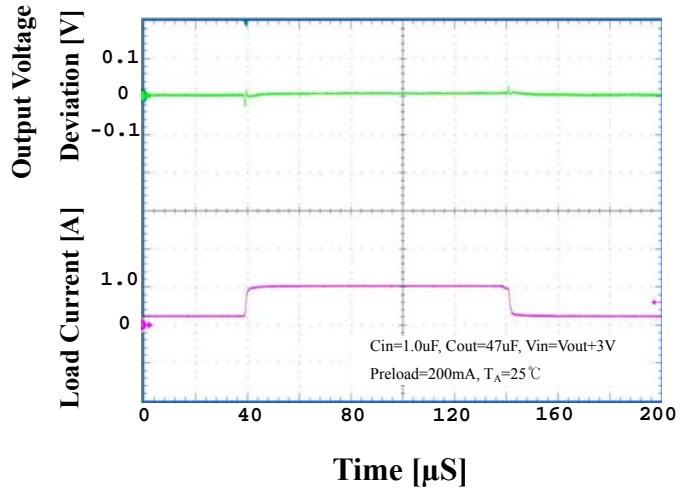
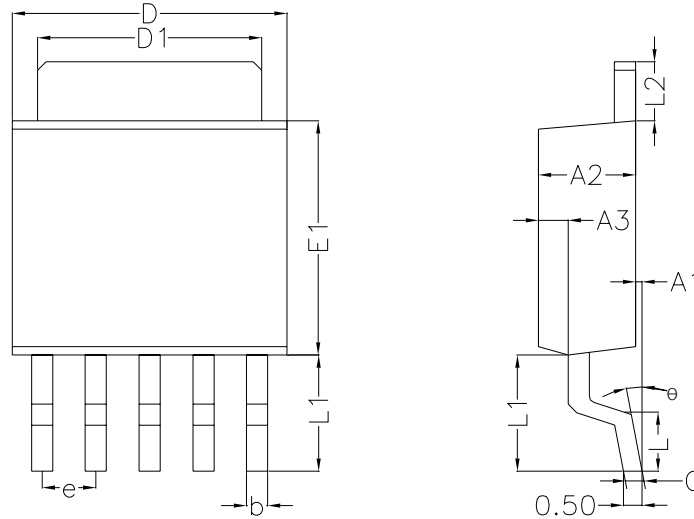

Fig.11 Load Transient Response



◆ TO-252-5L Outline Dimension (Unit : mm)



SYMBOL	MILLIMETER(mm)			NOTE
	MINIMUM	NOMINAL	MAXIMUM	
A1	0.05	0.15	0.25	
A2	2.10	2.30	2.50	
A3	0.50	0.60	0.70	
b	0.46	-	0.60	
C	0.49	-	0.56	
D	6.30	6.50	6.70	
D1	5.30REF			
E1	5.30	5.50	5.70	
e	1.27BSC			
L	1.40	1.50	1.60	
L1	3.00	3.10	3.20	
L2	1.40BSC			
θ	0 °	-	8 °	

※ Recommend PCB solder land [Unit: mm]

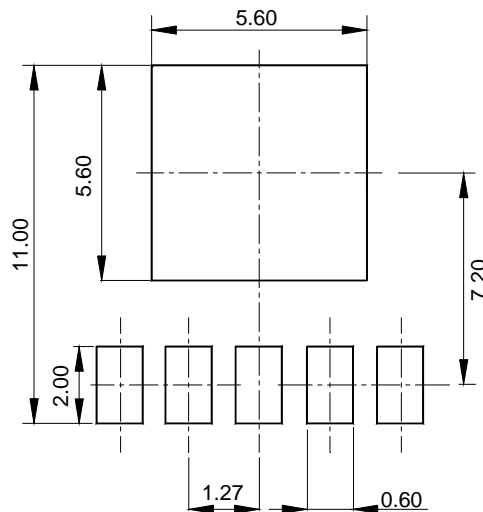

◆ TO-220F-4SL Outline Dimension (Unit : mm)

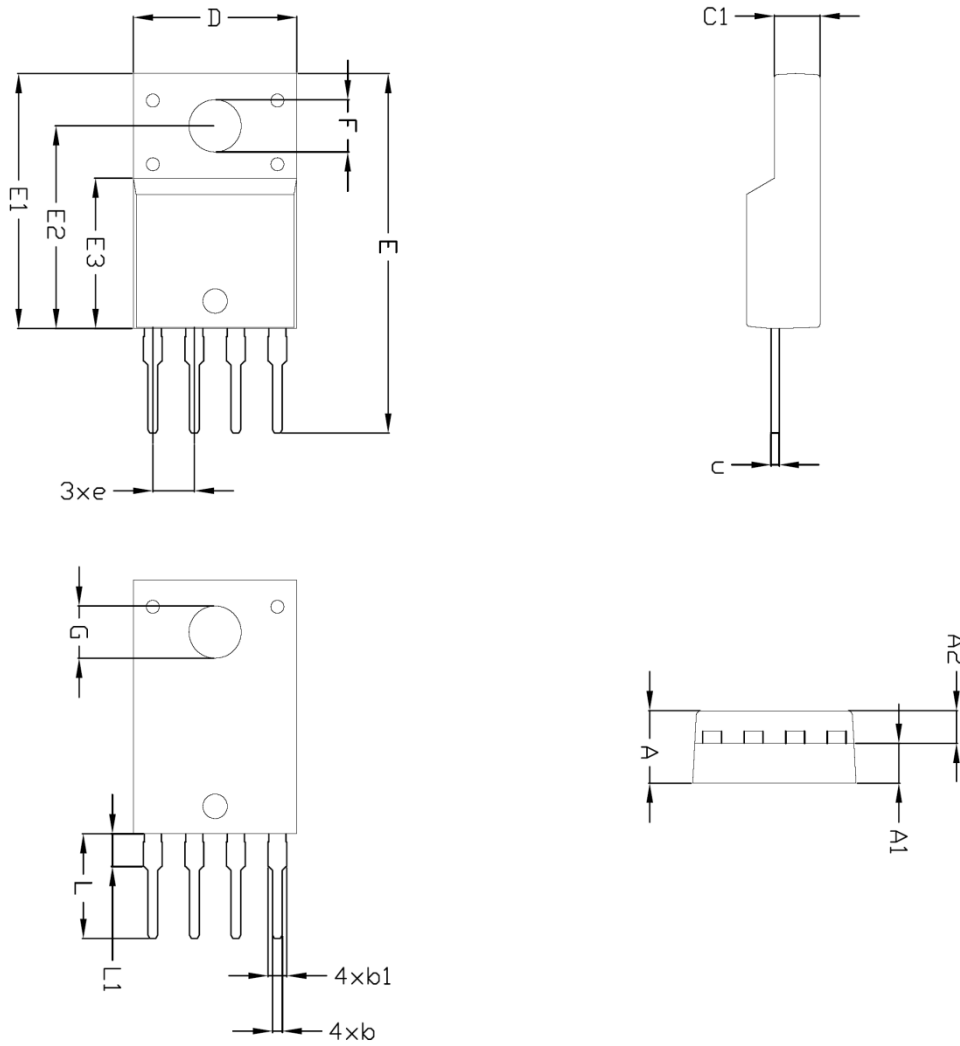

SYMBOL	MILLIMETERS			NOTE
	MINIMUM	NOMINAL	MAXIMUM	
A	-	-	4.60	
A1	2.45	2.50	2.55	
A2	1.95	2.00	2.05	
b	0.50	0.60	0.70	
b1	0.85	1.05	1.25	
c	0.40	0.50	0.60	
c1	2.70	2.80	2.90	
D	9.90	10.00	10.10	
E	20.80	-	21.40	
E1	15.50	15.60	15.70	
E2	12.30	12.40	12.50	
E3	9.15	9.20	9.25	
F	3.10	3.20	3.30	
G	3.30	3.40	3.50	
e	2.54 BSC			
L	5.20	-	5.80	
L1	2.00 BSC			

The AUK Corp. products are intended for the use as components in general electronic equipment (Office and communication equipment, measuring equipment, home appliance, etc.).

Please make sure that you consult with us before you use these AUK Corp. products in equipments which require high quality and / or reliability, and in equipments which could have major impact to the welfare of human life(atomic energy control, airplane, spaceship, transportation, combustion control, all types of safety device, etc.). AUK Corp. cannot accept liability to any damage which may occur in case these AUK Corp. products were used in the mentioned equipments without prior consultation with AUK Corp..

Specifications mentioned in this publication are subject to change without notice.