

S5N8952X

ADSL Transceiver for NIC

Preliminary Information
(Revision 2.0)

September. 2000

SAMSUNG ELECTRONICS CONFIDENTIAL PROPRIETARY

Copyright ©1999-2000 Samsung Electronics, Inc. All Rights Reserved



Contents

1. Features.....	5
2. General Description.....	5
3. Logical Symbol Diagram	6
4. Pin Configuration.....	7
5. Pin Description.....	8
6. Functional Description.....	13
7. I/O Timing Description.....	14
8. Electrical Characteristics.....	16
9. Package Description.....	17



List of Figures

Figure 1: General Block Diagram.....	5
Figure 2: Logical Symbol Diagram of the S5N8952X.....	6
Figure 3: Pin Configuration of the S5N8952X	7
Figure 4: Functional Block Diagram of the S5N8952X.....	13
Figure 5: AFE Data I/F Timing Diagram.....	14
Figure 6: AFE Control I/F Timing Diagram	14
Figure 7: PCI I/F Timing Diagram	15
Figure 8: 208-LQFP Package Diagram	17



List of Tables

Table 1: Pin Description of the S5N8952X	8
Table 2: Absolute Maximum Ratings.....	16
Table 3: Recommended Operating Conditions	16
Table 4: Power Dissipation.....	16
Table 5: DC Characteristics	16

1. Features

- Full Compliance with **T1.413 Issue-2**, ITU-T **G.992.1** (G.dmt) and **G.992.2** (G.lite).
- FDM and EC-based **DMT** Line Coding
- Data Rate: over **8Mbps** for Downstream and **640 Kbps** for Upstream.
- Reach: **6.7 Km** (22Kft) with **24 AWG** and **5.5 Km** (18 Kft) with **26 AWG**
- Supports **Rate Adaptive Mode** (steps of 32kbps)
- Reed-Solomon **Forward Error Correction** with(or without) **Interleaver**
- Adaptive Frequency and Time Domain **Equalizer**.
- **Trellis Coding** and **Echo Cancellation**.
- Supports **Normal** or **Reduced Overhead Framing** Modes
- Supports **Analog** and **Digital PLL**.
- Compatible to **PCI V2.2**
- Handle **ATM Cells (On-Chip SAR and Connection Memory)**
- Supports **Fast Retraining** Function in G.lite Mode
- Supports **Network Management** Function
- Supports **Power Management** Function
- **0.18mm, 1.8V** CMOS Technology
- Operating Temperature: **-40 °C to 85 °C**
- Package Type: **208-LQFP**

2. General Description

The S5N8952X is a complete ATM-based ADSL modem solution with associated F/W and an Analog Front-End (S5N8951). The S5N8952X provides all the digital functions such as PCI I/F, SAR, ATM framing, channel codec, DMT modulation, and DSP control.

There are two interfaces for external communications; PCI bus interface for NIC applications and AD/DA interface. The S5N8952X is optimized for providing NIC solution for CPE, and uses 17.664MHz Xtal oscillator as a master clock.

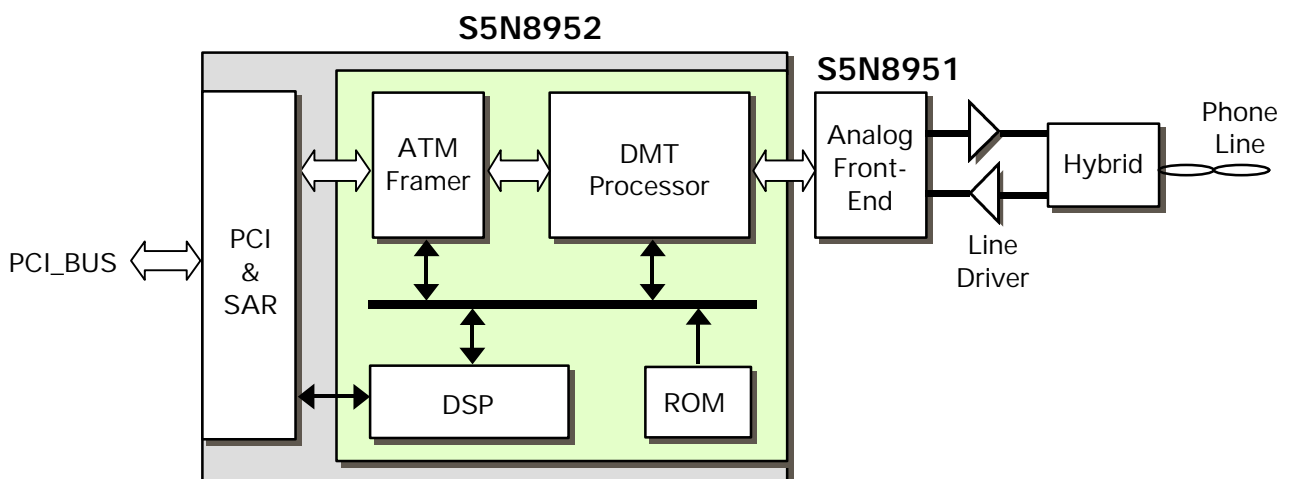

Figure 1: General Block Diagram

3. Logical Symbol Diagram

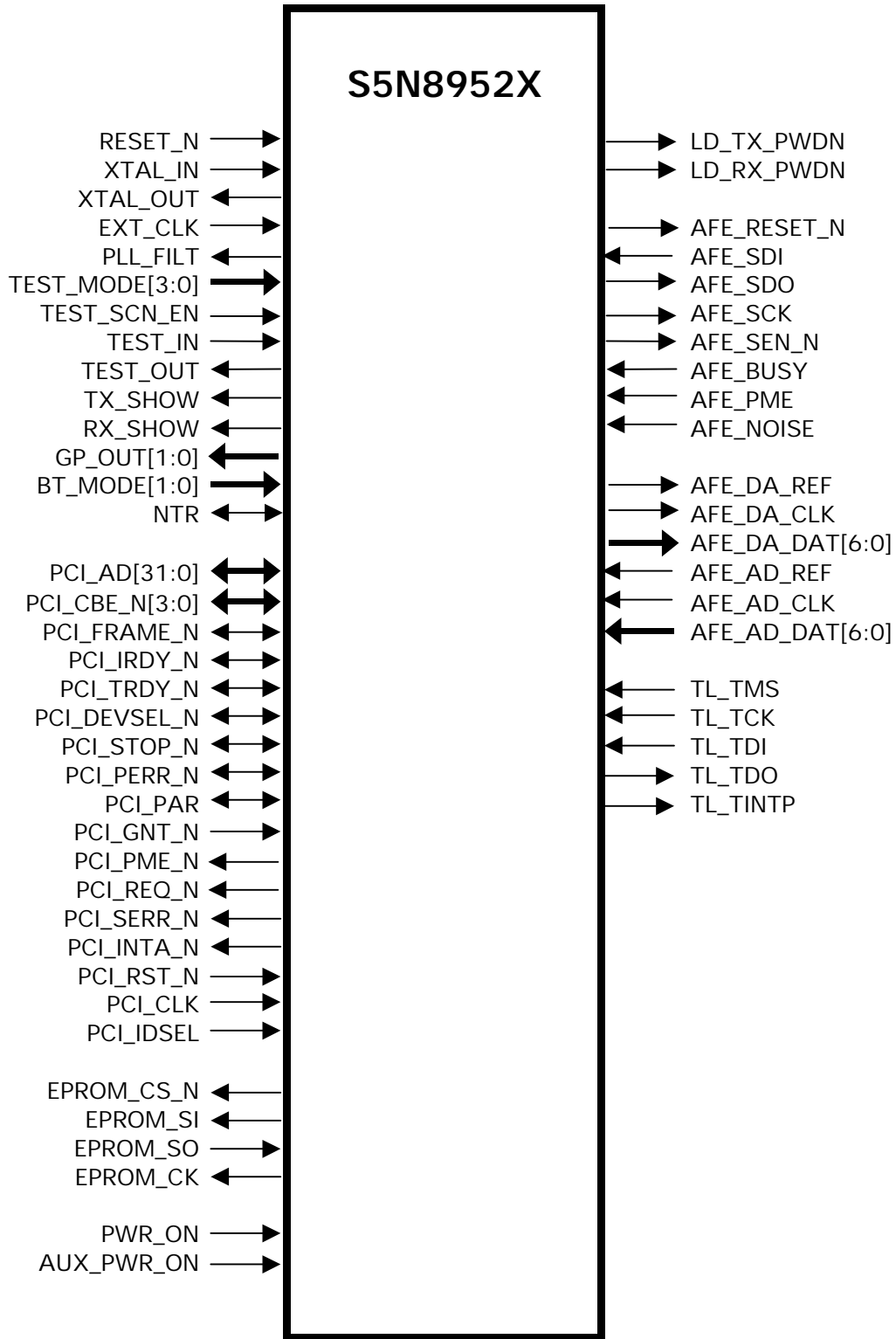

Figure 2: Logical Symbol Diagram of the S5N8952X

4. Pin Configuration

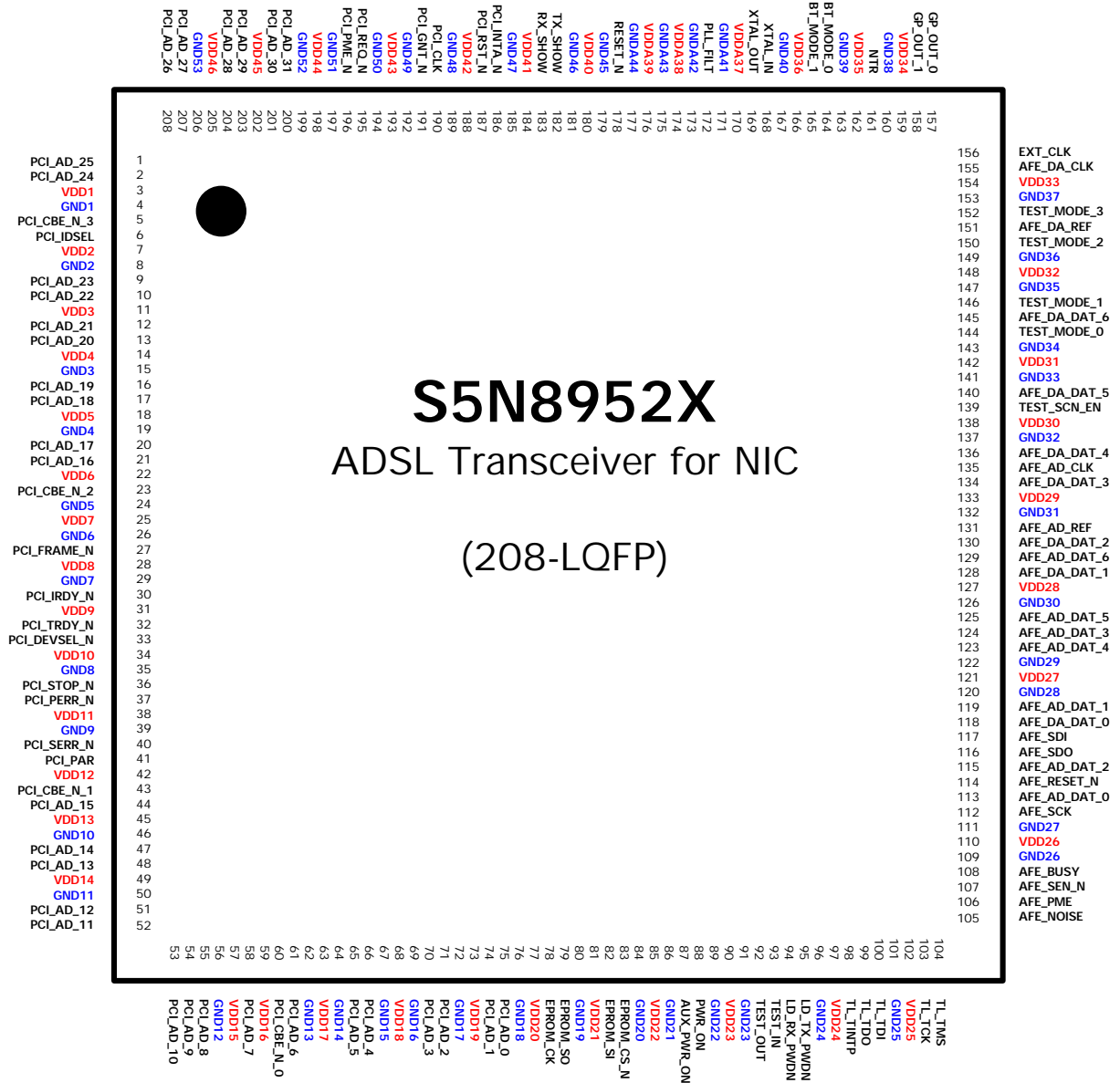

Figure 3: Pin Configuration of the S5N8952X

5. Pin Description

Table 1: Pin Description of the S5N8952X

No	Name	I/O	Description
178	RESET_N	I	System master reset (Active low)
168	XTAL_IN	I	System master clock (17.664MHz)
169	XTAL_OUT	O	
156	EXT_CLK	I	External clock for test (Float in normal mode)
172	PLL_FILT	O	PLL pump out (A 320pF capacitor between the pin and GNDA)
152	TEST_MODE_3	I	Chip test mode [0] Normal mode, [1-15] Test mode
150	TEST_MODE_2		
146	TEST_MODE_1		
144	TEST_MODE_0		
139	TEST_SCN_EN	I	Scan enable (Set to '0' in normal mode)
93	TEST_IN	I	Test input (Float in normal mode)
92	TEST_OUT	O	Test output (Float in normal mode)
182	TX_SHOW	O	Tx showtime indicator (Active high. Connect to LED)
183	RX_SHOW	O	Rx showtime indicator (Active high. Connect to LED)
158	GP_OUT_1	O	General purpose outputs (Float if not needed)
157	GP_OUT_0		
165	BT_MODE_1	I	Boot mode [0] Reset, [1] Boot from host [2] Boot from JTAG, [3] Self-booting
164	BT_MODE_0		
161	NTR	B	ATM network timing reference (8KHz. Float if not needed)
200	PCI_AD_31	B	PCI address data [31:0]
201	PCI_AD_30		
203	PCI_AD_29		
204	PCI_AD_28		
207	PCI_AD_27		
208	PCI_AD_26		
1	PCI_AD_25		
2	PCI_AD_24		
9	PCI_AD_23		
10	PCI_AD_22		
12	PCI_AD_21		
13	PCI_AD_20		
16	PCI_AD_19		
17	PCI_AD_18		
20	PCI_AD_17		
21	PCI_AD_16		
44	PCI_AD_15		
47	PCI_AD_14		
48	PCI_AD_13		

51	PCI_AD_12			
52	PCI_AD_11			
53	PCI_AD_10			
54	PCI_AD_9			
55	PCI_AD_8			
58	PCI_AD_7			
61	PCI_AD_6	B	PCI address data [31:0]	
65	PCI_AD_5			
66	PCI_AD_4			
70	PCI_AD_3			
71	PCI_AD_2			
74	PCI_AD_1			
75	PCI_AD_0			
5	PCI_CBE_N_3	B		PCI command byte enable [3:0]
23	PCI_CBE_N_2	B		
43	PCI_CBE_N_1	B		
60	PCI_CBE_N_0	B		
27	PCI_FRAME_N	B	PCI frame	
30	PCI_IRDY_N	B	PCI initiator ready	
32	PCI_TRDY_N	B	PCI target ready	
33	PCI_DEVSEL_N	B	PCI device select	
36	PCI_STOP_N	B	PCI stop	
37	PCI_PERR_N	B	PCI parity error	
41	PCI_PAR	B	PCI parity bit	
191	PCI_GNT_N	I	PCI grant	
40	PCI_SERR_N	OZ	PCI system error	
186	PCI_INTA_N	OZ	PCI interrupt A	
196	PCI_PME_N	OZ	PCI power management event	
195	PCI_REQ_N	OZ	PCI request	
187	PCI_RST_N	I	PCI reset	
190	PCI_CLK	I	PCI clock	
6	PCI_IDSEL	I	PCI initialization device select	
79	EPROM_SO	I	EPROM scan out	
82	EPROM_SI		EPROM scan in	
83	EPROM_CS_N	O	EPROM chip select	
78	EPROM_CK		EPROM clock	
87	AUX_PWR_ON	I	Aux power detected (Active high)	
88	PWR_ON	I	Main power detected (Active high)	
95	LD_TX_PWDN	O	Tx line driver power-down (Active high)	
94	LD_RX_PWDN	O	Rx line driver power-down (Active high)	
114	AFE_RESET_N	O	AFE reset (Active low)	
117	AFE_SDI	I	AFE serial interface data in	
116	AFE_SDO	O	AFE serial interface data out	
112	AFE_SCK	O	AFE serial interface clock	
107	AFE_SEN_N	O	AFE serial interface data enable (Active low)	
108	AFE_BUSY	I	AFE serial interface busy (Active high. Float if not	



			needed)
106	AFE_PME	I	AFE power management event (Active high. Float if not needed)
105	AFE_NOISE	I	Audible noise detection for power cutback (Active high. Float if not needed)
155	AFE_DA_CLK	O	DAC sample reference 1 (8.832MHz)
151	AFE_DA_REF	O	DAC sample reference 0 (4.416MHz)
145	AFE_DA_DAT_6	O	DAC data [6:0]
140	AFE_DA_DAT_5		
136	AFE_DA_DAT_4		
134	AFE_DA_DAT_3		
130	AFE_DA_DAT_2		
128	AFE_DA_DAT_1		
118	AFE_DA_DAT_0		
135	AFE_AD_CLK	I	ADC sample reference 1 (Float in normal mode)
131	AFE_AD_REF	I	ADC sample reference 0 (Float in normal mode)
129	AFE_AD_DAT_6	I	ADC Data [6:0]
125	AFE_AD_DAT_5		
123	AFE_AD_DAT_4		
124	AFE_AD_DAT_3		
115	AFE_AD_DAT_2		
119	AFE_AD_DAT_1		
113	AFE_AD_DAT_0		
104	TL_TMS	I	JTAG test mode select (Float in normal mode)
103	TL_TCK	I	JTAG test clock (Float in normal mode)
100	TL_TDI	I	JTAG test input data (Float in normal mode)
99	TL_TDO	OZ	JTAG test output data (Float in normal mode)
98	TL_TINTP	O	TJAM interrupt to host (Float in normal mode)
11	VDD3	P1	1.8V supply voltage
22	VDD6		
31	VDD9		
42	VDD12		
59	VDD16		
77	VDD20		
85	VDD22		
97	VDD24		
110	VDD26		
127	VDD28		
138	VDD30		
148	VDD32		
159	VDD34		
162	VDD35		
180	VDD40		
202	VDD45		
3	VDD1	P1	3.3V supply voltage
14	VDD4		
18	VDD5		



25	VDD7	P1	3.3V supply voltage
34	VDD10		
38	VDD11		
49	VDD14		
57	VDD15		
63	VDD17		
73	VDD19		
81	VDD21		
90	VDD23		
102	VDD25		
121	VDD27		
133	VDD29		
142	VDD31		
154	VDD33		
166	VDD36		
184	VDD41		
188	VDD42		
198	VDD44		
205	VDD46		
7	VDD2	P1	3.3V or 5V supply voltage for PCI only
28	VDD8		
45	VDD13		
68	VDD18		
193	VDD43		
4	GND1	P0	Ground
8	GND2		
15	GND3		
19	GND4		
24	GND5		
26	GND6		
29	GND7		
35	GND8		
39	GND9		
46	GND10		
50	GND11		
56	GND12		
62	GND13		
64	GND14		
67	GND15		
69	GND16		
72	GND17		
76	GND18		
80	GND19		
84	GND20		
86	GND21		
89	GND22		
91	GND23		
96	GND24		
101	GND25		



109	GND26	P0	Ground
111	GND27		
120	GND28		
122	GND29		
126	GND30		
132	GND31		
137	GND32		
141	GND33		
143	GND34		
147	GND35		
149	GND36		
153	GND37		
160	GND38		
163	GND39		
167	GND40		
179	GND45		
181	GND46		
185	GND47		
189	GND48		
192	GND49		
194	GND50		
197	GND51		
199	GND52		
206	GND53		
170	VDDA37	P1	1.8V analog supply voltage
174	VDDA38		
176	VDDA39		
171	GND41	P0	Analog ground
173	GND42		
175	GND43		
177	GND44		

I = Input
 O = Output
 OZ = Tri-state output
 B = Bi-direction
 P1 = Power
 P0 = Ground

6. Functional Description

The ADSL modem for customer premises consists of two main chips; ADSL transceiver chip (S5N8952) and analog front-end chip (S5N8951). The analog front-end provides an analog interface with line drivers and hybrid components for connecting to the PSTN. The ADSL Transceiver provides all the digital functions as depicted in Figure 4.

DMT inherently transmits an optimized time-variable spectrum. This spectrum is adjusted according to the desired data rate and the transmission characteristics (transfer function and noise spectrum) on each and every subchannel. For this, CO and CPE transmit 256 4kHz-wide tone downstream and upstream respectively to each other during initialization. They measure the quality of each of these received tones and then decide whether a tone has sufficient quality to be used for further transmission and, if so, how much data this tone should carry relative to the other tones that are used. They inform the bit loading informations to each other.

In FDM-based DMT (Discrete MultiTone) modulation, the frequency band, 0 to 1.104MHz, is divided into 256 equi-spaced subchannels with 4.3125KHz tone spacing. The frequency band, 26KHz (#6) to 134KHz (#31) is used for the upstream, and 142KHz (#33) to 1.1MHz (#255) for the downstream.

The S5N8952 provides PCI bus interface for NIC application and 14-bit AD/DA interface. SAR (Segmentation and Reassembly) and ATM TC (Transmission Convergence) are implemented for ATM cell handling and especially on-chip hardware SAR provides more processing power by reducing the PCI bus traffic than the software SAR. Reed-Solomon error correction with/without interleaver and Trellis coded modulation increase channel noise immunity. Time/frequency-domain equalizers, echo canceller, and digital filters, of which coefficients are adaptively updated according to the channel conditions, enhance the performance of data recovery.

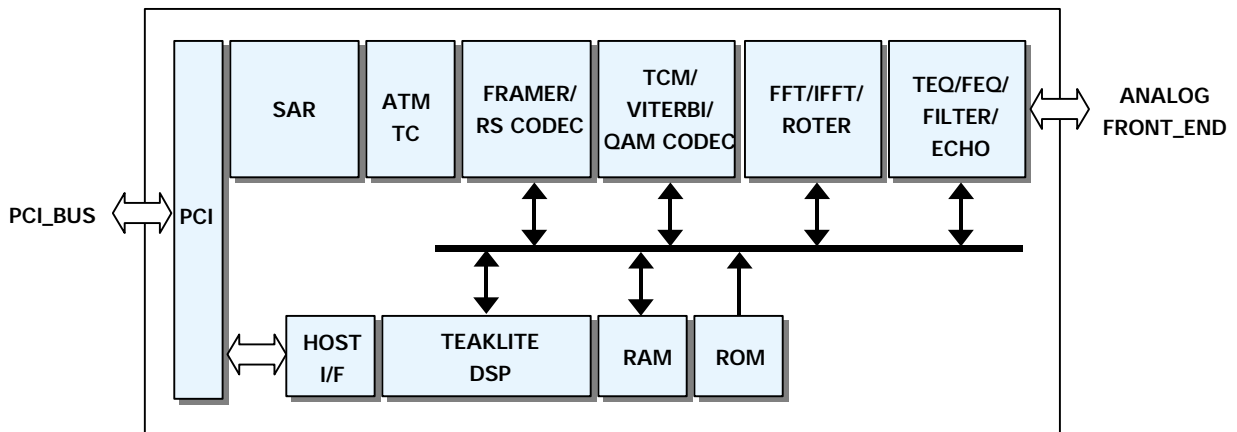
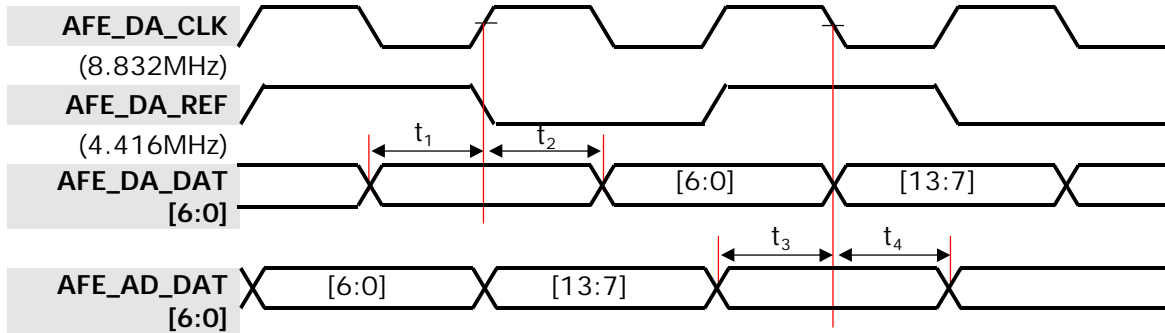

Figure 4: Functional Block Diagram of the S5N8952X

7. I/O Timing Description



Parameter	Description	Min	Max	Unit
t ₁	AFE_DA_DAT setup to AFE_DA_CLK ↑	15		ns
t ₂	AFE_DA_DAT hold after AFE_DA_CLK ↑	15		ns
t ₃	AFE_AD_DAT setup to AFE_DA_CLK ↓	30		ns
t ₄	AFE_AD_DAT hold after AFE_DA_CLK ↓	1		ns

Figure 5: AFE Data I/F Timing Diagram

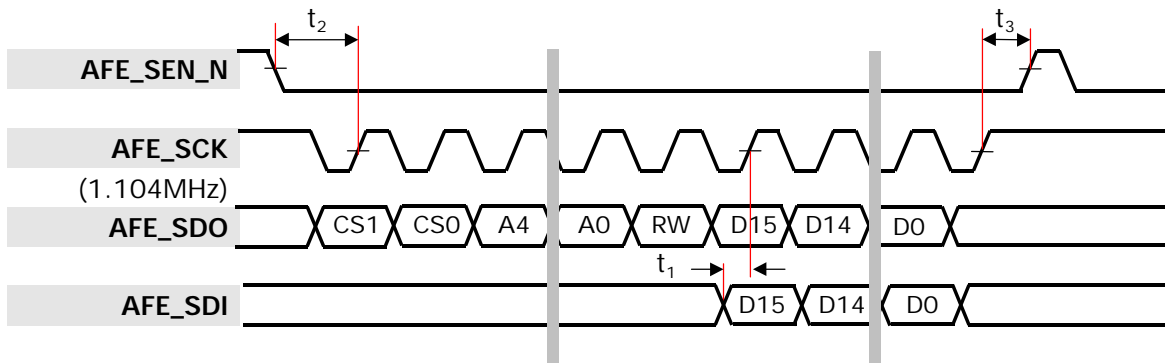

Parameter	Description	Min	Max	Unit
t ₁	AFE_SDI setup to AFE_SCK↑	30		ns
t ₂	AFE_SEN_N ↓ before AFE_SCK ↑	30		ns
t ₃	AFE_SEN_N ↑ from AFE_SCK ↑	15		ns

Figure 6: AFE Control I/F Timing Diagram

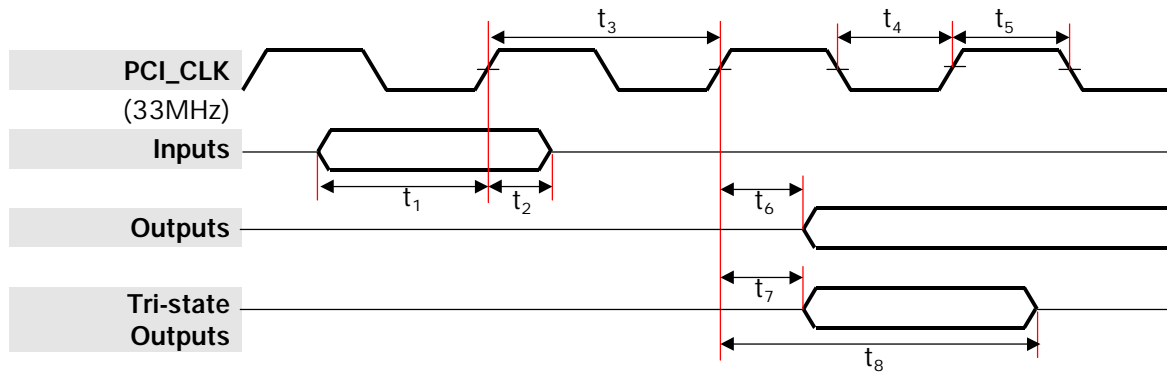

Parameter	Description	Min	Max	Unit
t_1	Input setup to PCI_CLK \uparrow	3		ns
t_2	Input hold after PCI_CLK \uparrow	0		ns
t_3	PCI_CLK period	30		ns
t_4	PCI_CLK low time	6		ns
t_5	PCI_CLK high time	6		ns
t_6	PCI_CLK \uparrow to signal valid delay	1	6	ns
t_7	Float to active delay	1		ns
t_8	Active to float delay		14	ns

Figure 7: PCI I/F Timing Diagram

8. Electrical Characteristics

Table 2: Absolute Maximum Ratings

Symbol	Parameter	Rating	Unit
I_{LATCH}	Latch-up Current	± 200	mA
T_{STG}	Storage Temperature	-65 to 150	$^{\circ}\text{C}$

Table 3: Recommended Operating Conditions

Symbol	Parameter	Rating		Unit
V_{DD}	DC Supply Voltage	1.8V I/O	1.65 to 1.95	V
		3.3V I/O	3.0 to 3.6	
		5V-tolerant I/O (3.3V Interface)	3.0 to 3.6	
	Analog Core DC Supply Voltage	1.8V Core	1.8 \pm 5%	
T_A	Operating Temperature (Ambient)	Commercial	0 to 70	$^{\circ}\text{C}$

Table 4: Power Dissipation

Symbol	Parameter	Min	Typ	Max	Unit
P_D	Power Dissipation	-	0.3	-	W

Table 5: DC Characteristics

Symbol	Parameters	Min	Typ	Max	Unit
V_{IH}	Input High Voltage	2.0	-	-	V
V_{IL}	Input Low Voltage	-	-	0.8	
V_{OH}	Output High Voltage	2.4	-	-	
V_{OL}	Output Low Voltage	-	-	0.4	
V_T	Switching Threshold	-	1.4	-	
V_{T+}	Schmitt Trigger, Positive-going Threshold	-	-	2.0	
V_{T-}	Schmitt Trigger, Negative-going Threshold	0.8	-	-	
I_{IH}	Input High Current ($V_{IN} = V_{DD}$)	-10	-	10	μA
		10*	33*	60*	
I_{IL}	Input Low Current ($V_{IN} = V_{SS}$)	-10	-	10	
		-60*	-33*	-10*	
I_{OZ}	Tri-state Output Leakage Current	-10	-	10	
I_{DD}	Quiescent Supply Current	-	-	100	
C_{IN}	Input Capacitance	-	-	4	
C_{OUT}	Output Capacitance	-	-	4	

NOTES:

* - input buffer with pull-up($V_{IN} = V_{SS}$) or pull-down($V_{IN} = V_{DD}$).

9. Package Description

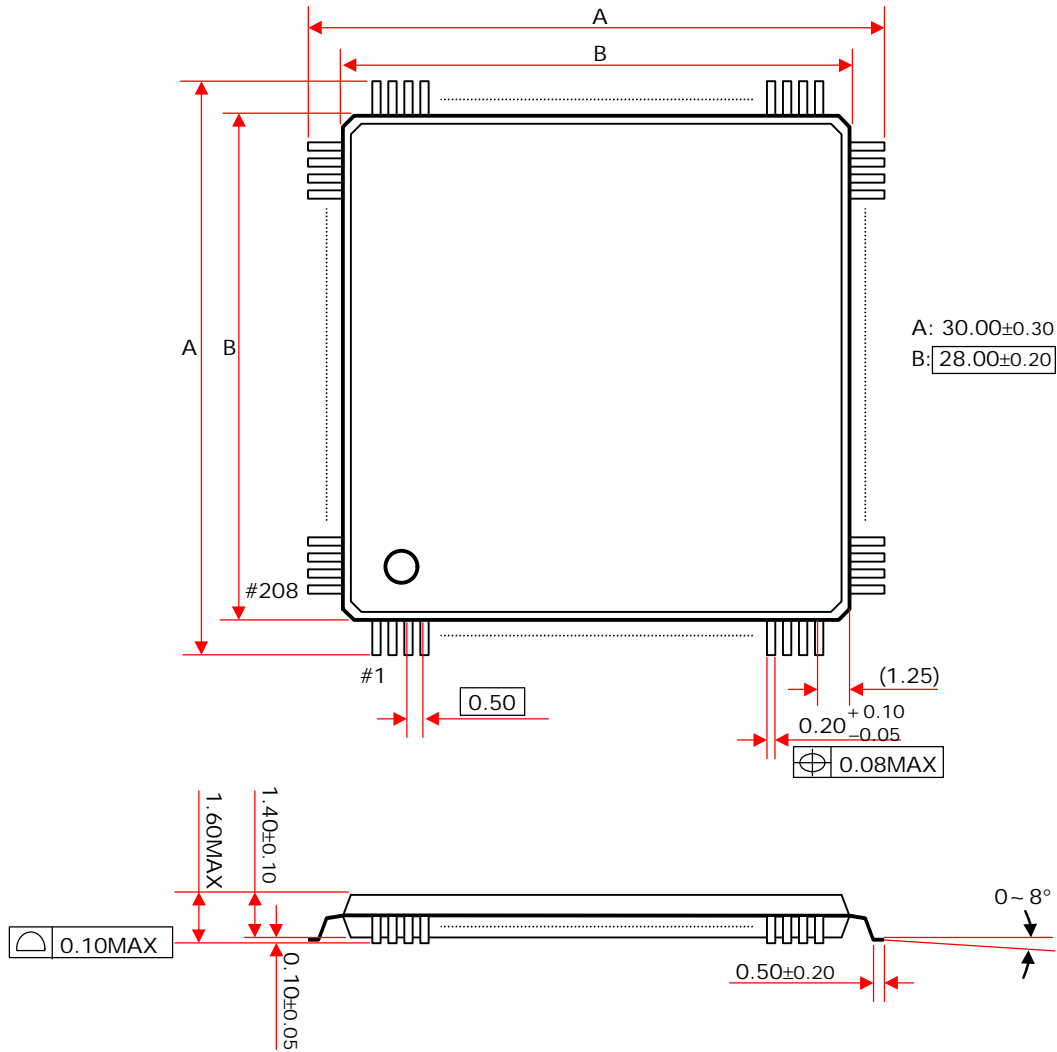

Figure 8: 208-LQFP Package Diagram



Revision History

Revision No.	Date	Description
1.0	2000-09-15	First released.
1.1	2000-09-20	Pin configuration changed.
2.0	2000-11-15	T1.413 issue-2 added. PCI version upgraded from 2.1 to 2.2

IMPORTANT NOTICE

The information furnished by Samsung Electronics in this document is believed to be accurate and reliable. However, no responsibility is assumed by Samsung Electronics for its use, nor for any infringements of patents or other rights of third parties resulting from its use. No license is granted under any patents or patent rights of Samsung Electronics. Samsung Electronics reserves the right to make changes to its products or to discontinue any semiconductor product or service without notice, and advises its customers to obtain the latest version of relevant information to verify, before placing orders, that the information being relied on is current and complete.

For More Information

Tel: (82)-(31)-209-8301, Fax: (82)-(31)-209-8309

E-mail: kimil@sec.samsung.com

<http://www.intl.samsungsemi.com>