

INTRODUCTION

The S5T8803A is designed to select 10 channels of a cordless phone, whose frequency band is 46/49MHz. It has a reference frequency generator, programmable divider for Transmit and Receive section, and phase detector.

FEATURES

- Able to select 10 Channels: S5T8803A (both transmit/receive)
- Include oscillation circuit with external x-tal (10.24MHz)
- 5KHz output for guard tone
- Unlock detector (phase difference more than 6.25us)
- Standby function for power saving

16-DIP-300A

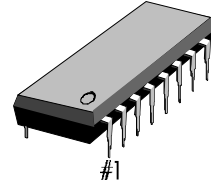

16-SOP-225

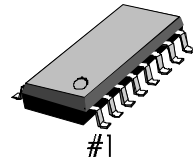

ORDERING INFORMATION

Device	Package	Operating Temperature
S5T8803A01-D0B0	16-DIP-300A	-30°C to +75°C
S5T8803A01-S0B0	16-SOP-225	

BLOCK DIAGRAM

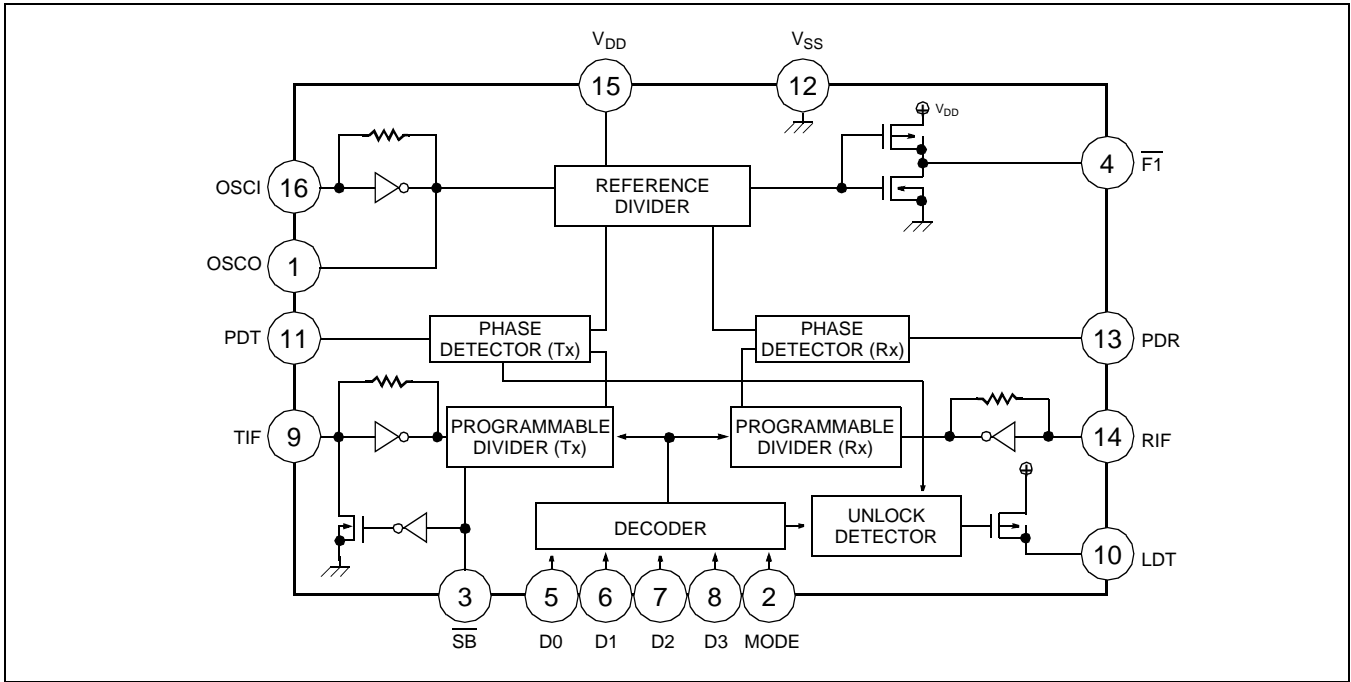

PIN CONFIGURATION

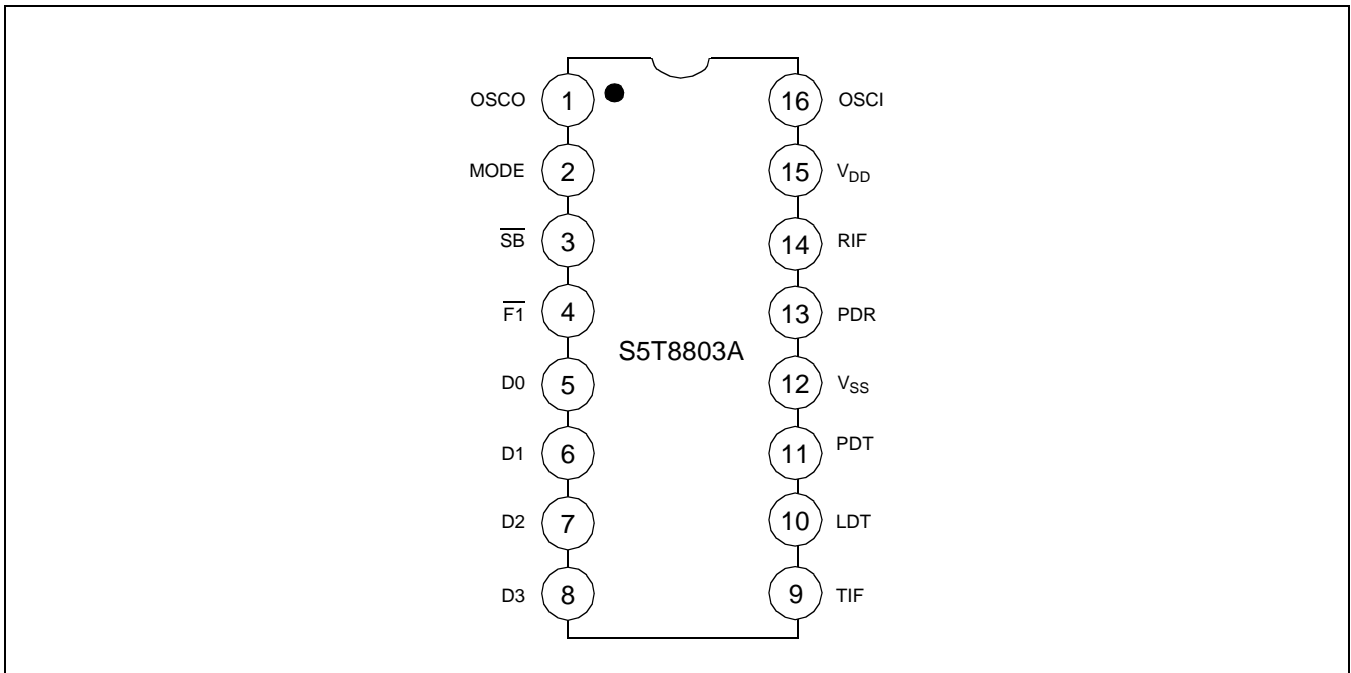

PIN DESCRIPTION

Pin No	Symbol	Description
1	OSCO	This output generates the reference frequency when it is connected to Pin 16 with the external OSC, whose frequency is 10.24MHz.
2	MODE	Base/Remote Unit Selection Pin. “High”: Base Unit “Low” : Remote Unit
3	SB	Standby pin. This input controls Tx PLL for reducing the power dissipation “High”: Normal operation “Low”: Standby
4	F1	5KHz output
5, 6 7, 8	D0, D1 D2, D3	Channel selection pins The Combinations of these inputs select one channel among the 10 channels
9	TIF	Input to programmable divider of Tx. AC coupling with VCO In case of a larger signal, It needs DC–coupling. Minimum input voltage is 0.1 Vrms
10	LDT	Unlocked signal out pin (see output characteristics)
11	PDT	Phase detector output for Tx. PDT detects the phase error from Tx PLL and its output is connected to the external low pass filter
12	VSS	This pin is the negative supply of the IC. It is usually grounded
13	PDR	Phase detector output for Rx. PDR detects the phase error from Rx PLL and its output is connected to the external low pass filter
14	RIF	Input of programmable divider for Rx. AC coupling with VCO In case of a larger signal (standard CMOS logic), it needs DC coupling. Minimum input voltage is 0.1Vrms
15	V _{DD}	This pin is the positive supply of the IC Its reference is V _{SS} , and normally + 3.0V ~ + 5.5V more positive than V _{SS}
16	OSCI	X-TAL OSC connection pin This input generates the reference frequency when it is connected to pin 1 with the external OSC

ABSOLUTE MAXIMUM RATINGS

Characteristic	Symbol	Value	Unit
Supply voltage	V _{DD}	-0.5 ~ +6.0	V
Input Voltage	V _I	-0.3 ~ V _{DD} + 0.5	V
Power Dissipation	P _D	350	mW
Operating Temperature	T _{OPR}	-30 ~ + 75	°C
Storage Temperature	T _{STG}	-40 ~ + 125	°C

ELECTRICAL CHARACTERISTICS

(Ta = 25°C, V_{DD} = 5 V, unless otherwise specified)

Characteristic	Symbol	Test Conditions	Min.	Typ.	Max.	Unit
Supply Voltage	V _{DD}	–	3	–	5.5	V
Input Voltage	V _{IH1}	D0 - D3, \overline{SB}	0.7 V _{DD}	–	V _{DD}	V
	V _{IL1}	D0 - D3, \overline{SB}	–	–	0.3V _{DD}	V
	V _{IH2}	MODE	0.9 V _{DD}	–	V _{DD}	V
	V _{IL2}	MODE	–	–	0.1V _{DD}	V
Input Frequency	f _{I1}	V _{TIF} = 0.15Vrms	10	–	52	MHz
	f _{I2}	V _{RIF} = 0.15Vrms	30	–	42	MHz
	f _{I3}	OSC _{IN} = 0.3Vrms	5	10.24	11	MHz
Input Amplitude	V _{I(AMP)1}	f _{TIF} = 52MHz	0.1	–	0.3V _{DD}	Vrms
	V _{I(AMP)2}	f _{RIF} = 42MHz	0.1	–	0.3V _{DD}	Vrms
	V _{I(AMP)3}	OSC _{IN} = 11MHz	0.3	–	0.3V _{DD}	Vrms
Input Current	I _{IH}	V _{IN} = V _{DD}	–	–	40	μA
	I _{IL}	V _{IN} = V _{SS}	–	–	40	μA
Output Voltage	V _{OH1}	PDT, RDR: I _O = 0.5mA	V _{DD} -1.0	–	–	V
	V _{OL1}	PDT, RDR : I _O = 0.5mA	–	–	1.0	V
	V _{OH2}	LDT: I _O = 1mA	V _{DD} -1.0	–	–	V
	V _{OL2}	F1: I _O = 1mA	–	–	1.0	V
Output OFF Leakage Current	I _{LKG1}	PDT, PDR : V _O = V _{DD} /V _{SS}	–	0.01	1.0	μA
	I _{LKG2}	LDT: V _O = V _{SS}	–	–	5.0	μA
Standby Current	I _{SB1}	V _{DD} = 3V (Note 2)	–	1.0	2.0	mA
	I _{SB2}	V _{DD} = 3V (Note 2)	3.5	4.0	–	mA
Operating Current	I _{DD1}	V _{DD} = 3V (Note 1)	–	2.0	3.0	mA
	I _{DD2}	V _{DD} = 5V (Note 1)	–	6.0	7.0	mA

NOTES:

- OSC IN: 10.24MHz X-tal Connection
 TIF: 27MHz 150 mVrms
 RIF: 42MHz 150 mVrms
 MODE: V_{DD}, SB = V_{DD}, others are opened
- OSC IN: 10.24MHz X-tal Connection
 TIF: 27MHz 150mVrms
 RIF: 42MHz 150mVrms
 MODE: V_{DD}, SB = V_{SS}, others are opened
 Capacitor more than 2000pF should be connected between V_{DD} & V_{SS}

OUTPUT CHARACTERISTICS

LOCK

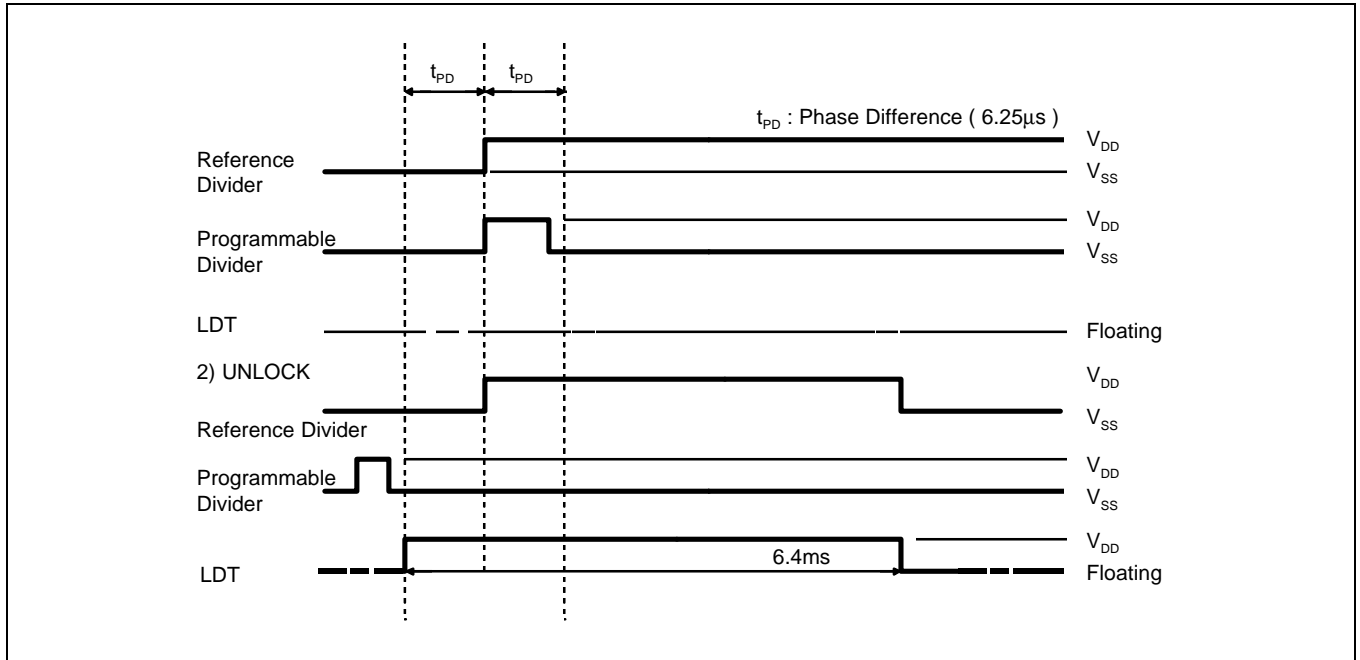

Figure 1.

Channel & Frequency table to Base/Remote Input Data for S5T8803A (10-CH)

BASE (MODE = 1)

INPUT					Rx ($f_{REF} = 5\text{kHz}$)			Tx ($f_{REF} = 5\text{kHz}$)		
D0	D1	D2	D3	CH	$f_{RX}(\text{MHz})$	$f_{VCO}(\text{MHz})$	N	$f_{TX}(\text{MHz})$	$f_{VCO}(\text{MHz})$	N
1	0	0	0	1	49.670	38.975	7795	46.610	46.610	9322
0	1	0	0	2	49.845	39.150	7830	46.630	46.630	9326
1	1	0	0	3	49.860	39.165	7833	46.670	46.670	9334
0	0	1	0	4	49.770	39.075	7815	46.710	46.710	9342
1	0	1	0	5	49.875	39.180	7836	46.730	46.730	9346
0	1	1	0	6	49.830	39.135	7827	46.770	46.770	9354
1	1	1	0	7	49.890	39.195	7839	46.830	46.830	9366
0	0	0	1	8	49.930	39.235	7847	46.870	46.870	9374
1	0	0	1	9	49.990	39.295	7859	46.930	46.930	9386
0	1	0	1	10	49.970	39.275	7855	46.970	46.970	9394
1	1	0	1	10	49.970	39.275	7855	46.970	46.970	9394
0	0	1	1	10	49.970	39.275	7855	46.970	46.970	9394
1	0	1	1	10	49.970	39.275	7855	46.970	46.970	9394
0	1	1	1	10	49.970	39.275	7855	46.970	46.970	9394
1	1	1	1	10	49.970	39.275	7855	46.970	46.970	9394
0	0	0	0	10	49.970	39.275	7855	46.970	46.970	9394

REMOTE (MODE = 0)

INPUT					Rx ($f_{REF} = 5\text{kHz}$)			Tx ($f_{REF} = 5\text{kHz}$)		
D0	D1	D2	D3	CH	$f_{RX}(\text{MHz})$	$f_{VCO}(\text{MHz})$	N	$f_{RX}(\text{MHz})$	$f_{VCO}(\text{MHz})$	N
1	0	0	0	1	46.610	35.915	7183	49.670	49.670	9934
0	1	0	0	2	46.630	35.935	7187	49.845	49.845	9969
1	1	0	0	3	46.670	35.975	7195	49.860	49.860	9972
0	0	1	0	4	46.710	36.015	7203	49.770	49.770	9954
1	0	1	0	5	46.730	36.035	7207	49.875	49.875	9975
0	1	1	0	6	46.770	36.075	7215	49.830	49.830	9966
1	1	1	0	7	46.830	36.135	7227	49.890	49.890	9978
0	0	0	1	8	46.870	36.175	7235	49.930	49.930	9986
1	0	0	1	9	46.930	36.235	7247	49.990	49.990	9998
0	1	0	1	10	46.970	36.275	7255	49.970	49.970	9994
1	1	0	1	10	46.970	36.275	7555	49.970	49.970	9994
0	0	1	1	10	46.970	36.275	7255	49.970	49.970	9994
1	0	1	1	10	46.970	36.275	7255	49.970	49.970	9994
0	1	1	1	10	46.970	36.275	7255	49.970	49.970	9994
1	1	1	1	10	46.970	36.275	7255	49.970	49.970	9994
0	0	0	0	10	46.970	36.275	7255	49.970	49.970	9994

APPLICATION CIRCUIT

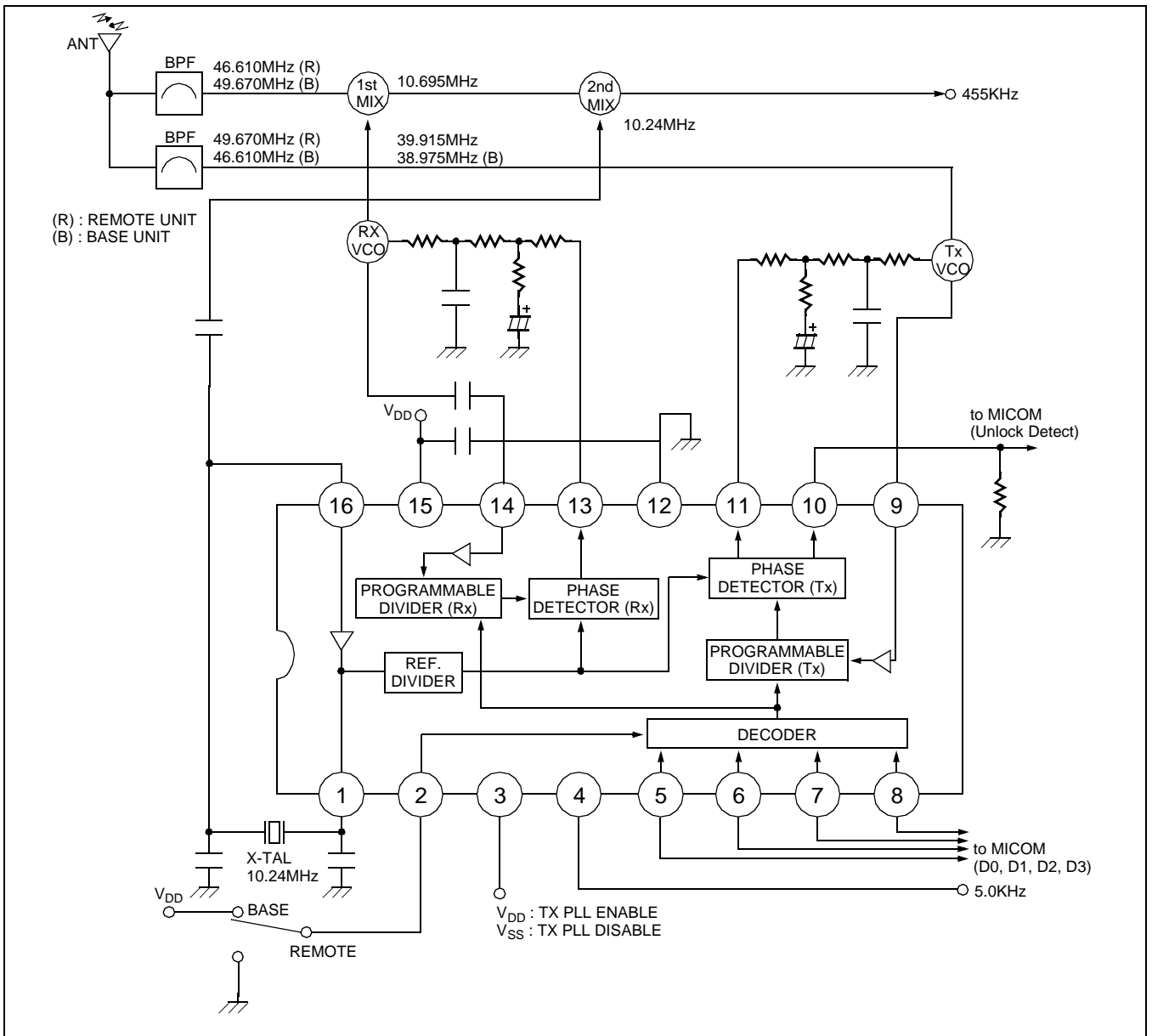

NOTES