



S5U13781R00C10M

User Manual

Document Number: X94A-G-008-01

Status: Revision 0.93

Issue Date: 2012/09/14

Evaluation board/kit and Development tool important notice

1. This evaluation board/kit or development tool is designed for use for engineering evaluation, demonstration, or development purposes only. Do not use it for other purpose. It is not intended to meet the requirement of design for finished product.
2. This evaluation board/kit or development tool is intended for use by an electronics engineer, and it is not a consumer product. The user should use these goods properly and safely. Seiko Epson does not assume any responsibility and liability of any kind of damage and/or fire caused by usage of it. The user should cease to use it when any abnormal issue occurs, even during proper and safe use.
3. The parts used for this evaluation board/kit or development tool may change without notice.

NOTICE

No part of this material may be reproduced or duplicated in any form or by any means without the written permission of Seiko Epson. Seiko Epson reserves the right to make changes to this material without notice. Seiko Epson does not assume any liability of any kind arising out of any inaccuracies contained in this material or due to its application or use in any product or circuit and, further, there is no representation that this material is applicable to products requiring high level reliability, such as, medical products. Moreover, no license to any intellectual property rights is granted by implication or otherwise, and there is no representation or warranty that anything made in accordance with this material will be free from any patent or copyright infringement of a third party. This material or portions thereof may contain technology or the subject relating to strategic products under the control of the Foreign Exchange and Foreign Trade Law of Japan and may require an export license from the Ministry of Economy, Trade and Industry or other approval from another government agency.

All brands or product names mentioned herein are trademarks and/or registered trademarks of their respective companies.

©SEIKO EPSON CORPORATION 2012, All rights reserved.

Table of Contents

1	Introduction.....	4
2	LCD Module Options and Parts Lists	6
3	Connecting the Boards.....	8
4	StellarisWare Drivers and Demo Software	11
4.1	Requirements.....	11
4.1.1	Hardware Requirements	11
4.1.2	Software Requirements	11
4.2	Software Installation	11
4.3	Software Description	13
4.3.1	Driver Software.....	13
4.3.2	Demonstration Software	14
4.4	Software Modification	14
4.5	Software License.....	14
5	Stellaris LM4F120 Launchpad Connections.....	15
6	Pinout for 40-Pin LCD Interface	17
7	Pinout for 54-Pin LCD Interface	19
8	S5U13781M00C100 Schematics	23
9	S5U13781M00C100 Board Layout.....	27
10	References	31
11	Change Record.....	32

1 Introduction

The S5U13781R00C10M is the **S1D13781 BoosterPack LCDC Development Package**. It is a BoosterPack board set for TI's Stellaris LM4F120 Launchpad for evaluating and developing embedded LCD display applications using the Epson S1D13781 LCD Controller IC.

The S5U13781R00C10M consists of the following two items:

- S5U13781R00C100 Reference Board Set
- S5U13781M00C100 Signal Adapter Board Set

Figure 1 shows a picture of the S5U13781R00C100 Reference Board Set.

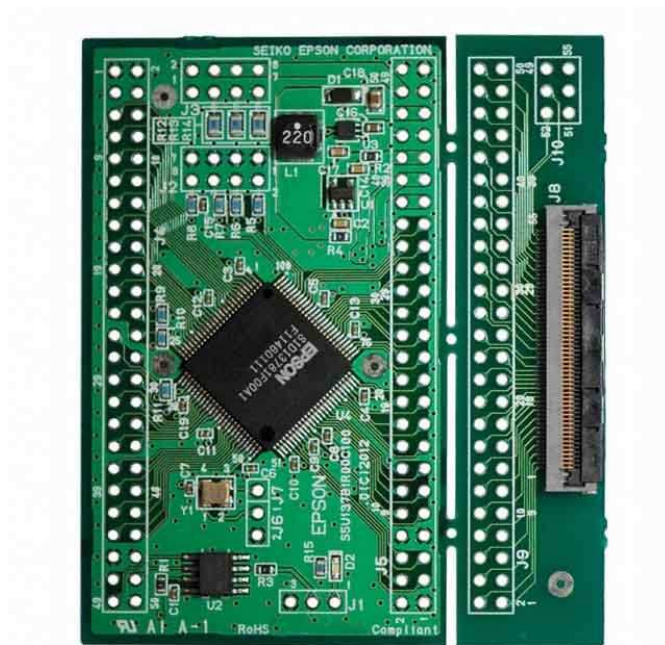

Figure 1 – S5U13781R00C100 Reference Board Set

The S5U13781R00C100 Reference Board Set consists of two break-off sub-boards:

- Main board which has the S1D13781 LCD Controller, 2Mbytes of Serial Flash, DC/DC converter for LED backlight, 2x25 connector for Host interface (J4), and 2x25 connector for LCD interface (J5).
- LCD interface board which has a 54-pin FPC (flexible printed circuit) connector (J8) to connect to LCD module and 0.1"-pitch 2x25+2x6 connectors (J9 and J10).

For more information about the S5U13781R00C100, please refer to the "S5U13781R00C100 Reference Board User Manual", document number X94A-G-004-01

Figure 2 shows a picture of the S5U13781M00C100 Signal Adapter Board Set.

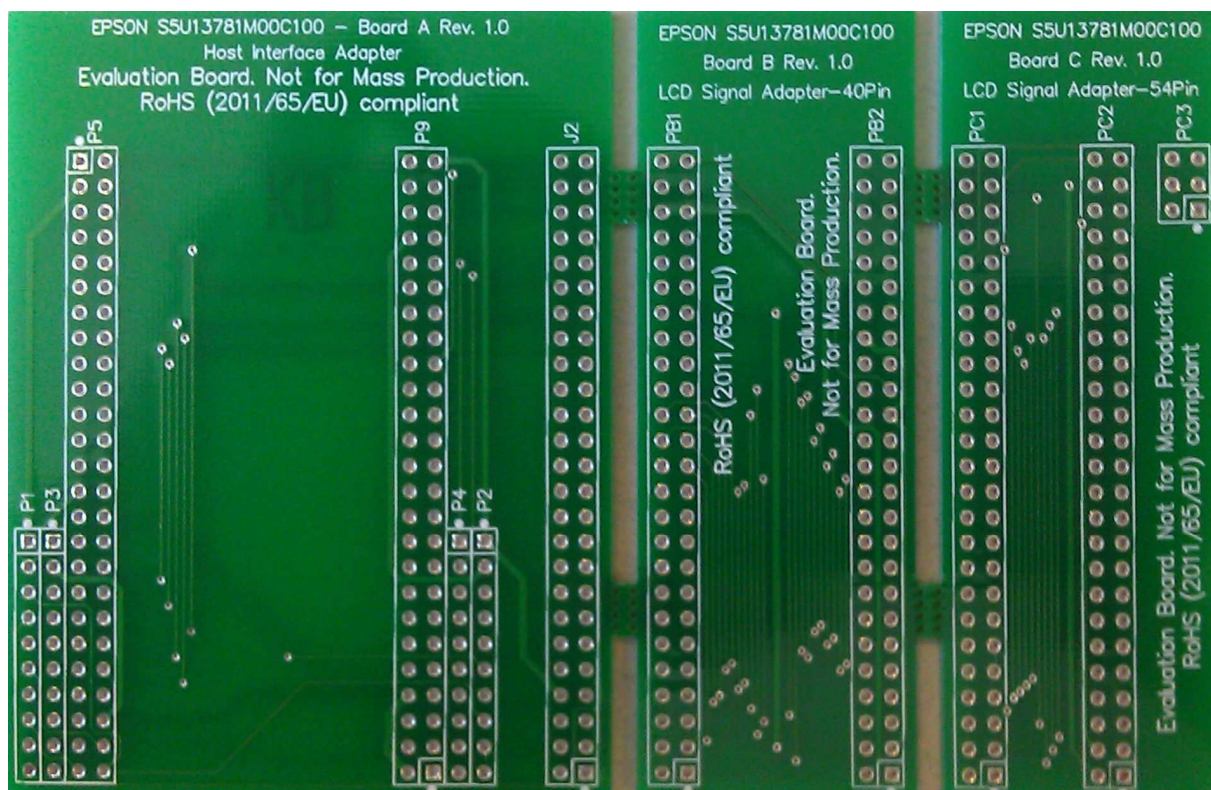

Figure 2 – S5U13781M00C100 Signal Adapter Board Set

The S5U13781M00C100 Signal Adapter Board Set is a supplement to the S5U13781R00C100 Reference Board Set and it consists of three break-off sub-boards (schematics and layout are in Sections 8 and 9):

- “Board A – Host Interface Adapter” is used to adapt the S5U13781R00C100 Main Board’s Host Interface signals (P5) to the Stellaris LM4F120 Launchpad BoosterPack connectors (P1 to P4), and it also routes the S5U13781R00C100 Main Boards’ LCD Interface signals (P9) to a connector (J2) for connecting to either “Board B – LCD Signal Adapter – 40Pin” or “Board C – LCD Signal Adapter – 54Pin”.
- “Board B – LCD Signal Adapter – 40Pin” provides signal routing for connecting to an LCD module with a 40-pin FPC (4.3” WQVGA). One side (PB1) connects to J2 of Board A and the other side (PB2) connects to J9 of the S5U13781R00C100 LCD interface board.
- “Board C – LCD Signal Adapter – 54Pin” provides signal routing for connecting to an LCD module with a 54-pin FPC (3.5” QVGA). One side (PC1) connects to J2 of Board A and the other side (PC2+PC3) connects to J9+J10 of the S5U13781R00C100 LCD interface board.

This user manual is updated as appropriate. Please check the Seiko Epson Website at http://www.epson.jp/device/semicon_e/product/lcd_controllers/index.htm for the latest revision of this document before beginning any development.

We appreciate your comments on our documentation. Please contact us via email at documentation@erd.epson.com.

2 LCD Module Options and Parts Lists

The S5U13781R00C10M development package can interface to two types of LCD modules. One type of LCD module has a 40-pin FPC interface (4.3" WQVGA display) and the other type has a 54-pin FPC interface (3.5" QVGA).

The boards in the S5U13781R00C10M package do not come with any header/receptacle connectors installed. These connectors will have to be purchased separately and soldered to the boards by the end-user.

The following table shows the two LCD module options and their parts list (with Mouser part numbers):

	<u>40-Pin Interface</u>	<u>54-Pin Interface</u>	<u>Manufacturer Part Number</u>
S5U13781R00C10M	1	1	Epson S5U13781R00C10M
2x25, 0.1"-pitch header	4	4	3M 961250-6404-AR
2x25, 0.1"-pitch receptacle	4	4	3M 929975-01-25-RK
2x10, 0.1"-pitch receptacle	2	2	3M 929975-01-10-RK
2x3, 0.1"-pitch header	-	1	3M 929836-01-03-RK
2x3, 0.1"-pitch receptacle	-	1	3M 929975-01-03-RK
54-Pin, 3.5", QVGA LCD	-	1	Newhaven Display NHD-3.5-320240MF-ATXL#-1 or <i>Hantronix HDA351-LV</i> <i>Evervision VGG322425-6UFLWA</i> or <i>Topway LMT035KDH03</i> or <i>Tianma TM035KDH03</i> or <i>All Shore ASI-T-350EA3NN/D</i> or <i>Powertip PH320240T-006-I-Q</i> or <i>Ampire AM320240L2TMQW-TB0H</i> or <i>Logic Tech. LTTD320240035-LIRT</i> or <i>US Micro USMP-TT035Q-01D</i> or <i>Tech Toys LVC75Z779V2S</i> or <i>Microtips MTF-TQ35SP741-AV</i>
40-Pin, 4.3", WQVGA LCD	1	-	Newhaven Display NHD-4.3-480272EF-ATXL#(-T) or <i>All Shore ASI-T-430FA6NT/H</i> or <i>AZ Displays ATM0430D5(-T)</i> or <i>Logic Tech. LTTD480272043-L1</i> or <i>Tianma TM043NBH02</i>

NOTE: The Stellaris LM4F120 Launchpad board is not included in the parts list and will have to be purchased separately if the end-user does not already have one.

3 Connecting the Boards

Figure 3 shows the board connections diagram (side view) for the S5U13781R00C10M BoosterPack LCDC Development Package.

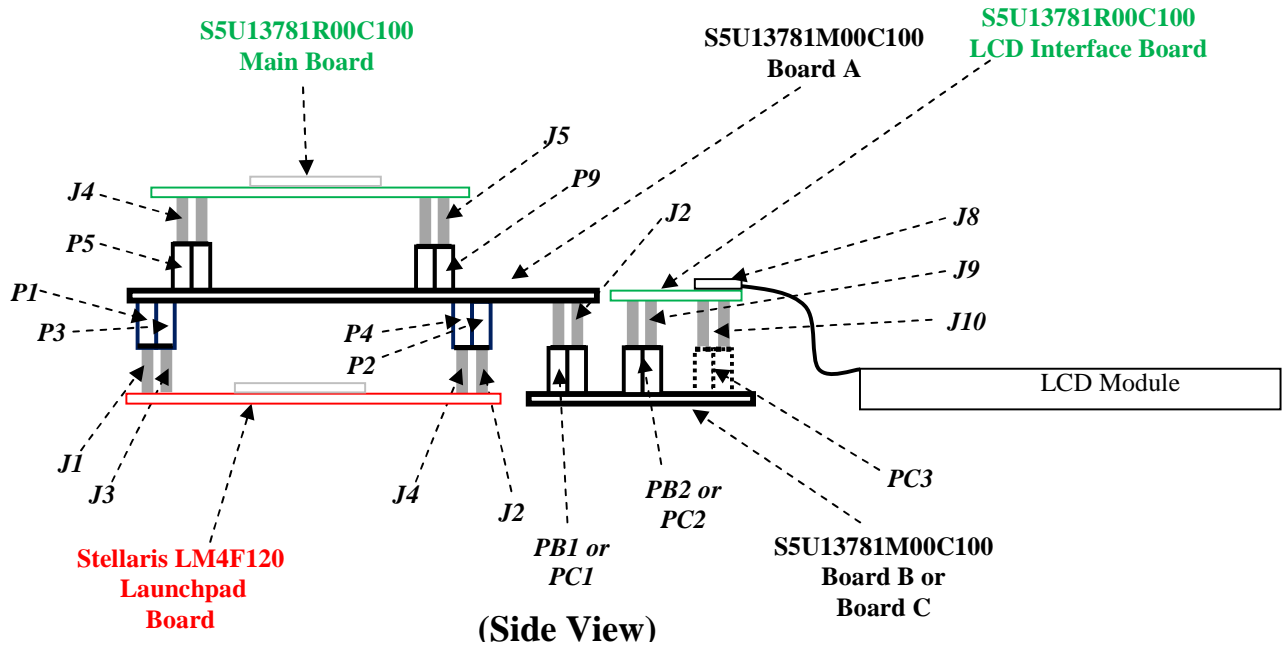

Figure 3 – Board Connections Diagram

The Stellaris LM4F120 Launchpad board has 2x10 headers on the top side for J1/J3 and J2/J4.

J8 of the S5U13781R00C100 LCD Interface Board is an FPC connector with bottom side contacts. The FPC of the LCD module should be inserted into J8 with contacts facing down and pin 1 lined up with the pin 1 edge of J8 (see Figure 4).

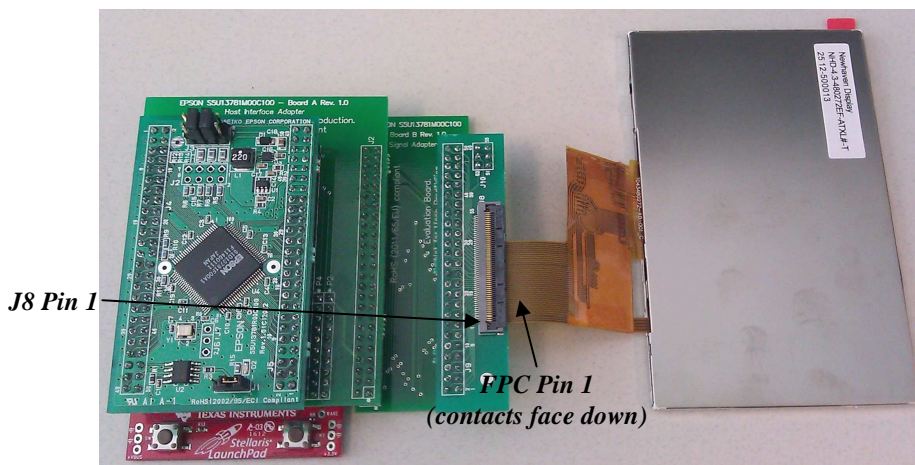

Figure 4 – J8 FPC Connection Example for 40-Pin LCD Module

STEPS FOR ASSEMBLING S5U13781R00C10M DEVELOPMENT PACKAGE

Modification to Stellaris LM4F120 Launchpad Board

- 1) On the Stellaris LM4F120 Launchpad board, remove (de-solder) resistors R9 and R10. This disconnects the short-circuits between GPIO ports PB6/PD0 and PB7/PD1.

Soldering of Header and Receptacles

- 2) On the S5U13781R00C100 Main Board, connect pins 3 and 4 of J3 (solder a wire across the two pins or solder a header with shunt jumper) to set the current of the backlight LED driver to 20mA. The Newhaven 3.5" display is rated at 20mA typical and the Newhaven 4.3" display is rated at 32mA typical. (Current drive can be increased in steps of 20mA by shorting pins 5-6 and pins 7-8 of J3.)
- 3) On the S5U13781R00C100 Main Board, connect pins 1 and 2 of J1 (solder a wire across the two pins or solder a header with shunt jumper) to connect power for the Serial Flash.
- 4) On the bottom side of the **S5U13781R00C100 Main Board**, install and solder 2x25 headers for J4 and J5.
- 5) On the top side of the **S5U13781M00C100 Board A**, install and solder 2x25 receptacles for P5 and P9.
- 6) On the bottom side of the **S5U13781M00C100 Board A**, install and solder 2x10 receptacles for P1+P3 and P2+P4. (Note that P1 and P3 together make up one 2x10 receptacle and P2 and P4 together make up the other 2x10 receptacle.)
- 7) On the bottom side of the **S5U13781M00C100 Board A**, install and solder a 2x25 header for J2.
- 8) For a 40-pin (4.3", WQVGA) LCD module, use **S5U13781M00C100 Board B** and install (on the top side) 2x25 receptacles for PB1 and PB2. For a 54-pin (3.5", QVGA) LCD module, use **S5U13781M00C100 Board C** and install (on the top side) 2x25 receptacles for PC1 and PC2 as well as a 2x3 receptacle for PC3.
- 9) On the bottom side of the **S5U13781R00C100 LCD Interface Board**, install and solder a 2x25 header for J9. If using a 54-pin LCD module, a 2x3 header for J10 should also be installed and soldered on the bottom side of the **S5U13781R00C100 LCD Interface Board**.

Assembly of Boards

- 10) Plug the bottom 2x10 receptacles of **S5U13781M00C100 Board A** to the Stellaris LM4F120 Launchpad 2x10 headers. Make sure the pin 1s of P1-P4 of **S5U13781M00C100 Board A** line up with pin1s of J1-J4 of the Stellaris LM4F120 Launchpad.
- 11) Plug the bottom headers (J4, J5) of **S5U13781R00C100 Main Board** to the top side receptacles (P5, P9) of **S5U13781M00C100 Board A**. Make sure the pin 1s of J4 and J5 of the **S5U13781R00C100 Main Board** line up with the pin1s of P5 and P9 of **S5U13781M00C100 Board A**.
- 12) Plug the 2x25 receptacle (PB1/PC1) of **S5U13781M00C100 Board B/C** to J2 (2x25 header) on the bottom side of **S5U13781M00C100 Board A**. Make sure pin 1 of J2 of **S5U13781M00C100 Board A** lines up with pin 1 of PB1/PC1 of **S5U13781M00C100 Board B/C**.

- 13) Plug the bottom headers (J9, J10) of the **S5U13781R00C100 LCD Interface Board** to the top side receptacles (PB2/PC2, PC3) of **S5U13781M00C100 Board B/C**.
- 14) Connect the LCD module's FPC to J8 of the **S5U13781R00C100 LCD Interface Board**. Make sure the pads/contacts side of the FPC are facing down and pin 1 of the FPC lines up with the pin 1 edge of J8 (please refer to Figure 4).

4 StellarisWare Drivers and Demo Software

The S1D13781 BoosterPack LCDC Development Package was developed with a companion software package that is available from the Epson website at vdc.epson.com. This software package includes a S1D13781 demonstration application and graphics library driver software source code intended for use in combination with TI StellarisWare and the Stellaris LM4F120 Launchpad.

4.1 Requirements

4.1.1 Hardware Requirements

The S1D13781 BoosterPack LCDC Development Package software was developed for use with the following hardware.

- Stellaris LM4F120 Launchpad
- S5U13781R00C10M
- Compatible LCD Display

For details on preparing the hardware for use, see Section **Error! Reference source not found., Error! Reference source not found.**

4.1.2 Software Requirements

The S1D13781 BoosterPack LCDC Development Package software was developed for use with the following software tools.

- Code Composer Studio – see <http://www.ti.com/tool/ccstudio>
- StellarisWare – see <http://www.ti.com/stellaris>
- ICDI USB drivers (for debugging) – see http://www.ti.com/tool/stellaris_icdi_drivers

4.2 Software Installation

The following steps are required to install the S1D13781 BoosterPack LCDC Development Package software and the required software tools. If the TI software tools have already been installed, skip to step 4.

Note:

The following instructions assume a PC running Windows XP (or higher). For compatibility with other operating systems or development platforms, please refer to TI's website at <http://www.ti.com/stellaris>.

1. Install the Code Composer Studio IDE.
2. Install StellarisWare
3. Connect the Launchpad to the PC via a USB connector. When prompted, install the Stellaris ICDI drivers. On some systems, the drivers must be manually installed using the Windows Device Manager.
4. Extract the S1D13781 BoosterPack software into the StellarisWare working folder for the Launchpad board model being used (i.e. C:/StellarisWare/boards/ek-lm4f120xl/).
5. Open Code Composer Studio.

6. Select Import Project from the TI Resource Explorer or Import... > Code Composer Studio > Existing CCS Eclipse Projects from the File Menu. The following window will appear.

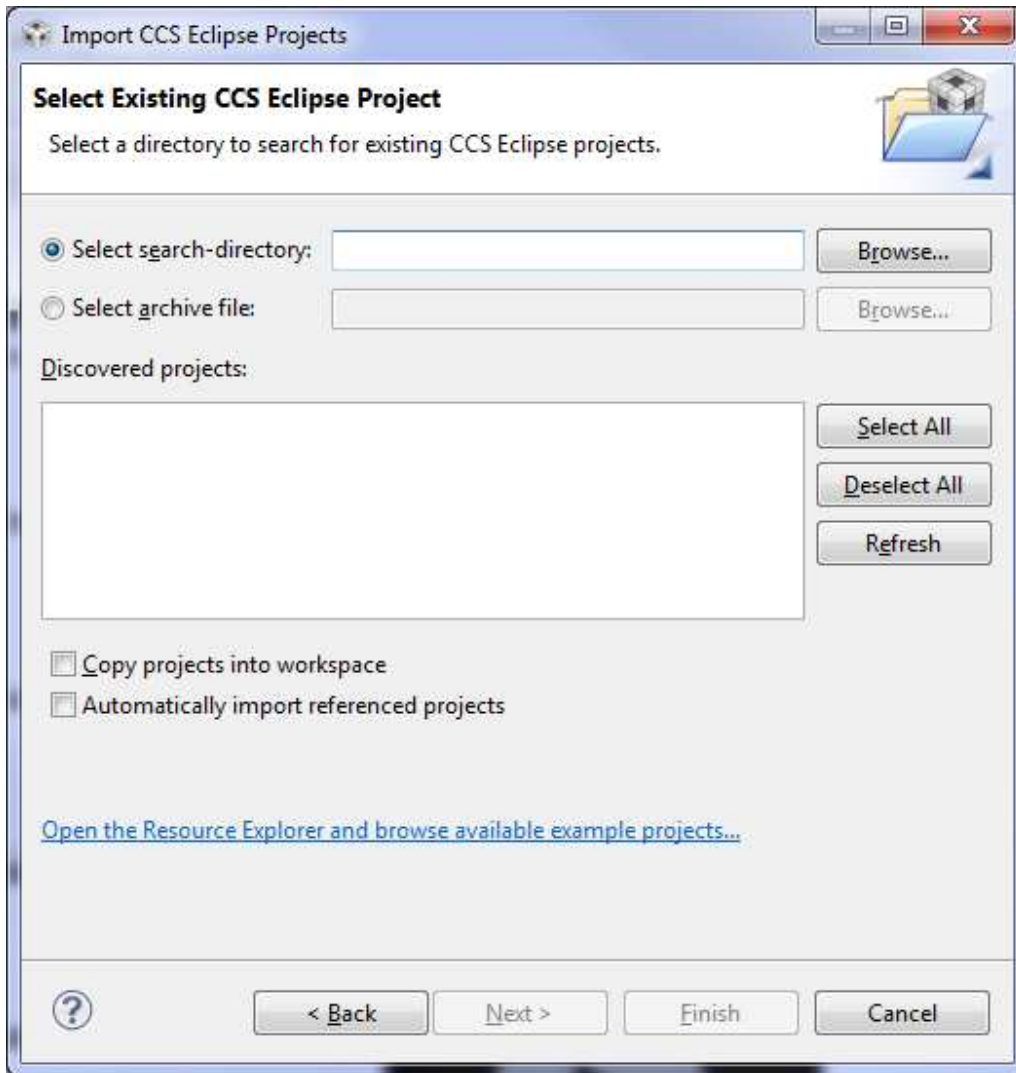

7. Browse to the folder where the S1D13781 BoosterPack software is installed (i.e. C:/StellarisWare/boards/ek-lm4f120xl/BoosterPack_S1D13781/) and click OK.
8. The s1d13781_demo project should now be shown in the “Discovered Projects” list. Select s1d13781_demo and click Finish.
9. The s1d13781_demo project should now be listed in the CCS Project Explorer.

4.3 Software Description

The S1D13781 BoosterPack LCDC Development Package software consists of the 2 parts: driver software and demonstration software.

4.3.1 Driver Software

Drivers are required to integrate the S1D13781R00C reference board into the Stellaris Launchpad environment. Several drivers are required to support the S1D13781 LCDC functions, integrate the S1D13781 into the StellarisWare development system, and interface to the Serial Flash memory included on the S5U13781R00C100 reference board.

S1D13781 LCDC

Driver source code is provided that supports the main features of the S1D13781. The source code is found in the “./BoosterPack_S1D13781/drivers” folder and supports features such as: (see “readme.txt” file)

- SPI Host interface (used to connect with the Stellaris MCU). This includes low level functions such as register and memory read/write access and initialization of the S1D13781.
- Main Layer configuration
- PIP Layer configuration
- Alpha Blend, Transparency, Rotation, PIP modes, etc.

The “S1D13781.h” file defines register initialization values for the 3.5” and 4.3” LCD modules. Each type of LCD module has a “#define xxxxx_PANEL” macro in the “Panel/System Selection” section of “S1D13781.h”. Only one should be uncommented and the rest commented out. For example, to select 4.3” LCD module, uncomment “#define WQVGA_PANEL” and comment out “#define QVGA_PANEL”.

The specific features supported may change without notice and may be added to as additional functionality is required.

StellarisWare Integration

Driver source code is provided that integrates the S1D13781 drivers and the StellarisWare graphics library. The following functions, as defined in the StellarisWare structure tDisplay, are supported:

- Draw Single Pixel
- Draw Multiple Pixels
- Draw a Horizontal Line
- Draw a Vertical Line
- Draw a Filled Rectangle
- 24-bit RGB to Display Color Translation
- Flush Cached Drawing

For details on these functions, refer to the StellarisWare graphics library (see grlib.h).

Serial Flash Memory

Driver source code is provided that supports read/write access to the 2MByte serial flash memory included on the S5U13781R00C reference board. The driver also supports other IO functions common to a serial flash memory device.

4.3.2 Demonstration Software

Source code for an application that demonstrate the main features of the S1D13781 LCDC is contained in the “./BoosterPack_S1D13781/s1d13781_demo” folder. The purpose of this application is twofold:

- it provides a working example of the main features of the S1D13781 LCDC
- it provides source code which the user can utilize as the starting point to programming the S1D13781 LCDC from within the TI StellarisWare development system

Feature Support

The demonstration application source code provides example implementation for the following S1D13781 features.

- S1D13781 initialization
- Serial flash initialization
- Drawing to the Main Layer
- Drawing to the PIP Layer (including PIP position, PIP rotation, PIP transparency, and various PIP modes (i.e. fade, blink, etc.))
- Alpha Blend (including various blend levels)
- Backlight control

The specific features supported may change without notice and may be added to as additional functionality is required.

4.4 Software Modification

Once all the tools and components are setup and configured, the Code Composer Studio IDE allows modification, building, and debugging of the source code. All source code developed for the S1D13781 BoosterPack LCDC Development Package is provided “as is” and may be modified and/or re-used in developing applications for use with the S5U13781R00C10M.

4.5 Software License

For license information about the source code developed for the S1D13781 BoosterPack LCDC Development Package, see the copyright information included in the source code.

5 Stellaris LM4F120 Launchpad Connections

The following tables show the signals of the Stellaris LM4F120 Launchpad connectors which are used by the S5U13781R00C10M BoosterPack LCDC Development Package:

J1	Stellaris LM4F120 Launchpad Signal	S1D13781 LCDC BoosterPack Usage
1	VCC (3.3V)	VCC (3.3V)
2	PB5/AIN1/SSI2Fss/T1CCP1/CAN0Tx	SPI1_CS#
3	PB0/U1Rx/T2CCP0	-
4	PB1/U1Tx/T2CCP1	-
5	PE4/AIN9/U5Rx/I2C2SCL/CAN0Rx	-
6	PE5/AIN8/U5Tx/I2C2SDA/CAN0Tx	-
7	PB4/AIN10/SSI2Clk/T1CCP0/CAN0Rx	SPI1_CLK
8	PA5/SSI0Tx	SPI2_SIMO
9	PA6/I2C1SCL	-
10	PA7/I2C1SDA	-

J2	Stellaris LM4F120 Launchpad Signal	S1D13781 LCDC BoosterPack Usage
1	GND	GND
2	PB2/I2C0SCL/T3CCP0	LED_CTRL
3	PE0/AIN3/U7Rx	-
4	PF0/U1RTS/SSI1Rx/CAN0Rx/T0CCP0/ NMI/C0o	-
5	RESET#	-
6	PB7/SSI2Tx/T0CCP1	SPI1_SIMO
7	PB6/SSI2Rx/C0CCP0	SPI1_SOMI
8	PA4/SSI0Rx	SPI2_SOMI
9	PA3/SSI0Fss	SPI2_CS#
10	PA2/SSI0Clk	SPI2_CLK

J3	Stellaris LM4F120 Launchpad Signal	S1D13781 LCDC BoosterPack Usage
1	VBUS (5.0V)	-
2	GND	GND
3	PD0/AIN7/SSI3Clk/SSI1Clk/I2C3SCL/ WT2CCP0	MIO0*
4	PD1/AIN6/SSI3Fss/SSI1Fss/I2C3SDA/ WT2CCP1	MIO1*
5	PD2/AIN5/SSI3Rx/SSI1Rx/WT3CCP0	MIO2*
6	PD3/AIN4/SSI3Tx/SSI1Tx/WT3CCP1	MIO3*
7	PE1/AIN2/U7Tx	MIO4*
8	PE2/AIN1	-
9	PE3/AIN0	-
10	PF1/U1CTS/SSI1Tx/T0CCP1/C1o/TRD1	SPI3_SIMO

*MIOx signals are multi-function, depending what type of LCD module is connected. Demo firmware and drivers currently do not support these signals.

J4	Stellaris LM4F120 Launchpad Signal	S1D13781 LCDC BoosterPack Usage
1	PF2/ SSI1Clk /T1CCP0/TRD0	SPI3_CLK
2	PF3 / SSI1Fss /CAN0Tx/T1CCP1/TRCLK	SPI3_CS#
3	PB3/I2C0SDA/T3CCP1	-
4	PC4/C1-/U4Rx/U1Rx/WT0CCP0/U1RTS	-
5	PC5/C1+/U4Tx/U1Tx/WT0CCP1/U1CTS	-
6	PC6/C0+/U3Rx/WT1CCP0	-
7	PC7/C0-/U3Tx/WT1CCP1	-
8	PD6/U2Rx/WT5CCP0	-
9	PD7/U2Tx/WT5CCP1/NMI	-
10	PF4/T2CCP0	-

The SPI1_* signals are the SPI interface signals for the S1D13781 LCD Controller on the S5U13781R00C100 Main Board.

The SPI2_* signals are the SPI interface signals for the M25P16 Serial Flash (2Mbytes) on the S5U13781R00C100 Main Board.

The LED_CTRL signal is for controlling (by pulse-width modulation) the LED backlight current (LED+, LED- signals to the LCD module). The LED backlight driver circuit is on the S5U13781R00C100 Main Board.

The MIO* signals are multi-function signals which can be used for resistive touch interface, SPI interface to LCD module's LCD driver chip, or general-purpose I/O. They are mainly intended to support variations in pinout of various 54-pin LCD modules (see Section 6 and 7). Currently, demo firmware and drivers do not support or make use of these signals.

The SPI3_* signals are intended to be used as the SPI interface to the LCD driver chip on some 54-pin LCD modules (see Section 6 and 7). Currently, demo firmware and drivers do not support or make use of these signals.

6 Pinout for 40-Pin LCD Interface

The following table shows the pinout and signal connections of the 40-pin FPC:

FPC Pin	Newhaven Display NHD-4.3-480272EF-ATXL# NHD-4.3-480272EF-ATXL#-T	Stellaris LM4F120 Launchpad Connection	S5U13781R00C100 Main Board Connection
1	LED-	-	J5-47,48
2	LED+	-	J5-45,46
3	GND	GND	GND
4	VDD (3.3V)	VDD (3.3V)	VDD (3.3V)
5	R0	-	J5-25
6	R1	-	J5-26
7	R2	-	J5-27
8	R3	-	J5-28
9	R4	-	J5-29
10	R5	-	J5-30
11	R6	-	J5-31
12	R7	-	J5-32
13	G0	-	J5-17
14	G1	-	J5-18
15	G2	-	J5-19
16	G3	-	J5-20
17	G4	-	J5-21
18	G5	-	J5-22
19	G6	-	J5-23
20	G7	-	J5-24
21	B0	-	J5-9
22	B1	-	J5-10
23	B2	-	J5-11
24	B3	-	J5-12
25	B4	-	J5-13
26	B5	-	J5-14
27	B6	-	J5-15
28	B7	-	J5-16
29	GND	GND	GND
30	PCLK	-	J5-6
31	DISPEN	-	J5-49 (S1D13781 GPIO0 output)
32	HSYNC	-	J5-4
33	VSYNC	-	J5-3
34	DE	-	J5-5
35	-	-	-
36	GND	GND	GND
37	<i>XR*</i>	<i>J3-4 (PD1/AIN6)</i>	-
38	<i>YD*</i>	<i>J3-3 (PD0/AIN7)</i>	-
39	<i>XL*</i>	<i>J3-6 (PD3/AIN4)</i>	-
40	<i>YU*</i>	<i>J3-7 (PE1/AIN2)</i>	-

*Optional resistive touch analog voltages.

In addition to the Newhaven NHD-4.3-480272EF-ATXL#[-T], the following LCD modules from other manufacturers are also supported by the 40-pin hardware pinout:

- All Shore ASI-T-430FA6NT/H
- AZ Displays ATM0430D5 (ATM0430D5-T for resistive touch screen option)
- Logic Technologies LTDD480272043-L1
- Tianma TM043NBH02

Demo firmware and drivers only support LCD timings for Newhaven NHD-4.3-480272EF-ATXL#[-T]. The other LCD modules may have different timings and might require different programming values for the S1D13781 registers.

The 4 resistive touch analog signals are routed from the 40-pin FPC of the LCD module to the Stellaris LM4F120 Launchpad analog input ports, but there is currently no demo firmware and driver provided for the touch interface.

7 Pinout for 54-Pin LCD Interface

The following table shows the pinout and signal connections of the 54-pin FPC:

FPC Pin	Newhaven Display NHD-3.5-320240MF-ATXL#-1	Stellaris LM4F120 Launchpad Connection	S5U13781R00C100 Main Board Connection
1	LED-	-	J5-47,48
2	LED-	-	J5-47,48
3	LED+	-	J5-45,46
4	LED+	-	J5-45,46
5	-	-	-
6	-	*J3-5 (PD2/SSI3Rx)	-
7	-	-	-
8	RST#	*J3-7 (PE1/AIN2)	-
9	SPI_CS#	*J3-4 (PD1/AIN6)	-
10	SPI_CLK	*J3-3 (PD0/AIN7/SSI3Clk)	-
11	SPI_SIMO	*J3-6 (PD3/AIN4/SSI3Tx)	-
12	B0	-	J5-9
13	B1	-	J5-10
14	B2	-	J5-11
15	B3	-	J5-12
16	B4	-	J5-13
17	B5	-	J5-14
18	B6	-	J5-15
19	B7	-	J5-16
20	G0	-	J5-17
21	G1	-	J5-18
22	G2	-	J5-19
23	G3	-	J5-20
24	G4	-	J5-21
25	G5	-	J5-22
26	G6	-	J5-23
27	G7	-	J5-24
28	R0	-	J5-25
29	R1	-	J5-26
30	R2	-	J5-27
31	R3	-	J5-28
32	R4	-	J5-29
33	R5	-	J5-30
34	R6	-	J5-31
35	R7	-	J5-32
36	HSYNC	-	J5-4
37	VSYNC	-	J5-3
38	PCLK	-	J5-6
39	-	-	-
40	-	-	-
41	VDD (3.3V)	VDD (3.3V)	VDD (3.3V)
42	VDD (3.3V)	VDD (3.3V)	VDD (3.3V)
43	-	*J4-2 (PF3)	-
44	-	-	-
45	-	-	-

47	-	-	-
48	-	-	-
49	-	*J4-1 (PF2/SSI1Clk)	-
50	-	*J3-10 (PF1/SSI1Tx)	-
51	-	-	-
52	DE	-	J5-5
53	GND	GND	GND
54	GND	GND	GND

**These are multi-function signals depending on the LCD module connected. Demo firmware and drivers currently do not support these signals.*

In addition to the Newhaven NHD-3.5-320240MF-ATXL#-1, the following LCD modules from other manufacturers are also supported by the 54-pin hardware pinout:

- Hantronix HDA351-LV
- Evervision VGG322425-6UFLWA
- Topway LMT035KDH03
- Tianma TM035KDH03
- All Shore ASI-T-350EA3NN/D
- Powertip PH320240T-006-I-Q
- AMP/Ampire AM320240L2TMQW-TB0H
- Logic Technologies LTTD320240035-L1RT
- US Micro USMP-TT035Q-01D
- TechToys LVC75Z779V2S
- Microtips MTF-TQ35SP741-AV

Demo firmware and drivers only support LCD timings for the Newhaven NHD-3.5-320240MF-ATXL#-1. The other LCD modules may have different timings and might require different programming values for the S1D13781 registers.

The following table shows the pinouts of the different variations of the 54-pin FPC connection of LCD modules from the various manufacturers:

FPC Pin	Hantronix HDA351-LV Evervision VGG322425-6UFLWA	Topway LMT035KDH03 Tianma TM035KDH03 Newhaven NHD-3.5-320240MF-ATXL#-1 All Shore ASI-T-350EA3NN/D	Powertip PH320240T-006-I-Q	AMP / Ampire AM320240L2TMQ W-TB0H	Logic Technologies LTTD320240035-L1RT US Micro USMP-TT035Q-01D TechToys LVC75Z779V1S / Microtips MTF-TQ35SP741-AV
1	LED-	LED-	LED-	LED-	LED-
2	LED-	LED-	LED-	LED-	LED-
3	LED+	LED+	LED+	LED+	LED+
4	LED+	LED+	LED+	LED+	LED+
5	-	-	-	-	-
6	-	-	-	SPI_SOMI	RST#
7	-	-	-	-	-
8	RST#	RST#	RST#	RST#	YU*
9	-	SPI_CS#	SPI_CS#	SPI_CS#	XR*
10	-	SPI_CLK	SPI_CLK	SPI_CLK	YD*
11	-	SPI_SIMO	SPI_SIMO	SPI_SIMO	XL*
12	B0	B0	B0	B0	B0
13	B1	B1	B1	B1	B1
14	B2	B2	B2	B2	B2
15	B3	B3	B3	B3	B3
16	B4	B4	B4	B4	B4
17	B5	B5	B5	B5	B5
18	B6	B6	B6	B6	B6
19	B7	B7	B7	B7	B7
20	G0	G0	G0	G0	G0
21	G1	G1	G1	G1	G1
22	G2	G2	G2	G2	G2
23	G3	G3	G3	G3	G3
24	G4	G4	G4	G4	G4
25	G5	G5	G5	G5	G5
26	G6	G6	G6	G6	G6
27	G7	G7	G7	G7	G7
28	R0	R0	R0	R0	R0
29	R1	R1	R1	R1	R1
30	R2	R2	R2	R2	R2
31	R3	R3	R3	R3	R3
32	R4	R4	R4	R4	R4
33	R5	R5	R5	R5	R5
34	R6	R6	R6	R6	R6
35	R7	R7	R7	R7	R7
36	HSYNC	HSYNC	HSYNC	HSYNC	HSYNC
37	VSYNC	VSYNC	VSYNC	VSYNC	VSYNC
38	PCLK	PCLK	PCLK	PCLK	PCLK
39	-	-	-	-	-
40	-	-	-	-	-
41	VDD	VDD	VDD	VDD	VDD
42	VDD	VDD	VDD	VDD	VDD
43	-	-	VDD	-	SPI_CS#
44	-	-	VDD	-	-
45	-	-	-	-	-
47	-	-	-	-	-

48	-	-	-	-	-
49	-	-	-	-	SPI_CLK
50	-	-	-	-	SPI_SIMO
51	-	-	-	-	-
52	-	DE	DE	DE	DE
53	GND	GND	GND	GND	GND
54	GND	GND	GND	GND	GND

**Optional resistive touch analog voltages.*

The SPI interface is optional if the application firmware desires to control the LCD driver chip inside the LCD module. Most applications don't need this control and just rely on the default settings of the LCD driver chip.

8 S5U13781M00C100 Schematics

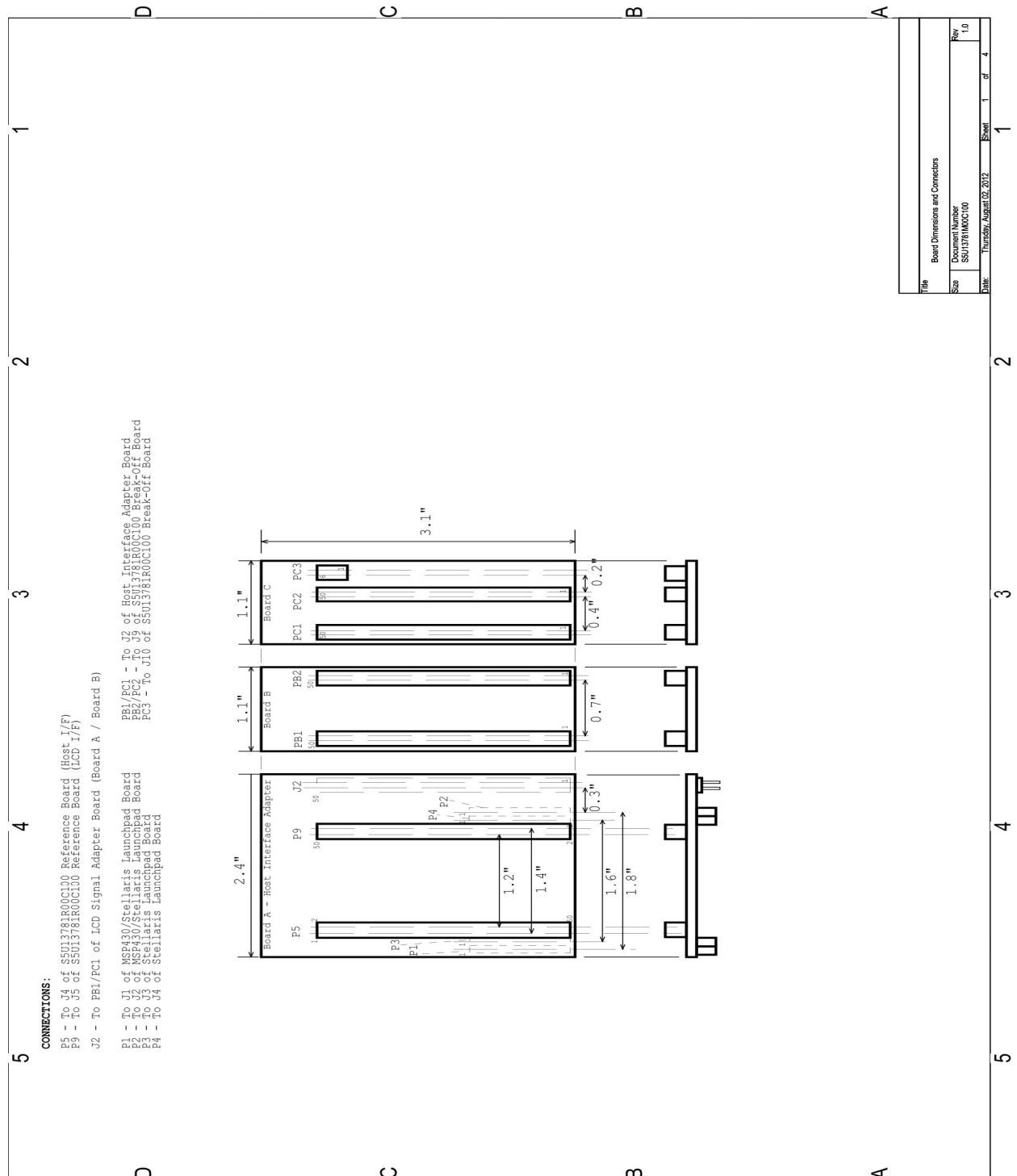

File		Board Dimensions and Connectors	
Size	Document Number	Rev	
	S5U13781M00C100	1.0	
Date	Thursday, August 02, 2012	Sheet	1 of 4

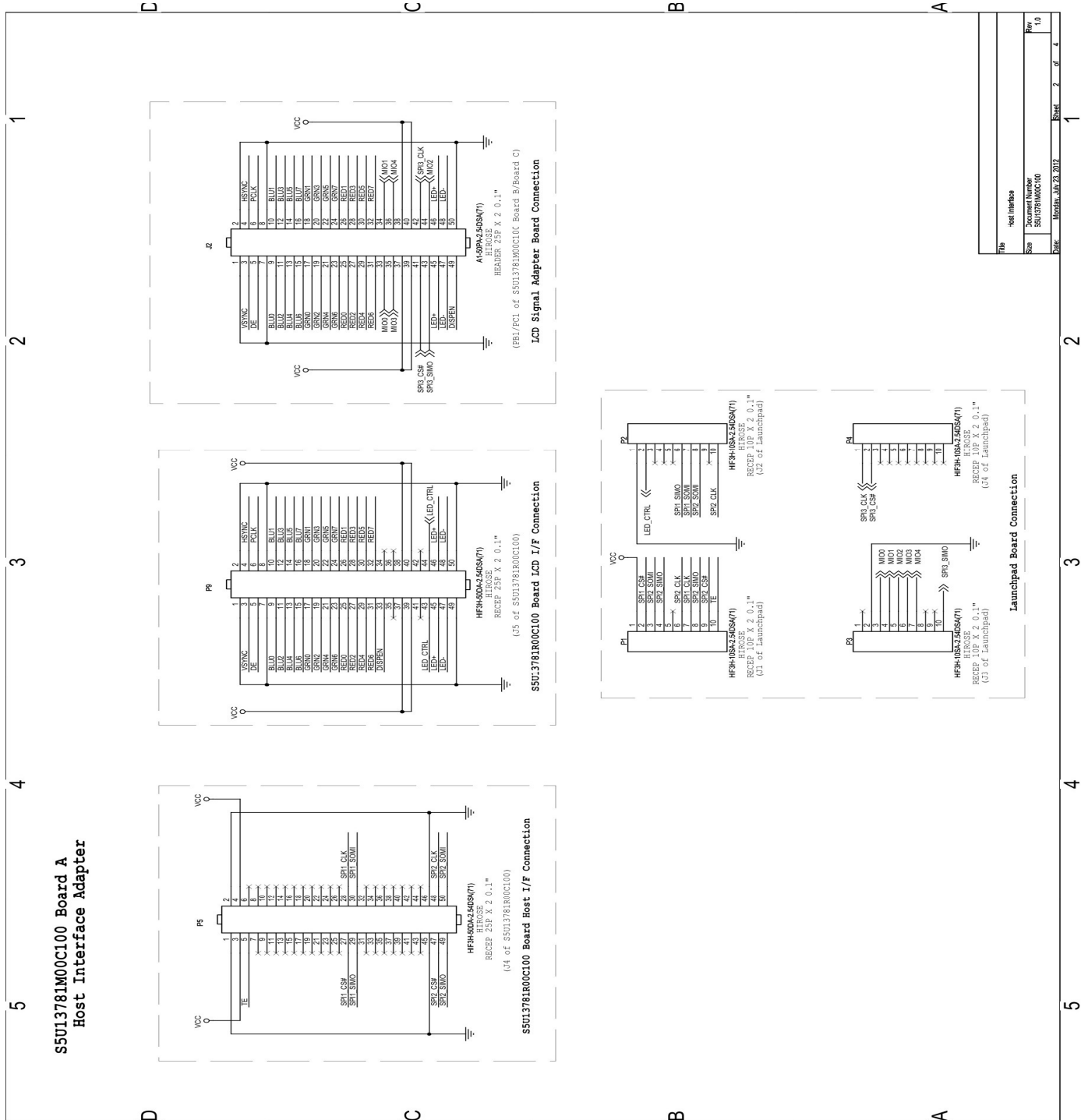

File	Host Interface
Doc No.	S5U13781M00C100
Rev	1.0
Print	Header 2 of 4

SSU13781M00C100 Board B
LCD Signal Adapter, 40-Pin

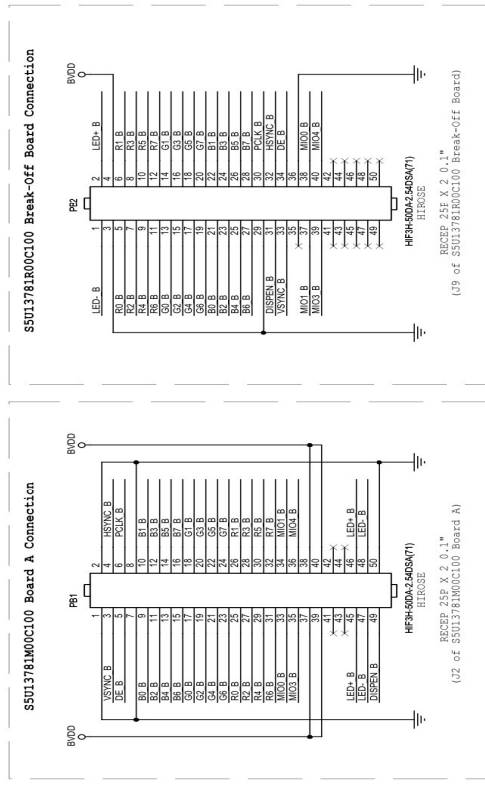

Title	..CD Signal Adapter - 40-Pin
Size	Document Number SSU13781M00C100
Rev	1.0
Date	March 23, 2012
Sheet	3 of 4

S5U13781M00C100 Board C
ICD Signal Adapter, 54-Pin

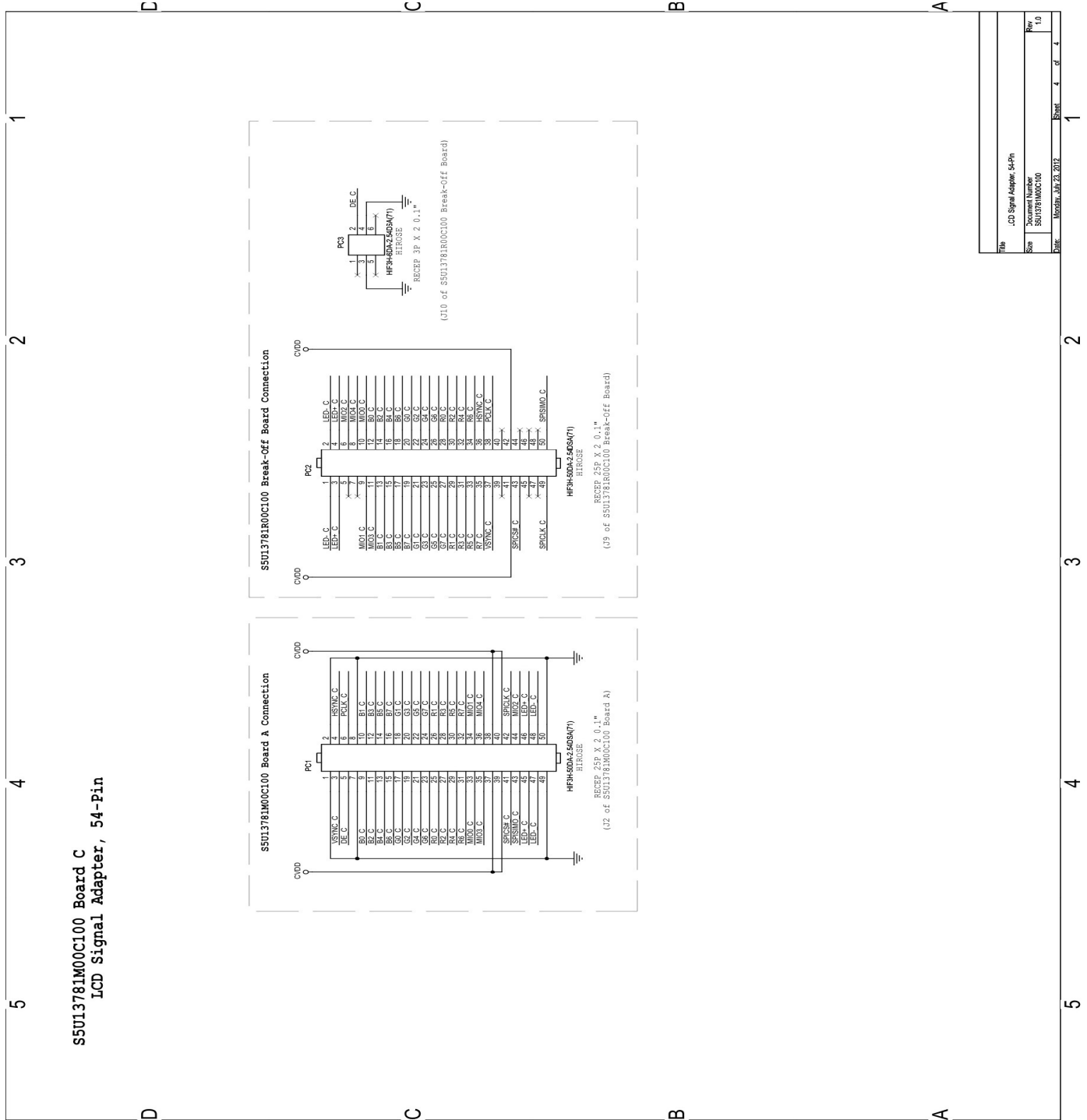

File	ICD Signal Adapter, 54-Pin
Document Number	S5U13781M00C100
Rev	1.0
Date	Monday, July 23, 2012
Sheet	4 of 4

9 S5U13781M00C100 Board Layout

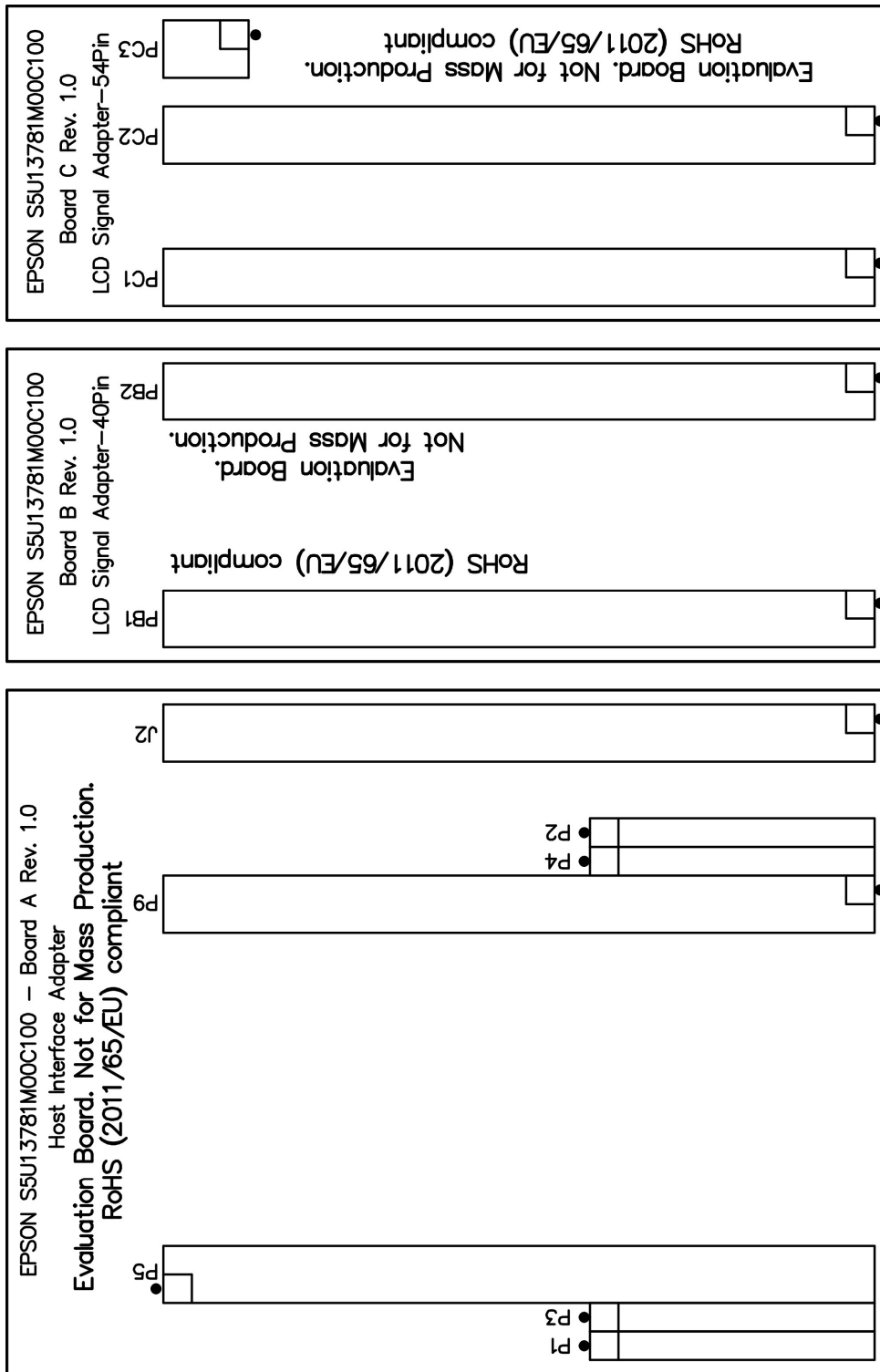

SEIKO EPSON CORPORATION S5U13781M00C100 Adapter Board Rev. 1.0

27-Jul-2012 Top Assembly Drawing

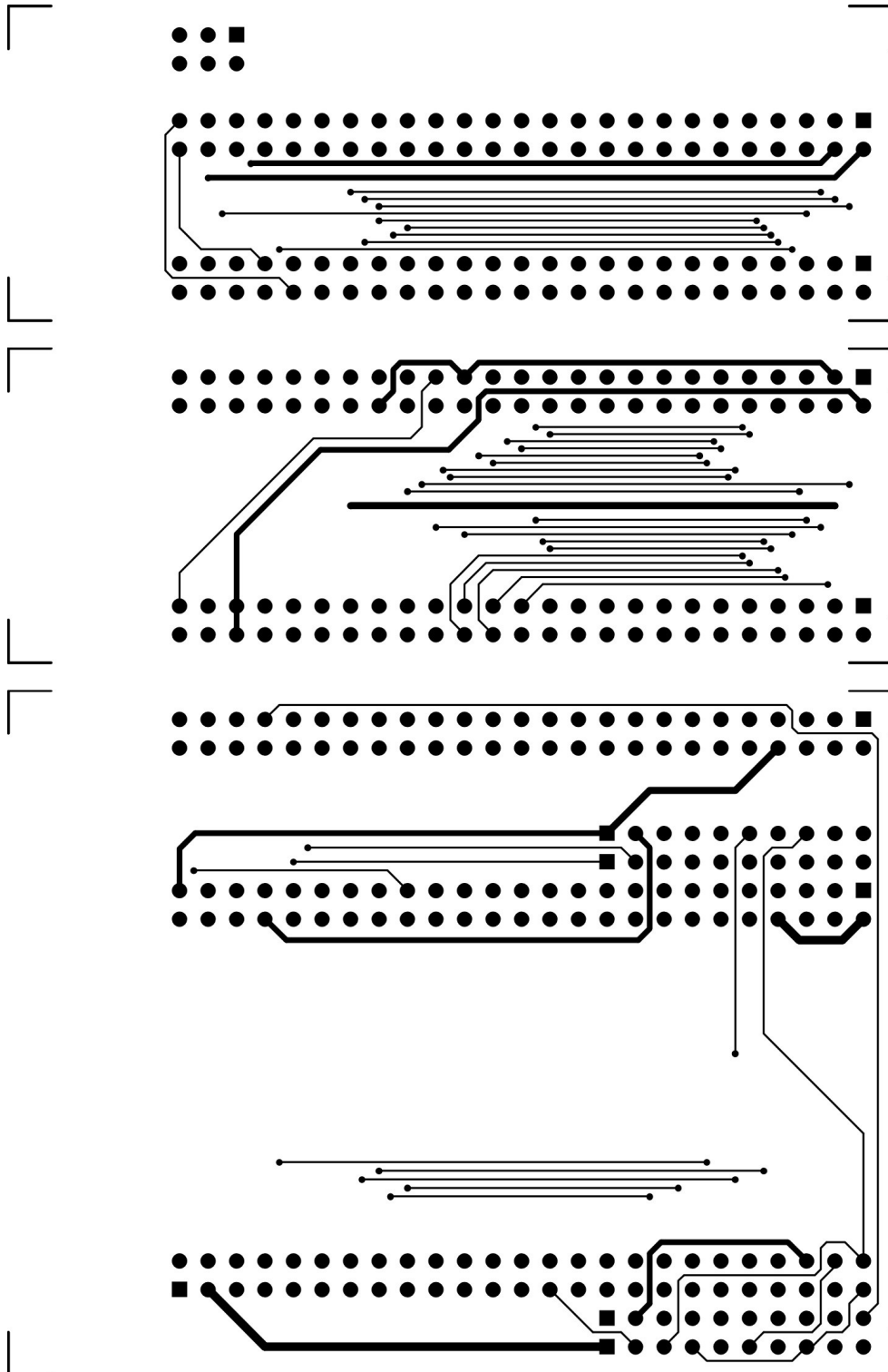

Top Layer

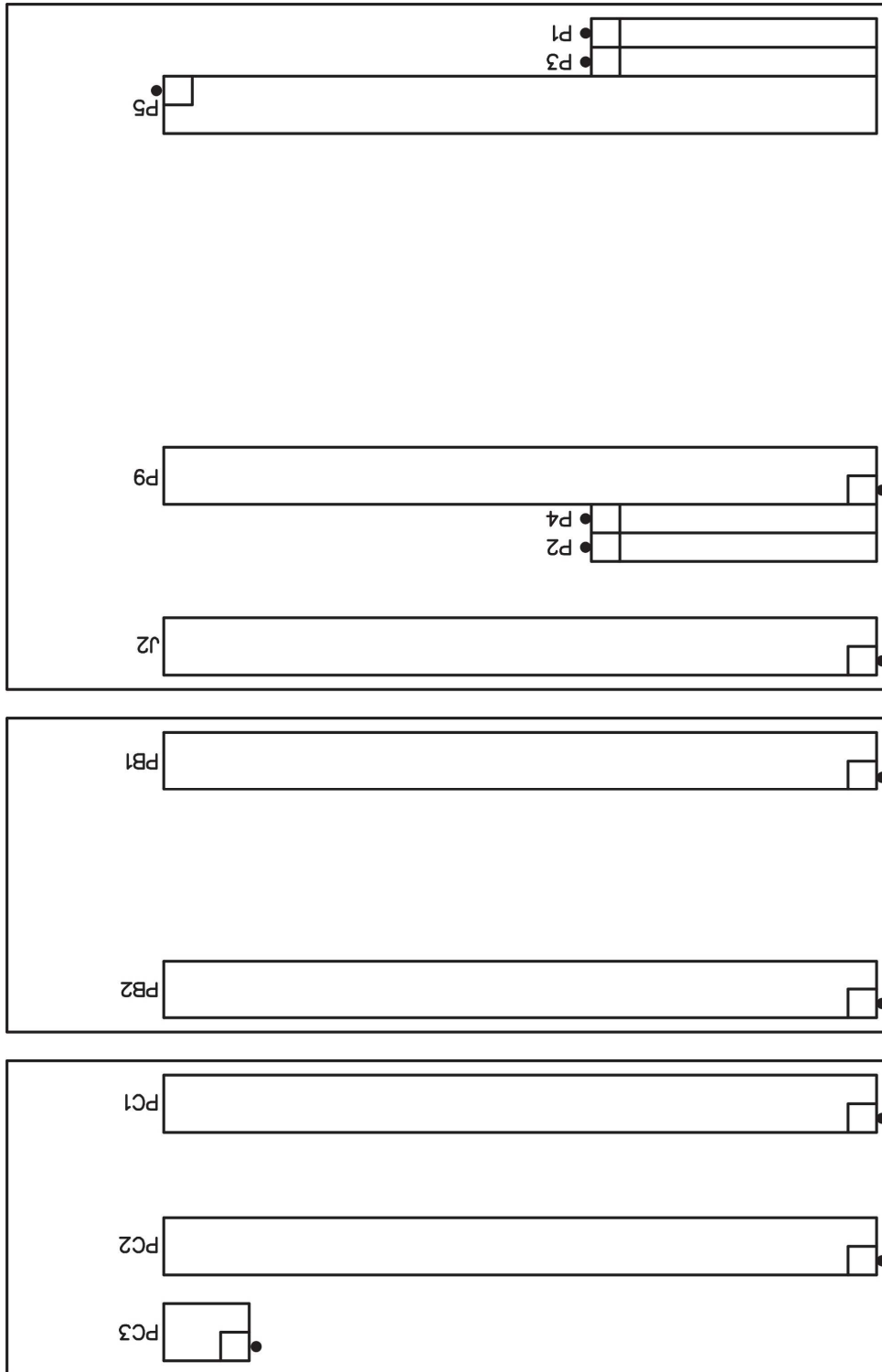

SEIKO EPSON CORPORATION S5U13781M00C100 Adapter Board Rev. 1.0

27-Jul-2012 Bottom Assembly Drawing

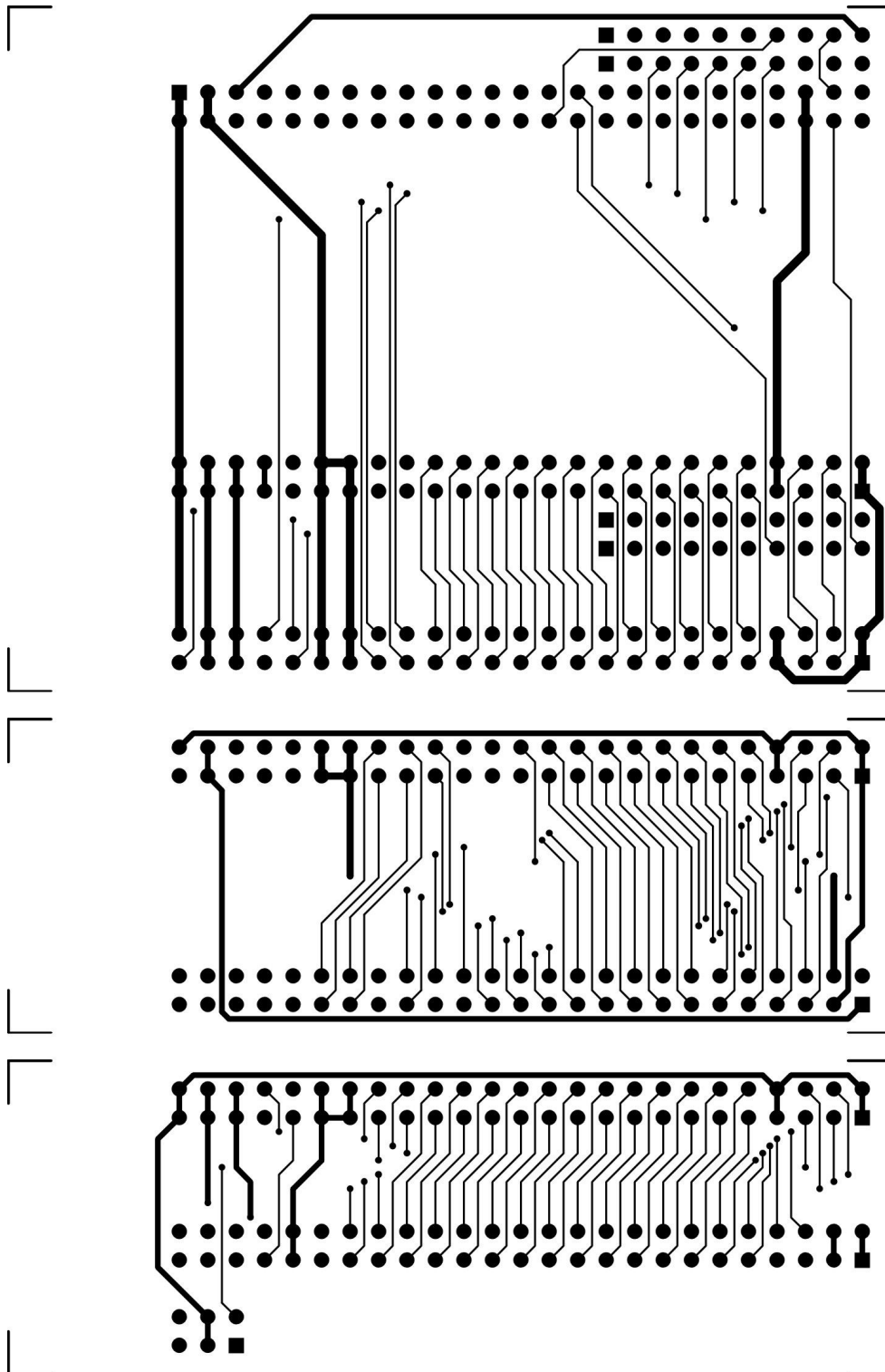

Bottom Layer

10 References

Epson Research and Development, Inc., S1D13781 Hardware Functional Specification, document number X94A-A-001-01.

Epson Research and Development, Inc., S5U13781R00C100 Reference Board User Manual, document number X94A-G-004-01.

11 Change Record

X94A-G-008-01 Revision 0.9 - Issued: September 7, 2012.

Revision 0.93 – September 14, 2012

- Adjusted table column widths.
- Modified Section 2 parts table to specify manufacturer part numbers instead of distributor part numbers, and added alternate LCD module manufacturers.
- Updated obsolete 4.3" Newhaven LCD part number with new one.
- Added instructions to connect J1 pins 1-2 of S5U13781R00C100 Main Board to supply power to the Serial Flash.
- Updated Figure 4 with new image.

AMERICA

EPSON ELECTRONICS AMERICA, INC.

214 Devcon Drive,
San Jose, CA 95112, USA
Phone: +1-800-228-3964 FAX: +1-408-922-0238

EUROPE

EPSON EUROPE ELECTRONICS GmbH

Riesstrasse 15, 80992 Munich,
GERMANY
Phone: +49-89-14005-0 FAX: +49-89-14005-110

ASIA

EPSON (CHINA) CO., LTD.

7F, Jinbao Bldg., No.89 Jinbao St.,
Dongcheng District,
Beijing 100005, CHINA
Phone: +86-10-8522-1199 FAX: +86-10-8522-1125

SHANGHAI BRANCH

7F, Block B, Hi-Tech Bldg., 900 Yishan Road,
Shanghai 200233, CHINA
Phone: +86-21-5423-5577 FAX: +86-21-5423-4677

SHENZHEN BRANCH

12F, Dawning Mansion, Keji South 12th Road,
Hi-Tech Park, Shenzhen 518057, CHINA
Phone: +86-755-2699-3828 FAX: +86-755-2699-3838

EPSON HONG KONG LTD.

Unit 715-723, 7/F Trade Square, 681 Cheung Sha Wan Road,
Kowloon, Hong Kong.
Phone: +852-2585-4600 FAX: +852-2827-4346

EPSON TAIWAN TECHNOLOGY & TRADING LTD.

14F, No. 7, Song Ren Road,
Taipei 110, TAIWAN
Phone: +886-2-8786-6688 FAX: +886-2-8786-6660

EPSON SINGAPORE PTE., LTD.

1 HarbourFront Place,
#03-02 HarbourFront Tower One, Singapore 098633
Phone: +65-6586-5500 FAX: +65-6271-3182

**SEIKO EPSON CORP.
KOREA OFFICE**

5F, KLI 63 Bldg., 60 Yoido-dong,
Youngdeungpo-Ku, Seoul 150-763, KOREA
Phone: +82-2-784-6027 FAX: +82-2-767-3677

**SEIKO EPSON CORP.
MICRODEVICES OPERATIONS DIVISION****IC Sales & Marketing Department**

421-8, Hino, Hino-shi, Tokyo 191-8501, JAPAN
Phone: +81-42-587-5814 FAX: +81-42-587-5117