

RoHS Compliant Product

Description

The S5U2179 series positive, linear regulators feature low quiescent current (45µA typ.) with low dropout voltage, making them ideal for battery applications. Output voltage are set at the factory and trimmed to 1.5% accuracy. These rugged devices have both Thermal Shutdown and Current Fold-back to prevent device failure under the "Worst" of operating conditions. In applications requiring a low noise, regulated supply, place a 1000pF capacitor between Bypass and Ground. The S5U2179 is stable with an output capacitance of 4.7µF or greater.

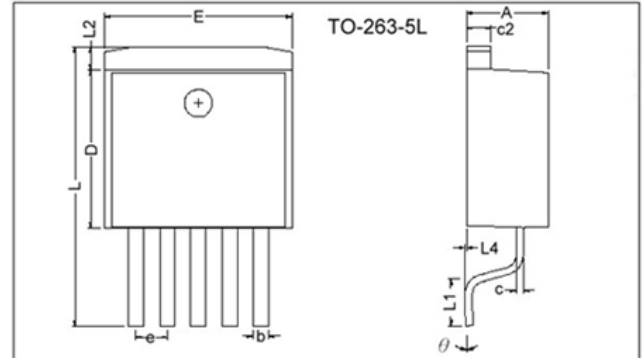

| REF. | Millimeter | | REF. | Millimeter | |
|------|------------|------|------|------------|------|
| | Min. | Max. | | Min. | Max. |
| A | 4.40 | 4.80 | c2 | 1.25 | 1.45 |
| b | 0.66 | 0.91 | L2 | 1.27 | REF. |
| L4 | 0.00 | 0.30 | D | 8.6 | 9.0 |
| c | 0.36 | 0.5 | e | 1.70 | REF. |
| L1 | 2.29 | 2.79 | L | 14.6 | 15.8 |
| E | 9.80 | 10.4 | θ | 0° | 8° |

Features

- * Low Temperature Coefficient
- * Over-Temperature Shutdown
- * Highly Accurate ± 1.5%
- * Very Low Dropout Voltage
- * Noise Reduction Bypass Capacitor
- * Guaranteed 1.55 A output
- * Current Limiting
- * Power-Saving Shutdown Mode

Applications

- * PC Peripherals
- * Wireless Devices
- * Portable Electronics
- * Battery Powered Widgets
- * Instrumentation

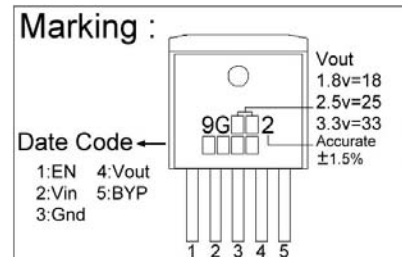

Typical Application Circuit

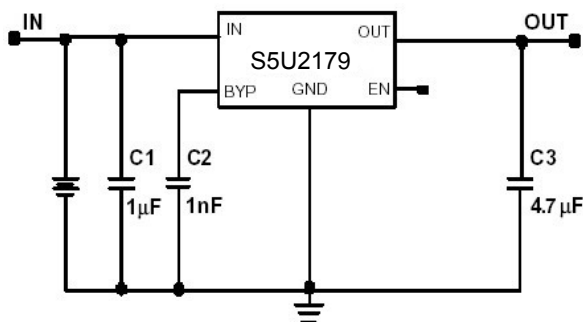

Functional Block Diagram

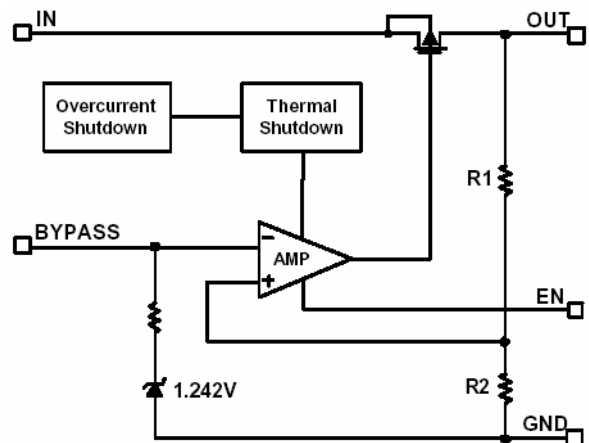

Absolute Maximum Ratings

| Parameter | Symbol | Ratings | Unit |
|---------------------------------------|--------------------|--|------|
| Input Max Voltage | V _{IN} | 8 | V |
| Output Current | I _{OUT} | P _D /(V _{IN} -V _O) | A |
| Output Voltage | V _{OUT} | 1.5~5.0 | V |
| Operating Ambient Temperature | T _{opr} | -40 ~ +85 | °C |
| Junction Temperature | T _j | -40 ~ +125 | °C |
| Maximum Junction Temperature | T _{j Max} | 150 | °C |
| Thermal Resistance | θ _{jc} | 5 | °C/W |
| Internal Power Dissipation(ΔT=100°C)* | PD | 3.0 | W |
| EDS Classification | | B | |

*Assuming a heat sink capable of twice times (θ_{jc})

Electrical Characteristics V_{IN}=V_{OUT}(T)+2V, V_{EN}=V_{IN}, T_A=25°C unless otherwise noted

| Parameter | Symbol | Condition | Min | TYP | Max | Unit | |
|--|---------------------------------|---|--------------------------------|---------------------------------|-----------------|--------|-------|
| Output Voltage | V _{OUT} (E) (Note1) | I _O =1mA | -1.5% | V _{OUT} (T) (Note2) | 1.5% | V | |
| Output Current | I _O | V _{OUT} >1.2V | 1.55 | - | - | A | |
| Current Limit | I _{LM} | V _{OUT} >1.2V | 1.55 | 2.0 | - | A | |
| Load Regulation | REG _{LOAD} | I _O =1mA to 1.5A | -1 | 0.2 | 1 | % | |
| Dropout Voltage | V _{DROPOUT} | I _O =1.55A V _O =V _{OUT} (E)-2% | 1.5V<V _{OUT} (T)≤2.0V | - | - | 1000 | mV |
| | | | 2.0V<V _{OUT} (T)≤2.8V | - | - | 800 | |
| | | | 2.8V<V _{OUT} (T) | - | - | 600 | |
| Quiescent Current | I _Q | I _O =0mA | - | 45 | 70 | μA | |
| Ground Pin Current | I _{GND} | I _O =1mA~1.5A | - | 45 | - | μA | |
| Line Regulation | REG _{LINE} | I _O =1mA V _{IN} =V _{OUT} (T)+1 to V _{OUT} (T)+2 | V _{OUT} (T)<2.0V | - | - | 0.15 | % |
| | | | 2.0V≤V _{OUT} (T) | - | 0.02 | 0.1 | |
| Input Voltage | V _{IN} | | Note3 | - | 7 | V | |
| Over Temperature Shutdown | OTS | | - | 150 | - | °C | |
| Over Temperature Hysterisis | OTH | | - | 30 | - | °C | |
| Output Voltage Temperature Coefficient | TC | | - | 30 | - | ppm/°C | |
| Power Supply Rejection | PSRR | I _O =100mA C _O =4.7μF ceramic | f=1kHz | - | 50 | - | dB |
| | | | f=10kHz | - | 20 | - | |
| | | | f=100kHz | - | 15 | - | |
| Power Supply Rejection | PSRR | I _O =100mA C _O =4.7μF ceramic C _{BYP} =0.01μF | f=1kHz | - | 75 | - | dB |
| | | | F=10kHz | - | 55 | - | |
| | | | f=100kHz | - | 30 | - | |
| Output Voltage Noise | e _N | f=10Hz~100kHz I _O =10mA, C _{BYP} =0μF | | | 30 | - | μVrms |
| Output Voltage Noise | e _N | f=10Hz~100kHz I _O =10mA, C _{BYP} =0.01μF | | | 30 | - | μVrms |
| EN Input Threshold | V _{EH} | V _{IN} =2.7V to 7V | 2.0 | - | V _{IN} | V | |
| | V _{EL} | V _{IN} =2.7V to 7V | 0 | - | 0.4 | V | |
| EN Input Bias Current | I _{EH} | V _{EN} =V _{IN} , V _{IN} =2.7V to 7V | - | - | 0.1 | μA | |
| | I _{EL} | V _{EN} = 0V, V _{IN} =2.7V to 7V | - | - | 0.5 | μA | |
| Shutdown Supply Current | I _{SD} | V _{IN} =5.0V, V _O =0, V _{EN} <V _{EL} | - | 30 | - | μA | |
| | | V _{IN} =2.5V, V _O =0, V _{EN} <V _{EL} | - | 0.5 | 2 | μA | |

Note 1: $V_{OUT(E)}$ = Effective Output Voltage (i.e. the output voltage when " $V_{OUT(T)} + 2.0V$ " is provided at the V_{IN} pin while maintaining a certain I_{OUT} value).

2: $V_{OUT(T)}$ = Specified Output Voltage

3: $V_{IN(MIN)} = V_{OUT} + V_{DROPOUT}$

Ordering Information(contd.)

| Part Number | Marking | Output Voltage | Part Number | Marking | Output Voltage |
|-------------|---------------|----------------|-------------|---------------|----------------|
| S5U2179-15 | 9G152 XXXX | 1.5V | S5U2179-18 | 9G182 XXXX | 1.8V |
| S5U2179-25 | 9G252 XXXX | 2.5V | S5U2179-33 | 9G332 XXXX | 3.3V |
| S5U2179-47 | 9G472 XXXX | 4.7V | S5U2179-50 | 9G502 XXXX | 5.0V |

Detailed Description

The S5U 2179 of COMS regulators contain a PMOS pass transistor, voltage reference, error amplifier, over-current protection and thermal shutdown. The P-channel pass transistor receives data from the error amplifier, over-current shutdown, and thermal protection circuits. During normal operation, the error amplifier compares the output voltage to a precision reference. Over-current and Thermal shutdown circuits become active when the junction temperature exceeds 140°C , or the current exceeds 2.2A. During thermal shutdown, the output voltage remains low. Normal operation is restored when the junction temperature drops below 120°C .

External Capacitors

The S5U 2179 is stable with an output capacitance to ground of 4.7 μF or greater. Ceramic capacitors have the lowest ESR, and will offer the best AC performance. Conversely, Aluminum Electrolytic capacitors exhibit the highest ESR, resulting in the poorest AC response. Unfortunately, large value ceramic capacitors are comparatively expensive. One option is to parallel a 0.1 μF ceramic capacitor with a 10 μF Aluminum Electrolytic. The benefit is low ESR, high capacitance, and low overall cost. A second capacitor is recommended between the input and ground to stabilize V_{IN} . The input capacitor should be at least 0.1 μF to have a beneficial effect. A third capacitor can be connected between the BY-PASS pin and GND. This capacitor can be a low cost Polyester Film variety between the value of 0.001–0.01 μF . A large capacitor improves the AC ripple rejection, but also makes the output come up slowly. This "Soft" turn-on is desirable in some applications to limit turn-on surges. All capacitors should be placed in closed proximity to the pins. A "Quiet" ground termination is desirable. This can be achieved with a "Star" connection.

Enable

When EN pin is pulled low, the PMOS pass transistor shuts off, and all internal circuits are powered down. In this state, the quiescent current is less than 1 μA . This pin behaves much like an electronic switch.

Characteristics Curve

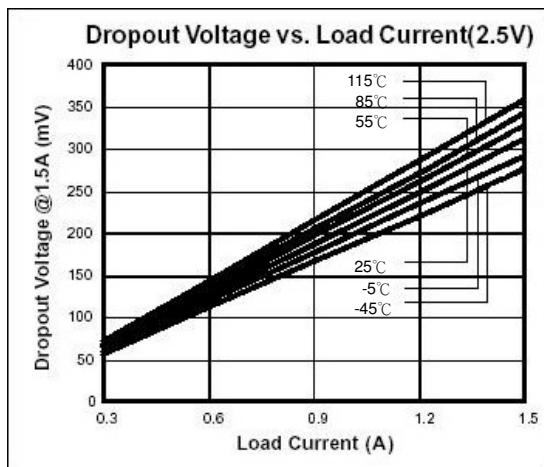
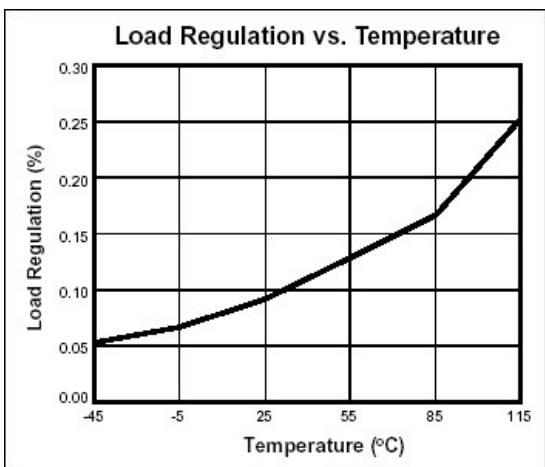
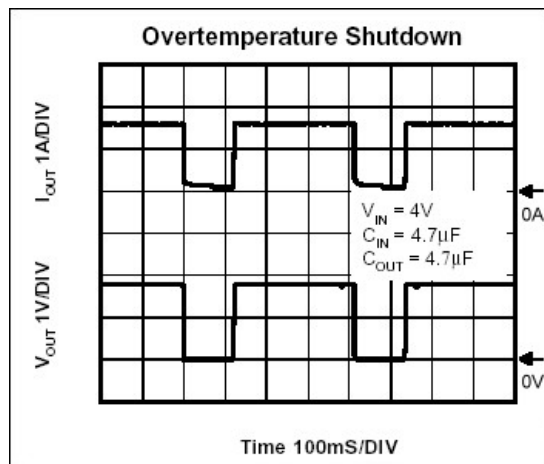
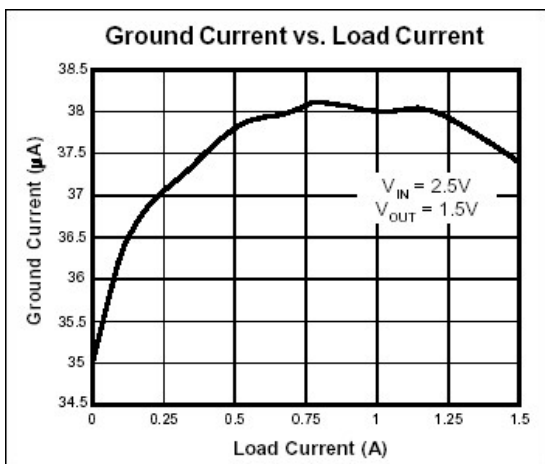
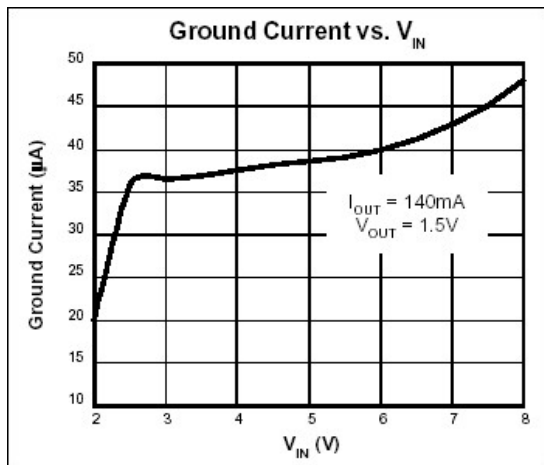
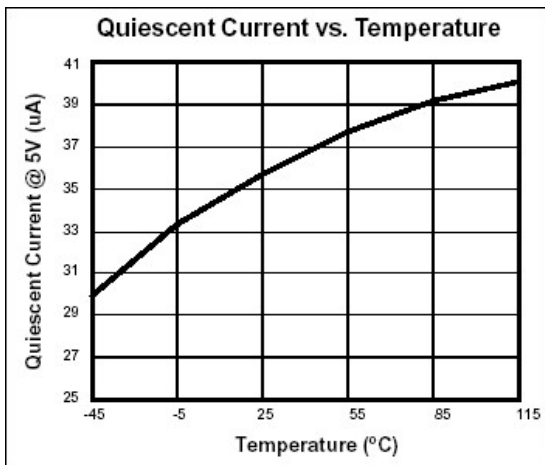

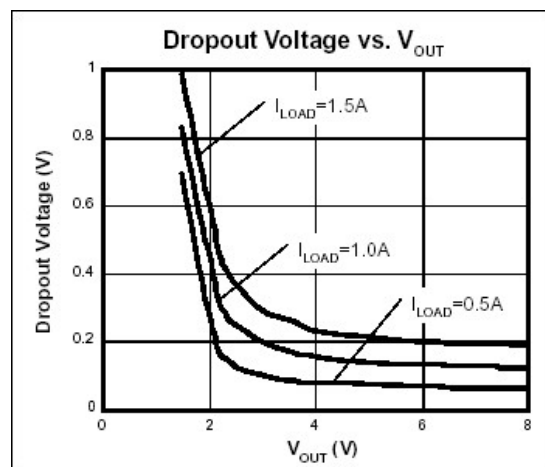
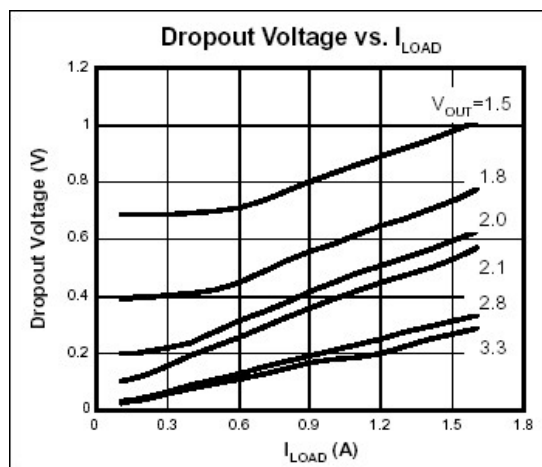
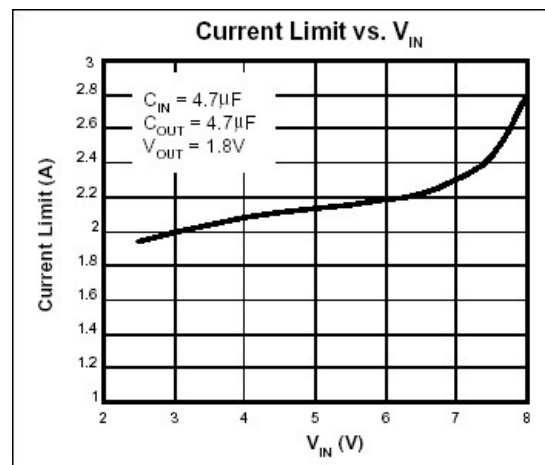
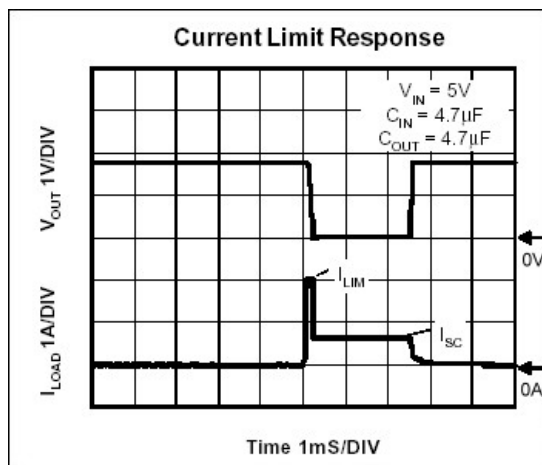
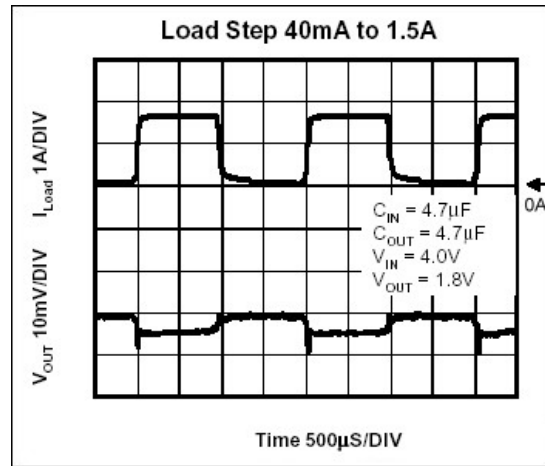
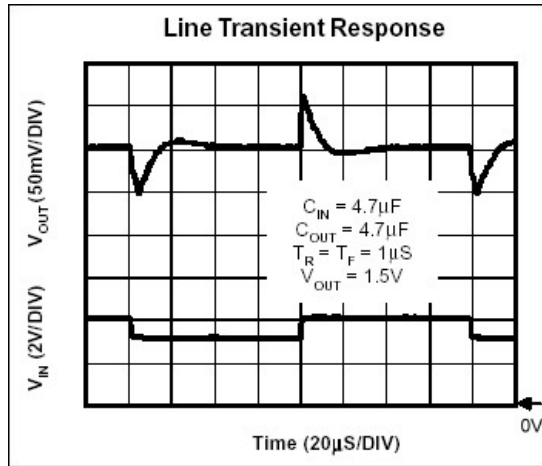

S5U2179

CMOS Low Dropout
Voltage Regulator

