

S5ULM2596

Simple Switcher Power Converter
150KHz 3A Step-Down Voltage Regulator

Description

The S5ULM2596 series of regulators are monolithic integrated circuits that provide all active functions for a step-down (buck) switching regulator, capable of driving 3A load with excellent line and load regulation. These devices are available in fixed output voltage of 3.3V, 5V, 12V and an adjustable output version. Requiring a min. number of external components, these regulators are simple to use and include internal frequency components and a fixed-frequency oscillator. The S5ULM2596 series operates at a switching frequency of 150KHz thus allowing smaller sized filter components than what would be needed with lower frequency switching regulators. Available in a standard 5-lead TO-263 package with several different lead bend options. A standard series of inductors are available from several different manufacturers optimized for use with the S5ULM2596 series. The feature greatly simplifies the design of switching-mode power supplies. Other features include a guaranteed $\pm 4\%$ to tolerance on output voltage within specified input voltages and output load condition, and $\pm 15\%$ on the oscillator frequency. External shutdown is included, featuring 80uA(Typ.) standby current. The output switch includes cycle-by-cycle current limiting, as well as thermal shutdown for full protection under fault condition.

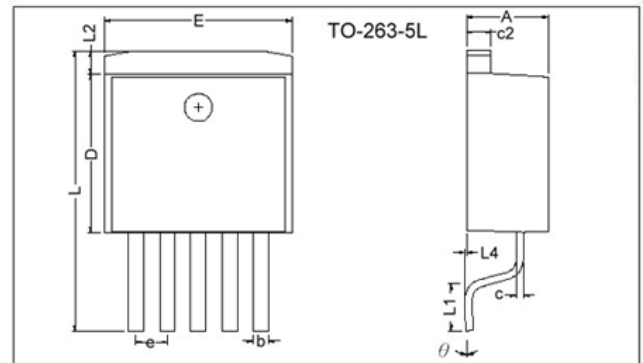

REF.	Millimeter		REF.	Millimeter	
	Min.	Max.		Min.	Max.
A	4.40	4.80	c2	1.25	1.45
b	0.66	0.91	L2	1.27	REF.
L4	0.00	0.30	D	8.6	9.0
c	0.36	0.5	e	1.70	REF.
L1	2.29	2.79	L	14.6	15.8
E	9.80	10.4	θ	0°	8°

Features

- * High Efficiency
- * Input Voltage Range Up To 40V
- * 150KHz Fixed Frequency Oscillator
- * 3.3V, 5V, 12V and Adjustable Output Versions
- * Uses Readily Available Standard Inductors
- * TTL Shutdown Capability, Low Power Standby Mode
- * Thermal Shutdown And Current Limit Protection
- * Guaranteed 3A Output Current
- * Efficient Per-regulator For Linear Regulators
- * Requires Only 4 External Components
- * Adjustable Version Output Voltage Range, 1.2V to 37V $\pm 4\%$ Max. Over Line And Load Conditions

Applications

- * Positive To Negative Converter
- * Simple High-Efficiency Step-Down (Buck) Regulator
- *

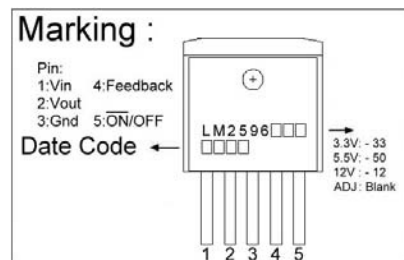

Typical Application (Fixed Output Voltage Version)

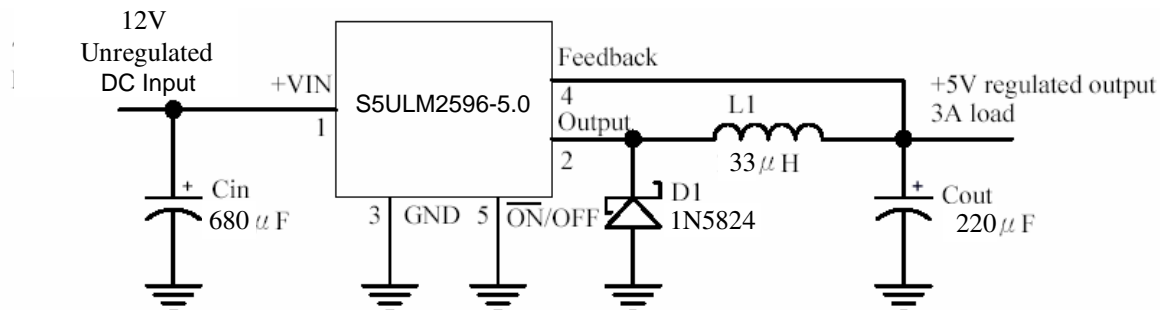
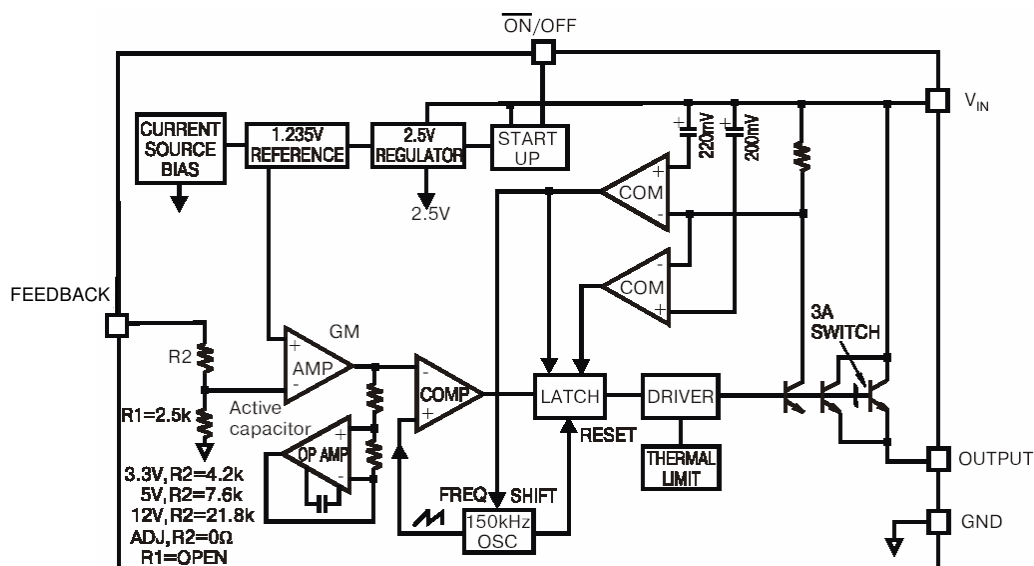

Figure. 1

Block Diagram



Pin Function

Pin Name	PIN#	FUNCTION
+VIN	1	This is the positive input supply for the IC switching regulator. A suitable input bypass capacitor must be present at this pin to minimize voltage transients and to supply the switching current needed by regulator.
Output	2	Internal switch. The voltage at this pin switches between (+VIN - VSAT) and approximately -0.5V, with a duty cycle of approximately VOUT/VIN. To minimize coupling to sensitive circuit, the PC board copper area connected to this pin should be kept to a minimum.
Ground	3	Circuit ground
Feedback	4	Senses the regulated output voltage to complete the feedback loop
ON/OFF	5	Allows the switching regulator circuit to be shutdown using logic level signals thus dropping the total input supply current to approximately 80 uA. Pulling this pin below a threshold voltage of approximately 1.3V turns the regulator on, and pulling this pin above 1.3V (up to a maximum of 25V) shuts the regulator down. If this shutdown feature is not needed, ON/OFF pin can be wired to the ground pin or it can be left open, in either case the regulator will be in the ON condition.

Absolute Maximum Ratings (Note1)

Parameter	Ratings	Unit
Maximum Supply Voltage	45	V
ON/OFF pin input Voltage	$-0.3 \leq V \leq +25$	V
Feedback pin Voltage	$-0.3 \leq V \leq +25$	V
Output Voltage to ground (steady state)	-1	V
Power dissipation	Internally Limited	
Storage Temperature	$-65 \sim +150$	°C
Maximum junction temperature	+150	°C
Minimum ESD rating (C=100pF, R=1.5kΩ)	2k	V
Lead temperature (soldering, 10seconds)	+260	°C

Operating Ratings

Parameter	Ratings	Unit
Temperature range	$-40 \leq T_J \leq +125$	°C
Supply Voltage	4.5 ~ 40	V

S5ULM2596-3.3 Electrical Characteristics

Specifications with standard type face are for $T_J=25^\circ\text{C}$, and those with **boldface type** apply over **full operating temperature range**

Parameter	Symbol	Conditions	Min (Note4)	Typ (Note3)	Max (Note4)	Unit
System Parameters (Note5) Test Circuit Figure 2						
Output Voltage	V_{OUT}	$4.75\text{V} \leq V_{IN} \leq 40\text{V}$ $0.2\text{A} \leq I_{LOAD} \leq 3\text{A}$	3.168/3.135	3.3	3.432/3.465	V
Efficiency	η	$V_{IN}=12\text{V}, I_{LOAD}=3\text{A}$		73		%

S5ULM2596-5.0 Electrical Characteristics

Specifications with standard type face are for $T_J=25^\circ\text{C}$, and those with **boldface type** apply over **full operating temperature range**

Parameter	Symbol	Conditions	Min (Note4)	Typ (Note3)	Max (Note4)	Unit
System Parameters (Note5) Test Circuit Figure 2						
Output Voltage	V_{OUT}	$7\text{V} \leq V_{IN} \leq 40\text{V}$ $0.2\text{A} \leq I_{LOAD} \leq 3\text{A}$	4.80/4.75	5.0	5.20/5.25	V
Efficiency	η	$V_{IN}=12\text{V}, I_{LOAD}=3\text{A}$		80		%

S5ULM2596-12 Electrical Characteristics

Specifications with standard type face are for $T_J=25^\circ\text{C}$, and those with **boldface type** apply over **full operating temperature range**

Parameter	Symbol	Conditions	Min (Note4)	Typ (Note3)	Max (Note4)	Unit
System Parameters (Note5) Test Circuit Figure 2						
Output Voltage	V_{OUT}	$15\text{V} \leq V_{IN} \leq 40\text{V}$ $0.2\text{A} \leq I_{LOAD} \leq 3\text{A}$	11.52/11.40	12	12.48/12.60	V
Efficiency	η	$V_{IN}=15\text{V}, I_{LOAD}=3\text{A}$		90		%

S5ULM2596 Electrical Characteristics

Specifications with standard type face are for $T_J=25^\circ\text{C}$, and those with **boldface type** apply over **full operating temperature range**

Parameter	Symbol	Conditions	Min (Note4)	Typ (Note3)	Max (Note4)	Unit
System Parameters (Note5) Test Circuit Figure 2						
Output Voltage	V_{OUT}	$4.5 \leq V_{IN} \leq 40\text{V}, 0.2\text{A} \leq I_{LOAD} \leq 3\text{A}$ $V_{OUT}=3\text{V}$, Circuit of Figure 2	1.193/1.180	1.230	1.267/1.280	V
Efficiency	η	$V_{IN}=12\text{V}, I_{LOAD}=3\text{A}, V_{OUT}=3\text{V}$		77		%

All Output Voltage Version Electrical Characteristics

Specifications with standard type face are for $T_J=25^\circ\text{C}$, and those with **boldface type** apply over **full operating temperature range**.

Unless otherwise specified, $V_{IN}=12\text{V}$ for the 3.3V, 5.0V and Adjustable versions, $V_{IN}=24\text{V}$ for 12V version. $I_{LOAD}=0.5\text{A}$

Parameter	Symbol	Conditions	Min (Note4)	Typ (Note3)	Max (Note4)	Unit
Feedback bias current	I_b	$V_{FB}=1.3\text{V}$ (adjustable version only)	-	10	50/ 00	nA
Oscillator frequency	f_O	(Note 6)	127/110	150	173/173	kHz
Saturation voltage	V_{SAT}	$I_{LOAD}=3\text{A}$ (Note 7, 8)	-	1.16	1.4/1.5	V
Maximum duty cycle ^(ON) _(OFF)	DC	(Note 8) (Note 9)	-	100 0	-	%
Current limit	I_{CL}	Peak Current (Note 7, 8)	3.6/3.4	4.5	6.9/7.5	A
Output leakage current	I_L	Output=0V (Note 7, 9)	-	-	50	μA
		Output=-1V (Note 10)	-	2	30	mA
Quiescent current	I_Q	(Note 9)	-	5	10	mA
Standby quiescent current	I_{STBY}	ON/OFF pin=5V (OFF) (Note 10)	-	80	200/250	μA
Thermal Resistance	θ_{JC}	Junction to Case	-	2	-	$^\circ\text{C/W}$
	θ_{JA}	Junction to Ambient (Note 11)	-	50	-	
ON/OFF Control Test Circuit Figure 2						
ON/OFF pin logic input Threshold Voltage			-	1.3	-	V
	V_{IH}	Low (Regulator ON)		-	0.6	
	V_{IL}	High (Regulator OFF)	2.0	-	-	
ON/OFF pin input current	I_H	$V_{LOGIC}=2.5\text{V}$ (Regulator OFF)	-	5	15	μA
	I_L	$V_{LOGIC}=0.5\text{V}$ (Regulator ON)	-	0.02	5	

Note 1: Absolute Maximum Rating indicate limits beyond which damage to the device may occur. Operating Rating indicate conditions for which the device is intended to be functional, but do not guaranteed specific performance limits. For guaranteed specifications and test conditions, see the Electrical Characteristics.

Note 2: The human body mode is a 100pF capacitor discharged through a 1.5k Ω resistor into each pin.

Note 3: Typical number are at 25°C and represent the most likely norm.

Note 4: All limits guaranteed at room temperature (standard type face) and at temperature extremes (bold type face). All room temperature limits are 100% production tested. All limits at temperature extremes are guaranteed via correlation using standard Statistical Quality Control (SQC) method. All limits are used to calculate Average Outgoing Quality Level (AOQL).

Note 5: External component such as the catch diode, inductor, input and output capacitors, and voltage programming resistor can affect switching regulator system performance. When the G5ELM2596 is used as shutdown in the Figure 1 test circuit, system performance will be as shown in system parameters section of Electrical Characteristics.

Note 6: The switching frequency is reduced when the second stage current limit is activated. The amount of reduction is determined by the severity of current over-load.

Note 7: No diode, inductor or capacitor connected to output pin.

Note 8: Feedback pin removed from output and connected to 0V to force the output transistor switch ON.

Note 9: Feedback pin removed from output and connected to 12V for the Adjustable, 3.3V and 5V versions, and 15V for the 12V version, to force the output transistor switch OFF.

Note 10: $V_{IN}=40\text{V}$.

Note 11: Junction to ambient thermal resistance (no external heat sink) for To-220 package mounted vertically, with the leads soldered to a printed circuit board with (1 oz.) copper area of approximately 1 in².

Typical Performance Characteristics (circuit of Figure 2)

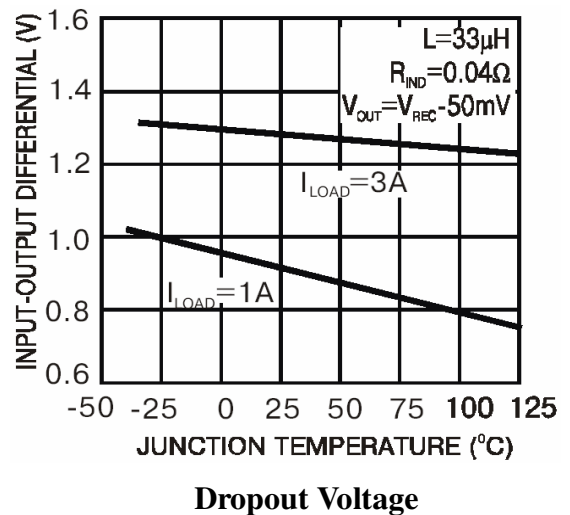
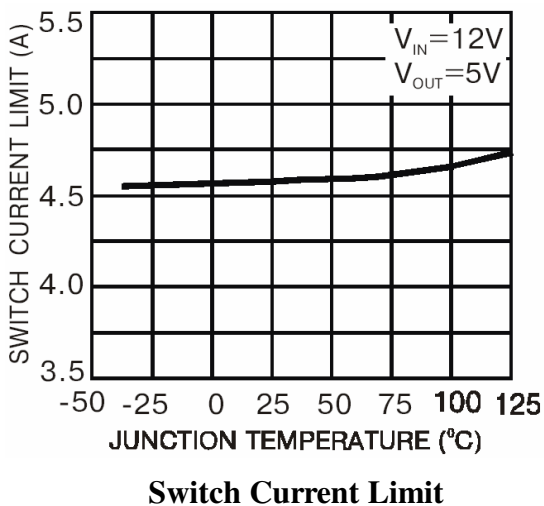
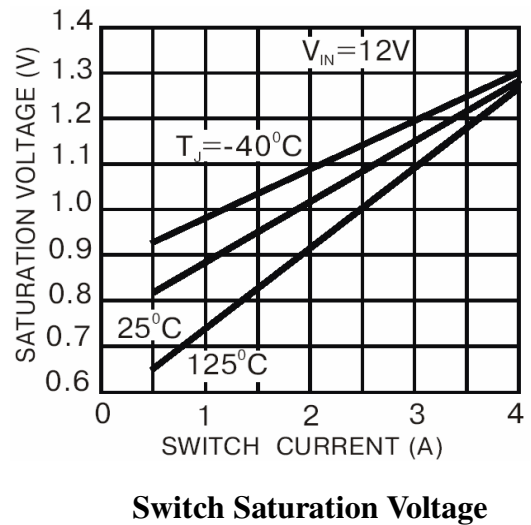
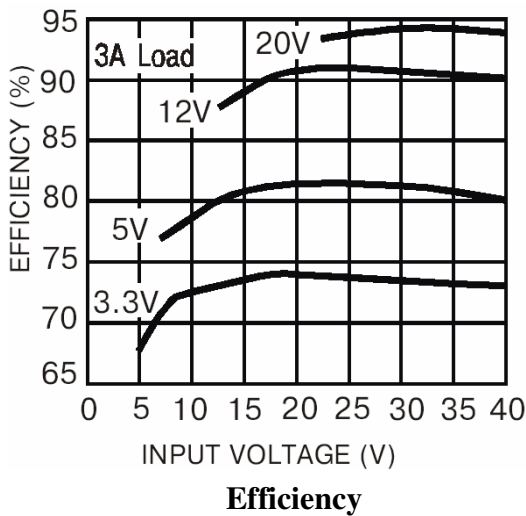
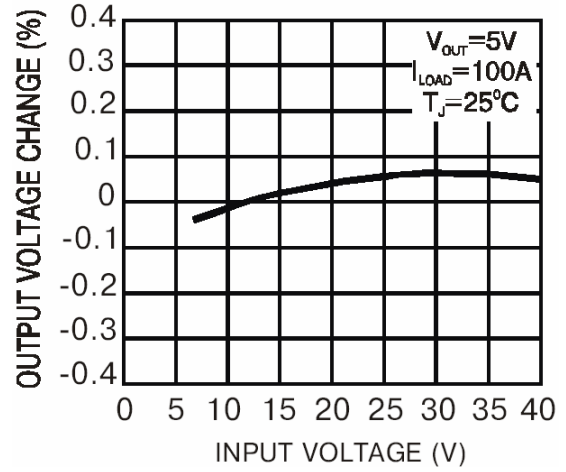
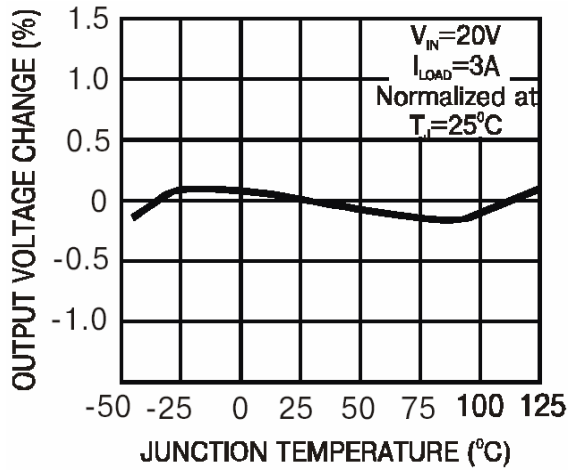

S5ULM2596

Simple Switcher Power Converter
150KHz 3A Step-Down Voltage Regulator

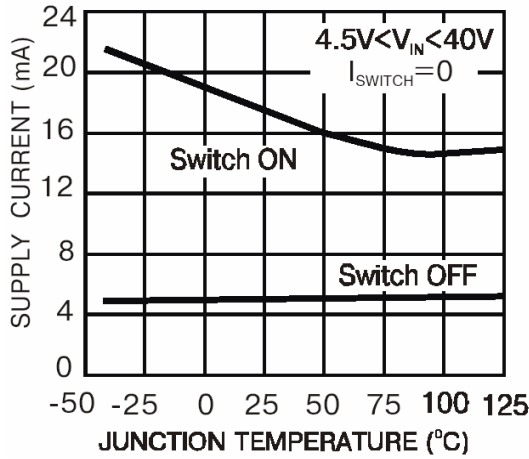

Operating Quiescent Current

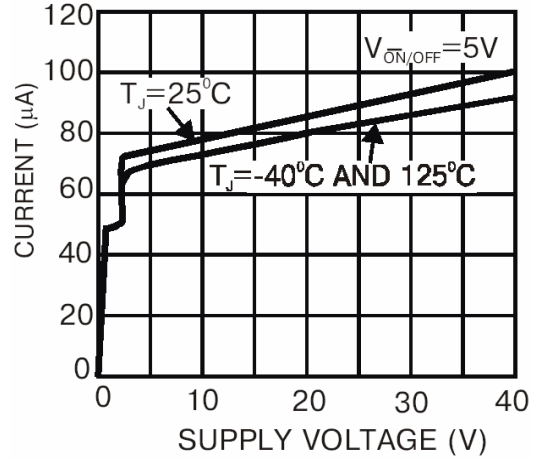

Shutdown Quiescent Current

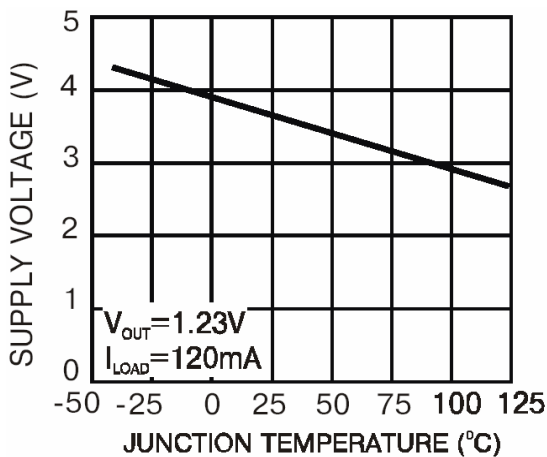

Minimum Operating Supply Voltage

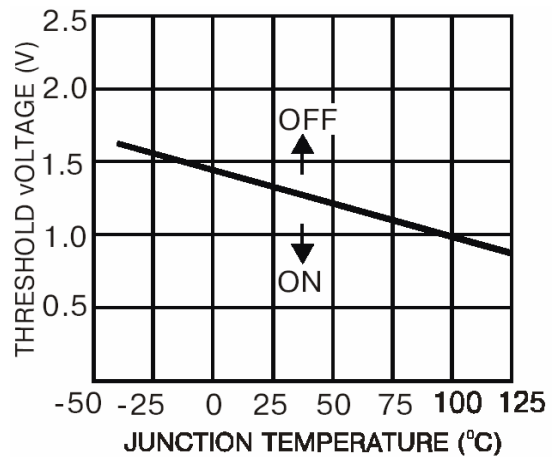

\overline{ON}/OFF Threshold Voltage

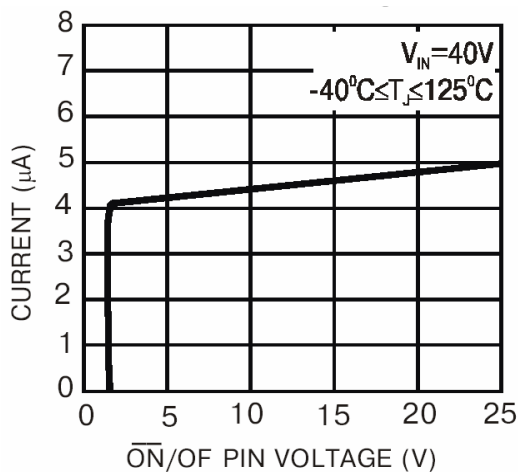

\overline{ON}/OFF Pin Current (Sinking)

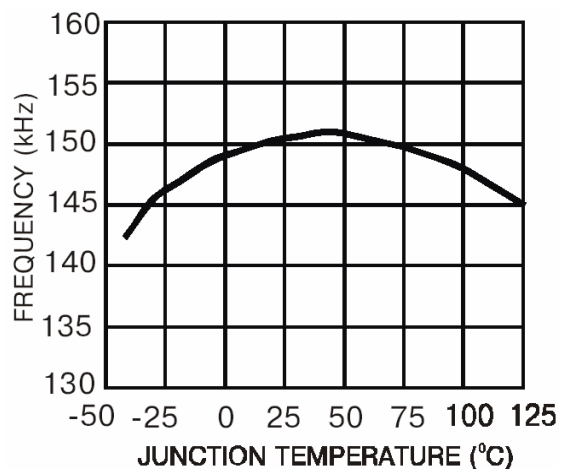

Switching Frequency

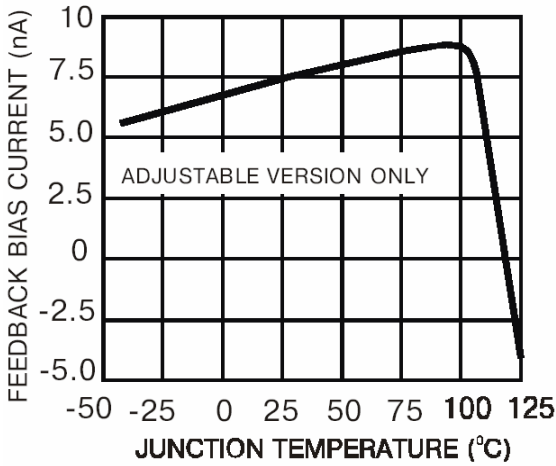

Feedback Pin Bi

$V_{IN}=20V, V_{OUT}=5V, I_{LOAD}=500mA$
 $L=10\mu H, C_{OUT}=330\mu F, C_{OUT}ESR=45m\Omega$

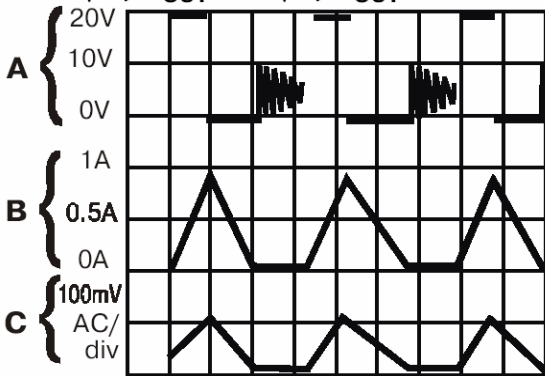

A: Output Pin Voltage, 10V/div
B: Inductor Current 1A/div
C: Output Ripple Voltage, 100mV/div

Horizontal Time Base: 2μs

Discontinuous Mode Switching Waveforms

$V_{IN}=20V, V_{OUT}=5V, I_{LOAD}=500mA \text{ to } 2A$
 $L=10\mu H, C_{OUT}=330\mu F, C_{OUT}ESR=45m\Omega$

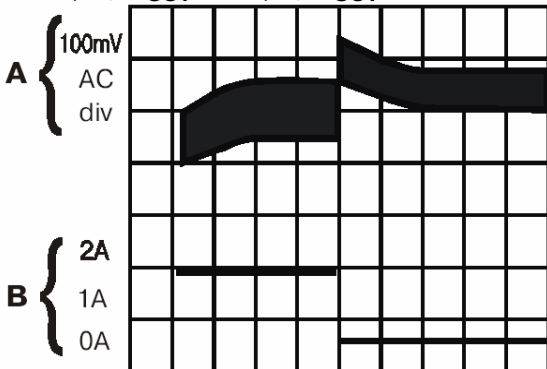

A: Output Voltage, 100mV/div. (AC)
B: 500mA to 2A Load Pulse

Horizontal Time Base: 200μs
Load Transient Response
for Discontinuous Mode

$V_{IN}=20V, V_{OUT}=5V, I_{LOAD}=2A$
 $L=32\mu H, C_{OUT}=220\mu F, C_{OUT}ESR=50m\Omega$

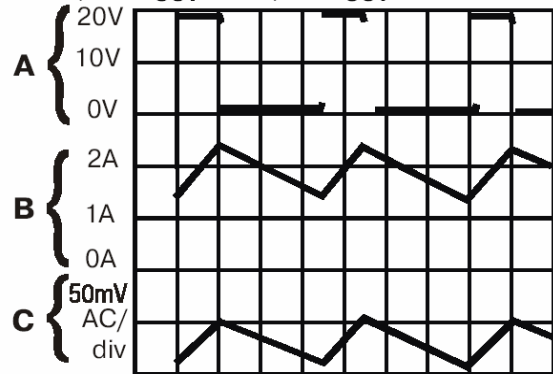

A: Output Pin Voltage, 10V/div
B: Inductor Current 1A/div
C: Output Ripple Voltage, 50mV/div

Horizontal Time Base: 2μs

Continuous Mode Switching Waveforms

$V_{IN}=20V, V_{OUT}=5V, I_{LOAD}=500mA \text{ to } 2A$
 $L=32\mu H, C_{OUT}=220\mu F, C_{OUT}ESR=50m\Omega$

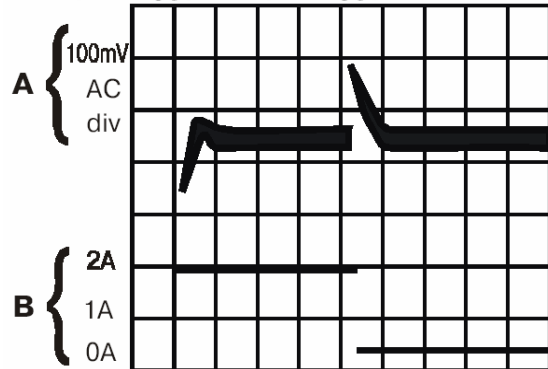

A: Output Voltage, 100mV/div. (AC)
B: 500mA to 2A Load Pulse

Horizontal Time Base: 100μs
Load Transient Response
for Continuous Mode

Test Circuit and layout Guidelines

As in any switching regulator, layout is very important. Rapidly switching currents associated with wiring inductance generate voltage transients which can cause problems. For minimal inductance and ground loops, the wires indicated by **heavy lines** should be **wide printed circuit traces and should be kept as short as possible**. For best results, external components should be located as close to the switcher IC as possible using ground plane construction or single point grounding.

If **open core inductors are used**, special care must be taken as to the location and positioning of this type of inductor. Allowing the inductor flux to intersect sensitive feedback, IC groundpath and C_{OUT} wiring can cause problems. When using the Adjustable version, special care must be taken as to the location of the feedback resistors and the associated wiring. Physically locate both resistors near the IC, and route the wiring away from the inductor, especially an open core type of inductor.

Fixed Output Voltage Versions

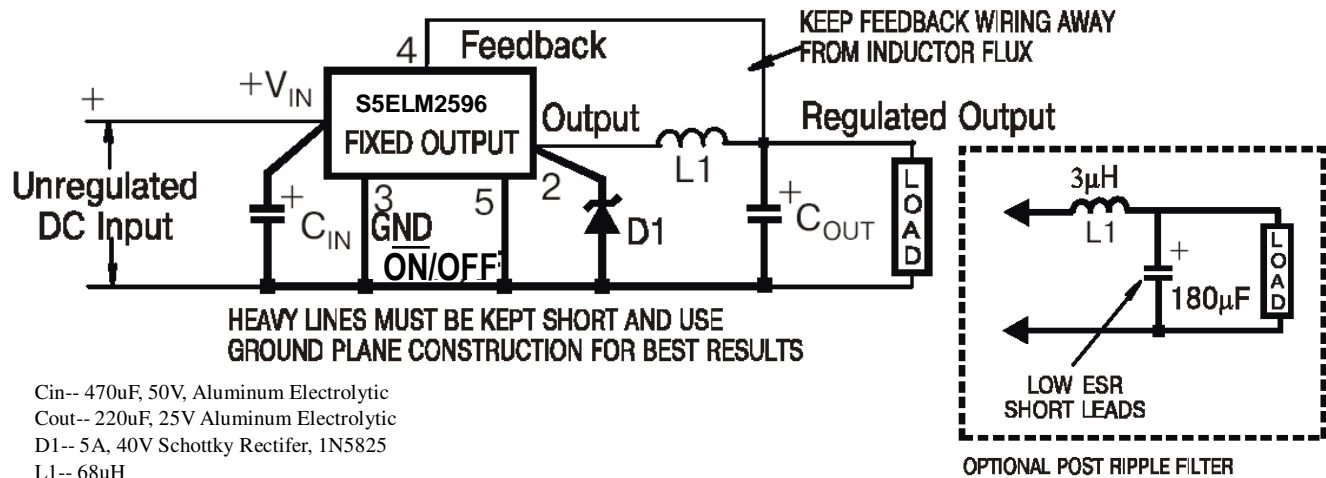

Adjustable Output Voltage Versions

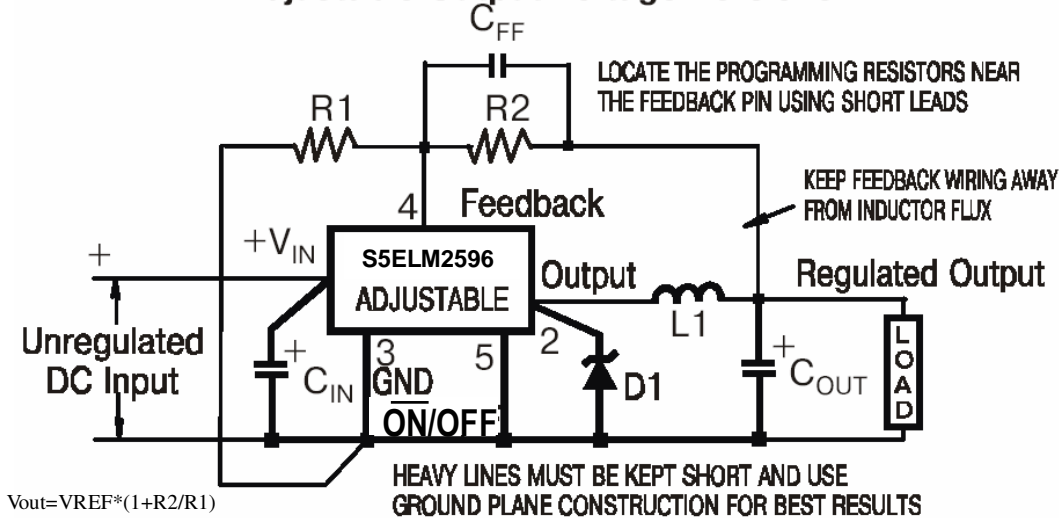

$$V_{out} = V_{REF} \cdot (1 + R2/R1)$$

Where $V_{REF} = 1.23V$

$$R2 = R1 \cdot (V_{out}/V_{REF} - 1)$$

Select R1 to be approximately 1kΩ, use a 1% resistor for best stability.

Cin-- 470µF, 50V, Aluminum Electrolytic

Cout-- 220µF, 35V Aluminum Electrolytic

D1-- 5A, 40V Schottky Rectifier, 1N5825

L1-- 68µH

Figure 2 Standard Test Circuits and Layout Guides