

# Photo IC for optical switch

S6841, S8119

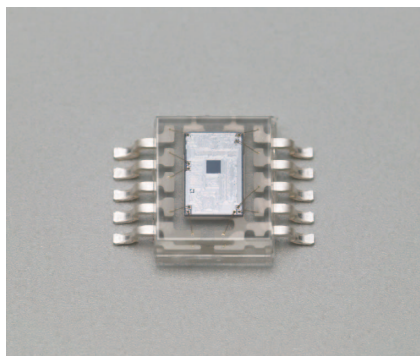

## Photo IC with optical switch functions

The S6841 and S8119 are specifically designed for optical switches. A transmission mode or reflection mode optical switch can be easily configured when used in combination with an LED.

### Features

- Miniature transparent plastic package (4.5 × 5.5 mm)
- Having following function at each terminal
  - Operation and margin display terminal
  - Synchronous/asynchronous switching terminal
  - Output logic switching terminal
- Built-in short-circuit protective circuit
- **S6841: High sensitivity (0.05 μW/mm<sup>2</sup> typ.)**  
**S8119: Large allowable background light level (10000 lx typ.)**

### Applications

- Optical switch

### Absolute maximum ratings (Ta=25 °C)

Parameter	Symbol	Value	Unit
Supply voltage	Vcc	-0.3 to +7	V
Power dissipation*1	P	250	mW
Output voltage	Terminal ②④⑤⑩ Vout	-0.3 to Vcc	V
Input voltage	Terminal ③⑧⑨ Vin	-0.3 to +6	
Operating temperature	Topr	-25 to +60	°C
Storage temperature	Tstg	-40 to +100	°C
Soldering	-	230 °C , 3 s	-

\*1: Power dissipation decreases at a rate of 3.3 mW/°C above Ta=25 °C

Note: Exceeding the absolute maximum ratings even momentarily may cause a drop in product quality. Always be sure to use the product within the absolute maximum ratings.

Electrical and optical characteristics (Ta=25 °C, Vcc=5 V, unless otherwise noted)

Parameter	Symbol	Condition	S6841			S8119			Unit	
			Min.	Typ.	Max.	Min.	Typ.	Max.		
Spectral response range	$\lambda$		-	380 to 1120	-	-	380 to 1120	-	nm	
Peak sensitivity wavelength	$\lambda_p$		-	820	-	-	820	-	nm	
Supply voltage	Vcc		4.5	5.0	5.5	4.5	5.0	5.5	V	
Current consumption	Icc	OUT · LED terminals open	-	5.0	7.0	-	5.0	7.0	mA	
OUT terminal output current	ON	Ion	SOURCE, Vout=2.5 V	60	-	-	60	-	-	$\mu$ A
	OFF	Iof	SOURCE, Vout=0 V	-	-	1.0	-	-	1.0	$\mu$ A
LED terminal output	Current (LED is on)	Iledn	SOURCE, Vled=2.5 V	570	650	725	570	650	725	$\mu$ A
	Current (LED is off)	Iledf	SOURCE, Vled=0 V	-	-	10	-	-	10	$\mu$ A
	Pulse cycle	Tp1	*2	112	160	208	112	160	208	$\mu$ s
	Pulse width	Tw1		3.5	5	6.5	3.5	5	6.5	$\mu$ s
Signal light (in asynchronous mode)	Pulse cycle	Tp2		60	-	100	60	-	100	$\mu$ s
	Pulse width	Tw2		4	-	6	4	-	6	$\mu$ s
DSP terminal output current	Idsp	SINK, Vdsp=1.0 V	0.8	-	1.6	0.8	-	1.6	mA	
MRG terminal	Setup level	M		-	200	-	-	200	-	%
	Output current	Imrg	SINK, Vmrg=1.0 V	2.0	-	3.6	2.0	-	3.6	mA
SW terminal	Input L current	Iswl	SOURCE, Vsw=0 V	-	-	100	-	-	100	$\mu$ A
	Input H current	Iswh	SINK, Vsw=5 V	-	-	100	-	-	100	$\mu$ A
	Input H voltage	Vswh		2	-	-	2	-	-	V
	Input L voltage	Vswl		-	-	0.8	-	-	0.8	V
INV terminal	Input L current	Iinvl	SOURCE, Vinv=0 V	-	-	100	-	-	100	$\mu$ A
	Input H current	Iinvh	SINK, Vinv=5 V	-	-	100	-	-	100	$\mu$ A
	Input H voltage	Vinvh		2	-	-	2	-	-	V
	Input L voltage	Vinvl		-	-	0.8	-	-	0.8	V
Threshold light level	Eep	No background light $\lambda=850$ nm	-	0.05	0.1	-	0.1	0.2	$\mu$ W/mm <sup>2</sup>	
Hysteresis	Hys		0.7	0.8	0.9	0.7	0.8	0.9	-	
Allowable background light level	Ex	*3	3500	5000	-	6000	10000	-	Lx	
Propagation delay time	Synchronous	Tpd1on	*4 Shield to input	-	-	1100	-	650	900	$\mu$ s
		Tpd1of	*4 Input to shield	-	-	1100	-	650	900	$\mu$ s
	Asynchronous	Tpd2on	Shield to input	-	-	1200	-	-	1000	$\mu$ s
		Tpd2of	Input to shield	-	-	1300	-	-	1300	$\mu$ s
Input signal level	Eepp	*5	-	-	1				$\mu$ W/mm <sup>2</sup>	

\*2: Pulse cycle, pulse width: See below.

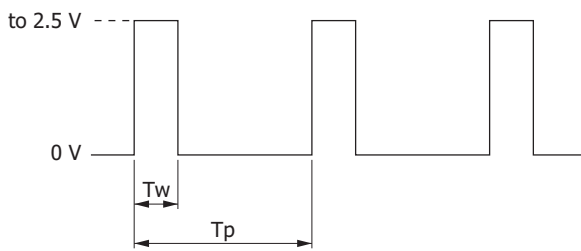

LED terminal output waveform

KPIC0060EA

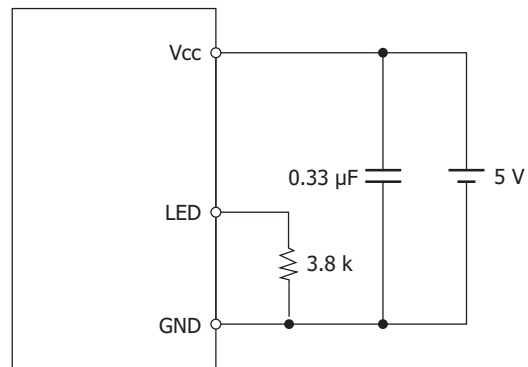

Measurement circuit

KPIC0061EA

\*3: Allowable background light level

This is defined as the background light level on the photosensitive area at which the photo IC sensitivity\* drops by 20%.

\* Sensitivity is the reciprocal of light level, which is constantly detected as a signal.

If background disturbance light strikes a part on the package (other than the active area) of the S6841, this may lower the allowable background light level. Use light-impervious tape to provide light-shielding over the shaded area of the package as shown below. Light-shielding is unnecessary for the S8119.

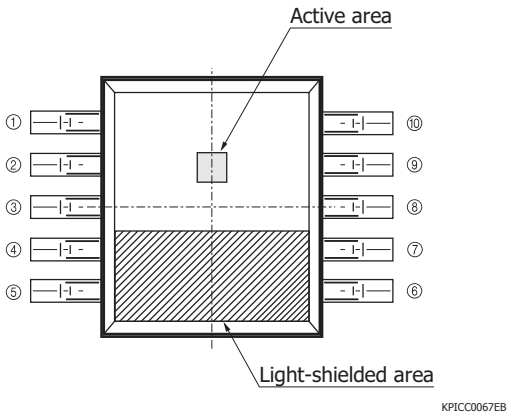

Light-shielded area (S6841)

\*4: H→L, L→H propagation delay time

The optical system is adjusted so that the Vo terminal output becomes "Low" voltage when the switch shown in the circuit below is off. (The S6841 is then measured with a signal light input of 1 μW/mm<sup>2</sup> illuminance.)

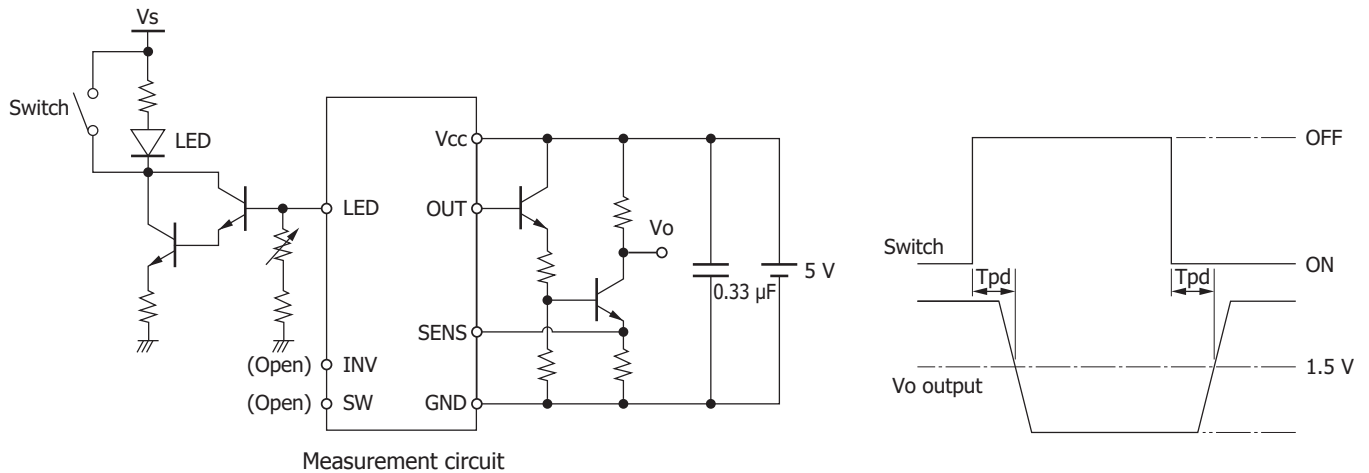

KPIC0062EB

\*5: This is the input signal light level for the propagation delay time to stay within specifications.

If the input signal light exceeds this level, the propagation delay time may increase.

**Block diagram**

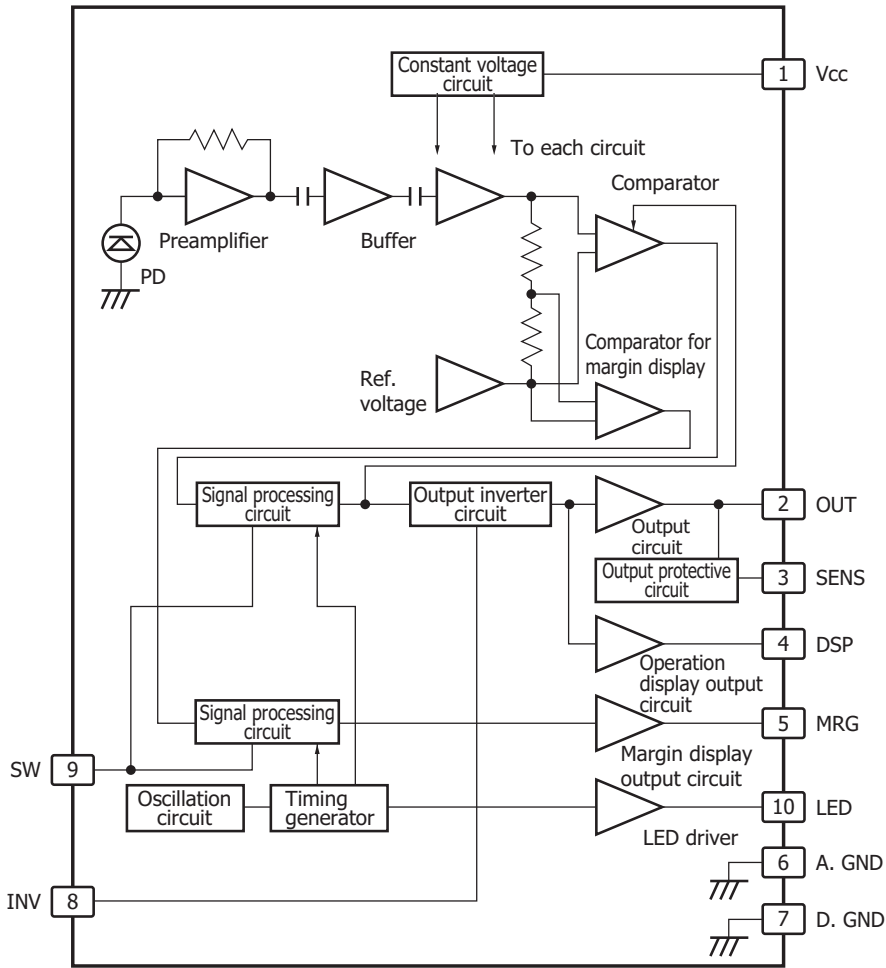

KP1CC0048EB

**Truth table**

INV terminal: High

Input	OUT output	DSP output	MRG output
Light ON	ON	ON	ON
Light OFF	OFF	OFF	OFF

INV terminal: Low

Input	OUT output	DSP output	MRG output
Light ON	OFF	OFF	ON
Light OFF	ON	ON	OFF

SW terminal	Detection Method
High	Synchronous
Low	Asynchronous

**Terminal configuration**

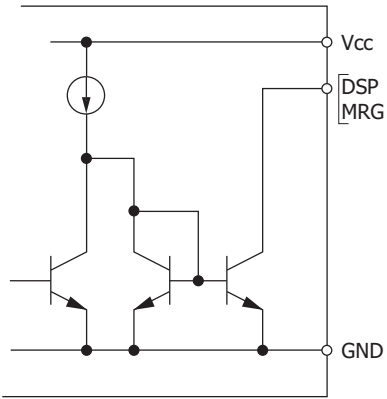

Operation display terminal  
Margin display terminal

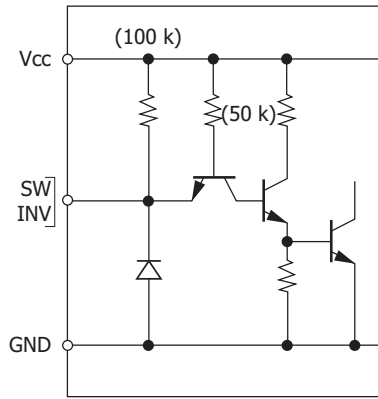

Detection method switching terminal  
Output switching terminal

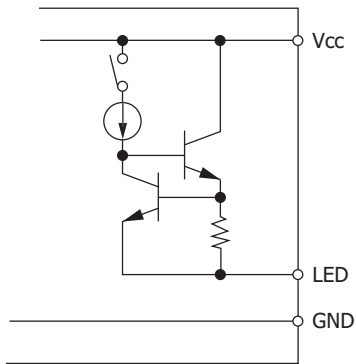

LED terminal

KP1CC0063EB

**OUT terminal and SENS terminal configurations and recommended external short-circuit protective circuit**

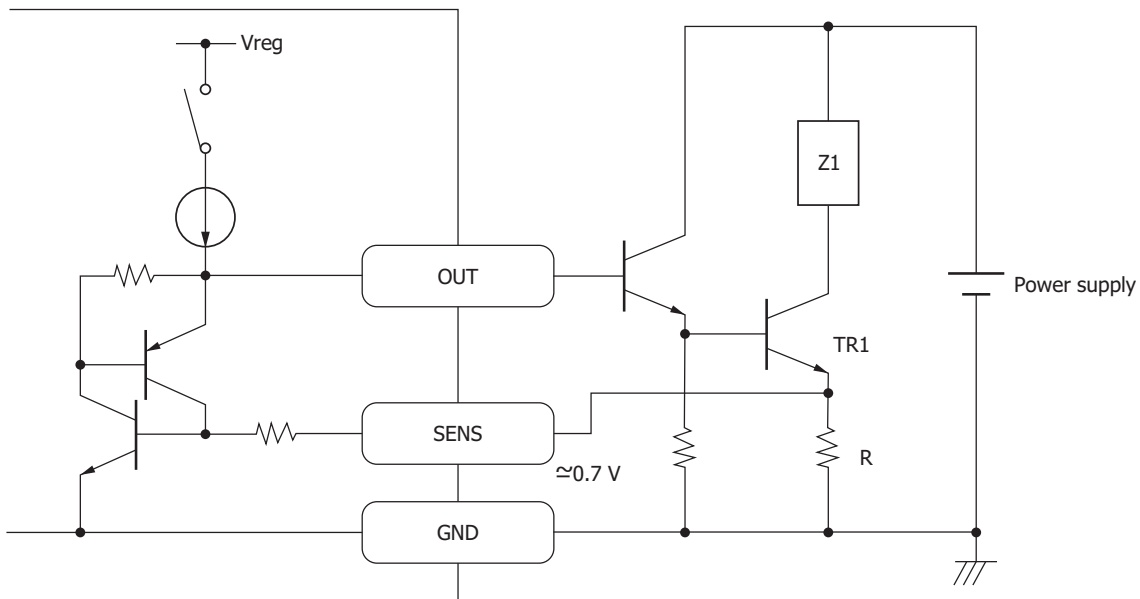

KP1CC0064EB

Dimensional outline (unit: mm)

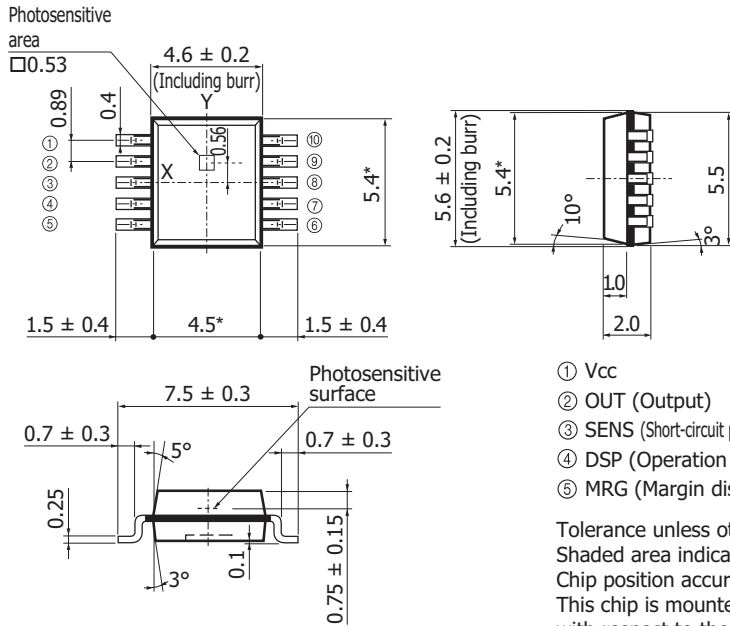

- ① Vcc
- ② OUT (Output)
- ③ SENS (Short-circuit protective input for output terminal load)
- ④ DSP (Operation display)
- ⑤ MRG (Margin display)
- ⑥ A. GND
- ⑦ D. GND
- ⑧ INV (Output logic switching)
- ⑨ SW (Synchronous, asynchronous switching)
- ⑩ LED

Tolerance unless otherwise noted: ±0.1, ±2°  
 Shaded area indicates burr.  
 Chip position accuracy  
 This chip is mounted with the following accuracy with respect to the package dimensions marked \*  
 X, Y ≤ ±0.2

KPICA0020EC

Related information

[www.hamamatsu.com/sp/ssd/doc\\_en.html](http://www.hamamatsu.com/sp/ssd/doc_en.html)

Precautions

- Disclaimer
- Metal, ceramic, plastic products

Information described in this material is current as of October 2017.

Product specifications are subject to change without prior notice due to improvements or other reasons. This document has been carefully prepared and the information contained is believed to be accurate. In rare cases, however, there may be inaccuracies such as text errors. Before using these products, always contact us for the delivery specification sheet to check the latest specifications.

The product warranty is valid for one year after delivery and is limited to product repair or replacement for defects discovered and reported to us within that one year period. However, even if within the warranty period we accept absolutely no liability for any loss caused by natural disasters or improper product use. Copying or reprinting the contents described in this material in whole or in part is prohibited without our prior permission.

**HAMAMATSU**

[www.hamamatsu.com](http://www.hamamatsu.com)

HAMAMATSU PHOTONICS K.K., Solid State Division

1126-1 Ichino-cho, Higashi-ku, Hamamatsu City, 435-8558 Japan, Telephone: (81) 53-434-3311, Fax: (81) 53-434-5184

U.S.A.: Hamamatsu Corporation: 360 Foothill Road, Bridgewater, N.J. 08807, U.S.A., Telephone: (1) 908-231-0960, Fax: (1) 908-231-1218, E-mail: [usa@hamamatsu.com](mailto:usa@hamamatsu.com)  
 Germany: Hamamatsu Photonics Deutschland GmbH: Arzbergerstr. 10, D-82211 Herrsching am Ammersee, Germany, Telephone: (49) 8152-375-0, Fax: (49) 8152-265-8, E-mail: [info@hamamatsu.de](mailto:info@hamamatsu.de)  
 France: Hamamatsu Photonics France S.A.R.L.: 19, Rue du Saule Trapu, Parc du Moulin de Massy, 91882 Massy Cedex, France, Telephone: 33-(1) 69 53 71 00, Fax: 33-(1) 69 53 71 10, E-mail: [infos@hamamatsu.fr](mailto:infos@hamamatsu.fr)  
 United Kingdom: Hamamatsu Photonics UK Limited: 2 Howard Court, 10 Tewin Road, Welwyn Garden City, Hertfordshire AL7 1BW, United Kingdom, Telephone: (44) 1707-294888, Fax: (44) 1707-325777, E-mail: [info@hamamatsu.co.uk](mailto:info@hamamatsu.co.uk)  
 North Europe: Hamamatsu Photonics Norden AB: Torshamnsgatan 35 16440 Kista, Sweden, Telephone: (46)8-509 031 00, Fax: (46)8-509 031 01, E-mail: [info@hamamatsu.se](mailto:info@hamamatsu.se)  
 Italy: Hamamatsu Photonics Italia S.r.l.: Strada della Moia, 1 int. 6, 20020 Arese (Milano), Italy, Telephone: (39)02-93 58 17 33, Fax: (39)02-93 58 17 41, E-mail: [info@hamamatsu.it](mailto:info@hamamatsu.it)  
 China: Hamamatsu Photonics (China) Co., Ltd.: B1201, Jiaming Center, No.27 Dongsanhuan Beilu, Chaoyang District, Beijing 100020, China, Telephone: (86) 10-6586-6006, Fax: (86) 10-6586-2866, E-mail: [hpc@hamamatsu.com.cn](mailto:hpc@hamamatsu.com.cn)  
 Taiwan: Hamamatsu Photonics Taiwan Co., Ltd.: 8F-3, No. 158, Section2, Gongdao 5th Road, East District, Hsinchu, 300, Taiwan R.O.C. Telephone: (886)03-659-0080, Fax: (886)03-659-0081, E-mail: [info@tw.hpk.co.jp](mailto:info@tw.hpk.co.jp)