

4Mb Async. FAST SRAM A-die Specification

NETSOL RESERVES THE RIGHT TO CHANGE PRODUCTS, INFORMATION AND SPECIFICATIONS WITHOUT NOTICE.

Products and specifications discussed herein are for reference purposes only. All information discussed herein is provided on an "AS IS" basis, without warranties of any kind.

This document and all information discussed herein remain the sole and exclusive property of NETSOL. No license of any patent, copyright, mask work, trademark or any other intellectual property right is granted by one party to the other party under this document, by implication, estoppel or otherwise.

For updates or additional information about Netsol products, please contact to netsol@netsol.co.kr

Document Title

256Kx16 & 512Kx8 Bit Asynchronous FAST SRAM

Revision History

Rev. No.	History	Draft Date	Remark
0.0	Initial Draft	Mar. 2013	Preliminary
1.0	Final spec release	Jul. 2013	Final
1.1	Add wide Vcc range support 1.65 ~ 3.6V Add 48FBGA and 36FBGA PKG information	Aug. 2013	Final
1.2	Add 12ns speed binning Change ordering information table format Remove the ordering information of -UC(I)15, -XC(I)15, -NC(I)15	Nov. 2013	Final

S6R4016V1A, S6R4016C1A, S6R4016W1A S6R4008V1A, S6R4008C1A, S6R4008W1A

4M Async FAST SRAM

256Kx16 & 512Kx8 Bit Asynchronous FAST SRAM

Features

- Fast Access Time 8, 10, 12, 15ns(Max)
- CMOS Low Power Dissipation
Standby (TTL) : 10mA (Max.)
(CMOS) : 6mA (Max.)
Operating : 35mA (8ns, Max.)
30mA (10ns, Max.)
- Single 3.3±0.3V or 5.0±0.5V Power Supply
- S6R40xxV1A : 3.3±0.3V Power Supply
- S6R40xxC1A : 5.0±0.5V Power Supply
- Wide range of Power Supply
- S6R40xxW1A : 1.65V ~ 3.6V Power Supply
- TTL Compatible Inputs and Outputs
- Fully Static Operation, No Clock or Refresh required
- Three State Outputs
- Data Byte Control(x16 Mode)
LB : I/O0~ I/O7, UB : I/O8~ I/O15
- Standard 44TSOP2, 36FBGA and 48FBGA Package Pin Configuration
- Operating in Commercial and Industrial Temperature range.

General Description

The S6R4016(V/C/W)1A and S6R4008(V/C/W)1A are a 4,194,304-bit high-speed Static Random Access Memory organized as 256K (512K) words by 16(8) bits. The S6R4016(V/C/W)1A (S6R4008(V/C/W)1A) uses 16(8) common input and output lines and have an output enable pin which operates faster than address access time at read cycle. And S6R4016(V/C/W)1A allows that lower and upper byte access by data byte control(\overline{UB} , \overline{LB}). The device is fabricated using advanced CMOS process, 6-TR based cell technology and designed for high-speed circuit technology. It is particularly well suited for use in high-density high-speed system applications.

The S6R4016(V/W)1A is packaged in a 400mil 44-pin TSOP2 and 48FBGA.

The S6R4016C1A is packaged in a 400mil 44-pin TSOP2.

The S6R4008(V/W)1A is packaged in a 400mil 44-pin TSOP2 and 36FBGA.

The S6R4008C1A is packaged in a 400mil 44-pin TSOP2.

4Mb Asynchronous FAST SRAM Ordering Information (256Kx16)

Density	Org.	Part Number	Vcc (V)	Speed		Package	TEMP
				tAA(ns)	tOE(ns)		
4Mb	256Kx16	S6R4016V1A-UC(I)08	3.3	8	4	44 TSOP2	C : Commercial Temperature I : Industrial Temperature
		S6R4016W1A-UC(I)08	3.3	8	4	44 TSOP2	
		S6R4016W1A-UC(I)08	2.5	10	5	44 TSOP2	
		S6R4016W1A-UC(I)08	1.8	12	6	44 TSOP2	
		S6R4016V1A-XC(I)08	3.3	8	4	48 FBGA	
		S6R4016W1A-XC(I)08	3.3	8	4	48 FBGA	
		S6R4016W1A-XC(I)08	2.5	10	5	48 FBGA	
		S6R4016W1A-XC(I)08	1.8	12	6	48 FBGA	
		S6R4016C1A-UC(I)10	5.0	10	5	44 TSOP2	
		S6R4016V1A-UC(I)10	3.3	10	5	44 TSOP2	
		S6R4016W1A-UC(I)10	3.3	10	5	44 TSOP2	
		S6R4016W1A-UC(I)10	2.5	10	5	44 TSOP2	
		S6R4016W1A-UC(I)10	1.8	15	7	44 TSOP2	
		S6R4016V1A-XC(I)10	3.3	10	5	48 FBGA	
		S6R4016W1A-XC(I)10	3.3	10	5	48 FBGA	
		S6R4016W1A-XC(I)10	2.5	10	5	48 FBGA	
S6R4016W1A-XC(I)10	1.8	15	7	48 FBGA			

**S6R4016V1A, S6R4016C1A, S6R4016W1A
S6R4008V1A, S6R4008C1A, S6R4008W1A**

4M Async FAST SRAM

4Mb Asynchronous FAST SRAM Ordering Information (512Kx8)

Density	Org.	Part Number	Vcc (V)	Speed		Package	TEMP
				tAA(ns)	tOE(ns)		
4Mb	512Kx8	S6R4008V1A-UC(I)08	3.3	8	4	44 TSOP2	C : Commercial Temperature I : Industrial Temperature
		S6R4008W1A-UC(I)08	3.3	8	4	44 TSOP2	
		S6R4008W1A-UC(I)08	2.5	10	5	44 TSOP2	
		S6R4008W1A-UC(I)08	1.8	12	6	44 TSOP2	
		S6R4008V1A-NC(I)08	3.3	8	4	36 FBGA	
		S6R4008W1A-NC(I)08	3.3	8	4	36 FBGA	
		S6R4008W1A-NC(I)08	2.5	10	5	36 FBGA	
		S6R4008W1A-NC(I)08	1.8	12	6	36 FBGA	
		S6R4008C1A-UC(I)10	5.0	10	5	44 TSOP2	
		S6R4008V1A-UC(I)10	3.3	10	5	44 TSOP2	
		S6R4008W1A-UC(I)10	3.3	10	5	44 TSOP2	
		S6R4008W1A-UC(I)10	2.5	10	5	44 TSOP2	
		S6R4008W1A-UC(I)10	1.8	15	7	44 TSOP2	
		S6R4008V1A-NC(I)10	3.3	10	5	36 FBGA	
		S6R4008W1A-NC(I)10	3.3	10	5	36 FBGA	
		S6R4008W1A-NC(I)10	2.5	10	5	36 FBGA	
S6R4008W1A-NC(I)10	1.8	15	7	36 FBGA			

**S6R4016V1A, S6R4016C1A, S6R4016W1A
S6R4008V1A, S6R4008C1A, S6R4008W1A**

4M Async FAST SRAM

Logic Block Diagram - S6R4016(V/C/W)1A (256K x 16)

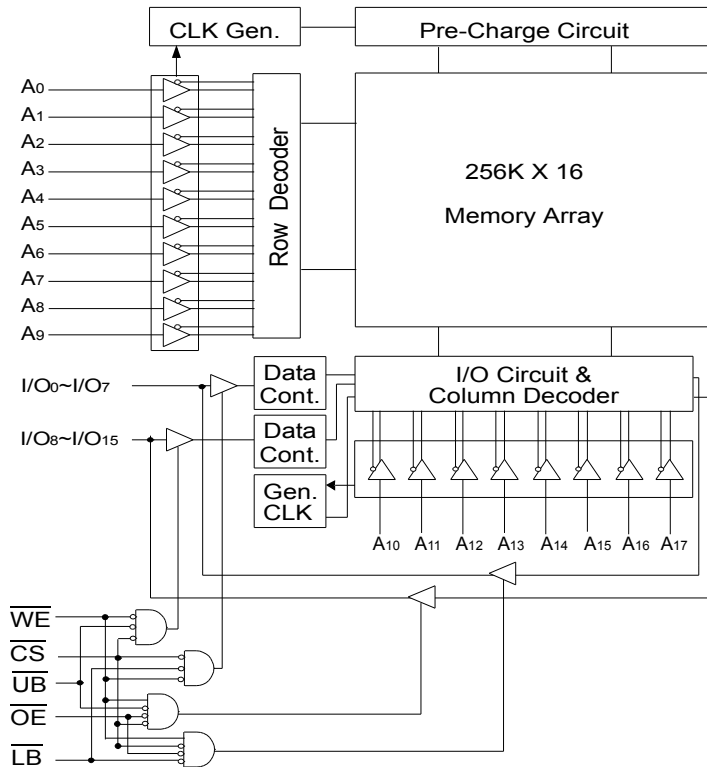

Logic Block Diagram - S6R4008(V/C/W)1A (512K x 8)

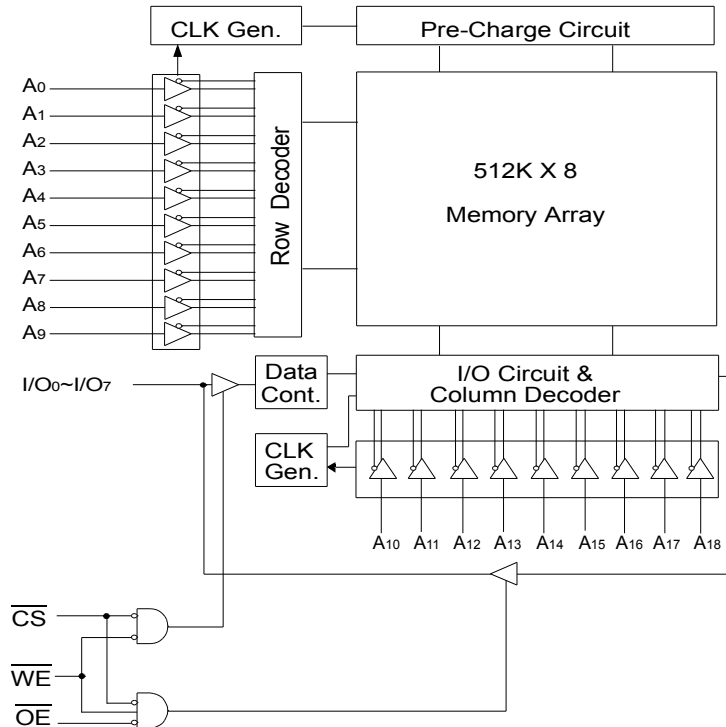

**S6R4016V1A, S6R4016C1A, S6R4016W1A
S6R4008V1A, S6R4008C1A, S6R4008W1A**

4M Async FAST SRAM

44 TSOP2 Package Pin Configurations(Top View) - S6R4016(V/C/W)1A (256K x 16)

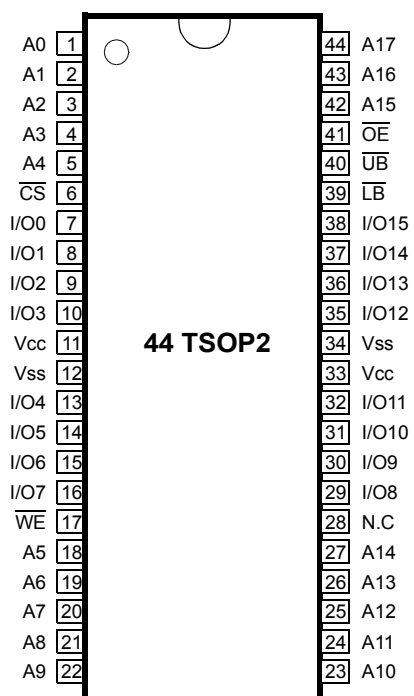

Pin Function

Pin Name	Pin Function
A0 - A17	Address Inputs
\overline{WE}	Write Enable
\overline{CS}	Chip Select
\overline{OE}	Output Enable
\overline{LB}	Lower-byte Control(I/O0~I/O7)
\overline{UB}	Upper-byte Control(I/O8~I/O15)
I/O0 ~ I/O15	Data Inputs/Outputs
Vcc	Power
Vss	Ground
N.C	No Connection

48FBGA - S6R4016(V/W)1A, 256Kx16 - Top View

PKG Pin Configurations

	1	2	3	4	5	6
A	\overline{LB}	\overline{OE}	A ₀	A ₁	A ₂	NC
B	I/O ₈	\overline{UB}	A ₃	A ₄	\overline{CS}	I/O ₀
C	I/O ₉	I/O ₁₀	A ₅	A ₆	I/O ₁	I/O ₂
D	Vss	I/O ₁₁	A ₁₇	A ₇	I/O ₃	Vcc
E	Vcc	I/O ₁₂	NC	A ₁₆	I/O ₄	Vss
F	I/O ₁₄	I/O ₁₃	A ₁₄	A ₁₅	I/O ₅	I/O ₆
G	I/O ₁₅	NC	A ₁₂	A ₁₃	\overline{WE}	I/O ₇
H	NC	A ₈	A ₉	A ₁₀	A ₁₁	NC

Pin Function

Pin Name	Pin Function
A0 - A17	Address Inputs
\overline{WE}	Write Enable
\overline{CS}	Chip Select
\overline{OE}	Output Enable
\overline{LB}	Lower-byte Control(I/O0~I/O7)
\overline{UB}	Upper-byte Control(I/O8~I/O15)
I/O0 ~ I/O15	Data Inputs/Outputs
Vcc	Power
Vss	Ground
NC	No Connection

**S6R4016V1A, S6R4016C1A, S6R4016W1A
S6R4008V1A, S6R4008C1A, S6R4008W1A**

4M Async FAST SRAM

44 TSOP2 Package Pin Configurations (Top View) - S6R4008(V/C/W)1A (512K x 8)

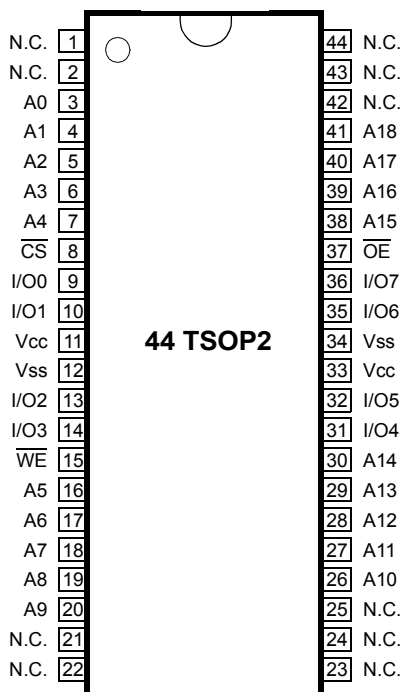

Pin Function

Pin Name	Pin Function
A0 - A18	Address Inputs
\overline{WE}	Write Enable
\overline{CS}	Chip Select
\overline{OE}	Output Enable
I/O0 ~ I/O7	Data Inputs/Outputs
Vcc	Power
Vss	Ground
N.C	No Connection

36FBGA - S6R4008(V/W)1A, 512Kx8 - Top View

PKG Pin Configurations

	1	2	3	4	5	6
A	A ₀	A ₁	NC	A ₃	A ₆	A ₈
B	I/O ₄	A ₂	\overline{WE}	A ₄	A ₇	I/O ₀
C	I/O ₅		NC	A ₅		I/O ₁
D	Vss					Vcc
E	Vcc					Vss
F	I/O ₆		A ₁₈	A ₁₇		I/O ₂
G	I/O ₇	\overline{OE}	\overline{CS}	A ₁₆	A ₁₅	I/O ₃
H	A ₉	A ₁₀	A ₁₁	A ₁₂	A ₁₃	A ₁₄

Pin Function

Pin Name	Pin Function
A0 - A18	Address Inputs
\overline{WE}	Write Enable
\overline{CS}	Chip Select
\overline{OE}	Output Enable
I/O0 ~ I/O7	Data Inputs/Outputs
Vcc	Power
Vss	Ground
NC	No Connection

**S6R4016V1A, S6R4016C1A, S6R4016W1A
S6R4008V1A, S6R4008C1A, S6R4008W1A**

4M Async FAST SRAM

Absolute Maximum Ratings*

Parameter		Symbol	Rating	Unit
Voltage on Any Pin Relative to VSS	3.3V Product	V _{IN} , V _{OUT}	-0.5 to V _{CC} +0.5V	V
	5.0V Product			
	Wide V _{CC} ** Product			
Voltage on V _{CC} Supply Relative to VSS	3.3V Product	V _{IN} , V _{OUT}	-0.5 to 4.6	V
	5.0V Product		-0.5 to 7.0	
	Wide V _{CC} ** Product		-0.5 to 4.6	
Power Dissipation		P _D	1.0	W
Storage Temperature		T _{STG}	-65 to 150	°C
Operating Temperature	Commercial	T _A	0 to 70	°C
	Industrial	T _A	-40 to 85	°C

* Stresses greater than those listed under "Absolute Maximum Ratings" may cause permanent damage to the device. This is a stress rating only and functional operation of the device at these or any other conditions above those indicated in the operating sections of this specification is not implied. Exposure to absolute maximum rating conditions for extended periods may affect reliability.

** Wide V_{CC} Range is 1.65V ~ 3.6V

Recommended DC Operating Conditions* (T_A=0 to 70°C)

Parameter	Operating V _{CC} (V)	Symbol	Min	Typ	Max	Unit
Supply Voltage	5.0	V _{CC}	4.5	5.0	5.5	V
	3.3	V _{CC}	3.0	3.3	3.6	
	Wide 2.4 ~ 3.6	V _{CC}	2.4	2.5/3.3	3.6	
	Wide 1.65 ~ 2.2	V _{CC}	1.65	1.8	2.2	
Ground		V _{SS}	0	0	0	V
Input High Voltage	5.0	V _{IH}	2.2	-	V _{CC} +0.5	V
	3.3	V _{IH}	2.0	-	V _{CC} +0.5	
	Wide 2.4 ~ 3.6	V _{IH}	2.0	-	V _{CC} +0.3	
	Wide 1.65 ~ 2.2	V _{IH}	1.4	-	V _{CC} +0.2	
Input Low Voltage	5.0	V _{IL}	-0.3	-	0.8	V
	3.3	V _{IL}	-0.3	-	0.8	
	Wide 2.4 ~ 3.6	V _{IL}	-0.3	-	0.7	
	Wide 1.65 ~ 2.2	V _{IL}	-0.2	-	0.4	

* The above parameters are also guaranteed for industrial temperature range.

**S6R4016V1A, S6R4016C1A, S6R4016W1A
S6R4008V1A, S6R4008C1A, S6R4008W1A**

4M Async FAST SRAM

DC and Operating Characteristics*(TA=0 to 70°C)

Parameter	Symbol	Test Conditions	Min	Max	Unit	
Input Leakage Current	ILI	VIN=Vss to Vcc	-2	2	μA	
Output Leakage Current	ILO	$\overline{CS}=V_{IH}$ or $\overline{OE}=V_{IH}$ or $\overline{WE}=V_{IL}$ VOUT=Vss to Vcc	-2	2	μA	
Operating Current**	ICC	Min. Cycle, 100% Duty CS=VIL, VIN=VIH or VIL, IOU=0mA	8ns	-	35	mA
			10ns	-	30	
			12ns		28	
			15ns		25	
Standby Current	ISB	Min. Cycle, $\overline{CS}=V_{IH}$	-	10	mA	
	ISB1	f=0MHz, $\overline{CS} \geq V_{CC}-0.2V$, VIN ≥ VCC-0.2V or VIN ≤ 0.2V	-	6		
Output Low Voltage Level	VOL	Vcc=4.5V, IOL=8mA, 5.0V Product	-	0.4	V	
		Vcc=3.0V, IOL=8mA, 3.3V Product & Wide Vcc** Product	-	0.4		
		Vcc=2.4V, IOL=1mA, Wide Vcc** Product	-	0.4		
		Vcc=1.65V, IOL=0.1mA, Wide Vcc** Product	-	0.2		
Output High Voltage Level	VOH	Vcc=4.5V, IOH=-4mA, 5.0V Product	2.4	-	V	
		Vcc=3.0V, IOH=-4mA, 3.3V Product & Wide Vcc** Product	2.4	-		
		Vcc=2.4V, IOH=-1mA, Wide Vcc** Product	1.8	-		
		Vcc=1.65V, IOH=-0.1mA, Wide Vcc** Product	1.4	-		

* The above parameters are also guaranteed for industrial temperature range.

** Wide Vcc Range is 1.65V ~ 3.6V

Capacitance*(TA=25°C, f=1.0MHz)

Item	Symbol	Test Conditions	TYP	Max	Unit
Input/Output Capacitance	CIO	VIO=0V	-	8	pF
Input Capacitance	CIN	VIN=0V	-	6	pF

* Capacitance is sampled and not 100% tested.

S6R4016V1A, S6R4016C1A, S6R4016W1A S6R4008V1A, S6R4008C1A, S6R4008W1A

4M Async FAST SRAM

Test Conditions*

Parameter	Value
Input Pulse Level	0 to 3.0V (Vcc=3.3V or 5.0V)
	0 to 2.5V (Vcc=2.5V)
	0 to 1.8V (Vcc=1.8V)
Input Rise and Fall Time	1V/1ns
Input and Output Timing Reference Levels	1.5V (Vcc=3.3V or 5.0V)
	1/2Vcc (Vcc= 1.8V or 2.5V)
Output Load	See Fig. 1

* The above parameters are also guaranteed at industrial temperature range.

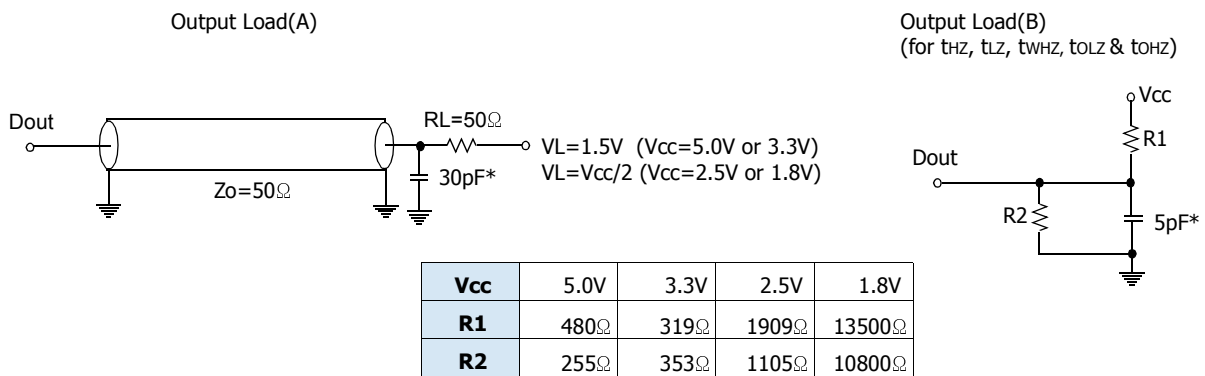

* Including Scope and Jig Capacitance

Fig. 1

Overshoot Timing

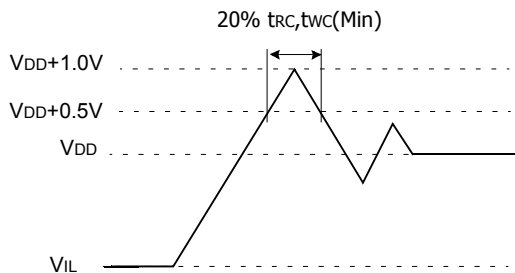

Undershoot Timing

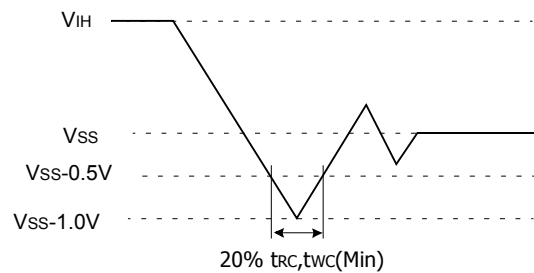

Fig. 2

Functional Description (x8 Mode)

$\overline{\text{CS}}$	$\overline{\text{WE}}$	$\overline{\text{OE}}$	Mode	I/O Pin	Supply Current
H	X	X*	Not Select	High-Z	ISB, ISB1
L	H	H	Output Disable	High-Z	Icc
L	H	L	Read	DOUT	Icc
L	L	X	Write	DIN	Icc

* X means Don't Care.

**S6R4016V1A, S6R4016C1A, S6R4016W1A
S6R4008V1A, S6R4008C1A, S6R4008W1A**

4M Async FAST SRAM

Functional Description (x16 Mode)

\overline{CS}	\overline{WE}	\overline{OE}	\overline{LB}^{**}	\overline{UB}^{**}	Mode	I/O Pin		Supply Current
						I/O ₀ ~I/O ₇	I/O ₈ ~I/O ₁₅	
H	X	X*	X	X	Not Select	High-Z	High-Z	ISB, ISB1
L	H	H	X	X	Output Disable	High-Z	High-Z	I _{CC}
L	X	X	H	H				
L	H	L	L	H	Read	DOUT	High-Z	I _{CC}
			H	L		High-Z	DOUT	
			L	L		DOUT	DOUT	
L	L	X	L	H	Write	DIN	High-Z	I _{CC}
			H	L		High-Z	DIN	
			L	L		DIN	DIN	

* X means Don't Care.

Data Retention Characteristics* (TA=0 to 70°C)

Parameter	Product	Operating V _{CC} (V)	Symbol	Test Condition	Min.	Typ.	Max.	Unit
V _{CC} for Data Retention	5.0V Product	5.0	V _{DR}	$\overline{CS} \geq V_{CC} - 0.2V$	2.0	-	5.5	V
	3.3V Product	3.3			2.0	-	3.6	
	Wide 2.4V ~ 3.6V	2.5/3.3			2.0	-	3.6	
	Wide 1.65V ~ 2.2V	1.8			1.5	-	3.6	
Data Retention Current	5.0V Product	5.0	I _{DR}	$V_{CC}=2.0V$ $\overline{CS} \geq V_{CC} - 0.2V$ $V_{IN} \geq V_{CC} - 0.2V$ or $V_{IN} \leq 0.2V$	-	-	5	mA
	3.3V Product	3.3			-	-	5	
	Wide 2.4V ~ 3.6V	2.5/3.3			-	-	6	
	Wide 1.65V ~ 2.2V	1.8		$V_{CC}=1.5V$ $\overline{CS} \geq V_{CC} - 0.2V$ $V_{IN} \geq V_{CC} - 0.2V$ or $V_{IN} \leq 0.2V$	-	-	6	
Data Retention Set-Up Time			t _{SDR}	See Data Retention	0	-	-	ns
Recovery Time			t _{RDR}	Wave form(below)	5	-	-	ms

* The above parameters are also guaranteed at industrial temperature range.

Data Retention Wave Form

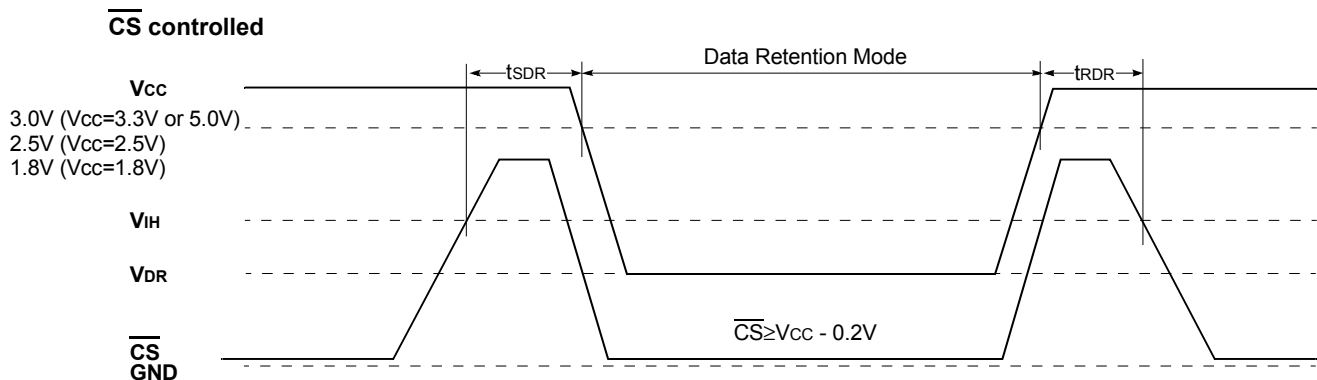

**S6R4016V1A, S6R4016C1A, S6R4016W1A
S6R4008V1A, S6R4008C1A, S6R4008W1A**

4M Async FAST SRAM

Read Cycle*

Parameter	Symbol	8ns		10ns		12ns		15ns		Unit
		Min	Max	Min	Max	Min	Max	Min	Max	
Read Cycle Time	t _{RC}	8	-	10	-	12	-	15	-	ns
Address Access Time	t _{AA}	-	8	-	10	-	12	-	15	ns
Chip Select to Output	t _{CO}	-	8	-	10	-	12	-	15	ns
Output Enable to Valid Output	t _{OE}	-	4	-	5	-	6	-	7	ns
\overline{UB} , \overline{LB} Access Time **	t _{BA}	-	4	-	5	-	6	-	7	ns
Chip Enable to Low-Z Output	t _{LZ}	3	-	3	-	3	-	3	-	ns
Output Enable to Low-Z Output	t _{OLZ}	0	-	0	-	0	-	0	-	ns
\overline{UB} , \overline{LB} Enable to Low-Z Output **	t _{BLZ}	0	-	0	-	0	-	0	-	ns
Chip Disable to High-Z Output	t _{HZ}	0	4	0	5	0	6	0	7	ns
Output Disable to High-Z Output	t _{OHZ}	0	4	0	5	0	6	0	7	ns
\overline{UB} , \overline{LB} Disable to High-Z Output **	t _{BHZ}	0	4	0	5	0	6	0	7	ns
Output Hold from Address Change	t _{OH}	3	-	3	-	3	-	3	-	ns
Chip Selection to Power Up Time	t _{PU}	0	-	0	-	0	-	0	-	ns
Chip Selection to Power Down Time	t _{PD}	-	8	-	10	-	12	-	15	ns

* The above parameters are also guaranteed for industrial temperature range.

Write Cycle*

Parameter	Symbol	8ns		10ns		12ns		15ns		Unit
		Min	Max	Min	Max	Min	Max	Min	Max	
Write Cycle Time	t _{WC}	8	-	10	-	12	-	15	-	ns
Chip Select to End of Write	t _{CW}	6	-	7	-	9	-	12	-	ns
Address Set-up Time	t _{AS}	0	-	0	-	0	-	0	-	ns
Address Valid to End of Write	t _{AW}	6	-	7	-	9	-	12	-	ns
Write Pulse Width(\overline{OE} High)	t _{WP}	6	-	7	-	9	-	12	-	ns
Write Pulse Width(\overline{OE} Low)	t _{WP1}	8	-	10	-	12	-	15	-	ns
\overline{UB} , \overline{LB} Valid to End of Write **	t _{BW}	6	-	7	-	9	-	12	-	ns
Write Recovery Time	t _{WR}	0	-	0	-	0	-	0	-	ns
Write to Output High-Z	t _{WHZ}	0	4	0	5	0	6	0	7	ns
Data to Write Time Overlap	t _{DW}	4	-	5	-	7	-	8	-	ns
Data Hold from Write Time	t _{DH}	0	-	0	-	0	-	0	-	ns
End of Write to Output Low-Z	t _{OW}	3	-	3	-	3	-	3	-	ns

* The above parameters are also guaranteed for industrial temperature range.

Timing Diagrams

Timing Waveform Of Read Cycle(1) (Address Controlled, $\overline{CS}=\overline{OE}=V_{IL}$, $\overline{WE}=V_{IH}$, $\overline{UB}, \overline{LB}=V_{IL}$ **)

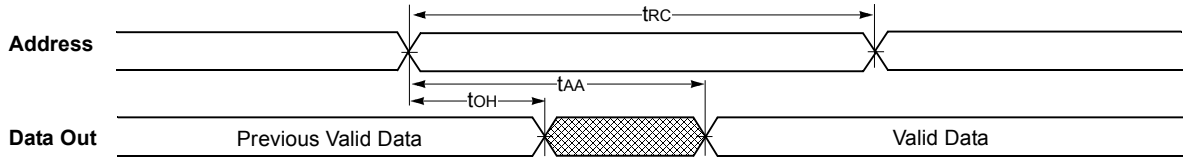

** Those parameters are applied for x16 mode only.

Timing Waveform Of Read Cycle(2) ($\overline{WE}=V_{IH}$)

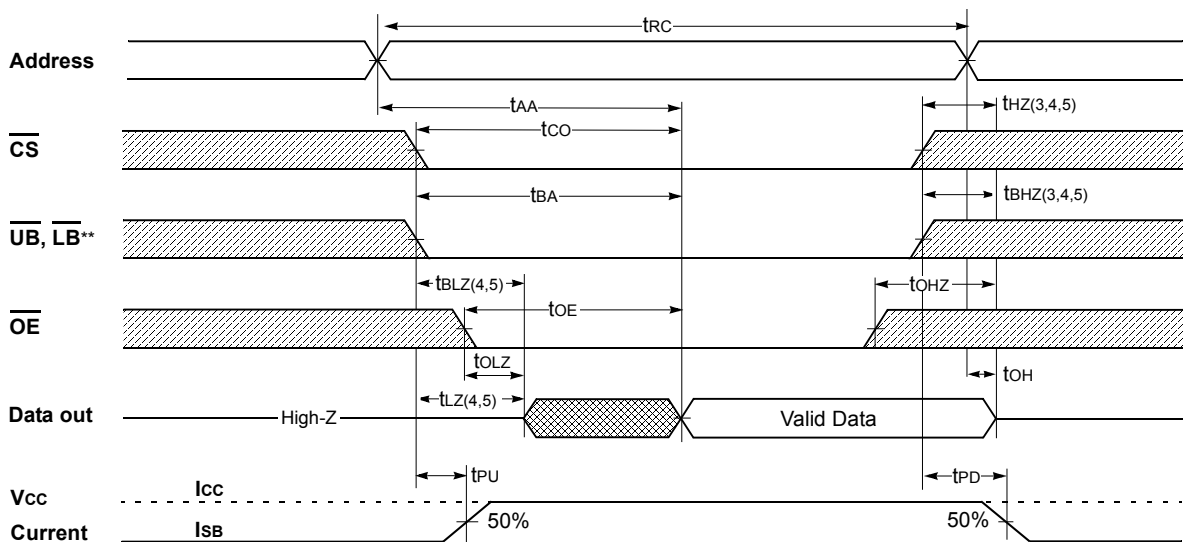

NOTES(Read Cycle)

1. \overline{WE} is high for read cycle.
2. All read cycle timing is referenced from the last valid address to the first transition address.
3. t_{HZ} and t_{OHZ} are defined as the time at which the outputs achieve the open circuit condition and are not referenced to V_{OH} or V_{OL} levels.
4. At any given temperature and voltage condition, $t_{HZ}(\text{Max.})$ is less than $t_{LZ}(\text{Min.})$ both for a given device and from device to device.
5. Transition is measured $\pm 200\text{mV}$ from steady state voltage with Load(B). This parameter is sampled and not 100% tested.
6. Device is continuously selected with $\overline{CS}=V_{IL}$.
7. Address valid prior to coincident with \overline{CS} transition low.
8. For common I/O applications, minimization or elimination of bus contention conditions is necessary during read and write cycle.

** Those parameters are applied for x16 mode only.

Timing Waveform Of Write Cycle(1) (\overline{OE} Clock)

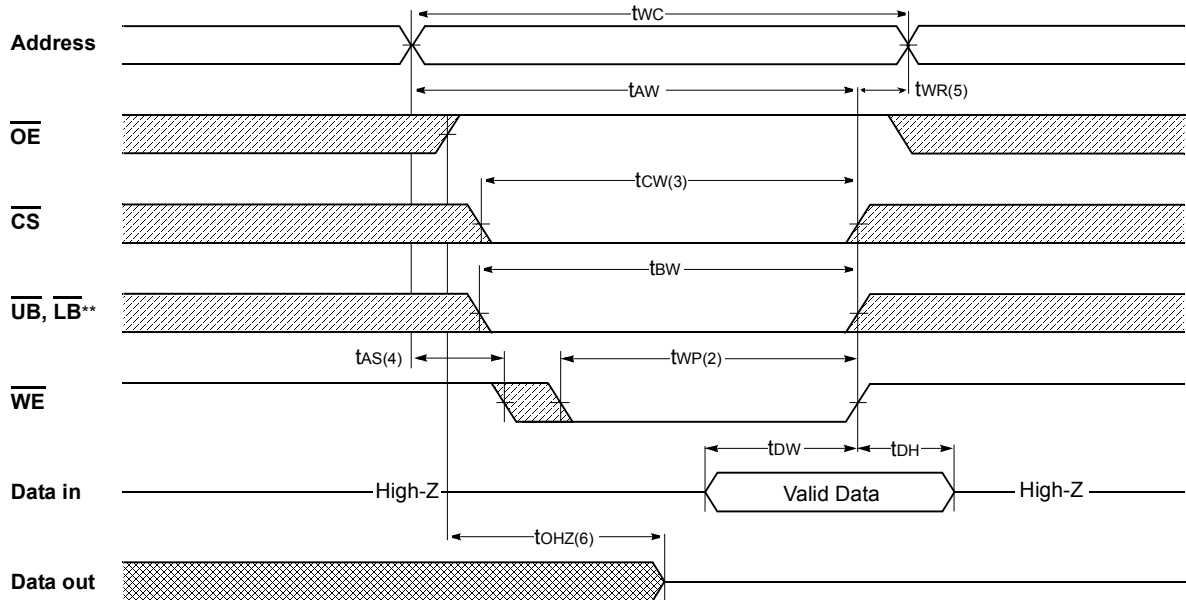

** Those parameters are applied for x16 mode only.

Timing Waveform Of Write Cycle(2) (\overline{OE} =Low fixed)

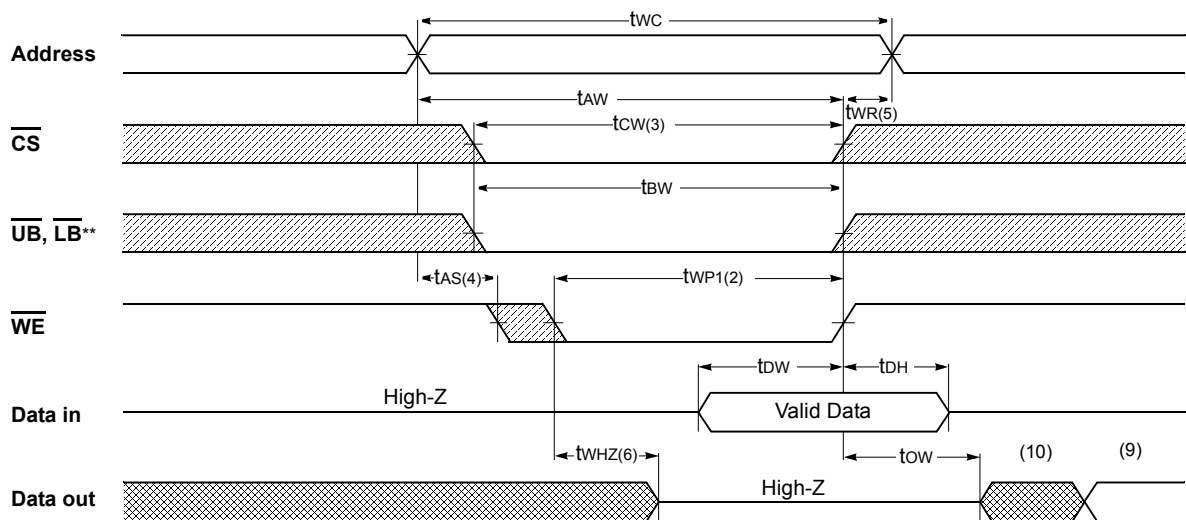

** Those parameters are applied for x16 mode only.

Timing Waveform Of Write Cycle(3) (\overline{CS} =Controlled)

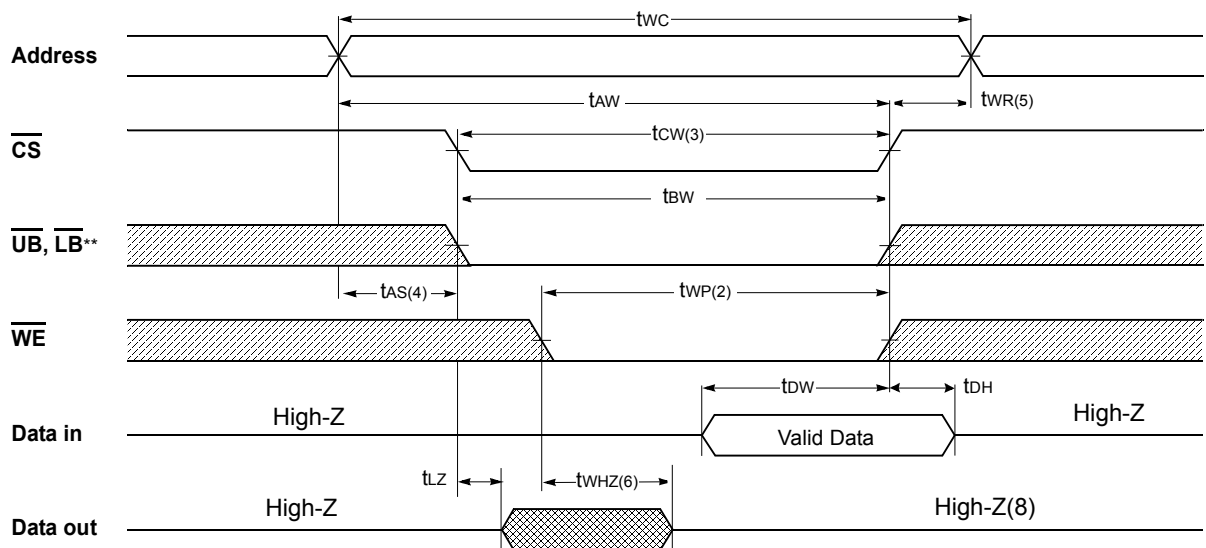

** Those parameters are applied for x16 mode only.

Timing Waveform Of Write Cycle(4) (\overline{UB} , \overline{LB} Controlled)

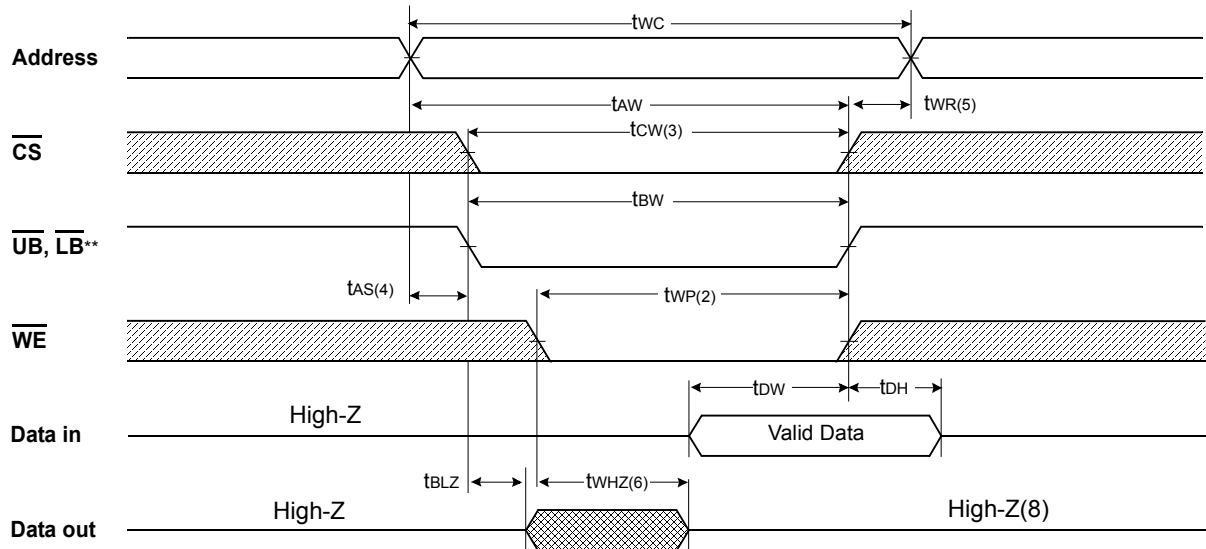

NOTES(Write Cycle)

1. All write cycle timing is referenced from the last valid address to the first transition address.
2. A write occurs during the overlap of a low \overline{CS} , \overline{WE} , \overline{LB} and \overline{UB} . A write begins at the latest transition \overline{CS} going low and \overline{WE} going low ; A write ends at the earliest transition \overline{CS} going high or \overline{WE} going high. t_{WP} is measured from the beginning of write to the end of write.
3. t_{CW} is measured from the later of \overline{CS} going low to end of write.
4. t_{AS} is measured from the address valid to the beginning of write.
5. t_{WR} is measured from the end of write to the address change. t_{WR} applied in case a write ends as \overline{CS} or \overline{WE} going high.
6. If \overline{OE} , \overline{CS} and \overline{WE} are in the Read Mode during this period, the I/O pins are in the output low-Z state. Inputs of opposite phase of the output must not be applied because bus contention can occur.
7. For common I/O applications, minimization or elimination of bus contention conditions is necessary during read and write cycle.
8. If \overline{CS} goes low simultaneously with \overline{WE} going or after \overline{WE} going low, the outputs remain high impedance state.
9. Dout is the read data of the new address.
10. When \overline{CS} is low : I/O pins are in the output state. The input signals in the opposite phase leading to the output should not be applied.

** Those parameters are applied for x16 mode only.

**S6R4016V1A, S6R4016C1A, S6R4016W1A
S6R4008V1A, S6R4008C1A, S6R4008W1A**

4M Async FAST SRAM

Package Dimensions

44-TSOP2-400BF

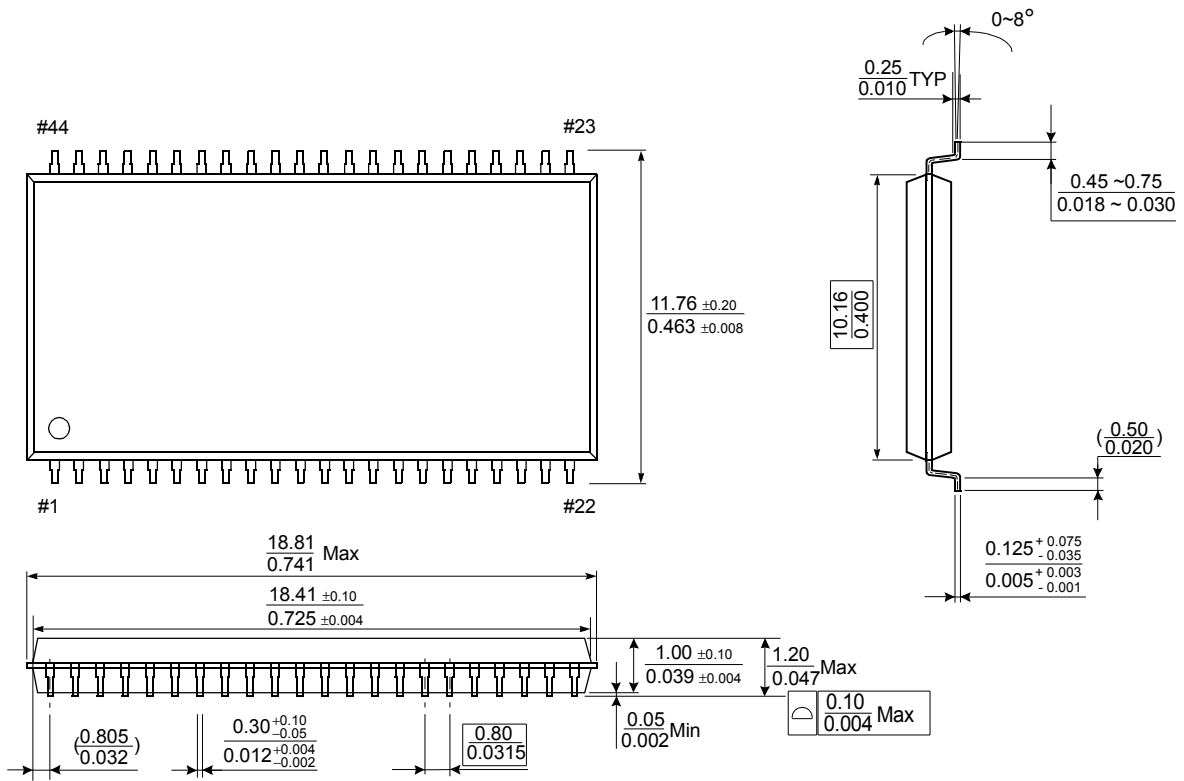

Units: millimeters/Inches

Package Dimensions

48-FBGA

6mm x 8mm Body, 0.75mm Bump Pitch, 6 x 8 Ball Grid Array

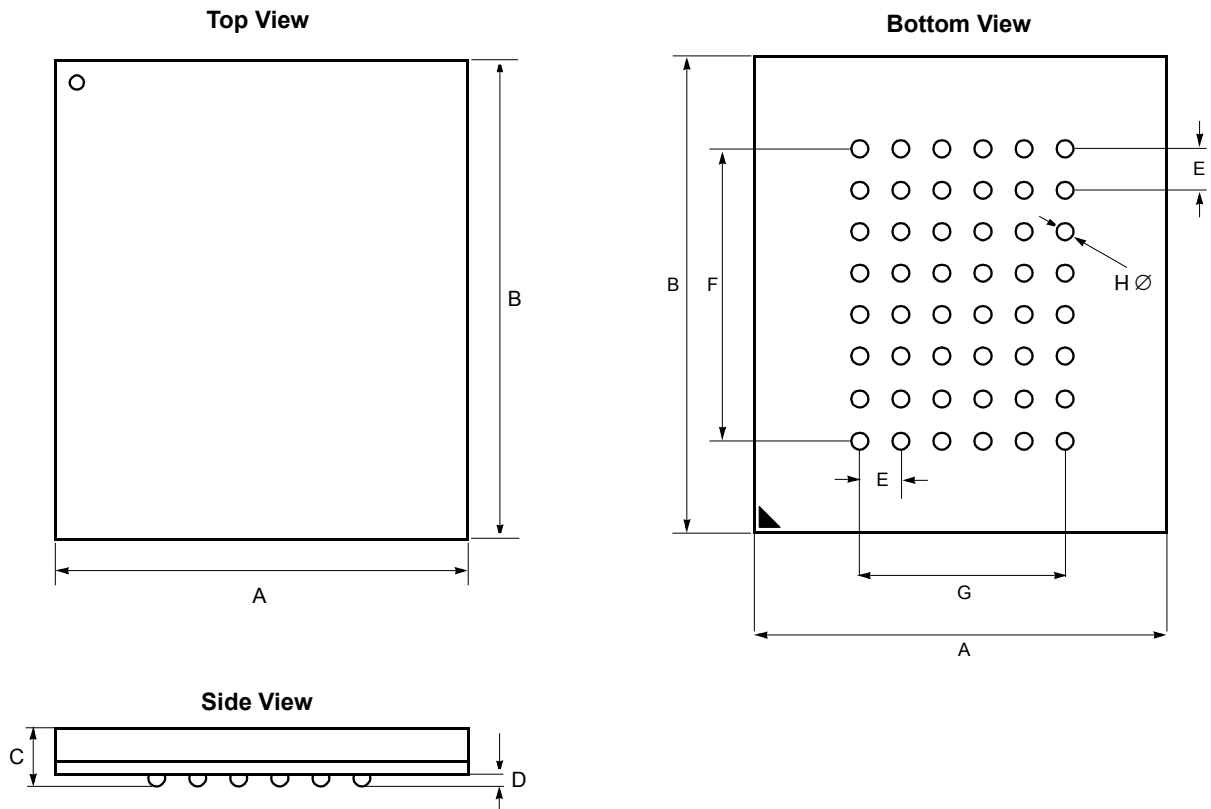

Symbol	Value	Units	Note	Symbol	Value	Units	Note
A	6 ± 0.1	mm		E	0.75	mm	
B	8 ± 0.1	mm		F	5.25	mm	
C	1.1 ± 0.1	mm		G	3.75	mm	
D	0.25 ± 0.05	mm		H	0.35 ± 0.05	mm	

Package Dimensions

36-FBGA

6mm x 8mm Body, 0.75mm Bump Pitch

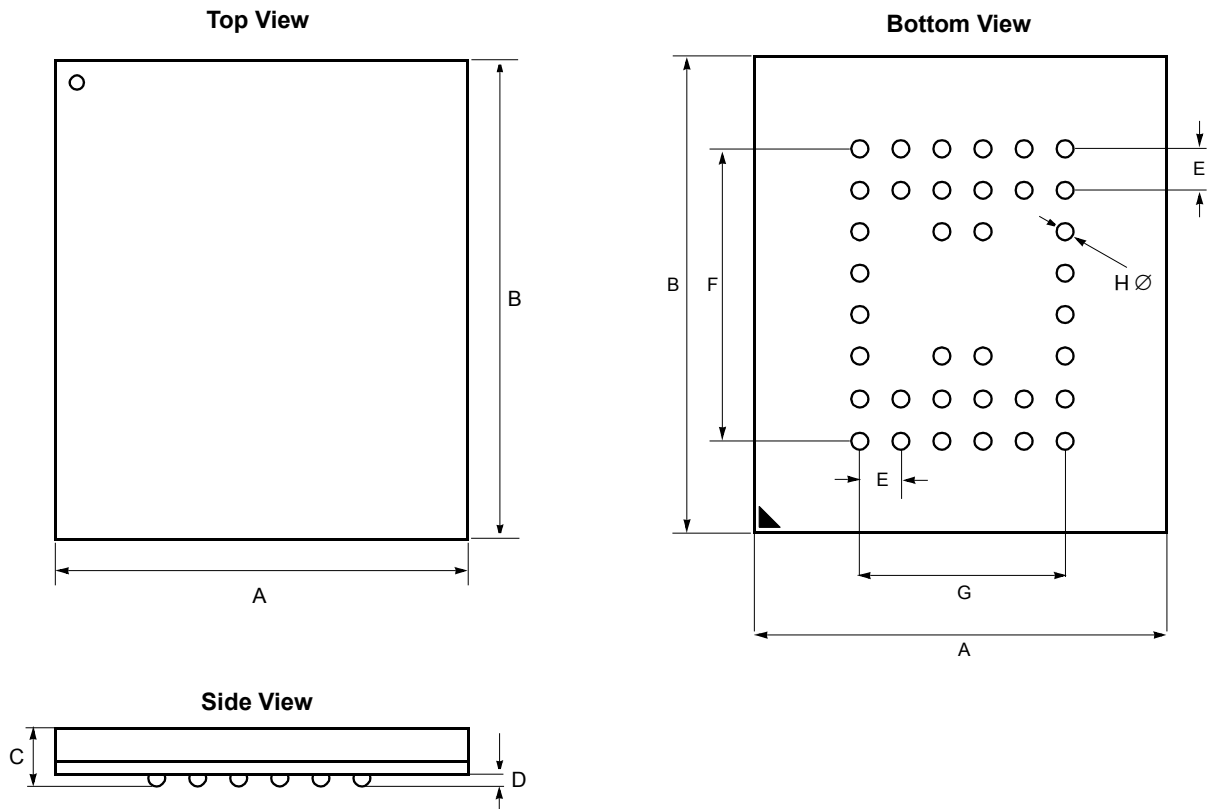

Symbol	Value	Units	Note	Symbol	Value	Units	Note
A	6 ± 0.1	mm		E	0.75	mm	
B	8 ± 0.1	mm		F	5.25	mm	
C	1.1 ± 0.1	mm		G	3.75	mm	
D	0.25 ± 0.05	mm		H	0.35 ± 0.05	mm	