

S72WS-N Based MCP/PoP Products

1.8 Volt-only x16 Flash Memory and SDRAM on Split Bus

256/512 Mb Simultaneous Read/Write, Burst Mode Flash Memory

512 Mb NAND Flash

1024 Mb NAND Interface ORNAND Flash Memory on Bus 1

512/256/128 Mb (8M/4M/2M x 16-bit x 4 Banks) Mobile SDRAM on Bus 2



Data Sheet

**ADVANCE
INFORMATION**

Notice to Readers: This document states the current technical specifications regarding the Spansion product(s) described herein. Each product described herein may be designated as Advance Information, Preliminary, or Full Production. See ["Notice On Data Sheet Designations"](#) for definitions.

Notice On Data Sheet Designations

Spansion LLC issues data sheets with Advance Information or Preliminary designations to advise readers of product information or intended specifications throughout the product life cycle, including development, qualification, initial production, and full production. In all cases, however, readers are encouraged to verify that they have the latest information before finalizing their design. The following descriptions of Spansion data sheet designations are presented here to highlight their presence and definitions.

Advance Information

The Advance Information designation indicates that Spansion LLC is developing one or more specific products, but has not committed any design to production. Information presented in a document with this designation is likely to change, and in some cases, development on the product may discontinue. Spansion LLC therefore places the following conditions upon Advance Information content:

"This document contains information on one or more products under development at Spansion LLC. The information is intended to help you evaluate this product. Do not design in this product without contacting the factory. Spansion LLC reserves the right to change or discontinue work on this proposed product without notice."

Preliminary

The Preliminary designation indicates that the product development has progressed such that a commitment to production has taken place. This designation covers several aspects of the product life cycle, including product qualification, initial production, and the subsequent phases in the manufacturing process that occur before full production is achieved. Changes to the technical specifications presented in a Preliminary document should be expected while keeping these aspects of production under consideration. Spansion places the following conditions upon Preliminary content:

"This document states the current technical specifications regarding the Spansion product(s) described herein. The Preliminary status of this document indicates that product qualification has been completed, and that initial production has begun. Due to the phases of the manufacturing process that require maintaining efficiency and quality, this document may be revised by subsequent versions or modifications due to changes in technical specifications."

Combination

Some data sheets will contain a combination of products with different designations (Advance Information, Preliminary, or Full Production). This type of document will distinguish these products and their designations wherever necessary, typically on the first page, the ordering information page, and pages with the DC Characteristics table and the AC Erase and Program table (in the table notes). The disclaimer on the first page refers the reader to the notice on this page.

Full Production (No Designation on Document)

When a product has been in production for a period of time such that no changes or only nominal changes are expected, the Preliminary designation is removed from the data sheet. Nominal changes may include those affecting the number of ordering part numbers available, such as the addition or deletion of a speed option, temperature range, package type, or V_{IO} range. Changes may also include those needed to clarify a description or to correct a typographical error or incorrect specification. Spansion LLC applies the following conditions to documents in this category:

"This document states the current technical specifications regarding the Spansion product(s) described herein. Spansion LLC deems the products to have been in sufficient production volume such that subsequent versions of this document are not expected to change. However, typographical or specification corrections, or modifications to the valid combinations offered may occur."

Questions regarding these document designations may be directed to your local AMD or Fujitsu sales office.

S72WS-N based MCP/PoP Products

1.8 Volt-only x16 Flash Memory and SDRAM on Split Bus

256/512 Mb Simultaneous Read/Write, Burst Mode Flash Memory

512 Mb NAND Flash

1024 Mb NAND Interface ORNAND Flash Memory on Bus 1

512/256/128 Mb (8M/4M/2M x 16-bit x 4 Banks) Mobile SDRAM on Bus 2



Data Sheet

ADVANCE
INFORMATION

Distinctive Characteristics

MCP Features

- Power supply voltage of 1.7 to 1.95V

High Performance

- Flash access time: 80 ns for NOR Flash, 25 ns for ORNAND Flash
- Flash burst frequencies: 54 MHz, 66MHz, 80MHz
- Mobile SDRAM burst frequency: 104 MHz, 133 MHz (DDR)
- Package:
 - 9.0 x 12.0 mm MCP BGA
 - 11.0 x 13.0 mm MCP BGA
 - 15.0 x 15.0 x 1.2 mm MCP Package-on-Package (PoP)
- Operating Temperature
 - -25°C to +85°C (wireless)

General Description

The S72WS series is a product line of stacked Multi-Chip Product (MCP) packages and consists of:

- One or two NOR flash memory dies
- One NAND Interface ORNAND die
- Separate bus for one or more Mobile SDRAM die

The products covered by this document are listed in the table below.

Device	NOR Flash Density			NAND Flash Density		SDRAM Density		
	512Mb	256Mb	128Mb	1024Mb	512Mb	512Mb	256Mb	128Mb
S72WS256ND0		X						X
S72WS256NDE	X							X
S72WS256NEE	X						X	
S72WS512NFG	X			X		X		
S72WS512NEG	X			X			X	
S72WS512NEF	X				X		X	
S72WS512NFF	X				X	X		

Note: For a list of PoP OPNs, please contact the local sales representative or refer to the [Ordering Information valid combinations tables](#).

For detailed specifications, please refer to the individual data sheets.

Document	Publication Identification Number (PID)
S29WS256N	S29WS-N_00
S30MS01GP/512P	S30MS-P_00
128 Mb Mobile SDRAM Type 1	SDRAM_01
128 Mb Mobile SDRAM Type 2	SDRAM_05
128 Mb Mobile DDR-DRAM Type 5	SDRAM_07
256 Mb Mobile SDRAM Type 2	SDRAM_05
512 Mb Mobile DDR-DRAM Type 1	SDRAM_09
512 Mb Mobile SDRAM Type 4	SDRAM_06
512 Mb NAND Type 1	NAND_01
512 Mb Mobile DDR-DRAM Type 5	DRAM_04
512 Mb Mobile DDR-DRAM Type 2	DRAM_05

Publication Number S72WS-N_00 Revision A Amendment 8 Issue Date June 1, 2006

Table of Contents

S72WS-N Based MCP/PoP Products	i
1 Product Selector Guide	3
1.1 NOR Flash + DRAM Products	3
1.2 NOR Flash + ORNAND Flash + DRAM Products	4
2 MCP Block Diagram	5
2.1 NOR Flash + ORNAND Flash + DRAM Products	5
3 Connection Diagram	6
3.1 2 x 256Mb NOR Flash with 256Mb SDRAM	6
3.2 2 x 256Mb NOR Flash with 128Mb SDRAM	7
3.3 256Mb NOR Flash with 128Mb SDR/DDR-DRAM	8
3.4 512 Mb NOR Flash with 1024-Mb ORNAND on Bus 1 and 512 or 256-Mb SDRAM on Bus 2	9
3.4.1 x16 ORNAND-based MCP	9
3.5 512Mb NOR Flash with 1024-Mb ORNAND on Bus 1 and 512 or 256 Mb SDRAM on Bus 2	10
3.5.1 x8 ORNAND-based MCP	10
3.6 512Mb NOR Flash with 512-Mb NAND on Bus 1 and 512-Mb SDRAM on Bus 2	11
3.6.1 x16 ORNAND-based MCP	11
3.6.2 Connection Diagram for 15 x 15 Package-on-Package	12
3.7 Lookahead Diagram on Split Bus	13
3.8 NOR Flash and DRAM Input/Output Descriptions	14
3.8.1 ORNAND Signal Descriptions	15
4 Ordering Information	16
5 Physical Dimensions	20
5.1 TLDI37—137-ball Fine-Pitch Ball Grid Array (FBGA) 12 x 9 mm Package	20
5.2 FEAI37—137-ball Fine-Pitch Ball Grid Array (FBGA) 13 x 11 mm Package	21
5.3 FVDI37—137-ball Fine-Pitch Ball Grid Array (FBGA) 11 x 13 mm Package	22
5.4 BWAI60—160-ball Fine-Pitch Ball Grid Array (FBGA) 15 x 15 mm Package	23
5.5 BWBI60—160-ball Fine-Pitch Ball Grid Array (FBGA) 15 x 15 mm Package	24
5.6 BTAI60—160-ball Fine-Pitch Ball Grid Array (FBGA) 15 x 15 mm Package	25
5.7 ALHI60—160-ball Fine-Pitch Ball Grid Array (FBGA) 15 x 15 mm Package	26
6 MCP Revision Summary	27

I Product Selector Guide

I.1 NOR Flash + DRAM Products

Device-Model#	Flash Density (Code)	Flash Density (Data)	Burst Speed (MHz)	SDRAM Density	SDRAM burst Speed (MHz)	DRAM Supplier	DYB	Package
S72WS256ND0BAWB7	256 Mb	—	54 MHz	128	104 MHz	1	sector unprotected	9x12x1.2
S72WS256ND0BAWB8						2		
S72WS256NDEBAWU7	256 Mb	256 Mb	54 MHz	128	104 MHz	1	sector unprotected	9x12x1.4
S72WS256NDEBAWUB				256		2		
S72WS256NEEBAWU7				1				
S72WS256NEEBAWUB				2				
S72WS256ND0BFWB7	256 Mb	—	54 MHz	128	104 MHz	1	sector unprotected	9x12x1.2
S72WS256ND0BFWB8						2		
S72WS256NDEBFWU7	256 Mb	256 Mb	54 MHz	128	104 MHz	1	sector unprotected	9x12x1.4
S72WS256NDEBFWUB				256		2		
S72WS256NEEBAWU7				1				
S72WS256NEEBAWUB				2				
S72WS256ND0KFWD3	256 Mb		66 MHz	128	133 MHz (DDR)	5	sector unprotected	15x15x1.25
S72WS256ND0BFW93					133 MHz (DDR)		sector unprotected	9x12x1.2

I.2 NOR Flash + ORNAND Flash + DRAM Products

Device-Model#	NOR Flash Density	ORNAND Flash Density	SDRAM Density	Flash Speed	DRAM Speed	Supplier	ORNAND Bus Width	ECC required?	Package
S72WS512NFFBFWZ2	512Mb	512Mb (NAND)		66MHz	133MHz (DDR)	DRAM Type 1	X16	Yes	11x13x1.4mm
S72WS512NFFBFWZJ						DRAM Type 5			
S72WS512NFG-L7	512Mb	1024Mb	512Mb	54MHz	104MHz	DRAM Type 4	X8	No	11x13x1.4mm
S72WS512NFG-L6				66MHz					
S72WS512NFG-L5				80MHz					
S72WS512NFG-47				54MHz					
S72WS512NFG-46				66MHz					
S72WS512NFG-45				80MHz					
S72WS512NFG-LZ				54MHz					
S72WS512NFG-LY				66MHz					
S72WS512NFG-LW				80MHz					
S72WS512NFG-4Z				54MHz					
S72WS512NFG-4Y				66MHz					
S72WS512NFG-4W				80MHz					
S72WS512NFG-N7				54MHz					
S72WS512NFG-N6				66MHz					
S72WS512NFG-N5				80MHz					
S72WS512NFG-67				54MHz					
S72WS512NFG-66				66MHz					
S72WS512NFG-65				80MHz					
S72WS512NFG-NZ				54MHz					
S72WS512NFG-NY				66MHz					
S72WS512NFG-NW				80MHz					
S72WS512NFG-6Z				54MHz					
S72WS512NFG-6Y				66MHz					
S72WS512NFG-6W				80MHz					
S72WS512NEG-LZ				54MHz					
S72WS512NEG-LY				66MHz					
S72WS512NEG-LW				80MHz					
S72WS512NEG-4Z				54MHz					
S72WS512NEG-4Y				66MHz					
S72WS512NEG-4W				80MHz					
S72WS512NEG-NZ				54MHz					
S72WS512NEG-NY				66MHz					
S72WS512NEG-NW	80MHz								
S72WS512NEG-6Z	54MHz								
S72WS512NEG-6Y	66MHz								
S72WS512NEG-6W	80MHz								
S72WS512NEFKFWHJ	512Mb	512Mb (NAND)	256Mb	66MHz	133MHz (DDR)	DRAM Type2	x16	Yes	15x15x1.25mm
S72WS512NFFKFWZ2			512Mb			DRAM Type 1			15x15x1.25mm
S72WS512NFFKFWZJ			512Mb			DRAM Type 5			15x15x1.25mm

2 MCP Block Diagram

2.1 NOR Flash + ORNAND Flash + DRAM Products

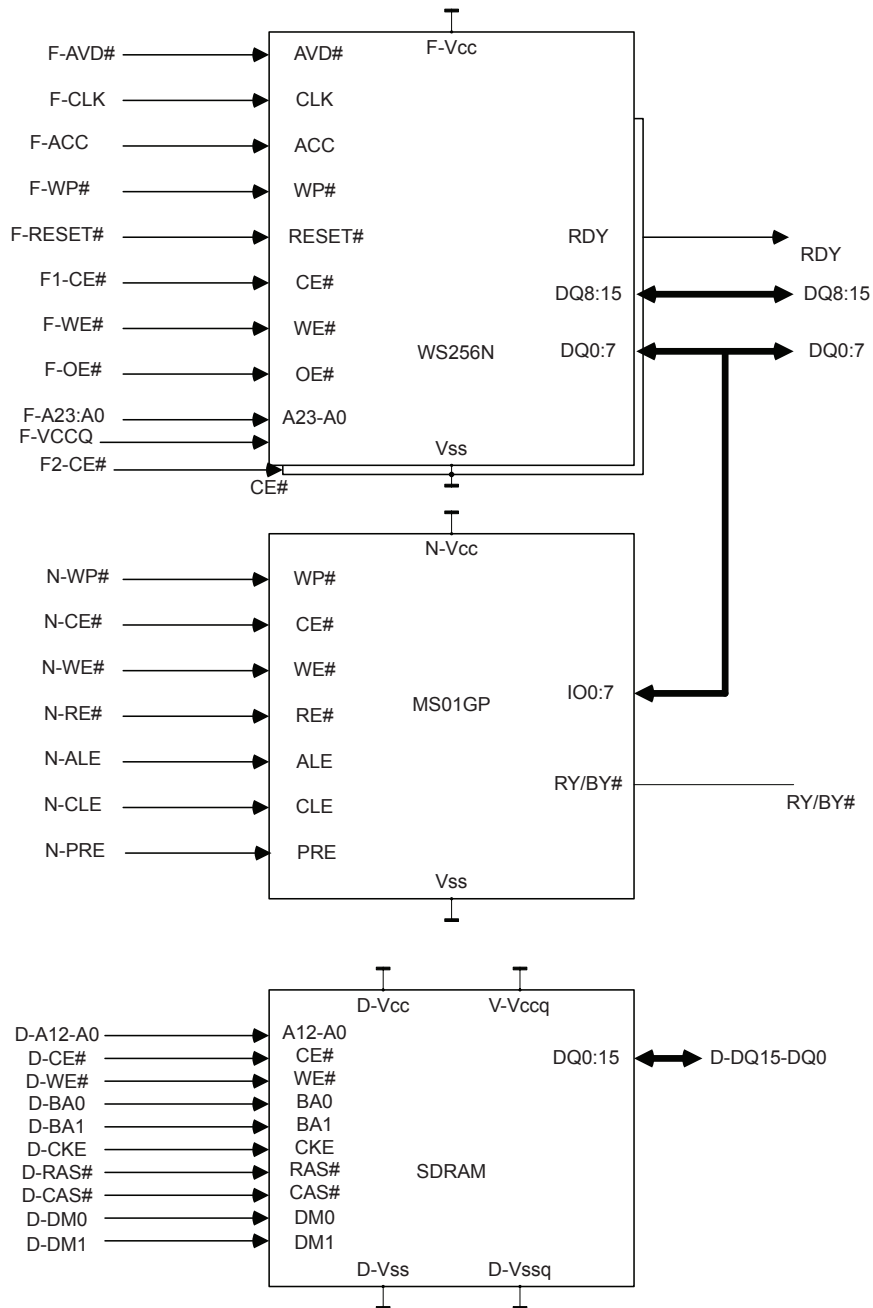

Notes:

1. For a one-Flash configuration, F1-CE# = CE#.
For a two-Flash configuration, F1-CE# = CE for Flash 1 and F2-CE# = CE for Flash 2; F2-CE# is the chip-enable pin for the second Flash.
2. If ORNAND is not present in the MCP, then the MS01GP block will not be present in the figure above. In that case, the common signals go only to the WS256N flash, while the SDRAM signals remain unchanged.
3. If ORNAND supports a x16 bus, then NOR DQ0-DQ15 is shared with ORNAND I/O0-I/O15.

3 Connection Diagram

3.1 2 x 256Mb NOR Flash with 256Mb SDRAM

137-ball Fine-Pitch Ball Grid Array
(Top View, Balls Facing Down)

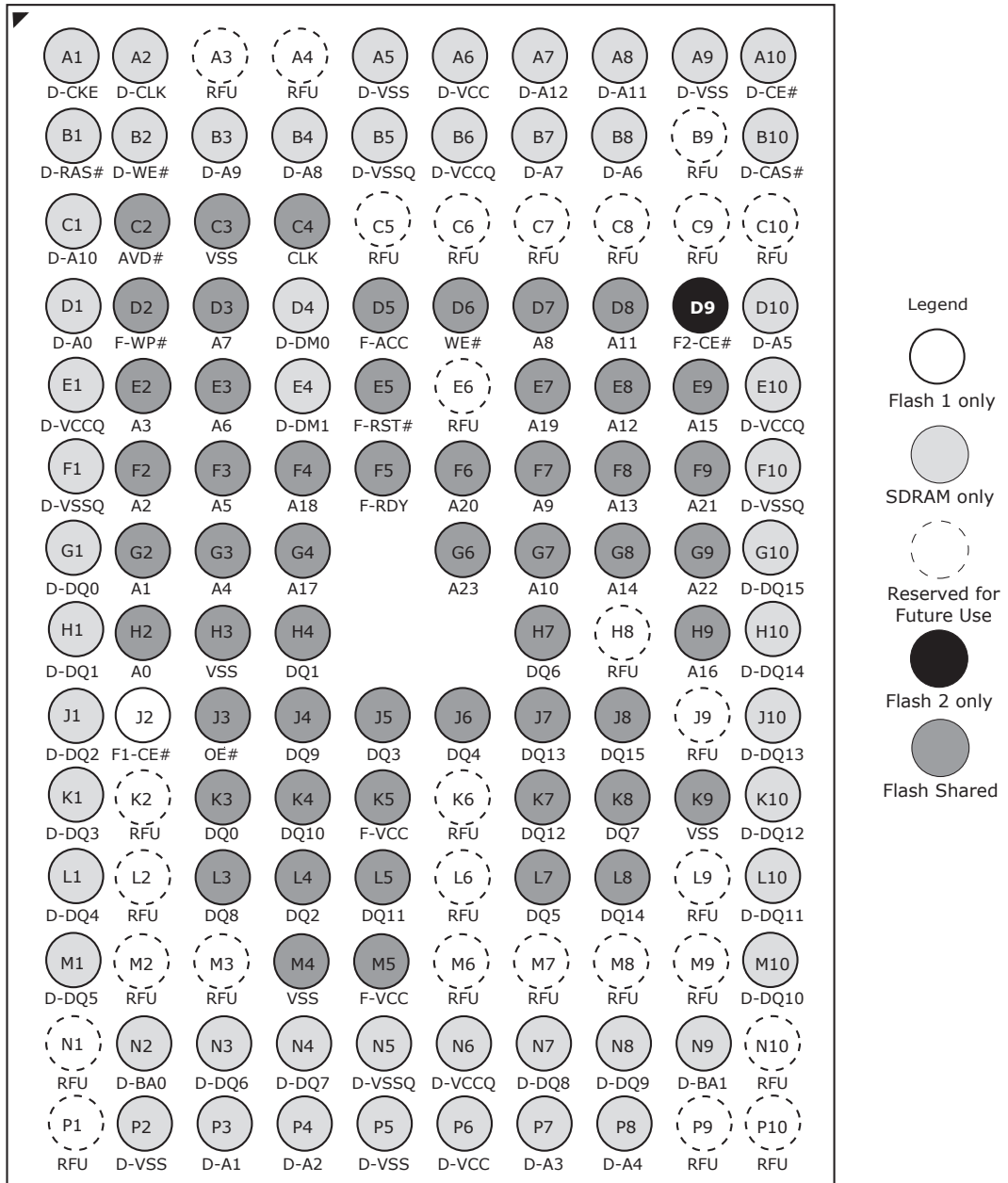

Note: M8 is RFU for SDR-DRAM and F-V_{CCQ} for DDR-DRAM, as indicated in subsequent connection diagrams.

3.2 2 x 256Mb NOR Flash with I28Mb SDRAM

137-ball Fine-Pitch Ball Grid Array
(Top View, Balls Facing Down)

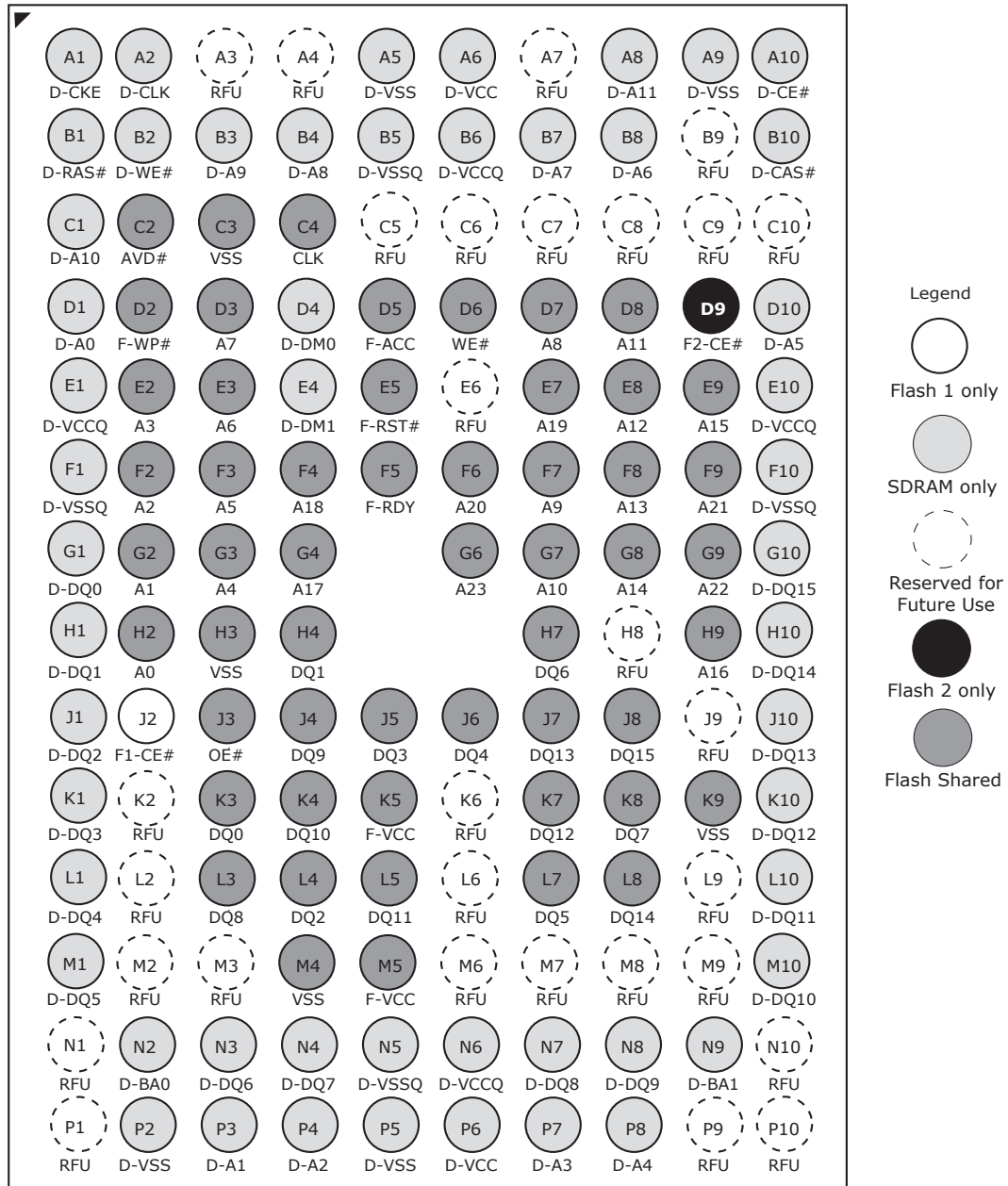

Note: M8 is RFU for SDR-DRAM and F-VCCQ for DDR-DRAM, as indicated in subsequent connection diagrams.

3.3 256Mb NOR Flash with I28Mb SDR/DDR-DRAM

137-ball Fine-Pitch Ball Grid Array
(Top View, Balls Facing Down)

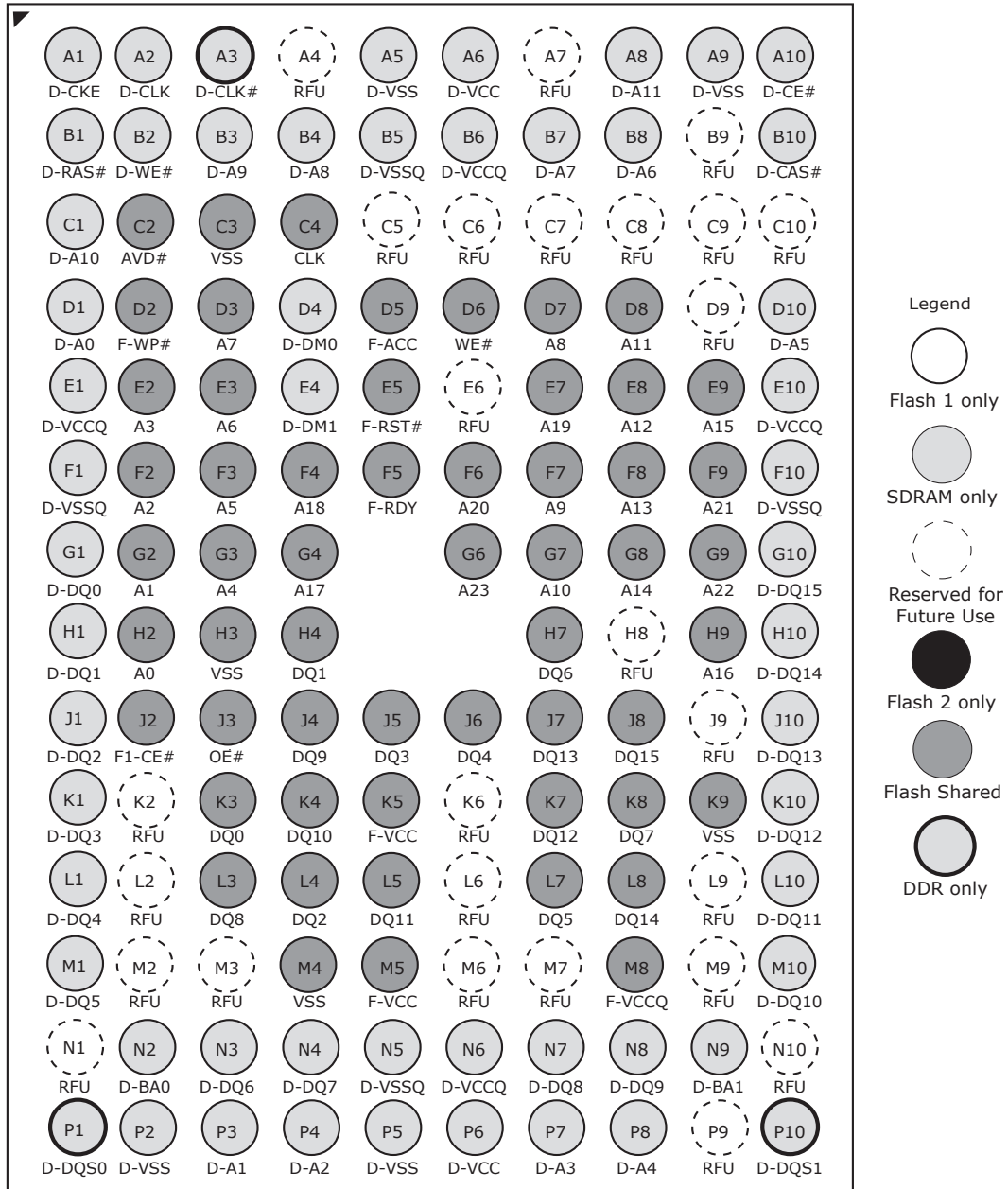

Note: DDR-only signals are RFUs in the case of the SDR-DRAM based MCPs.

3.4 512 Mb NOR Flash with 1024-Mb ORNAND on Bus 1 and 512 or 256-Mb SDRAM on Bus 2

3.4.1 x16 ORNAND-based MCP

137-ball Fine-Pitch Ball Grid Array
(Top View, Balls)

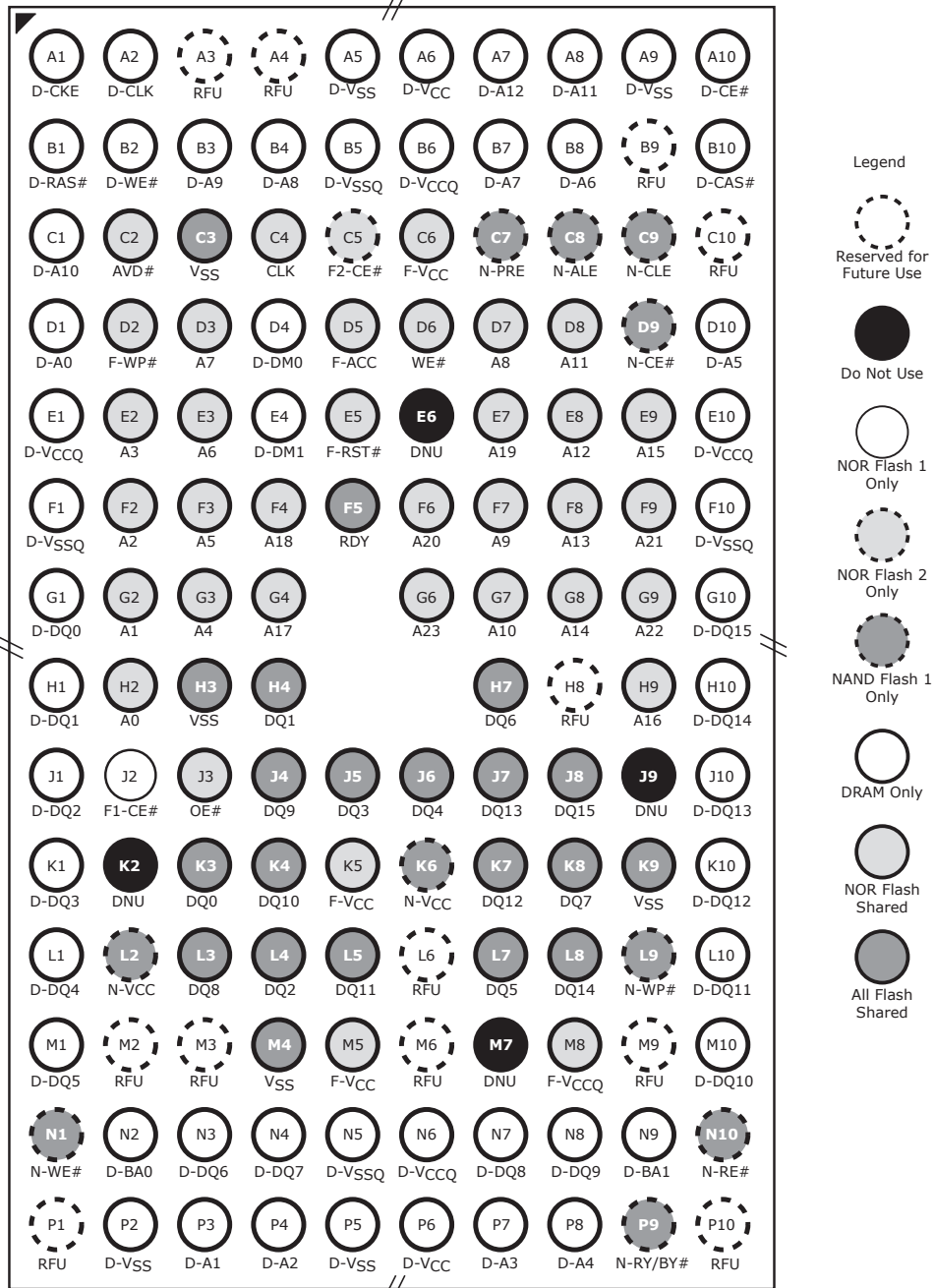

Note: 1.DDR-only signals are RFU in the case of SDR-DRAM based MCPs.

3.5 512Mb NOR Flash with 1024-Mb ORNAND on Bus 1 and 512 or 256 Mb SDRAM on Bus 2

3.5.1 x8 ORNAND-based MCP

137-ball Fine-Pitch Ball Grid Array
(Top View, Balls Facing Down)

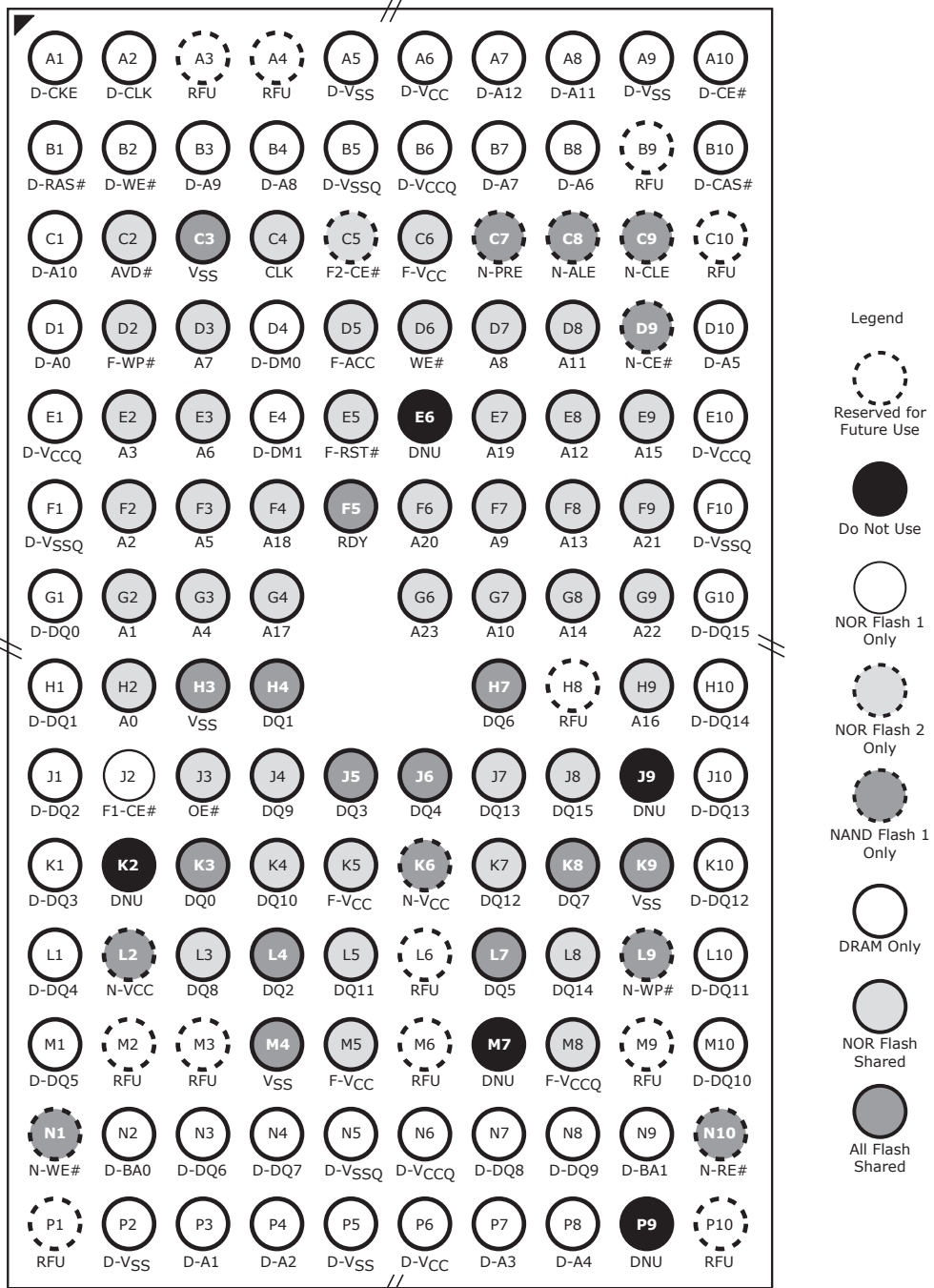

3.6 512Mb NOR Flash with 512-Mb NAND on Bus 1 and 512-Mb SDRAM on Bus 2

3.6.1 x16 ORNAND-based MCP

137-ball Fine-Pitch Ball Grid Array
(Top View, Balls Facing Down)

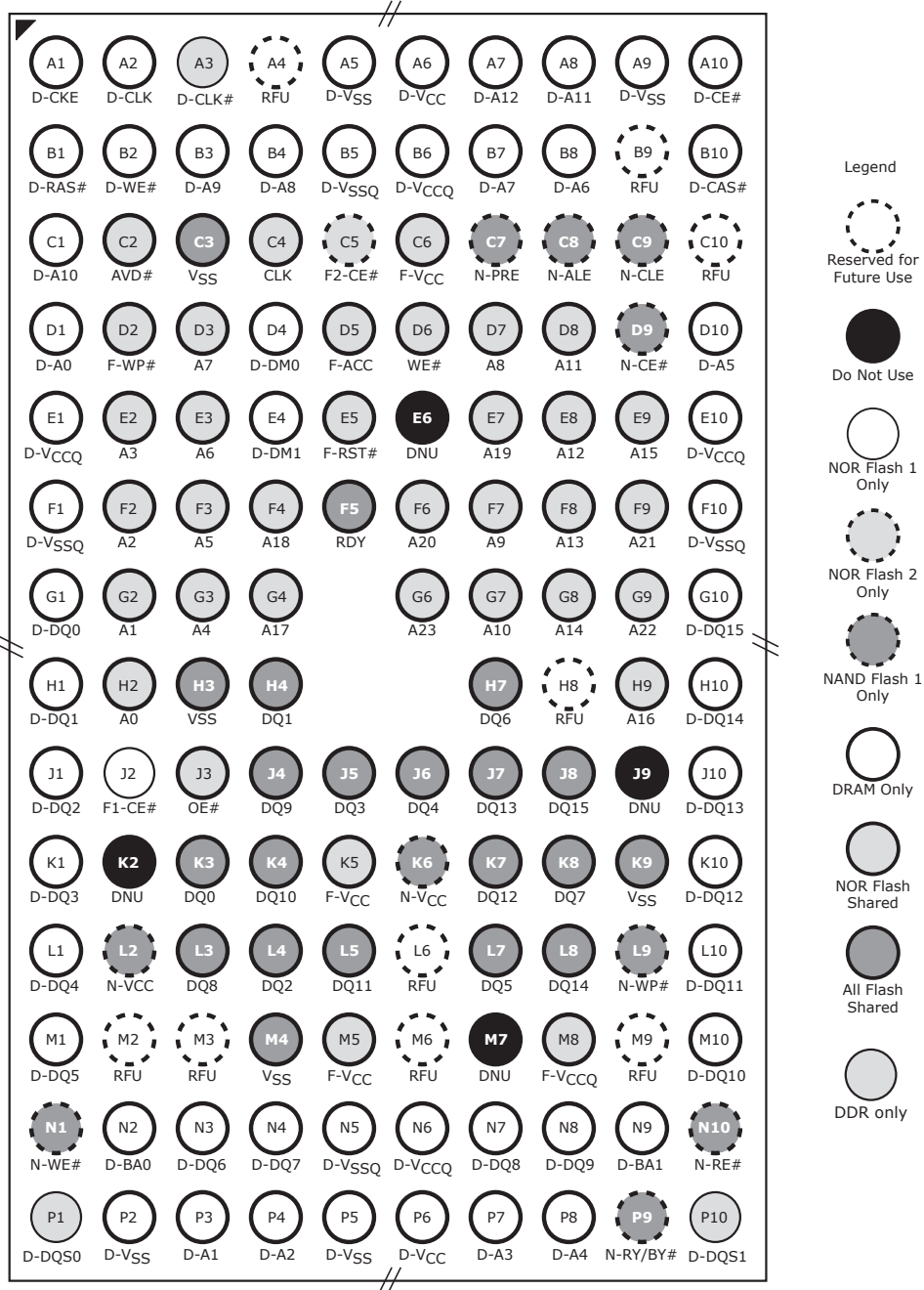

Special Handling Instructions For FBGA Package

Special handling is required for Flash Memory products in FBGA packages.

Flash memory devices in FBGA packages may be damaged if exposed to ultrasonic cleaning methods. The package and/or data integrity may be compromised if the package body is exposed to temperatures above 150°C for prolonged periods of time.

3.6.2 Connection Diagram for 15 x 15 Package-on-Package

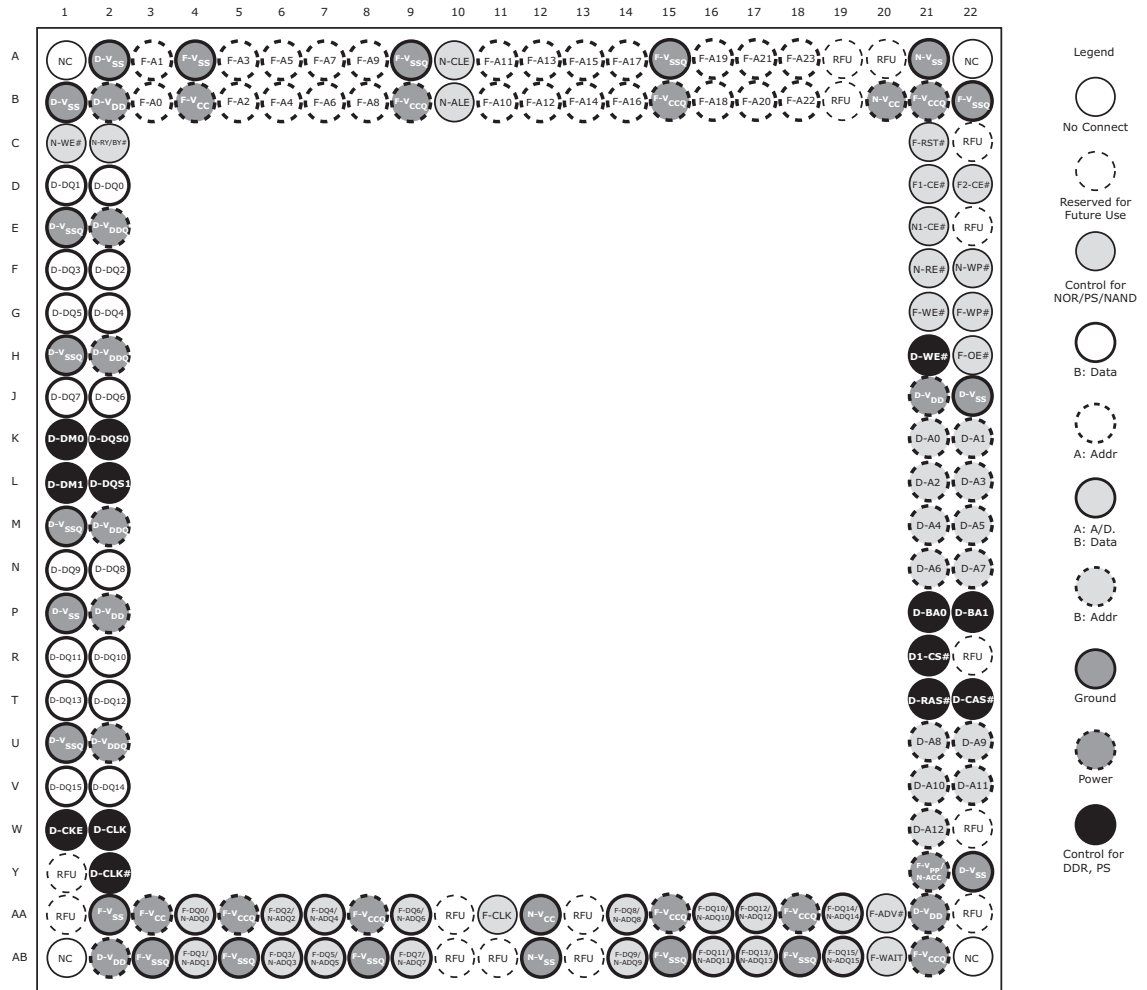

3.7 Lookahead Diagram on Split Bus

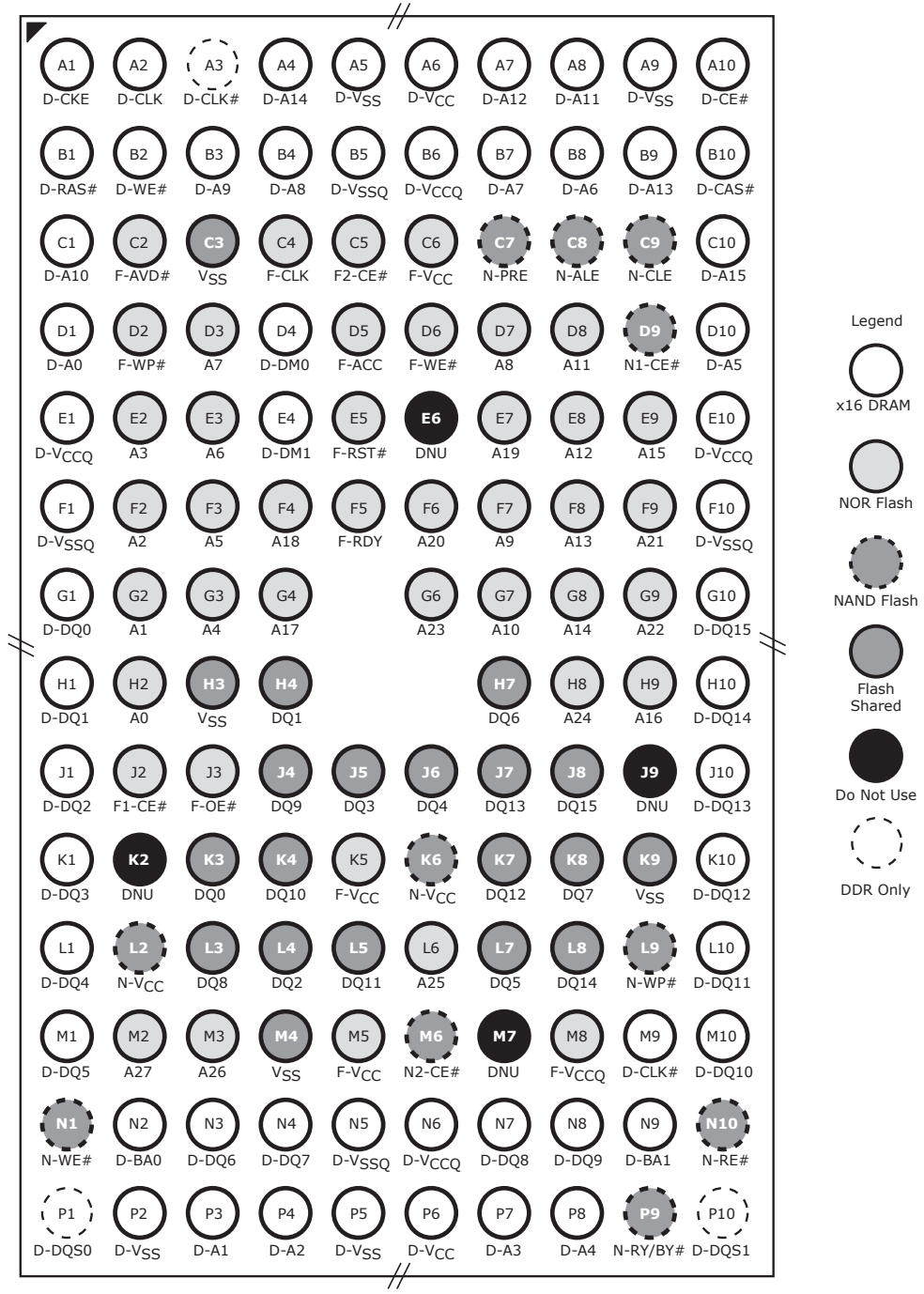

3.8 NOR Flash and DRAM Input/Output Descriptions

A23-A0	=	NOR Flash Address inputs
DQ15-DQ0	=	Flash Data input/output, shared between NOR and ORNAND Flash. DQ0-DQ7 shared for x8 ORNAND
F2-CE#	=	NOR Flash Chip-enable input # 2. Asynchronous relative to CLK for burst mode.
F1-CE#	=	NOR Flash Chip-enable input #1. Asynchronous relative to CLK for Burst Mode.
OE#	=	NOR Flash Output Enable input. Asynchronous relative to CLK for Burst mode.
F-WE#	=	NOR Flash Write Enable input.
F-VCC	=	NOR Flash device power supply (1.7 V - 1.95V).
F-VCCQ	=	Input/Output Buffer power supply.
V _{SS}	=	Ground
RFU	=	Reserved for Future Use
RDY	=	Flash ready output. Indicates the status of the Burst read. VOL = data valid. Shared between NOR and ORNAND Flash.
CLK	=	NOR Flash Clock. The first rising edge of CLK in conjunction with AVD# low latches the address input and activates burst mode operation. After the initial word is output, subsequent rising edges of CLK increment the internal address counter. CLK should remain low during asynchronous access.
AVD#	=	NOR Flash Address Valid input. Indicates to device that the valid address is present on the address inputs. VIL = for asynchronous mode, indicates valid address; for burst mode, causes starting address to be latched on rising edge of CLK. VIH= device ignores address inputs
F-RST#	=	NOR Flash hardware reset input. VIL= device resets and returns to reading array data
F-WP#	=	NOR Flash hardware write protect input. VIL = disables program and erase functions in the four outermost sectors.
F-ACC	=	NOR Flash accelerated input. At VHH, accelerates programming; automatically places device in unlock bypass mode. At VIL, disables all program and erase functions. Should be at VIH for all other conditions.
D-A12-D-A0	=	SDRAM Address inputs
D-DQ15-D-DQ0	=	SDRAM Data input/output
D-CLK	=	SDRAM System Clock
D-CE#	=	SDRAM Chip Select
D-CKE	=	SDRAM Clock Enable
D-BA1-BA0	=	SDRAM Bank Select
D-RAS#	=	SDRAM Row Address Strobe
D-CAS#	=	SDRAM Column Address Strobe
D-DM1-D-DM0	=	SDRAM Data Input/Output Mask
D-WE#	=	SDRAM Write Enable input
D-VSS	=	SDRAM Ground
D-VSSQ	=	SDRAM Input/Output Buffer ground
D-VCCQ	=	SDRAM Input/Output Buffer power supply
D-VCC	=	SDRAM device power supply

3.8.1 ORNAND Signal Descriptions

N-PRE	=	ORNAND Power-On Read Enable. Tie to VSS on customer board if not used
N-ALE	=	ORNAND Address Latch Enable
N-CLE	=	ORNAND Command Latch Enable
N-CE#	=	ORNAND Chip-enable
N-WP#	=	ORNAND Write-protect
N-WE#	=	ORNAND Write-enable
N-RE#	=	ORNAND Read-enable
N-RY/BY#	=	ORNAND Ready-Busy—this is shared with NOR RDY
N-I/O0-N-I/O15	=	ORNAND I/O Signals (I/O0-I/O7 for x8 bus width)
N-VCC	=	ORNAND Power Supply

4 Ordering Information

The order number is formed by a valid combinations of the following:

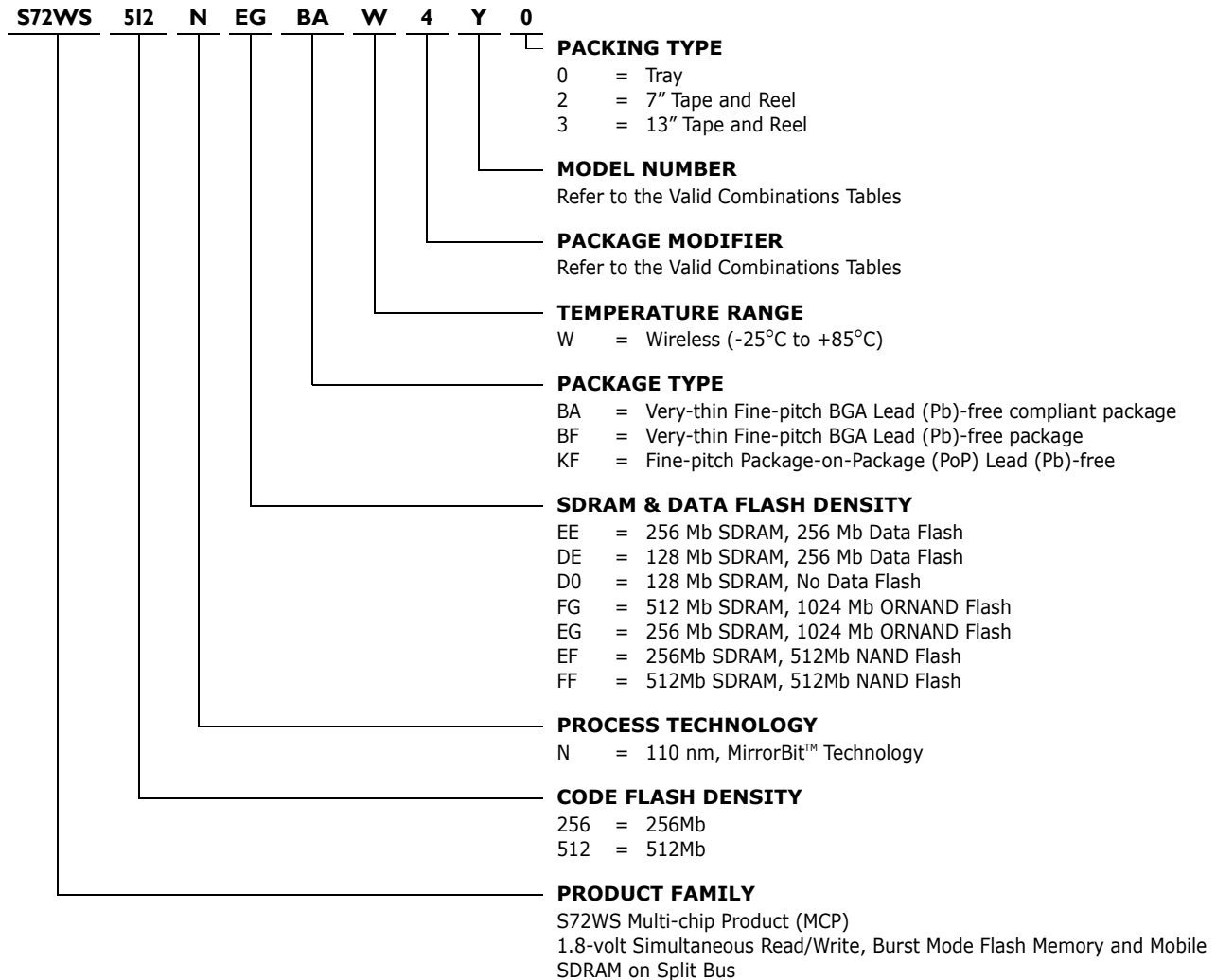

S72WS256ND0 Valid Combinations				NOR Flash Burst Speed	SDRAM Supplier	SDRAM Burst Speed	Package Type	Package Marking
Base Ordering Part Number	Package & Temperature	Model Number	Packing Type					
S72WS256ND0	BFW	93	0, 2, 3 (Note 1)	66 MHz	Supplier 5	133 MHz	9x12x1.2mm 137-ball	(Note 2)I
	BAW, BFW	B7		54 MHz	Supplier 1	104 MHz		
		BB		Supplier 2				
	KFW	D3		66 MHz	Supplier 5	133 MHz	15x15x1.25mm 160-ball	

S72WS256NDE Valid Combinations				NOR Flash Burst Speed	SDRAM Supplier	SDRAM Burst Speed	Package Type	Package Marking
Base Ordering Part Number	Package & Temperature	Model Number	Packing Type					
S72WS256NDE	BAW, BFW	U7	0, 2, 3 (Note 1)	54 MHz	Supplier 1	104 MHz	9x12x1.4mm 137-ball	(Note 2)
		UB			Supplier 2			

S72WS256NEE Valid Combinations				Flash Burst Speed	SDRAM Supplier	SDRAM Burst Speed	Package Type	Package Marking
Base Ordering Part Number	Package & Temperature	Model Number	Packing Type					
S72WS256NEE	BAW, BFW	U7	0, 2, 3 (Note 1)	54 MHz	Supplier 1	104 MHz	9x12x1.4mm 137-ball	(Note 2)
		UB			Supplier 2			

S72WS512NFF Valid Combinations				Flash Speed	DRAM Supplier	DRAM Speed	Package	Package Marking
Base Ordering Part Number	Package & Temperature	Model Number	Packing Type					
S72WS512NFF	BAW, BFW	ZJ	0, 2, 3 (Note 1)	66 MHz	DRAM Type 1	133 MHz	11 x 13 mm 137-ball	(Note 2)
	KFW						15 x 15 5mm 160-ball	
	BAW, BFW	Z2			DRAM Type 5		11 x 13 mm 137-ball	
	KFW				15 x 15 5mm 160-ball			
	BAW, BFW	ZT			DRAM Type 2		11 x 13 mm 137-ball	
	KFW						15 x 15 5mm 160-ball	

S72WS512NFG Valid Combinations				Flash Burst Speed	SDRAM Supplier	SDRAM Burst Speed	Package Type	Package Marking
Base Ordering Part Number	Package & Temperature	Model Number	Packing Type					
S72WS512NFG	BAW, BFW	L7	0, 2, 3 (Note 1)	54 MHz	DRAM Type 4	104 MHz	11x13x1.4mm 137-ball	(Note 2)
		L6						
		L5						
		47						
		46						
		45			DRAM Type 2			
		LZ						
		LY						
		LW						
		4Z						
		4Y			DRAM Type 4			
		4W						
		N7						
		N6						
		N5						
		67						
		66						
		65						
		NZ						
		NY			DRAM Type 2			
NW								
6Z								
6Y								
6W								

S72WS512NEG Valid Combinations				Flash Burst Speed	SDRAM Supplier	SDRAM Burst Speed	Package Type	Package Marking
Base Ordering Part Number	Package & Temperature	Model Number	Packing Type					
S72WS512NEG	BAW, BFW	LZ	0, 2, 3 (Note 1)	54 MHz	DRAM Type 2	104 MHz	11x13.1x1.4mm 137-ball	(Note 2)
		LY						
		LW						
		4Z						
		4Y						
		4W						
		NZ						
		NY						
		NW						
		6Z						
		6Y						
		6W						

S72WS512NEF Valid Combinations				Flash Burst Speed	SDRAM Supplier	SDRAM Burst Speed	Package Type	Package Marking
Base Ordering Part Number	Package & Temperature	Model Number	Packing Type					
S72WS512NEF	KFW	HJ	0, 2, 3 (Note 1)	66 MHz	DRAM Type 2	133 MHz	15x15x1.2 mm 160-ball	(Note 2)

Notes:

1. Packing Type 0 is standard. Specify other options as required.
2. BGA package marking omits leading "S" and packing type designator from ordering part number.

Valid Combinations

Valid Combinations list configurations planned to be supported in volume for this device. Consult your local sales office to confirm availability of specific valid combinations and to check on newly released combinations.

5 Physical Dimensions

5.1 TLDI37—I37-ball Fine-Pitch Ball Grid Array (FBGA) 12 x 9 mm Package

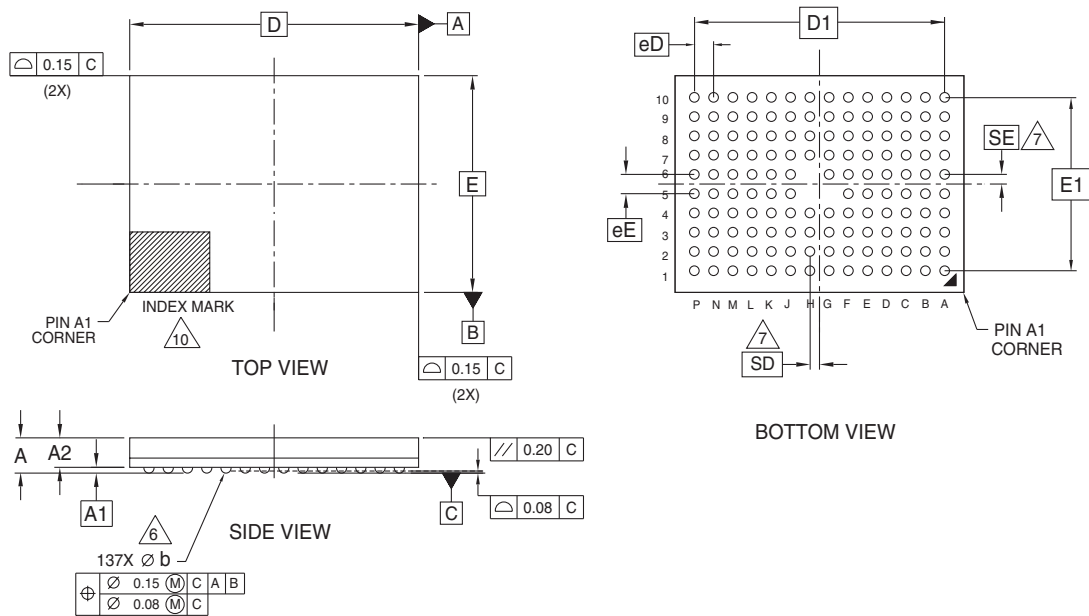

PACKAGE	TLD 137			NOTE
JEDEC	N/A			
D x E	12.00 mm x 9.00 mm PACKAGE			
SYMBOL	MIN	NOM	MAX	
A	---	---	1.20	PROFILE
A1	0.17	---	---	BALL HEIGHT
A2	0.81	---	0.97	BODY THICKNESS
D	12.00 BSC.			BODY SIZE
E	9.00 BSC.			BODY SIZE
D1	10.40 BSC.			MATRIX FOOTPRINT
E1	7.20 BSC.			MATRIX FOOTPRINT
MD	14			MATRIX SIZE D DIRECTION
ME	10			MATRIX SIZE E DIRECTION
n	137			BALL COUNT
ϕb	0.35	0.40	0.45	BALL DIAMETER
eE	0.80 BSC.			BALL PITCH
eD	0.80 BSC.			BALL PITCH
SD / SE	0.40 BSC.			SOLDER BALL PLACEMENT
	G5,H5,H6			DEPOPULATED SOLDER BALLS

NOTES:

- DIMENSIONING AND TOLERANCING METHODS PER ASME Y14.5M-1994.
- ALL DIMENSIONS ARE IN MILLIMETERS.
- BALL POSITION DESIGNATION PER JESD 95-1, SPP-010.
- [e] REPRESENTS THE SOLDER BALL GRID PITCH.
- SYMBOL "MD" IS THE BALL MATRIX SIZE IN THE "D" DIRECTION.
SYMBOL "ME" IS THE BALL MATRIX SIZE IN THE "E" DIRECTION.
n IS THE NUMBER OF POPULATED SOLDER BALL POSITIONS FOR MATRIX SIZE MD X ME.
- DIMENSION "b" IS MEASURED AT THE MAXIMUM BALL DIAMETER IN A PLANE PARALLEL TO DATUM C.
- SD AND SE ARE MEASURED WITH RESPECT TO DATUMS A AND B AND DEFINE THE POSITION OF THE CENTER SOLDER BALL IN THE OUTER ROW.
- WHEN THERE IS AN ODD NUMBER OF SOLDER BALLS IN THE OUTER ROW SD OR SE = 0.000.
- WHEN THERE IS AN EVEN NUMBER OF SOLDER BALLS IN THE OUTER ROW, SD OR SE = [e/2]
- "+" INDICATES THE THEORETICAL CENTER OF DEPOPULATED BALLS.
- N/A
- A1 CORNER TO BE IDENTIFIED BY CHAMFER, LASER OR INK MARK, METALLIZED MARK INDENTATION OR OTHER MEANS.

3393; 16-038;22a

5.2 FEA137—I37-ball Fine-Pitch Ball Grid Array (FBGA) 13 x 11 mm Package

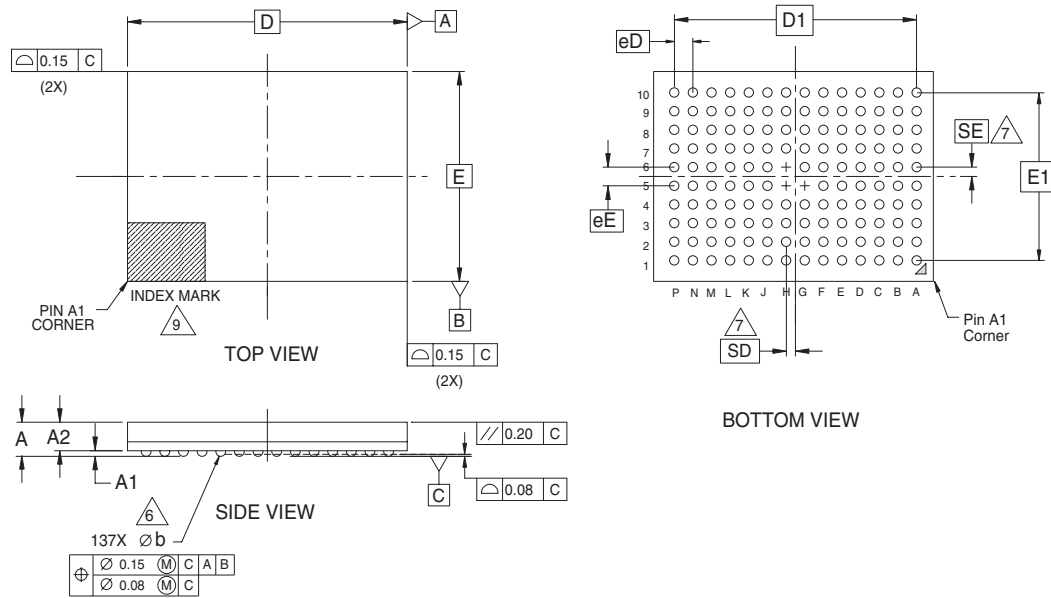

NOTES:

- DIMENSIONING AND TOLERANCING METHODS PER ASME Y14.5M-1994.
 - ALL DIMENSIONS ARE IN MILLIMETERS.
 - BALL POSITION DESIGNATION PER JEP95, SECTION 4.3, SPP-010.
 - \boxed{e} REPRESENTS THE SOLDER BALL GRID PITCH.
 - SYMBOL "MD" IS THE BALL MATRIX SIZE IN THE "D" DIRECTION.
SYMBOL "ME" IS THE BALL MATRIX SIZE IN THE "E" DIRECTION.
n IS THE NUMBER OF POPULATED SOLDER BALL POSITIONS FOR MATRIX SIZE MD X ME.
- $\triangle 6$ DIMENSION "b" IS MEASURED AT THE MAXIMUM BALL DIAMETER IN A PLANE PARALLEL TO DATUM C.
- $\triangle 7$ SD AND SE ARE MEASURED WITH RESPECT TO DATUMS A AND B AND DEFINE THE POSITION OF THE CENTER SOLDER BALL IN THE OUTER ROW.
- WHEN THERE IS AN ODD NUMBER OF SOLDER BALLS IN THE OUTER ROW SD OR SE = 0.000.
- WHEN THERE IS AN EVEN NUMBER OF SOLDER BALLS IN THE OUTER ROW, SD OR SE = $\frac{e}{2}$
- *+ INDICATES THE THEORETICAL CENTER OF DEPOPULATED BALLS.
 - $\triangle 9$ A1 CORNER TO BE IDENTIFIED BY CHAMFER, LASER OR INK MARK, METALLIZED MARK INDENTATION OR OTHER MEANS.

PACKAGE	FEA 137			NOTE
JEDEC	N/A			
D X E	12.00mm X 9.00mm PACKAGE			
SYMBOL	MIN.	NOM.	MAX.	
A	-	-	1.40	PROFILE
A1	0.10	-	-	BALL HEIGHT
A2	1.11	-	1.26	BODY THICKNESS
\boxed{D}	12.00 BSC			BODY SIZE
\boxed{E}	9.00 BSC			BODY SIZE
$\boxed{D1}$	10.40 BSC			MATRIX FOOTPRINT
$\boxed{\quad}$	7.20 BSC			MATRIX FOOTPRINT
MD	14			MATRIX SIZE D DIRECTION
ME	10			MATRIX SIZE E DIRECTION
n	1.37			BALL COUNT
$\varnothing b$	0.35	0.40	0.45	BALL DIAMETER
\boxed{eE}	0.80 BSC			BALL PITCH
\boxed{eD}	0.80 BSC			BALL PITCH
SD/SE	0.40 BSC			SOLDER BALL PLACEMENT
	G5, H5, H8			DEPOPULATED SOLDER BALLS

5.3 FVDI37—I37-ball Fine-Pitch Ball Grid Array (FBGA) II x I3 mm Package

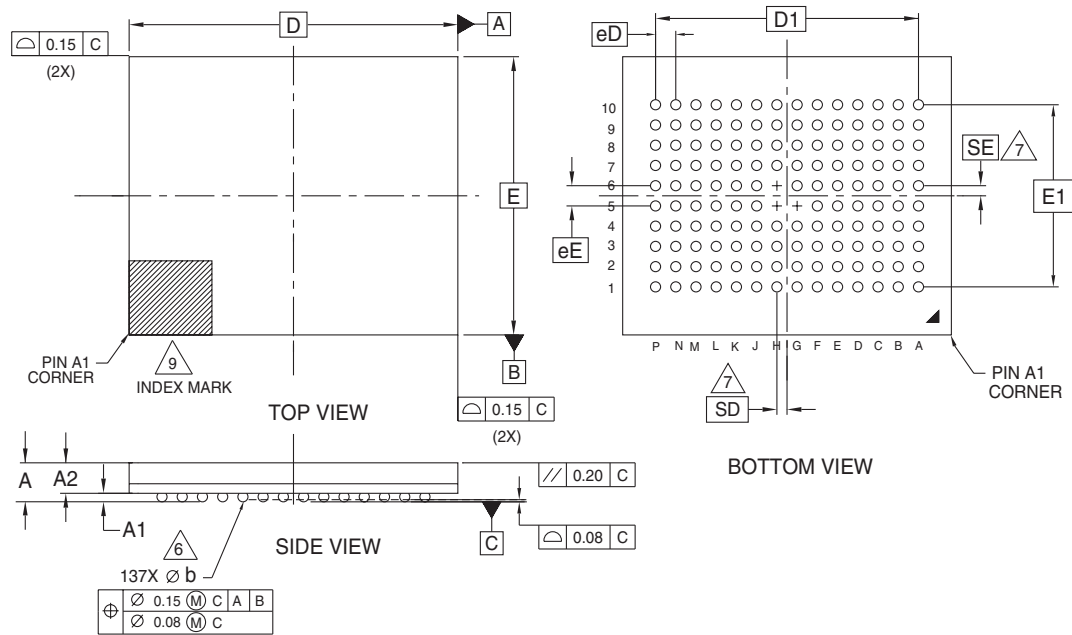

PACKAGE	FVD 137			NOTE
JEDEC	N/A			
D x E	13.00 mm x 11.00 mm PACKAGE			
SYMBOL	MIN	NOM	MAX	
A	---	---	1.40	PROFILE
A1	0.10	---	---	BALL HEIGHT
A2	1.09	---	1.24	BODY THICKNESS
D	13.00 BSC.			BODY SIZE
E	11.00 BSC.			BODY SIZE
D1	10.40 BSC.			MATRIX FOOTPRINT
E1	7.20 BSC.			MATRIX FOOTPRINT
MD	14			MATRIX SIZE D DIRECTION
ME	10			MATRIX SIZE E DIRECTION
n	137			BALL COUNT
Øb	0.35	0.40	0.45	BALL DIAMETER
eE	0.80 BSC.			BALL PITCH
eD	0.80 BSC.			BALL PITCH
SD SE	0.40 BSC.			SOLDER BALL PLACEMENT
	G5,H5,H6			DEPOPULATED SOLDER BALLS

NOTES:

- DIMENSIONING AND TOLERANCING METHODS PER ASME Y14.5M-1994.
- ALL DIMENSIONS ARE IN MILLIMETERS.
- BALL POSITION DESIGNATION PER JEP95, SECTION 4.3, SPP-010.
- [e] REPRESENTS THE SOLDER BALL GRID PITCH.
- SYMBOL "MD" IS THE BALL MATRIX SIZE IN THE "D" DIRECTION.
SYMBOL "ME" IS THE BALL MATRIX SIZE IN THE "E" DIRECTION.
n IS THE NUMBER OF POPULATED SOLDER BALL POSITIONS FOR MATRIX SIZE MD X ME.
- [6] DIMENSION "b" IS MEASURED AT THE MAXIMUM BALL DIAMETER IN A PLANE PARALLEL TO DATUM C.
- [7] SD AND SE ARE MEASURED WITH RESPECT TO DATUMS A AND B AND DEFINE THE POSITION OF THE CENTER SOLDER BALL IN THE OUTER ROW.
WHEN THERE IS AN ODD NUMBER OF SOLDER BALLS IN THE OUTER ROW SD OR SE = 0.000.
WHEN THERE IS AN EVEN NUMBER OF SOLDER BALLS IN THE OUTER ROW, SD OR SE = [e/2]
- *+ INDICATES THE THEORETICAL CENTER OF DEPOPULATED BALLS.
- [9] A1 CORNER TO BE IDENTIFIED BY CHAMFER, LASER OR INK MARK, METALLIZED MARK INDENTATION OR OTHER MEANS.

3522 \ 16-038.21 \ 09.29.05

5.4 BWA160—160-ball Fine-Pitch Ball Grid Array (FBGA) 15 x 15 mm Package

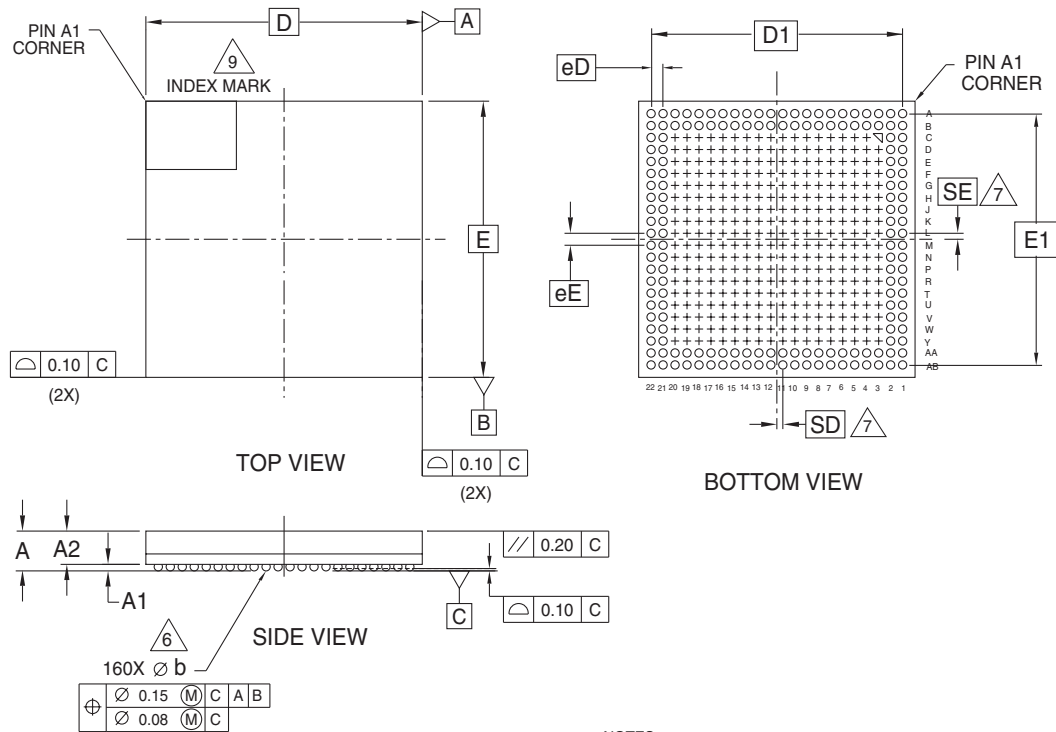

PACKAGE	BWA 160			NOTE
JEDEC	N/A			
D x E	15.00 mm x 15.00 mm PACKAGE			
SYMBOL	MIN	NOM	MAX	
A	---	---	1.25	PROFILE
A1	0.35	---	---	BALL HEIGHT
A2	0.74	---	0.84	BODY THICKNESS
D	15.00 BSC.			BODY SIZE
E	15.00 BSC.			BODY SIZE
D1	13.65 BSC.			MATRIX FOOTPRINT
E1	13.65 BSC.			MATRIX FOOTPRINT
MD	22			MATRIX SIZE D DIRECTION
ME	22			MATRIX SIZE E DIRECTION
n	160			BALL COUNT
N	160			MAXIMUM NUMBER OF BALLS
R	2			NUMBER OF LAND PARAMETERS
Øb	0.40	0.45	0.50	BALL DIAMETER
eE	0.65 BSC.			BALL PITCH
eD	0.65 BSC.			BALL PITCH
SD SE	0.325 BSC.			SOLDER BALL PLACEMENT
	C3-C20,D3-D20,E3-E20,F3-F20 G3-G20,H3-H20,J3-J20,K3-K20 L3-L20,M3-M20,N3-N20,P3-P20 R3-R20,T3-T20,U3-U20,V3-V20 W3-W20,Y3-Y20			DEPOPULATED SOLDER BALLS

NOTES:

- DIMENSIONING AND TOLERANCING METHODS PER ASME Y14.5M-1994.
- ALL DIMENSIONS ARE IN MILLIMETERS.
- BALL POSITION DESIGNATION PER JEP95, SECTION 4.3, SPP-010.
- [e] REPRESENTS THE SOLDER BALL GRID PITCH.
- SYMBOL "MD" IS THE BALL MATRIX SIZE IN THE "D" DIRECTION.
SYMBOL "ME" IS THE BALL MATRIX SIZE IN THE "E" DIRECTION.
n IS THE NUMBER OF POPULATED SOLDER BALL POSITIONS FOR MATRIX SIZE MD X ME.
- [6] DIMENSION "b" IS MEASURED AT THE MAXIMUM BALL DIAMETER IN A PLANE PARALLEL TO DATUM C.
- [7] SD AND SE ARE MEASURED WITH RESPECT TO DATUMS A AND B AND DEFINE THE POSITION OF THE CENTER SOLDER BALL IN THE OUTER ROW.
WHEN THERE IS AN ODD NUMBER OF SOLDER BALLS IN THE OUTER ROW SD OR SE = 0.000.
WHEN THERE IS AN EVEN NUMBER OF SOLDER BALLS IN THE OUTER ROW, SD OR SE = [e/2]
- "+" INDICATES THE THEORETICAL CENTER OF DEPOPULATED BALLS.
- [9] A1 CORNER TO BE IDENTIFIED BY CHAMFER, LASER OR INK MARK, METALLIZED MARK INDENTATION OR OTHER MEANS.
10. OUTLINE AND DIMENSIONS PER CUSTOMER REQUIREMENT.

3518 \ 16-038.46 \ 02.23.06

5.5 BWBI60—I60-ball Fine-Pitch Ball Grid Array (FBGA) I5 x I5 mm Package

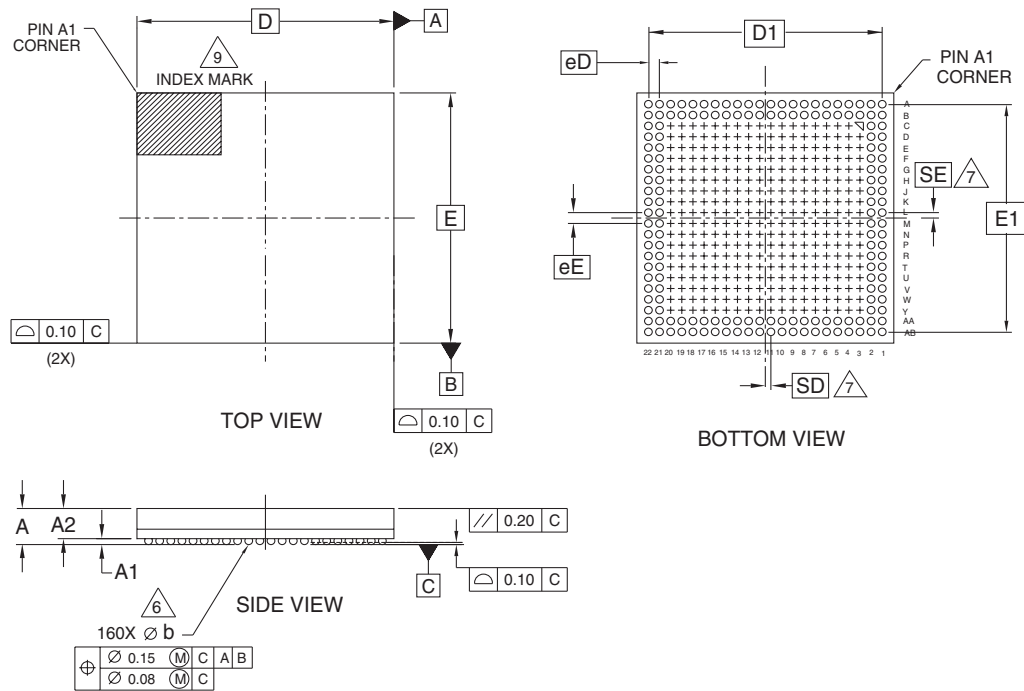

NOTES:

1. DIMENSIONING AND TOLERANCING METHODS PER ASME Y14.5M-1994.
2. ALL DIMENSIONS ARE IN MILLIMETERS.
3. BALL POSITION DESIGNATION PER JEP95, SECTION 4.3, SPP-010.
4. [e] REPRESENTS THE SOLDER BALL GRID PITCH.
5. SYMBOL "MD" IS THE BALL MATRIX SIZE IN THE "D" DIRECTION.
SYMBOL "ME" IS THE BALL MATRIX SIZE IN THE "E" DIRECTION.
n IS THE NUMBER OF POPULATED SOLDER BALL POSITIONS FOR MATRIX SIZE MD X ME.
6. DIMENSION "b" IS MEASURED AT THE MAXIMUM BALL DIAMETER IN A PLANE PARALLEL TO DATUM C.
7. SD AND SE ARE MEASURED WITH RESPECT TO DATUMS A AND B AND DEFINE THE POSITION OF THE CENTER SOLDER BALL IN THE OUTER ROW.
WHEN THERE IS AN ODD NUMBER OF SOLDER BALLS IN THE OUTER ROW SD OR SE = 0.000.
WHEN THERE IS AN EVEN NUMBER OF SOLDER BALLS IN THE OUTER ROW, SD OR SE = [e/2]
8. "+" INDICATES THE THEORETICAL CENTER OF DEPOPULATED BALLS.
9. A1 CORNER TO BE IDENTIFIED BY CHAMFER, LASER OR INK MARK, METALLIZED MARK INDENTATION OR OTHER MEANS.
10. OUTLINE AND DIMENSIONS PER CUSTOMER REQUIREMENT.

PACKAGE	BWB 160			NOTE
JEDEC	N/A			
D x E	15.00 mm x 15.00 mm PACKAGE			
SYMBOL	MIN	NOM	MAX	
A	---	---	1.30	PROFILE
A1	0.40	---	---	BALL HEIGHT
A2	0.74	---	0.84	BODY THICKNESS
D	15.00 BSC.			BODY SIZE
E	15.00 BSC.			BODY SIZE
D1	13.65 BSC.			MATRIX FOOTPRINT
E1	13.65 BSC.			MATRIX FOOTPRINT
MD	22			MATRIX SIZE D DIRECTION
ME	22			MATRIX SIZE E DIRECTION
n	160			BALL COUNT
N	160			MAXIMUM NUMBER OF BALLS
R	2			NUMBER OF LAND PARAMETERS
Øb	0.45	0.50	0.55	BALL DIAMETER
eE	0.65 BSC.			BALL PITCH
eD	0.65 BSC.			BALL PITCH
SD / SE	0.325 BSC.			SOLDER BALL PLACEMENT
	C3-C20,D3-D20,E3-E20,F3-F20 G3-G20,H3-H20,J3-J20,K3-K20 L3-L20,M3-M20,N3-N20,P3-P20 R3-R20,T3-T20,U3-U20,V3-V20 W3-W20,Y3-Y20			DEPOPULATED SOLDER BALLS

3523 | 16-038-46 | 02.23.06

5.6 BTA160—160-ball Fine-Pitch Ball Grid Array (FBGA) 15 x 15 mm Package

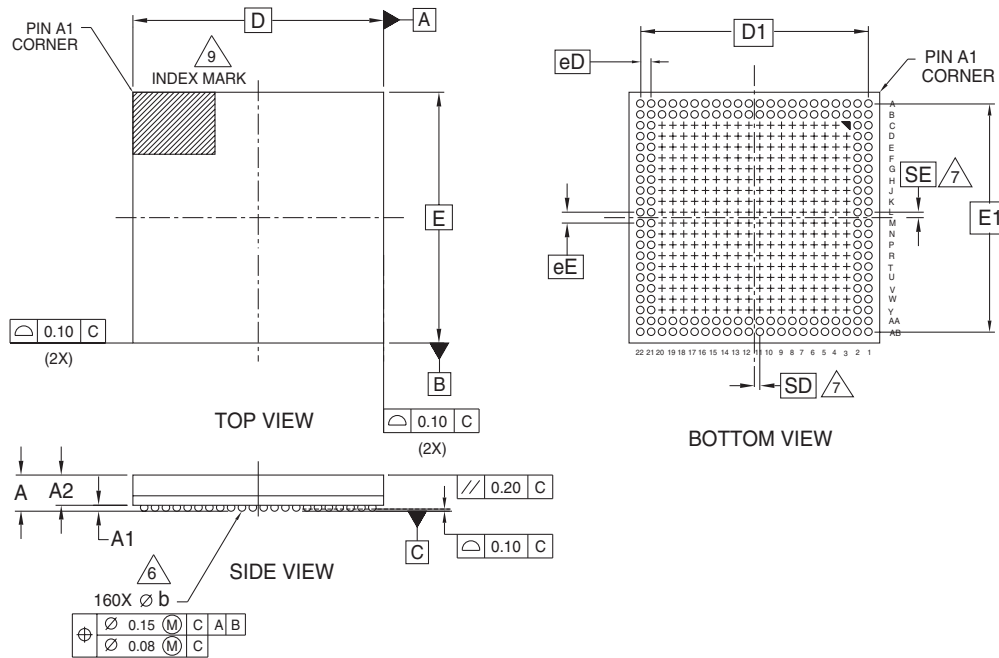

NOTES:

1. DIMENSIONING AND TOLERANCING METHODS PER ASME Y14.5M-1994.
2. ALL DIMENSIONS ARE IN MILLIMETERS.
3. BALL POSITION DESIGNATION PER JEP95, SECTION 4.3, SPP-010.
4. [e] REPRESENTS THE SOLDER BALL GRID PITCH.
5. SYMBOL "MD" IS THE BALL MATRIX SIZE IN THE "D" DIRECTION.
SYMBOL "ME" IS THE BALL MATRIX SIZE IN THE "E" DIRECTION.
n IS THE NUMBER OF POPULATED SOLDER BALL POSITIONS FOR MATRIX SIZE MD X ME.
6. DIMENSION "b" IS MEASURED AT THE MAXIMUM BALL DIAMETER IN A PLANE PARALLEL TO DATUM C.
7. SD AND SE ARE MEASURED WITH RESPECT TO DATUMS A AND B AND DEFINE THE POSITION OF THE CENTER SOLDER BALL IN THE OUTER ROW.
WHEN THERE IS AN ODD NUMBER OF SOLDER BALLS IN THE OUTER ROW, SD OR SE = 0.000.
WHEN THERE IS AN EVEN NUMBER OF SOLDER BALLS IN THE OUTER ROW, SD OR SE = [e/2]
8. "+" INDICATES THE THEORETICAL CENTER OF DEPOPULATED BALLS.
9. A1 CORNER TO BE IDENTIFIED BY CHAMFER, LASER OR INK MARK, METALLIZED MARK INDENTATION OR OTHER MEANS.
10. OUTLINE AND DIMENSIONS PER CUSTOMER REQUIREMENT.

PACKAGE	BTA 160			NOTE
JEDEC	N/A			
D x E	15.00 mm x 15.00 mm PACKAGE			
SYMBOL	MIN	NOM	MAX	
A	---	---	1.30	PROFILE
A1	0.40	---	---	BALL HEIGHT
A2	0.74	---	0.84	BODY THICKNESS
[D]	15.00 BSC.			BODY SIZE
[E]	15.00 BSC.			BODY SIZE
[D1]	13.65 BSC.			MATRIX FOOTPRINT
[E1]	13.65 BSC.			MATRIX FOOTPRINT
MD	22			MATRIX SIZE D DIRECTION
ME	22			MATRIX SIZE E DIRECTION
n	160			BALL COUNT
N	160			MAXIMUM NUMBER OF BALLS
R	2			NUMBER OF LAND PARAMETERS
\varnothing b	0.45	0.50	0.55	BALL DIAMETER
[eE]	0.65 BSC.			BALL PITCH
[eD]	0.65 BSC.			BALL PITCH
[SD][SE]	0.325 BSC.			SOLDER BALL PLACEMENT
	C3-C20,D3-D20,E3-E20,F3-F20,G3-G20,H3-H20,J3-J20,K3-K20,L3-L20,M3-M20,N3-N20,P3-P20,R3-R20,T3-T20,U3-U20,V3-V20,W3-W20,Y3-Y20			DEPOPULATED SOLDER BALLS

3550 \ 16-038.55 \ 02.23.06

5.7 ALH160—160-ball Fine-Pitch Ball Grid Array (FBGA) 15 x 15 mm Package

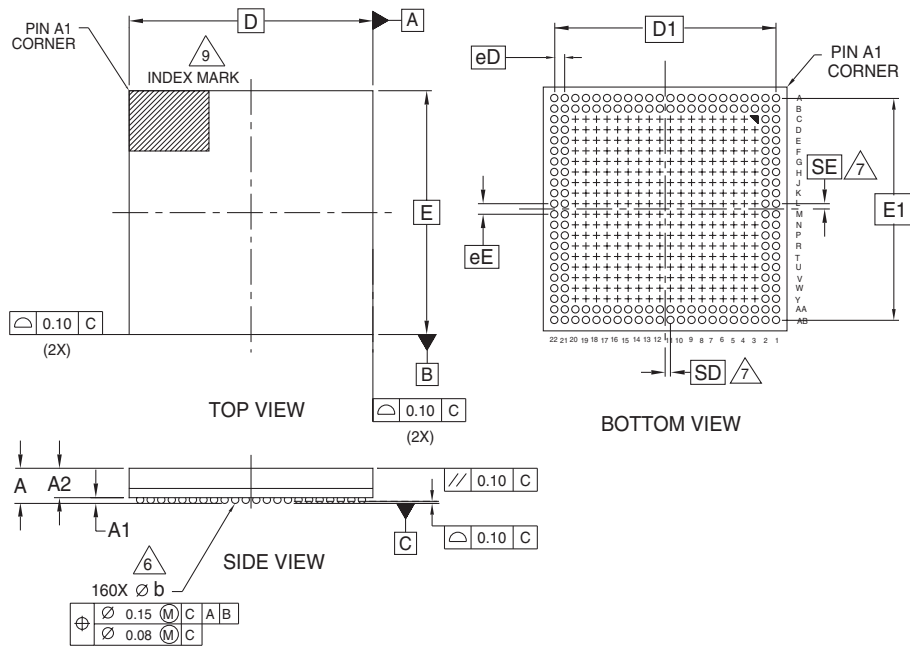

PACKAGE	ALH 160			
JEDEC	N/A			
D x E	15.00 mm x 15.00 mm PACKAGE			
SYMBOL	MIN	NOM	MAX	NOTE
A	---	---	1.10	PROFILE
A1	0.40	---	---	BALL HEIGHT
A2	0.53	---	0.65	BODY THICKNESS
D	15.00 BSC.			BODY SIZE
E	15.00 BSC.			BODY SIZE
D1	13.65 BSC.			MATRIX FOOTPRINT
E1	13.65 BSC.			MATRIX FOOTPRINT
MD	22			MATRIX SIZE D DIRECTION
ME	22			MATRIX SIZE E DIRECTION
n	160			BALL COUNT
N	160			MAXIMUM NUMBER OF BALLS
R	2			NUMBER OF LAND PERIMETERS
Øb	0.45	0.50	0.55	BALL DIAMETER
eE	0.65 BSC.			BALL PITCH
eD	0.65 BSC.			BALL PITCH
SE SD	0.325 BSC.			SOLDER BALL PLACEMENT
	C3-C20, D3-D20, E3-E20, F3-F20, G3-G20, H3-H20, J3-J20, K3-K20, L3-L20, M3-M20, N3-N20, P3-P20, R3-R20, T3-T20, U3-U20, V3-V20, W3-W20, Y3-Y20			DEPOPULATED SOLDER BALLS

NOTES:

- DIMENSIONING AND TOLERANCING METHODS PER ASME Y14.5M-1994.
- ALL DIMENSIONS ARE IN MILLIMETERS.
- BALL POSITION DESIGNATION PER JEP95, SECTION 4.3, SPP-010.
- [e] REPRESENTS THE SOLDER BALL GRID PITCH.
- SYMBOL "MD" IS THE BALL MATRIX SIZE IN THE "D" DIRECTION.
SYMBOL "ME" IS THE BALL MATRIX SIZE IN THE "E" DIRECTION.
n IS THE NUMBER OF POPULATED SOLDER BALL POSITIONS FOR MATRIX SIZE MD X ME.
- ⚠ DIMENSION "b" IS MEASURED AT THE MAXIMUM BALL DIAMETER IN A PLANE PARALLEL TO DATUM C.

⚠ SD AND SE ARE MEASURED WITH RESPECT TO DATUMS A AND B AND DEFINE THE POSITION OF THE CENTER SOLDER BALL IN THE OUTER ROW.

WHEN THERE IS AN ODD NUMBER OF SOLDER BALLS IN THE OUTER ROW SD OR SE = 0.000.

WHEN THERE IS AN EVEN NUMBER OF SOLDER BALLS IN THE OUTER ROW, SD OR SE = [e/2]
- "+" INDICATES THE THEORETICAL CENTER OF DEPOPULATED BALLS.
- A1 CORNER TO BE IDENTIFIED BY CHAMFER, LASER OR INK MARK, METALLIZED MARK INDENTATION OR OTHER MEANS.

3553 \ 16-038.24 \ 3.21.06

6 MCP Revision Summary

Revision A (August 26, 2004)

Initial release

Revision A I (June 1, 2005)

Added SDRAM Type 2 module

Added Lead (Pb)-free options

Added FEA137 package diagram

Revision A2 (October 7, 2005)

Global

Updated the S29WS-N NOR Flash Module

Added the S30MS-P ORNAND Flash Module

Added SDRAM Type 4 module

Product Selector Guide

Updated the Product Selector Guide

Connection Diagrams

Added two diagrams for the x8 and x16 ORNAND connections

Pin Descriptions

Updated descriptions and added descriptions for ORNAND signals

Ordering Information

Added new options

Added Package-on-Package (PoP) options

Valid Combinations

Updated the valid combinations tables

Physical Dimensions

Added the FGA137 package diagram

Added the BWA160 package diagram

Added the BWB160 package diagram

Revision A3 (November 9, 2005)

Updated the SDRAM Type 1 module

Changed the status of all RAM modules to Preliminary from Advanced.

Revision A4 (December 14, 2005)

Product Selector Guides

Updated the tables

Connection Diagrams

Added the 512 Mb NOR Flash with 512 Mb NAND on Bus 1 and 512 Mb SDRAM on Bus 2 diagram

Ordering Information

Added new model number, package modifier and SDRAM & Data Flash density options

Valid Combinations

Updated all tables with new options

Revision A5 (December 16, 2005)**Connection Diagrams**

Updated the pinouts to include DDR signals

Qualified 133 MHz as DDR based frequency

Revision A6 (March 21, 2006)**NOR Flash + ORNAND Flash + DRAM MCPs Product Selector Guide**

Updated the model numbers

Ordering Information Table

Updated the table

Valid Combinations

Updated the tables

Physical Dimensions

Added the ALH160 package

Revision A7 (April 18, 2006)**Connection Diagrams**

Updated the pinouts

Revision A8 (June 1, 2006)

Added 2 OPNs for products with DRAM Type 5

Updated product selector guide

Updated valid combination table

Added BTA160 package diagram

Colophon

The products described in this document are designed, developed and manufactured as contemplated for general use, including without limitation, ordinary industrial use, general office use, personal use, and household use, but are not designed, developed and manufactured as contemplated (1) for any use that includes fatal risks or dangers that, unless extremely high safety is secured, could have a serious effect to the public, and could lead directly to death, personal injury, severe physical damage or other loss (i.e., nuclear reaction control in nuclear facility, aircraft flight control, air traffic control, mass transport control, medical life support system, missile launch control in weapon system), or (2) for any use where chance of failure is intolerable (i.e., submersible repeater and artificial satellite). Please note that Spansion LLC will not be liable to you and/or any third party for any claims or damages arising in connection with above-mentioned uses of the products. Any semiconductor devices have an inherent chance of failure. You must protect against injury, damage or loss from such failures by incorporating safety design measures into your facility and equipment such as redundancy, fire protection, and prevention of over-current levels and other abnormal operating conditions. If any products described in this document represent goods or technologies subject to certain restrictions on export under the Foreign Exchange and Foreign Trade Law of Japan, the US Export Administration Regulations or the applicable laws of any other country, the prior authorization by the respective government entity will be required for export of those products.

Trademarks and Notice

The contents of this document are subject to change without notice. This document may contain information on a Spansion LLC product under development by Spansion LLC. Spansion LLC reserves the right to change or discontinue work on any product without notice. The information in this document is provided as is without warranty or guarantee of any kind as to its accuracy, completeness, operability, fitness for particular purpose, merchantability, non-infringement of third-party rights, or any other warranty, express, implied, or statutory. Spansion LLC assumes no liability for any damages of any kind arising out of the use of the information in this document.

Copyright ©2004-2006 Spansion LLC. All rights reserved. Spansion, the Spansion logo, MirrorBit, ORNAND, HD-SIM, and combinations thereof are trademarks of Spansion LLC. Other names are for informational purposes only and may be trademarks of their respective owners.