

# 36Mb DDRII+ CIO BL2 w/ ODT SRAM Specification (2.5 Clock Read Latency)

165FBGA with Pb & Pb Free  
(ROHS Compliant)

**INFORMATION IN THIS DOCUMENT IS PROVIDED IN RELATION TO NETSOL PRODUCTS,  
AND IS SUBJECT TO CHANGE WITHOUT NOTICE.**

**NOTHING IN THIS DOCUMENT SHALL BE CONSTRUED AS GRANTING ANY LICENSE,  
EXPRESS OR IMPLIED, BY ESTOPPEL OR OTHERWISE,**

**TO ANY INTELLECTUAL PROPERTY RIGHTS IN NETSOL PRODUCTS OR TECHNOLOGY.  
ALL INFORMATION IN THIS DOCUMENT IS PROVIDED**

**ON AS "AS IS" BASIS WITHOUT GUARANTEE OR WARRANTY OF ANY KIND.**

1. For updates or additional information about Netsol products, contact your nearest Netsol office.
2. Netsol products are not intended for use in life support, critical care, medical, safety equipment, or similar applications where Product failure could result in loss of life or personal or physical harm, or any military or defense application, or any governmental procurement to which special terms or provisions may apply.

\* Netsol reserves the rights to change products or specification without notice.

**Document Title**

**1Mx36 & 2Mx18 - Bit DDRII+ CIO Burst Length of 2 SRAM w/ ODT  
(2.5 Clock Read Latency)**

**Revision History**

Rev. No.	History	Draft Date	Remark
0.0	Initial Draft	Sep. 2012	Preliminary
1.0	Final spec release Add DC current spec value	Feb. 2013	Final
1.1	Add 400MHz speed binning	Mar. 2013	Final
1.2	Change Thermal Resistance $\theta_{JA}$ value from 20.8°C/W to 16.3°C/W	Apr. 2013	Final
1.3	Updated Application Information Updated Timing Wave Forms (Corrected typos)	Mar. 2014	Final

**1Mx36 & 2Mx18 - Bit DDRII+ CIO Burst Length of 2 SRAM w/ ODT  
(2.5 Clock Read Latency)**

**Features**

- 1.8V+0.1V/-0.1V Power Supply.
- DLL circuitry for wide output data valid window and future frequency scaling.
- I/O Supply Voltage 1.5V+0.1V/-0.1V for 1.5V I/O, 1.8V+0.1V/-0.1V for 1.8V I/O.
- Pipelined, double-data rate operation.
- Common data input/output bus.
- HSTL I/O
- Full data coherency, providing most current data.
- Synchronous pipeline read with self timed late write.
- Read latency: 2.5 clock cycles
- Registered address, control and data input/output.
- DDR (Double Data Rate) Interface on read and write ports.
- Fixed 2-bit burst for both read and write operation.
- Clock-stop supports to reduce current.
- Two input clocks (K and  $\bar{K}$ ) for accurate DDR timing at clock rising edges only.
- Two echo clocks (CQ and  $\bar{CQ}$ ) to enhance output data traceability.
- Data Valid pin (QVLD) supported
- On die termination (ODT) supported for data input, K,  $\bar{K}$  and  $\bar{BW}_x$ .
- Single address bus.
- Byte write (x18, x36) function.
- Simple depth expansion with no data contention.
- Programmable output impedance.
- JTAG 1149.1 compatible test access port.
- 165FBGA(11x15 ball array FBGA) with body size of 13x15mm & Lead Free

**Key Parameters**

Part Number	Org.	Freq. (MHz)	Cycle Time (ns)	Access Time (ns)	RoHS
S7L3236U2M-E(F)C(I)55	x36	550	1.81	0.45	O
S7L3236U2M-E(F)C(I)50		500	2.0	0.45	O
S7L3236U2M-E(F)C(I)45		450	2.2	0.45	O
S7L3236U2M-E(F)C(I)40		400	2.5	0.45	O
S7L3218U2M-E(F)C(I)55	x18	550	1.81	0.45	O
S7L3218U2M-E(F)C(I)50		500	2.0	0.45	O
S7L3218U2M-E(F)C(I)45		450	2.2	0.45	O
S7L3218U2M-E(F)C(I)40		400	2.5	0.45	O

\* -E(F)C(I)  
E(F) [Package type]: E-Pb Free, F-Pb  
C(I) [Operating Temperature]: C-Commercial, I-Industrial

**GENERAL DESCRIPTION**

The S7L3236U2M and S7L3218U2M are 37,748,736-bits DDR Common I/O Synchronous Pipelined Burst SRAMs. They are organized as 1,048,576 words by 36bits for S7L3236U2M and 2,097,152 words by 18 bits for S7L3218U2M. Address, data inputs, and all control signals are synchronized to the input clock (K or  $\bar{K}$ ). Read data are referenced to echo clock (CQ or  $\bar{CQ}$ ) outputs. Read address and write address are registered on rising edges of the input K clocks.

The S7L3236U2M and S7L3218U2M support On Die Termination (ODT) for data input, input clock (K,  $\bar{K}$ ) and  $\bar{BW}_x$ . On Die Termination can reduce the number of resistor elements and complex wiring on the system board. Accordingly, the system design can be simpler and cost effective.

Common address bus is used to access address both for read and write operations. The internal burst counter is fixed to 2-bit sequential for both read and write operations. Synchronous pipeline read and late write enable high speed operations. Simple depth expansion is accomplished by using  $\bar{LD}$  for port selection. Byte write operation is supported with  $\bar{BW}_0$  and  $\bar{BW}_1$  ( $\bar{BW}_2$  and  $\bar{BW}_3$ ) pins for x18 (x36) device

IEEE 1149.1 serial boundary scan (JTAG) simplifies monitoring package pads attachment status with system. The S7L3236U2M and S7L3218U2M are implemented with Netsol's high performance 6T CMOS technology and is available in 165pin FBGA packages. Multiple power and ground pins minimize ground bounce.

**S7L3236U2M**  
**S7L3218U2M**

**1Mx36 & 2Mx18 DDRII+ CIO BL2 SRAM w/ ODT**

**Logic Block Diagram - S7L3236U2M (1M x 36)**

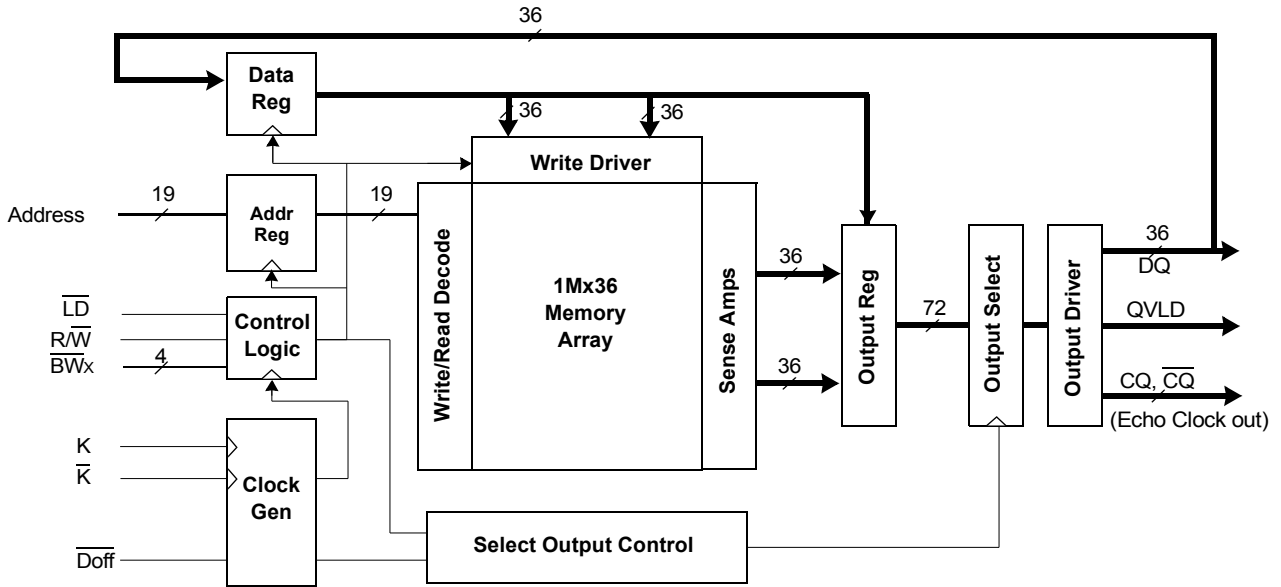

**Logic Block Diagram - S7L3218U2M (2M x 18)**

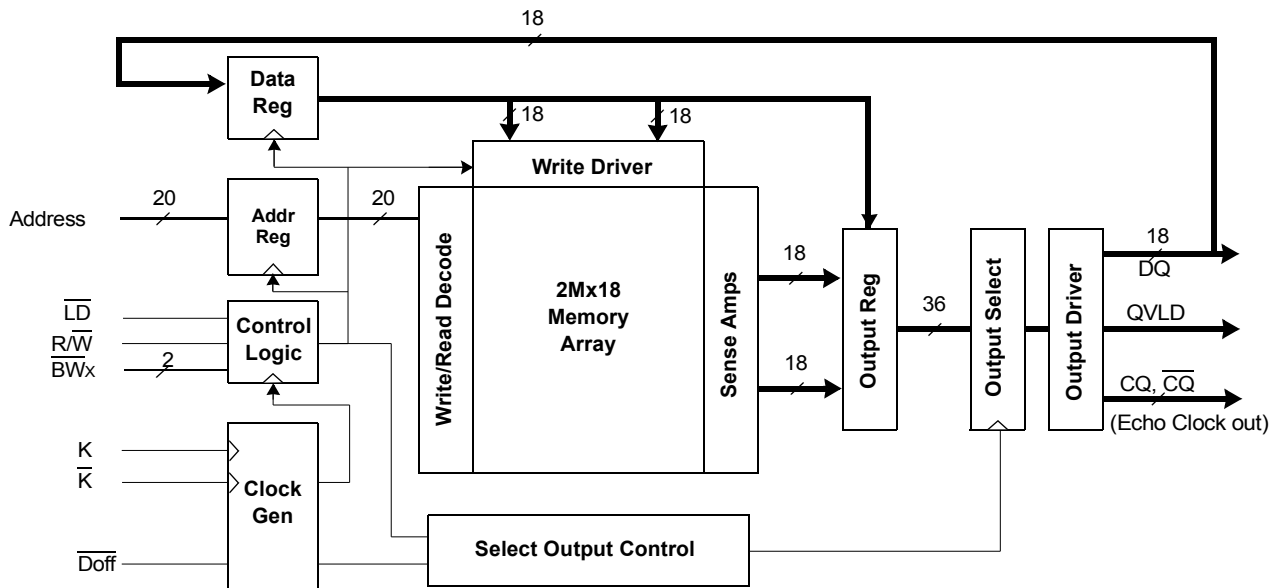

**S7L3236U2M**  
**S7L3218U2M**

**1Mx36 & 2Mx18 DDRII+ CIO BL2 SRAM w/ ODT**

**165FBGA PKG Pin Configurations - S7L3236U2M (1Mx36) - Top View**

	1	2	3	4	5	6	7	8	9	10	11
A	$\overline{CQ}$	NC/SA*	SA	R/W	$\overline{BW}_2$	$\overline{K}$	$\overline{BW}_1$	$\overline{LD}$	SA	NC/SA*	CQ
B	NC	DQ27	DQ18	SA	$\overline{BW}_3$	K	$\overline{BW}_0$	SA	NC	NC	DQ8
C	NC	NC	DQ28	Vss	SA	NC	SA	Vss	NC	DQ17	DQ7
D	NC	DQ29	DQ19	Vss	Vss	Vss	Vss	Vss	NC	NC	DQ16
E	NC	NC	DQ20	VDDQ	Vss	Vss	Vss	VDDQ	NC	DQ15	DQ6
F	NC	DQ30	DQ21	VDDQ	VDD	Vss	VDD	VDDQ	NC	NC	DQ5
G	NC	DQ31	DQ22	VDDQ	VDD	Vss	VDD	VDDQ	NC	NC	DQ14
H	$\overline{Doff}$	VREF	VDDQ	VDDQ	VDD	Vss	VDD	VDDQ	VDDQ	VREF	ZQ
J	NC	NC	DQ32	VDDQ	VDD	Vss	VDD	VDDQ	NC	DQ13	DQ4
K	NC	NC	DQ23	VDDQ	VDD	Vss	VDD	VDDQ	NC	DQ12	DQ3
L	NC	DQ33	DQ24	VDDQ	Vss	Vss	Vss	VDDQ	NC	NC	DQ2
M	NC	NC	DQ34	Vss	Vss	Vss	Vss	Vss	NC	DQ11	DQ1
N	NC	DQ35	DQ25	Vss	SA	SA	SA	Vss	NC	NC	DQ10
P	NC	NC	DQ26	SA	SA	QVLD	SA	SA	NC	DQ9	DQ0
R	TDO	TCK	SA	SA	SA	ODT	SA	SA	SA	TMS	TDI

Notes: 1. \* Checked No Connect (NC) pins are reserved for higher density address, i.e. 10A for 72Mb.  
2.  $\overline{BW}_0$  controls write to DQ0:DQ8,  $\overline{BW}_1$  controls write to DQ9:DQ17,  $\overline{BW}_2$  controls write to DQ18:DQ26 and  $\overline{BW}_3$  controls write to DQ27:DQ35.

**Pin Name**

Symbol	Pin Numbers	Description	Note
K, $\overline{K}$	6B, 6A	Input Clock	1
QVLD	6P	Q Valid output	
ODT	6R	On die termination input	
CQ, $\overline{CQ}$	11A, 1A	Output Echo Clock	
$\overline{Doff}$	1H	DLL Disable when low	
SA	3A,9A,4B,8B,5C,7C,5N-7N,4P,5P,7P,8P,3R-5R,7R-9R	Address Inputs	
DQ0-35	2B,3B,11B,3C,10C,11C,2D,3D,11D,3E,10E,11E,2F,3F 11F,2G,3G,11G,3J,10J,11J,3K,10K,11K,2L,3L,11L 3M,10M,11M,2N,3N,11N,3P,10P,11P	Data Inputs Outputs	
R/W	4A	Read, Write Control Pin, Read active when high	
$\overline{LD}$	8A	Synchronous Load Pin, bus Cycle sequence is to be defined when low	
$\overline{BW}_0, \overline{BW}_1, \overline{BW}_2, \overline{BW}_3$	7B,7A,5A,5B	Block Write Control Pin, active when low	
VREF	2H,10H	Input Reference Voltage	
ZQ	11H	Output Driver Impedance Control Input	2
VDD	5F,7F,5G,7G,5H,7H,5J,7J,5K,7K	Power Supply (1.8 V)	
VDDQ	4E,8E,4F,8F,4G,8G,3H,4H,8H,9H,4J,8J,4K,8K,4L,8L	Output Power Supply (1.5V or 1.8V)	
Vss	4C,8C,4D-8D,5E-7E,6F,6G,6H,6J,6K,5L-7L, 4M-8M,4N,8N	Ground	
TMS	10R	JTAG Test Mode Select	
TDI	11R	JTAG Test Data Input	
TCK	2R	JTAG Test Clock	
TDO	1R	JTAG Test Data Output	
NC	2A,10A,1B,9B,10B,1C,2C,6C,9C,1D,9D,10D,1E,2E,9E, 1F,9F,10F,1G,9G,10G,1J,2J,9J,1K,2K,9K 1L,9L,10L,1M,2M,9M,1N,9N,10N,1P,2P,9P	No Connect	3

Notes: 1. K or  $\overline{K}$  cannot be set to VREF voltage.  
2. When ZQ pin is directly connected to VDD output impedance is set to minimum value and it cannot be connected to ground or left unconnected.  
3. Not connected to chip pad internally.

# S7L3236U2M S7L3218U2M

## 1Mx36 & 2Mx18 DDRII+ CIO BL2 SRAM w/ ODT

### 165FBGA PKG Pin Configurations - S7L3218U2M (2Mx18) - Top View

	1	2	3	4	5	6	7	8	9	10	11
A	$\overline{CQ}$	NC/SA*	SA	R/ $\overline{W}$	$\overline{BW}_1$	$\overline{K}$	NC	$\overline{LD}$	SA	SA	CQ
B	NC	DQ9	NC	SA	NC	K	$\overline{BW}_0$	SA	NC	NC	DQ8
C	NC	NC	NC	V <sub>SS</sub>	SA	NC	SA	V <sub>SS</sub>	NC	DQ7	NC
D	NC	NC	DQ10	V <sub>SS</sub>	V <sub>SS</sub>	V <sub>SS</sub>	V <sub>SS</sub>	V <sub>SS</sub>	NC	NC	NC
E	NC	NC	DQ11	V <sub>DDQ</sub>	V <sub>SS</sub>	V <sub>SS</sub>	V <sub>SS</sub>	V <sub>DDQ</sub>	NC	NC	DQ6
F	NC	DQ12	NC	V <sub>DDQ</sub>	V <sub>DD</sub>	V <sub>SS</sub>	V <sub>DD</sub>	V <sub>DDQ</sub>	NC	NC	DQ5
G	NC	NC	DQ13	V <sub>DDQ</sub>	V <sub>DD</sub>	V <sub>SS</sub>	V <sub>DD</sub>	V <sub>DDQ</sub>	NC	NC	NC
H	$\overline{Doff}$	V <sub>REF</sub>	V <sub>DDQ</sub>	V <sub>DDQ</sub>	V <sub>DD</sub>	V <sub>SS</sub>	V <sub>DD</sub>	V <sub>DDQ</sub>	V <sub>DDQ</sub>	V <sub>REF</sub>	ZQ
J	NC	NC	NC	V <sub>DDQ</sub>	V <sub>DD</sub>	V <sub>SS</sub>	V <sub>DD</sub>	V <sub>DDQ</sub>	NC	DQ4	NC
K	NC	NC	DQ14	V <sub>DDQ</sub>	V <sub>DD</sub>	V <sub>SS</sub>	V <sub>DD</sub>	V <sub>DDQ</sub>	NC	NC	DQ3
L	NC	DQ15	NC	V <sub>DDQ</sub>	V <sub>SS</sub>	V <sub>SS</sub>	V <sub>SS</sub>	V <sub>DDQ</sub>	NC	NC	DQ2
M	NC	NC	NC	V <sub>SS</sub>	V <sub>SS</sub>	V <sub>SS</sub>	V <sub>SS</sub>	V <sub>SS</sub>	NC	DQ1	NC
N	NC	NC	DQ16	V <sub>SS</sub>	SA	SA	SA	V <sub>SS</sub>	NC	NC	NC
P	NC	NC	DQ17	SA	SA	QVLD	SA	SA	NC	NC	DQ0
R	TDO	TCK	SA	SA	SA	ODT	SA	SA	SA	TMS	TDI

Notes: 1. \* Checked No Connect (NC) pins are reserved for higher density address, i.e. 2A for 72Mb.  
2.  $\overline{BW}_0$  controls write to DQ0:DQ8 and  $\overline{BW}_1$  controls write to DQ9:DQ17.

### Pin Name

Symbol	Pin Numbers	Description	Note
K, $\overline{K}$	6B, 6A	Input Clock	1
QVLD	6P	Q Valid output	
ODT	6R	On die termination input	
CQ, $\overline{CQ}$	11A, 1A	Output Echo Clock	
$\overline{Doff}$	1H	DLL Disable when low	
SA	3A,9A,10A,4B,8B,5C,7C,5N-7N,4P,5P,7P,8P,3R-5R,7R-9R	Address Inputs	
DQ0-17	2B,11B,10C,3D,3E,11E,2F,11F,3G,10J,3K,11K,2L,11L 10M,3N,3P,11P	Data Inputs Outputs	
R/ $\overline{W}$	4A	Read, Write Control Pin, Read active when high	
$\overline{LD}$	8A	Synchronous Load Pin, bus Cycle sequence is to be defined when low	
$\overline{BW}_0$ , $\overline{BW}_1$	7B, 5A	Block Write Control Pin, active when low	
V <sub>REF</sub>	2H,10H	Input Reference Voltage	
ZQ	11H	Output Driver Impedance Control Input	2
V <sub>DD</sub>	5F,7F,5G,7G,5H,7H,5J,7J,5K,7K	Power Supply (1.8 V)	
V <sub>DDQ</sub>	4E,8E,4F,8F,4G,8G,3H,4H,8H,9H,4J,8J,4K,8K,4L,8L	Output Power Supply (1.5V or 1.8V)	
V <sub>SS</sub>	4C,8C,4D-8D,5E-7E,6F,6G,6H,6J,6K,5L-7L,4M-8M,4N,8N	Ground	
TMS	10R	JTAG Test Mode Select	
TDI	11R	JTAG Test Data Input	
TCK	2R	JTAG Test Clock	
TDO	1R	JTAG Test Data Output	
NC	2A,7A,1B,3B,5B,9B,10B,1C,2C,3C,6C,9C,11C,1D,2D,9D,10D,11D 1E,2E,9E,10E,1F,3F,9F,10F,1G,2G,9G,10G,11G 1J,2J,3J,9J,11J,1K,2K,9K,10K,1L,3L,9L,10L 1M,2M,3M,9M,11M,1N,2N,9N,10N,11N,1P,2P,9P,10P	No Connect	3

Notes: 1. K or  $\overline{K}$  cannot be set to V<sub>REF</sub> voltage.  
2. When ZQ pin is directly connected to V<sub>DD</sub> output impedance is set to minimum value and it cannot be connected to ground or left unconnected.  
3. Not connected to chip pad internally.

## Read Operations

Read cycles are initiated by initiating  $\overline{R/W}$  as high at the rising edge of the positive input clock K. Address is presented and stored in the read address register synchronized with K clock. For 2-bit burst DDR operation, it will access two 36-bit or 18-bit data words with each read command.

The first pipelined data is transferred out of the device triggered by  $\overline{K}$  clock rising edge. Next burst data is triggered by the rising edge of following K clock rising edge. Continuous read operations are initiated with K clock rising edge. And pipelined data are transferred out of device on every rising edge of both K and  $\overline{K}$  clocks. Initial read data latency is 2.5 clock cycles when DLL is on.

When the  $\overline{LD}$  is disabled after a read operation, the S7L3236U2M and S7L3218U2M will first complete burst read operation before entering into deselect mode at the next K clock rising edge. Then output drivers disabled automatically to high impedance state.

## Write Operations

Write cycles are initiated by activating  $\overline{R/W}$  as low at the rising edge of the positive input clock K. Address is presented and stored in the write address register synchronized with next K clock. For 2-bit burst DDR operation, it will write two 36-bit or 18-bit data words with each write command.

The first "late write" data is transferred and registered into the device synchronous with next K clock rising edge. Next burst data is transferred and registered synchronous with following  $\overline{K}$  clock rising edge. Continuous write operations are initiated with K rising edge. And "late write" data is presented to the device on every rising edge of both K and  $\overline{K}$  clocks.

When the  $\overline{LD}$  is disabled, the S7L3236U2M and S7L3218U2M will enter into deselect mode. The device disregards input data presented on the same cycle  $\overline{LD}$  disabled.

The S7L3236U2M and S7L3218U2M support byte write operations. With activating  $\overline{BW}_0$  or  $\overline{BW}_1$  ( $\overline{BW}_2$  or  $\overline{BW}_3$ ) in write cycle, only one byte of input data is presented. In S7L3218U2M,  $\overline{BW}_0$  controls write operation to D0:D8,  $\overline{BW}_1$  controls write operation to D9:D17. And in S7L3236U2M,  $\overline{BW}_2$  controls write operation to D18:D26,  $\overline{BW}_3$  controls write operation to D27:D35.

## Depth Expansion

Each port can be selected and deselected independently with  $\overline{R/W}$  be shared among all SRAMs and provide a new  $\overline{LD}$  signal for each bank. Before chip deselected, all read and write pending operations are completed.

## Programmable Impedance Output Buffer Operation

The designer can program the SRAM's output buffer impedance by terminating the ZQ pin to Vss through a precision resistor (RQ). The value of RQ (within 15%) is five times the output impedance desired. For example, 250Ω resistor will give an output impedance of 50Ω. Impedance updates occur early in cycles that do not activate the outputs, such as deselect cycles. In all cases impedance updates are transparent to the user and do not produce access time "push-outs" or other anomalous behavior in the SRAM. There are no power up requirements for the SRAM. However, to guarantee optimum output driver impedance after power up, the SRAM needs 1024 non-read cycles.

## Output Valid Pin (QVLD)

The QVLD indicates valid output data. QVLD is activated half cycle before the read data for the receiver to be ready for capturing the data. QVLD is edge aligned with CQ and  $\overline{CQ}$ .

### **Echo clock operation**

To assure the output traceability, the SRAM provides the output Echo clock, pair of compliment clock CQ and  $\overline{CQ}$ , which are synchronized with internal data output. Echo clocks run free during normal operation. The Echo clock is triggered by internal output clock signal, and transferred to external through same structures as output driver.

### **Clock Consideration**

S7L3236U2M and S7L3218U2M utilize internal DLL (Delay-Locked Loops) for maximum output data valid window. It can be placed into a stopped-clock state to minimize power with a modest restart time of 2048 clock cycles. Circuitry automatically resets the DLL when absence of input clock is detected.

### **On Die Termination Impedance**

S7L3236U2M and S7L3218U2M support On Die Termination (ODT). The input signal level on ODT pin determines the impedance range of on die termination. If ODT pin is tied High, termination impedance will be in high range which is equal to  $RQ \times 0.6$  for  $175\Omega \leq RQ \leq 350\Omega$ . If ODT pin is tied low, termination impedance will be in low range which is equal to  $RQ \times 0.3$  for  $175\Omega \leq RQ \leq 250\Omega$ . Default impedance range when ODT pin is not connected is high.

### **Power-Up/Power-Down Supply Voltage Sequencing**

The following power-up supply voltage application is recommended: VSS, VDD, VDDQ, VREF, then VIN. VDD and VDDQ can be applied simultaneously, as long as VDDQ does not exceed VDD by more than 0.5V during power-up. The following power-down supply voltage removal sequence is recommended: VIN, VREF, VDDQ, VDD, VSS. VDD and VDDQ can be removed simultaneously, as long as VDDQ does not exceed VDD by more than 0.5V during power-down.

### **Detail Specification of Power-Up Sequence in DDRII+ SRAM**

DDRII+ SRAMs must be powered up and initialized in a predefined manner to prevent undefined operations.

#### **• Power-Up Sequence**

1. Apply power and keep  $\overline{Doff}$  at low state (All other inputs may be undefined)
  - Apply VDD before VDDQ
  - Apply VDDQ before VREF or the same time with VREF
2. Just after the stable power and clock (K,  $\overline{K}$ ), take  $\overline{Doff}$  to be high.
3. The additional 2048 cycles of clock input is required to lock the DLL after enabling DLL

\* **Notes:** If you want to tie up the  $\overline{Doff}$  pin to High with unstable clock, then you must stop the clock for a few seconds (Min. 30ns) to reset the DLL after it become a stable clock status.

#### **• DLL Constraints**

1. DLL uses K clock as its synchronizing input, the input should have low phase jitter which is specified as TK var.
2. The lower end of the frequency at which the DLL can operate is 120MHz.
3. If the incoming clock is unstable and the DLL is enabled, then the DLL may lock onto a wrong frequency and this may cause the failure in the initial stage.



**Power up & Initialization Sequence ( $\overline{\text{Doff}}$  pin controlled)**

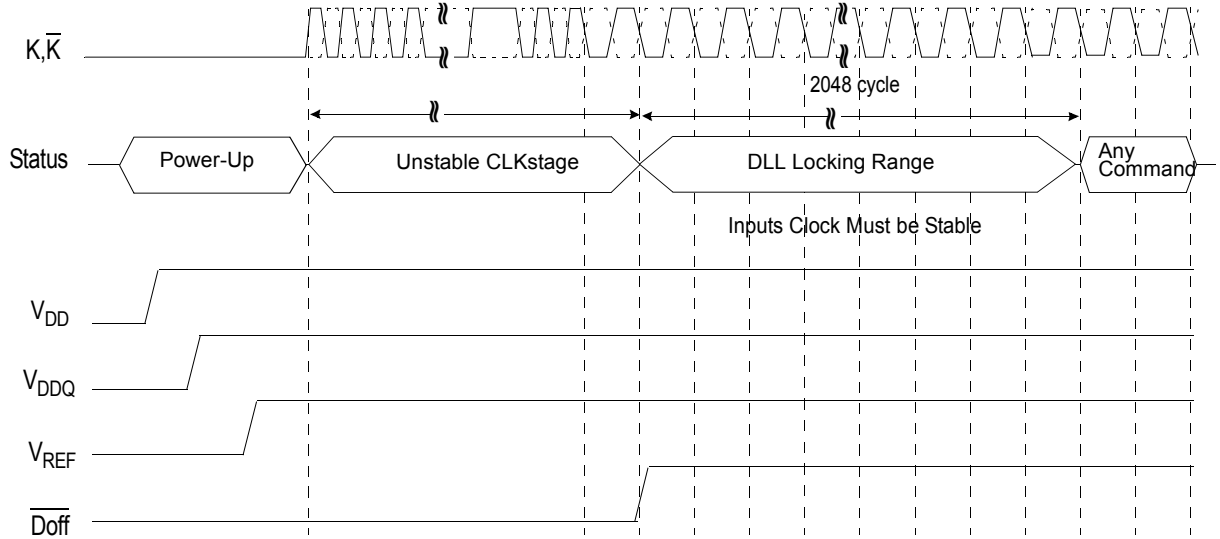

**Power up & Initialization Sequence ( $\overline{\text{Doff}}$  pin Fixed high, Clock controlled)**

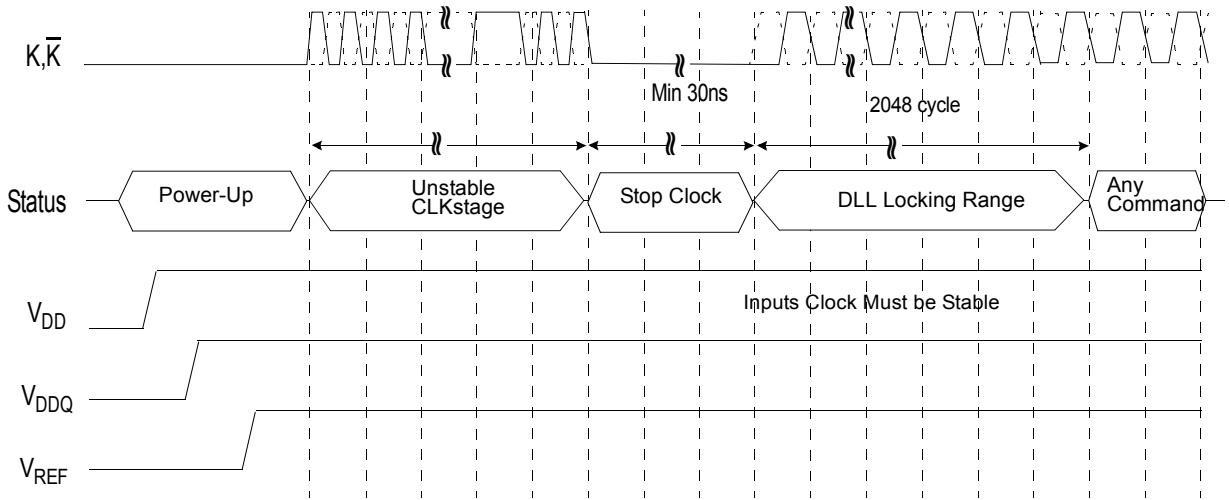

\* **Notes:** When the operating frequency is changed, It is required to reset DLL again.  
After resetting DLL, the minimum 2048 cycles of clock input is needed to lock the DLL.

Truth Tables

SYNCHRONOUS TRUTH TABLE

K	$\overline{\text{LD}}$	R/ $\overline{\text{W}}$	DQ		OPERATION
			DQ(A0)	DQ(A1)	
Stopped	X	X	Previous state	Previous state	Clock Stop
↑	H	X	High-Z	High-Z	No Operation
↑	L	H	QOUT at $\overline{\text{K}}(t+2)$	QOUT at $\text{K}(t+3)$	Read
↑	L	L	Din at $\text{K}(t+1)$	Din at $\overline{\text{K}}(t+1)$	Write

- Notes: 1. X means "Don't Care".  
 2. The rising edge of clock is symbolized by (↑).  
 3. Before enter into clock stop status, all pending read and write operations will be completed.

WRITE TRUTH TABLE<sub>(x18)</sub>

K	$\overline{\text{K}}$	$\overline{\text{BW}}_0$	$\overline{\text{BW}}_1$	OPERATION
↑		L	L	WRITE ALL BYTES (K↑)
	↑	L	L	WRITE ALL BYTES ( $\overline{\text{K}}$ ↑)
↑		L	H	WRITE BYTE 0 (K↑)
	↑	L	H	WRITE BYTE 0 ( $\overline{\text{K}}$ ↑)
↑		H	L	WRITE BYTE 1 (K↑)
	↑	H	L	WRITE BYTE 1 ( $\overline{\text{K}}$ ↑)
↑		H	H	WRITE NOTHING (K↑)
	↑	H	H	WRITE NOTHING ( $\overline{\text{K}}$ ↑)

- Notes: 1. X means "Don't Care".  
 2. All inputs in this table must meet setup and hold time around the rising edge of input clock K or  $\overline{\text{K}}$  (↑).  
 3. Assumes a WRITE cycle was initiated.  
 4. This table illustrates operation for x18 devices.

WRITE TRUTH TABLE<sub>(x36)</sub>

K	$\overline{\text{K}}$	$\overline{\text{BW}}_0$	$\overline{\text{BW}}_1$	$\overline{\text{BW}}_2$	$\overline{\text{BW}}_3$	OPERATION
↑		L	L	L	L	WRITE ALL BYTES (K↑)
	↑	L	L	L	L	WRITE ALL BYTES ( $\overline{\text{K}}$ ↑)
↑		L	H	H	H	WRITE BYTE 0 (K↑)
	↑	L	H	H	H	WRITE BYTE 0 ( $\overline{\text{K}}$ ↑)
↑		H	L	H	H	WRITE BYTE 1 (K↑)
	↑	H	L	H	H	WRITE BYTE 1 ( $\overline{\text{K}}$ ↑)
↑		H	H	L	L	WRITE BYTE 2 and BYTE 3 (K↑)
	↑	H	H	L	L	WRITE BYTE 2 and BYTE 3 ( $\overline{\text{K}}$ ↑)
↑		H	H	H	H	WRITE NOTHING (K↑)
	↑	H	H	H	H	WRITE NOTHING ( $\overline{\text{K}}$ ↑)

- Notes: 1. X means "Don't Care".  
 2. All inputs in this table must meet setup and hold time around the rising edge of input clock K or  $\overline{\text{K}}$  (↑).  
 3. Assumes a WRITE cycle was initiated.

**Absolute Maximum Ratings\***

Parameter		Symbol	Rating	Unit
Voltage on V <sub>DD</sub> Supply Relative to V <sub>SS</sub>		V <sub>DD</sub>	-0.5 to 2.9	V
Voltage on V <sub>DDQ</sub> Supply Relative to V <sub>SS</sub>		V <sub>DDQ</sub>	-0.5 to V <sub>DD</sub>	V
Voltage on Input Pin Relative to V <sub>SS</sub>		V <sub>IN</sub>	-0.5 to V <sub>DD</sub> +0.3	V
Storage Temperature		T <sub>STG</sub>	-65 to 150	°C
Operating Temperature	Commercial / Industrial	T <sub>OPR</sub>	0 to 70 / -40 to 85	°C
Storage Temperature Range Under Bias		T <sub>BIAS</sub>	-10 to 85	°C

- \*Note:** 1. Stresses greater than those listed under "Absolute Maximum Ratings" may cause permanent damage to the device. This is a stress rating only and functional operation of the device at these or any other conditions above those indicated in the operating sections of this specification is not implied. Exposure to absolute maximum rating conditions for extended periods may affect reliability.  
 2. V<sub>DDQ</sub> must not exceed V<sub>DD</sub> during normal operation.

**OPERATING CONDITIONS (0°C ≤ T<sub>A</sub> ≤ 70°C)**

Parameter	Symbol	Min	Typ	Max	Unit
Supply Voltage	V <sub>DD</sub>	1.7	1.8	1.9	V
	V <sub>DDQ</sub>	1.4	1.5	1.9	V
Reference Voltage	V <sub>REF</sub>	0.7	0.75	0.95	V
Input Low Voltage (DC) <sup>2,3</sup>	V <sub>IL(DC)</sub>	-0.3	-	V <sub>REF</sub> - 0.1	V
Input High Voltage (DC) <sup>2,4</sup>	V <sub>IH(DC)</sub>	V <sub>REF</sub> + 0.1	-	V <sub>DDQ</sub> + 0.3	V
Input Low Voltage (AC) <sup>6,7</sup>	V <sub>IL(AC)</sub>	-	-	V <sub>REF</sub> - 0.2	V
Input High Voltage (AC) <sup>6,7</sup>	V <sub>IH(AC)</sub>	V <sub>REF</sub> + 0.2	-	-	V

- Note:** 1. V<sub>DDQ</sub> must not exceed V<sub>DD</sub> during normal operation.  
 2. These are DC test criteria. DC design criteria is V<sub>REF</sub>±50mV. The AC V<sub>IH</sub>/V<sub>IL</sub> levels are defined separately for measuring timing parameters.  
 3. V<sub>IL</sub> (Min) DC=-0.3V, V<sub>IL</sub> (Min) AC=-1.5V(pulse width ≤ 3ns).  
 4. V<sub>IH</sub> (Max) DC=V<sub>DDQ</sub>+0.3V, V<sub>IH</sub> (Max) AC=V<sub>DDQ</sub>+0.85V(pulse width ≤ 3ns).  
 5. Overshoot: V<sub>IH</sub> (AC) ≤ V<sub>DDQ</sub>+0.5V for t ≤ 50% t<sub>KHKH</sub> (MIN).  
 Undershoot: V<sub>IL</sub> (AC) ≤ V<sub>SS</sub>-0.5V for t ≤ 50% t<sub>KHKH</sub> (MIN).  
 6. This condition is for AC function test only, not for AC parameter test.  
 7. To maintain a valid level, the transiting edge of the input must:  
 a) Sustain a constant slew rate from the current AC level through the target AC level, V<sub>IL(AC)</sub> or V<sub>IH(AC)</sub>  
 b) Reach at least the target AC level  
 c) After the AC target level is reached, continue to maintain at least the target DC level, V<sub>IL(DC)</sub> or V<sub>IH(DC)</sub>

**DC Electrical Characteristics**

Parameter	Symbol	test Conditions	Min	Max	Unit	Notes
Input Leakage Current	IIL	VDD=Max; VIN=VSS to VDDQ	-2	+2	μA	
Output Leakage Current	IOL	Output Disabled,	-2	+2	μA	
Operating Current (x36)	ICC	VDD=Max, IOUT=0mA Cycle Time ≥ tKHKH Min	-55	655	mA	1,4
			-50	610		
			-45	565		
			-40	520		
Operating Current (x18)	ICC	VDD=Max, IOUT=0mA Cycle Time ≥ tKHKH Min	-55	590	mA	1,4
			-50	550		
			-45	510		
			-40	470		
Standby Current (NOP)	ISB1	Device deselected, IOUT=0mA, f=Max, All Inputs ≤ 0.2V or ≥ VDD-0.2V	-55	315	mA	1,5
			-50	300		
			-45	285		
			-40	270		
Output High Voltage	VOH1		VDDQ/2-0.12	VDDQ/2+0.12	V	2,6
Output Low Voltage	VOL1		VDDQ/2-0.12	VDDQ/2+0.12	V	2,6
Output High Voltage	VOH2	I <sub>OH</sub> =-1.0mA	VDDQ-0.2	VDDQ	V	3
Output Low Voltage	VOL2	I <sub>OL</sub> =1.0mA	VSS	0.2	V	3

- Notes:**
1. Minimum cycle. IOUT=0mA.
  2.  $|I_{OH}| = (V_{DDQ}/2)/(RQ/5) \pm 15\%$  for  $175\Omega \leq RQ \leq 350\Omega$ .  $|I_{OL}| = (V_{DDQ}/2)/(RQ/5) \pm 15\%$  for  $175\Omega \leq RQ \leq 350\Omega$ .
  3. Minimum Impedance Mode when ZQ pin is connected to VDD.
  4. Operating current is calculated with 100% read cycles or 100% write cycles.
  5. Standby Current is only after all pending read and write burst operations are completed.
  6. Programmable Impedance Mode.

**AC Electrical Characteristics**

Parameter	Symbol	Min	Max	Unit	Notes
Input High Voltage	V <sub>IH</sub> (AC)	V <sub>REF</sub> + 0.2	-	V	1,2
Input Low Voltage	V <sub>IL</sub> (AC)	-	V <sub>REF</sub> - 0.2	V	1,2

- Notes:** 1. This condition is for AC function test only, not for AC parameter test.  
2. To maintain a valid level, the transition edge of the input must:  
a) Sustain a constant slew rate from the current AC level through the target AC level, V<sub>IL(AC)</sub> or V<sub>IH(AC)</sub>  
b) Reach at least the target AC level  
c) After the AC target level is reached, continue to maintain at least the target DC level, V<sub>IL(DC)</sub> or V<sub>IH(DC)</sub>

**AC Timing Characteristics**

Parameter	Symbol	-55		-50		-45		-40		Unit	Notes
		Min	Max	Min	Max	Min	Max	Min	Max		
<b>Clock</b>											
Clock Cycle Time (K, $\bar{K}$ )	t <sub>KHKH</sub>	1.81	8.40	2.0	8.40	2.22	8.40	2.5	8.40	ns	
Clock Phase Jitter (K, $\bar{K}$ )	t <sub>K var</sub>		0.15		0.15		0.15		0.15	ns	4
Clock High Time (K, $\bar{K}$ )	t <sub>KHKL</sub>	0.4		0.4		0.4		0.4		ns	
Clock Low Time (K, $\bar{K}$ )	t <sub>KLKH</sub>	0.4		0.4		0.4		0.4		ns	
Clock to $\bar{C}lock$ (K $\uparrow$ → $\bar{K}\uparrow$ )	t <sub>KH<math>\bar{K}</math>H</sub>	0.77		0.85		0.94		1.06		ns	
DLL Lock Time (K)	t <sub>K lock</sub>	2048		2048		2048		2048		cycle	5
K Static to DLL reset	t <sub>K reset</sub>	30		30		30		30		ns	
<b>Output Times</b>											
K, $\bar{K}$ High to Output Valid	t <sub>KHQV</sub>		0.45		0.45		0.45		0.45	ns	
K, $\bar{K}$ High to Output Hold	t <sub>KHQX</sub>	-0.45		-0.45		-0.45		-0.45		ns	
K, $\bar{K}$ High to Echo Clock Valid	t <sub>KHCQV</sub>		0.45		0.45		0.45		0.45	ns	
K, $\bar{K}$ High to Echo Clock Hold	t <sub>KHCQX</sub>	-0.45		-0.45		-0.45		-0.45		ns	
CQ, $\bar{C}Q$ High to Output Valid	t <sub>CQHQV</sub>		0.15		0.15		0.15		0.2	ns	
CQ, $\bar{C}Q$ High to Output Hold	t <sub>CQHQX</sub>	-0.15		-0.15		-0.15		-0.2		ns	
CQ High to $\bar{C}Q$ High	t <sub>CQH<math>\bar{C}Q</math>H</sub>	0.655		0.75		0.85		1.0			6
K, $\bar{K}$ , High to Output High-Z	t <sub>KHZ</sub>		0.45		0.45		0.45		0.45	ns	
K, $\bar{K}$ , High to Output Low-Z	t <sub>KLZ</sub>	-0.45		-0.45		-0.45		-0.45		ns	
CQ, $\bar{C}Q$ High to QVLD Valid	t <sub>QVLD</sub>	-0.15	0.15	-0.15	0.15	-0.15	0.15	-0.2	0.2	ns	
<b>Setup Times</b>											
Address valid to K rising edge	t <sub>AVKH</sub>	0.23		0.25		0.275		0.40		ns	
Control inputs valid to K rising edge	t <sub>IVKH</sub>	0.23		0.25		0.275		0.40		ns	2
Data-in valid to K, $\bar{K}$ rising edge	t <sub>DVKH</sub>	0.18		0.20		0.22		0.28		ns	
<b>Hold Times</b>											
K rising edge to address hold	t <sub>KHAX</sub>	0.23		0.25		0.275		0.40		ns	
K rising edge to control inputs hold	t <sub>KHIX</sub>	0.23		0.25		0.275		0.40		ns	
K, $\bar{K}$ rising edge to data-in hold	t <sub>KHDX</sub>	0.18		0.20		0.22		0.28		ns	

- Notes:** 1. All address inputs must meet the specified setup and hold times for all latching clock edges.  
2. Control signals are R/ W and LD.  
However BWx does not apply to this parameters.  $\bar{B}Wx$  signals obey the data setup and hold times.  
3. To avoid bus contention, at a given voltage and temperature t<sub>KLZ</sub> is bigger than t<sub>KHZ</sub>.  
The specs as shown do not imply bus contention because t<sub>KLZ</sub> is a MIN parameter that is worst case at totally different test conditions (0°C, 1.9V) than t<sub>KHZ</sub>, which is a MAX parameter (worst case at 70°C, 1.7V)  
It is not possible for two SRAMs on the same board to be at such different voltage and temperature.  
4. Clock phase jitter is the variance from clock rising edge to the next expected clock rising edge.  
5. V<sub>dd</sub> slew rate must be less than 0.1V DC per 50 ns for DLL lock retention. DLL lock time begins once V<sub>dd</sub> and input clock are stable.  
6. This parameter is extrapolated from the input timing parameters (t<sub>KH $\bar{K}$ H</sub> - 200ps where 200ps is the internal jitter.) This parameter is only guaranteed by design and not tested in production.

# S7L3236U2M S7L3218U2M

## 1Mx36 & 2Mx18 DDRII+ CIO BL2 SRAM w/ ODT

### Thermal Resistance

Parameter	Symbol	Typical	Unit	Notes
Junction to Ambient	$\theta_{JA}$	16.3	$^{\circ}\text{C/W}$	
Junction to Case	$\theta_{JC}$	2.3	$^{\circ}\text{C/W}$	
Junction to Pins	$\theta_{JB}$	4.3	$^{\circ}\text{C/W}$	

**Note:** Junction temperature is a function of on-chip power dissipation, package thermal impedance, mounting site temperature and mounting site thermal impedance.  $T_J = T_A + P_D \times \theta_{JA}$

### Pin Capacitance

Parameter	Symbol	Test Condition	Typ	Max	Unit	Notes
Address Control Input Capacitance	$C_{IN}$	$V_{IN}=0\text{V}$	3.5	4	pF	
Input and Output Capacitance	$C_{OUT}$	$V_{OUT}=0\text{V}$	4	5	pF	
Clock Capacitance	$C_{CLK}$	-	3	4	pF	

**Note:** 1. Parameters are tested with  $R_Q=250\Omega$  and  $V_{DDQ}=1.5\text{V}$ .  
2. Periodically sampled and not 100% tested.

### AC Test Conditions

Parameter	Symbol	Value	Unit
Core Power Supply Voltage	$V_{DD}$	1.7~1.9	V
Output Power Supply Voltage	$V_{DDQ}$	1.4~1.9	V
Input High/Low Level	$V_{IH}/V_{IL}$	1.25/0.25	V
Input Reference Level	$V_{REF}$	0.75	V
Input Rise/Fall Time	$T_R/T_F$	0.3/0.3	ns
Output Timing Reference Level		$V_{DDQ}/2$	V

**Note:** Parameters are tested with  $R_Q=250\Omega$

### AC Test Output Load

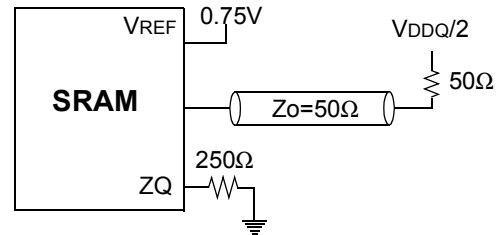

Application Information

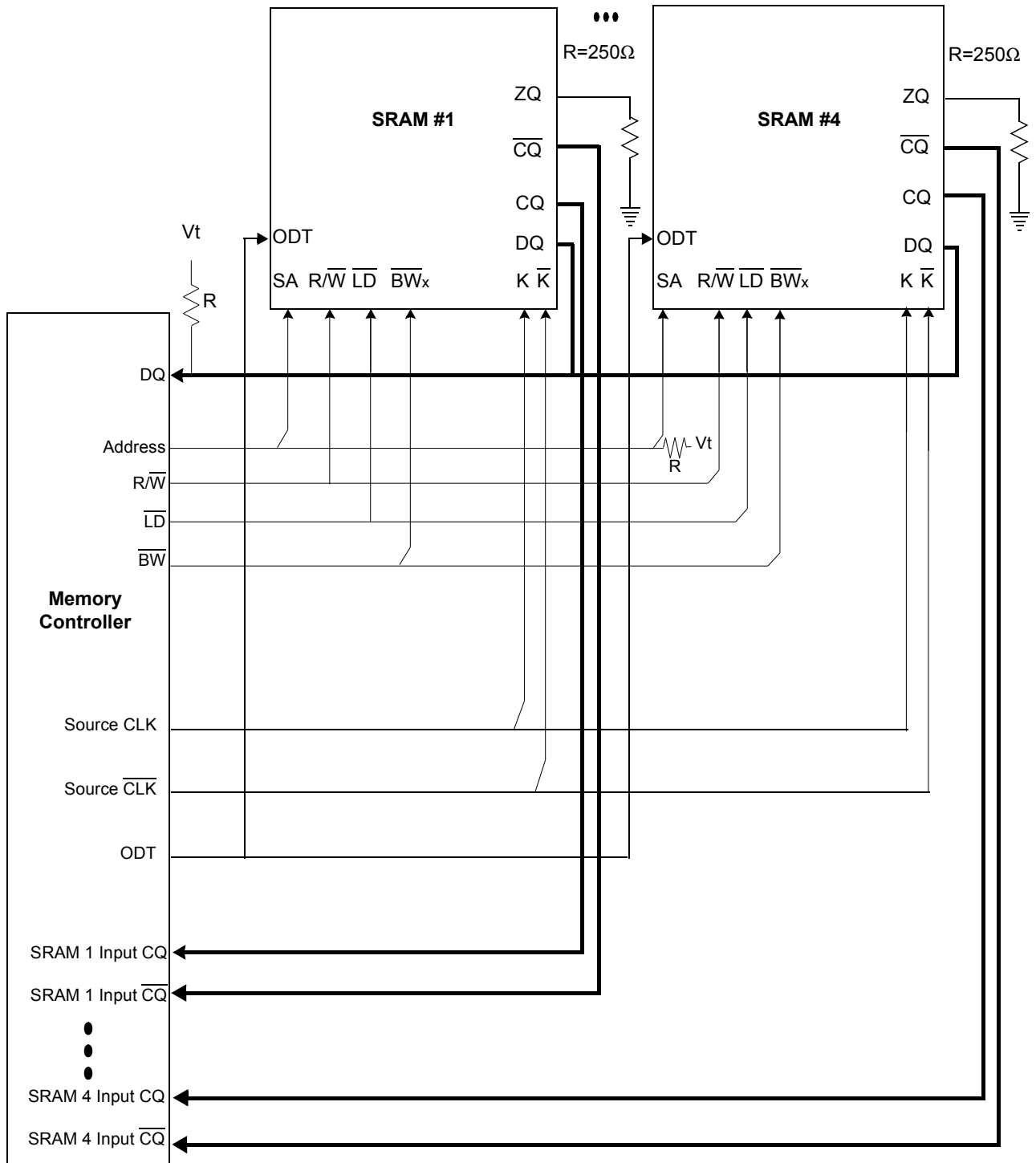

TIMING WAVE FORMS OF READ, WRITE AND NOP

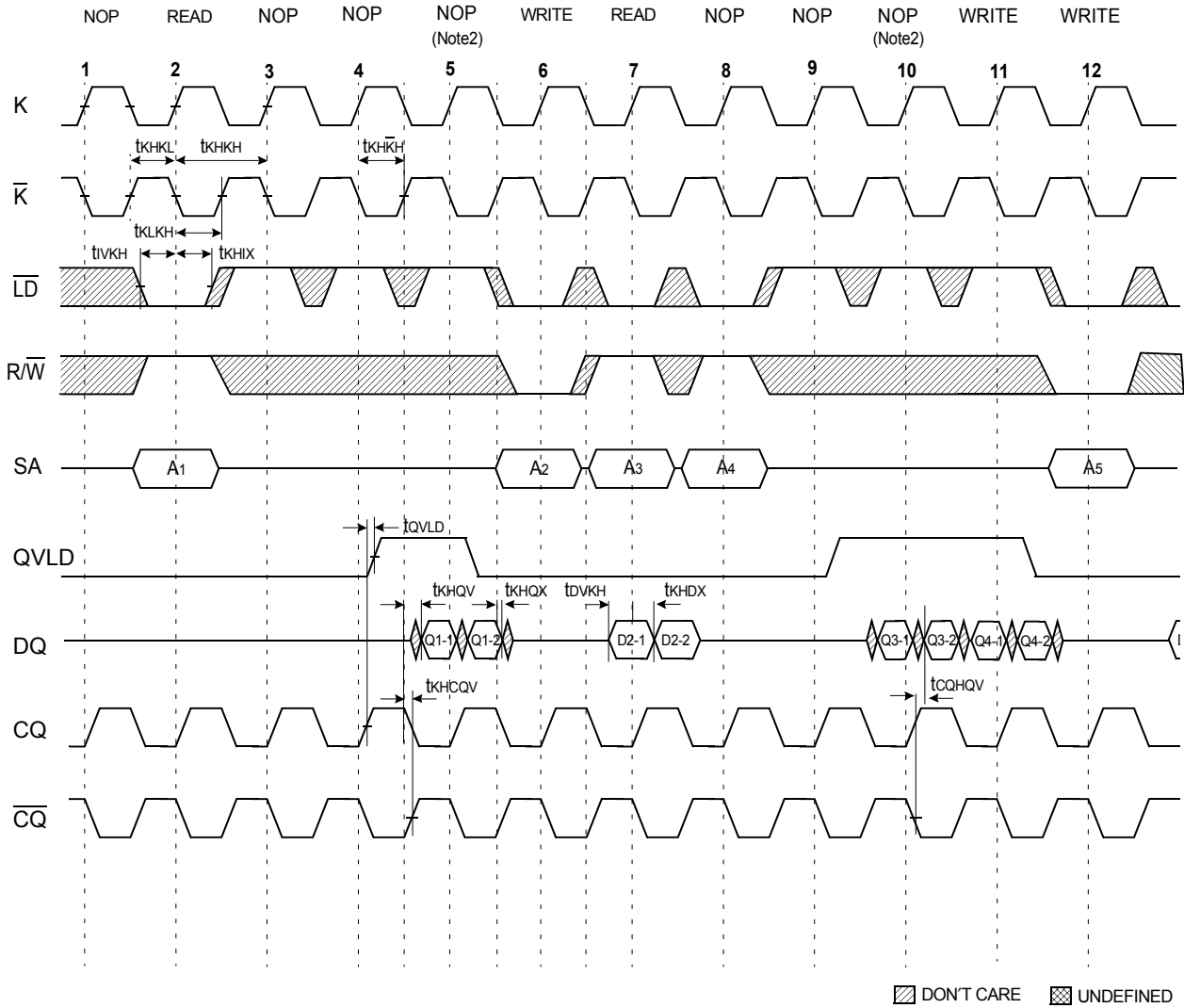

NOTE

1. Q1-1 refers to output from address A1. Q1-2 refers to output from the next internal burst address following A1, etc.
2. Two NOP cycle is the mandatory and 3<sup>rd</sup> NOP cycle is not necessary for correct DDRII+ READ/WRITE operation. However at high clock frequencies, considering the delay of real system board condition, it may be required to prevent bus contention.



**IEEE 1149.1 Test Access Port and Boundary Scan-JTAG**

This part contains an IEEE standard 1149.1 Compatible Test Access Port (TAP). The package pads are monitored by the Serial Scan circuitry when in test mode. This is to support connectivity testing during manufacturing and system diagnostics. Internal data is not driven out of the SRAM under JTAG control. In conformance with IEEE 1149.1, the SRAM contains a TAP controller, Instruction Register, Bypass Register and ID register. The TAP controller has a standard 16-state machine that resets internally upon power-up, therefore, TRST signal is not required. It is possible to use this device without utilizing the TAP. To disable the TAP controller without interfacing with normal operation of the SRAM, TCK must be tied to Vss to preclude mid level input. TMS and TDI are designed so an undriven input will produce a response identical to the application of a logic 1, and may be left unconnected. But they may also be tied to VDD through a resistor. TDO should be left unconnected.

**JTAG Block Diagram**

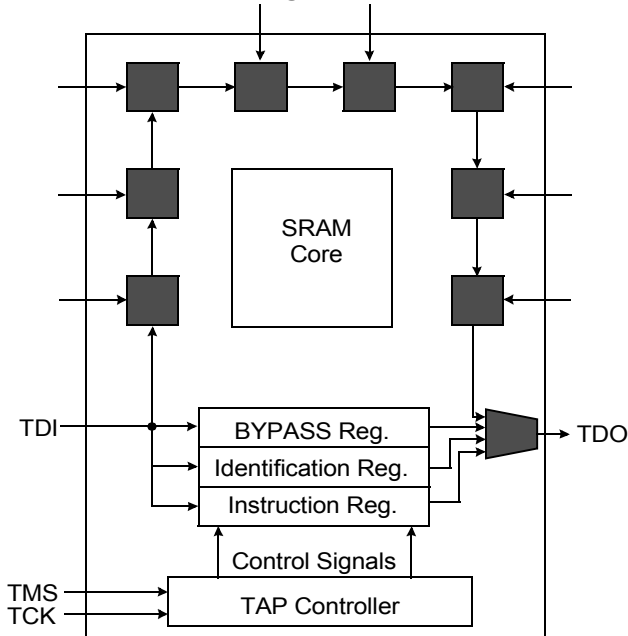

**JTAG Instruction Coding**

IR2	IR1	IR0	Instruction	TDO Output	Notes
0	0	0	EXTEST	Boundary Scan Register	1
0	0	1	IDCODE	Identification Register	3
0	1	0	SAMPLE-Z	Boundary Scan Register	2
0	1	1	RESERVED	Do Not Use	6
1	0	0	SAMPLE	Boundary Scan Register	5
1	0	1	RESERVED	Do Not Use	6
1	1	0	RESERVED	Do Not Use	6
1	1	1	BYPASS	Bypass Register	4

**NOTE:**

1. Places DQs in Hi-Z in order to sample all input data regardless of other SRAM inputs. This instruction is not IEEE 1149.1 compliant.
2. Places DQs in Hi-Z in order to sample all input data regardless of other SRAM inputs.
3. TDI is sampled as an input to the first ID register to allow for the serial shift of the external TDI data.
4. Bypass register is initiated to Vss when BYPASS instruction is invoked. The Bypass Register also holds serially loaded TDI when exiting the Shift DR states.
5. SAMPLE instruction dose not places DQs in Hi-Z.
6. This instruction is reserved for future use.

**TAP Controller State Diagram**

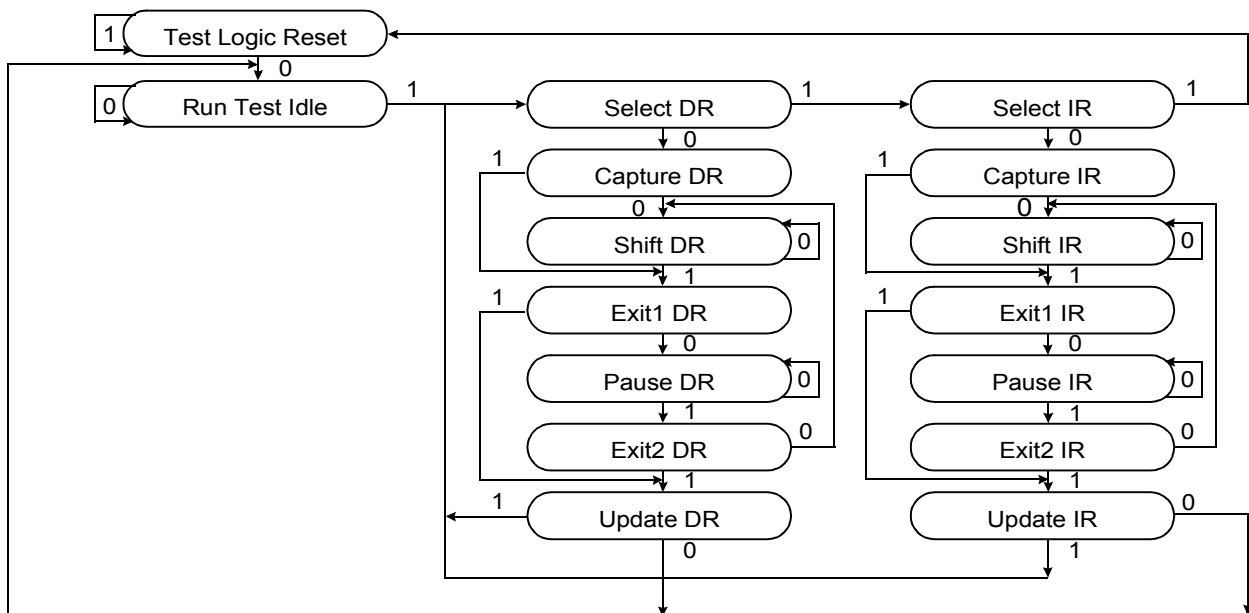

# S7L3236U2M S7L3218U2M

## 1Mx36 & 2Mx18 DDRII+ CIO BL2 SRAM w/ ODT

### Scan Register Definition

Part	Instruction Register	Bypass Register	ID Register	Boundary Scan
1M x 36 2M x 18	3 bits	1 bit	32 bits	109 bits

### ID Registration Definition

Part	Revision Number (31:29)	Part Configuration (28:12)	Netsol JEDEC Code (11: 1)	Start Bit(0)
1M x 36 2M x 18	000	00def0wx0tpqIb0s0	01111011001	1

**Note:** Part Configuration

/def=010 for 36Mb, /wx=11 for x36, 10 for x18

/t=1 for DLL Ver., 0 for non-DLL Ver.

/q=1 for Quadruple, 0 for DDR

/b=1 for 4Bit Burst, 0 for 2Bit Burst

/p=1 for Quadruple-II+ or DDR-II+, 0 for Quadruple-II or DDR-II

/l=1 for 2.5 read latency, 0 for 2.0 read latency (applicable only to Quadruple-II+ and DDR-II+)

/s=1 for Separate I/O, 0 for Common I/O

### Boundary Scan Exit Order

Order	Pin ID
1	6R
2	6P
3	6N
4	7P
5	7N
6	7R
7	8R
8	8P
9	9R
10	11P
11	10P
12	10N
13	9P
14	10M
15	11N
16	9M
17	9N
18	11L
19	11M
20	9L
21	10L
22	11K
23	10K
24	9J
25	9K
26	10J
27	11J
28	11H
29	10G
30	9G
31	11F
32	11G
33	9F
34	10F
35	11E
36	10E

Order	Pin ID
37	10D
38	9E
39	10C
40	11D
41	9C
42	9D
43	11B
44	11C
45	9B
46	10B
47	11A
48	10A
49	9A
50	8B
51	7C
52	6C
53	8A
54	7A
55	7B
56	6B
57	6A
58	5B
59	5A
60	4A
61	5C
62	4B
63	3A
64	2A
65	1A
66	2B
67	3B
68	1C
69	1B
70	3D
71	3C
72	1D

Order	Pin ID
73	2C
74	3E
75	2D
76	2E
77	1E
78	2F
79	3F
80	1G
81	1F
82	3G
83	2G
84	1H
85	1J
86	2J
87	3K
88	3J
89	2K
90	1K
91	2L
92	3L
93	1M
94	1L
95	3N
96	3M
97	1N
98	2M
99	3P
100	2N
101	2P
102	1P
103	3R
104	4R
105	4P
106	5P
107	5N
108	5R
109	Internal

**Note:** 1. NC pins are read as "X" (i.e. don't care.)

**JTAG DC Operating Conditions**

Parameter	Symbol	Min	Typ	Max	Unit	Note
Power Supply Voltage	V <sub>DD</sub>	1.7	1.8	1.9	V	
Input High Level	V <sub>IH</sub>	1.3	-	V <sub>DD</sub> +0.3	V	
Input Low Level	V <sub>IL</sub>	-0.3	-	0.5	V	
Output High Voltage (I <sub>OH</sub> =-2mA)	V <sub>OH</sub>	1.4	-	V <sub>DD</sub>	V	
Output Low Voltage(I <sub>OL</sub> =2mA)	V <sub>OL</sub>	V <sub>SS</sub>	-	0.4	V	

**Note:** 1. The input level of SRAM pin is to follow the SRAM DC specification.

**JTAG AC Test Conditions**

Parameter	Symbol	Min	Unit	Note
Input High/Low Level	V <sub>IH</sub> /V <sub>IL</sub>	1.8/0.0	V	
Input Rise/Fall Time	TR/TF	1.0/1.0	ns	
Input and Output Timing Reference Level		0.9	V	1

**Note:** 1. See SRAM AC test output load on page 11.

**JTAG AC Characteristics**

Parameter	Symbol	Min	Max	Unit	Note
TCK Cycle Time	t <sub>CHCH</sub>	50	-	ns	
TCK High Pulse Width	t <sub>CHCL</sub>	20	-	ns	
TCK Low Pulse Width	t <sub>CLCH</sub>	20	-	ns	
TMS Input Setup Time	t <sub>MVCH</sub>	5	-	ns	
TMS Input Hold Time	t <sub>CHMX</sub>	5	-	ns	
TDI Input Setup Time	t <sub>DVCH</sub>	5	-	ns	
TDI Input Hold Time	t <sub>CHDX</sub>	5	-	ns	
SRAM Input Setup Time	t <sub>SVCH</sub>	5	-	ns	
SRAM Input Hold Time	t <sub>CHSX</sub>	5	-	ns	
Clock Low to Output Valid	t <sub>CLQV</sub>	0	10	ns	

**JTAG Timing Diagram**

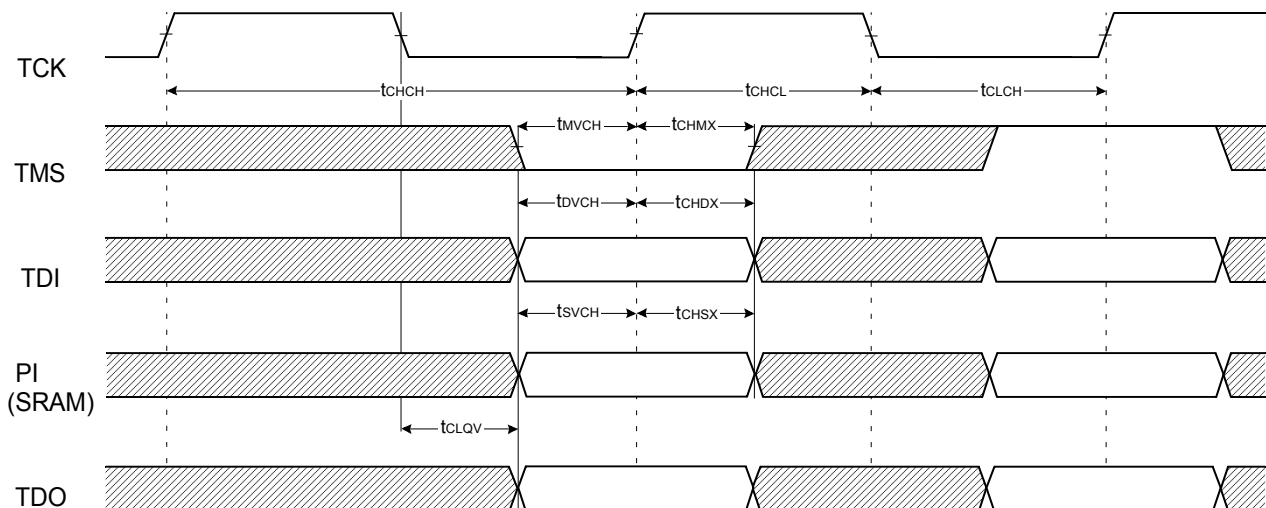

**S7L3236U2M**  
**S7L3218U2M**

**1Mx36 & 2Mx18 DDRII+ CIO BL2 SRAM w/ ODT**

**165 FBGA Package Dimensions - Lead & Lead Free**  
**13mm x 15mm Body, 1.0mm Bump Pitch, 11x15 Ball Grid Array**

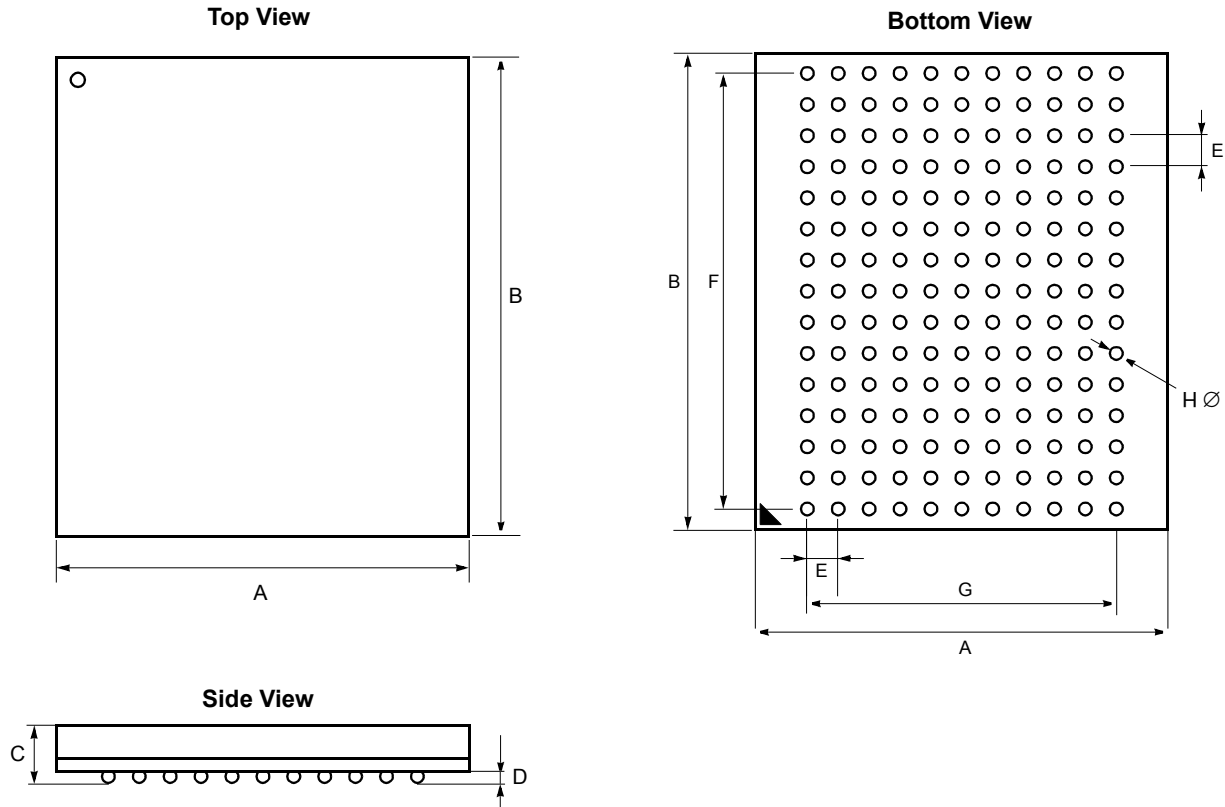

Symbol	Value	Units	Note	Symbol	Value	Units	Note
<b>A</b>	13 ± 0.1	mm		<b>E</b>	1.0	mm	
<b>B</b>	15 ± 0.1	mm		<b>F</b>	14.0	mm	
<b>C</b>	1.3 ± 0.1	mm		<b>G</b>	10.0	mm	
<b>D</b>	0.35 ± 0.05	mm		<b>H</b>	0.5 ± 0.05	mm	