



## Silicon Epitaxial Planar Transistor

## S8550W

### FEATURES

- High Collector Current.( $I_C = -500\text{Ma}$ ).
- Complementary To S8050W.
- Excellent  $H_{FE}$  Linearity.



### APPLICATIONS

- High Collector Current.

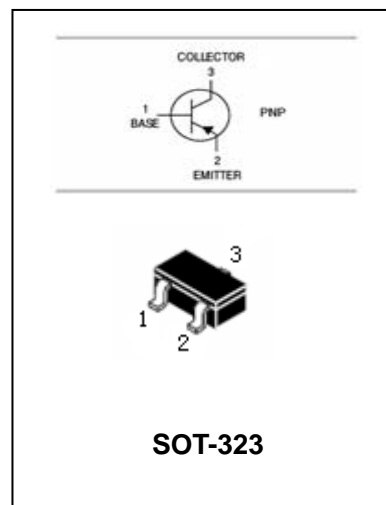

### ORDERING INFORMATION

Type No.	Marking	Package Code
S8550W	2TY	SOT-323

### MAXIMUM RATING @ $T_a = 25^\circ\text{C}$ unless otherwise specified

Symbol	Parameter	Value	Units
$V_{CBO}$	Collector-Base Voltage	-40	V
$V_{CEO}$	Collector-Emitter Voltage	-25	V
$V_{EBO}$	Emitter-Base Voltage	-5	V
$I_C$	Collector Current -Continuous	-500	mA
$P_C$	Collector Dissipation	300	mW
$T_j, T_{stg}$	Junction and Storage Temperature	-55 to +150	$^\circ\text{C}$



**Silicon Epitaxial Planar Transistor**

**S8550W**

**ELECTRICAL CHARACTERISTICS @ Ta=25°C unless otherwise specified**

Parameter	Symbol	Test conditions	MIN	TYP	MAX	UNIT
Collector-base breakdown voltage	$V_{(BR)CBO}$	$I_C = -100\mu A, I_E = 0$	-40			V
Collector-emitter breakdown voltage	$V_{(BR)CEO}$	$I_C = -1mA, I_B = 0$	-25			V
Emitter-base breakdown voltage	$V_{(BR)EBO}$	$I_E = -100\mu A, I_C = 0$	-5			V
Collector cut-off current	$I_{CBO}$	$V_{CB} = -40V, I_E = 0$			-0.1	$\mu A$
Collector cut-off current	$I_{CEO}$	$V_{CE} = -20V, I_B = 0$			-0.1	$\mu A$
Emitter cut-off current	$I_{EBO}$	$V_{EB} = -3V, I_C = 0$			-0.1	$\mu A$
DC current gain	$h_{FE}$	$V_{CE} = -1V, I_C = -50mA$	120	350		
		$V_{CE} = -1V, I_C = -500mA$	50			
Collector-emitter saturation voltage	$V_{CE(sat)}$	$I_C = -500mA, I_B = -50mA$			-0.6	V
Base-emitter saturation voltage	$V_{BE(sat)}$	$I_C = -500mA, I_B = -50mA$			-1.2	V
Transition frequency	$f_T$	$V_{CE} = -6V, I_C = -20mA$ $f = 30MHz$	150			MHz

**CLASSIFICATION OF  $h_{FE(1)}$**

Rank	L	H
Range	120-200	200-350

**Silicon Epitaxial Planar Transistor**

**S8550W**

TYPICAL CHARACTERISTICS @ Ta=25°C unless otherwise specified

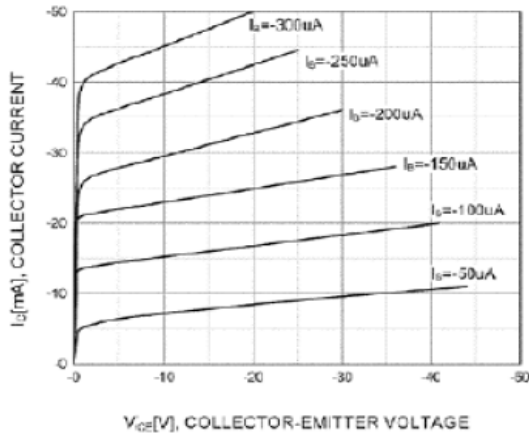

**Static Characteristic**

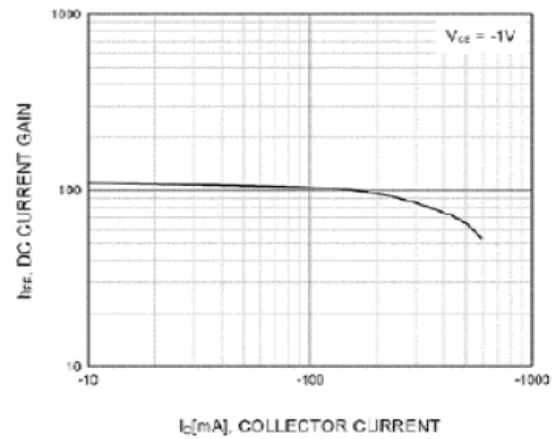

**DC current Gain**

**Silicon Epitaxial Planar Transistor**

**S8550W**

**PACKAGE OUTLINE**

Plastic surface mounted package

SOT-323

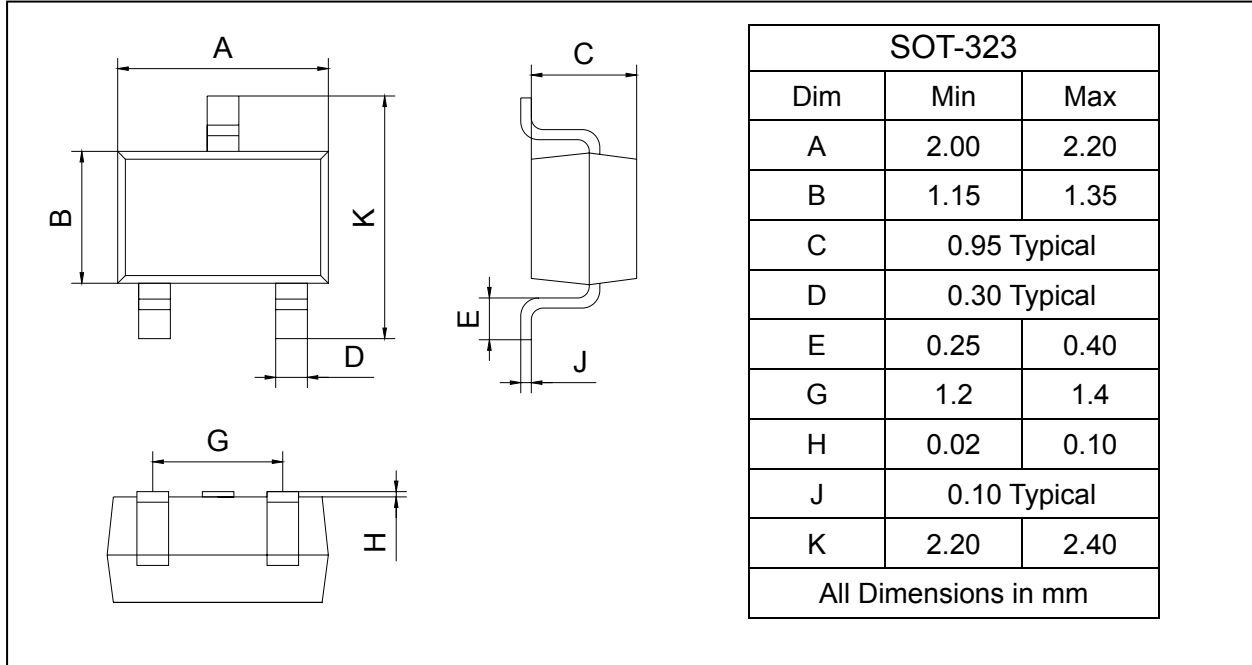

**SOLDERING FOOTPRINT**

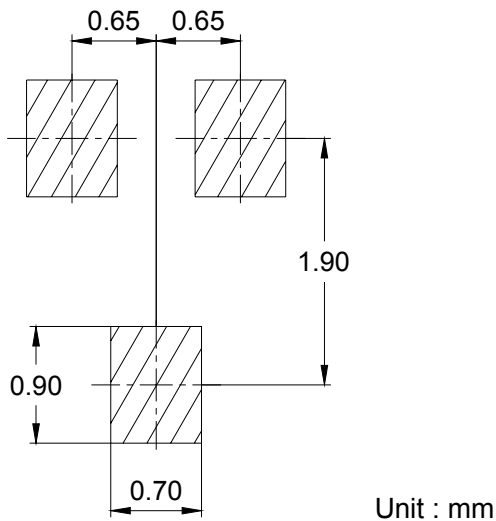

**PACKAGE INFORMATION**

Device	Package	Shipping
S8550W	SOT-323	3000/Tape&Reel