

N-Channel MOSFET

Features

- 85V,120A,Rds(on)(typ)=5.8mΩ @Vgs=10V
- High Ruggedness
- Fast Switching
- 100% Avalanche Tested
- Improved dv/dt Capability

General Description

This Power MOSFET is produced using Si-Tech's advanced Trench MOS Technology. This latest technology has been especially designed to minimize on-state resistance, have a high rugged avalanche characteristics. These devices are well suited for low voltage application such as automotive, DC/DC converters, and high efficiency switch for power management in portable and battery products.

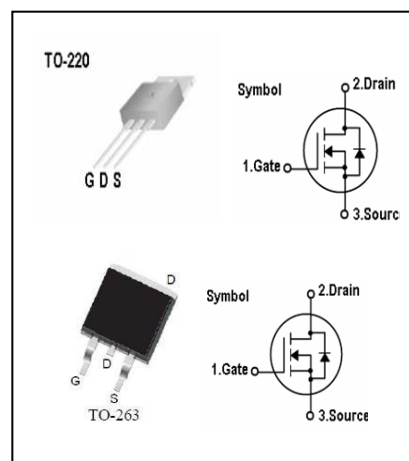

Absolute Maximum Ratings

Symbol	Parameter	Value	Units
V _{DSS}	Drain-Source Voltage	85	V
I _D	Continuous Drain Current (T _c =25°C)	120	A
	Continuous Drain Current (T _c =100°C)	84	A
I _{DM}	Pulsed Drain Current (Note 1)	450	A
V _{GS}	Gate-Source Voltage	± 20	V
E _{AS}	Single Pulsed Avalanche Energy (Note 2)	928	mJ
P _D	Maximum Power Dissipation (T _c =25°C)	230	W
	Derating Factor above 25°C	1.53	W/°C
T _J	Operating Junction Temperature Range	-55 to +175	°C
T _{STG}	Storage Temperature Range	-55 to +175	°C

Thermal Characteristics

Symbol	Parameter	Max.	Units
R _{th j-c}	Thermal Resistance, Junction to case	0.65	°C/W
R _{th c-s}	Thermal Resistance, Case to Sink	0.5	°C/W
R _{th j-a}	Thermal Resistance, Junction to Ambient	62.5	°C/W

Electrical Characteristics ($T_C=25^\circ\text{C}$ unless otherwise noted)

Symbol	Parameter	Test Conditions	Min.	Typ.	Max.	Units
BV _{DSS}	Drain-Source Breakdown Voltage	V _{GS} =0V, I _D =250uA	85	-	-	V
I _{DSS}	Drain-Source Leakage Current	V _{DS} =80V, V _{GS} =0V	-	-	1	uA
I _{GSS}	Gate Leakage Current, Forward	V _{GS} =20V, V _{DS} =0V	-	-	100	nA
	Gate Leakage Current, Reverse	V _{GS} =-20V, V _{DS} =0V	-	-	-100	nA
V _{GS(th)}	Gate Threshold Voltage	V _{GS} =V _{DS} , I _D =250uA	2	-	4	V
R _{DS(on)}	Drain-Source On-State Resistance	V _{GS} =10V, I _D =40A	-	5.8	7	mΩ
Q _g	Total Gate Charge	V _{DD} =60V	-	120	-	nC
Q _{gs}	Gate-Source Charge	V _{GS} =10V	-	32	-	nC
Q _{gd}	Gate-Drain Charge	I _D =80A (Note 3)	-	50	-	nC
t _{d(on)}	Turn-on Delay Time	V _{DD} =37.5V, V _{GS} =10V	-	25	-	ns
t _r	Turn-on Rise Time	I _D =45A, R _G =4.7Ω	-	66	-	ns
t _{d(off)}	Turn-off Delay Time	T _C =25°C	-	36	-	ns
t _f	Turn-off Fall Time	(Note 3)	-	24	-	ns
C _{iss}	Input Capacitance -	V _{DS} =25V	-	3700	-	pF
C _{oss}	Output Capacitance	V _{GS} =0V	-	430	-	pF
C _{rss}	Reverse Transfer Capacitance	f = 1MHz	-	230	-	pF

Source-Drain Diode Characteristics ($T_C=25^\circ\text{C}$ unless otherwise noted)

Symbol	Parameter	Test Conditions	Min.	Typ.	Max.	Units
I _s	Continuous Source Diode Forward Current		-	-	120	A
I _{SM}	Pulsed Source Diode Forward Current (Note 1)		-	-	450	A
V _{SD}	Forward On Voltage	V _{GS} =0V, I _s =45A	-	-	1.2	V
t _{rr}	Reverse Recovery Time	V _{GS} =0V, I _s =45A	-	100	150	ns
Q _{rr}	Reverse Recovery Charge	dI _F /dt = 100A/us	-	410	650	nC

Notes:

1. Repetitive Rating: Pulse width limited by maximum junction temperature
2. L=0.5mH, V_{DD}=50V, R_G=25 Ω, Starting T_J=25°C
3. Pulse Width ≤ 300 us; Duty Cycle ≤ 2%

Typical Characteristics

Output Characteristics

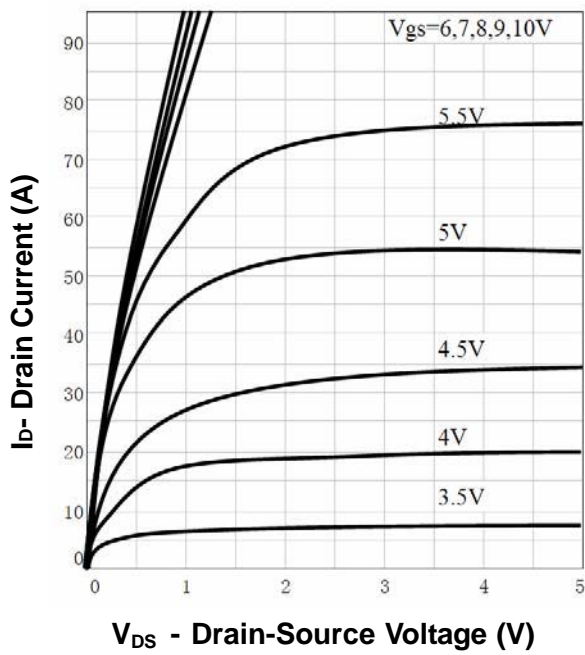

Drain Current

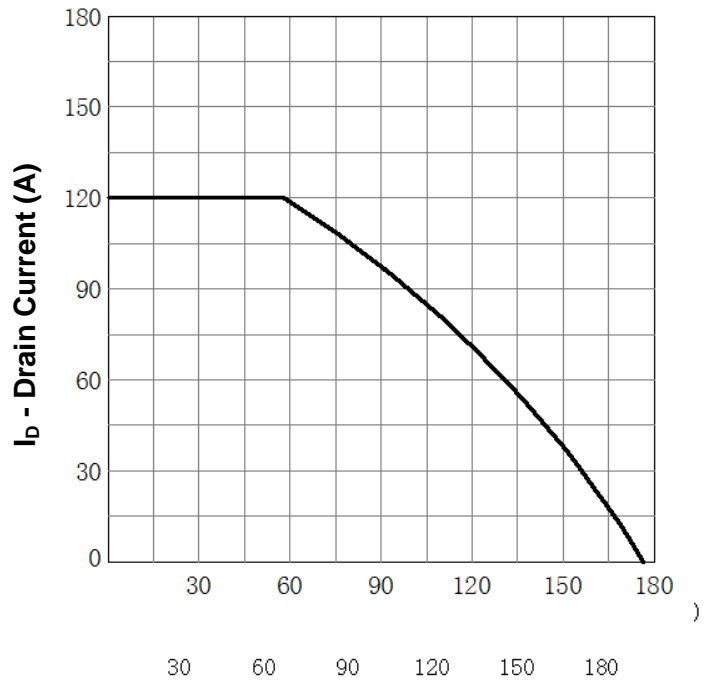

Safe Operation Area

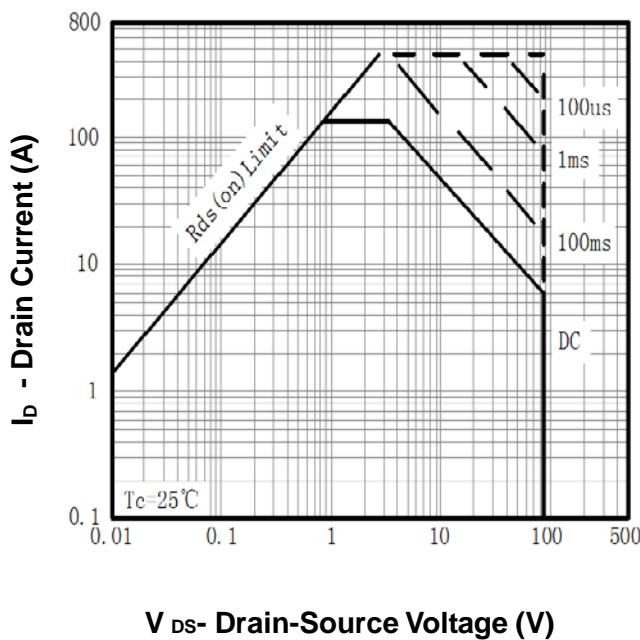

Thermal Transient Impedance

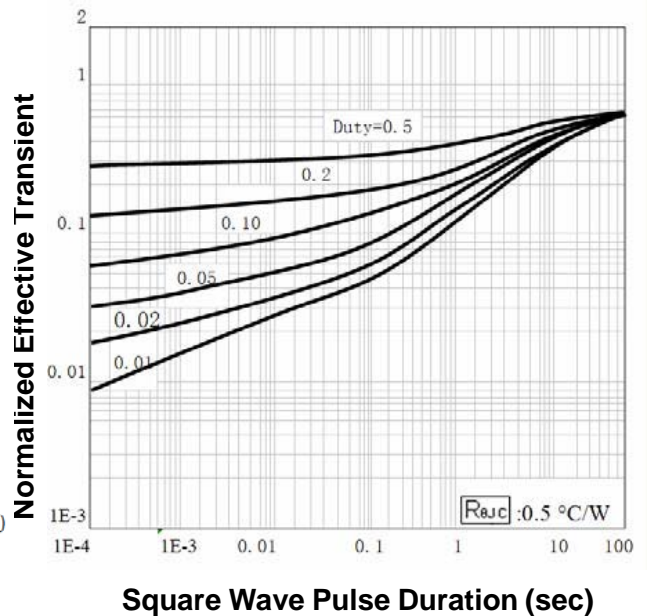

Typical Characteristics

Power Dissipation

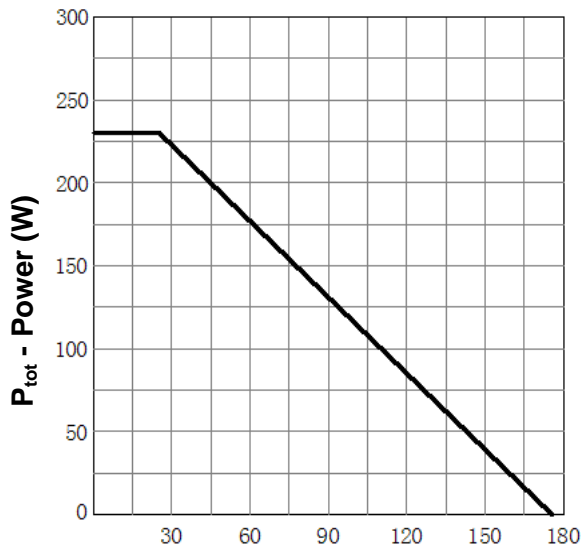

T_j - Junction Temperature (°C)

Drain-Source On Resistance

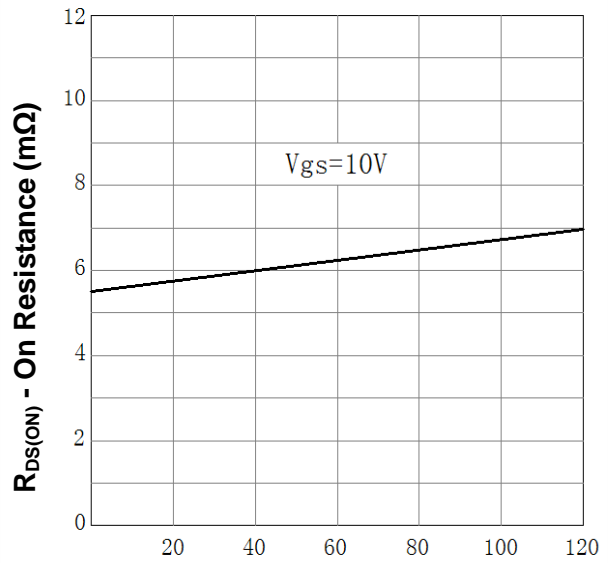

I_D - Drain Current (A)

Drain-Source On Resistance

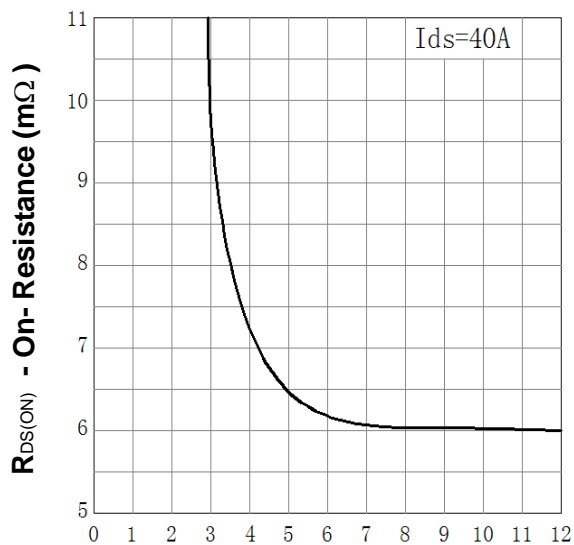

V_{GS} - Gate-Source Voltage (V)

Gate Threshold Voltage

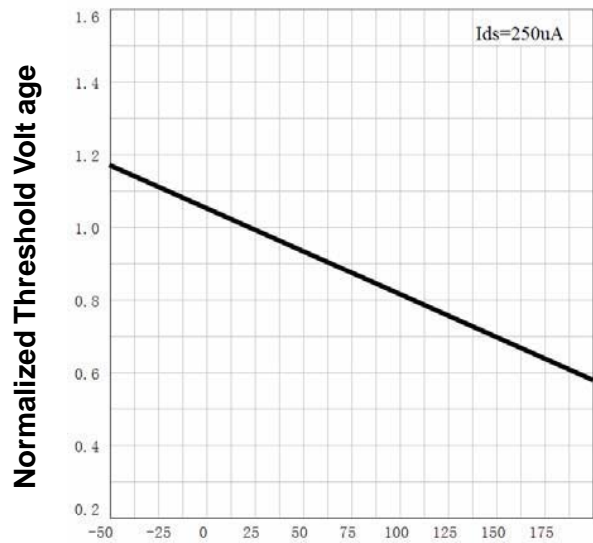

T_j - Junction Temperature (°C)

Typical Characteristics

Drain-Source On Resistance

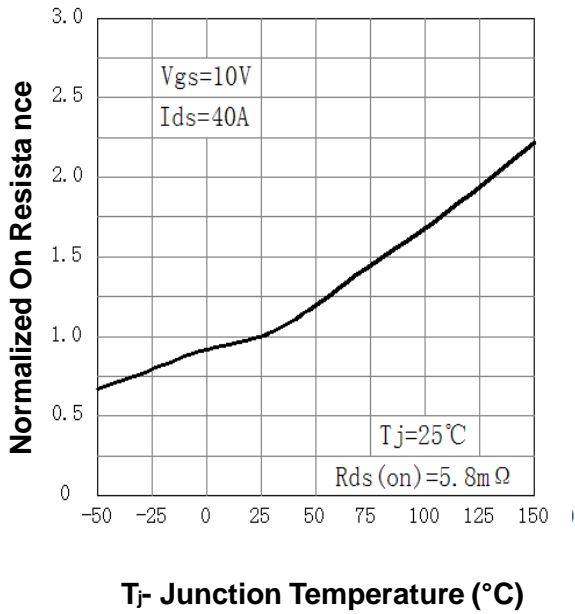

Source-Drain Diode Forward

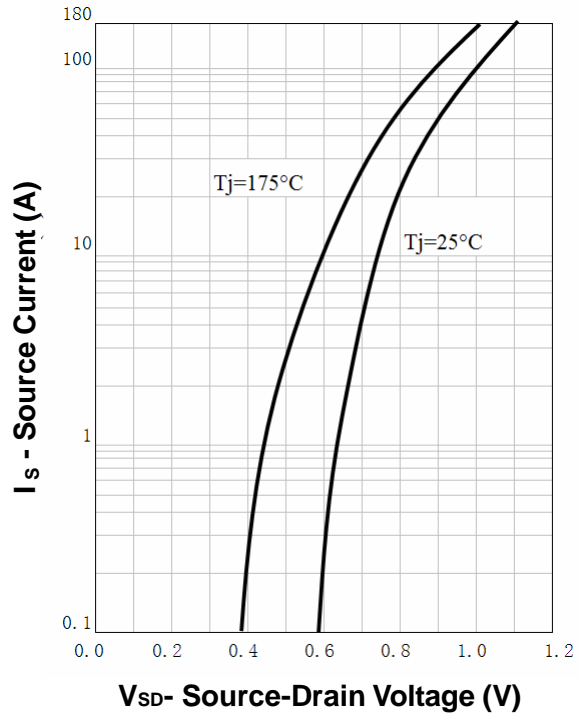

Capacitance

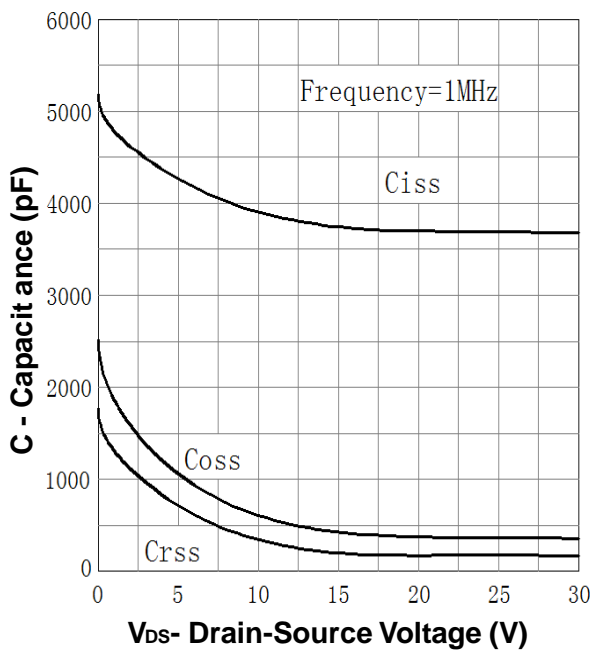

Gate Charge

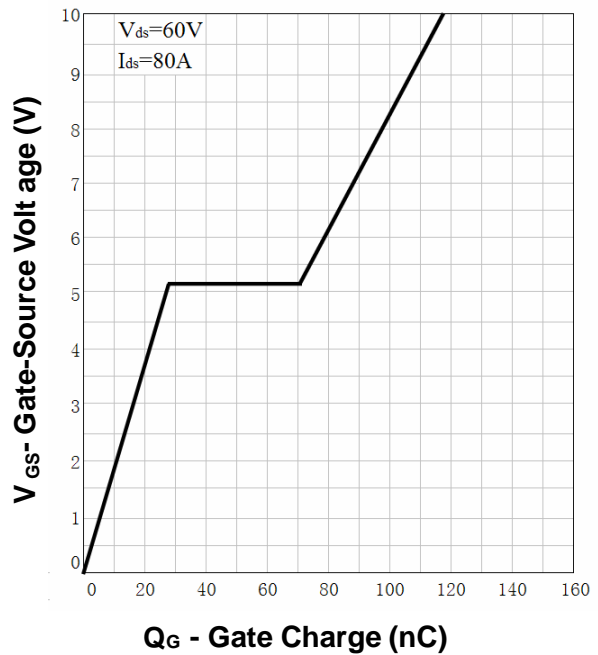

Avalanche Test Circuit and Waveforms

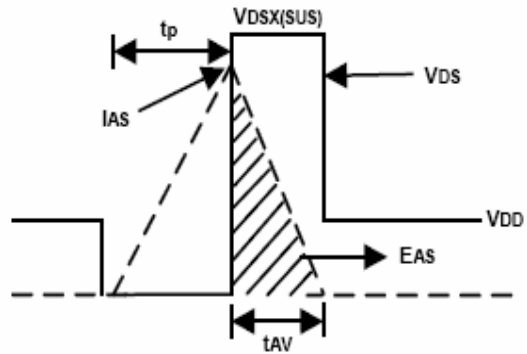
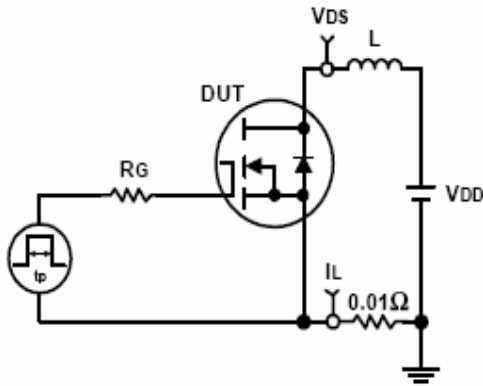

Switching Time Test Circuit and Waveforms

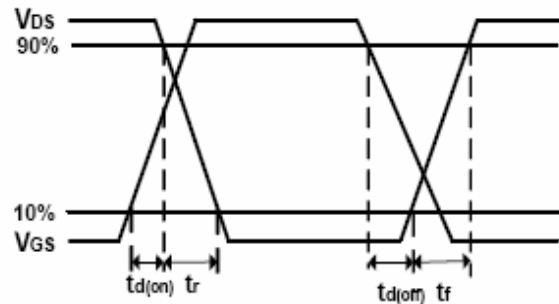
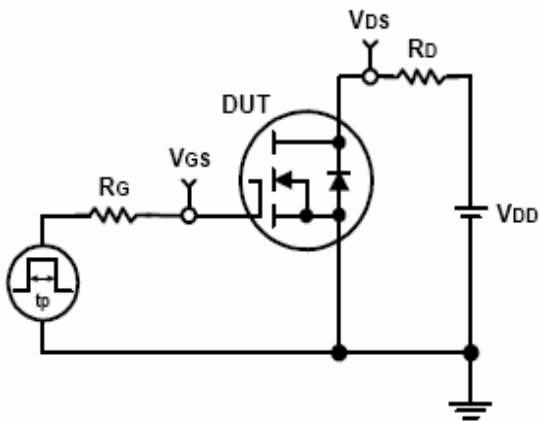

Package Outline

Dimensions are shown in millimeters

R: TO220

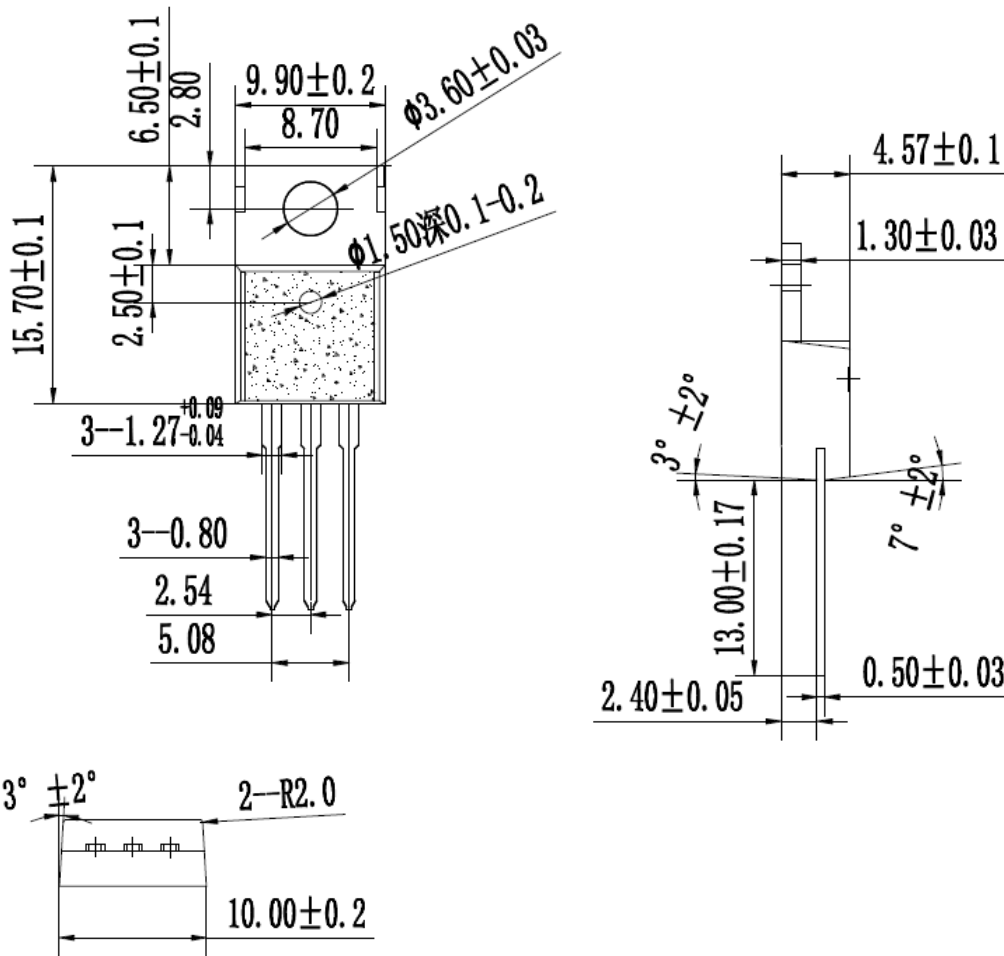

S: TO263 (D²PAK)

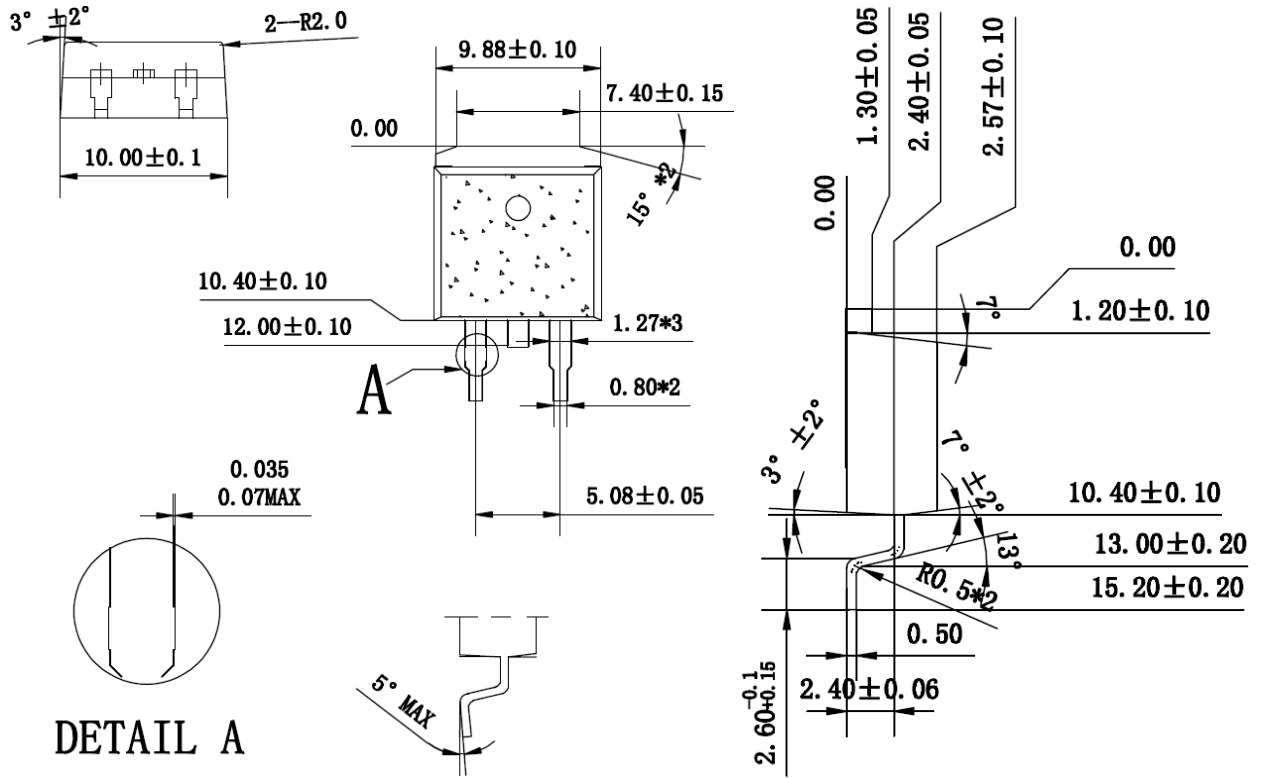

RP: TO220 (短脚)

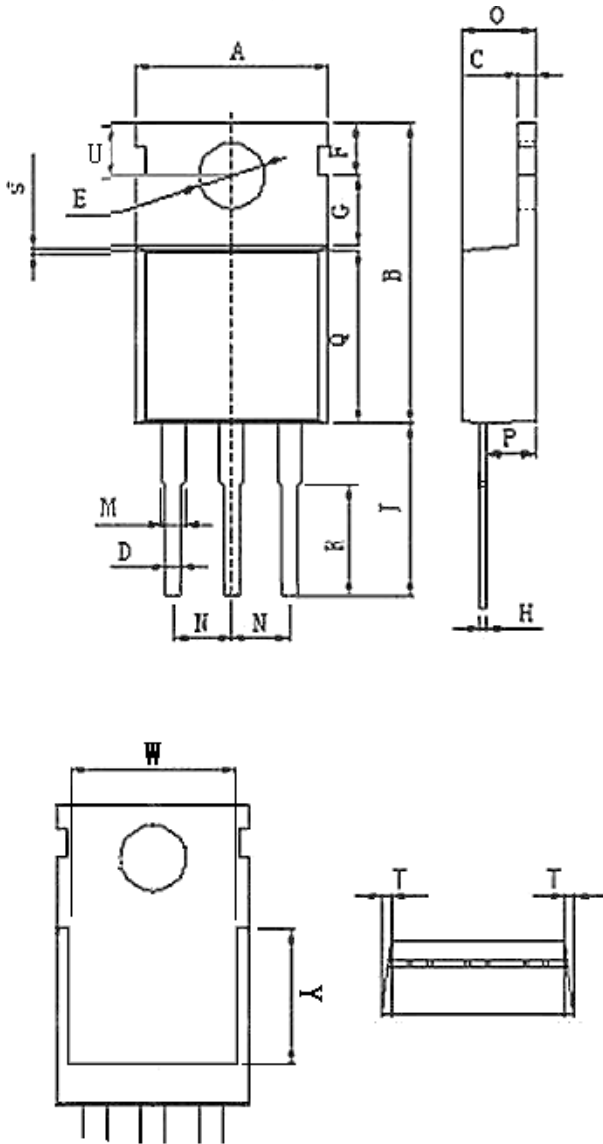

DIM	MILLIMETERS
A	10.1±0.2
B	15.6±0.2
C	1.2±0.2
D	0.8±0.2
E	3.7±0.2
F	3.0±0.2
G	3.6±0.2
H	0.5±0.2
J	6.5±0.1
K	3.5±0.1
M	1.3±0.2
N	2.6±0.2
O	4.5±0.2
P	2.0±0.2
Q	9.0±0.2
S	0.25±0.1
T	0.25±0.1
U	2.8±0.07
W	8.0±0.2
Y	6.4±0.2

(单位: mm)