

LOW FREQUENCY, LOW NOISE AMPLIFIER

- Collector-Emitter Voltage: $V_{CE0} = -45V$
- Collector Dissipation: $P_C = 200mW$

Absolute Maximum Ratings (TA=25°C)

Characteristic	Symbol	Rating	Unit
Collector-Base Voltage	V_{CBO}	-50	V
Collector-Emitter Voltage	V_{CEO}	-45	V
Emitter-Base Voltage	V_{EBO}	-5	V
Collector Current	I_C	-100	mA
Collector Dissipation	P_C	200	mW
Junction Temperature	T_J	150	°C
Storage Temperature	T_{STG}	-55~+150	°C

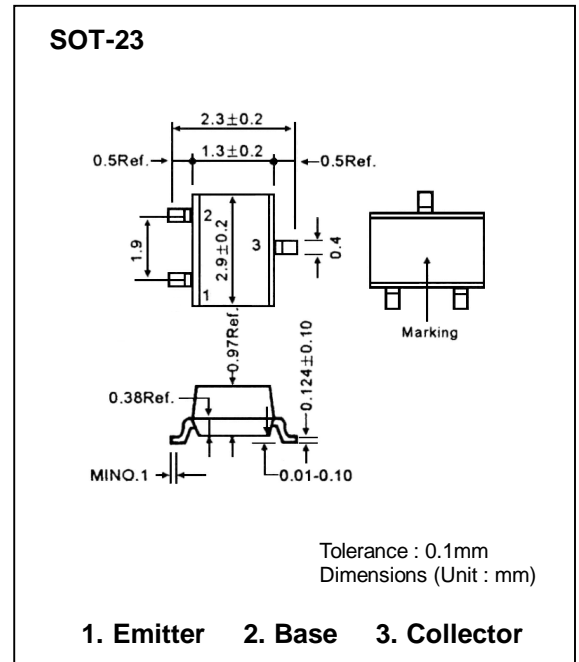

Electrical Characteristics (TA=25°C)

Characteristic	Symbol	Test Conditions	Min	Max	Unit
Collector-Base Breakdown Voltage	BV_{CBO}	$I_C = -100\mu A, I_E = 0$	-50		V
Collector-Emitter Breakdown Voltage	BV_{CEO}	$I_C = -1mA, I_B = 0$	-45		V
Emitter-Base Breakdown Voltage	BV_{EBO}	$I_E = -100\mu A, I_C = 0$	-5	-0.05	V
Collector Cut-off Current	I_{CBO}	$V_{CB} = -50V, I_E = 0$		-0.05	μA
Emitter Cut-off Current	I_{EBO}	$V_{EB} = -5V, I_C = 0$		1000	μA
DC Current Gain	h_{FE}	$V_{CE} = -5V, I_C = -1mA$	200	-0.3	
Collector-Emitter Saturation Voltage	$V_{CE(sat)}$	$I_C = -100mA, I_B = -10mA$		-1	V
Base-Emitter Saturation Voltage	$V_{BE(sat)}$	$I_C = -100mA, I_B = -10mA$			V
Transition Frequency	f_T	$V_{CE} = -5V, I_C = -10mA$ $f = 30MHz$	150		MHz

h_{FE} CLASSIFICATION

Classification	L	H
h_{FE}	200– 450	450 – 1000

Device Marking

S9015LT1=M6